

Save This Manual
For Future Reference

SEARS

Operators Manual

**MODEL NO.
113.197410**

10" DELUXE ELECTRONIC
RADIAL SAW WITH
44" CABINET AND
2 DOORS

or

113.197610

10" DELUXE ELECTRONIC
RADIAL SAW WITH
44" CABINET AND
6 DRAWERS

Serial
Number _____

Model and serial numbers
may be found at the rear of
the base.

You should record both
model and serial number in
a safe place for future use.

CAUTION:

**READ ALL
INSTRUCTIONS
CAREFULLY**

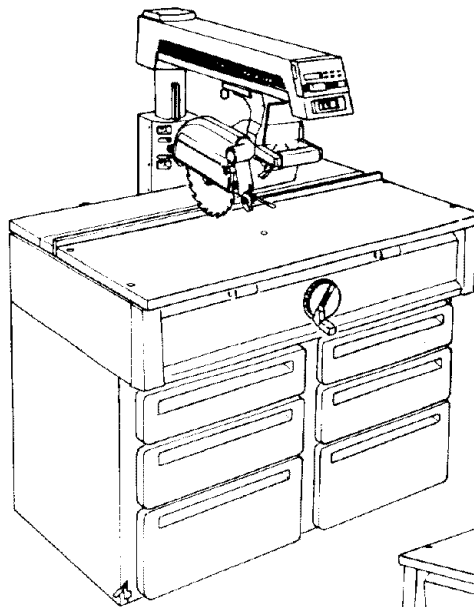

MODEL 113.197610

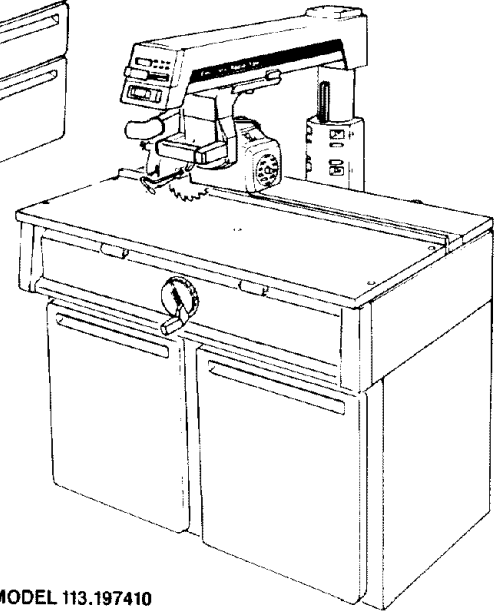

MODEL 113.197410

CRAFTSMAN

10-INCH DELUXE ELECTRONIC RADIAL SAW

- Assembly
- Operating
- Repair parts

Sold by SEARS, ROEBUCK AND CO., Chicago, IL. 60684 U.S.A.

FULL ONE YEAR WARRANTY ON CRAFTSMAN RADIAL SAW

If within one year from the date of purchase, this Craftsman Radial Saw fails due to a defect in material or workmanship, Sears will repair it, free of charge.

WARRANTY SERVICE IS AVAILABLE BY SIMPLY CONTACTING THE NEAREST SEARS SERVICE CENTER/DEPARTMENT THROUGHOUT THE UNITED STATES.

This warranty applies only while this product is used in the United States.

This warranty gives you specific legal rights and you may also have other rights which vary from state to state.

SEARS, ROEBUCK AND CO., DEPT. 698/731A Sears Tower, Chicago, IL 60684

Table of Contents

SectionTitle	Page Numbers
Safety Information	3-6
Putting Your Saw Together	7-30
Location and Function of Controls	31-34
Alignment of the Blade	35-49
Digital Display	50-55
Electrical Connections	56-67
Crosscutting	58-64
Ripping	65-73
Cutting Accessories	74-77
Recommended Accessories	78
Lower Blade Guard Safety Information	79
Glossary	80
Helpful Hints	81-82
Maintaining Your Saw	83-89
Changing Motor Voltage	90
Trouble Shooting	91-96
Parts Lists	98-116

Safety Information

The operator's manual contains safety information, instructions and signs for your protection against serious injuries, including:

Loss of fingers, hand, arm or leg from contact with the saw blade.

Eye injuries, including being blinded from being hit by a thrown workpiece, workpiece chips or pieces of the saw blade.

Impact injuries, including broken bones and internal organ damage, from being hit by a thrown workpiece, workpiece chips or pieces of the saw blade.

Shock, electrocution, or burn injuries from contact with wires, motor or other saw parts.

Safety Symbol and Signal Words

The safety information in this manual is highlighted by the following safety alert symbol.



Fig. 1 Safety Alert Symbol

The following signal words are used to indicate the level of risk.

⚠ DANGER: Means that if the safety information is not followed, someone **will** be seriously injured or killed.

⚠ WARNING: Means that if the safety information is not followed someone **could** be seriously injured or killed.

⚠ CAUTION: Means that if the safety information is not followed someone **may** be injured.

All of the safety information and cutting steps are critical to the safe operation of the radial arm saw.

Major Hazards

1. Workpiece Kickback

Kickback is an uncontrolled grabbing and throwing of the workpiece during ripping. If kickback occurs, the workpiece can hit you hard enough to cause broken bones, internal organ injury or death. To reduce or prevent kickback, read and follow the safety information in the Ripping section of the manual.

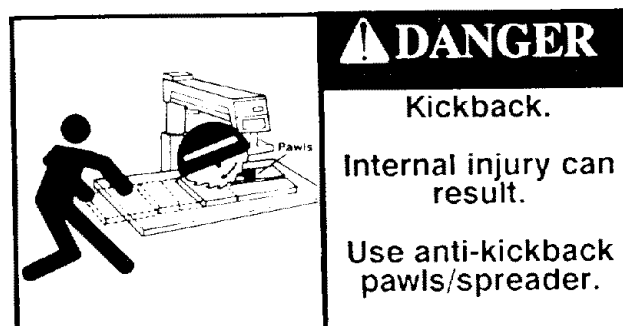

Fig. 2 Kickback Safety Sign

2. Kickback Followed by Blade Contact

Kickback followed by blade contact can happen when the saw blade is pinched or bound by the workpiece during ripping. Kickback can happen if you reach around the blade to the end **with** the anti-kickback pawls, (out-feed end), and try to hold-down or pull the workpiece through to complete the cut. Your fingers, hand, or arm can be cut off by the blade if the workpiece kicks back.



Fig. 3 Blade Contact Safety Sign

3. Wrong Way Feed

Wrong way feed is feeding the workpiece into the end of the saw **with** the anti-kickback pawls. The workpiece can be grabbed by the blade and pull your hands into the blade before you can let go or pull back. Fingers, hand or arm can be cut off.

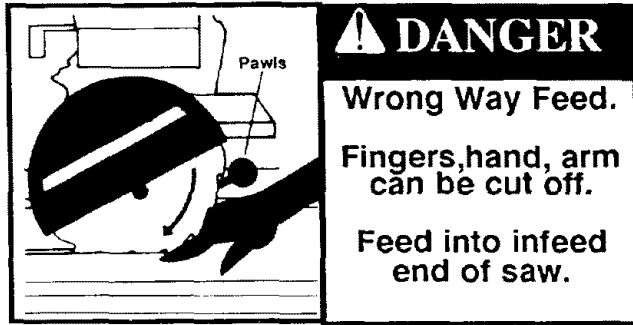

Fig. 4 Wrong Way Feed Safety Sign

If a workpiece is fed into the end of the saw **with** the anti-kickback pawls, it can take off like a missile. Anyone hit by the workpiece can be killed. Feed the workpiece into the infeed end of the saw blade, the end that does **not** have the anti-kickback pawls.

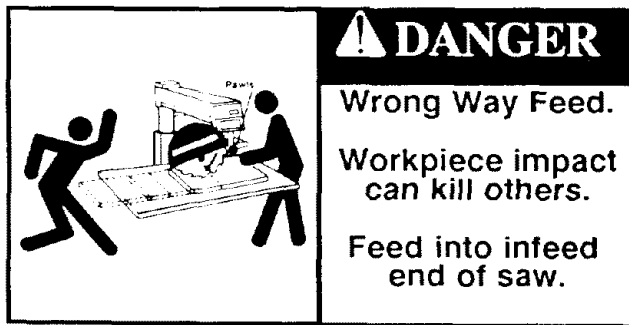

Fig. 5 Wrong Way Feed Safety Sign

4. Thrown Workpiece Chips and Blade Pieces

The saw can throw the workpiece, workpiece chips or pieces of the blade violently. You can be blinded. Wear safety goggles labeled "ANSI Z87.1" on the package.



Fig. 6 Safety Goggles Safety Sign

! DANGER: Follow the 8 steps listed below to reduce or eliminate the risk of being injured when using the radial arm saw. Failure to do so can result in a life threatening injury or death.

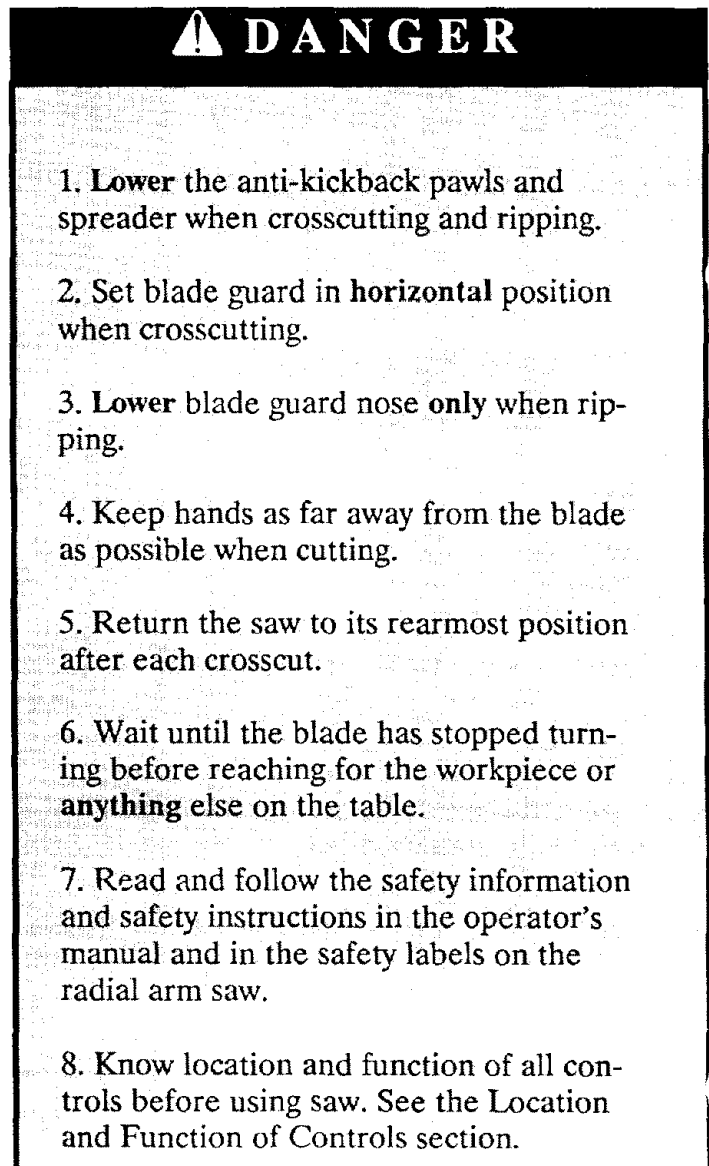

Personal Safety

1. Wear safety goggles labeled "ANSI Z87.1" on the package. Do not wear regular glasses, they are not safety glasses.
2. Wear snug fitting clothes, short sleeve shirts and nonslip footwear. Cover up or tie long hair. Do not wear loose, baggy clothes, gloves, neckties, rings, watches or any other jewelry.
3. Wear a dust mask, with your safety goggles, if cutting operation is dusty.
4. Wear hearing protectors, ear plugs or muffs, if you use the saw daily.
5. Keep good footing and balance. Don't over-reach.

Work Area Safety

1. Keep children, pets and visitors out of the work area.
2. Make the work area child proof. Remove the yellow key from the red switch and place it out of reach and sight. Lock work area.
3. Keep floors dry and free from sawdust, wax or other slippery materials.
4. Keep work area clean, uncluttered and well lighted.
5. Use the saw in a dry area. Do not use in wet or damp area. Do not use outside.
6. Clear the table of all objects (adjusting wrenches, tools, scraps of wood etc.) except the workpiece to be cut, fixtures or clamps before turning the saw on.
7. Do not do layout, assembly or setup work on the table while the blade is turning.
8. Store items away from the saw. Do not climb on the saw to reach items. Do not stand on the table; the saw can tip over.

Saw Safety

1. Keep guards and anti-kickback pawls in place and in working order.
2. Check for broken or damaged parts before using saw. A damaged guard or other saw part should be checked for alignment, binding, breakage and correct mounting to make sure they are working properly. Repair or replace damaged guards or other saw parts.
3. Unplug saw before doing maintenance, making adjustments, and changing blades and accessories.
4. Use clamps or vice to hold workpiece when practical. It's safer than using your hands and frees them to operate the saw.
5. Do not force the saw, saw blade or accessories to do jobs they are not designed to do.
6. Make sure the yellow key is removed and the red switch is in the off position before plugging in the power cord.
7. Cut only wood, woodlike or plastic materials. Do not cut metal materials.
8. Secure the saw to floor, wall, bench or table if it slides, tips or walks during use.
9. Feed the workpiece against the direction of rotation of the blade when ripping.
10. Turn the saw off before leaving work area. Do not leave the saw until the blade has stopped.
11. Lock the rip and miter locks before moving the saw from one location to another.
12. Turn the saw off and remove yellow key if the blade jams. Do not try to free a jammed workpiece with the saw on.
13. Turn the saw off if it vibrates excessively or makes an unfamiliar noise. Correct any problems before restarting saw.

14. Rip workpieces that are longer than the diameter of the blade being used. Do not rip a workpiece that is shorter than the diameter of the blade being used.

15. Cut only one workpiece at a time. Do not cut stacked workpieces or lay them edge to edge for cutting.

Workpiece Support Safety

1. Use additional supports for workpieces which extend beyond the saw table. Large workpieces can shift, twist, rise from table or fall after they are cut.

2. Helpers can be hit by a thrown workpiece, workpiece chips or pieces of the blade. Use table extensions or other supports. Do not use helpers.

3. Helpers can cause the workpiece to kick-back. Do not use other people to support or assist in feeding or pulling the workpiece. Use table extensions.

4. When table extensions over 24 inches wide are added to either side of the saw, make sure you either bolt the saw to the floor or support the outer end of the extension from the floor with sturdy legs or an outrigger.

5. **Use Only Recommended Accessories.** Follow the instructions that come with the accessories. Consult the owner's manual for recommended accessories. The use of improper accessories may cause risk of injury to persons.

Blade Safety

1. Use blades marked for 3450 rpm or higher.
2. Do not use blades larger than 10 inches in diameter.
3. Keep blade sharp and clean.
4. Do not cycle motor switch on and off rapidly; the blade can loosen.
5. Do not overtighten the blade; the blade collar can be warped.

Safety Labels on the Radial Arm Saw

The following labels are on your radial arm saw. Locate, read and follow the safety instructions and information contained in these labels.

1. Wrong way feed label located on the out-feed end of the blade guard.

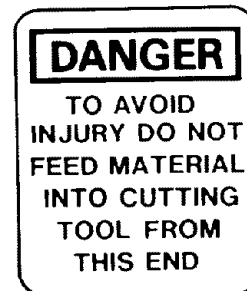

Fig. 7 Wrong Way Feed Label

2. Safety instruction label located on the front of the saw near the handwheel.

DANGER

FOR YOUR OWN SAFETY:

1. Read and understand owner's manual before operating machine.
2. Wear safety goggles complying with ANSI Z87.1.
3. Keep hands out of path of saw blade.
4. Never reach around the saw blade.
5. Never perform any operation "FREEHAND."
6. Return carriage to the full rear position after each cross-cut type operation.
7. Shut off power and allow saw blade to stop before adjusting or servicing.

Fig. 8 Safety Instruction Label

3. Ripping safety label located on the motor.



Fig. 9 - Ripping Safety Label

Putting Your Saw Together

Your radial arm saw is easy to put together, however it will take time. Ask a friend to help, and follow these assembly instructions. It is important for your safety, and for the quality of your cuts, that the saw be put together with care.

This manual was written for two different models of the radial arm saw: model 113.197610 has drawers for the cabinet, and model 113.197410 has doors.

The following assembly sections should be followed for both models:

- Unpacking / Set up
- Information
- Attaching Handwheel
- Mounting Motor
- Mounting Saw
- Attaching Trim Ledge and Trim Caps
- Mounting Table Locks
- Mounting the Front Table

All other sections are labelled with the correct model number. Follow **ONLY** instructions that are meant for your model saw. Both models work in the same way once they are put together.

⚠ WARNING: Plugging the saw in during assembly can result in electrical shock or your fingers, hand, or arm being cut off from blade contact. Do not plug in the saw at any time during assembly. The saw should only be plugged in when it is to be used.

Unpacking/Set up

Both Models

1. Some parts of your radial arm saw are packaged in small boxes according to function. As you unpack, try to keep the contents

of each of the smaller boxes together and separate from the others. This will help you identify and locate the parts you need during assembly.

The following parts are included with model 113.197610:

A.	Basic Saw Assembly	1
B.	Operator's Manual	1
C.	Cabinet Box	1
D.	Drawer Box	1
E.	Caster/Foot Box	1
F.	Loose Parts Bags	*8
G.	Trim Caps	2
H.	Rear Table	1
I.	Spacer	1
J.	Fence	1
K.	Front Table	1

*This is the total number of loose parts bags. Two of these are packed inside the Caster/Foot Box, and four are packed inside a larger loose parts bag.

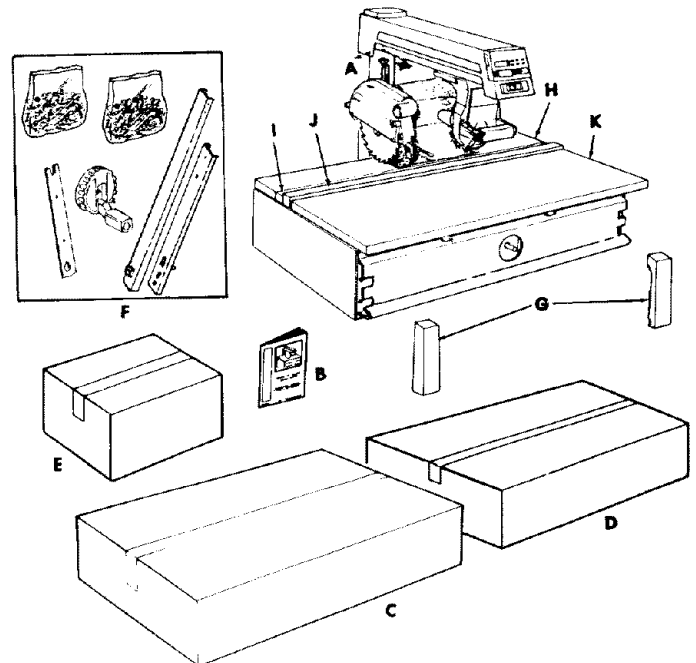

Fig. 10 - Parts for Model 113.197610

The following parts are included with model 113.197410:

- A. Basic Saw Assembly 1
- B. Operator's Manual 1
- C. Cabinet Box 1
- D. Loose Parts Bags *7
- E. Trim Caps 2
- F. Rear Table 1
- G. Spacer 1
- H. Fence 1
- I. Front Table 1

*Note: This is the total number of loose parts bags. One of these is packed inside the Cabinet Box, and four are packed inside a larger loose parts bag.

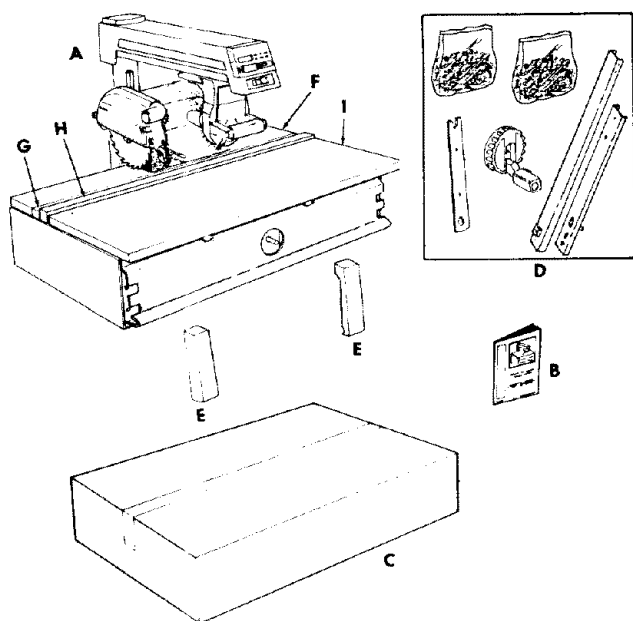

Fig. 11 - Parts for Model 113.197410

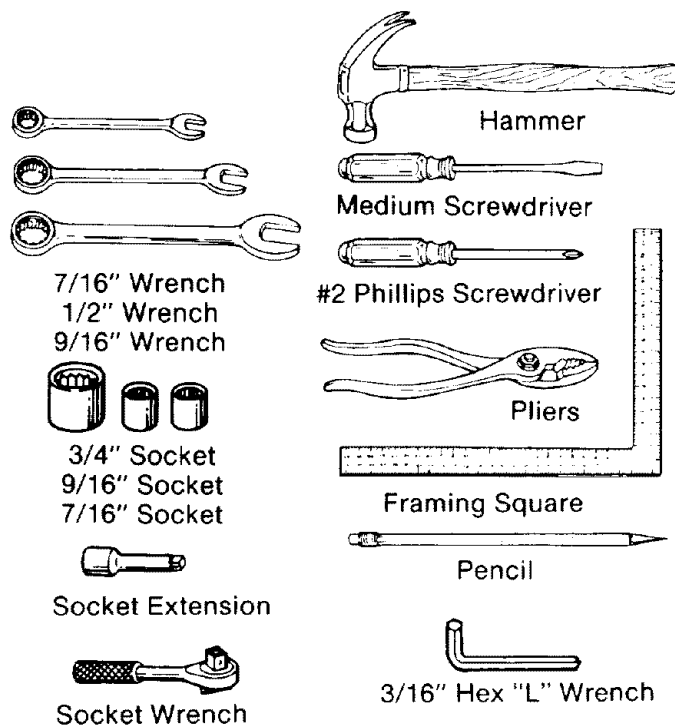

Fig. 12 - Tools Required

4. Open the loose parts bags, and sort the contents into piles on the floor or table. This will make it easier for you to find the part(s) you need during assembly.

The following loose parts are included with model 113.197610:

- A. Drawer Fasteners48
- B. Truss Head Bolts 1/4-20x1/2 78
- C. Hex Nuts 1/4-20 78
- D. Lockwashers 1/4 78
- E. Rods 2
- F. Levers 2
- G. Washers 2
- H. Springs 2
- I. Smooth Pins 2
- J. Grooved Pins 2
- K. Retaining Plates 2
- L. Actuator Boxes 2
- M. Phillips Head Screws 10-32x3/8 4

2. Identify the large parts of your saw before beginning each section. Your task will be easier if you are familiar with these parts.

3. Identify the tools required for assembly. Make sure that you have all of the tools you will need. (Figure 12)

N.	Slotted Screws 1/4-20x7/16	4
O.	Truss Head Bolts 1/4-20x1/2	16
P.	Hex Nuts 1/4-20	18
Q.	Lockwashers 1/4	18
R.	Spacers	2
S.	Truss Head Bolts 1/4-20x1	2
T.	Leveling Feet	2
U.	Hex Nuts 3/8-16	2

The following loose parts are included with model 113.197410:

A.	Leveling Feet	4
B.	Hex Nuts 3/8-16	8
C.	Truss Head Bolts 1/4-20x1/2	62
D.	Lockwashers 1/4	62
E.	Hex Nuts 1/4-20	62
F.	Pan Head Screws 6	4
G.	Pan Head Screws 6-32x3/8	4
H.	Plastite Screws 10	8
I.	Magnetic Catches	2
J.	Hinges	4

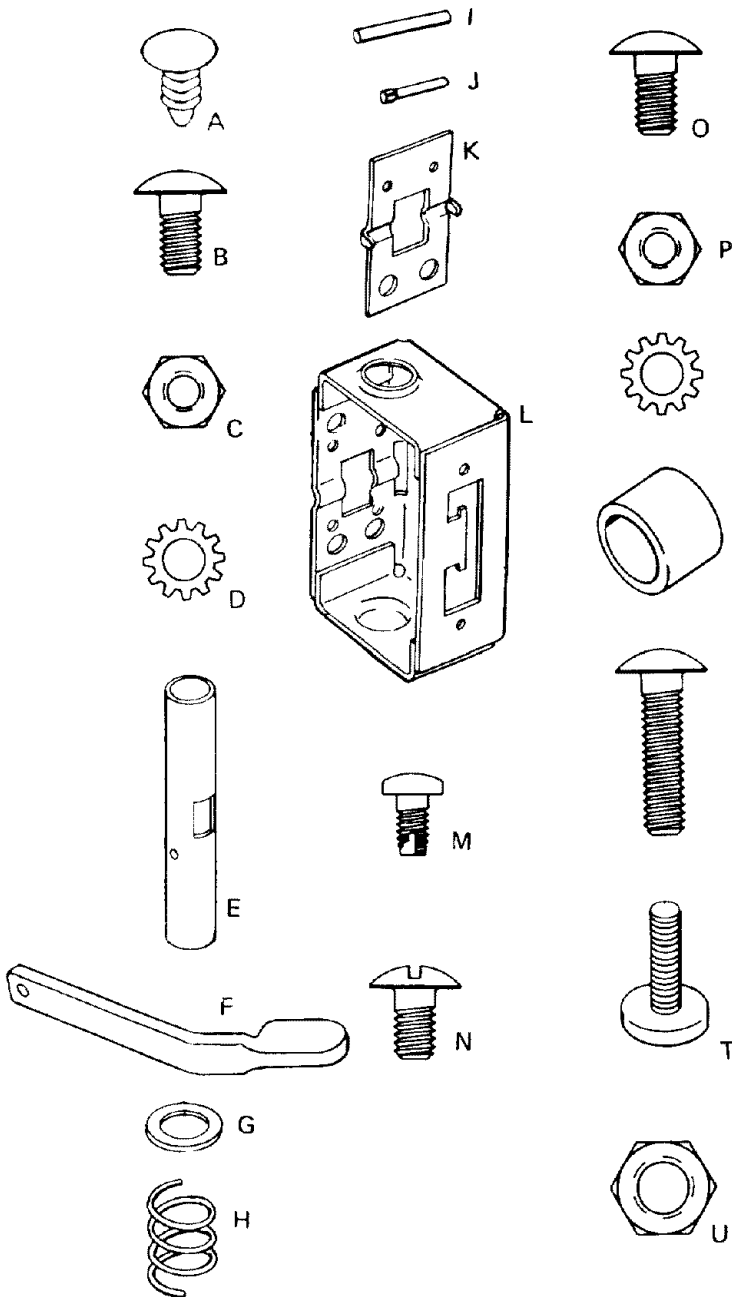

Fig. 13 - Loose Parts, Model 113.197610

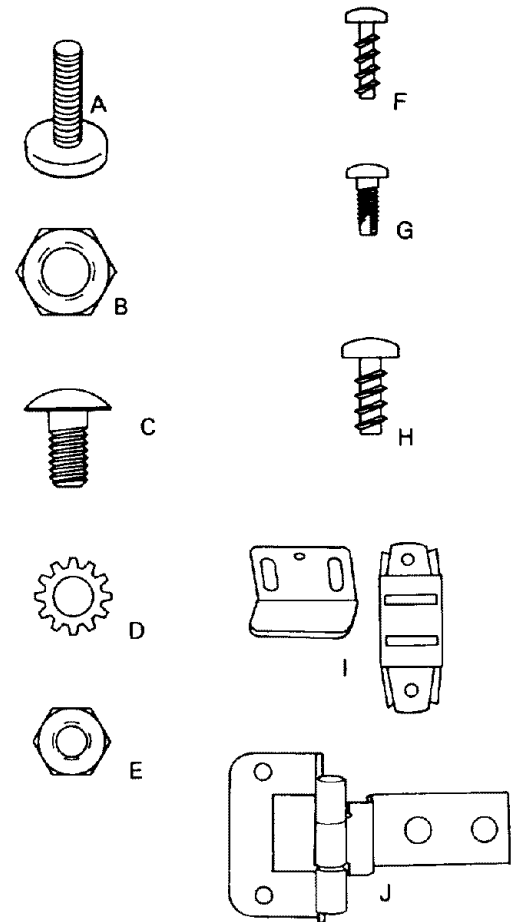

Fig. 14 - Loose Parts, Model 113.197410

The following loose parts are included with both models:

A.	Handwheel	1
B.	Arbor Wrenches	2
C.	Yoke Plug	1
D.	Yellow On/Off Key	1
E.	Battery 6V, alkaline, size J	1
F.	Pan Head Screw 10-32x1/2	1
G.	Lockwasher 10	1
H.	Battery Cover	1
I.	Screw Pan Head 1/4-20x1-1/8	6
J.	Locknuts 1/4-20	2
K.	Washers 17/64x9/16x3/64	8
L.	Hex Head Bolts 1/4-20x5/8	4
M.	Lockwashers 1/4	8
N.	Hex Nuts 1/4-20	8
O.	Screw Truss Head 1/4-20x1/2	2
P.	Mounting Screws 1/4-20x1-3/4	5
Q.	Washers 17/64x5/8x1/32	5
R.	Rubber Grommets	5
S.	U-Clips 1/4-20	5
T.	Tee Nuts	3
U.	Leveling Screws 1/4-20x7/8	3
V.	Pan Head Screws 1/4x5/8	4
W.	Washers 17/64x3/4x1/16	4
X.	Right Slide Arm	1
Y.	Left Slide Arm	1
Z.	Lock Handles	2
AA.	Spacer	2
BB.	Table Support Channels	2
CC.	Actuator Channels	2
DD.	Bushing	1

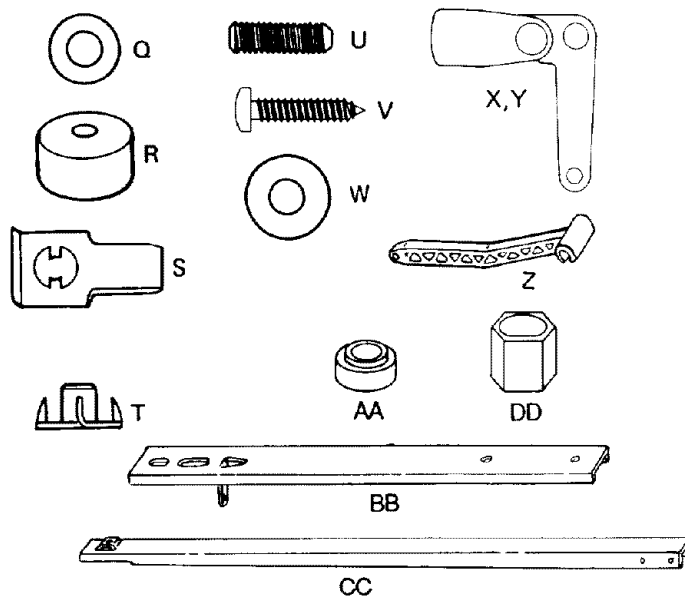

Fig. 15 - Loose Parts, Both Models

Information

Both Models

1. If you are missing any part while putting your saw together, do not continue assembly. Contact your Sears Service Center or Retail Store and get the missing part before continuing assembly or trying to use the saw.

Complete parts lists are located at the end of this manual. Use these lists to identify the number of any missing part.

2. Sometimes small parts get lost in packaging materials. Do not throw away any packaging until your saw is put together. If you are missing a part, check the packaging before contacting Sears.

3. Most parts of your radial arm saw will be fastened together using truss head bolts, lockwashers, and hex nuts of the sizes shown. (Figure 16) When different sizes are needed, the instructions will include a sketch to help you locate the correct size.

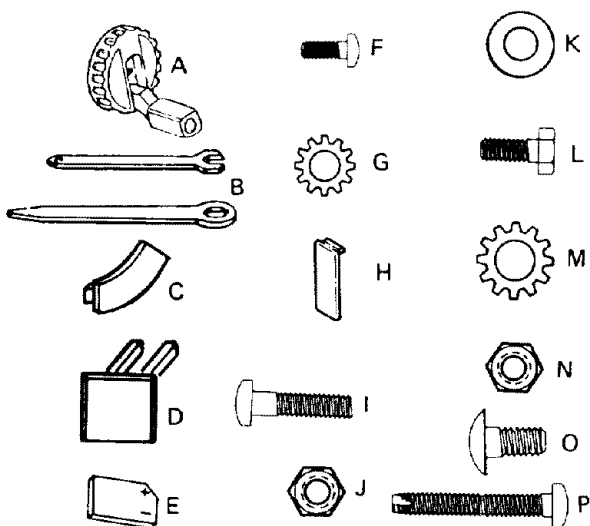

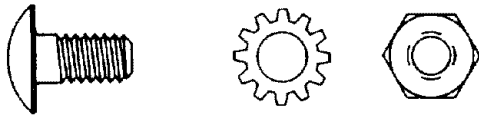

Fig. 16 - Truss Head Bolt, Lockwasher, Hex Nut

4. As you assemble your radial arm saw, some of the holes in the parts will line up and others will not. This happens because some parts are used in other equipment or for other purposes. Follow the instructions carefully. The figures will show which holes should line up in each step.

Model 113.197610

Beginning the Cabinet

The following parts are used in the cabinet assembly for model 113.197610:

A.	Right Side Panel	1
B.	Left Side Panel	1
C.	Shelf	1
D.	Under Support	1
E.	Skirts	2
F.	Front Shelf Stiffener	1
G.	Corner Brackets	4
H.	Lower Support	1
I.	Rear Supports	3
J.	Upper Support	1
K.	Front Support	1
L.	Rear Shelf Stiffener	1

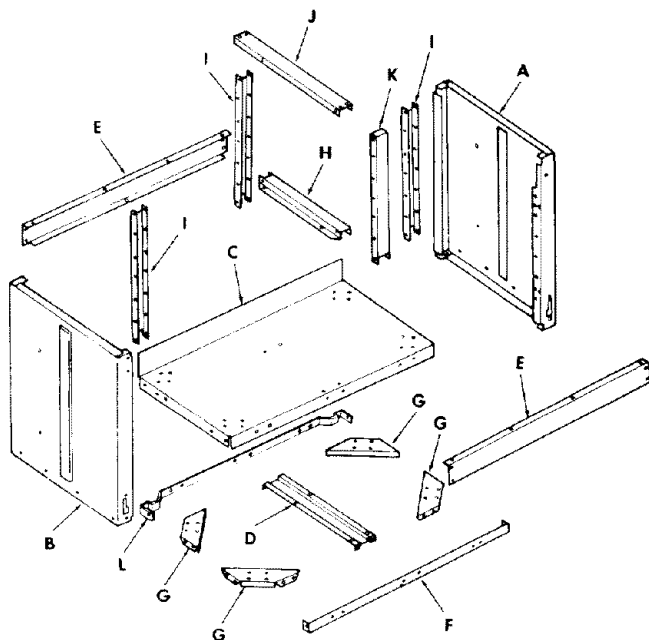

Fig. 17 - Cabinet Assembly - 113.197610

1. Turn the *shelf* upside down on the floor. The wide edge should point down, and the three narrow edges should point up. (Figure 18)

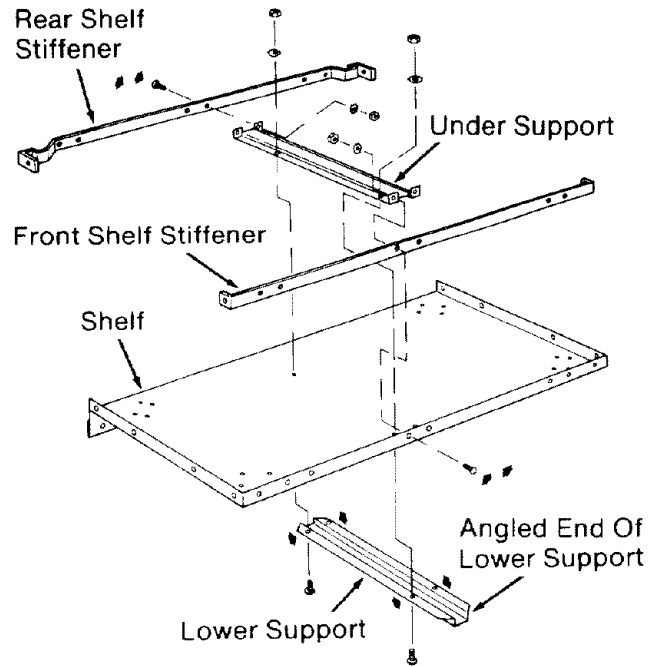

Fig. 18

2. Place the *front shelf stiffener* inside and against the front edge of the *shelf* so that all six holes line up. (Figure 18)

3. Place the *under support* on the *shelf*, so that the two holes on one end line up with the center holes on the other two parts. (Figure 18)

4. Place the *lower support* under the shelf. It should rest directly below the *under support*, with the angled end sticking out. Line up the four holes in these three pieces. (Figure 18)

Note: The angled end of the *lower support* is a useful way to tell the front of the cabinet from the back. The **angled end** is at the **front** of the cabinet.

5. Place the *rear shelf stiffener* on the *shelf* so that the two ends fit between the edges of the *shelf*, and the two center holes line up with the holes at the end of the *under support*. (Figure 18)

6. Put truss head bolts through the eight holes indicated. Put a lockwasher and hex nut on each bolt tighten using a 7/16 inch wrench or socket.

7. Put a *corner bracket* in each corner of the *shelf*. (Figure 19)

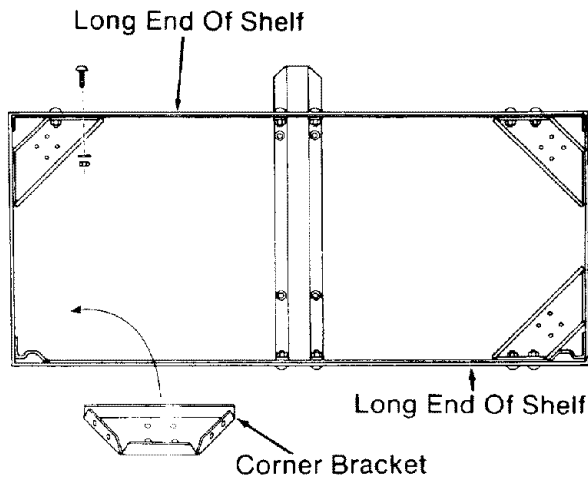

Fig. 19

8. Put two truss head bolts through the *shelf* and each *corner bracket* to hold the brackets in place. Only put bolts through holes in the long edges of the *shelf*, not the narrow ends, as shown. (Figure 19)

9. Put a lockwasher and hex nut on each bolt and hand-tighten.

Attaching Casters / Building Foot Assemblies

The following parts are used in the caster and foot assemblies for model 113.197610:

A.	Casters	4
B.	Actuator Boxes	2
C.	Levers	2
D.	Rods	2
E.	Retaining Plates	2
F.	Grooved Pins	2
G.	Smooth Pins	2
H.	Washers	2
I.	Springs	2
J.	Hex Nuts 3/8-16	2
K.	Leveling Feet	2
L.	Phillips Head Screws 10-32x3/8	4

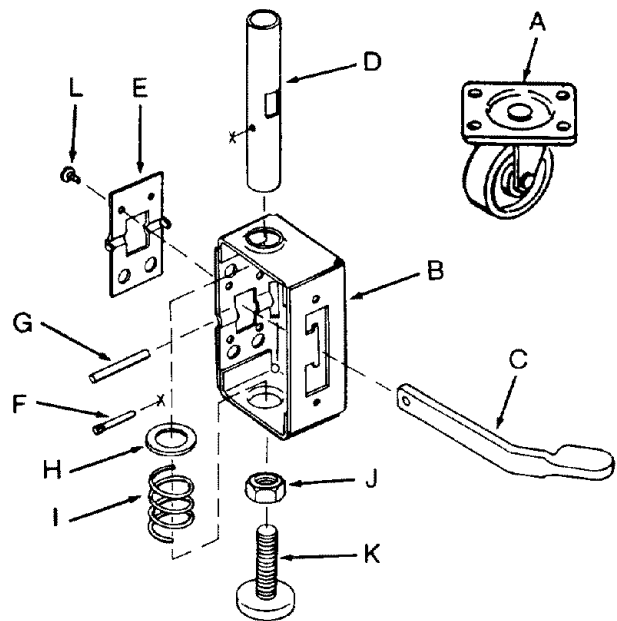

Fig. 20 - Parts for Caster / Foot Assemblies

1. Put the *casters (wheels)* on the *shelf* and *corner brackets*. Since the *shelf* is upside down, the *wheels* will point up. Line up four holes in each corner. (Figure 21)

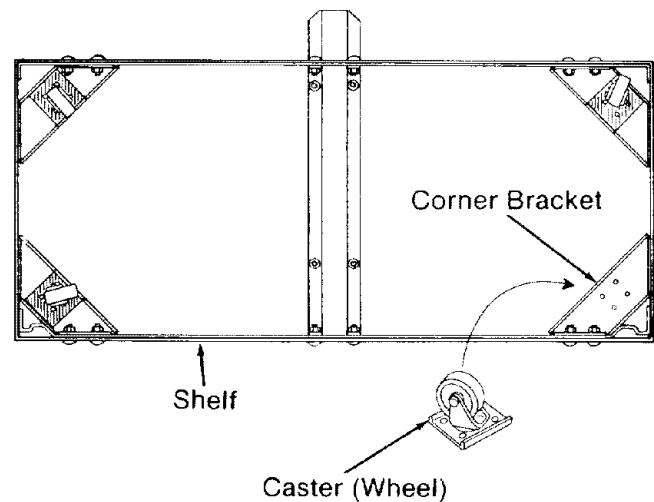

Fig. 21

2. Put bolts through the four holes in each corner. Put a lockwasher and hex nut on each bolt and tighten using a 7/16 inch wrench or socket.

3. Separate all of the parts for the *foot assemblies* into two groups. There are two sets

of identical parts. These will be put together into *left* and *right foot assemblies* which are mirror images of each other. (Figure 22)

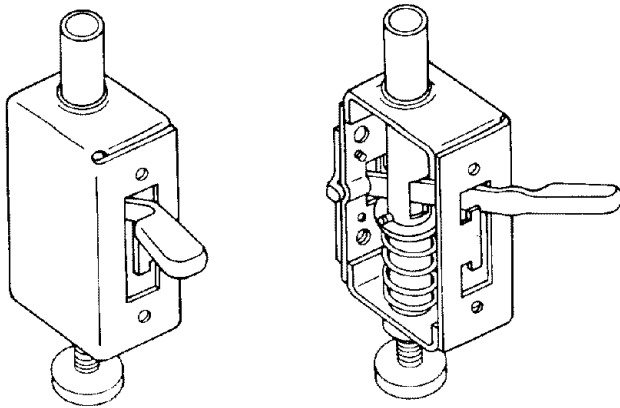

Fig. 22 - Left and Right Foot Assemblies

4. Place an *actuator box* in front of you with the C-shaped slot facing you and the closed surface of the *box* to the left. This will become the *left foot assembly*. (Figure 23)

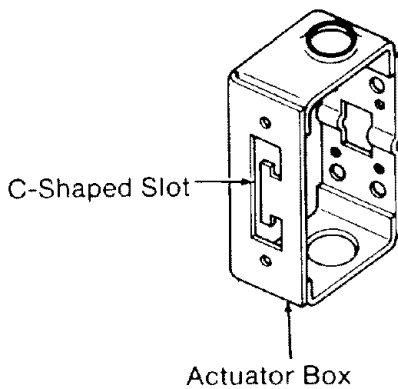

Fig. 23

5. Slide a *rod* halfway down into the *actuator box*. Make sure that the threaded end of the *rod* is down, and that the smaller square opening in the *rod* is facing you.

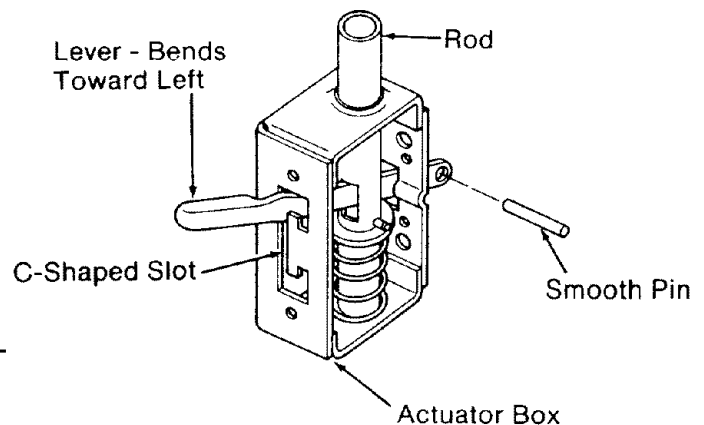

Fig. 25 - Building Left Foot Assembly

6. Put a *grooved pin* through the hole in the *rod*.

7. Put a *washer* and *spring* in place on the bottom of the *rod*, and then slide the *rod* all the way down. (Figure 24)

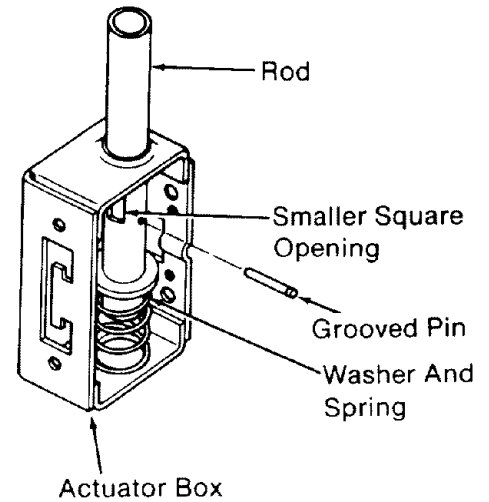

Fig. 24 - Building Left Foot Assembly

8. Slide a *lever* through the C-shaped slot in the *actuator box*, through the square hole in the *rod*, and through the square opening in the back of the *actuator box*. Make sure that the *lever* bends toward the left. (Figure 25)

9. Apply a few drops of *oil* (SAE No. 10W-30 automotive engine oil) to the *lever* where it passes through the square hole in the *rod*.

10. Put a *smooth pin* through the hole in back of the *lever*. (Figure 25)

11. Pull the *lever* forward so that the *smooth pin* is in the groove on the *actuator box*.

12. Place a *retaining plate* over the *smooth pin* with the smaller two holes on top.

13. Place two Phillips head screws in the top two holes and tighten using a Phillips screwdriver. (Figures 26 & 27)

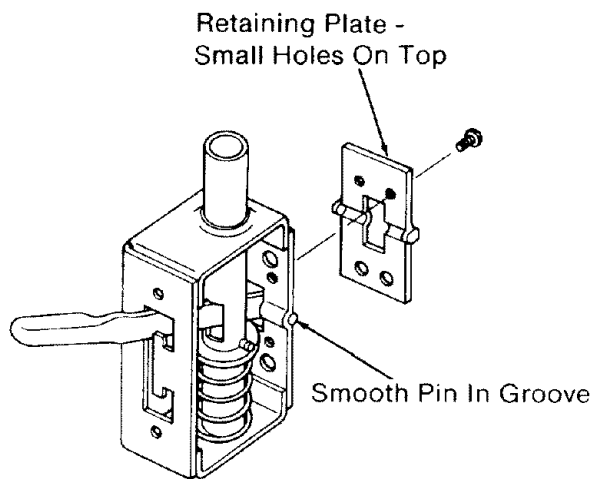

Fig. 26

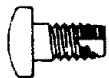

Fig. 27 - Phillips Head Screw

14. Put a hex nut on one of the *leveling feet* and hand-tighten. (Figure 28)



Fig. 28 - Hex Nut for Leveling Foot

15. Screw the *leveling foot* into the *rod* until the hex nut reaches the bottom of the *rod*. (Figure 29)

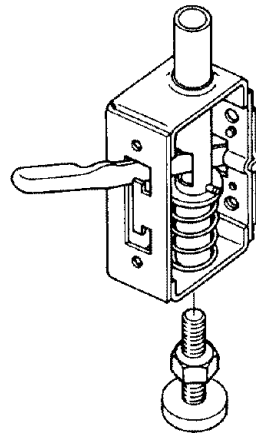

Fig. 29 - Left Foot Assembly

16. Place the second *actuator box* in front of you with the C-shaped slot facing you and the closed surface of the *box* to the right. This will become the *right foot assembly*.

17. Repeat steps 5-15 to put together the *right foot assembly*. The *lever* should bend toward the right in the *right foot assembly* (see step 8).

Attaching Foot Assemblies

1. Find the *right* and *left side panels*. Look carefully to find the "R" and "L" stamped in the metal near the center of the rear edges (opposite the J-shaped slots). These stamps are the easiest way to tell the *right panel* from the *left*. (Figure 30)

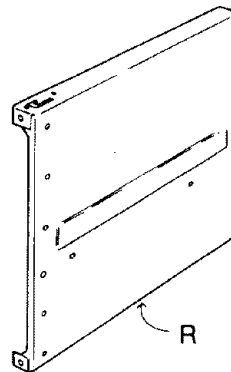

Fig. 30

2. Lock the *lever* on the *right foot assembly* in the down position.

3. Attach this *foot assembly* to the *right side panel* by sticking the *lever* through the J-shaped slot in the *side panel*, and screwing in two slotted screws.
(Figures 31 & 32)

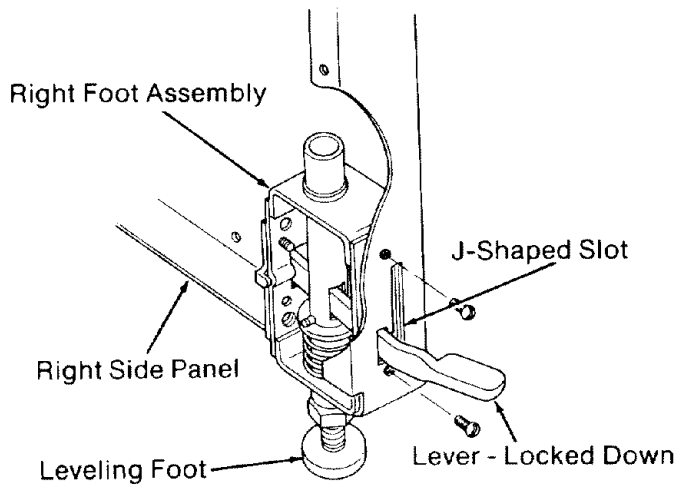

Fig. 31.

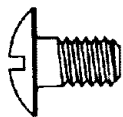

Fig. 32 - Slotted Screws

4. Repeat steps 2-3 with the *left foot assembly*, *left side panel* and *left lever*.

Finishing the Cabinet

1. Find the twelve *outer brackets* and twelve *center slides* that will be put together to form the *slide brackets*. (Figure 33)

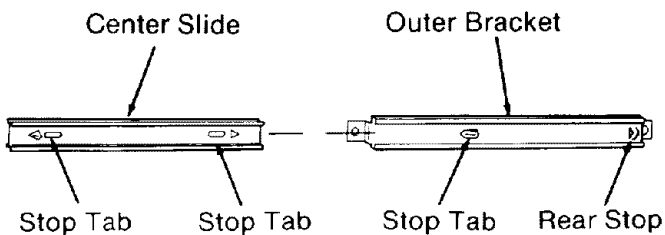

Fig. 33

2. Grease the twelve *center slides* on top and bottom using the *grease packets* included with your saw.

3. Slide each *center slide* into an *outer bracket*. There are two notches on each *center slide* that stick out on opposite sides. Make sure that you insert the notch sticking out toward the *outer bracket* first. This notch should stop the *center slide* from sliding off the *outer bracket*. (Figure 33)

4. Hold a *rear support* with the long tabs down, short tabs up, and the solid surface facing you.

5. Attach three *slide brackets* to the left side of this *rear support* with three truss head bolts. Make sure that you attach the larger hole in the *slide bracket* to the *rear support*. Put a lockwasher and hex nut on each bolt and tighten using a 7/16 inch wrench or socket. (Figure 34)

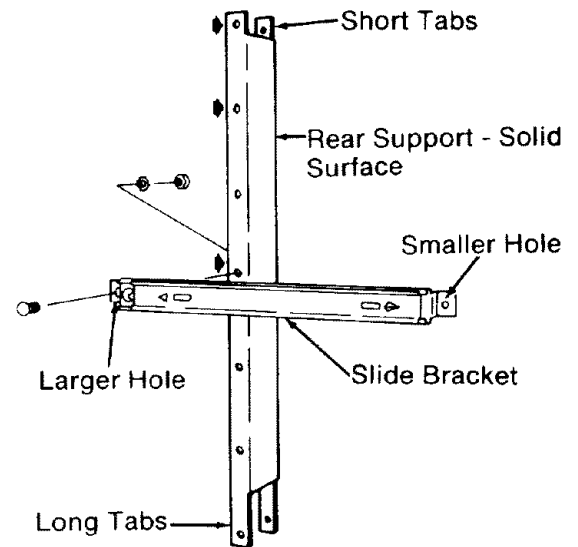

Fig. 34

6. Attach this *rear support* to the *right side panel* with two truss head bolts. Make sure that the long tabs are on the bottom and the short tabs are on top. Make sure that the solid surface is facing front. Put a lockwasher and hex nut on each bolt and tighten using a 7/16 inch wrench or socket. (Figure 35)

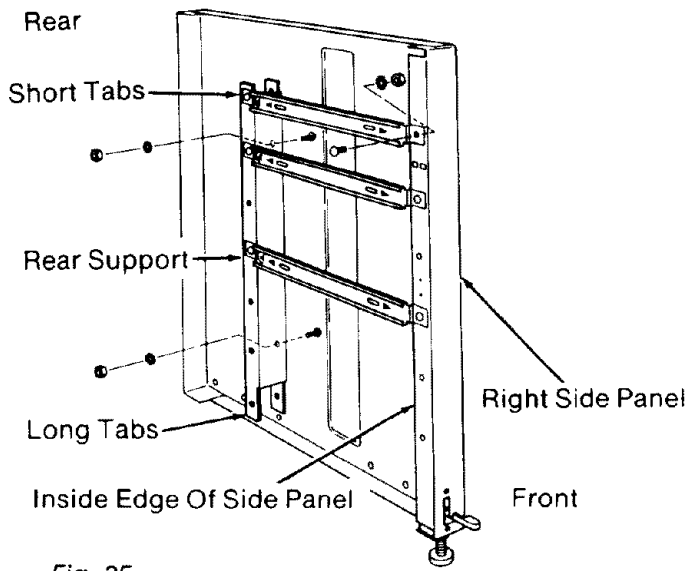

Fig. 35

7. Repeat steps 4 - 6 with another *rear support* and the *left side panel*. Attach the *slide brackets* to the right side of this *rear support*

8. Attach the front end of each *slide bracket* to a hole on the inside edge of the *side panels* with six truss head bolts. Put a lockwasher and hex nut on each bolt and tighten with a 7/16 inch wrench or socket. (Figure 35)

9. Lay the *shelf* on the rear edge with the bottom side toward you. The angled end of the *lower support* should point up.

10. Place the *right side panel* on the right side of the *shelf*. The *slide brackets* should be on the inside of the cabinet. (Figure 36)

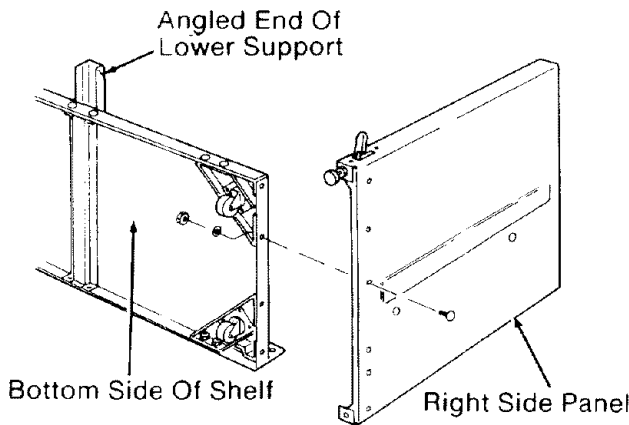

Fig. 36

11. Put bolts through the four holes along the bottom edge of the *right side panel*. Put a lockwasher and hex nut on each bolt and tighten using a 7/16 inch wrench or socket. (Figure 36)

Note: It is sometimes difficult to get bolts through these four holes. You may need to use a Phillips screwdriver to help shift the parts into place.

12. Repeat steps 10 - 11 with the *left side panel* and the left side of the *shelf*.

13. Turn the *cabinet* so that it is on the *wheels*. Attach the *skirts* to the top of the *side panels*, with one on the front of the cabinet and the other on the back. (Figure 37)

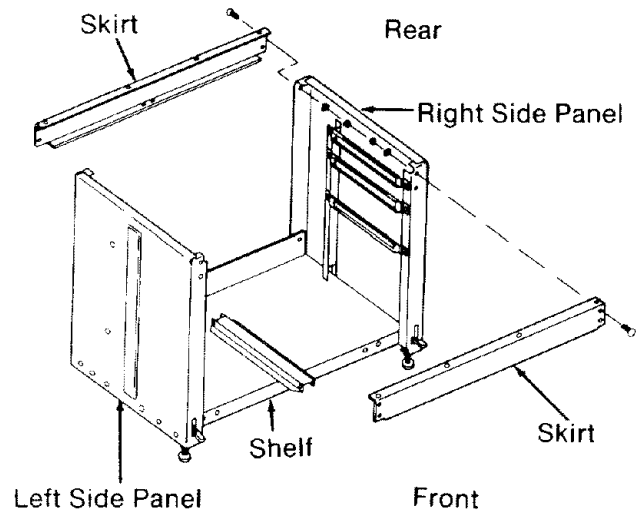

Fig. 37

14. Use eight truss head bolts to hold the *skirts* in place. Put a lockwasher and hex nut on each bolt and hand-tighten. (Figure 37)

15. Put a truss head bolt through the hole at the back, right corner of the *shelf*. This hole goes through the *shelf* and *right side panel*. (Figure 38)

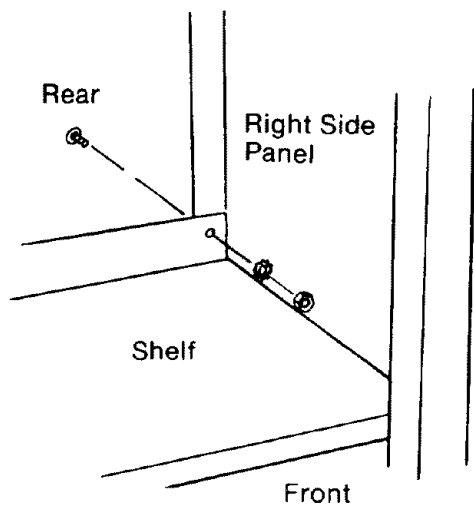

Fig. 38

16. Put a lockwasher and hex nut on the bolt and hand-tighten.

17. Repeat steps 15 - 16 on the left side of the shelf.

18. Unlock the levers on the foot assemblies.

19. Turn the cabinet upside down so that the leveling feet and wheels are pointing up.

20. Put a spacer between the shelf and the right foot assembly.

21. Put a truss head bolt through the foot assembly, spacer, and shelf to hold the spacer in place. (Figures 39 & 40)

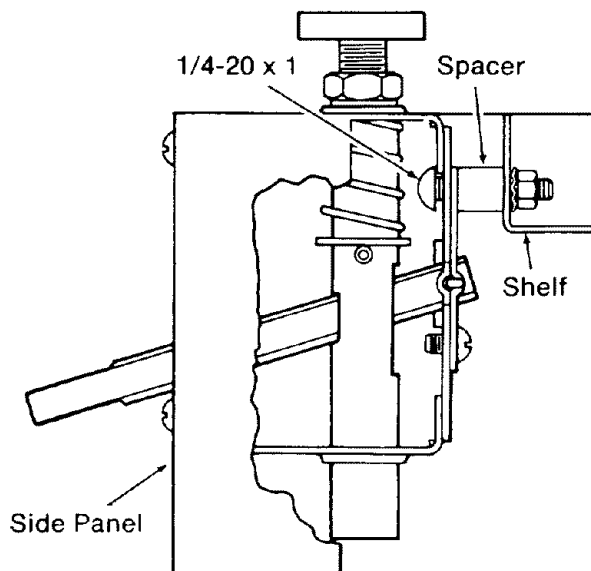

Fig. 39

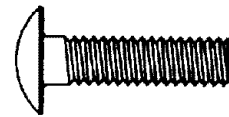

Fig. 40 - Truss Head Bolt

22. Put a lockwasher and hex nut on the bolt and tighten using a 7/16 wrench or socket.

23. Repeat steps 20 - 22 with the left foot assembly.

24. Turn the cabinet back over onto the wheels.

25. Move the cabinet to the location where you will use your saw and push down on foot levers to lock leveling feet in place.

⚠ WARNING: Saw blade can roll forward toward you if the leveling feet are not correctly adjusted. Workpiece or saw can move unexpectedly if cabinet rocks. Fingers, hand or arm can be cut off from blade contact. Adjust leveling feet before using your saw so arm slopes to the rear.

26. If the leveling feet lift the front two wheels slightly off the floor and the cabinet does not rock, go to step 28, or

If the leveling feet do not lift the front two wheels off the floor, or

If the cabinet rocks, go to step 27.

27. Loosen the the hex nut on each leveling foot and rotate until the front wheels are slightly off the floor or until the cabinet does not rock. Then tighten the hex nuts using a 9/16 inch wrench.

28. Put the last rear support in front of you with the long tabs down, short tabs up and solid surface facing you. Attach two slide brackets to each side of this rear support using four truss head bolts. Attach these slide brackets to the holes shown in the figure. Make

sure that you attach the larger hole in each *slide bracket* to the *rear support*. Put a lockwasher and hex nut on each bolt and tighten using a 7/16 wrench or socket. (Figure 41)

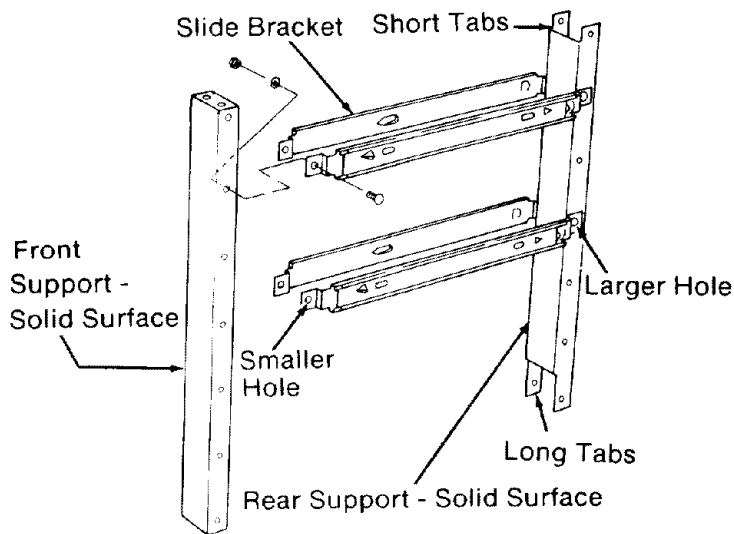

Fig. 41

29. Attach the *front support* to the four *slide brackets* using four truss head bolts. Make sure that the solid surface of the *front support* is facing front. Put a lockwasher and hex nut on each bolt and tighten with a 7/16 inch wrench or socket. (Figure 41)

30. Put the *upper support* in place between the *rear* and *front supports*. Make sure that the *upper support* is inside the surfaces of the other two parts. (Figure 42)

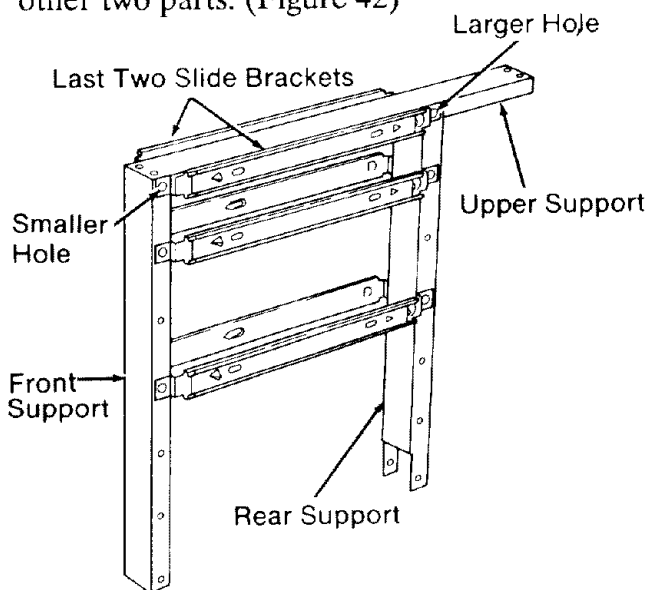

Fig. 42

31. Put the last two *slide brackets* in place on each side of the *front* and *rear supports*. Make sure that the larger holes in the *slide brackets* are in line with the *rear support*. (Figure 42)

32. Attach these *slide brackets* using four truss head bolts. These bolts will go through the *slide bracket*, *rear* or *front support*, and the *upper support*. Put a lockwasher and hex nut on each bolt and tighten using a 7/16 inch wrench or socket.

33. Tilt this whole assembly and slide it into place on the cabinet. Make sure that the *front support* extends between the *front skirt* and the angled end of the *lower support*, and that the *rear support* is inside the cabinet. (Figure 43)

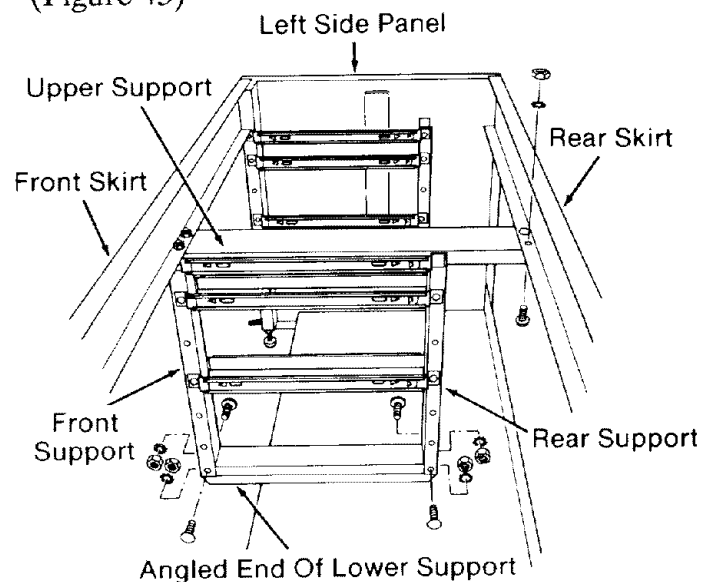

Fig. 43

34. Attach the *upper* and *front supports* to the *front skirt* using two truss head bolts, lockwashers, and hex nuts. Make sure the heads of the bolts point down as shown. (Figure 43)

35. Attach the *upper support* to the *rear skirt* using two truss head bolts, lockwashers and hex nuts. Make sure the heads of the bolts point down as shown. (Figure 43)

36. Attach the *front* and *rear supports* to the *lower support* using four truss head bolts, lockwashers, and hex nuts. (Figure 43)

37. Tighten all screws, except those on the front and rear skirts, using a 7/16 inch wrench or socket.

Putting Drawers Together

The following parts are used to assemble the drawers in model 113.197610:

A.	10 inch Drawers	2
B.	6 inch Drawers	2
C.	3 inch Drawers	2
D.	10 inch Drawer Fronts	2
E.	6 inch Drawer Fronts	2
F.	3 inch Drawer Fronts	2
G.	Center Slide Brackets	12
H.	Stand Slide Brackets	12
I.	Grease Packets	2
J.	Drawer Fastener	48

Note: The center slide brackets and stand slide brackets have already been put together in the Finishing the Cabinet section.

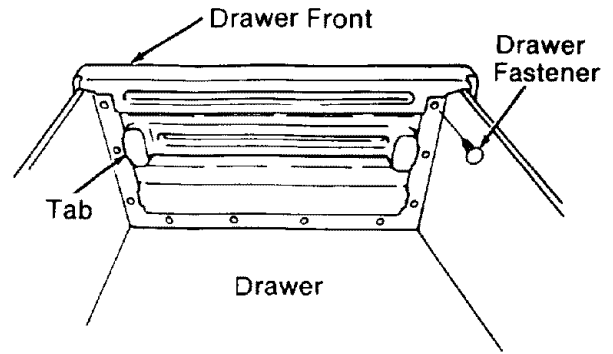

Fig. 45

3. Push a plastic *drawer fastener* into each of the holes to hold the *drawers* together. (Figure 45)

4. Put the *drawers* aside. Do not put the *drawers* into the *cabinet* until after you mount the saw.

Model 113.197410

Building the Cabinet

1. The following parts are used in the cabinet assembly for model 113.197410:

A.	Right Side Panel	1
B.	Left Side Panel	1
C.	Shelf	1
D.	Under Support	1
E.	Skirts	2
F.	Front Shelf Stiffener	1
G.	Corner Brackets	4
H.	Lower Support	1
I.	Spacers	2
J.	Upper Support	1
K.	Front Support	1
L.	Doors	2
M.	Rear Shelf Stiffener	1

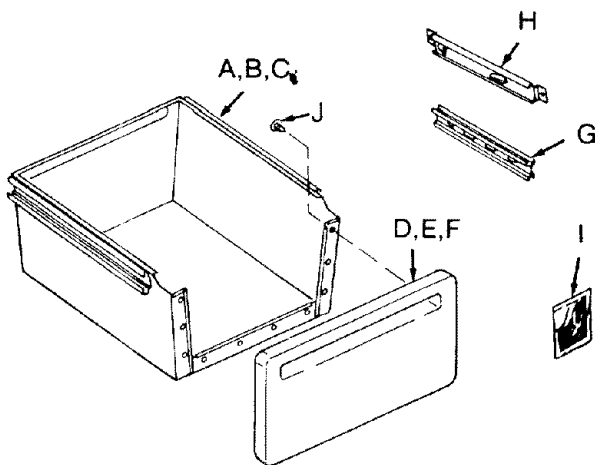

Fig. 44 - Parts for Drawer Assembly

1. Find the six metal *drawers* and plastic *drawer fronts*.

2. Slide the *drawer fronts* onto the *drawers*. Make sure that the tabs on the plastic *drawer fronts* slide over the metal *drawers* to help hold them in place. (Figure 45)

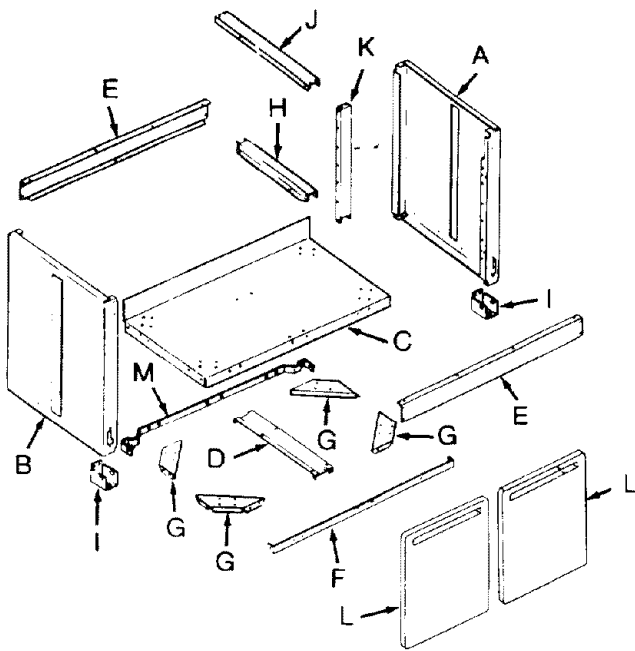

Fig. 46 - Cabinet Assembly - 113.197410

1. Turn the *shelf* upside down on the floor. The wide edge should point down, and the three narrow edges should point up. (Figure 47)

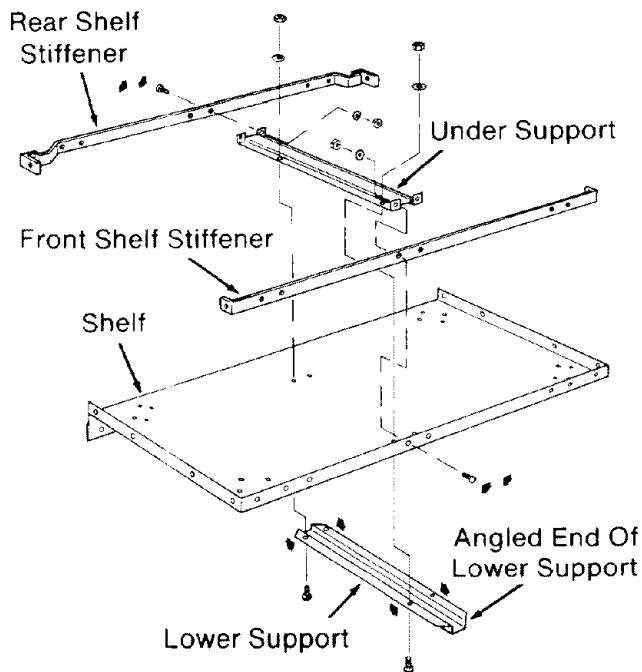

Fig. 47

2. Place the *front shelf stiffener* inside and against the front edge of the *shelf* so that all six holes line up. (Figure 47)

3. Place the *under support* on the *shelf*, so that the two holes on one end line up with the center holes on the other two parts. (Figure 47)

4. Place the *lower support* under the shelf. It should rest directly below the *under support*, with the angled end sticking out. Line up the four holes in these three pieces. (Figure 47)

Note: The angled end of the *lower support* is a useful way to tell the front of the cabinet from the back. The angled end is at the front of the cabinet.

5. Place the *rear shelf stiffener* on the *shelf* so that the two ends fit between the edges of the *shelf*, and the two center holes line up with the holes at the end of the *under support*. (Figure 47)

6. Put truss head bolts through the eight holes indicated. Put a lockwasher and hex nut on each bolt and tighten using a 7/16 inch wrench or socket.

7. Put a *corner bracket* in each corner of the *shelf*. (Figure 48)

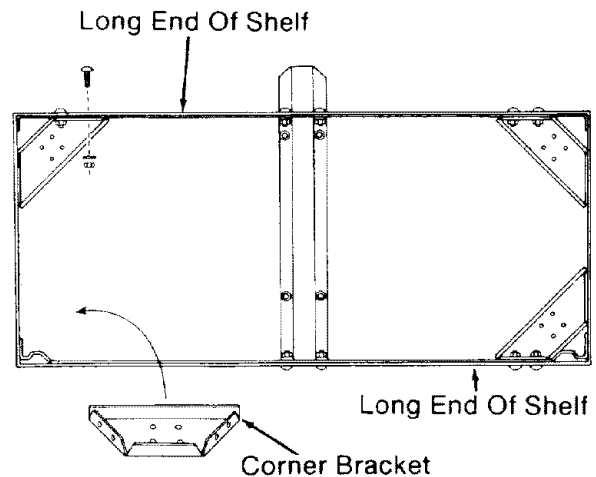

Fig. 48

8. Put two truss head bolts through the *shelf* and each *corner bracket* to hold the brackets in place. Only put bolts through holes in the long edges of the *shelf*, not the narrow ends, as shown. (Figure 48)

9. Put a lockwasher and hex nut on each bolt and tighten using a 7/16 inch wrench or socket.

10. Find the *right* and *left side panels*. Look carefully to find the "R" and "L" stamped in the metal near the center of the wide edge. These stamps are the easiest way to tell the *right side panel* from the *left*. (Figure 49)

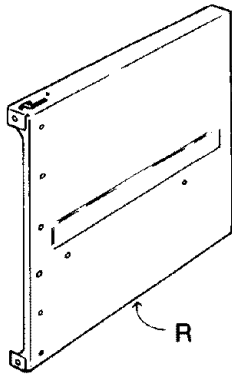

Fig. 49

11. Turn the *right side panel* so that the J-shaped slot is at the bottom and facing you.

12. Put a *spacer* inside the *right side panel* as shown. The side of the *spacer* with two round holes should be opposite the J-shaped slot in the *side panel*, and the side with one larger hole should be on the bottom. (Figure 50)

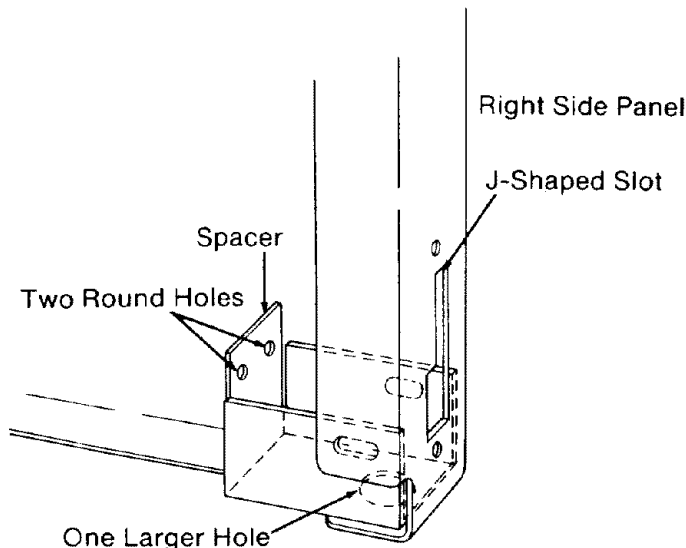

Fig. 50

13. Put two truss head bolts through *right side panel* and *spacer*, one on each side.

14. Put a lockwasher and hex nut on each bolt and tighten using a 7/16 inch wrench or socket.

15. Put a *plastic cover* over the J-shaped slot in the *side panel*. (Figure 50)

16. Attach two *hinges* to the *right side panel* above the *spacer*, using four truss head bolts, lockwashers, and hex nuts. Tighten with a 7/16 inch wrench. (Figure 51)

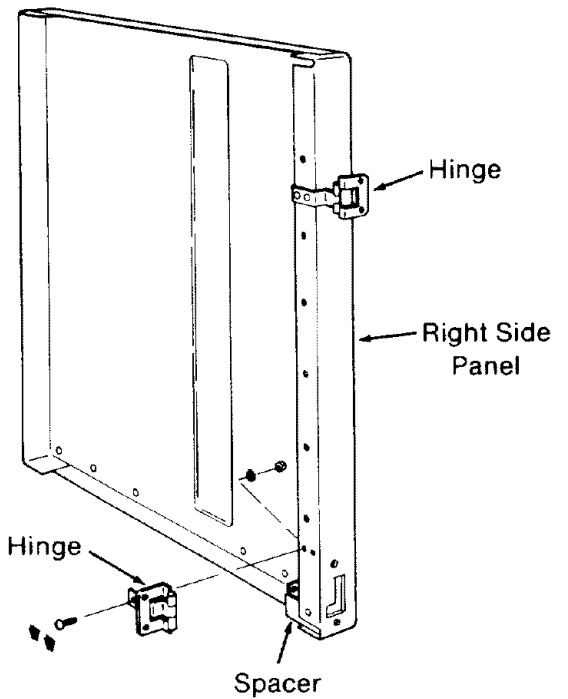

Fig. 51

17. Repeat steps 11-16 with the *left side panel*.

18. Lay the *shelf* on the rear edge with the bottom side toward you. The angled end of the *lower support* should point up.

19. Place the *right side panel* on the right side of the *shelf*. The *spacer* should be on the inside of the cabinet. (Figure 52)

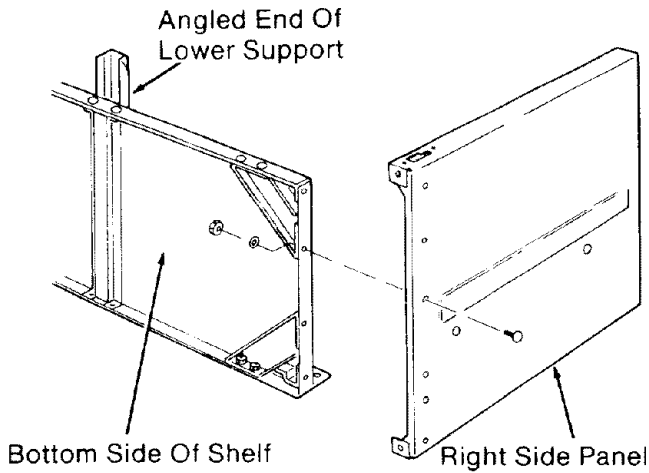

Fig. 52

20. Put bolts through the four holes along the bottom edge of the *right side panel*. Put a lockwasher and hex nut on each bolt and tighten using a 7/16 inch wrench or socket. (Figure 52)

Note: It is sometimes difficult to get bolts through these four holes. You may need to use a Phillips screwdriver to help shift the parts into place.

21. Repeat steps 19-20 with the *left side panel* and the left side of the *shelf*.

22. Turn the *cabinet* right side up. Attach the *skirts* to the top of the *side panels*, with one on the front of the cabinet and the other on the back. (Figure 53)

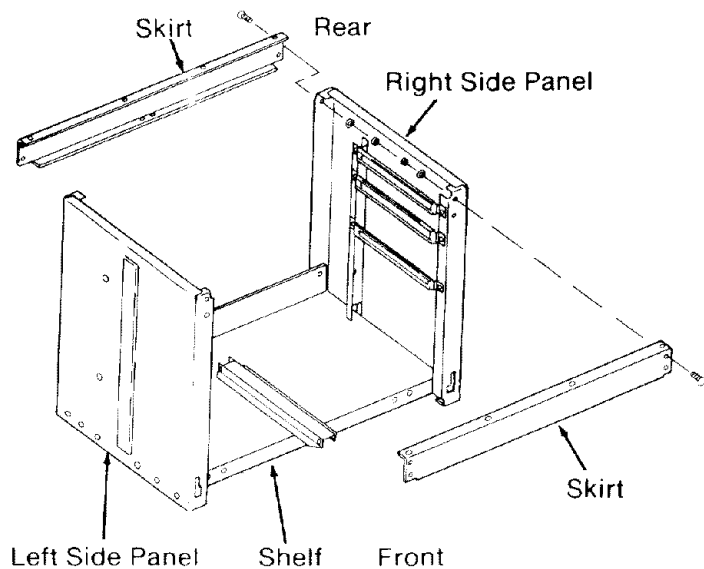

Fig. 53

23. Use eight truss head bolts, lockwashers, and hex nuts to hold the *skirts* in place. Hand-tighten. (Figure 53)

24. Put a truss head bolt through the hole at the back, right corner of the *shelf*. This hole goes through the *shelf* and the *right side panel*. (Figure 54)

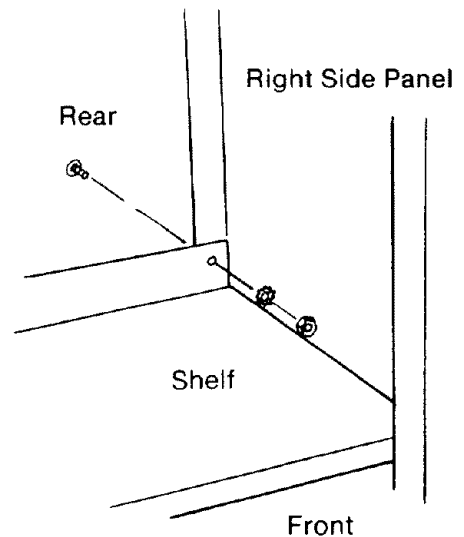

Fig. 54

25. Put a lockwasher and hex nut on the bolt and tighten using a 7/16 inch wrench or socket.

26. Repeat steps 24-25 on the left side of the *shelf*.

27. Put a truss head bolt through the back of the *right spacer* and front edge of the *shelf*. (Figure 55)

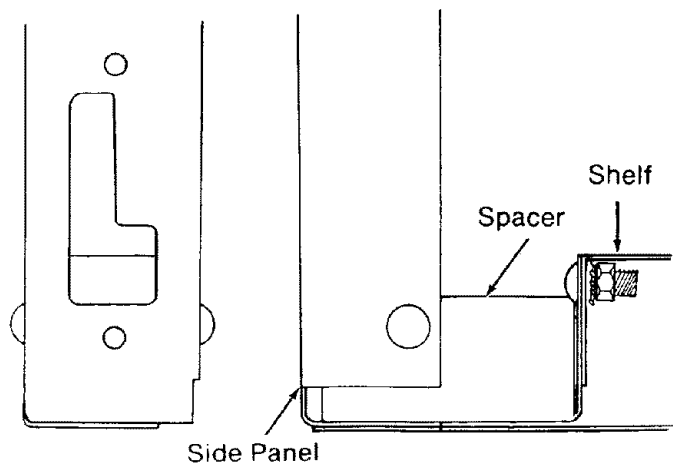

Fig. 55

28. Put a lockwasher and hex nut on the bolt and tighten using a 7/16 inch wrench or socket.

29. Repeat steps 27-28 with the *left spacer*.

30. Move the cabinet to the location where you will use your saw.

31. Put a hex nut on each of the *leveling feet*. (Figure 56)



Fig. 56 - Hex Nut for Leveling Foot

32. Put the *leveling feet* through the holes in the bottom of the *side panels*, at the four corners of the *shelf*.

33. Put another hex nut on each of the *leveling feet* and hand-tighten until they are against the *side panels*.

⚠ WARNING: Saw blade can roll forward toward you if the leveling feet are not correctly adjusted. Workpiece or saw can move unexpectedly if cabinet rocks. Fingers, hand, or arm can be cut off from blade contact. Adjust leveling feet before using your saw.

34. If the *leveling feet* raise the front of the *saw* slightly higher than the rear, **and** if the *cabinet* does not rock, go to step 40, **or**

If the *leveling feet* do not raise the front of the *saw* slightly higher than the rear, go to step 35, **or**

If the *cabinet* rocks, go to step 35.

35. Loosen the bottom hex nut on the desired *leveling foot* using a 9/16 inch wrench.

36. Loosen the top nut by hand.

37. Adjust the lower nut with the 9/16 inch wrench until the *leveling foot* is at the desired height.

38. Tighten the top nut by hand.

39. Repeat steps 35-38 for the other three *leveling feet* if necessary.

40. Tighten all four bottom nuts using a 9/16 inch wrench.

41. Slide the *upper support* into the *front support* to form an inverted L-shaped unit. Four holes in each part should line up: two holes at the top of the "L", and one hole on each side. (Figure 57)

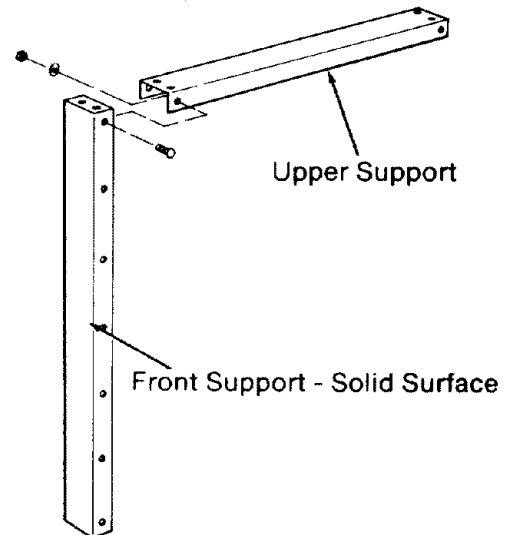

Fig. 57

42. Put two truss head bolts through the holes on the sides of the "L". Put a lockwasher and hex nut on each bolt and hand-tighten.

43. Put the L-shaped assembly into place in the cabinet. The *upper support* should extend between the *front* and *rear* skirts, and the *front support* should extend between the *front skirt* and the angled end of the *lower support*. (Figure 58)

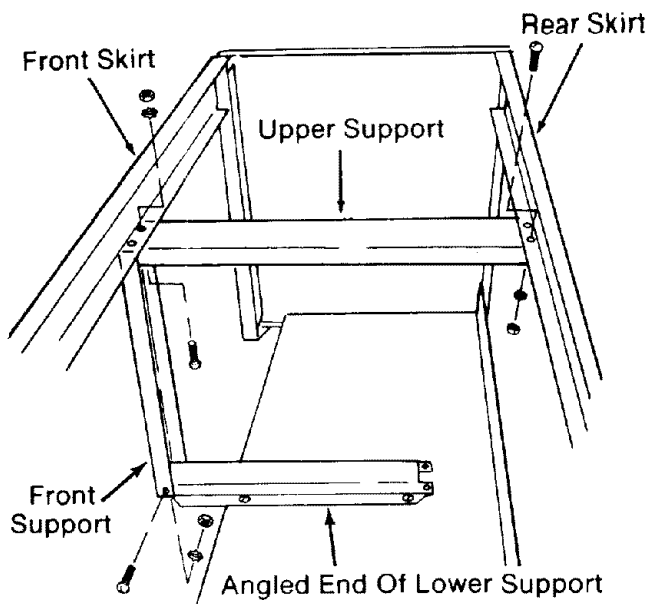

Fig. 58

44. Put two truss head bolts through the *rear skirt* and the *upper support*. Make sure the heads of the bolts point down. Put a lock-washer and hex nut on each bolt and tighten using a 7/16 inch wrench or socket.

45. Put two truss head bolts through the *front support*, *upper support*, and *front skirt*. Make sure the heads of the bolts point down. Put a lockwasher and hex nut on each bolt and tighten using a 7/16 inch wrench or socket.

46. Tilt the cabinet back and put two truss head bolts through the *front support* and the angled end of the *lower support*. Put a lock-washer and hex nut on each bolt and hand-tighten.

Attaching Doors

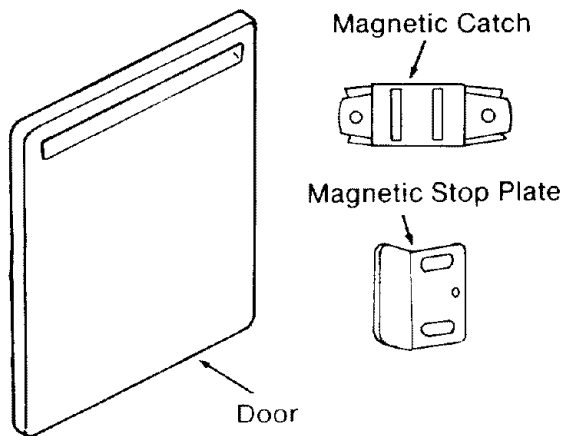

Fig. 59 - Parts for Door Assembly

1. Lay the two *doors* side by side.
2. Put a *magnetic catch* on the inside edge of each *door*. (Figure 60)

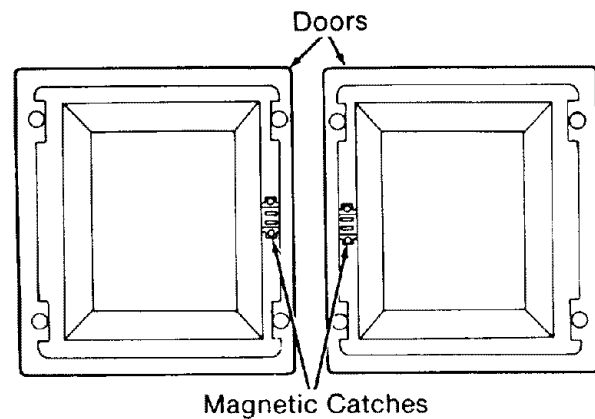

Fig. 60

3. Fasten using four pan head screws. Tighten with a Phillips screwdriver. (Figures 60 & 61)

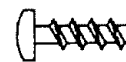

Fig. 61 - Pan Head Screw

4. Attach a *magnetic stop plate* to the two small holes on each side of the *front support* using four pan head screws. Tighten with a Phillips screwdriver. (Figures 62 & 63)

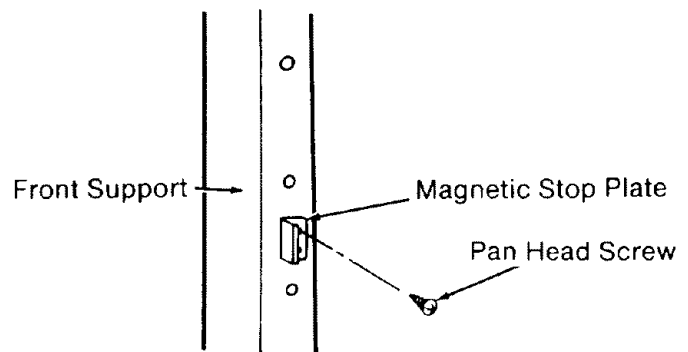

Fig. 62



Fig. 63 - Pan Head Screw

5. Attach the *doors* to the *hinges* on the *side panels* using eight *plastite screws*. Tighten with a *Phillips screwdriver*. (Figure 64)



Fig. 64 - Plastite Screw

Attaching Handwheel

Both Models

1. Locate the handwheel, hex bushing, screw, and lockwasher.
2. Place the hex bushing inside the handwheel.
3. The hex bushing has a small flat on it which matches a flat on the elevation shaft.
4. Align the two above flats and attach the handwheel using a screw and lockwasher.

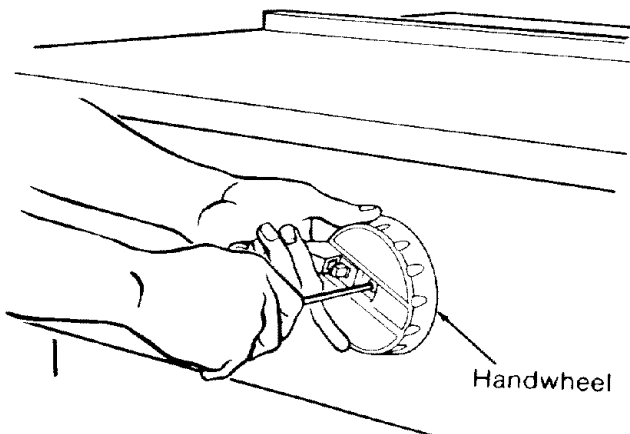

Fig. 65



Fig. 66 - Screw and External Lockwasher

Mounting the Motor

Both Models

⚠ WARNING: Plugging the saw in during assembly can result in electrical shock or your fingers, hand, or arm being cut off from blade contact. Do not plug in the saw at any time during assembly. The saw should only be plugged in when it is to be used.

1. Loosen the *guard clamp screw* and remove the *guard* from the *motor*.
2. Use the *arbor wrenches* to remove the *blade* from the *saw*. The *arbor shaft* has left-handed threads, so you will have to turn the nut clockwise to loosen.
3. Lock the *rip lock*.
4. Turn the handwheel in a clockwise direction to raise the radial arm about 2 inches and remove the styrofoam packing blocks.
5. Clean the small pieces of styrofoam off the saw.
6. Place the *motor* on the center channel of the *saw* and remove the three *table boards* and *fence*.
7. Remove the lock nut and flat washer from the *motor pivot support*. (Figure 67)

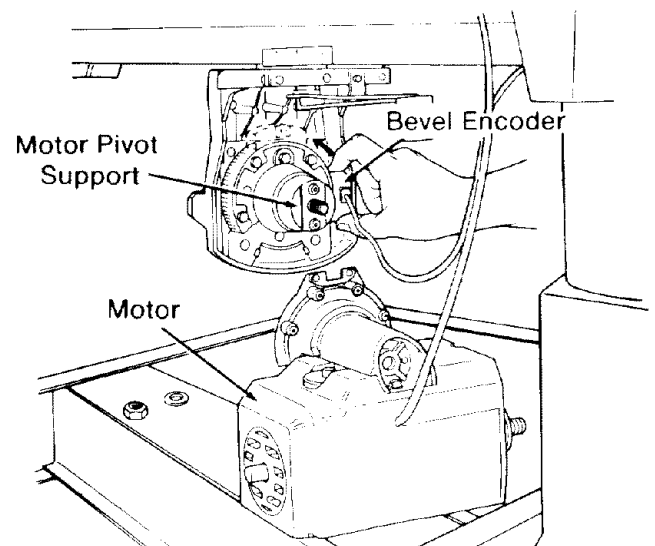

Fig. 67

8. Slide the *bevel encoder* to the top center position so it will fit into the notch on the *motor support bracket*. (Figure 67)

9. Slide the *motor* onto the *motor pivot support*. Make sure that the *motor* is firmly in place.

10. Put the flat washer and locknut back in place and tighten using a 3/4 inch socket wrench. Move the *bevel lock* back and forth as you tighten the locknut. Do not over-tighten.

11. Push the *bevel lock* to the left as far as it will go. (Figure 68)

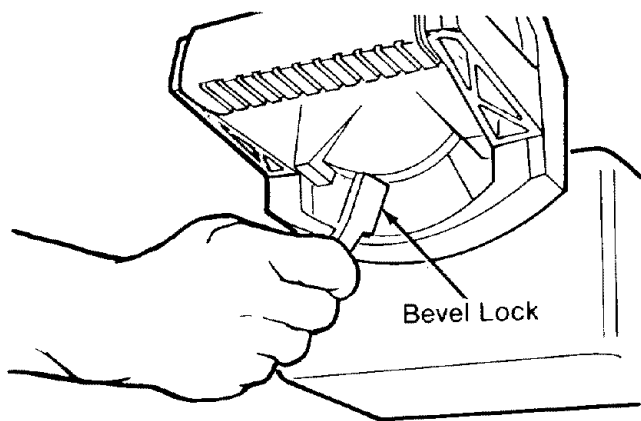

Fig. 68

12. If there is a 1/16 inch gap or less between the *bevel lock* and the left side of the *yoke* (and they are not touching), go to step 14, or

If the *bevel lock* touches the left side of the *yoke*, unlock the *bevel lock* and tighten the locknut on the *motor pivot support*. Then go to step 10 and repeat, or

If there is more than a 1/16 inch gap between the *bevel lock* and the left side of the *yoke*, unlock the *bevel lock* and loosen the locknut on the *motor pivot support*. Then go to step 10 and repeat.

13. Repeat steps 10-11 until the *bevel lock* will not touch the left side of the *yoke*, and the gap is not more than 1/16 inch.

14. Lock the *bevel lock*.

15. Snap the *yoke plug* into place. The *yoke plug* is in the loose parts bag.

Mounting the Saw

Both Models

1. Hold the *saw* by the front edge and the back of the column support, and lift it onto the cabinet. Make sure that eight holes in the bottom of the *saw* line up with eight holes in the top of the cabinet.

2. Fasten the *saw* to the cabinet with eight truss head bolts. Put a lockwasher and hex nut on each bolt and tighten using a 7/16 inch wrench or socket. (Figure 69)

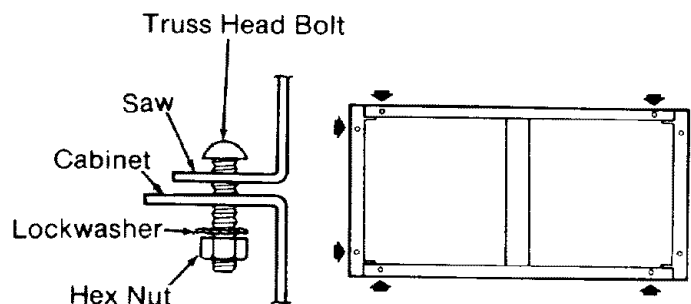

Fig. 69

3. Check all the nuts holding the cabinet together and tighten them using a 7/16 inch wrench or socket.

Attaching Trim Caps

Both Models

1. Find the left and right trim caps.

2. There are two plastic stubs on the back of each trim cap.

3. These stubs will snap into matching holes at the front corner of each saw.

4. Snap the left and right trim caps into place.

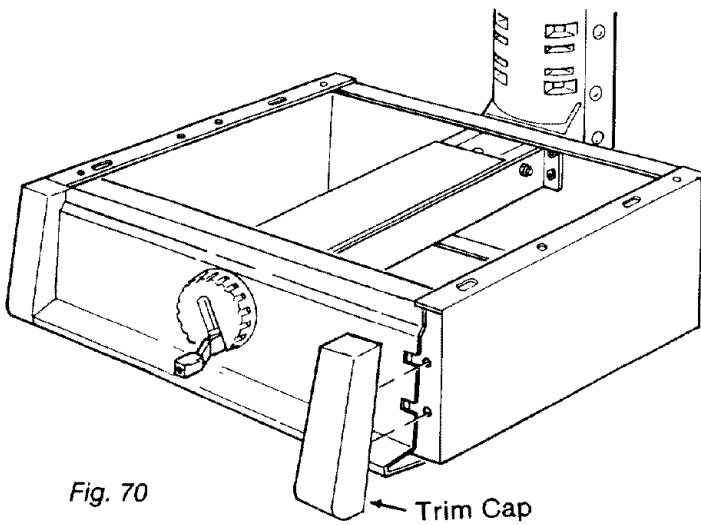

Fig. 70

Mounting Small Table Rails Both Models

The following parts are used to mount the small table rails:

- A. Small Table Rail 2
- B. Locking Handle 2
- C. 1/4-20x1-1/8 Bolts 4
- D. 1/4 Lockwashers 4
- E. 1/4-20 Hex Nuts 4

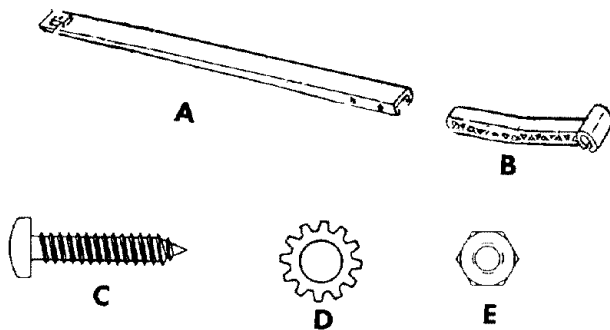

Fig. 71

1. Place black plastic locking handle through one of the rectangular shaped holes in the front of the saw.
2. Attach small table rail to handle with two 1/4-20x1-1/8 bolts, washers, and nuts. Open side of channel faces down.

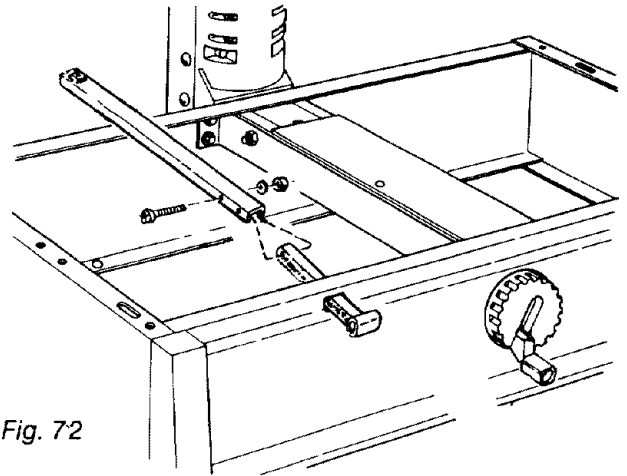

Fig. 72

3. Repeat steps 1 and 2 on the other side of the saw.

Mounting Large Table Rails Both Models

The following parts are used to mount the large table rails:

- A. Large Table Rail 2
- B. Pan Head Screws 1/4x5/8 4
- C. Front Table (44"x17") 1

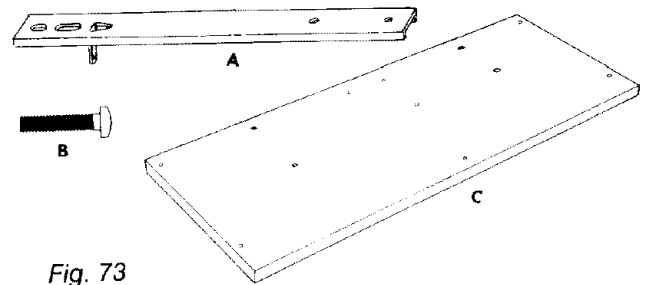

Fig. 73

1. Turn the front table (44"x17") upside down. The top of the front table has five large holes and nine smaller ones. This side should be toward the floor.
2. Place the two large table rails on the front table as shown. The flat side of the rail should be against the table and the "L" bracket points up. Fasten in place with two 1/4 x 5/8" panhead screws but do not tighten yet.

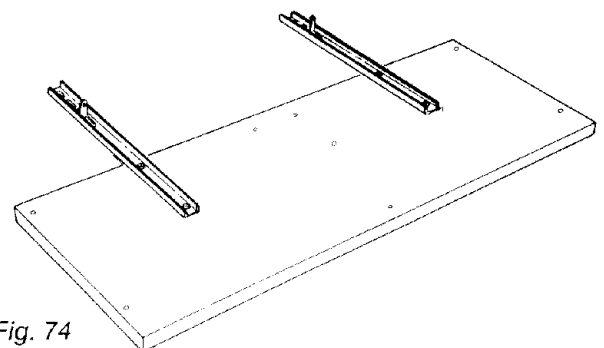

Fig. 74

Mounting the Front Table

Both Models

The following parts are used to mount the front table:

- A. Tee Nuts3
- B. U-Clips, 1/4-205
- C. Mounting Screws, 1/4-20x1-3/45
- D. Rubber Grommets5
- E. Hex Nuts, 1/4-202
- F. Washers, 17/64-5/8x1/325
- G. Bolt, 1/4-20x14
- H. Washer, 1/44

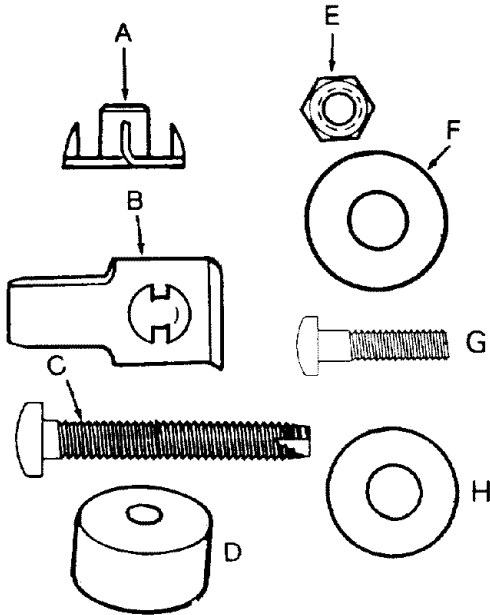

Fig. 75 - Parts for Mounting Table

1. Place a *tee nut* over each of the *leveling holes* and hammer them into place. (Figure 76)

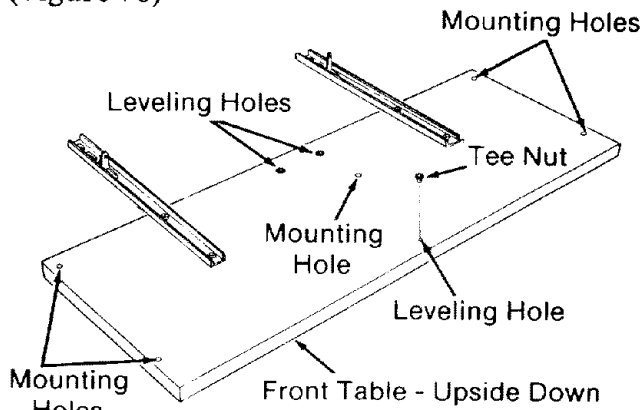

Fig. 76 - Leveling and Mounting Holes

2. Slide four *U-clips* over the holes in the *saw* as shown. (Figure 77)

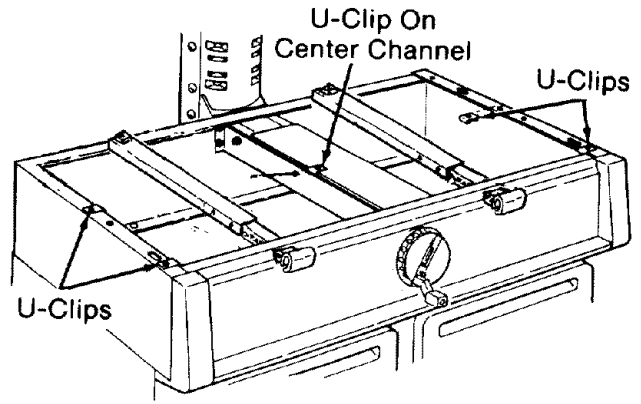

Fig. 77

3. Slide one *U-clip* over the hole in the left side of the center channel as shown. (Figure 77)

4. Put a *washer* on each of the *mounting screws*. (Figure 78)

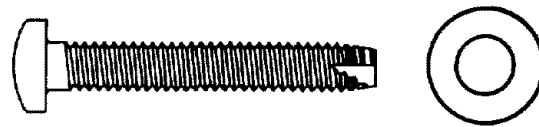

Fig. 78 - Mounting Screw and Washer

5. Stand the *front table* on one edge.

6. Put a *mounting screw* through each of the *mounting holes*. Then put a *rubber grommet* on the bottom of each *mounting screw*. (Figure 79)

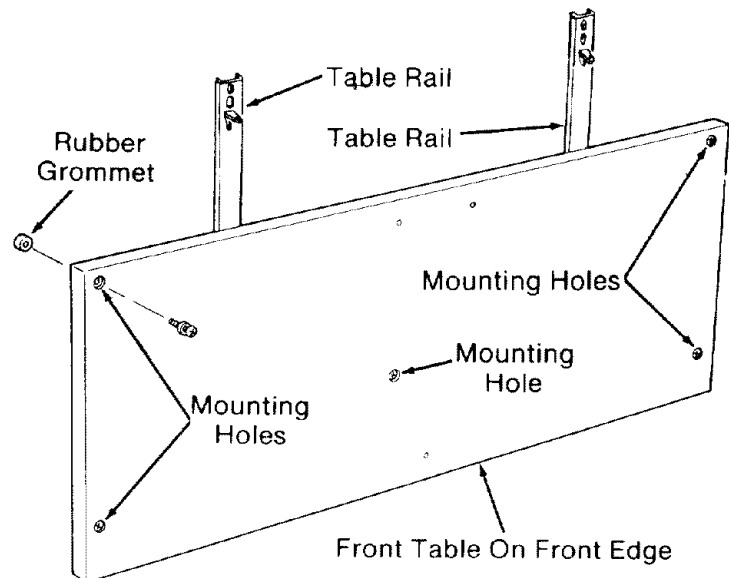

Fig. 79

7. Place the *front table* on the *saw* so that the *mounting screws* line up with the *U-clips*. The *front table* should extend about one inch beyond the *trim caps*.

8. Start the *mounting screws* into the *U-clips* using a Phillips screwdriver. Tighten the screws until the heads are just touching the table. Make sure that the table is not squeezing the rubber grommets.

9. Start the *leveling screws* into the *leveling holes* using a 1/8 inch Hex-L wrench. Tighten the screws until they are flush with the *table*.

10. Push the *large rail* (previously fastened to bottom of table) towards the *front of the saw* and fasten the "L" bracket to the *back of the saw* with a 1/4-20x1 bolt, flat washer, and nut.

11. Tighten the 5/8 inch long *pan head screw* that was used to fasten the *large rail* to the bottom of the *table top*.

12. Repeat steps 10 & 11 on the other side of the saw.

Assembling Table Lock Mechanism

Both Models

The following parts are used to assemble the table lock mechanism:

- | | | | |
|----|------------------------|-------|---|
| A. | Pivot Arm/Cam | | 2 |
| B. | Steel Spacer | | 2 |
| C. | Screw, 1/4-20x1-1/8 | | 2 |
| D. | Screws 1/4-20x5/8 | | 2 |
| E. | Washers, 1/4 | | 4 |
| F. | Hex Nut, 1/4-20 | | 2 |
| G. | Square Locknut, 1/4-20 | | 2 |
| H. | Lockwashers 1/4 | | 2 |

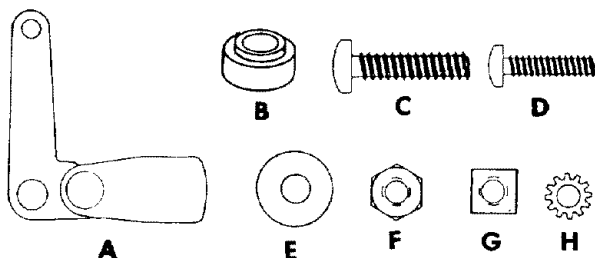

Fig. 80 - Parts for Assembling Table Lock Mechanism

1. The *steel spacer* has a smaller end that fits into the large hole on the *pivot arm/cam*. Snap the spacer in place.

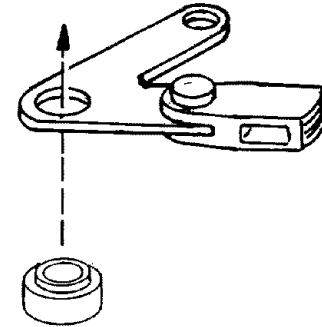

Fig. 81

2. Drop pivot arm/cam in slot in *large rail* and turn until the round "nose" of cam faces the *front of the saw* and the pivot arm is in the rear.

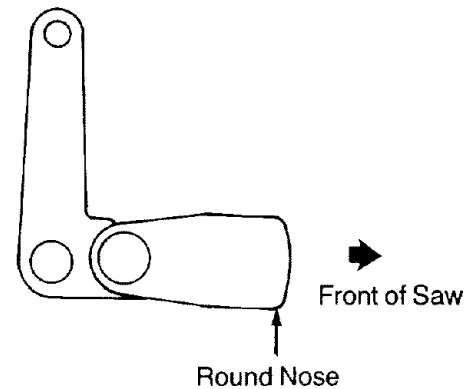

Fig. 82

3. Place a 1/4 washer on a 1/4-20x1-1/8 bolt. Place bolt through *pivot arm/cam* and *large table rail*. Place a second washer on bolt 1/4 lockwasher then a hex nut and tighten in place.

4. Attach the *small hole* in the back of the *pivot arm* to the *stepped insert* on the *small table rail*. Use a 1/4-20x5/8 bolt and a square lock nut.

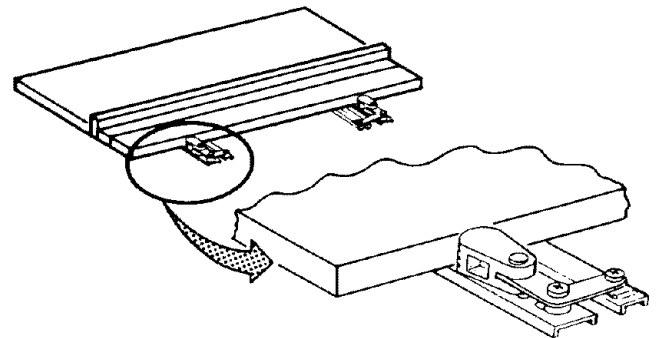

Fig. 83 - Completed Assembly

Putting Drawers in Place

Model 113.197610

1. Slide each *drawer* in place on the *slide brackets* and push them all the way in.
2. Then pull each *drawer* out as far it will go. The *drawers* should not come all the way out.
3. If any of the *drawers* do come all the way out, use a screwdriver to bend out the stop tabs on the *slide brackets*. (Figure 84)

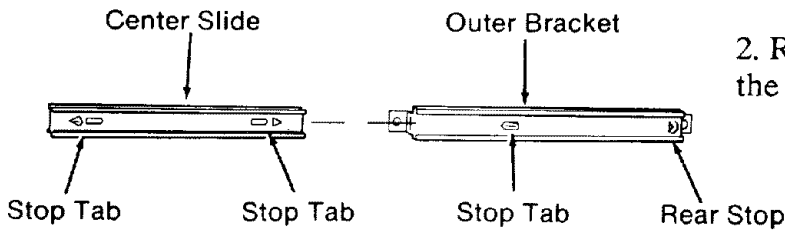

Fig. 84 - Stop Tabs

4. Try the *drawer* again.
5. Repeat until none of the *drawers* fall out.

Removing Drawers

Model 113.197610

If you need to remove a drawer for any reason, do the following:

1. Use a screwdriver to push in one of the stop tabs on the right *slide bracket*. Pull the *drawer* out slightly as you do this.
2. Repeat with the left *slide bracket* and pull the *drawer* all the way out.

Location and Function of Controls

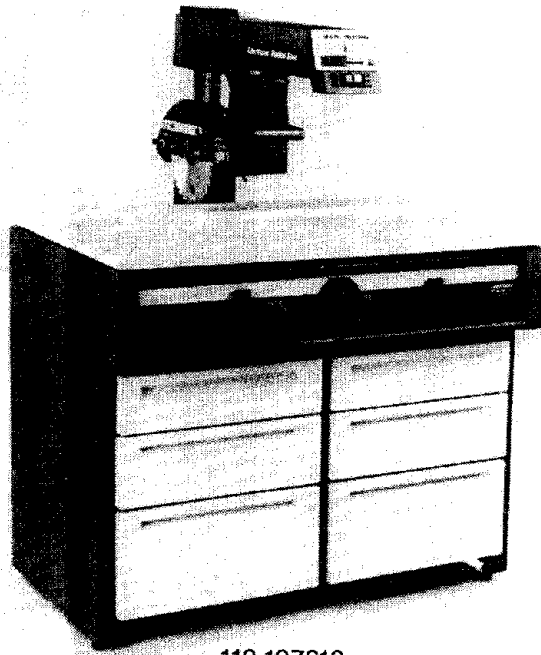

113.197610

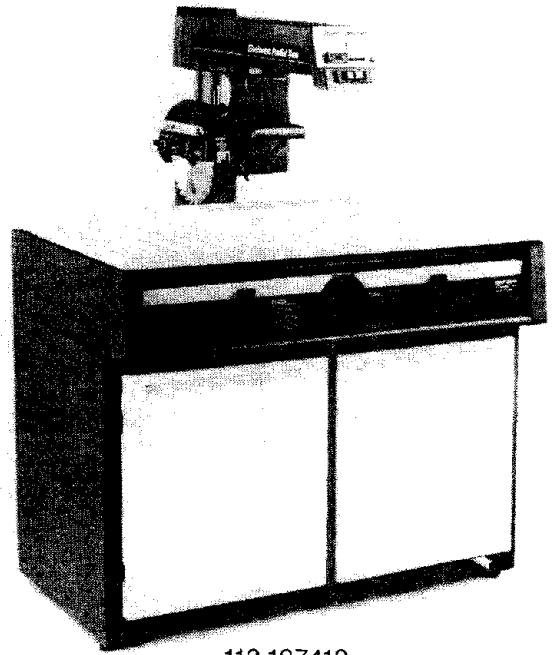

113.197410

Fig. 85 - Radial Saw Controls

On/Off Switch

The on/off switch turns the power to the saw on and off.

To turn the saw on, put the *yellow key* into the *red switch* and then pull the *switch* to the right. To turn the saw off, push the *red switch* to the left. Remove the *yellow key* from the *red switch* whenever the saw is turned off, and keep it out of the reach and sight of children. (Figure 86)



Fig. 86 - On/Off Switch

⚠ WARNING: The saw can start accidentally or be used by children and others when the yellow key is left in the red switch. Always remove the yellow key when the saw is off, and keep it out of the reach and sight of children.

⚠ WARNING: The saw will start immediately when the power comes back on after a blackout if the red switch is left on. Always turn the switch off and remove the yellow key when the power goes off for any reason.

Miter Lock

The miter lock is used to hold the radial arm at various angles to the fence.

To unlock the *miter lock*, pull the lock to the right. (Figure 87)

Bevel Lock

The bevel lock is used to hold the blade at various angles to the table. To unlock the *bevel lock*, move the lock to the right. Always hold the *motor* when you unlock the *bevel lock*. (Figure 89)

⚠ CAUTION: The motor is heavy and can swing down quickly. You can be cut or injured by the arbor shaft or blade. Hold the motor when you unlock the bevel lock.

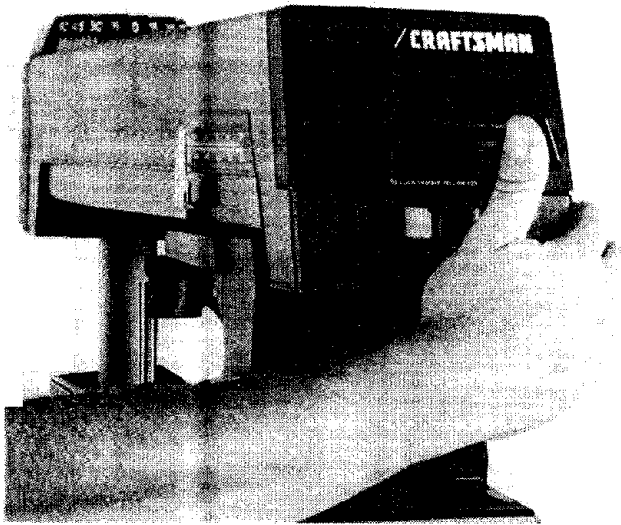

Fig. 87 - Miter Lock - Unlocked

To lock the *miter lock*, push the lock to the left. (Figure 88)

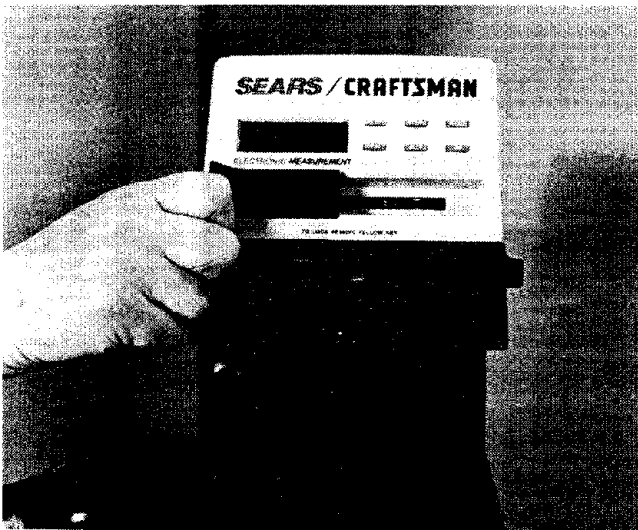

Fig. 88 - Miter Lock - Locked

There are three pre-set miter angles at 45° , 0° , and -45° . You will feel the radial arm snap into position at these miter angles. To unlock the arm when it is in one of these positions, pull the *miter lock* all the way to the right and move the *arm* as you hold the *lock* in this position.

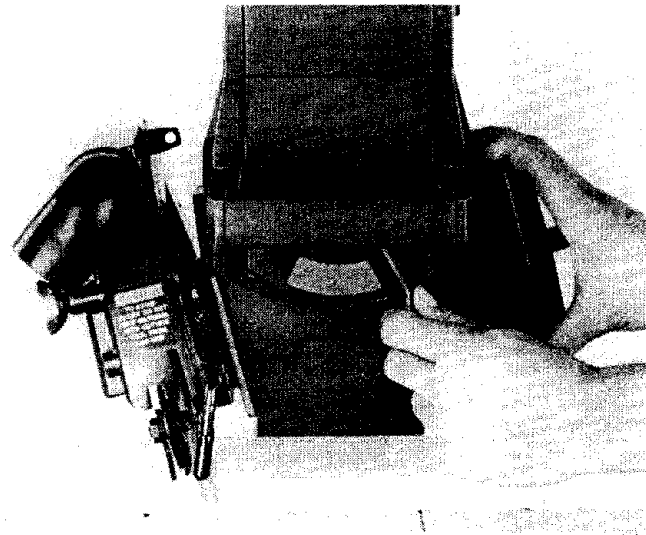

Fig. 89 - Bevel Lock - Unlocked

To lock the *bevel lock*, move the lock to the left. (Figure 90)

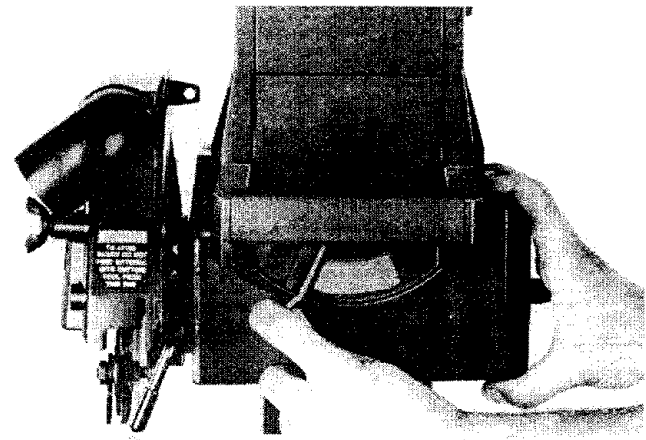

Fig. 90 - Bevel Lock - Locked

There are five pre-set bevel angles at -90° , -45° , 0° , 45° , and 90° . To unlock the *bevel lock* when the blade is at one of these angles, move the *bevel lock* all the way to the right and turn the *motor* while holding the *lock* in this position.

Swivel Lock

The swivel lock is used to hold the blade in the crosscut, in-rip, or out-rip positions, and to position the blade for molding or edging. To unlock the *swivel lock*, stand facing the *saw handle* and pull the *swivel lock* toward you. (Figure 91)

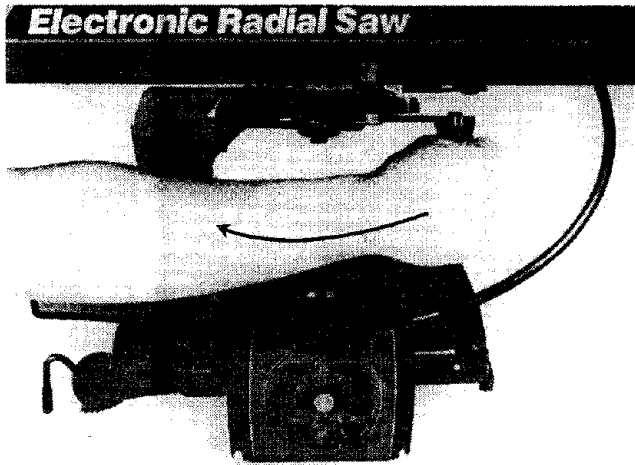

Fig. 91 - Swivel Lock - Unlocked

To lock the *swivel lock*, stand facing the *saw handle* and push the *swivel lock* away from you. (Figure 92)

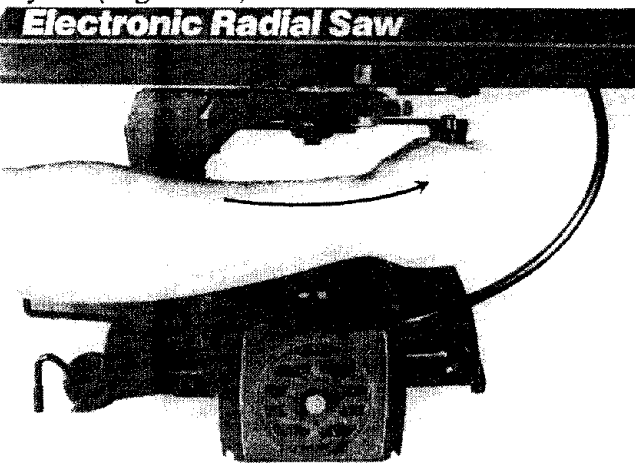

Fig. 92 - Swivel Lock - Locked

The crosscut, in-rip, and out-rip positions of the blade are pre-set positions. To unlock the

swivel lock when the *motor* is in one of these positions, stand facing the *saw handle*, pull the *swivel lock* all the way toward you, and turn the *motor* as you hold the *lock* in this position.

Rip Lock

The rip lock is used to hold the motor and blade at a fixed position along the radial arm. It is used during ripping to hold the blade a desired distance from the fence while the workpiece is fed through. It is used before and after each crosscut to keep the blade from moving forward on its own.

To unlock the *rip lock*, pull the handle toward the front of the *arm*. (Figure 93)

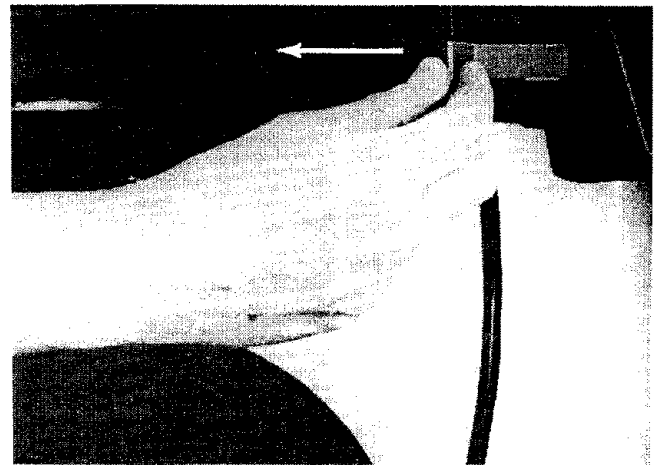

Fig. 93 - Rip Lock - Unlocked

To lock the *rip lock*, push the handle toward the rear of the *arm*. (Figure 94)

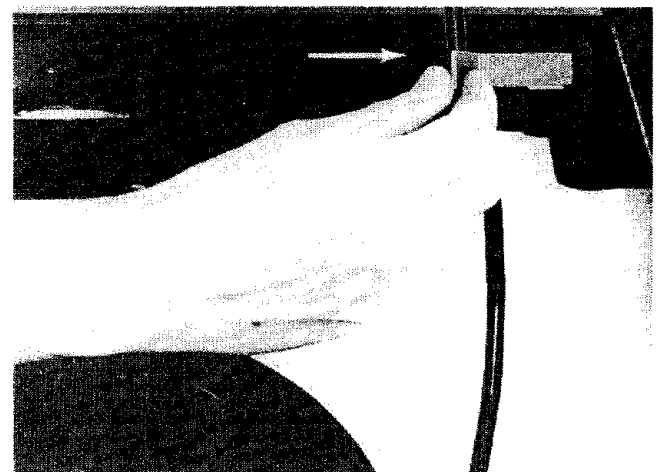

Fig. 94 - Rip Lock - Locked

Handwheel

The handwheel controls the height of the radial arm.

To raise the *radial arm*, turn the *handwheel* clockwise. To lower the *radial arm*, turn the *handwheel* counterclockwise. (Figure 95)

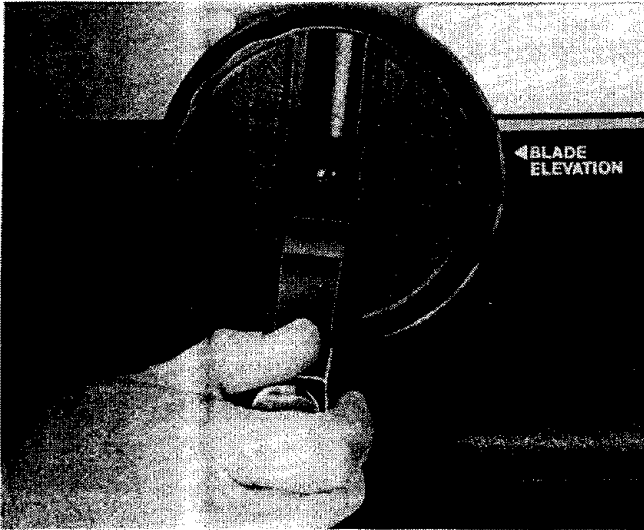

Fig. 95 - Handwheel

One complete turn of the handwheel moves the arm 1/16 inch.

The handle can be folded in by squeezing the *red plastic "ears"* with your thumb and index finger while pushing the handle in.

All Controls

Always lock the miter, swivel and bevel locks before making a cut on your radial arm saw. When ripping, the rip lock must also be locked. When crosscutting, the rip lock should be locked before and after each cut, when the saw is in the rearmost position.

Alignment of the Blade

ALIGNMENT OF THE BLADE IS THE **MOST IMPORTANT STEP** IN ASSEMBLING YOUR RADIAL ARM SAW.

The blade of your radial arm saw must be aligned properly for two reasons: to make cuts accurate, and to prevent binding of the blade and workpiece which can cause jams or thrown workpieces.

These adjustments must be done **in order**, before using your saw for the first time. If they are not done in order the saw will not cut accurately. If you miss an adjustment, you must go back to the adjustment you missed and repeat **all** steps from that point on.

These adjustments are like fine tuning a piece of equipment. Often a series of steps must be repeated more than once in order to get the adjustment just right.

⚠ WARNING: Plugging the saw in during alignment can result in electrical shock or your fingers, hand, or arm being cut off from blade contact. Do not plug in the saw at any time during alignment. The saw should only be plugged in when it is to be used.

Make sure that the blade and blade guard are removed from the arbor shaft before beginning to align your saw. Do not install the blade or blade guard until you are instructed to do so.

Adjusting Elevation

The goal of this adjustment is to make upward and downward movement of the radial arm smooth and firm. If the column that supports the arm is too tight it will be difficult to move the arm up and down and to get accurate depth of cut. If the column is loose the blade may "walk" on the workpiece and stall the motor, or cause a heel in bevel and compound cuts.

1. Use a $3/16$ " hex "L" wrench to loosen the four screws in the front of the *column support*. (Figure 96)

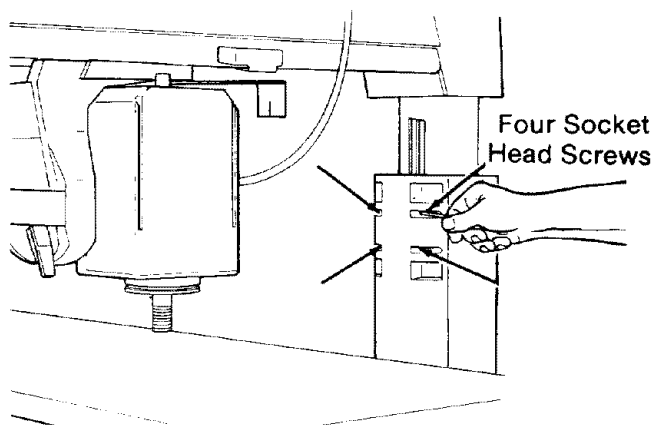

Fig. 96

2. Raise and lower the *radial arm* by turning the *handwheel* a few turns in each direction. It should take about the same amount of effort to lower the *arm* as to raise it.

3. **If** movement seems smooth and the *column* does not rock back and forth, use a $3/16$ allen wrench to retighten the four screws in the front of the column support. (Figure 96). Do not over tighten or it will be difficult to raise and lower the radial arm. After completing these steps go on to the next section, **or**

If movement seems difficult, loosen the four bolts in the back of the *column* slightly (Figure 97) and go back to step 2, **or**

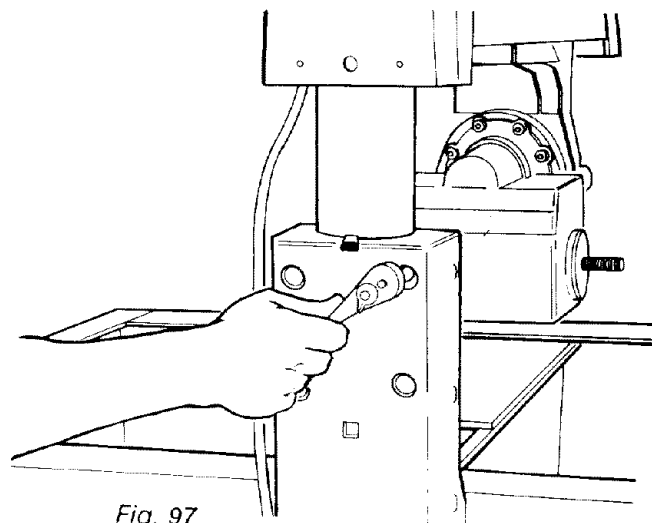

Fig. 97

If *column* rocks back and forth, tighten the four bolts in the back of the *column* slightly (Figure 97) and go back to step 2.

Leveling Front Table.

The goal of this adjustment is to make the front work table flat and parallel to the radial arm. In order to do this, you will choose four points on the table. When these four points are level, the entire table should be level. You will use two methods to make the four points level:

- Tighten the *mounting screws* which pull down on the table making a given point lower. (Figure 98)
- Tighten the *leveling screws* which push up on the table making a given point higher. (Figure 98)

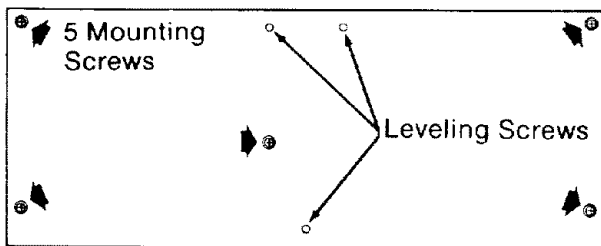

Fig. 98

1. Loosen the three *leveling screws* and be sure that the five *mounting screws* are snug but not overtightened.

2. Raise the *radial arm* until the bottom of the *motor* is about 2-1/2 inches above the *front table*.

3. Unlock the *bevel lock* to release the *motor*. Hold onto the *motor* as you do this.

CAUTION: The motor is heavy and can swing down quickly. You can be cut or injured if the arbor shaft hits you. Hold the motor when you unlock the bevel lock.

4. Turn the *motor* until the *arbor shaft* is pointing straight down toward the *table*. (Figure 99)

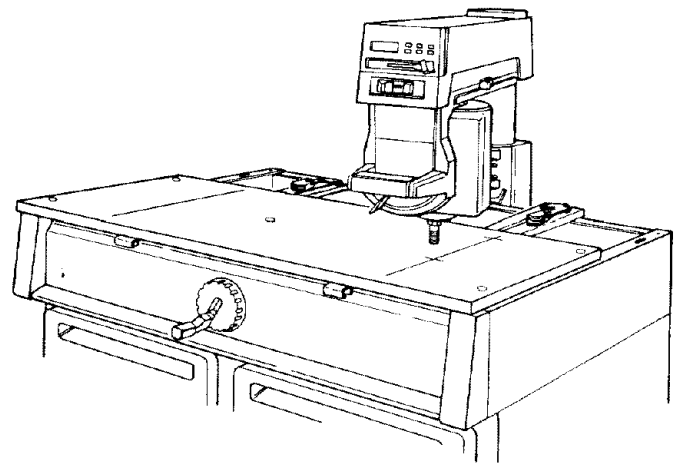

Fig. 99

5. Lock the *bevel lock* to hold the *motor* in this position.

6. Draw two lines on the *front table*, over the *table rails*. (Figure 99)

7. Unlock the *rip lock* and pull the *motor* out to the end of the *arm*.

8. Unlock the *miter lock* and swing the *arm* to the right until the *arbor shaft* is over the right line at the front of the table.

9. Mark the point on the line under the center of the *arbor shaft*.

10. Move the *arm* and *motor* until the *arbor shaft* is over the right line at the rear of the *front table*.

11. Mark the point on the line under the center of the *arbor shaft*.

12. Repeat steps 7-11 on the left side.

13. Label the points A, B, C, and D.

14. Move the *arbor shaft* over these points again, and measure the distance between the *table* and the bottom of the *arbor shaft* at each. Do not change the elevation of the *arm* as you move from point to point.

15. Determine which point has the largest distance between the *table* and the *arbor shaft*. This is the lowest point.

16. Move the *arbor shaft* over the lowest point.

17. Place the handle end of the *arbor wrench* over this point and lower the *arm* until the *arbor shaft* is just touching the *wrench*. The *wrench* should slide back and forth with slight contact. (Figure 100)

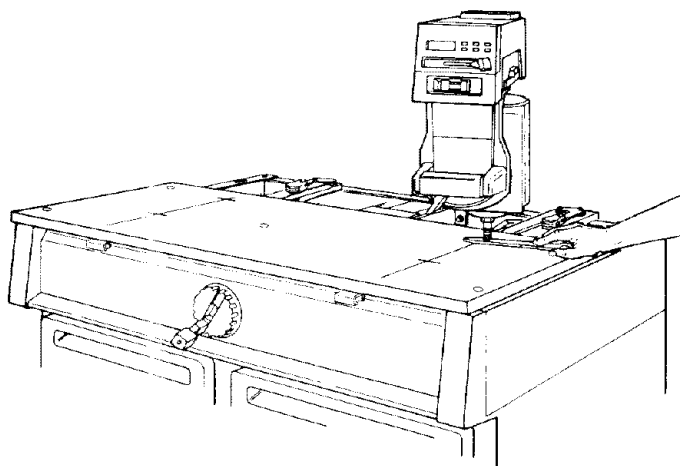

Fig. 100

18. Move the *arbor shaft* over another point. Do not change the elevation of the *arm*.

19. Tighten the *mounting screws* and/or *leveling screws* until the handle of the *arbor wrench* just fits between this point and the *arbor shaft*. The *wrench* should slide back and forth with slight contact. Use a 1/8 inch Hex-L wrench to tighten the *leveling screws*.

20. Repeat steps 18-19 for the last two points.

21. Lay the edge of the *rear table* across the front edge of the *front table*. There should be no gaps between the two.

22. If you see a gap larger than 1/32 inch, tighten the center *mounting screw* and/or the *leveling screws* until the gap is gone. Use a 1/8 inch Hex-L wrench to tighten the *leveling screws*. (Figure 101)

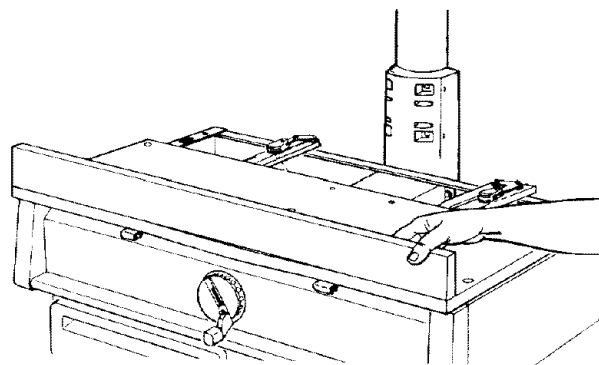

Fig. 101

23. Repeat steps 21-22 at the rear edge of the *front table*.

24. Unlock the *bevel lock* and return the motor to its original position with the *arbor shaft* parallel to the *table*. (Figure 102)

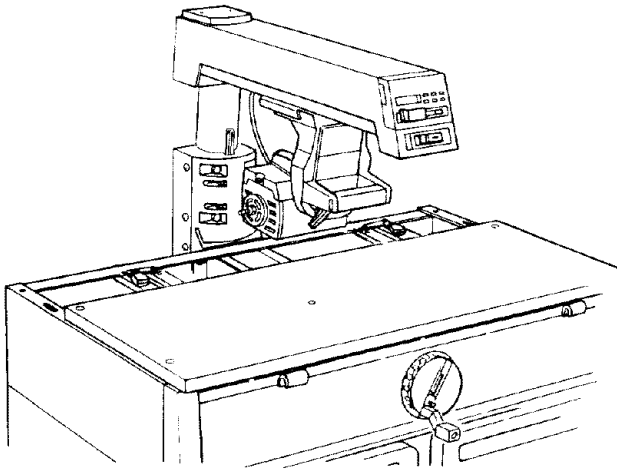

Fig. 102

25. Lock the *bevel lock*, *rip lock*, *swivel lock* and *miter lock*.

Squaring Crosscut Travel

The blade must travel perpendicular to the fence along the radial arm in order for crosscuts to be accurate. If the radial arm is not perpendicular to the fence, there will be a slight miter angle in all crosscuts.

⚠ WARNING: Plugging in the saw during alignment can result in your fingers, hands, or arm being cut off from blade contact. Do not plug in the saw at any time during alignment. The saw should only be plugged in when it is to be used.

1. Place the *radial arm* in the 0° miter position and lock the miter lock.
2. Raise the *radial arm* about 2 inches above the front table.
3. Unlock the *bevel lock*, and turn the *motor* so that the *arbor* is perpendicular to the *table*. (Figure 103)

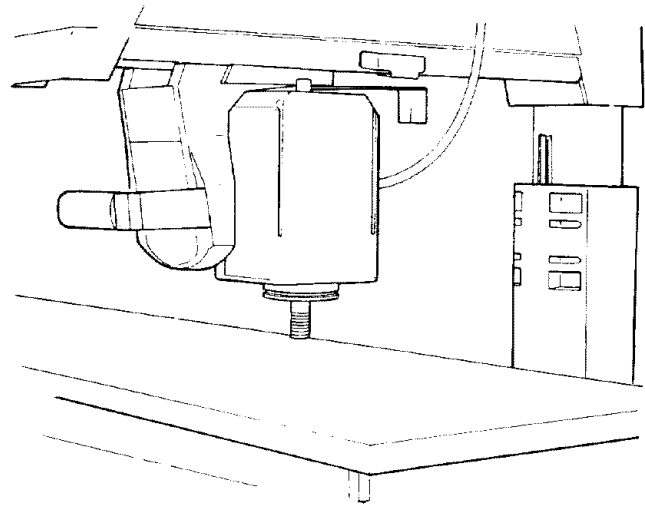

Fig. 103

4. Unlock the *rip lock* and move the *motor* until the *motor arbor* is over the *front table*.

5. Lock the *rip lock*, *miter lock* and *bevel lock*.

6. Lower the *radial arm* until the *motor arbor* is slightly above *front table*.

7. Lay a framing square on the *front table* with the long edge along the back of the *table* and the short edge alongside the *motor arbor*. (Figure 104)

8. Move the framing square toward the *motor arbor* until the arbor and square touch each other. (Figure 104)

9. Unlock the *rip lock* and move the *motor arbor* back and forth along the *radial arm* as shown by the arrows. Do not move the framing square.

10. If the *motor arbor* just touches the square at all points, no change is needed. Go to step 14, or

If the *motor arbor* moves away from the square or tries to “walk” on top of it, go to step 11. (Figure 104)

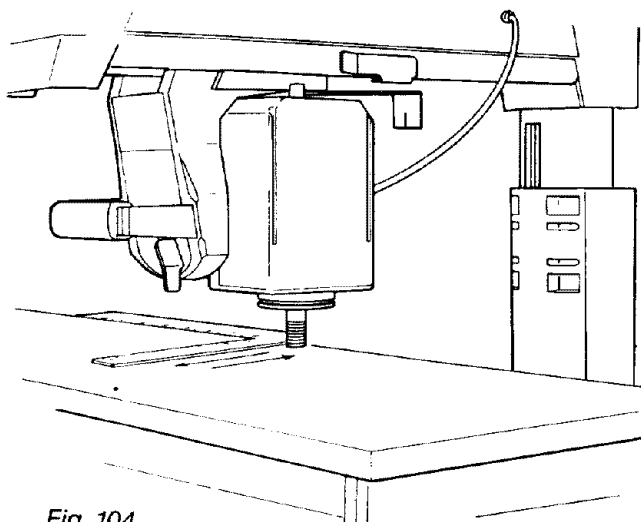

Fig. 104

11. Find the four screws in front of the column support (Fig. 105). Use a 3/16 hex “L” wrench to adjust these screws as described below.

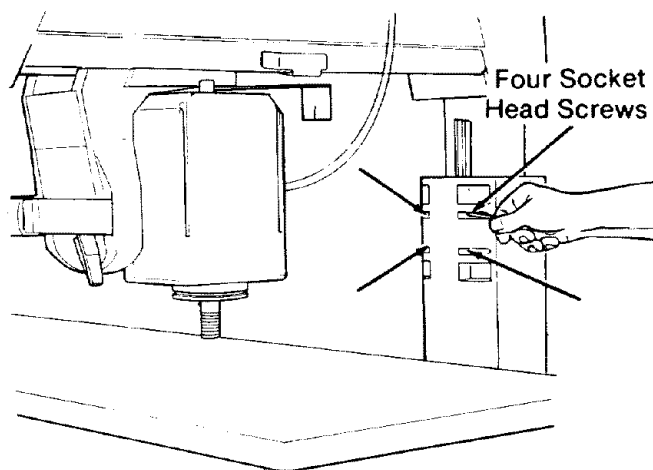

Fig. 105

12. Slightly loosen the bottom two screws.

13. Use the top two screws to move the *radial arm* into line:

If the *motor arbor* moved away from the square, loosen the top left screw. Then tighten the top right screw to move the arbor towards the square. Go to step 14, or

If the *motor arbor* tried to “walk” on the square, loosen the top right screw. Then tighten the top left screw to move the arbor towards the square. Go to step 14.

14. Move the *motor* back and forth along the *radial arm*. Repeat step 13 until the *motor arbor* just touches the square at all points. Then go to step 15.

15. Tighten the bottom screws in the front of the *column support*, switching from right to left several times so that you do not force the *radial arm* out of line. Do not overtighten or it will be difficult to raise and lower the *radial arm*.

16. Raise and lower the *radial arm*. If this is difficult, loosen the four screws in the front of the *column support* slightly and try again. Loosen all of these screws the same amount so that you do not force the *radial arm* out of line.

17. Repeat step 16 until movement of the *radial arm* is smooth but firm. Then go to step 18.

18. Lay a framing square on the *front table* with the long edge along the back of the *table* and the short edge alongside the *motor arbor*, as before.

19. Move the framing square toward the *motor arbor* until the arbor and square touch.

20. Move the *motor arbor* back and forth along the *radial arm*. Do not move the square.

21. **If** the *motor arbor* just touches the edge of the square at all points, go to step 22, or

If the *motor arbor* moves away from the edge of the square or tries to “walk” on top of it, go back to step 13 and repeat.

22. Lock the *rip lock*, put the *spacer, fence* and *rear table* back in place, lock the *table clamp*, and go to the next section.

Squaring Blade to Table for Crosscutting

These steps are necessary so that your blade will be perpendicular to the table and cuts will be accurate. If this is not done correctly, your cuts will have a slight bevel angle.

1. Place the *radial arm* in the 0° miter position and lock the miter lock.

2. Place the *blade* on the *arbor shaft* with a **blade collar** on each side. Make sure that the directional arrow is on the outside of the

blade, and the teeth are pointing down at the front side of the blade. (Figure 106)

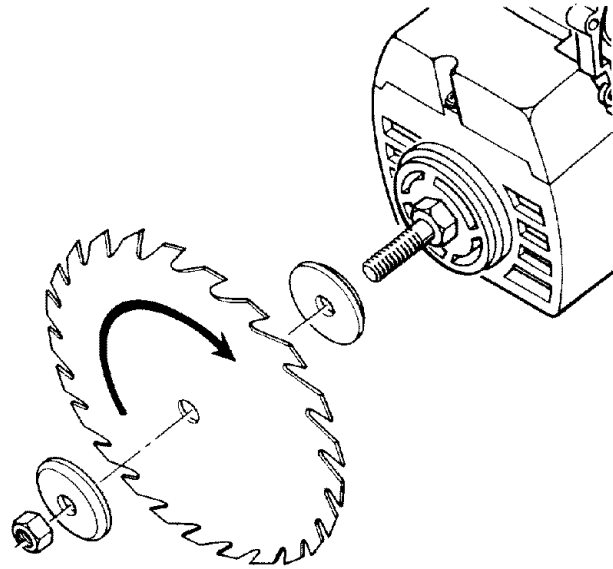

Fig. 106

3. Place the *arbor nut* on the *arbor shaft* and use the *arbor wrenches* to tighten. The *arbor shaft* has left-handed threads, so you will have to turn the nut counterclockwise to tighten. Do not overtighten.

⚠ CAUTION: Overtightening the arbor nuts may cause the blade collars to warp and the blade to wobble while cutting. Use the arbor wrenches to tighten the arbor nuts but do not overtighten.

4. Lock the *table clamps* and *rip lock*.

5. Place the long edge of the framing square on the *table* and the short edge against the *blade*. Make sure that the square is against the blade surface and not the set of a tooth.

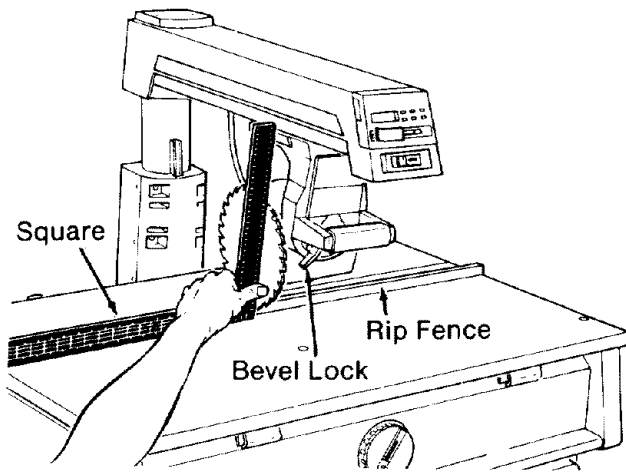

Fig. 107

6. Turn the *blade* with your hand several times and check to see if the square is flush with the *blade*.

7. If the square is flush with the *blade* after each rotation, no change is needed. (Figure 108) Go to the next section, or

If there is a gap between the square and the *blade* after any rotation (Figure 108), go to step 8. **Note:** Saw blades are manufactured to different specifications. Therefore a small gap is permissible on some brands.

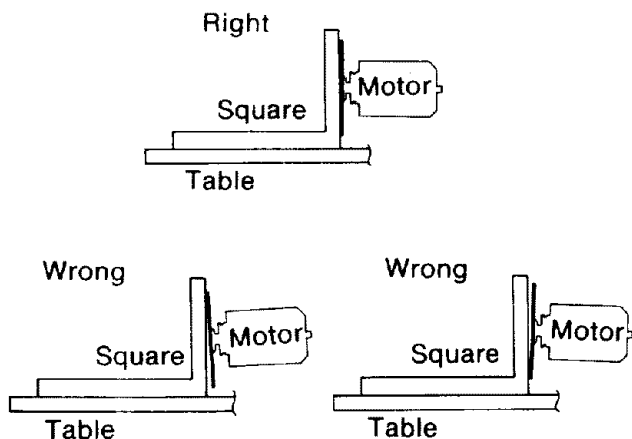

Fig. 108

8. Unlock the *bevel lock*, but do not pull the index pin.

9. Loosen the four screws behind the *yoke* using a 3/16 inch hex-L wrench. (Figure 109)

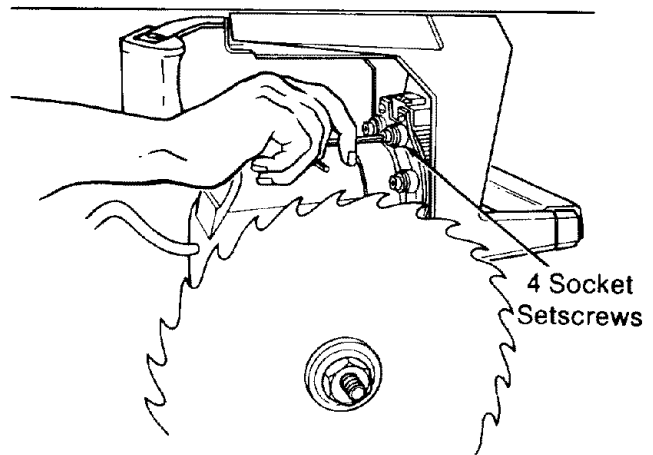

Fig. 109

10. Hold the square in place and move the *motor* slowly until the square is flush with the *blade*.

11. Hold the *saw handle* tightly and lock the *swivel lock*.

12. Check the square to make sure it is still flush with the *blade*.

13. Tighten the four screws under the *yoke* using a 1/8 inch hex-L wrench.

14. Place the framing square with the long edge against **both** the *fence* and the *table*, and the short edge against the *blade* just above the *arbor shaft*, as before. Make sure that the edge of the square is on the *blade* and not on the set of a tooth.

15. Turn the *blade* with your hand several times and check to see if the square is flush with the *blade*.

16. If the square is flush with the *blade* after each rotation, go to the next section, or

If there is a gap between the square and the *blade*, go back to step 6 and repeat.

Squaring Blade to Fence

These steps are done so that your blade will be perpendicular to the fence. This will help reduce the risk of kickback when ripping, and splintering of the workpiece and burning of the kerf when ripping and crosscutting.

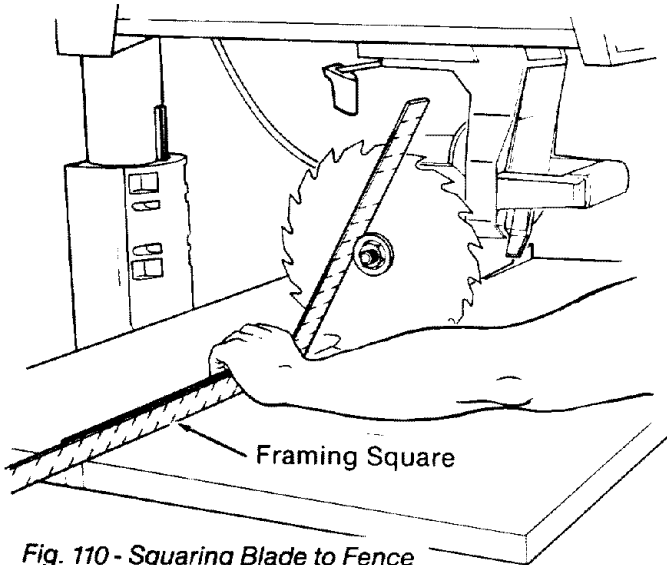

Fig. 110 - Squaring Blade to Fence

1. Put the *radial arm* in the 0° miter position with the *blade* just in front of the *fence*. (Figure 110)
2. Lock the *rip lock*.
3. Place the framing square with the long edge against **both** the *fence* and the *table*, and the short edge against the *blade* just above the *arbor shaft*. Make sure that the edge of the square is on the *blade* and not on the set of a tooth. (Figure 110)
4. Turn the *blade* with your hand several times and check to see if the square is flush with the *blade*.
5. **If** the square is flush with the *blade* after each rotation, no change is needed. (Figure 111) Go to the next section, **or**

If there is a gap between the square and the *blade* after any rotation, go to step 6. (Figure 111)

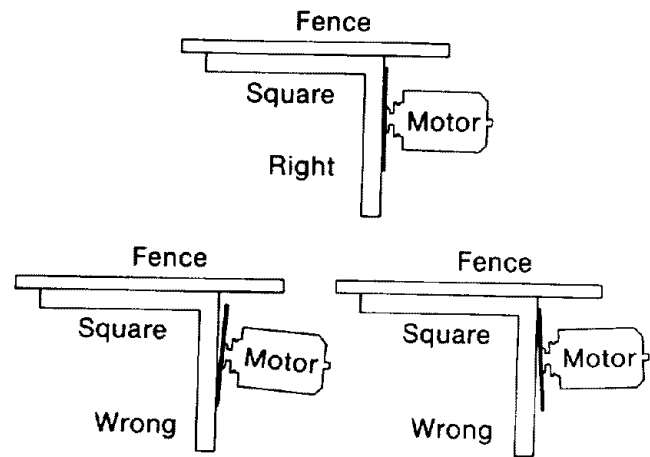

Fig. 111

6. Unlock the *swivel lock*.
7. Loosen the four screws under the *yoke* using a 3/16 inch hex-L wrench and pliers if necessary. (Figure 112)

⚠ WARNING: The hex-L wrench may break when used with pliers to loosen screws. Thrown pieces could hit you in the face and/or eyes. Wear safety goggles when using a hex-L wrench with pliers.

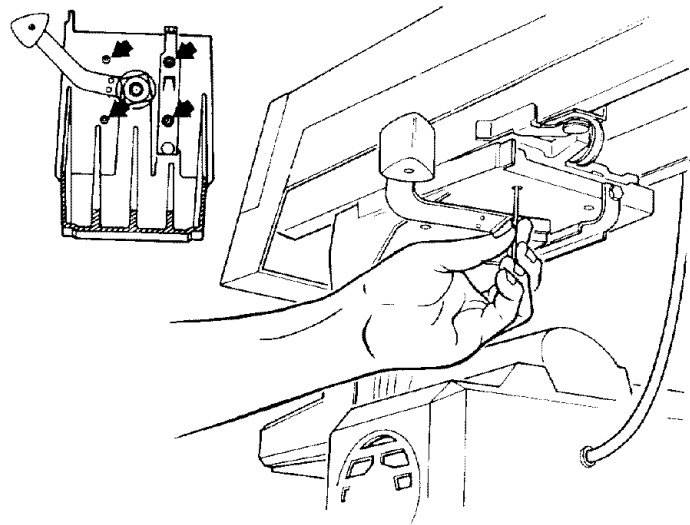

Fig. 112

8. Hold the square in place and turn the *motor* until the square is flush with the *blade*.

9. Hold the *saw handle* tightly and lock the *swivel lock*.

10. Check the square to make sure it is still flush with the *blade*.

11. Tighten the four screws under the *yoke* using a 3/16 inch hex-L wrench.

12. Place the framing square with the long edge against **both** the *fence* and the *table*, and the short edge against the *blade* just above the *arbor shaft*, as before. Make sure that the edge of the square is on the *blade* and not on the set of a tooth.

13. Turn the *blade* with your hand several times and check to see if the square is flush with the *blade*.

14. If the square is flush with the *blade* after each rotation, go to the next section, or

If there is a gap between the square and the *blade*, go back to step 6 and repeat.

Squaring Blade to Table for Ripping

1. Unlock the *swivel lock* and turn the *motor* to the out-rip position with the *motor* between the *blade* and *fence*. (Figure 113)

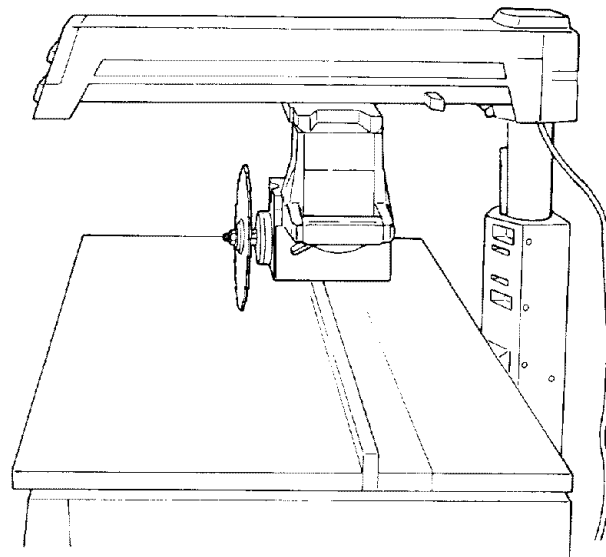

Fig. 113 - Out-rip Position

2. Lock *swivel lock* and *rip lock*.

3. Place the long edge of the framing square on the *table* and the short edge against the *blade* alongside the *arbor shaft*. Make sure the square is against the surface of the *blade* and not on the set of a tooth. (Figure 114)

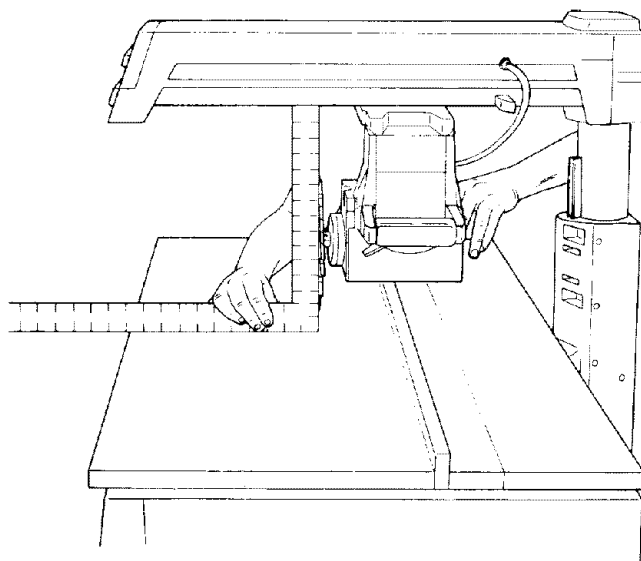

Fig. 114

4. Turn the *blade* with your hand several times and check to see if the square is flush with the *blade*.

5. If the square is flush with the *blade* after each rotation (Figure 115) go to step 11, or

If there is a gap between the square and the *blade* after any rotation (Figure 115), go to step 6.

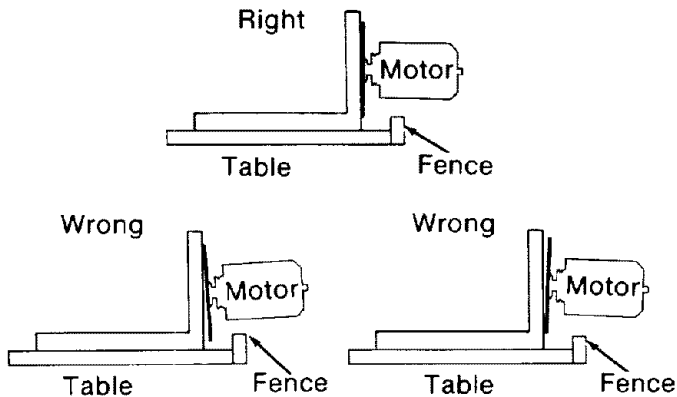

Fig. 115

6. Loosen the hex nut on the *rear carriage bearing*. Use a 9/16 inch wrench to hold the bolt and a 1/2 inch wrench to loosen the nut. (Figure 116)

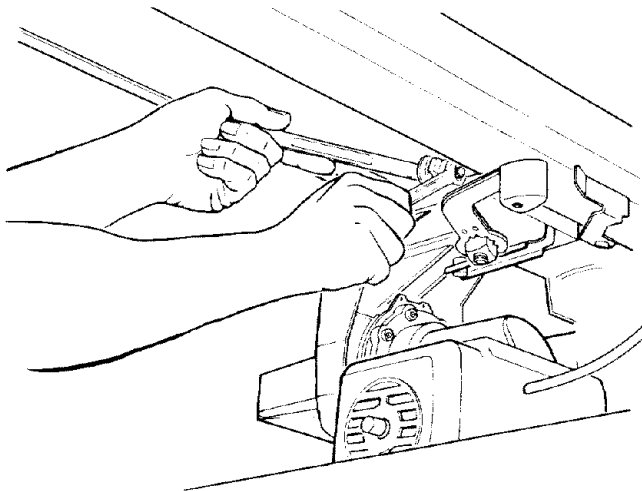

Fig. 116

7. Hold the square in place and use the 9/16 inch wrench to turn the bolt until the square is flush with the *blade*.

8. Hold the bolt firmly, and retighten the hex nut using a 1/2 inch wrench.

9. Turn the *blade* several times and check to see if the square is still flush with the *blade*.

10. If the square is flush with the blade after each rotation, go to step 11, or

If there is a gap between the square and the blade, go back to step 6 and repeat.

11. Unlock the *rip lock* and move the *motor* as far back as it will go.

12. Pinch the *front carriage bearing* with your fingers as tightly as possible while you pull the *motor* forward with the other hand. Try to keep the *carriage bearing* from turning. (Figure 117)

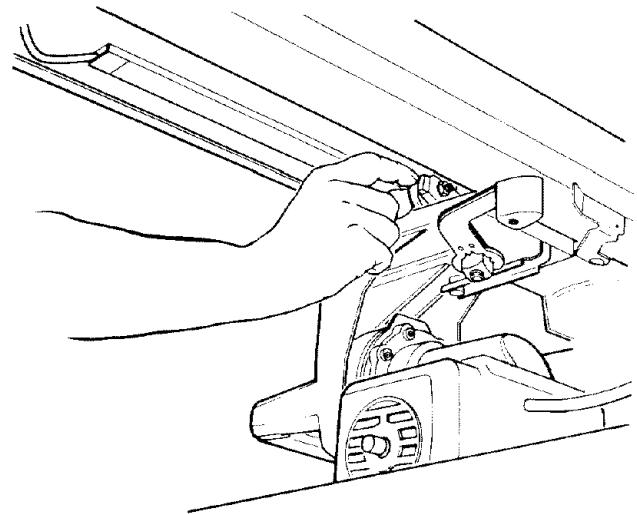

Fig. 117

13. Move the *motor* as far forward as it will go.

14. Pinch the *rear carriage bearing* with your fingers as tightly as possible while you pull the *motor* toward the rear with the other hand. Try to keep the *carriage bearing* from turning.

15. If you can keep either of the *carriage bearings* from turning while the *motor* moves along the *radial arm*, go to step 16, or

If you cannot keep the *carriage bearings* from turning while the motor moves, go to step 22.

16. Wipe the V-shaped groove in each *carriage bearing*, and the track they ride on, with a cloth to remove sawdust and other debris. Oil if necessary.

17. Loosen the hex nut on the *carriage bearing* that was loose. Use a 9/16 inch wrench to hold the bolt and a 1/2 inch wrench to loosen the nut.

18. Turn the bolt using a 9/16 inch wrench until the looseness is gone.

19. Hold the bolt firmly with the 9/16 inch wrench and tighten the hex nut using a 1/2 inch wrench. Do not overtighten.

20. Adjust the other carriage bearing by the same amount so that the *blade* will still be square with the *table*.

21. Repeat steps 11-15 to make sure that the *carriage bearings* are not still loose.

22. Place the long edge of the framing square on the *table* and the short edge against the *blade* just above the *arbor shaft*, as before. Make sure the square is against the surface of the *blade* and not on the set of a tooth.

23. Turn the *blade* with your hand several times and check to see if the square is flush with the *blade*.

24. If the square is flush with the *blade*, go to the next section, or

If there is a gap between the square and the *blade*, go back to step 6 and repeat.

Making Blade Parallel to Table

These steps are done to help prevent the workpiece from being thrown or damaged when the saw is used for edging.

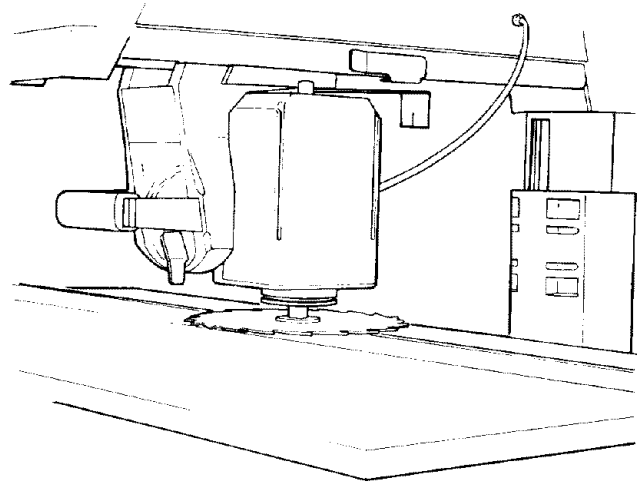

Fig. 119

1. Put the *radial arm* in the 0° miter position.
2. Raise the *radial arm* until the *blade* is 1-1/2 inches above the *front table*.
3. Unlock the *bevel lock*, and turn the *motor* so that the *blade* is parallel to the *table*. (Figure 119)

⚠ CAUTION: The motor is heavy and can swing down quickly. You can be cut or injured if the blade hits you. Hold the motor when you unlock the bevel lock.

4. Lock the *bevel lock*, *rip lock* and *swivel lock*.

5. Place the corner of the framing square against the *fence* so that the long edge is on the *table* under the *blade* and the short edge is sticking up in the air. Make sure that the long edge is perpendicular to the *fence*. (Figure 120)

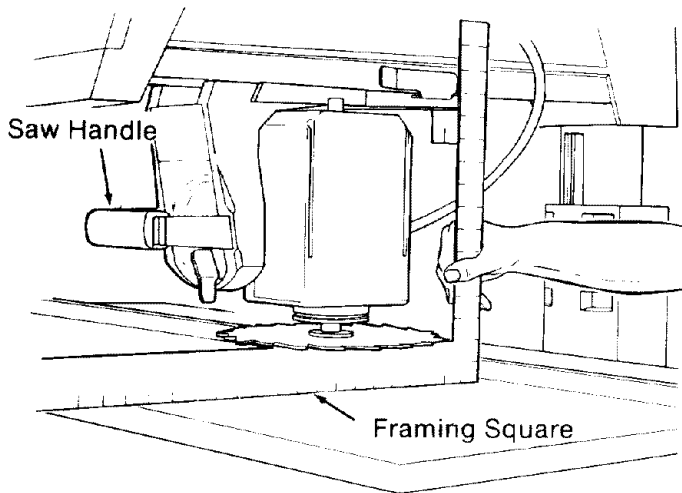

Fig. 120

6. Lower the *radial arm* until the *blade* just rests on the edge of the framing square. Make sure that the square is on the blade and not on the set of a tooth.

7. Turn the *blade* with your hand several times and check to see if the square is flush with the *blade*.

8. If the square is flush with the *blade* after each rotation (Figure 121) go to step 18, or

If there is a gap between the square and the *blade* after any rotation (Figure 121) go to step 9.

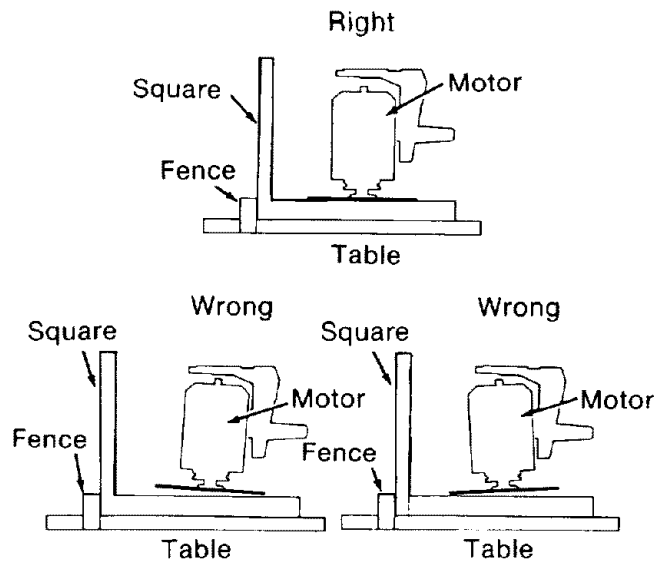

Fig. 121

9. Unlock the *bevel lock*.

10. Loosen the two screws on the back of the *motor support* using a 3/16 inch hex-L wrench and pliers if necessary. (Figure 122)

⚠ WARNING: The hex-L wrench may break when used with pliers to loosen screws. Thrown pieces could hit you in the face and/or eyes. Wear safety goggles when using a hex-L wrench with pliers.

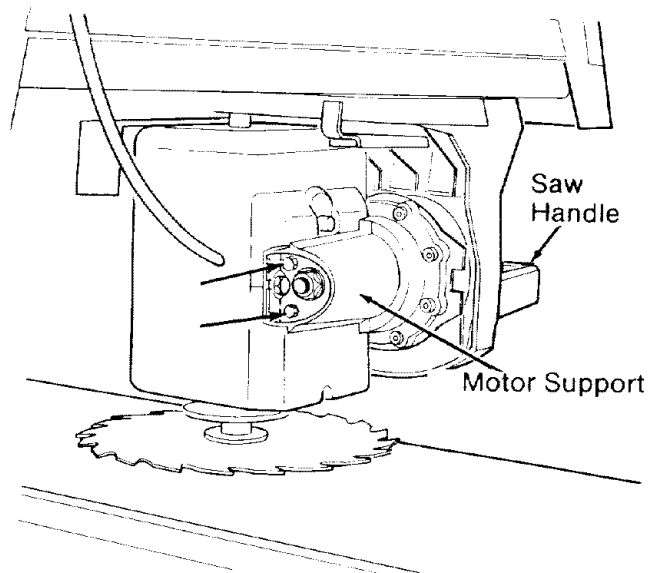

Fig. 122

11. Hold the square in place, and lift or lower the bottom side of the *motor support* until the square is flush with the *blade*.

12. Hold the *motor* firmly and lock the *bevel lock*.

13. Check the square to make sure that it is still flush with the *blade*.

14. Tighten the two screws on the back of the *motor support*.

15. Place the corner of the framing square against the *fence* so that the long edge is on the *table* under the *blade* and the short edge is sticking up in the air, as before. Make sure that the long edge is perpendicular to the *fence*.

16. Turn the *blade* with your hand several times and check to see if the square is flush with the *blade*.

17. If there is a gap between the square and the blade, go back to step 9 and repeat.

Installing Guard / Setting Spreader

The blade guard and the spreader are very important safety features of your saw. The guard covers a large part of the blade and reduces the risk of amputation. The spreader rides in the kerf of the cut wood during ripping, and helps keep the two sides from pinching the blade and causing a kickback.

⚠ WARNING: Fingers, hand, or arm can be cut off from blade contact if the blade guard is not used properly. Always put the blade guard on your saw and adjust it correctly.

⚠ WARNING: Kickback can occur if the spreader is not in line with the blade. You can be injured or killed. Always adjust the spreader and make sure that it is directly in line with the blade.

1. Loosen the *guard clamp screw* until it no longer touches the *metal plate*. (Figure 123)

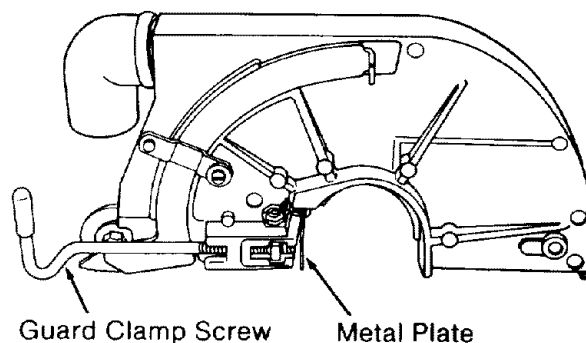

Fig. 123

2. Place the *guard* over the *blade*. You will feel the *guard* fall into place when the ridge on the inside of the *guard* slides into the slot on the *motor*. (Figure 124)

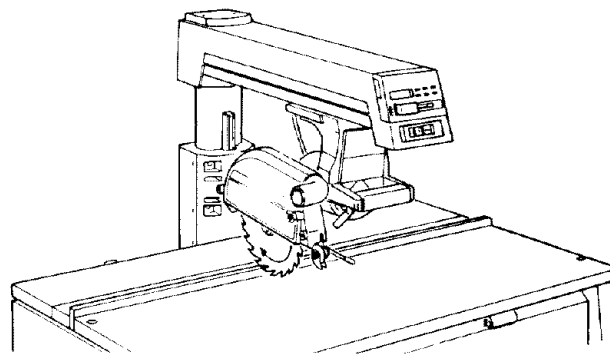

Fig. 124

3. Make sure that the lower edge of the *guard* is parallel to the table. (Figure 124 - above)

4. Tighten the *guard clamp screw*.

5. Unlock the *swivel lock* and turn the *motor* to the in-rip position, with the *blade* between the *motor* and the *fence*. (Figure 125)

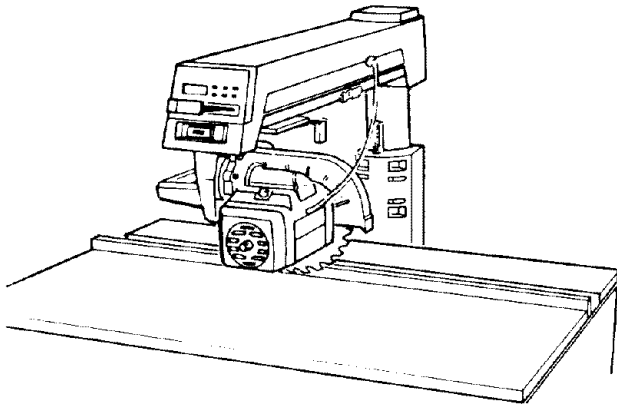

Fig. 125 - In-rip Position

6. Lock the *swivel lock*.

7. Lower the *radial arm* until the *blade* is just above the *table*.

8. Unlock the *rip lock* and move the *motor* back until the *blade* touches the *fence*.

9. Lock the *rip lock*.

10. Loosen the wing screw that holds the *spreader* in place.

11. Lower the *spreader* and *antikickback pawls* until the *spreader* is against the *fence*, and the *pawls* on one side of the *spreader* are on top of the *fence*. (Figure 126)

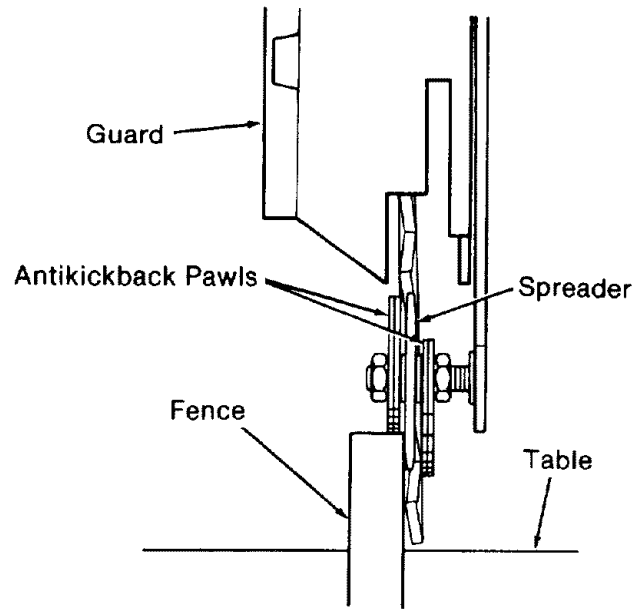

Fig. 126

12. **If** the *spreader* and *blade* both rest against the *fence*, no adjustment is needed. (Figure 127-A) Go to step 17, **or**

If the *spreader* is in front of the *fence* but not touching it (Figure 127-B), go to step 13, **or**

If the *spreader* hits the top of the *fence* (Figure 127-C), go to step 13.

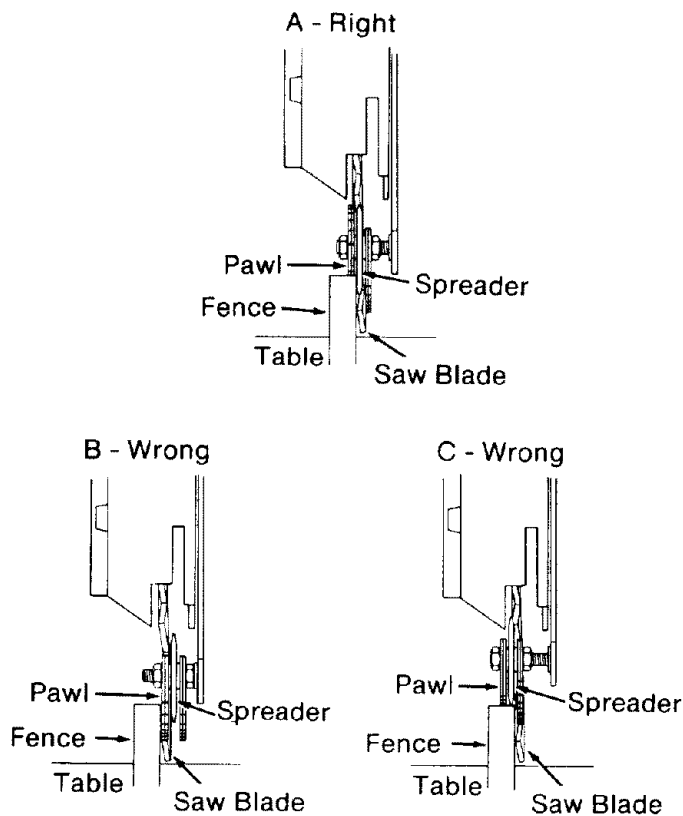

Fig. 127 - A,B,C

13. Loosen both nuts on the *spreader* using a 1/2 inch wrench.

14. Slide the *spreader* with your hand until it is against the *fence* directly behind the *blade*.

15. Tighten both nuts using a 1/2 inch wrench. Do not move the *spreader* as you tighten these nuts.

16. Check the *blade* and *spreader* again to make sure that they are both against the *fence*. If not, go back to step 13 and repeat.

17. Once the *blade* and *spreader* are in line, raise the *spreader* up to the *guard* and tighten the wing screw to hold it in place.

18. Unlock the *rip lock*.

19. Pull the *motor* forward so that the *blade* is away from the *fence* and lock the *rip lock*.

20. Unlock the *swivel lock*.

21. Turn the *motor* to the crosscut position with the blade and arm perpendicular to the fence.

22. Lock the *swivel lock*.

Digital Display

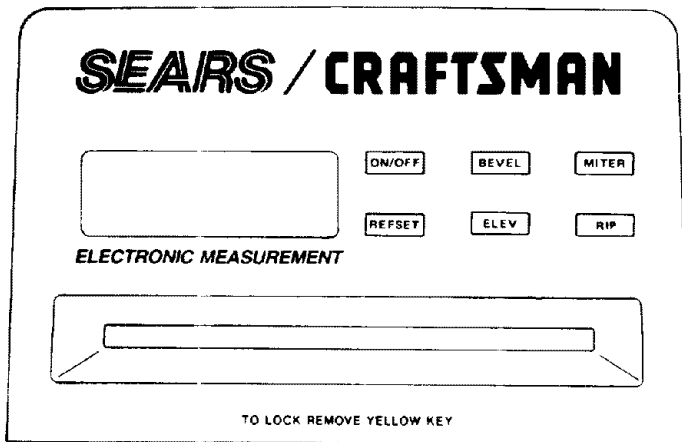

Fig. 128 - Digital Display

Your radial arm saw has a digital display which tells you the position of the blade and arm at the touch of a button. This display helps you position the blade so that your cuts will be accurate.

The following buttons control the digital display:

ON/OFF : This button turns the display on and off. The display runs on battery power, and shuts itself off when no changes in blade or arm position have been made for three minutes. The system continues to track the location of the blade and arm when the display is turned off, and the current position may be displayed at any time.

REF SET: This button is used to set the "0" reference points for the digital display.

BEVEL : This button displays the bevel angle. The "0" display is usually set with the blade perpendicular to the table. A positive display shows the angle the blade has been turned counterclockwise. A negative display shows the angle the blade has been turned clockwise.

ELEV: This button displays the height of the blade. The "0" display is usually set with the blade just touching the table. A positive display shows the distance the blade has been raised above "0". A negative display shows the distance the blade has been lowered below "0".

MITER: This button displays the miter angle. The "0" display is usually set with the arm perpendicular to the fence. A positive display shows the angle the arm has been moved to the right. A negative display shows the angle the arm has been moved to the left.

RIP: This button displays the distance from the fence to the blade in the in-rip and out-rip positions. The "0" display for in-rip is usually set with the blade just touching the fence. The "10.00" display for out-rip is usually set with the blade ten inches from the fence.

The "0" reference points you set will be stored in the memory at all times, whether the display is turned on or off. If an error occurs you will see:

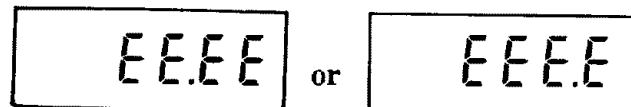

on the display. If this happens, you will need to reset the "0" reference point for the function displaying the error.

If the battery is very weak or dead the display will become faded and hard to read. If this happens, you will need to replace the battery and reset the "0" reference points for all functions.

Installing the Battery

1. Slide the *battery* into the opening behind the digital display with the angled corner on top. (Figure 130)

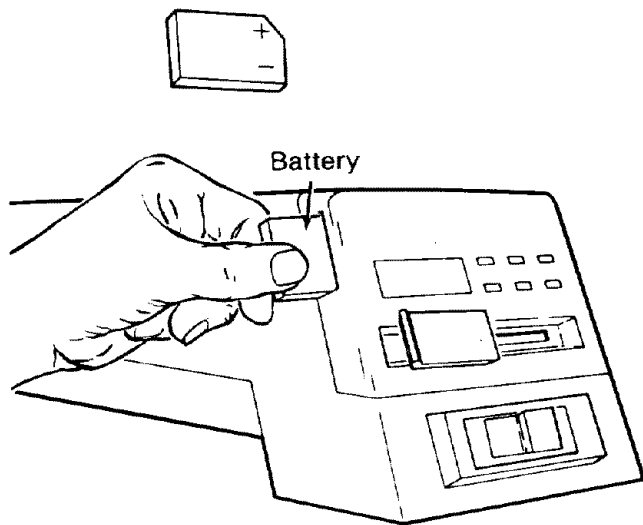

Fig. 129 - Installing the Battery

2. Push the *battery* all the way into this space and slightly downward. It will snap into place, and be held there by a *tab*.

3. If the display says:



a second or two after the *battery* is put in place, go to step 6, or

If the display does not show anything, go to step 4.

4. Remove the *battery*. Put it back in and check the display again, or

Remove the *battery*. Wipe off the battery contacts. Put the *battery* back in and check the display again, or

Remove the *battery*. Replace it with a new one. Check the display again.

5. If there is still no display, contact your nearest Sears store, or

If the display says:



go to step 6.

6. Snap the *battery cover* into place.

7. Push the *ON/OFF button* to turn off the display.

Replacing the Battery

1. Use a screwdriver to pry the *battery cover* off.

2. Push in and slightly upward on the *battery*, then pull out. The *battery* is held in place by a tab that is released when you push in.

3. Replace the *battery* with a 6V, alkaline battery by following the Installing the Battery section.

Aligning Encoders

Miter Encoder

1. Push the *ON/OFF button* to turn the display on.

2. Put the saw in the crosscut position with the *radial arm* perpendicular to the *fence*.

3. Lock the *miter lock*.

4. Push the *MITER button*.

5. Push the *REF SET button*. The display will say:

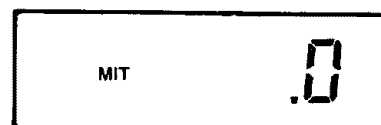

6. Unlock the *miter lock*.

7. Move the *arm* to the right until it snaps into the 45° position.

8. Lock the *miter lock*.

9. The display should say:



10. Unlock the *miter lock*.

11. Move the *arm* to the left until it snaps into the -45° position.

12. Lock the *miter lock*.

13. The display should say:

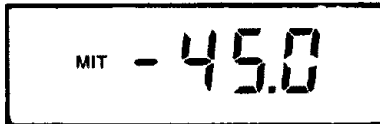

14. **If** the display is correct at all three points, go to the next section, **or**

If the display is not correct at one or more of these points, go to step 15.

15. Unscrew the two mounting screws on the back of the *arm* and take off the *rear arm cover*.

16. Unlock the *miter lock*.

17. Move the *arm* to the right until it snaps into the 45° miter position.

18. Lock the *miter lock*.

19. Loosen the mounting screws on the *miter encoder* until the *encoder* will slide to the right and left. (Figure 130)

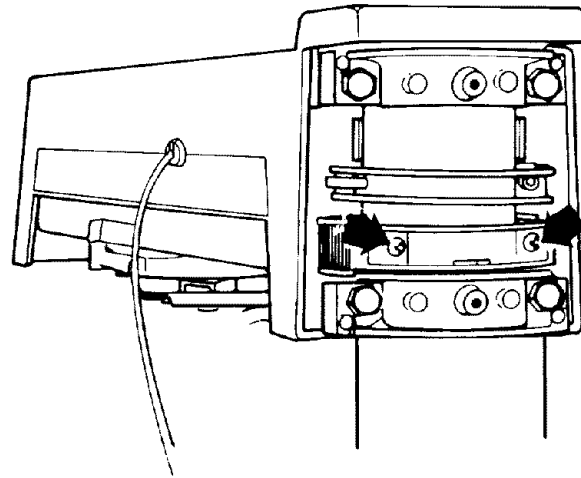

Fig. 130 - Screws for Miter Encoder

20. Slide the *encoder* slightly until the digital display says:



You may need to tap on the *encoder* to move it, but do not force it or hit it hard.

21. Tighten the mounting screws on the *encoder*.

22. Repeat steps 2-13 to make sure you did not move the *encoder* when tightening the mounting screws.

23. **If** the display is still not correct repeat steps 16 - 22 until the *miter encoder* is in the right position, **or**

If the display is correct, put the *rear arm cover* back on the *radial arm*. Go to the next section.

Bevel Encoder

1. Push the *ON/OFF* button to turn the display on.
2. Put the saw in the crosscut position with the *radial arm* perpendicular to the *fence* and the *blade* perpendicular to the *table*.
3. Lock the *bevel lock*.
4. Push the *BEVEL* button.
5. Push the *REF SET* button. The display will say:



6. Unlock the *bevel lock*.
7. Turn the *motor* to the 45° bevel position.

CAUTION: The motor is heavy and can swing down quickly. You can be cut or injured if the blade hits you. Hold the motor when you unlock the bevel lock.

8. Lock the *bevel lock*.
9. The display should say:

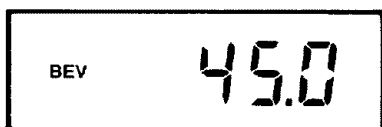

10. Unlock the *bevel lock*.
11. Move the *motor* to the 90° bevel position.
12. Lock the *bevel lock*.
13. The display should say:

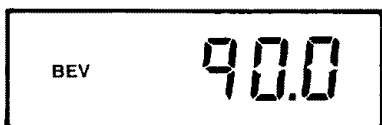

14. If the display is correct at all three points, go to the next section, or

If the display is not correct at one or more of these points, go to step 15.

15. Unlock the *bevel lock*.
16. Move the *motor* to the 45° bevel position.
17. Lock the *bevel lock*.
18. Loosen the two aligning screws on the *bevel encoder* until the *encoder* will slide from right to left. (Figure 131)

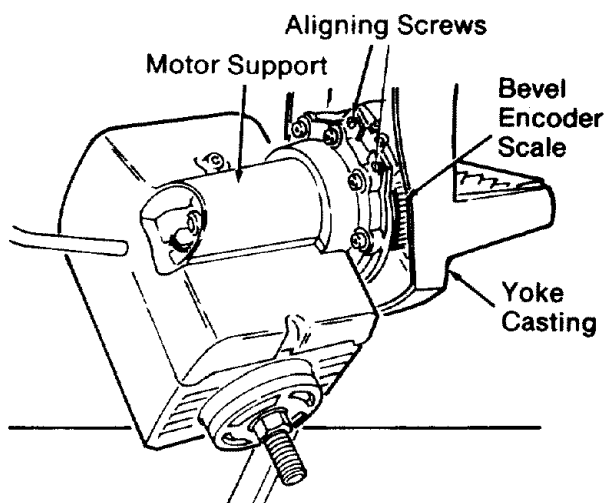
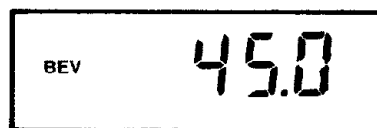

Fig. 131 - Screws for Bevel Encoder

19. Slide the *encoder* slightly until the display says:



You may need to tap on the *encoder* to move it, but do not force it or hit it hard.

20. Tighten the two aligning screws on the *encoder*.
21. Repeat steps 2 - 13 to make sure you did not move the *encoder* when tightening the two screws.

22. If the display is still not correct, repeat steps 15 - 21 until the *bevel encoder* is in the right position, or

If the display is correct, go to the next section.

Setting Zero References

Bevel, Miter and Elevation

The "0" reference points for miter, bevel, and elevation are usually set with the:

- Saw in the crosscut position with the *radial arm* perpendicular to the *fence* (0° miter).
- Blade* perpendicular to the *fence* and *front table* (0° bevel).
- Blade* in front of the *fence* just touching the *front table* (0 inches elevation).

You may set the "0" reference points in this position, or any other position you choose.

1. Put the *blade* in the position you have chosen to be the zero reference point.
2. Push the *MITER* button.
3. Push the *REF SET* button.
4. The display will say:

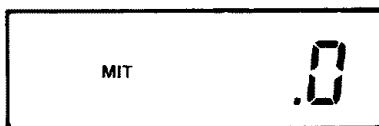

5. Push the *BEVEL* button.
6. Push the *REF SET* button.
7. The display will say:



8. Push the *ELEV* button.

9. Push the *REF SET* button.

10. The display will say:



In-rip Reference

The "0" reference point for in-rip is usually set with the blade just touching the front of the fence.

1. Unlock the *swivel lock*.
2. Turn the *motor* to the in-rip position with the *blade* between the *motor* and the *fence*.
3. Lock the *swivel lock*.
4. Unlock the *table locks* and put the fence between the *front table* and the *spacer*.
5. Lock the *table locks*.
6. Unlock the *rip lock*.
7. Move the *motor* back until the *blade* is just touching the front of the *fence*.
8. Lock the *rip lock*.
9. Push the *RIP* button.
10. If the display shows the RIP function, go to step 11, or
If the display shows the O-RIP function, push the *RIP* button again. Then go to step 11.
11. Push the *REF SET* button.
12. If the display says:



go to the next section, or

If the display says:



push the *REF SET* button again. Then go to the next section.

Out-rip Reference

The "0" reference point for out-rip is usually set with the blade ten inches from the fence.

1. Unlock the *swivel lock*.
2. Turn the *motor* to the out-rip position with the *motor* between the *blade* and the *fence*.
3. Lock the *swivel lock*.
4. Unlock the *table locks* and move the *fence* behind the *spacer* and *rear table*. (Figure 146)
5. Lock the *table locks*.
6. Unlock the *rip lock*.
7. Move the *motor* until the *blade* is 10 inches in front of the *fence*. Use a framing square, ruler or tape measure to measure this distance. (Figure 132)

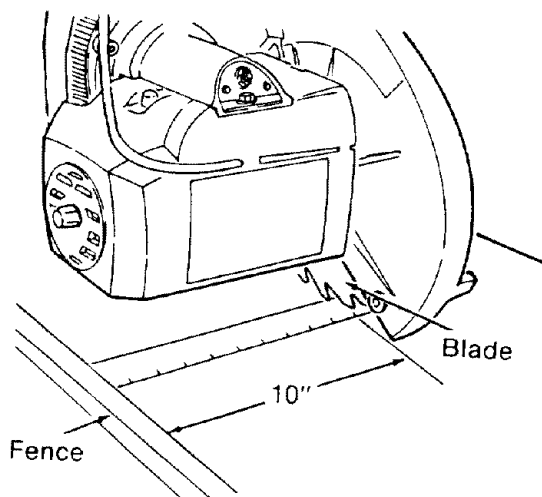

Fig. 132 - Out-Rip Reference

8. Lock the *rip lock*.

9. Push the RIP button.

10. If the display shows the O-RIP function, go to step 11, or

If the display shows the RIP function, push the RIP button again. Then go to step 11.

11. Push the *REF SET* button.

12. If the display says:

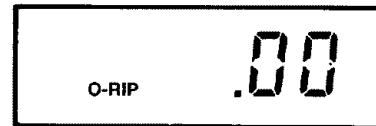

13. Push the *REF SET* button again.

The display will say:

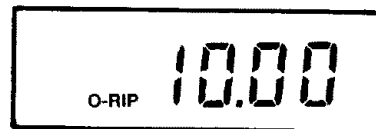

Electrical Connections

Motor Specifications

The AC motor used in this saw is a capacitor-start, non-reversible type having the following specifications:

Rated H.P.	1.5
Maximum Developed H.P.	2.75
Voltage	120/240
Amperes	12/6
Hertz (cycles)	60
Phase	Single
RPM	3450
Rotation of Arbor Shaft	Clockwise

Power Supply

▲ WARNING: Your saw is wired at the factory for 120V operation. Connect to a 120V, 15-AMP, branch circuit and use a 15-AMP, time delay fuse or circuit breaker. Failure to connect in this way can result in injury from shock or fire.

If the motor is rewired for 240V operation, connect to a circuit protected by 15-AMP, dual element time delay fuse or circuit breaker.

Your saw must be properly grounded. Not all outlets are properly grounded. If you are not sure that your outlet is properly grounded, have it checked by a qualified electrician.

▲ WARNING: If not properly grounded this power tool can cause electrical shock, particularly when used in damp locations.

▲ WARNING: If an electrical shock occurs, your reaction to the shock may bring your hands into contact with the blade.

▲ WARNING: To avoid shock or fire, if power cord is worn, cut, or damaged in any way have it replaced immediately.

If your unit is for use on less than 120V it has a plug that looks like below. (Figure 133)

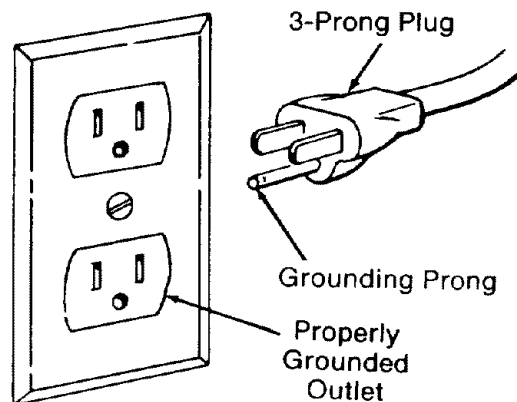

Fig. 133 - Plug for Less Than 150V

This power tool is equipped with a 3-conductor cord and grounding type plug which has a grounding prong listed by Underwriters' Laboratories. The ground conductor has a green jacket and is attached to the tool housing at one end and to the ground prong in the attachment plug at the other end.

This plug requires a mating 3-conductor grounded type outlet as shown above. If you have an outlet that is of the two prong type, it is recommended that you have a qualified electrician replace it with a properly grounded three prong outlet.

⚠ WARNING: To maintain proper tool grounding, whenever the outlet you are planning to use for this power tool is of the two prong type do not remove or alter the grounding prong in any manner.

An adapter is available for connecting plug to 2-prong receptacles. The green grounding lead extending from the adapter must be connected to a permanent ground such as to a properly grounded outlet box. (Figure 134)

Extension Cords

The use of any extension cord will cause some loss of power. Use the following table to determine the minimum wire size (A.W.G.) extension cord. Use only 3-wire extension cords which have 3-prong grounding type plugs and 3-pole receptacles which accept the tool's plug.

Length of Conductor	Wire sizes Required (American Wire Gage No.)	
	120V Lines	240V Lines
0 - 25 feet	No.14	No. 16
26 - 50 feet	No.12	No. 14
51 - 100 feet	No. 8	No. 12

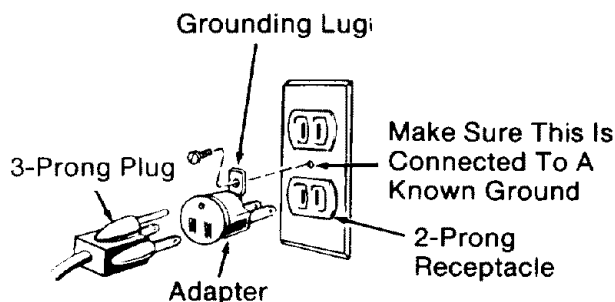

Fig. 134 - Adapter for 2-Prong Receptacles

For circuits that are farther away from electrical circuit box, the wire size must be increased proportionately in order to deliver ample voltage to the saw motor.

⚠ WARNING: The adapter illustrated is for use only if you already have a properly grounded 2-prong receptacle.

Crosscutting

Crosscutting is used to cut a workpiece to length. The workpiece is held against the fence. The saw blade is pulled through the workpiece. Cuts are usually made across the grain of the workpiece.

Types of Crosscuts

The basic types of crosscuts are shown below. Notice the hand and body position in each.

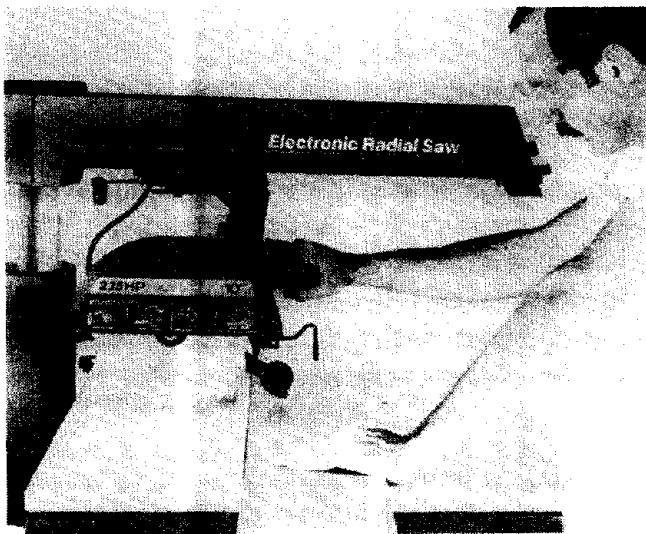

Fig. 135 - Straight Crosscut

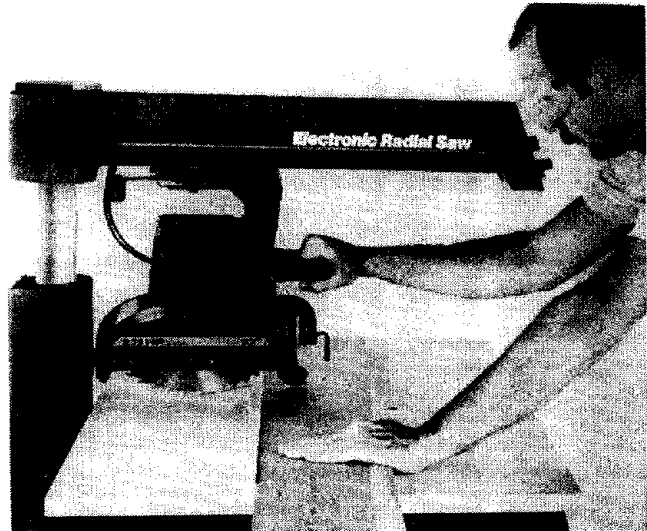

Fig. 137 - Bevel Crosscut



Fig. 138 - Compound Crosscut



Fig. 136 - Miter Crosscut

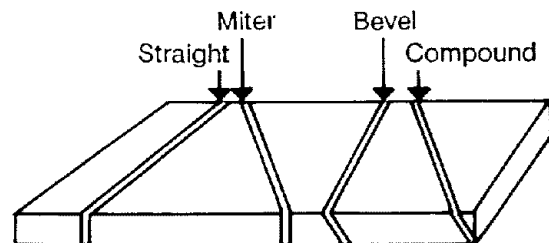

Fig. 139 - Basic Crosscuts

Safety Information for Crosscutting

Read and follow the safety information below before making any type of crosscut.

WARNING

1. Set guard and anti-kickback pawls to proper height to serve as a partial barrier.

2. The saw blade can throw the workpiece over the fence if the blade is pushed backwards into workpiece. You or others can be hit and injured by the thrown workpiece. Start a crosscut with the blade in its rearmost position.

3. If the blade is pulled through the workpiece beyond the middle of the blade, it can:

- pick up and throw the cut-off section of the workpiece which could hit and injure you or others in the area, or;
- lift or move the held-down section of the workpiece and pull your hand into the blade as the blade is returned. Pull the saw blade through the workpiece to the distance shown below.



Fig. 140 - Blade Distance to Complete Crosscut

4. Fingers or hand can slip into the saw blade as you make a crosscut. Fingers, hand or arm can be cut off. Keep the hand holding the workpiece at least 8 inches to the side of the workpiece, out of the path of the saw blade. Keep hand holding the workpiece in view at all times.

5. The blade can come completely off table edge beyond the 30° left miter position. Fingers, hands, arms or legs can be cut off. Use the right miter position whenever possible to make miter crosscuts.

6. The blade continues to turn for about 12 seconds after the saw is turned off. Wait for the blade to stop before reaching for the workpiece.

7. If length stops are used on the cut-off end of workpiece, the cut-off end can be thrown by the blade. The workpiece could hit and injure you or others in the area. Do not use a length stop on the cut-off end of the workpiece. Use a length stop only on the end of the workpiece which is held down.

8. Holding on to or touching the cut off end of the workpiece while the saw blade is still turning can cause the workpiece to pinch the blade. The workpiece can be thrown and hit and injure you or others in the area. Do not touch, hold on to, push, or grab the cut-off piece of the workpiece while the power is on or the saw blade is turning.

9. The saw can throw the workpiece, workpiece chips or pieces of the blade violently. You can be blinded. Wear safety goggles.

10. The workpiece cannot be controlled or held stable enough to do free hand cutting. The workpiece can be thrown or slip and pull fingers and hand into the saw blade. Fingers or hand can be cut off. Set the radial arm to the desired cutting angle. Keep workpiece flat on table and solidly against the fence.

11. Saw parts loosen and wear with use. You or others can be injured. Keep all parts tight and in working order.

12. The fence must be of at least equal height to the workpiece or else the workpiece can be lifted or thrown and hit and injure you or others in the area. See Cutting Accessories section for instructions to make a fence.

13. The blade will try to pull itself through the workpiece. Be prepared to hold the saw handle back to keep the saw blade from coming toward you.

14. Lock rip lock after every crosscut, or else the blade will suddenly come toward you when you lower it to make a crosscut.

15. Whenever the blade is turning, keep one hand on the saw handle to keep the saw blade from coming toward you.

16. Cutting more than one workpiece at a time can cause you to lose control of the workpieces, which can be thrown and hit and injure you or others in the area. Cut only one workpiece at a time. Do not stack or lay workpieces edge to edge.

Blade Guard, Anti-Kickback Pawls and Spreader

The blade guard, anti-kickback pawls and spreader are designed to reduce or eliminate the risk of injury from contact with the upper half of the blade and the leading edge of the blade when:

- the guard is in the horizontal position and;
- the pawls and spreader are set to clear the top of the fence and workpiece by about 1/8 inch.

The Blade Guard:

- provides protection from contact with the upper half of the blade;
- helps keep the workpiece from jamming in the guard and;
- helps catch or deflect workpiece chips or pieces of the blade.

The Anti-kickback Bar, Pawls and Spreader:

- serve as a partial barrier to provide protection from contact with the leading edge of the blade.

 **WARNING:** To reduce the risk of contact with the upper half of the blade and keep the workpiece from jamming in the guard, set the blade guard in the horizontal position, Fig. 144.

Crosscutting Checklist

Use the following checklist at the beginning of each new cutting period to reduce the risk of an accident.

Crosscut Checklist

Yellow key removed from red switch.

Saw unplugged and switch off.

No play in the carriage bearings, motor support or column. See Alignment of the Blade section for instructions.

Arm slopes to the rear and table level side to side.

Arbor nut snug.

Blade sharp.

Fence secure, solid (knot free) and in good condition.

Fence in correct table position.

Workpiece does not extend above the top of the fence.

All saw parts are tight and working.

Saw blade in desired crosscut position and behind the fence.

Blade guard horizontal.

Anti-kickback pawls and spreader set to clear top of fence and/or workpiece by about 1/8 inch.

Swivel, rip, miter, bevel and table locks locked.

Read and follow instructions for the type of crosscut you want to do.

Cutting Table and Fence Kerfs

You will need to cut a new table kerf (shallow cut) and fence kerf (slot left in the fence from sawing through it with the blade), each time a new cutting angle is used. The table kerf lets the blade cut all the way through a workpiece.

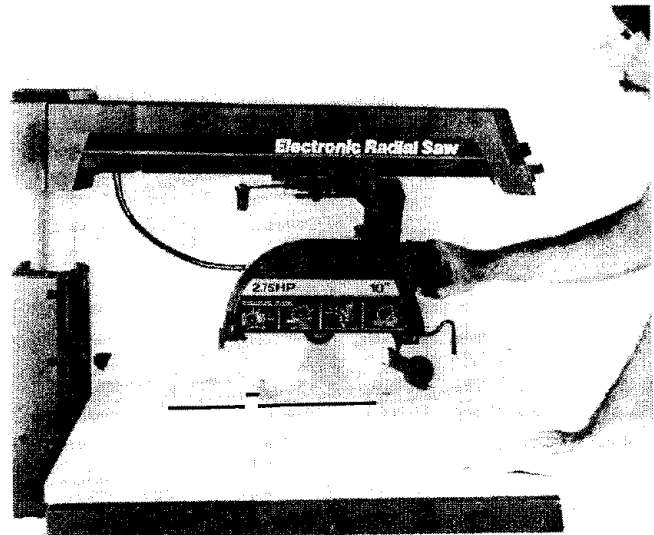

Fig. 141 - Table and Fence Kerfs

Note: To extend the life of your table top, you can make an additional table top. See Helpful Hints section.

Making Table and Fence Kerfs for Crosscutting

To make a crosscut kerf in your table and fence:

1. Put your fence between the front table and spacer board. Lock the table locks.
2. Push the saw to the rearmost position, behind the fence.
3. Lock rip lock.

⚠ WARNING: The saw blade will suddenly come toward you when lowered into the table if the rip lock is unlocked. Fingers and hand can be cut off. Lock the rip lock before and after each crosscut.

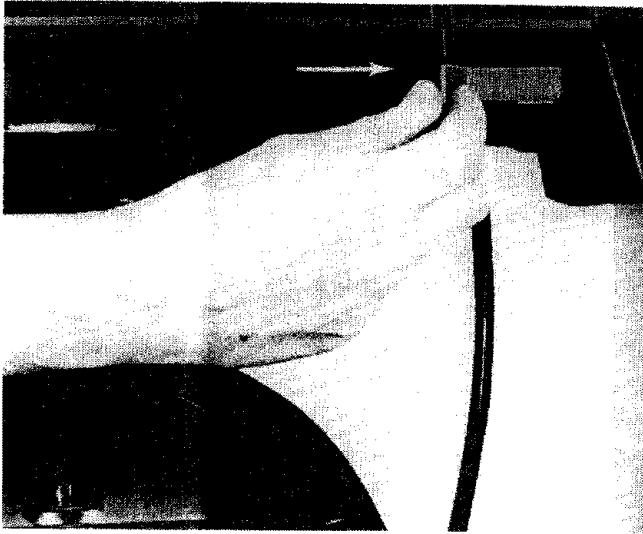

Fig. 142 - Locked Position for Rip Lock

4. Lower the radial arm until the blade almost touches the table top.
5. Plug the saw into a grounded outlet. Check Electrical Connections section of manual if you are not sure the outlet is grounded.
6. Wear safety goggles labeled ANSI Z87.1 on the package.

⚠ WARNING: The saw can throw the workpiece, workpiece chips or pieces of the blade violently. You can be blinded. Wear safety goggles.

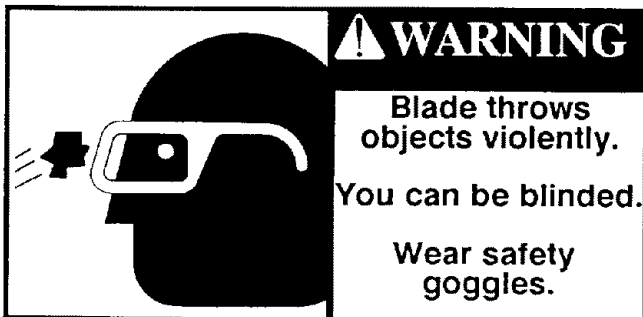

Fig. 143 - Safety Goggles Safety Sign

7. Insert yellow key into the red switch.

8. Grasp saw handle and hold your forearm in line with the saw handle as shown below.

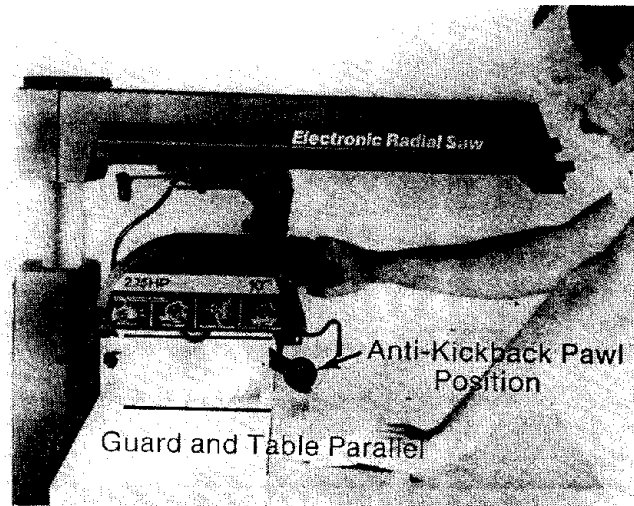

Fig. 144 - Crosscut Blade Guard and Body Position

⚠ WARNING: Saw blade can suddenly come toward you when turned on. Fingers, hand or arm can be cut off. Keep one hand on the saw handle at all times.

9. Turn the saw on.
10. Lower the saw arm slowly until the blade touches the table.
11. Turn the handwheel another 1/2 turn more. This will let you make a 1/32 to 1/16 inch kerf in the table.
12. Unlock rip lock.
13. Pull the saw blade forward through the fence and along the table as far as it will go.
14. Return the saw blade to its rearmost position behind the fence.
15. Turn the saw off, but do not let go of the saw handle.
16. Wait for blade to stop turning.
17. Lock rip lock.
18. Remove yellow key from red switch.

Making Crosscuts

The following section contains safety information and instructions for making crosscuts. Anyone who uses your saw should read and follow these steps.

⚠ WARNING: The blade guard must be horizontal to provide protection from contact with the upper half of the blade and avoid the workpiece being jammed in the blade. Set the blade guard in the horizontal position. Fig. 144.

⚠ DANGER: The anti-kickback pawls serve as a barrier for the leading edge or the blade. Set the anti-kickback pawls to clear the top of the fence and workpiece by about 1/8 inch.

⚠ WARNING: The fence must be at least equal height or higher than the workpiece you are going to cut or else the workpiece can be thrown and injure you or others in the area. Install a fence of at least equal height to the workpiece.

1. Put your fence in position A as shown and lock the table locks.

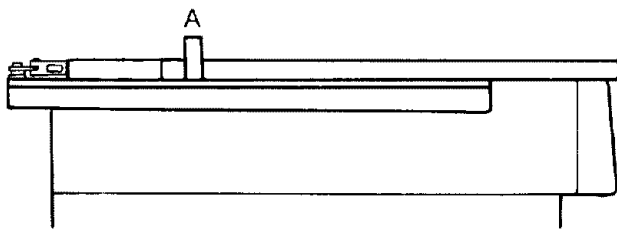

Fig. 145 - Fence Position for Crosscut

2. Push the saw to the rearmost position, behind the fence.

3. Lower the blade into but not touching the table kerf.

4. Adjust the height of the anti-kickback pawls to clear top of fence and workpiece by about 1/8 inch. The pawls and spreader help provide protection from the leading edge of blade.

5. Plug saw into grounded outlet.

6. Put on safety goggles.

7. Place the workpiece against the fence.

8. Unlock rip lock.

9. Grasp the saw handle while holding your forearm in a straight line with the saw handle.

⚠ WARNING: The saw blade tries to pull itself through the workpiece. Be prepared to hold saw handle back to keep the saw blade from coming toward you. Keep one hand on the saw handle at all times.

⚠ WARNING: If the saw blade is pulled through the workpiece beyond the middle of the saw blade, it can:

- pick up and throw the cut-off section of the workpiece which could hit and injure you or others in the area, or;
- lift or move the held-down section of the workpiece and draw your hand into the blade as the blade is returned.

Pull the saw blade through the workpiece to the distance shown below.



Fig. 146 - Distance Needed to Complete Crosscut

10. Insert yellow key into red switch.

11. Turn saw on.

⚠ WARNING: Saw blade can be pulled into or over fingers or hand. Fingers or hand can be cut off. Keep hand holding the workpiece at least 8 inches to the left of, and out of the path of the saw blade. Keep hand in view at all times.



Fig. 147 - Hand Placement for Crosscuts

12. Support and hold the workpiece down and against the fence firmly with your left hand.

13. Pull blade through fence and workpiece just enough to complete the cut. Fig. 146.

14. Return saw to its rearmost position and continue to hold the saw handle.

15. Turn saw off.

16. Wait for the blade to stop turning.

17. Remove yellow key from red switch.

Repetitive Crosscuts

To make repetitive crosscuts:

1. Use two pieces of 1 inch by 2 by 2 inch lumber.

2. Use a C clamp to clamp one piece on each side of the lower right edge of the radial arm.

3. Clamp pieces of lumber at the distance necessary to complete the crosscut.

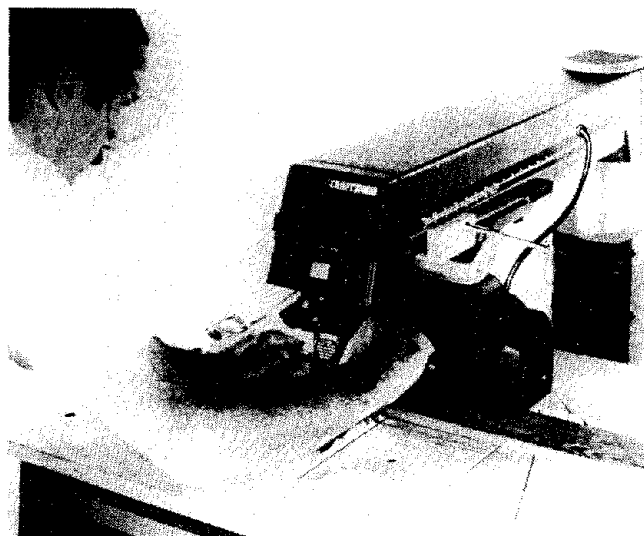

Fig. 148

Ripping

Ripping is used to change the width of the workpiece by sawing along its length. The workpiece is fed into the saw blade. The fence is used as a guide. Rip cuts are usually made with the grain of the workpiece.

Saw Positions for Ripping

There are two saw blade positions for making rip cuts: in-rip and out-rip.

In in-rip position, motor is toward the front of the table, and blade is toward the fence.

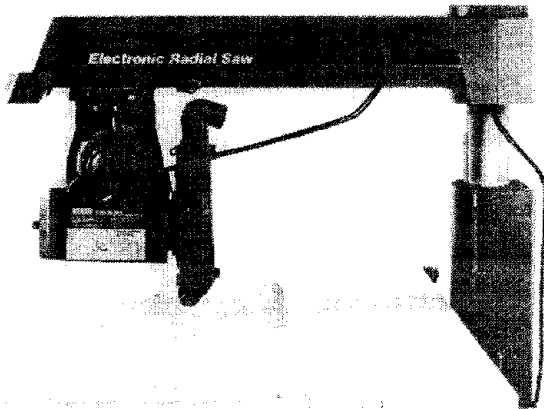

Fig. 149 In-Rip Saw Position

In out-rip position, motor is toward fence and the blade is toward the front of the table.

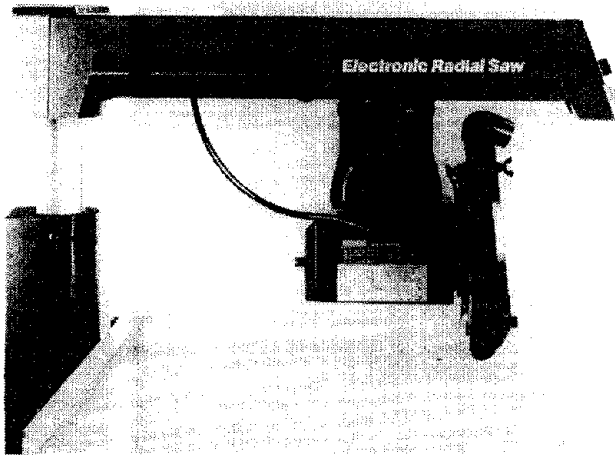

Fig. 150 Out-Rip Saw Position (Infeed End)

⚠ WARNING: Stand only at infeed end of saw. Feed workpiece only into infeed end of saw as shown above.

When to Use In-Rip or Out-Rip

The in-rip saw position provides better visibility of both the workpiece and your hands than does the out-rip saw position. The only time you should use the out-rip saw position is when the workpiece is 14 inches or wider. Use the in-rip position for all workpieces less than 14 inches wide.

Workpiece Positioning for Ripping

Always set up the saw blade so the widest part of the workpiece is between the blade and the fence. For example, if you want to take 1 inch off an 11 inch wide workpiece, set the saw blade 10 inches from the fence. Do not rip 1 inch off an 11 inch workpiece by setting the saw blade 1 inch from the fence.

⚠ WARNING: If the blade is set between 2 inches and 6 inches from the fence, hands will be brought too close to the blade. Fingers and hand can be cut off. Use a push stick.

For example, if the workpiece is 7 inches wide and you want to cut 1 inch off the workpiece, place the saw blade 6 inches from the fence and use a push stick. Use a push stick when the distance between the saw blade and fence is between 2 inches and 6 inches. See Cutting Accessories section on how to make and use a push stick.

⚠ WARNING: If the blade is set between 1/2 inch and 2 inches from the fence, hands will be brought too close to the blade. Fingers/hand can be cut off. Use an auxiliary fence/push block.

For example, if the workpiece is 3 inches wide and you want to cut 1 inch off the workpiece, place the saw blade 2 inches from the fence and use a push block and auxiliary fence. See Cutting Accessories section.

Safety Information for Ripping

Read and follow the safety information below before making any type of rip cut.

DANGER

1. Kickback can happen when the saw blade is pinched or bound by the workpiece. This creates force in the opposite direction to which the workpiece is being fed. The teeth of the blade grab and throw the workpiece violently back out of the saw.

Kickback can happen when:

Anti-kickback pawls/spreader are not used or not correctly adjusted.

Spreader is not in line with the blade.

Blade is not parallel to the rip fence.

Edge of workpiece is not in contact with the rip fence or not straight.

Workpiece is twisted or warped and rocks on the table top.

Edge of workpiece is not completely against the rip fence, leaving gaps between the fence and workpiece edge.

Workpiece is released before being pushed completely past the saw blade.

Feeding pressure is put on the section of the workpiece farthest from the fence.

2. One of the most common and the most dangerous mistakes people make is to reach for the workpiece at the out-feed side of the saw. **DON'T!** The workpiece could kickback as you reach for, touch or try to pull the workpiece through the blade. You can lose your fingers, hand, or arm. The blade guard does **NOT** provide complete protection at outfeed end of the saw. Do not reach for the workpiece at outfeed end of the saw. Fingers, hand or arm can be cut off. Follow instructions for ripping.



Fig. 151 Kickback, Blade Contact Safety Sign

3. The workpiece can also kickback violently toward you during a rip cut. You can be hit hard enough to cause broken bones and/or internal injury. Keep blade guard, anti-kickback pawls and spreader in place and adjusted. Apply feed pressure to the section of the workpiece next to the fence. Do not apply feed pressure on the section of the workpiece away from the fence. Stand out of the path of the workpiece.

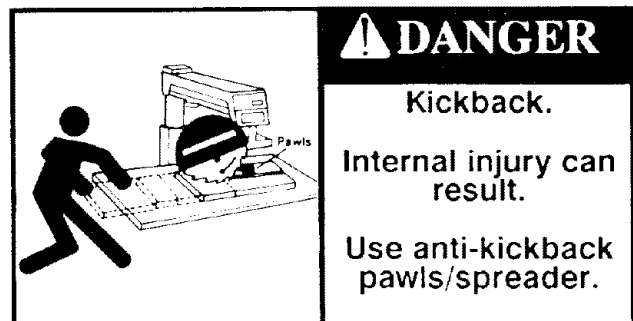

Fig. 152 Kickback, Thrown Workpiece Safety Sign

4. Non-thru cuts increase the chance of kickback because the anti-kickback pawls cannot always grab the irregular workpiece surface. Use a featherboard. See Cutting Accessories section on how to make and use a featherboard.

5. The workpiece can snag or hang up on a fence with a kerf in it. The workpiece can be thrown or pinch the blade, causing kickback. Use solid fences when making rip cuts.

6. Wood cut with the grain can spring the kerf closed, bind the blade, and cause a kickback. Adjust spreader to ride in the kerf and prevent the kerf from closing on saw blade.

7. Composition materials, like particle boards and plastics, may be cut on the saw. Because these materials often have a harder and more slippery surface than wood, the anti-kickback pawls may not stop a kickback. Place finished side of workpiece down, roughest side of workpiece up. Make anti-kickback pawls and spreader adjustments. Stand out of the path of workpiece.

2. The workpiece can be grabbed by the saw blade and take off like a missile. Anyone standing in the path of the workpiece can be killed.

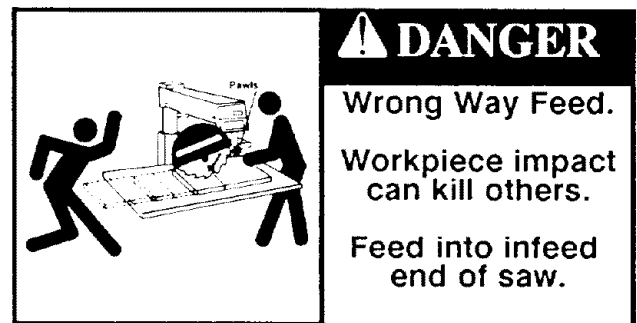
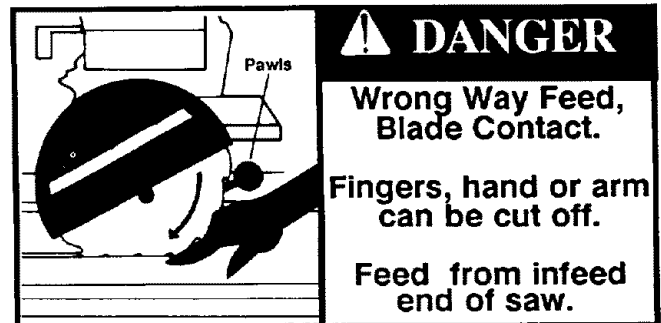

Fig. 153 Wrong Way Feed Safety Signs

Always feed the workpiece against the direction of rotation of the blade, at the infeed end of the blade.

⚠ DANGER: Wrong Way Feed

Wrong way feed is feeding the workpiece into the end of the blade with pawls, the outfeed end. (Fig. 154) There are two things that can happen if you feed the workpiece into the outfeed end of the saw blade:

1. The workpiece can be grabbed by the blade and pull your hands into the blade before you can let go or pull back. Fingers, hands or arms can be cut off.

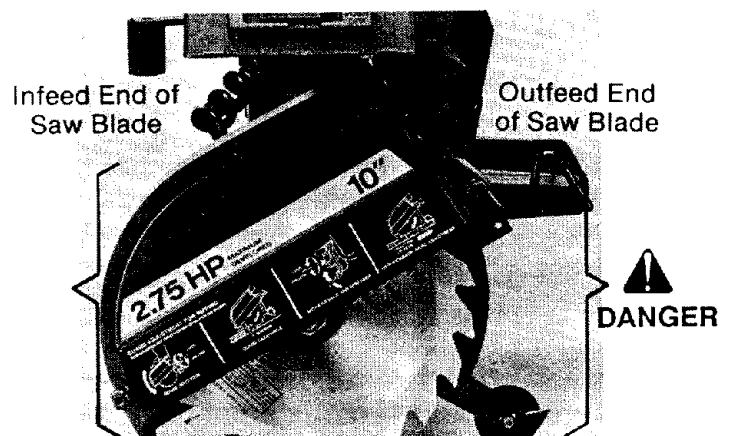

Fig. 154 Infeed and Outfeed Ends of Saw Blade

Blade Guard, Anti-kickback Pawls and Spreader

The blade guard, anti-kickback pawls and workpiece spreader are designed to reduce or eliminate the risk of injury from blade contact, workpiece kickback and wrong way feed.

The Blade Guard:

- serves as a partial barrier to help keep hands from contacting the blade at the infeed end of the saw blade.
- helps keep the workpiece from lifting or fluttering during ripping.
- helps catch or deflect workpiece chips or pieces of the blade.

The Anti-Kickback Pawls :

- help reduce kickback by grabbing into and holding the workpiece.
- act as a barrier to provide some protection from blade contact.

The Spreader:

- helps keep the kerf of the workpiece open, which helps prevent the blade from being pinched and causing workpiece kickback.
- when correctly set, helps reduce or eliminate the chance of wrong way feed because it blocks the workpiece from contacting the saw blade.

 **WARNING: The anti-kickback pawls and spreader adjustments must be made each time a different thickness workpiece is cut to reduce or eliminate kickback.**

Rip Cutting Checklist

Use the following rip cutting checklist at the beginning of each new cutting period to reduce the risk of an accident.

Rip Cutting Checklist

Yellow key removed from switch.

Saw unplugged and switch off.

No play in the carriage, yoke or column.

Arm slopes to the rear and table level side to side.

Arbor nut snug.

Blade sharp.

Fence secure, solid (knot free), no kerfs.

Fence in correct rip position.

Saw blade desired distance from the fence for cut.

Swivel, bevel, rip, miter and table locks locked.

Blade guard, anti-kickback pawls and spreader adjusted.

Use push stick if cutting between 2 and 6 inches off workpiece.

Use push block if cutting between 1/2 and 2 inches off workpiece.

Use featherboard if making a non-through cut and when needed on through cuts.

Read and follow instructions for the type of rip cut you want to make.

Making a Rip Cut Table Kerf

You will need to make a table kerf before a rip cut can be made. Every time you move the blade a new distance from the fence, you will need to make a new kerf.

1. Put saw in desired rip position and lock the saw arm in the 0° position.
2. Lock rip, swivel, miter, bevel and table locks.
3. Adjust saw arm with handwheel until the saw blade almost touches the table top.
4. Plug the saw into a grounded outlet.
5. Put on safety goggles.
6. Insert the yellow key in the red switch.
7. Turn saw on.
8. Lower saw blade until blade touches the table.
9. Turn the handwheel about 1 full turn more. This will make a 1/16 to 1/8 inch kerf in the table.

⚠ WARNING: For workpieces 1/4 inch thick or less, make the rip kerf at least 1/8 inch deep to keep the saw blade from rising up on top of workpieces and violently throwing them.

10. Turn saw off and remove yellow key.
11. Unplug saw at the end of cutting session.

Adjustments for Ripping

⚠ DANGER: You will need to make blade guard, anti-kickback pawls and spreader adjustments before making a rip cut.

Blade Guard Adjustments

1. Unplug saw and remove yellow key.
2. Put saw in In-Rip position and lock the saw arm in the 0° position.

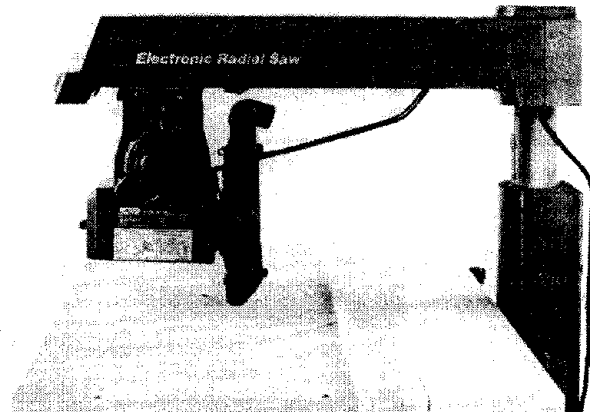

Fig. 155 In-Rip Saw Position

3. Lock rip, miter, bevel, swivel and table locks.

4. Go to the in-feed end of the saw blade. Fig. 154.

5. Put the workpiece on the table, in line with blade and under the nose of blade guard, so it touches the blade.

6. Loosen the guard clamp screw and rotate the guard until the guard nose just clears the workpiece. Fig. 156.

7. Tighten the guard clamp screw.

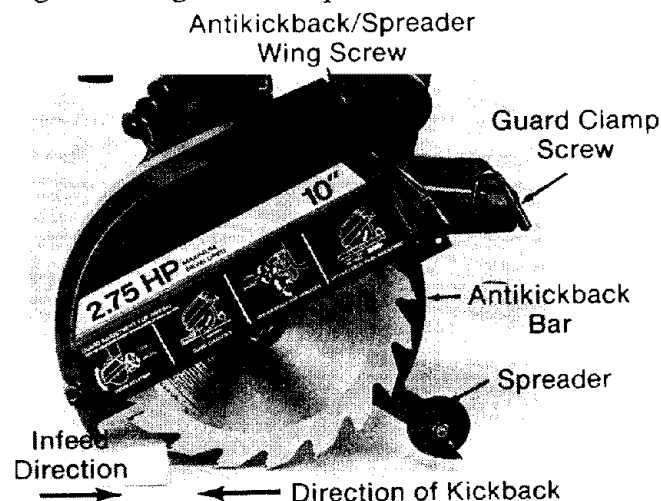

Fig. 156 Blade Guard Position for Ripping

Anti-kickback Pawls and Spreader Adjustments

1. Go to the outfeed end of the saw blade.
2. Put edge of workpiece beside the blade and under the pawls.
3. Loosen wing screw and lower the anti-kickback pawls and spreader until the spreader hangs next to the edge of the workpiece and the pawls, on one side of the spreader, rest on the workpiece.

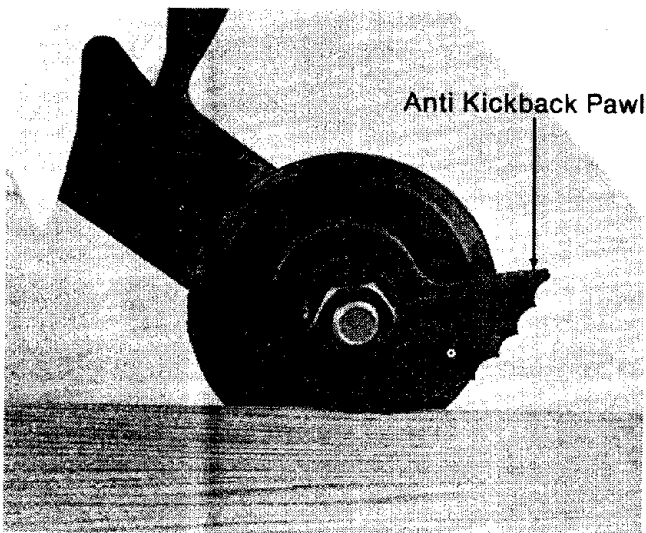

Fig. 157 Anti-kickback Pawl Position

4. Tighten wing screw.
5. Go to the infeed end of the saw blade.
6. Push the workpiece a few inches in the direction of the cut and then pull the workpiece back toward you. The pawls should have grabbed the wood and stopped the kickback motion by grabbing into the workpiece. If they did not, repeat adjustments until the pawls grab the workpiece. If the pawls fail to grab the workpiece, sharpen or replace them. If that fails to work, use a featherboard. Repeat steps for making anti-kickback pawls and spreader adjustments above.

Making Rip Cuts

When to Use In-Rip or Out-Rip

The in-rip saw position provides better visibility of both the workpiece and your hands than does the out-rip saw position. The only time you should use the out-rip saw position is when the workpiece is 14 inches or wider. Use the in-rip position for all workpieces less than 14 inches wide.

Workpiece Positioning for Ripping

Always set up the saw blade so the widest part of the workpiece is between the blade and the fence. For example, if you want to take 1 inch off an 11 inch wide workpiece, set the saw blade 10 inches from the fence. Do not rip 1 inch off an 11 inch workpiece by setting the saw blade 1 inch from the fence.

⚠ WARNING: If the blade is set between 2 inches and 6 inches from the fence, hands will be brought too close to the blade. Fingers and hand can be cut off. Use a push stick.

For example, if the workpiece is 7 inches wide and you want to cut 1 inch off the workpiece, place the saw blade 6 inches from the fence and use a push stick. Use a push stick when the distance between the saw blade and fence is between 2 inches and 6 inches. See Cutting Accessories section on how to make and use a push stick.

⚠ WARNING: If the blade is set between 1/2 inch and 2 inches from the fence, hands will be brought too close to the blade. Fingers/hand can be cut off. Use an auxiliary fence/push block.

For example, if the workpiece is 3 inches wide and you want to cut 1 inch off the workpiece, place the saw blade 2 inches from the fence and use a push block and auxiliary fence. See Cutting Accessories section.

⚠ WARNING: When making through rip cuts do not set the blade closer than 1/2 inch from the fence or auxiliary fence, your hands will be brought too close to the blade. Your fingers and hand can be cut off. Do not use a radial arm saw to rip cut less than 1/2 inch wide workpieces.

1. Set the blade to desired distance from the fence and lock the saw arm in the 0° position.
2. Lock rip, swivel, miter, bevel and table locks.
3. Make blade guard, anti-kickback pawls and spreader adjustments.
4. Remove workpiece from table.
5. Turn saw on.
6. Place workpiece under the guard nose, keeping workpiece edge against the fence.
7. Place one hand flat on the workpiece and next to fence.
8. Place the other hand behind the first so that your fingers are:
 - on the back edge of workpiece;
 - out of the blade path and,
 - as close to the fence as possible.

⚠ WARNING: Even when all steps to reduce kickback are taken, the workpiece can still kickback. You or others in the area can be hit hard enough to cause broken bones or internal organ injury. Stand out of the line of the saw blade and workpiece.

9. Stand out of the line of the workpiece to be clear of workpiece in case of kickback.



Fig. 158 Hand and Body Position for Making an In-Rip Cut

10. Position your body at the infeed end of the saw blade. Start and complete the cut from that same side.
11. Push the workpiece, putting pressure on the part of the workpiece between the blade and the fence. If you push the part of the workpiece on the other side of the blade, the blade could be pinched and the workpiece will kickback.
12. Keep pushing the section of the workpiece between the blade and the fence until the piece has been pushed completely past the anti-kickback pawls.

⚠ DANGER: The blade guard does NOT provide complete protection at out-feed end of the saw blade. The workpiece could kickback as you reach for, touch or pull the workpiece through the blade, pulling your hand into the blade. Fingers, hand, or arm can be cut off. Do not pull, hold-down or touch the workpiece at the outfeed end of the saw.

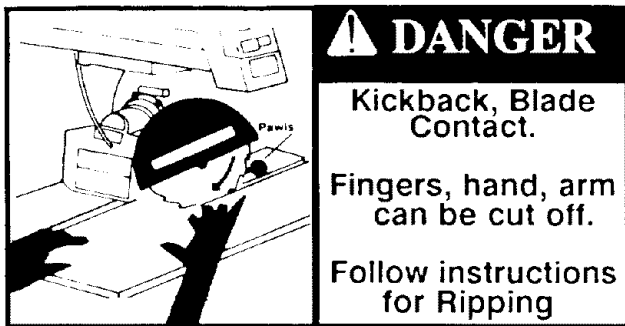

Fig. 159 Kickback, Blade Contact Safety Sign

13. Turn the saw off

⚠ WARNING: Blade continues to turn for about 12 seconds after power is turned off. Do not reach for cut workpiece until blade stops. Fingers or hand can be cut off by the turning blade. Wait for blade to stop turning.

14. Remove yellow key from red switch.

Bevel Ripping

To make a bevel rip cut:

1. Set the saw in the desired position.
2. Index the arm to 0° and lock in position.
3. Bevel the blade to the desired angle.
4. Follow steps for making a rip cut.

Note: For dadoing, molding and edging, follow instructions for crosscutting.

Dadoing

1. Instructions for using dado blades are provided with the dado blade.
2. The saw arbor is designed for a dado set up to 13/16 inches wide. Use of a wider dado

on the arbor could cause the dado and arbor nut to spin off. Take several passes of the dado if cut required is greater than 13/16 of an inch wide.

3. To avoid excessive load on the motor never cut a 13/16 inch wide dado deeper than 1/8 inch in one pass.

4. When installing the dado on the arbor, always install the inside loose collar first to ensure good arbor nut engagement. Make sure the arbor nut is snug. Install the arbor nut directly against the outside of the dado.

Molding

1. Instructions for using the molding head are provided with the molding head.
2. Use of molding head or drum sander with the saw arbor vertical requires an opening (next to rear face of fence) for saw arbor clearance. See Cutting Accessories section to make a molding fence.

Edging

1. Edging requires the use of a dado or molding head in the horizontal position (parallel to table).
2. Use proper accessory guard when edging. See Recommended Accessories section.

⚠ WARNING: Using the saw without the proper accessory guard for edging is extremely dangerous. Hands, fingers or arm can be cut off. Buy, use and follow instructions for edging guard.

3. Use an auxiliary fence when edging with the radial arm in the 0° miter position. See Cutting Accessories section to make auxiliary fence for edging in the 0° miter position.

⚠ WARNING: If the auxiliary fence is not used when the saw arm is in the 0° crosscut position, the molding head cannot be located behind the fence for safe and proper operation.

4. Edging can also be done in the 30° left miter without the use of an auxiliary fence. Follow the instructions below.

- Miter the arm to the left approximately 30°.
- Swivel the motor until bottom of motor is parallel to and facing the rip fence and operating instructions label is visible.
- Follow all steps outlined on motor label as shown below.

DANGER BEFORE EDGING

Know this tool:

1. Read and Understand all warnings and instructions on saw, in Owner's Manual and with recommended accessories.

2. Properly guard the cutting tool.

3. Provide proper workpiece support.

4. Position the cutting tool behind the fence by moving the arm to the left and clamping the yoke so this label faces the fence, or construct an auxiliary fence per Owner's Manual.

5. With power off, the switch key removed, turn cutting tool by hand to make sure it does not strike guard, fence or any other saw parts.

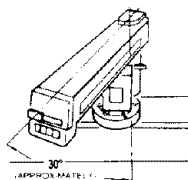

Fig. 160 Edging Label

Accessory Safety

1. For your safety use only recommended accessories. Use of any other accessories may increase the risk of injury. See Recommended Accessory section of manual.
2. Use of grinding wheels, abrasive or cut off wheels, or wire wheels is dangerous because they can break explosively and throw pieces. You can be blinded or receive a life threatening puncture wound. Do not use grinding wheels, abrasive/cut off wheels or wire wheels.

3. Remove saw blade, dado, or other accessory from the saw arbor shaft before using the accessory shaft. Do not use the saw with accessories installed on both ends of the saw arbor shaft at the same time.

4. Make sure the unused shaft is covered by a guard, the arm, or the screw cap to avoid being pulled into moving parts by hair, threads, clothing.

5. Drill chucks can bend and pieces of the drill bit can break. You can be blinded or injured if hit by thrown pieces. Do not use twist drills longer than 7 inches.

6. Use a spade type drill of 1 inch diameter or smaller. Use for drilling only wood or plastic because the speed is not high enough for other types of materials.

7. Do not use other reduced shank drills.

8. Remove adjusting wrenches. Form habit of checking to see that adjusting wrenches are removed from tool before turning it on.

9. When using the accessory shaft in the vertical position, swivel the motor 90° so that the arbor shaft is under the radial arm as shown.

⚠ WARNING: Clothing, hair, jewelry can be caught and pulled into an exposed arbor shaft. Fingers, hand or arm can be broken or cut off. Place the arbor shaft under the radial arm when using the accessory shaft.

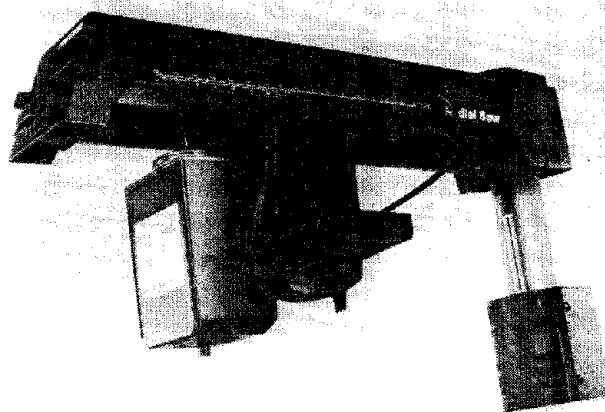

Fig. 161 Arbor Shaft Position When Using Accessory Shaft

Cutting Accessories

Fences

Fences are required for all saw operations.

Crosscutting requires fences with kerfs (slots) to match the path of the saw, because the saw blade is pulled through the kerf in the fence to cut the workpiece.

Ripping requires a solid fence with no kerfs or slots, because the fence serves as a guide for the workpiece being pushed into the saw blade. If the workpiece is pushed along a fence with kerfs, the workpiece can get caught on a kerf, pinch the blade and cause the workpiece to kickback.

Make a new fence:

- when the fence used for crosscutting has weakened from having too many kerfs cut in it;
- when you want to make a rip cut but the fence on the saw has kerfs;
- when you want to crosscut a workpiece higher than your current fence.

To make a new fence:

1. Use 3/4 inch knot free lumber. Do not use particle board or other composite material because they are not strong enough.
2. Cut lumber to a length equal to the length of the table, and to a width more than half the height of the workpiece being cut, but never less than 3/4".

Push Stick

Push sticks are used during ripping when the blade is placed between 2 and 6 inches from the fence.

Make a push stick when:

- the blade is to be placed 2 to 6 inches from the fence;
- existing push stick has been damaged.

To make a push stick:

1. Use 3/4 inch solid (knot free) piece of lumber.
2. Cut a piece 15 inches long by 1 5/8 inches wide.
3. Cut a 45 degree notch in one end as shown.

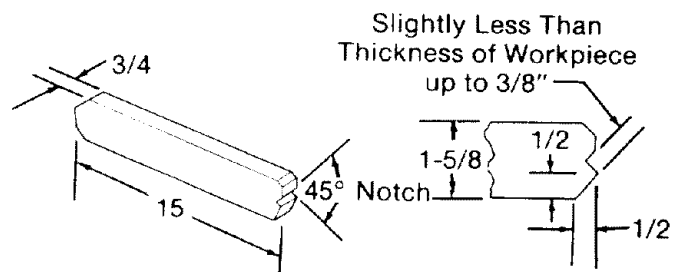

Note: All Dimensions in Inches

Fig. 162 Push Stick Dimensions

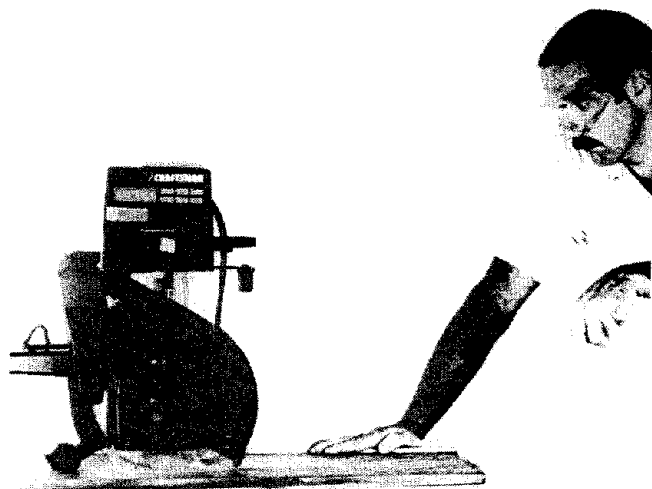

Fig. 163 Way to Use Push Stick

Auxiliary Fence and Push Block

An auxiliary fence must be used if the blade is positioned between 1/2 inch and 2 inches from the fence during ripping. An auxiliary fence must always be used with a push block. Their purpose is to keep your hands away from the saw blade. They are also needed when you use the molding head.

Make an auxiliary fence when:

- the blade is to be placed 2 inches or less from the fence;
- an existing auxiliary fence is not the same width all along its length;
- the existing auxiliary fence has been damaged by blade contact.

To make auxiliary fence:

1. Use one piece of 3/8 inch plywood and two pieces of 3/4 inch plywood.
2. Cut the 3/8 inch plywood to 44 inches long by 5 1/2 inches wide.
3. Cut one piece of 3/4 inch plywood to 44 inches long by 3 5/8 inches wide.
4. Cut other piece of 3/4 inch plywood to 44 inches long by 2 1/4 inches wide.
5. Glue the two 3/4 inch plywood pieces together so that they line up square (flush) on an edge.
6. Glue the 3/8 inch plywood piece at right angle to and flush against the 2 1/4 inch wide 3/4 inch plywood.
7. Reinforce with nails.

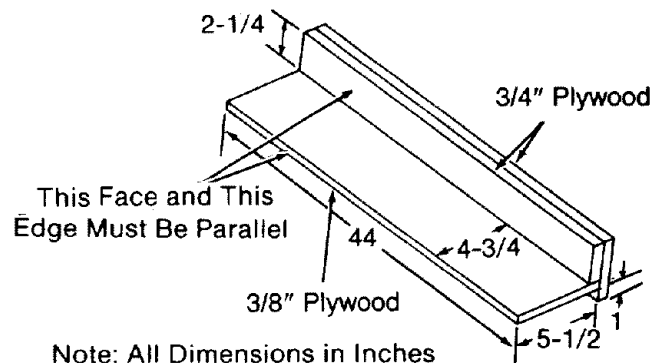

Note: All Dimensions in Inches
Fig. 164 Auxiliary Fence Dimensions

Push Block

Push blocks are always used with an auxiliary fence.

Make a push block when:

- the blade is to be placed 1/2 inch to 2 inches from the fence;
- you make the first auxiliary fence;
- existing push block has been damaged.

To make a push block:

1. Use one piece of 3/4 inch plywood and one piece of 3/8 inch plywood.
2. Cut the 3/4 inch plywood to 12 inches long by 5 inches wide.
3. Cut a triangular piece off each of two corners of the 12 inch side by marking with a pencil in and down from the corners 1 1/4 inches and cutting along the diagonal formed by the points.
4. Cut the 3/8 inch plywood to 12 inches long by 5 1/8 inches wide.

5. Cut out a notch from the 12 inch side of the 3/8 plywood that is 9 1/2 inches long by 3/8 inch wide. The dimensions of the remaining 3/8 plywood are shown in Fig. 165.

6. Glue the 3/4 inch plywood on top of the 3/8 inch plywood so that their 12 inch sides are square, as shown;

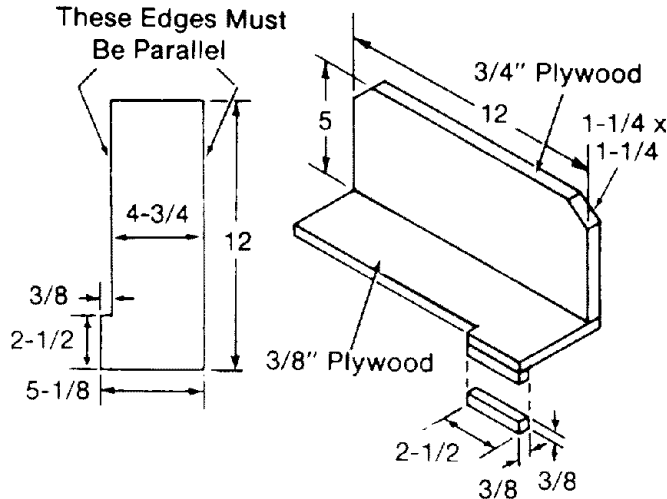

Note: All Dimensions in Inches

Fig. 165 Push Block Dimensions

7. Cut a piece of plywood 3/8 inch wide by 2 1/2 inches long and glue it to the underside of the 3/8 inch plywood in line with the edge that sticks out. Do not use nails because if you accidentally cut into the push block with the saw blade, the nails will dull the blade.

8. Lay the push block on top of the auxiliary fence to make sure that their widths match exactly, and are each 4 3/4 inches.

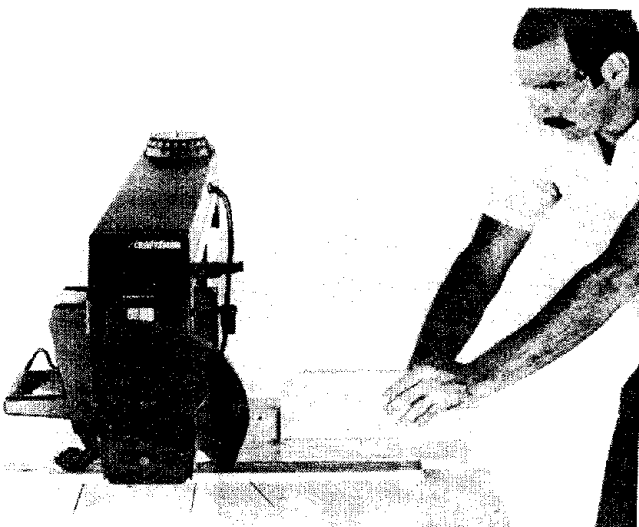

Fig. 166 Way to Use Auxiliary Fence/ Push Block

Auxiliary Fence for Edging

Make an auxiliary fence for edging:

- before doing edging with the arm at 0° miter position.
- when existing ones have been damaged.

To make a fence for edging:

1. Use 3/4 inch solid (knot-free) lumber.
2. Cut to the dimensions shown.

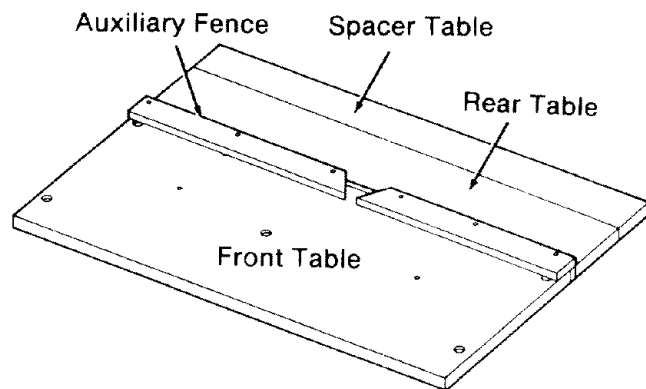

Note: All Dimensions in Inches

Fig. 167 Auxiliary Fence for Edging

For use of the molding head or drum sander with saw arbor vertical, the rear table requires an opening (next to rear face of fence) for arbor clearance. Cut opening directly below arbor in vertical position. Opening dimensions are shown below.

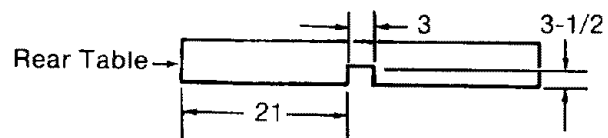

Note: All Dimensions in Inches

Fig. 168 Rear Table Opening Dimensions

When operating the drum sander the motor **must** be blown or vacuumed frequently to prevent sawdust buildup which will interfere with normal motor ventilation.

Featherboard

Featherboards are used during rip cutting to help keep the workpiece against the fence. The featherboard is clamped to the front table, so that the angled edge of the featherboard is against the workpiece on the infeed end of the blade. The other edge of the workpiece is against the fence.

Make new featherboards when existing ones have been damaged.

1. Use solid (knot free) lumber 24 inches by 5 1/2 inches by 3/4 inch.
2. On the 24 inch sides mark a point 5 1/2 inches down on the left and 9 1/2 inches down on the right from the edge of the board. Draw a line between the points.
3. Crosscut workpiece at a 30° angle then rip to make the kerfs.
4. Do not clamp the featherboard against the cut off part of the workpiece.

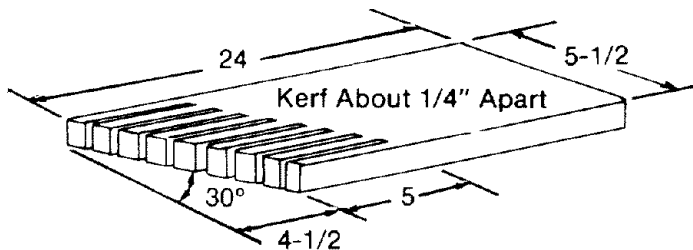

Note: All Dimensions in Inches

Fig. 169 Featherboard Dimensions.

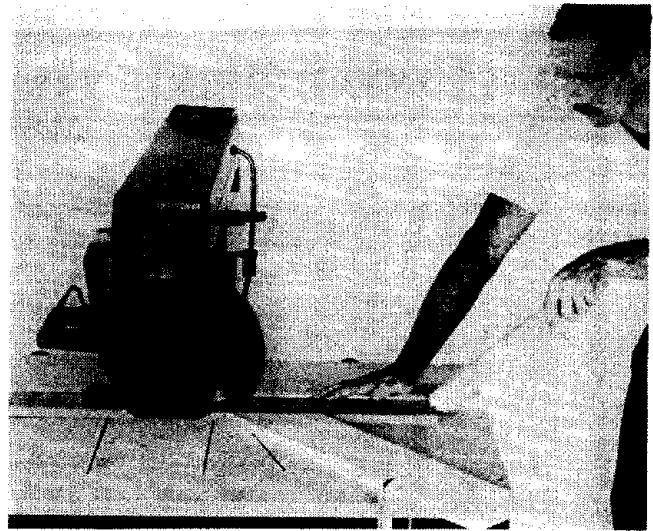

Fig. 170 Way to Use a Featherboard

Attaching Auxiliary Board to Crooked Workpiece

If the workpiece you want to rip cut does not have a straight edge, attach an auxiliary board to the workpiece.

1. Place irregular side of workpiece against fence.
2. Place straight edged auxiliary board on top of workpiece and against fence.
3. Tack the auxiliary board to the workpiece. The auxiliary board must not extend beyond the leading end of the workpiece and should cover the workpiece width only enough to pass between the blade and fence.
3. Use a fence that is equal to or higher than the combined height of the workpiece and auxiliary board.

Sears Recommends The Following Accessories

Item	Cat. No.
Saw blades (10" diameter with 5/8" hole)	See Catalog
Caster	9-22254
Sanding Drum	9-25246
Drill Chuck and Key	9-2980
Dust Collector	See Catalog
Molding Head Guard 8"	9-29523
Taper Jig	9-3233
Auxiliary Table Cover	See Catalog
Miter Square	9-32056
Extension Table	9-32795
Satin Cut Dado	
7"	9-3257
8"	9-3253
8" Carbide	9-3264
Standard Cut Dado	
8"	9-32475
Adjustable Dado	
7"-24 Tooth Carbide	9-3261
7"-32 Tooth Carbide	9-3262
7"-16 Tooth Carbide	9-3263
8"-48 Tooth Carbide	9-32708
Molding Heads	
7"-Bits Not Included	9-3214
7"-27 Piece Set	9-3217
7"-15 Piece Set	9-3218
Sanding Wheel-10"	9-22723
Cabinet Accessories	
Shelf	9-22251
Door	9-22252
3 Drawer Set	9-22253
Books	
Power Tool Know How Handbook	See Catalog
Guards	
Lower Retractable Guard (For 90° Crosscut Only)	9-29009

Recommended means that these accessories are designed to fit this radial arm saw. Read and follow accessory instructions on their use and limitations.

Lower Blade Guard Safety Information

IMPORTANT

The following safety information and instructions apply to all blades and accessories.

The lower blade guard is required by the Occupational Safety and Health Administration (OSHA) if the radial saw is used commercially. The lower blade guard is intended for use only in repetitive 90° crosscutting.

Repetitive 90° Crosscutting is the repeated and continuous cutting of many pieces of lumber to the same length with the saw placed in the 90° crosscut position.

In repetitive 90° crosscutting, the guard may reduce the chance of accidentally touching the blade from the side. This protection is possible **ONLY** when:

- the blade is in its rearmost position and
- the guard is resting on the table so the leading and trailing teeth of the blade are not exposed from the sides.

The lower blade guard **ONLY** provides protection against minor cuts and bruises that occur from contact with the flat sides of the spinning blade.

▲ WARNING: The lower blade guard will not provide any protection if the blade is pulled over your hand, or your hand enters the blade path from the front or rear of the blade. Fingers or hand can be cut or cut off.

▲ WARNING

Remove the lower blade guard for **ALL** other types of cuts except repetitive 90° crosscutting. Using the lower guard other than for repetitive 90° crosscutting will increase the risk of certain hazards:

- During rip and bevel cuts the workpiece or narrow cut-off pieces can be pinched between the guard and the blade. Workpiece or cut-off pieces can kickback.
- In the bevel position the blade teeth are fully exposed. Fingers or hand can be cut off.
- Cut off pieces can jam between the guard and blade. Turn saw off and wait for blade to stop before freeing a jammed guard or blade.
- Workpiece or cut-off pieces can be violently thrown by the blade. Wear safety goggles.

▲ CAUTION

The lower blade guard can get caught or jam in fence or table kerfs.

Read and follow the warning on the lower outer guard:

WARNING:
TO AVOID INJURY
SHUT OFF POWER
BEFORE CLEARING A
JAMMED LOWER GUARD

Read saw manual for additional saw use and safety information.

Glossary

Anti-kickback Pawls: Pivoted objects with teeth which help prevent workpiece kickback.

Arbor: The bar or shaft that holds the saw blade.

Bevel: The slanting of the motor and blade to an angle between 0° and 90°.

Crosscut: Cutting a workpiece to length.

Dado: Non-through cut which produces a square sided notch or trough in the workpiece.

Featherboard: Device used to keep workpiece in contact with the fence during ripping.

Freehand: Performing a cut without the use of fence, guide or hold-down designed to prevent the workpiece from moving during the cutting operation.

Heel: Misalignment of the blade relative to blade travel path.

Infeed: The end of the saw blade where the workpiece is fed during ripping; identified by the absence of pawls.

In-Rip: Positioning the the motor toward the front of the table, the blade toward the fence.

Kerf: Slot caused by removal of material by the blade in a through cut, or a shallow slot produced by the blade in a non-through cut.

Kickback: Uncontrolled throwing of the workpiece during ripping.

Miter: Positioning the saw arm to the right or left of 0°.

Molding Cut: Non-through cut which produces a contoured surface on the workpiece.

Outfeed: The end of the saw blade where the rip cut workpiece leaves the saw blade; identified by presence of pawls.

Out-rip: Positioning the motor toward the fence, the blade toward the front of the table during ripping.

Parallel: When two surfaces are the same distance apart at all points.

Perpendicular: When two surfaces are 90° (square) to each other.

Push Block/Auxiliary Fence: Two accessories used together for ripping a workpiece between 1/2 inch and 2 inches wide.

Push Stick: Cutting accessory used during ripping a workpiece between 2 inches and 6 inches wide.

Revolutions Per Minute (RPM): Number of turns completed by an object in one minute.

Ripping: Used to change the width of a workpiece by cutting along its length.

Spreader: Used during ripping to keep the kerf from closing and pinching the blade. It helps prevent kickback.

Workpiece: Object being cut by the saw.

Helpful Hints

In order to get accurate cutting results from your radial arm saw, do the following:

1. Follow all steps in the Alignment of the Blade section.
2. Place the long edge of your framing square against the edge of the workpiece that will be held against the fence during cutting. Make sure that this edge of the workpiece is straight.
3. Make sure that your workpiece lays flat on the front table of your saw.
4. Clean all sawdust and woodchips from the table.
5. Hold the workpiece firmly against the fence and table during all cuts. You should use extra force during miter and bevel cuts since the workpiece tends to move when these cuts are made.
6. Use the right sawblade for each job, and make sure that all blades and cutting tools are sharp.

3. Place the same edge of the workpiece against the fence for all cuts. Make the first cut at one end of the workpiece, then flip the workpiece over and make the second cut from the other end. Continue this way until all four cuts are made. (Figure 171)

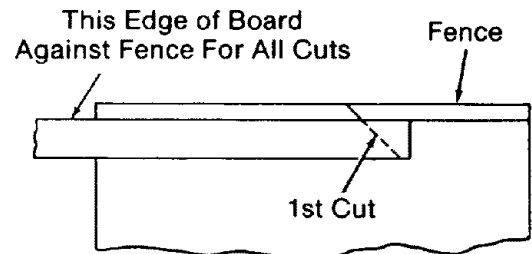

Turn workpiece over end for end . . . keep same edge against fence when making successive cuts.

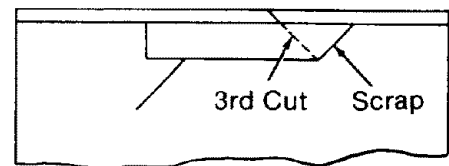
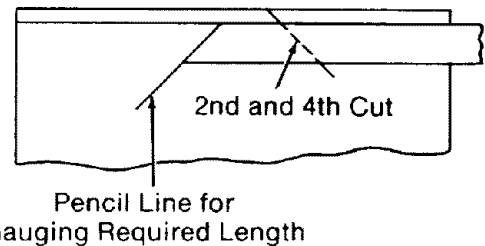

Fig. 171 - Making a 4-Sided Frame

When making a four-sided frame:

1. Make sure that the top and bottom pieces are exactly the same length.
2. Make sure that both side pieces are exactly the same length.
4. Make a pencil line on the table for gauging the length of each cut.

To extend the life of the front table of your saw, tack a piece of 1/4 inch plywood over it. Make sure that the tacks are not in the path of the saw blade.

Use of a front table cover does the following:

- Allows all cuts to be made in the cover rather than the front table.
- Slows the dulling of the blade.

There are three pre-set miter angles at 45°, 0°, and -45°, five pre-set bevel angles at -90°, -45°, 0°, 45°, and 90°, and three pre-set swivel angles at the crosscut, in-rip and out-rip positions. When you are moving the arm, blade, or motor into one of these positions, do the following:

1. Move the arm, blade, or motor past the position you want, and then gradually bring it back.
2. Once the arm, blade, or motor snaps into the desired position, push it to the right as far as possible within this position. Movement of the arm, blade, or motor will be slight.

3. Lock the miter, bevel, or swivel lock.

These steps will reduce stress on saw parts, and improve the accuracy of your cuts.

The following table is provided to convert the decimal numbers on the digital display to fractions. All decimals are rounded to the nearest .01 inch. (Figure 172)

$\frac{1}{32}$.03	$\frac{17}{32}$.53
$\frac{1}{16}$.06	$\frac{9}{16}$.56
$\frac{3}{32}$.09	$\frac{19}{32}$.60
$\frac{1}{8}$.12	$\frac{5}{8}$.63
$\frac{5}{32}$.16	$\frac{21}{32}$.66
$\frac{3}{16}$.19	$\frac{11}{16}$.69
$\frac{7}{32}$.22	$\frac{23}{32}$.72
$\frac{1}{4}$.25	$\frac{3}{4}$.75
$\frac{9}{32}$.28	$\frac{25}{32}$.78
$\frac{5}{16}$.31	$\frac{13}{16}$.81
$\frac{11}{32}$.34	$\frac{27}{32}$.85
$\frac{3}{8}$.38	$\frac{7}{8}$.88
$\frac{13}{32}$.41	$\frac{29}{32}$.91
$\frac{7}{16}$.44	$\frac{15}{16}$.94
$\frac{15}{32}$.47	$\frac{31}{32}$.97
$\frac{1}{2}$.50	1	1.00

Decimal Equivalent

Fig. 172

Maintaining Your Saw

General

⚠ WARNING: For your own safety, turn power switch off and remove plug from power source outlet before maintaining or lubricating your saw.

When you receive your new Craftsman radial saw, it requires no lubrication. The radial saw has been partially aligned and all bearings are lubricated and sealed for life. In time, however, in order to keep your saw in perfect working order and accurate, it will be necessary to lubricate and realign. In fact your radial saw needs more of a cleaning than a lubrication.

Replacing Antikickback Pawls

Make sure the teeth of the *antikickback pawls* are always sharp. If they become dull they must be replaced. With a 1/2 inch wrench or socket remove the 5/16 hex nut and old *pawls*. Reassemble new *antikickback pawls* and *spreader* to the bar. Check *spreader* for proper alignment and correct if necessary. (See Alignment of the Blade, Installing Guard / Setting Spreader section.)

Cleaning

Periodically remove any heavy build-up of sawdust that may accumulate on the saw. The absorbing tendency of sawdust will draw lubricants away from the areas where they are needed. Clean the *carriage bearings* and *track* surfaces. If packed sawdust and grease accumulate repeatedly on carriage bearings and track inspect the *wipers* for wear and replace if necessary. (See Adjustments to Compensate for Wear, Swivel Lock, later in this section.)

To avoid motor damage the *motor* should be blown out or vacuumed frequently to prevent sawdust build-up which will interfere with normal motor ventilation.

Lubrication

Your saw is precision built and should be kept properly lubricated. Before describing the various points which may periodically require lubrication, it is more important to first mention the points which should **not** be lubricated.

Do not lubricate the following:

- carriage ball bearings
- motor bearings
- area between the miter locking rings and the column tube

The *carriage ball bearings* and *motor bearings* are sealed ball bearings which require no added lubrication.

Do lubricate the following, periodically, using SAE No 10W-30 automotive engine oil:

- Apply a few drops of oil along the *swivel index pin* and the *bevel index pin* only if the pins have a tendency to stick. Swivel to in-rip or out-rip for easy access to the *swivel index pin*. Bevel to 45° and *bevel index pin* can be easily accessed behind the *yoke* as illustrated (Figure 173)

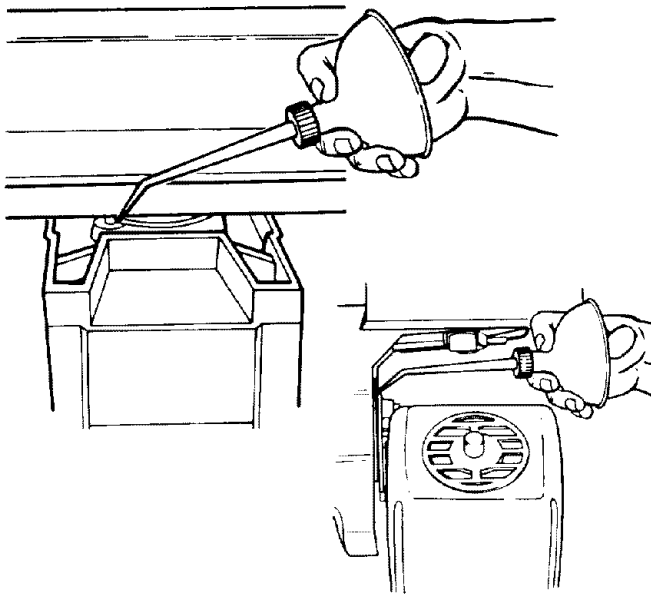

Fig. 173 - Swivel and Bevel Index Pins

- Lubricate the bearing points where the *arm* attaches to the *column tube*. With a #2 Phillips screwdriver remove two screws and the rear arm cover for access to these points. Be careful not to get lubricant on the *locking rings* as this will adversely affect the miter locking function. (Figure 174)

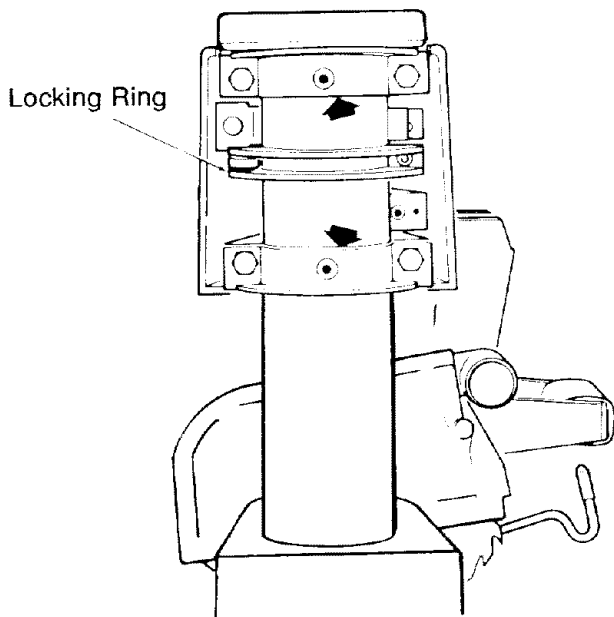

Fig. 174 - Bearing Points Where Arm Attaches to Column Tube

- Lubricate the cam surfaces of the *rip lock* assembly.
- A light film of oil should be wiped on the face of the *column tube* to lubricate the fit between the *column tube* and *column support*. Turn the elevation *handwheel* to raise the arm to its upper limit. Wipe a light film of oil on the face of the column tube.

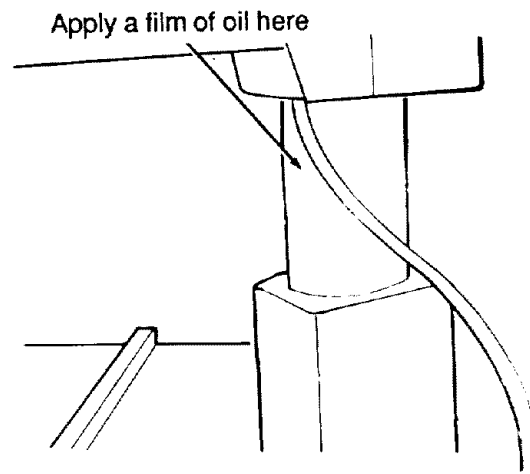

Fig. 175 - Oiling column tube.

- The thread on the *elevation shaft* assembly can be lubricated through the oil hole in the center of the *radial arm cap*. Lubricate ramp on the *swivel index spring*.
- Apply a few drops of oil to the *foot assemblies*, where the *levers* are inserted through the *rods*.

Do not use too much oil. Excessive oil at any location will attract airborne dust particles and sawdust.

Refer to parts lists for locations of parts as needed.

Adjustments for Wear

Bevel Lock

The purpose of the *bevel lock* is to lock the *motor* at any bevel angle. An adjustment is required if the *motor* can be easily moved by hand when the *bevel lock* is locked or if *bevel lock* offers minimal resistance when moving it to the locked position. To make this adjustment:

1. Remove *motor support cover*.
2. Position the motor at approximately 30° bevel angle and lock *bevel lock*. (Figure 176)

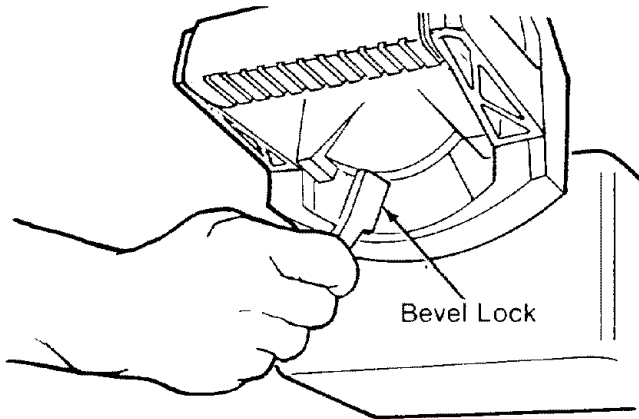

Fig. 176 - Bevel Lock - Locked

3. With a 3/4 socket tighten the 1/2-13 hex nut located at the back of the *motor support casting* until the *motor* can no longer be easily moved by hand. Do not overtighten.
4. Unlock *bevel lock* and move *motor* to any of the five index positions. If the *motor* does not index securely the adjustment is too tight. Loosen 1/2-13 hex nut until *bevel index pin* seats properly.

5. Adjustment is complete when both locking and indexing functions are working properly. Replace *motor support cover*.

Swivel Lock

This *handle* provides a friction lock between the upper face of the *yoke* and the bottom face of the *carriage*. It should eliminate any play or rotation between these two parts when locked. An adjustment is required if the *yoke* can be easily rotated by hand when *handle* is locked or *yoke lock handle* offers minimal resistance when moving *handle* to the locked position. To make this adjustment:

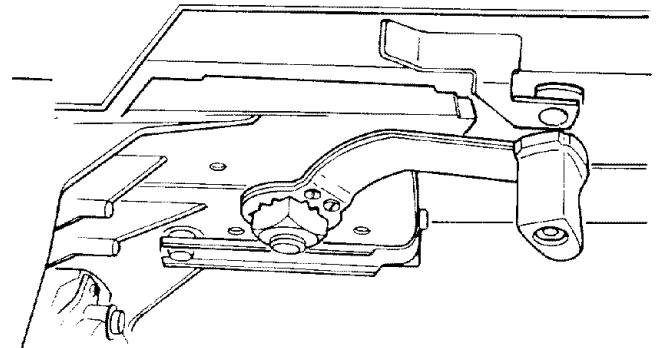

Fig. 177

1. Remove screw and nut from knob on swivel lock. Remove knob from swivel lock lever using a regular screw driver.
2. Separate the wrench from the lever by rotating the wrench a few degrees counter-clockwise from the lever to disengage tab.
3. Using the wrench portion tighten the square nut one quarter rotation at a time. This is done by locating the wrench across the corners of the square nut then moving the wrench until it lines up with the lever portion and the two screw holes are in line.

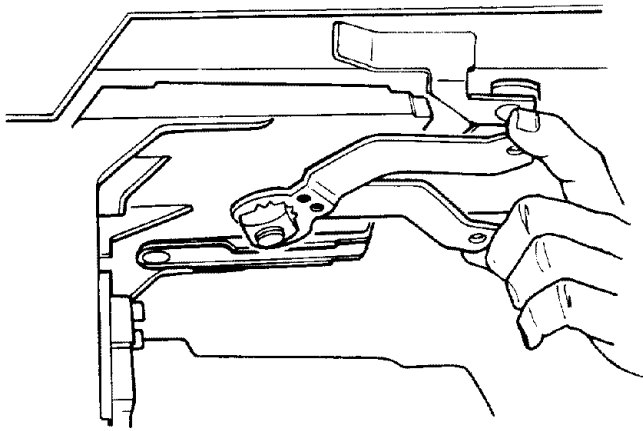

Fig. 178

4. Holding the *wrench* and *arm* in position rotate *yoke* to a non-preset position and rotate *swivel lock* to the locked position. If the *yoke* can still be moved the *square nut* has not been tightened enough. Repeat step 3.

5. When the adjustment is such that the *yoke* can no longer be moved when the *swivel lock* is in the locked position. Reinsert the *tab* on the *wrench* into the slot in the lever.

6. Unlock *swivel arm* and rotate *yoke* to a non-preset position. Return *yoke* to a rip position. If the *index pin* does not securely seat at the preset position, the adjustment is too tight. Remove the two *screws* and loosen the *square nut* one quarter turn until *swivel index pin* seats securely.

7. Adjustment is complete when both locking and preset position functions are working properly.

8. When the adjustment is such that the *yoke* can no longer be moved when the *swivel lock* is in the locked position. Reinsert the *tab* on the *wrench* into the slot in the lever.

9. Re-install *knob* to *swivel handle* and install *screw* and *nut* in *knob*.

Arm and Column

With the *miter lock* unlocked and in the unindexed position the *arm* should fit snugly to the *column tube* and not allow any vertical movement. If you can move the end of the *arm* up and down an adjustment is needed.

1. With a #2 Phillips screwdriver remove two screws and the *rear arm cover*.

2. With a 9/16 inch wrench or socket tighten evenly the top two 3/8-16 hex head tapping screws. The bottom two screws should also be tightened evenly but not as tight as the top screws. (Figure 179)

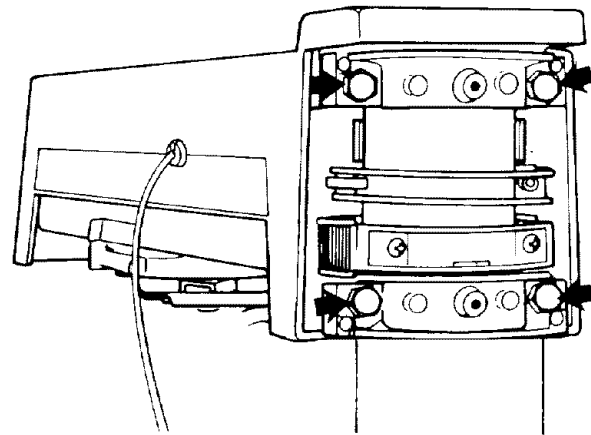

Fig. 179 - Location of Hex Head Tapping Screws

3. This adjustment is correct when the *arm* moves firmly without vertical movement.

4. Re-install the *rear arm cover*.

Carriage Bearings

The *carriage* should roll freely but with some resistance for the entire length of travel. To check for bearing looseness, perform the following steps.

1. Place *yoke* in either the in-rip or out-rip position.

2. Push the *carriage* back against the rear stop.

3. Hold the *front carriage bearing* with your fingers as tight as possible and pull *carriage* forward at the same time. If you can prevent the *bearing* from turning an adjustment is required. (Figure 180)

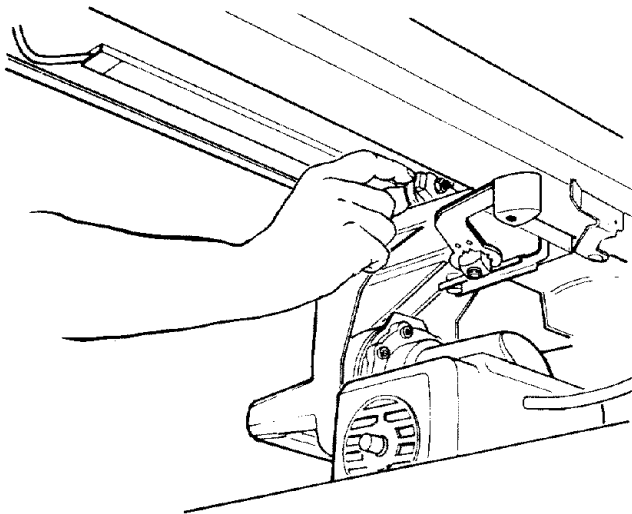

Fig. 180 - Front Carriage Bearings

4. Repeat step 3 with the *rear carriage bearings*.

To adjust the *carriage bearings* perform the following steps:

1. Clean and lubricate the bearing races and the bead on which they ride prior to adjustment.

2. To adjust the bearing, use a 9/16 inch wrench to hold the bolt head while using a 1/2 inch wrench to loosen the hex nut. (Figure 182)

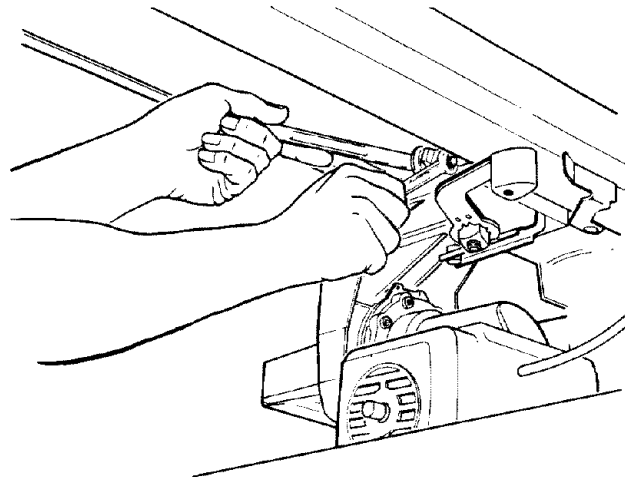

Fig. 182 - Location of Hex Nut

3. Rotate the *eccentric bolts* a partial turn (left or right) as required to take up looseness. Both *bolts* should be adjusted an equal amount to maintain blade squareness to the table in the rip positions.

4. Hold the head of the *eccentric bolts* in their new position and retighten the nuts. Do not overtighten. Overtightening the *bearings* will cause difficult operation and severely reduce the life of the *track* and *bearings*.

5. Repeat the test procedure as described above and readjust if necessary.

Miter Lock

The *miter lock* operates adjustable locking bands which lock the *arm* to the *column tube* in both indexed and unindexed positions. If the *arm* can be easily moved by hand when locked in an unindexed position the following adjustment must be made.

1. Move the *arm* to an unindexed position and leave the *miter lock* in the unlocked position. (Figure 183)

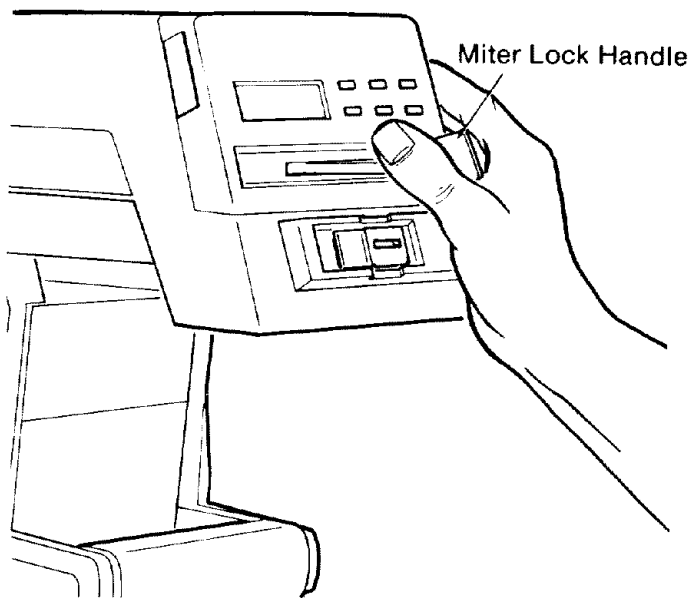

Fig. 183 - Miter Lock - Unlocked

Rip Lock

The *rip lock* locks the *carriage* in any position along the length of the *arm*. If the *carriage* can be easily moved by pushing and pulling on the *yoke handle* when the *rip lock* is in the locked position an adjustment is required.

1. Hold the *rip lock* in the unlocked position and with a 7/16 inch wrench tighten the 1/4-20 hex lock nut 1/4 turn. (Figure 185)

2. With a 3/16 inch hex "L" wrench find the 1/4-20 hex socket cap screw through the hole in the rear of the *arm cover*. To tighten turn the wrench clockwise approximately 1/4 turn. (Figure 184)

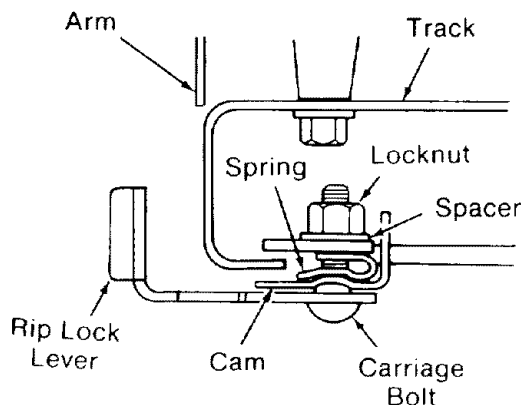

Fig. 185 - Location of Hex Lock Nut

2. Lock the *rip lock* and try again to move the *carriage*. Make additional adjustments if necessary.

3. Place the *rip lock* in the unlocked position and move the *carriage* back and forth from stop to stop. If the *carriage* is difficult to move at any point or you can feel the *rip lock* dragging on the track the adjustment is too tight. Loosen the hex nut one half the amount of the last adjustment and try again.

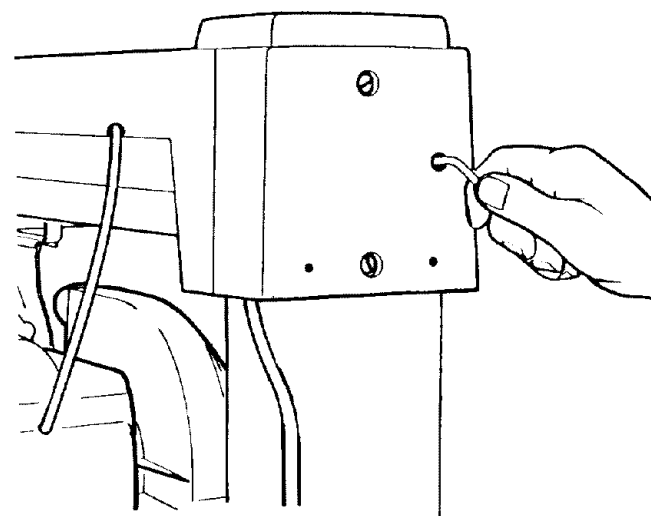

Fig. 184 - Location of Hex Socket Cap Screw

3. Lock the *miter lock* and try again to move the *arm*. Readjust if necessary.

4. If it becomes extremely difficult to push the *miter lock* into the locked position too much adjustment has been made. Turn the wrench counterclockwise one half the amount of the last adjustment and try again to lock the *arm*.

Motor

To avoid motor damage this motor should be blown out or vacuumed frequently to prevent sawdust buildup which will interfere with normal motor ventilation.

Your saw is equipped with a manual reset button designed to open the power line circuit when the motor temperature exceeds a safe level, motor is overloaded, or a low voltage condition exists. (Figure 186)

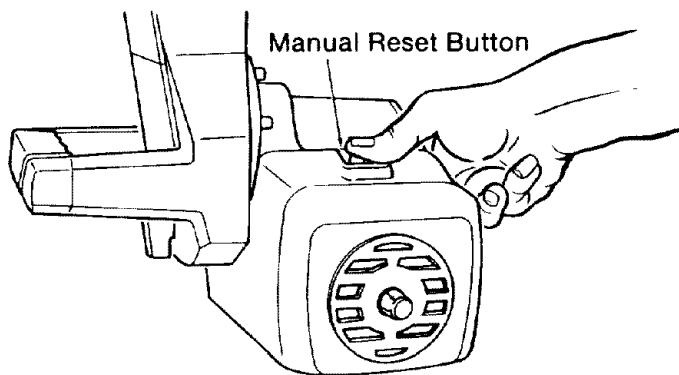

Fig. 186 - Manual Reset Button

1. If the protector opens the line and stops the saw motor, immediately turn the saw switch off, remove the yellow key, and allow the motor to cool.
2. After cooling to a safe operating temperature, the overload protector can be closed manually by pushing the red button on the top of the motor. If the red button will not click into place immediately, the motor is still too hot and must be allowed to cool for a while longer.

The motor may take as long to cool as it did for the heat to build up. An audible click when you push the red button will indicate that the protector is closed (reset) and the saw is ready for use.

3. As soon as the red button will click into running position, the saw may be started and operated normally.
4. Frequent blowing of fuses or tripping of circuit breakers may result if:

- Motor is overloaded: Overloading can occur if you feed too rapidly or if saw is misaligned so that the blade heels.
- Motor circuit is fused differently from recommendations: Always follow instructions for the proper fuse/breaker. Do not use a fuse/breaker of greater capacity without consulting a qualified electrician.
- Low voltage: Although the motor is designed for operation on the voltage and frequency specified on the nameplate, normal loads will be handled safely on voltages not more than 10% above or below the nameplate voltage. Heavy loads, however, require that voltage at motor terminals equal the voltage specified on nameplate.
- Improper extension cord size.

Changing Motor Voltage

BOTH MODELS

⚠ DANGER: To avoid electric shock unplug the saw before changing motor voltage.

Under normal home workshop usage, and if full voltage is supplied to the motor, your saw will operate efficiently on 120V, as connected at the factory. However, if any of the following conditions exist, it will be advisable for you to have a qualified electrician reconnect the motor for 240V operation:

- Heavy duty operations.
- Either an undersized or an overloaded branch circuit serving the saw motor.
- Low voltage supplied by the power source, which the power company cannot correct.

The procedures for changing the motor voltage (factory set for 120V) are described below. These instructions should be followed by a **qualified electrician only**.

Note: Whenever changing the switch position from 120V to 240V or vice versa, make certain that all necessary steps (including proper fusing of the branch circuit) are completed.

Connection for 120V A.C.

1. Remove *motor cover panel* at blade end of motor.
2. Using a small screwdriver, slide *dual voltage switch* to 120V position. Then replace *motor cover panel*.
3. Use 120V power cord furnished with the saw.

Connection for 240V A.C.

1. Remove *motor cover panel* at blade end of motor.
2. Using a small screwdriver, slide *dual voltage switch* to 240V position. Then replace *motor cover panel*. (Figure 187)

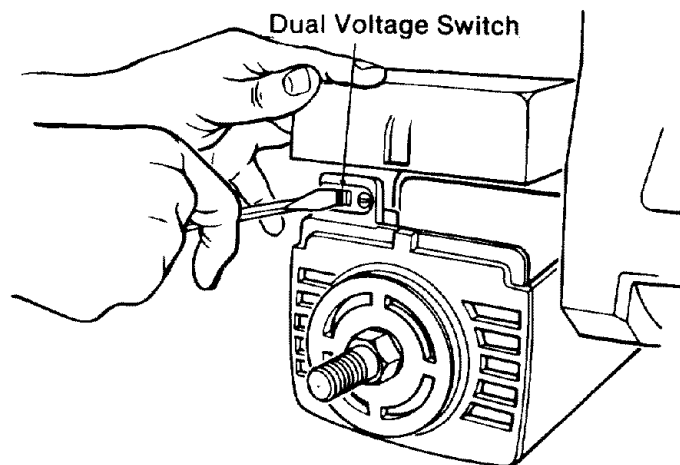
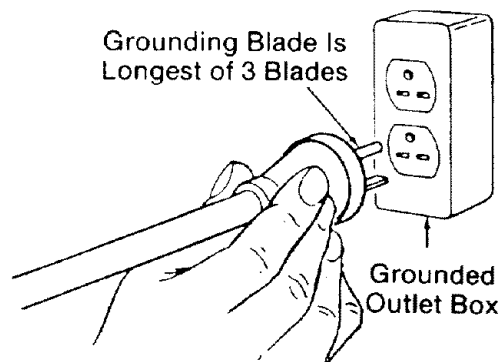

Fig. 187 - Dual Voltage Switch

3. Replace the 120V power cord plug with a 240V, 15 AMP, 3-blade plug. (Figure 188)



No Adapter Is Available For This Type Plug

Fig. 188 - 240V Plug and Receptacle

4. Connect the power cord white and black leads, respectively, to the two "hot" plug blades, and connect the power cord grounding wire to the plug ground prong.
5. Plug the saw into a 240V, 15 AMP, 3-blade receptacle.
6. Make certain the receptacle is connected to a 240V A.C. power supply through a 240V branch circuit having at least a 15 AMP time delay fuse or circuit breaker.

Troubleshooting

⚠ WARNING: To avoid injury turn power switch off and remove plug from power source outlet before troubleshooting.

Electronics

Problem	Probable Cause	What to Do
No display when On/Off button is pressed.	Battery not installed correctly.	Adjust battery position in compartment.
	Battery contacts dirty.	Clean battery contacts.
	Battery dead.	Replace battery with 6V, size J, alkaline battery.
	Indicator display failure.	Contact Sears. Have electronics checked by qualified technician.
Display shows 	Normal display when battery is first installed in unit.	No action required.
	Reference points not set for desired display.	Follow procedure for setting zero reference points in the Setting Electronic Display section.
	Poor battery contact to indicator display leads causing intermittent power to display.	Clean battery contacts. Adjust battery position in compartment.
	Indicator display failure.	Contact Sears. Have electronics checked by qualified technician.
Display dim.	Low battery voltage.	Replace battery with 6V, size J, alkaline battery.
	Saw very cold.	Allow saw to warm to above 32°F.
Display dark.	Saw very warm.	Allow saw to cool to below 120°F.
Display blanks after a few minutes.	Normal.	Press On/Off button. Display should return.
Display blanks when moving carriage, then re-appears when motion stops.	Normal. Sometimes indicator will not display while blade position is changing rapidly.	No action required.

Electronics - 2

Problem	Probable Cause	What to Do
Display shows EEE.E or EE.EE.	Arm or carriage moved too rapidly for indicator to monitor.	Follow procedure for setting zero reference points in the Setting Electronic Display section.
Display will reset to zero but immediately shows EEE.E or EE.EE when arm or carriage is moved.	Encoder or indicator display defective.	Have electronics checked by qualified technician. Repair service available at nearest Sears Store.
Display does not change when arm or carriage is moved.	Wrong indicator function selected.	Select proper function.
	Encoder or indicator display defective.	Have electronics checked by qualified technician. Repair service available at nearest Sears Store.
Display does not read 0°, or 45° at bevel or miter indexes.	Indicator not set to zero reference at index points.	Follow procedure for setting zero reference points in the Setting Electronic Display section.
	Angle encoder not adjusted.	Follow procedure for adjusting encoders in the Setting Electronic Display section.

Motor

Problem	Probable Cause	What to Do
Motor will not run.	Protector open; circuit broken.	Push red button located on top of motor. Listen for audible click that indicates motor is reset.
	Low voltage.	Check power line for proper voltage.
Motor will not run and fuses blow.	Short circuit in line, cord, or plug.	Inspect line, cord, and plug for damaged insulation and shorted wires.
	Short circuit in motor or loose connections.	Inspect all terminals in motor for loose or shorted terminals or worn insulation wires.
	Incorrect fuses in power line.	Install correct fuses.

Motor - 2

Problem	Probable Cause	What to Do
Motor fails to develop full power. (Power output of motor decreases rapidly with decrease in voltage at motor terminals. For example: a reduction of 10% in voltage causes a reduction of 19% in maximum power output of which the motor is capable, while a reduction of 20% in voltage causes a reduction of 36% in maximum power output.)	Power line overloaded with lights, appliances, and other motors.	Reduce the line load.
	Undersize wires or circuit too long.	Increase wire sizes, or reduce length of wiring.
	General overloading of power company's facilities. (In many sections of the country, demand for electrical power exceeds the capacity of existing generating and distribution systems).	Request a voltage check from power company.
Motor overheats.	Excessive feed rate when crosscutting or ripping.	Slow down rate of feed.
	Improper cooling. (Air circulation restricted through motor due to sawdust, etc.)	Clean out sawdust to provide normal air circulation through motor.
	Saw blade has heel.	Refer to Making Blade Parallel to Table section.
Motor starts slowly or fails to come up to full speed.	Starting switch will not trip due to low voltage.	Correct low voltage condition.
Motor stalls resulting in blown fuses or tripped circuit breakers.	Voltage too low to permit motor to reach operating speed.	Correct the low line voltage condition.
	Fuses or circuit breakers do not have sufficient capacity.	Replace fuses or circuit breakers with proper capacity units.
Frequent opening of fuses or circuit breakers.	Motor overloaded.	Reduce motor load.
	Fuses or circuit breakers do not have sufficient capacity.	Replace fuses or circuit breakers.

Saw Operations

Problem	Probable Cause	What to Do
Crosscuts not accurate at 0° and 45° miter.	Looseness between column tube and column support.	Go to Alignment of the Blade, Adjusting Elevation.
	Crosscut travel not square with fence.	Go to Alignment of the Blade, Squaring Crosscut Travel.
	Column is loose in support.	Go to Alignment of the Blade, Adjusting Elevation.
	Arm not indexing properly.	Go to Maintaining Your Saw, Adjustments for Wear, Miter Lock.
	Carriage assembly loose on arm.	Go to Alignment of the Blade, Squaring Blade to Table for Ripping.
	Looseness between yoke and carriage assembly.	Go to Maintaining Your Saw, Adjustments for Wear, Swivel Lock.
	Sawdust between workpiece and fence.	Keep front table clean.
Fence not straight.	Replace fence.	
Saw cuts at slight bevel (not 90° to table).	Work table not properly leveled.	Go to Alignment of the Blade, Leveling Front Table.
	Blade not square to table.	Go to Alignment of the Blade, Squaring Blade to Table for Crosscutting.
	Carriage Bearings Loose	Go to Alignment of the Blade, Squaring Blade to Table for Ripping.
	Bevel lock loose.	Go to Maintaining Your Saw, Adjustments for Wear, Bevel Lock.

Saw Operations - 2

Problem	Probable Cause	What to Do
Workpiece kerf rough with tooth marks from blade (also called heel).	Saw blade not square to fence.	Go to Alignment of the Blade, Squaring Blade to Fence.
	Saw blade not parallel to table.	Go to Alignment of the Blade, Making Blade Parallel to Table.
	Using improper blade for finish cut desired.	Use proper smooth cutting blade.
Wood binds, smokes, and motor slows down or stops when ripping.	Dull blade or warped board.	Sharpen or replace the saw blade. Do not use severely warped material.
	Feed rate too fast.	Slow feed rate.
	Saw blade heels.	Go to Alignment of the Blade, Making Blade Parallel to Table.
	Fence not straight.	Replace fence.
	Carriage assembly loose on arm.	Go to Alignment of the Blade, Squaring Blade to Table for Ripping.
Board pulls away from fence when ripping.	Saw blade has heel.	Go to Alignment of the Blade, Making Blade Parallel to Table.
Workpiece strikes spreader when ripping.	Spreader not in line with blade.	Go to Alignment of the Blade, Installing Guard / Setting Spreader.
Saw does not travel smoothly on arm.	Dirty track.	Clean track and lubricate with light grease.
	Bad bearing.	Replace bearing.
	Worn track.	Replace track.
Clamping force not sufficient at miter angles other than 45°.	Miter lock needs adjustment.	Go to Maintaining Your Saw, Adjustments for Wear, Miter Lock.

Saw Operations - 3

Problem	Probable Cause	What to Do
Clamping force not sufficient at bevel angles other than 45°.	Bevel lock needs adjusting.	Go to Maintaining Your Saw, Adjustments for Wear, Bevel Lock.
Depth of cut varies from one end of the workpiece to the other.	Table top not parallel with arm.	Go to Alignment of the Blade, Leveling Front Table.
Blade tends to advance through lumber too fast.	Dull blade.	Replace or sharpen blade.
	Not advancing saw properly.	Draw saw blade across lumber with a slow and steady pull.
Table cannot be leveled. (Right side is higher than left side with no adjustment left, or vice versa.)	Column support shifted where it mounts to saw base.	Loosen the six bolts that hold the column support to the saw base and shift arm.

NOTES

Lined area for writing notes, consisting of multiple horizontal lines.

**PARTS LIST FOR CRAFTSMAN 10" ELECTRONIC RADIAL SAW
MODEL NOS. 113.197410 AND 113.197610**

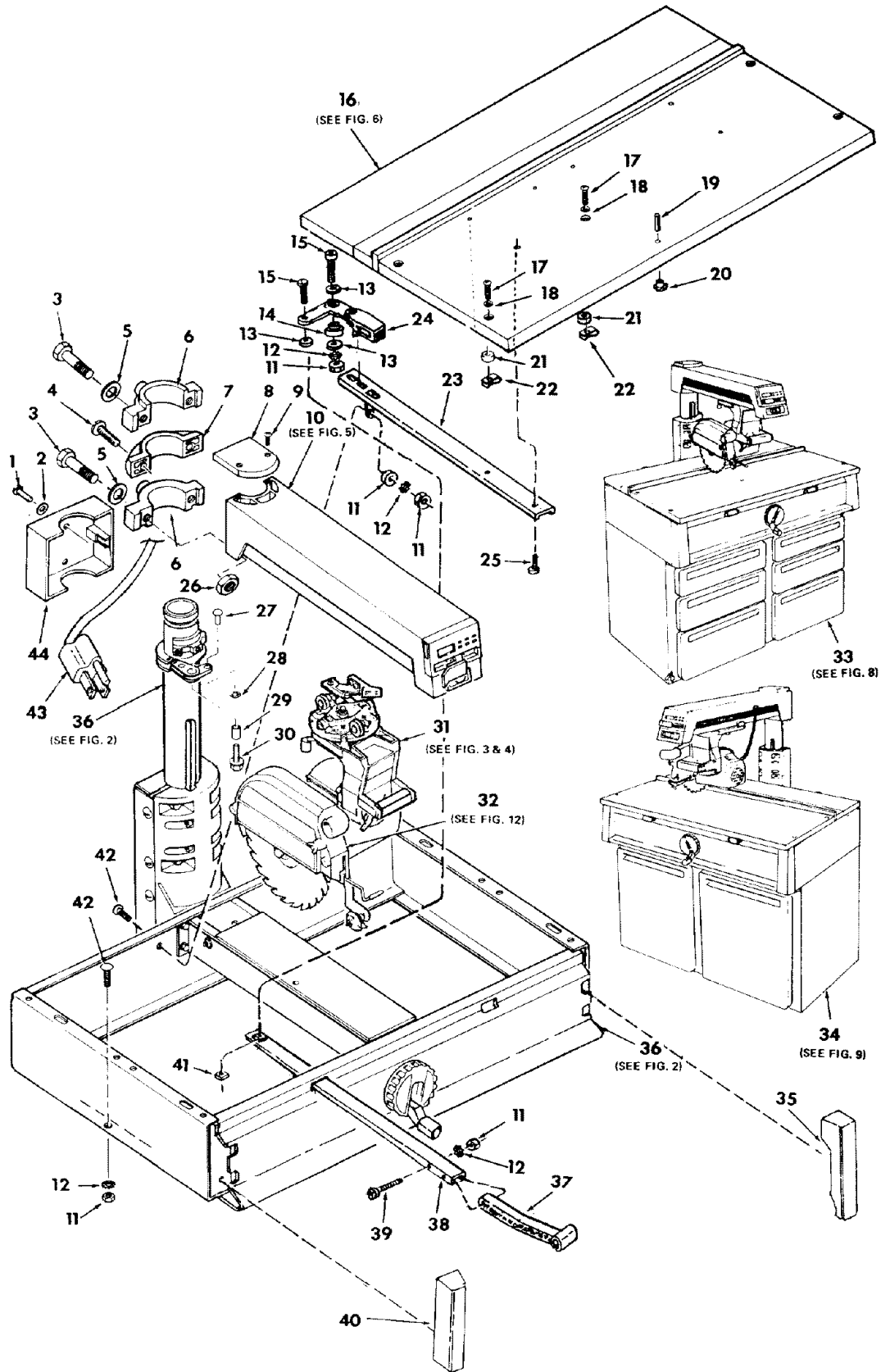

FIGURE 1

**PARTS LIST FOR CRAFTSMAN 10" ELECTRONIC RADIAL SAW
MODEL NOS. 113.197410 AND 113.197610**

Always order by Part Number - Not by Key Number

FIGURE 1

Key No.	Part No.	Description
1	816333-1	Screw, Pan Rec. Type "TT" 10-32 x 1/2
2	STD551010	*Washer, 13/64 x 7/16 x 1/16
3	60339	Bolt, Hex Hd. 3/8-16 x 2-1/8
4	808380-6	Screw, Pan Rec. Hd. Plastite No. 8 x 1
5	60353	*Washer, .380 x 47/64 x 1/8
6	815649	Bearing, Arm
7	815710	Strap
8	815820	Cap, Arm
9	816333	*Screw, Pan Rec. Hd. Type "TT" 10-32 x 7/8
10	—	Arm Assembly (see Fig. 5)
11	STD541025	*Nut, Hex 1/4-20
12	STD551225	*Lockwasher, External 1/4
13	STD551012	*Washer, 17/64 x 9/16 x 3/64
14	818160	Spacer
15	STD512507	*Screw, Pan Cross 1/4-20 x 5/8
16	—	Table Boards Set (see Fig. 6)
17	806828-4	Screw, Pan Cross Ty T 1/4-20 x 1-1/2
18	STD551012	*Washer, 17/64 x 5/8 x 1/32
19	60074	Screw, Hex Socket Set 1/4-20 x 7/8
20	37384	Nut, Tee
21	815762	Bushing, Rubber
22	815989	Clip, "U" 1/4-20
23	818190	Channel, Lock Mounting
24	818181	Slide Assembly, Lock L.H.
—	818180	Slide Assembly, Lock R.H.

Key No.	Part No.	Description
25	815797-1	Screw, Pan Cross Type "AB" 1/4 x 5/8
26	STD541037	*Nut, Hex 3/8-16
27	815774	Rivet 1/4 x 1/2
28	60208	Nut, Push 1/4
29	815980	Bushing
30	815856-1	Screw, Hex Wash Hd. 5/16-18 x 1-1/4
31	—	Yoke and Motor Assembly (see Figs. 3 & 4)
32	—	Guard Assembly (see Fig. 12)
33	—	Cabinet Assembly Model 197610 (see Fig. 8)
34	—	Cabinet Assembly Model 197410 (see Fig. 9)
35	818192	Cap, End R.H.
36	—	Base and Column Assembly (see Fig. 2)
37	816386	Knob, Bevel Lock
38	818200	Actuator, Lock
39	60043	Screw, Pan Cross 1/4-20 x 1-1/8
40	818193	Cap, End L.H.
41	818247	Nut, Square Lock 1/4-20
42	805589-5	Screw, Truss Hd. 1/4-20 x 1/2
43	818173	Cord with Plug
44	815773	Cover, Rear Arm
—	507974	Bag of Loose Parts (Not Ills.)
—	507973	Bag of Loose Parts (Not Ills.)
—	SP5251	Owners Manual (Not Ills.)

*Standard Hardware Item may be Purchased Locally.

**PARTS LIST FOR CRAFTSMAN 10" ELECTRONIC RADIAL SAW
MODEL NOS. 113.197410 AND 113.197610**

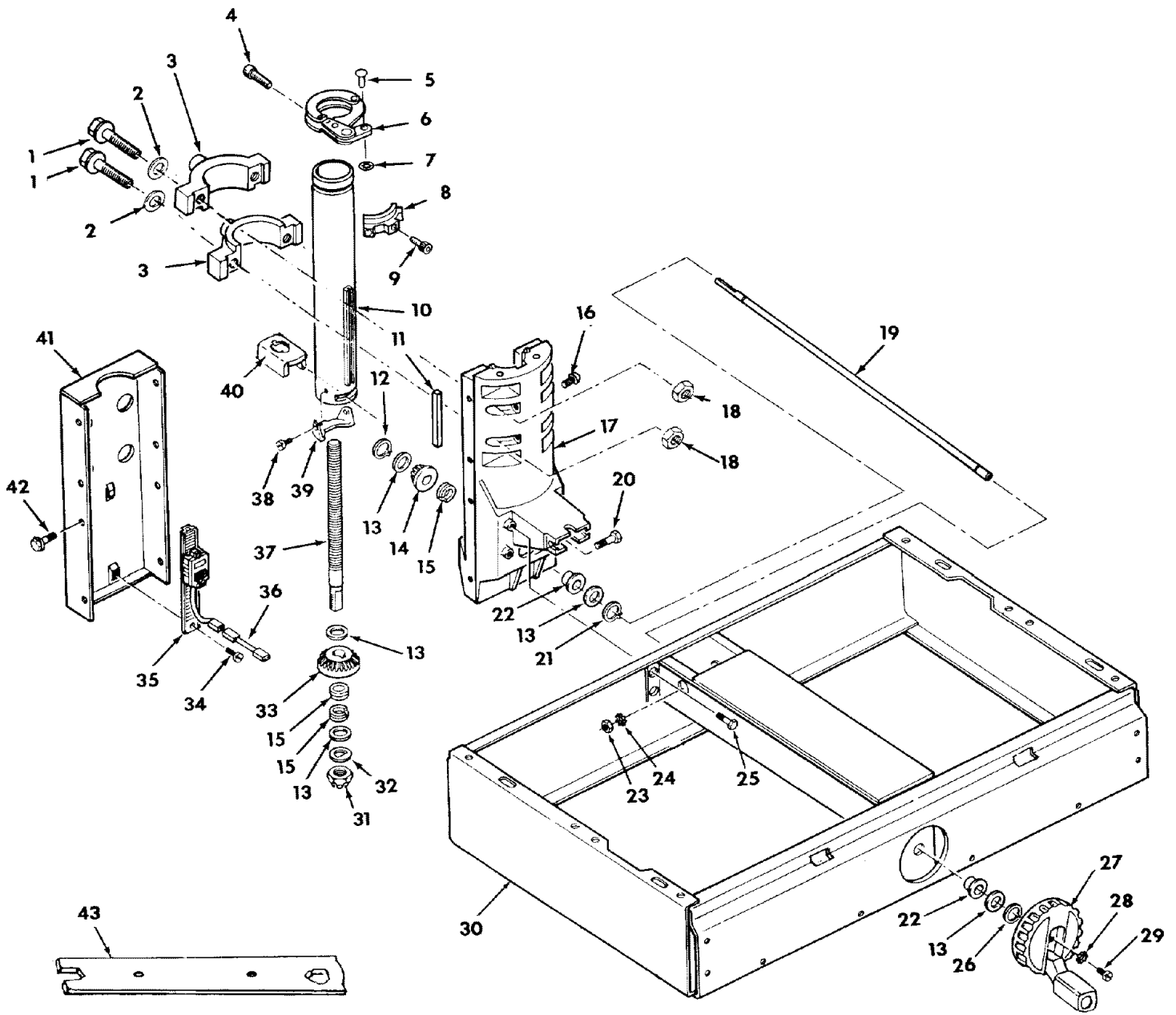

FIGURE 2

**PARTS LIST FOR CRAFTSMAN 10" ELECTRONIC RADIAL SAW
MODEL NOS. 113.197410 AND 113.197610**

Always order by Part Number - Not by Key Number

FIGURE 2 -BASE AND COLUMN ASSEMBLY

Key No.	Part No.	Description
1	60339	Bolt, Hex Washer Hd. 3/8-16 x 2-1/8
2	60353	Washer, .380 x 47/64 x 1/8
3	815649	Bearing, Arm
4	817398-2	*Screw, Socket Hd. Cap 1/4-20 x 1-1/4
5	815774	Rivet, 1/4 x 1/2
6	818198	Lock Assembly
7	60208	Nut, Push 1/4
8	815763	Latch, Arm
9	816647	Screw, Soc. Hd. Ty "T" 1/4-20 x 3/4
10	816647	Tube
11	815770	Gib, Column Tube
12	STD581043	*Ring, Retaining 7/16
13	63500	Washer, Thrust .502 x .927 x .031
14	818165	Gear, Pinion
15	63614	Bearing Lift Shaft
16	817398-1	Screw, Locking Cap 1/4-20 x 5/8
17	818212	Support, Column Tube
18	STD541037	*Nut, Hex 3/8-16
19	818177	Shaft, Elevating Crank
20	STD523107	*Screw, Hex Hd. 5/16-18 x 3/4
21	STD582050	*Ring, Retaining 1/2

Key No.	Part No.	Description
22	815772	Bushing Elevation
23	STD541031	*Nut, Hex 5/16-18
24	STD551131	Lockwasher, External 5/16
25	9416187	Screw, Hex Hd. Ty "T" 5/16-18 x 3/4
26	804182	Ring, Retaining
27	818237	Handwheel
28	STD551210	*Lockwasher, External #10
29	STD511105	*Screw, Pan Hd. 10-32 x 1/2
30	818216	Base Assembly
31	STD541450	*Nut, Lock 1/2-13
32	817106	Washer, Keyed
33	818164	Gear, Bevel
34	STD610803	*Screw, Pan Rec. Hd. Type "AB" #8 x 3/8
35	815749-1	Encoder, Elevation
36	817022	Cord, Elevation
37	818167	Shaft, Elevating
38	STD601103	*Screw, Pan Rec. Hd. Type "T" 10-32 x 3/8
39	815826	Actuator, Elevation
40	818224	Nut, Elevation
41	815864	Cover, Column Support
42	815865	Screw, Hex Washer Hd. Type "T" 1/4-20 x 1/2
43	3540	Wrench

*Standard Hardware Item may be Purchased Locally.

**PARTS LIST FOR CRAFTSMAN 10" ELECTRONIC RADIAL SAW
MODEL NOS. 113.197410 AND 113.197610**

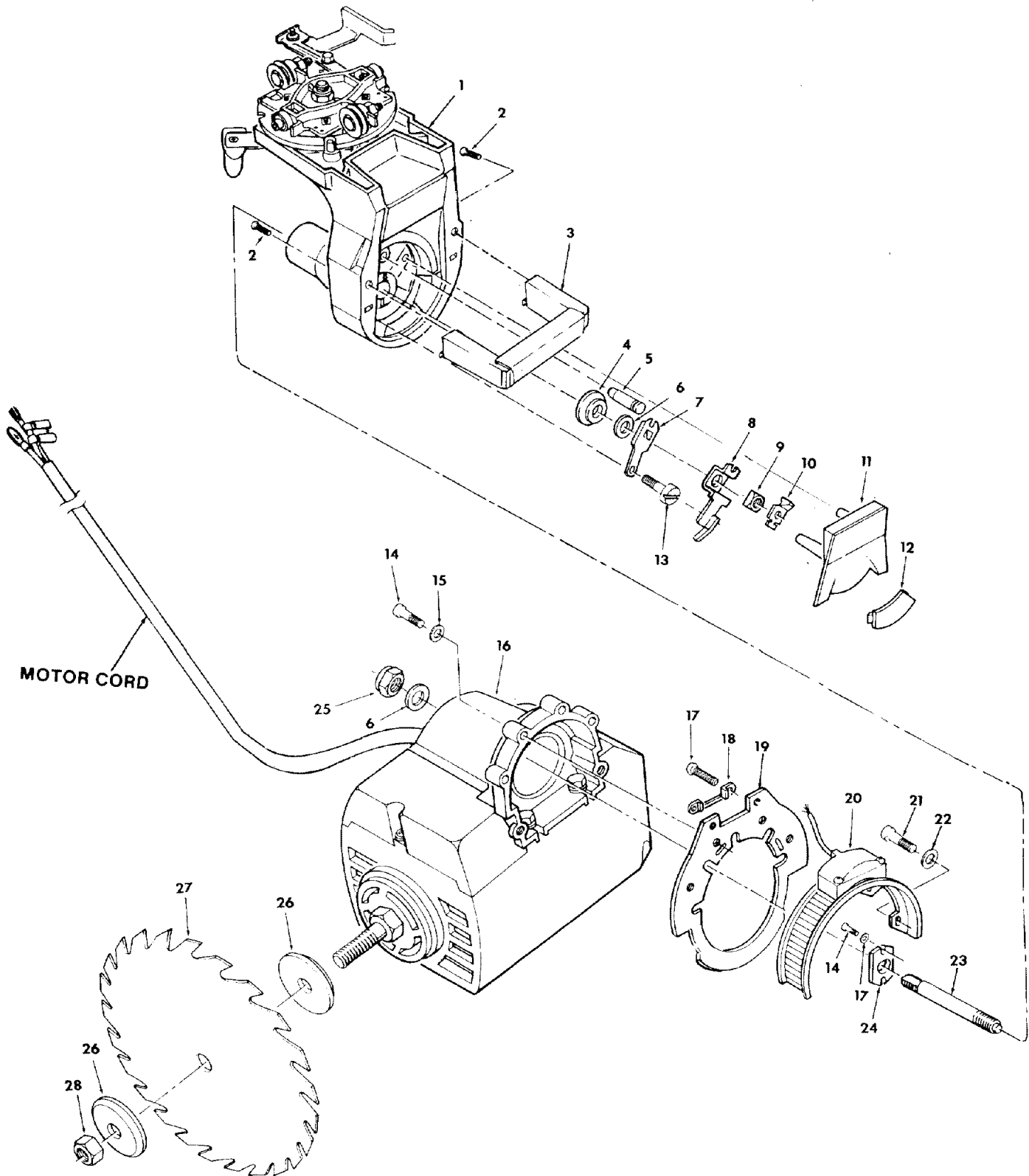

FIGURE 3

**PARTS LIST FOR CRAFTSMAN 10" ELECTRONIC RADIAL SAW
MODEL NOS. 113.197410 AND 113.197610**

Always order by Part Number - Not by Key Number

FIGURE 3 - YOKE AND MOTOR ASSEMBLY

Key No.	Part No.	Description
1	—	Yoke Assembly (see Figure 4)
2	818922	Screw, Flat Hd., Plastite No. 8 x 1
3	818202	Handle, Yoke
4	815678	Washer, Shaft
5	815679-1	Pin, Index
6	805561-10	Washer, .505 x 7/8 x 1/16
7	815791	Spring, Bevel
8	818154	Lever, Bevel Lock
9	815813	Nut, Square 1/2-13
10	815836	Wedge, Bevel Spring
11	818204	Cover, Yoke
12	815799	Plug, Yoke
13	806828	Screw, Pan Hd. Type "T" 1/4-20 x 1/2
14	815992	Screw, Soc. Hd. Type "TT" 1/4-20 x 5/8

Key No.	Part No.	Description
15	STD551012	*Washer, 17/64 x 9/16 x 1/16
16	818888	•Motor (Complete) (See Fig. 5)
17	STD510802	*Screw, Pan Hd. Type "T" 8-32 x 5/16
18	815802	Guide, Bevel Reader
19	818197	Plate, Index
20	815751	Encoder, Bevel
21	STD601103	*Screw, Hex Washer Hd. Type "T" 10-32 x 1/2
22	STD551010	*Washer, 3/16 x 3/8 x 1/32
23	818153	Shaft, Support
24	818152	Plate, Adjustment
25	805839-1	Nut, Lock 1/2-13
26	62498	Collar, Blade
27	9-32668	†Blade, Saw
28	30495	Nut, Shaft

*Standard Hardware Item may be Purchased Locally.

†Stock Item may be secured Through the Hardware Department of Most Sears Retail or Catalog Order Houses.

•Any attempt to repair this motor may result in unit misalignment and create a HAZARD unless repair is done by a qualified service technician. Do not loosen the three screws holding the motor support to the motor. This assembly is factory aligned. Repair service is available at your nearest Sears Store.

**PARTS LIST FOR CRAFTSMAN 10" ELECTRONIC RADIAL SAW
MODEL NOS. 113.197410 AND 113.197610**

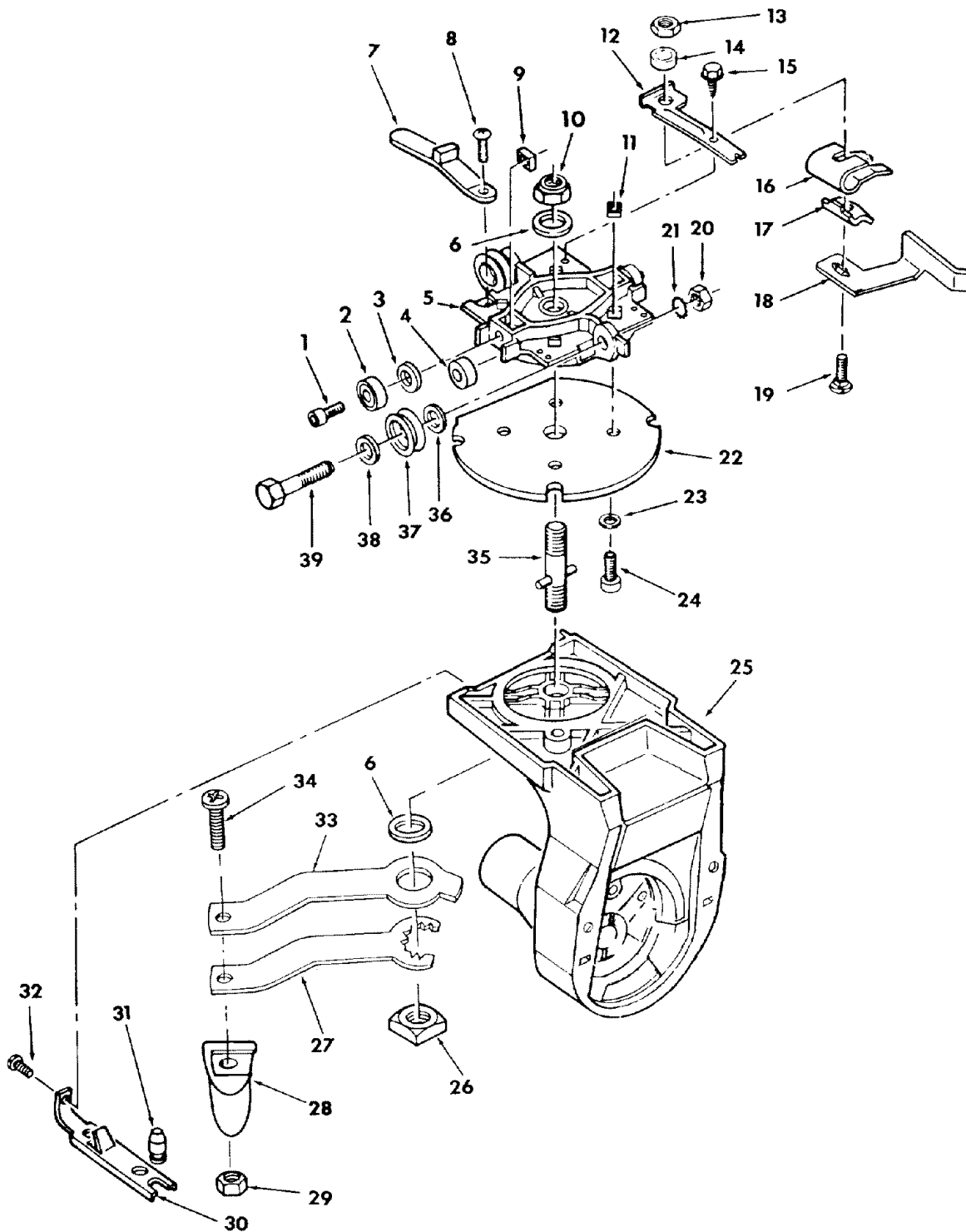

FIGURE 4

**PARTS LIST FOR CRAFTSMAN 10" ELECTRONIC RADIAL SAW
MODEL NOS. 113.197410 AND 113.197610**

Always order by Part Number—Not by Key Number

FIGURE 4 —YOKE ASSEMBLY

Key No.	Part No.	Description
1	810214-3	Screw, Low Hd. Cap 5/16-18 x 7/8
2	STD315485	*Bearing, Ball .3150 I.D.
3	STD551031	*Washer, 21/64 x 5/8 x 1/32
4	817181	Wiper, Track
5	815689	Carriage
6	STD551062	*Washer, .360 x 1-1/8 x 3/32
7	815827	Actuator, Rip
8	STD600803	*Screw, Pan Rec. Hd. Type "T" 8-32 x 3/8
9	815817	Nut, Square Lock
10	STD541462	*Nut, Lock 5/8-11
11	62636	Nut, Square 1/4-20
12	815693	Bracket, Rip Lock
13	STD541425	*Nut, Lock 1/4-20
14	62520	Spacer
15	273229	Screw, Hex Hd. Type "T" 1/4-20 x 1/2
16	816497	Spring, Rip Lock
17	815671	Cam, Rip Lock
18	818155	Lever, Rip Lock
19	STD532510	*Bolt, Carriage 1/4-20 x 1
20	STD541231	*Nut, Hex Jam 5/16-18

Key No.	Part No.	Description
21	STD551131	*Lockwasher, External 5/16
22	815691	Ring, Yoke Index
23	STD551012	*Washer, 17/64 x 7/16 x 1/32
24	817398-1	Screw, Cap Locking, 1/4-20 x 5/8
25	818207	Yoke
26	109529	Nut, Square 5/8-11
27	818194	Wrench, Adjustment
28	816988	Knob, Swivel
29	STD541025	*Nut, Hex 1/4-20
30	815680	Spring, Swivel
31	815679	Pin Index
32	806828	Screw, Pan Hd. Type "T" 1/4-20 x 1/2
33	818195	Actuator, Swivel
34	STD512515	*Screw, Pan Hd. 1/4-20 x 1-1/2
35	815694	Stud, Yoke Clamp
36	STD551031	*Washer, 21/64 x 3/4 x 1/16
37	63777	Bearing, Carriage
38	60438	Washer, No. 2 Carriage Bearing
39	815807	Screw, Eccentric

* Standard Hardware Item may be Purchased Locally.

**PARTS LIST FOR CRAFTSMAN 10" ELECTRONIC RADIAL SAW
MODEL NOS. 113.197410 and 113.197610**

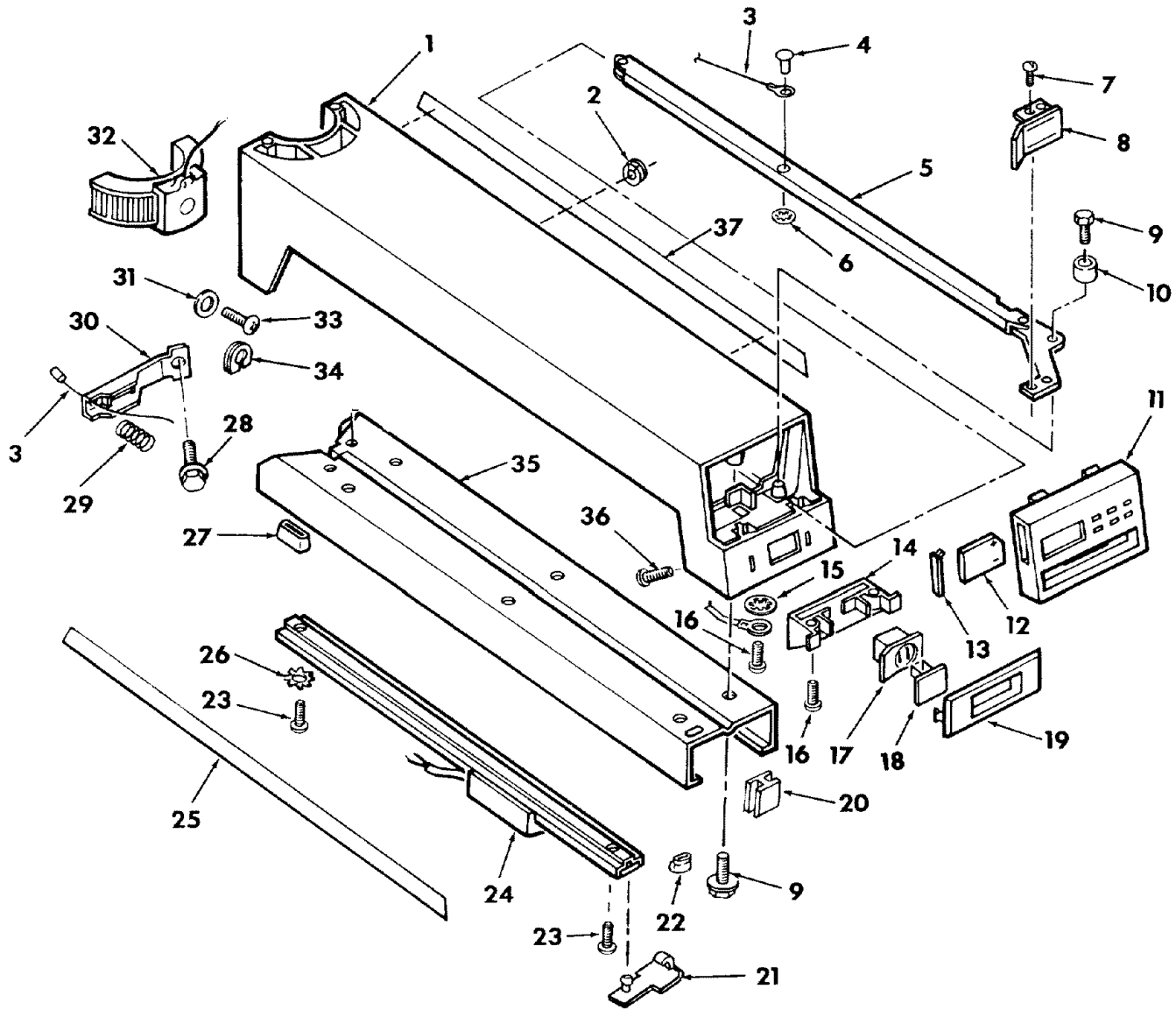

FIGURE 5

**PARTS LIST FOR CRAFTSMAN 10" ELECTRONIC RADIAL SAW
MODEL NOS. 113.197410 and 113.197610**

Always order by Part Number - Not by Key Number

FIGURE 5 - ARM ASSEMBLY FOR MODEL 113.197410

Key No.	Part No.	Description
1	818239	Arm, Radial
2	818537	Relief, Strain
3	815809	Cable
4	815774	Rivet, 1/4 x 1/2
5	818182	Actuator Assembly
6	60208	Push Nut, 1/4
7	STD601103	*Screw, Pan Rec. Type "T" 10-32 x 3/8
8	815703	Knob, Miter Lock
9	815856	Screw, Hex Washer Hd. 5/16-18 x 3/4
10	815779	Bushing
11	815741	Controls, R.S.
12	STD363539	•Battery
13	815735	Lid, Battery Access
14	815704	Housing, Switch
15	STD551208	*Lockwasher, Internal #8
16	STD600803	*Screw, Pan Rec. Hd. Type "T" #8-32 x 3/8
17	815775	Switch, Locking
18	9-22256	†Key, Switch
19	815976	Bezel, Switch
20	818521	Bumper, Rubber

Key No.	Part No.	Description
21	816492	Clip, Wire
22	815789	Strain, Relief
23	816333-3	*Screw, Pan Rec. Hd. Type "TT" #10-32 x 5/8
24	816490	Encoder, Rip (Includes Key #22)
25	815784	Label, Trim L.H.
26	STD551210	*Lockwasher, External #10
27	816178	Sleeve, Rubber
28	815856	Screw, Hex Washer Hd. 5/16-18 x 3/4
29	815867	Spring, Compression
30	815708	Spring, Miter Lock
31	STD551010	*Washer 13/64 x 5/8 x 1/32
32	815752	Encoder Miter
33	808380-10	Screw, Pan Rec. Hd. Plastite #10-14 x 3/8
34	815868	Relief, Strain
35	818088-1	Track, Arm
36	346030	Screw, Pan Rec. Hd. #8-10 x 1/2
37	818536	Label, Trim R.H.

*Standard Hardware Item may be Purchased Locally.

†

•Can also use these battery numbers:

Eveready #539

Rayovac #867

Duracel #7K67

**PARTS LIST FOR CRAFTSMAN 10" ELECTRONIC RADIAL SAW
MODEL NOS. 113.197410 AND 113.197610**

Always order by Part Number - Not by Key Number

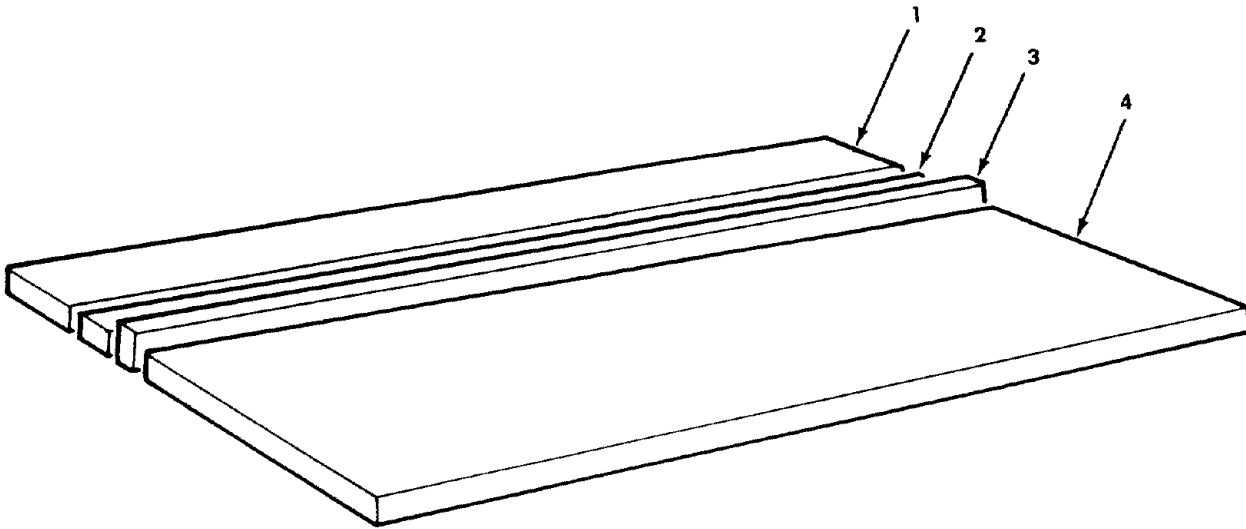

FIGURE 6 - TABLE ASSEMBLY

Key No.	Part No.	Description
1	815757	Table, Rear
2	815755	Table, Spacer
3	815758	Fence, Rip
4	818196-1	Table, Front

*Standard Hardware Item may be Purchased Locally.

**PARTS LIST FOR CRAFTSMAN 10" ELECTRONIC RADIAL SAW
MODEL NOS. 113.197410 AND 113.197610**

Always order by Part Number - Not by Key Number

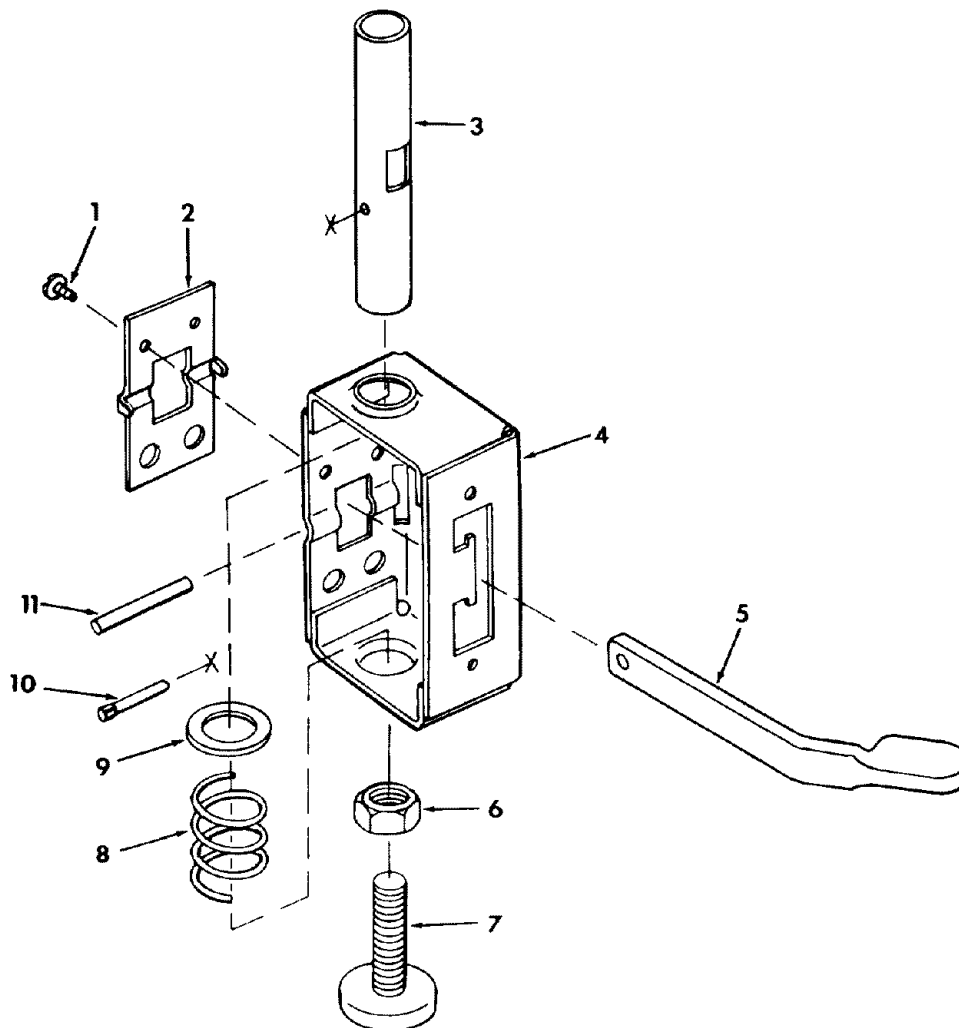

FIGURE 7 - FOOT ASSEMBLY - MODEL 113.197610

Key No.	Part No.	Description
1	STD601103	*Screw, Pan Rec. Hd. Type T 10-32 x 3/8
2	815874	Retainer, Pin
3	817116	Rod Assembly, Foot
4	815879	Support
5	815871	Actuator, Foot
6	STD541237	*Nut, Hex Jam 3/8-16
7	803835-1	Foot, Leveling
8	815878	Spring
9	815875	Washer
10	803927-3	Pin, Groove
11	808503-1	Pin
—	507799	Bag of Loose Parts (Not Ills.)

*Standard Hardware Item may be Purchased Locally.

**PARTS LIST FOR CRAFTSMAN 10" ELECTRONIC RADIAL SAW
MODEL NOS. 113.197410 AND 113.197610**

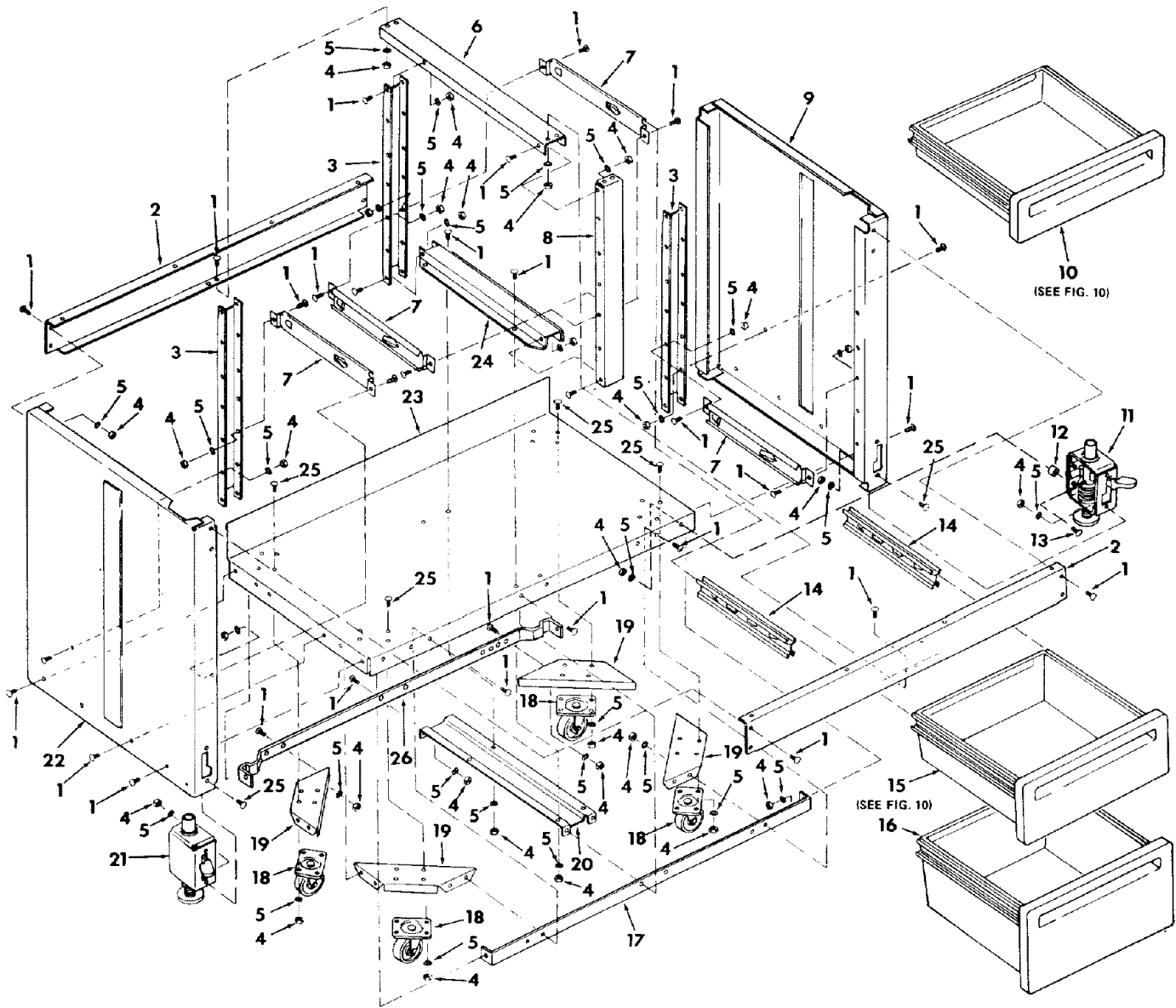

Figure 8

**PARTS LIST FOR CRAFTSMAN 10" ELECTRONIC RADIAL SAW
MODEL NOS. 113.197410 AND 113.197610**

Always order by Part Number - Not by Key Number

FIGURE 8 - CABINET ASSEMBLY FOR MODEL 113.197610

Key No.	Part No.	Description
1	805589-5	Screw, Truss Hd. 1/4-20 x 1/2
2	815898	Skirt 44"
3	815892	Support, Center Rear
4	STD541025	*Nut, Hex 1/4-20
5	STD551225	*Lockwasher, External 1/4
6	815893	Support, Upper
7	815890	Bracket, Stand Slide
8	815886	Support, Front Center
9	817151	Panel, Side R.H.
10	—	Drawer Assembly, 3 in. (see Fig. 10)
11	—	Foot Assembly, R.H. (see Fig. 7)
12	802392-36	Spacer
13	805529-5	Screw, Truss Hd. 1/4-20 x 1
14	815888	Bracket, Center Slide

Key No.	Part No.	Description
15	—	Drawer Assembly 6 in. (see Fig. 10)
16	—	Drawer Assembly 10 in. (see Fig. 10)
17	815942	Stiffener, Shelf
18	815896	Caster
19	815993	Support, Caster
20	815991	Support, Under
21	—	Foot Assembly, L.H. (see Fig. 7)
22	817150	Panel, Side L.H.
23	815889	Shelf, Lower 44 in.
24	815891	Support, Lower
25	805529-4	Screw, Slotted Truss Hd. 1/4-20 x 7/16
26	816336	Stiffener - Shelf Rear
—	507802	Bag of Loose Parts (Not Ills.)
—	508172	Bag of Loose Parts (Not Ills.)

*Standard Hardware Item may be Purchased Locally.

**PARTS LIST FOR CRAFTSMAN 10" ELECTRONIC RADIAL SAW
MODEL NOS. 113.197410 AND 113.197610**

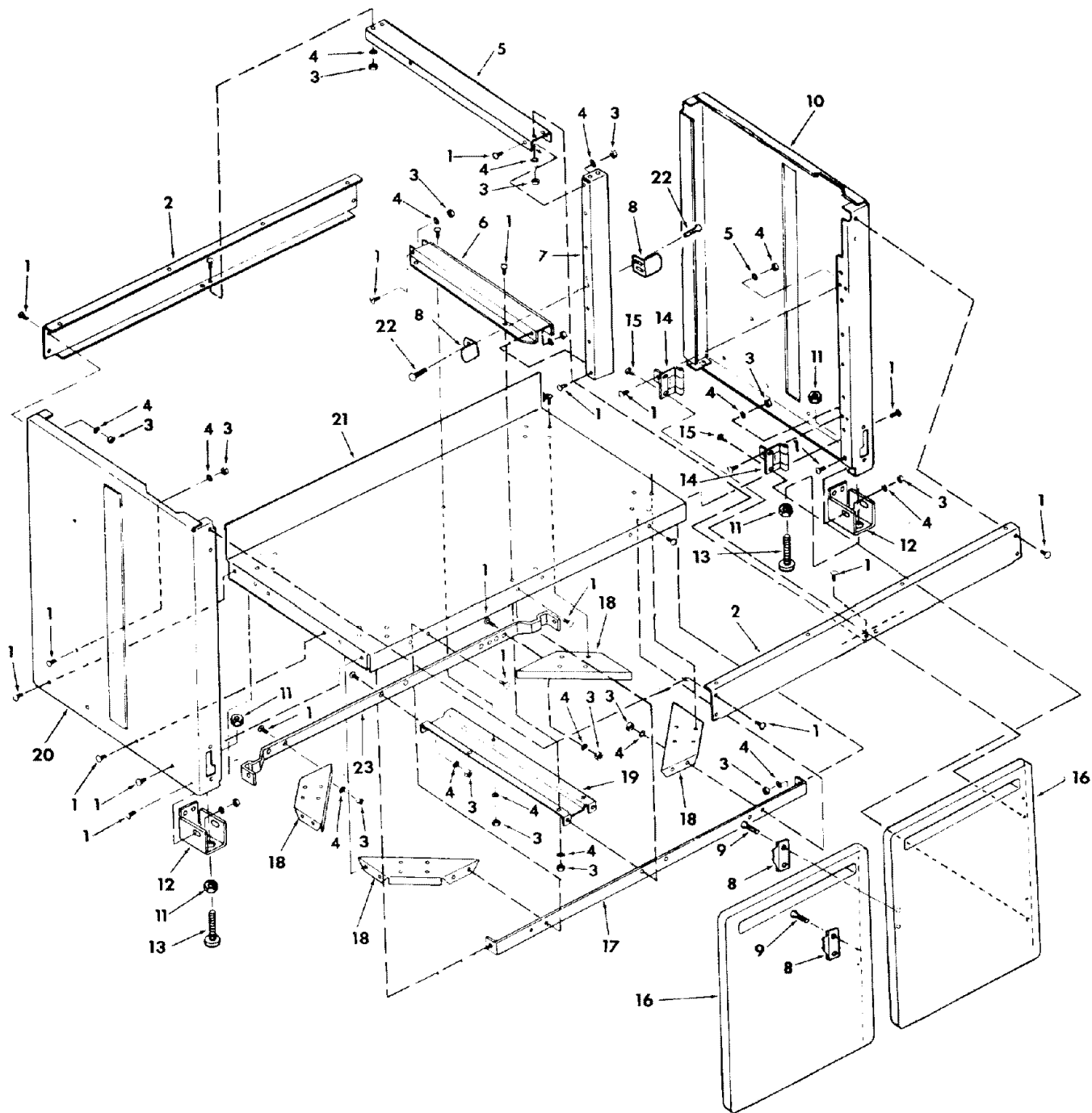

Figure 9

**PARTS LIST FOR CRAFTSMAN 10" ELECTRONIC RADIAL SAW
MODEL NOS. 113.197410 AND 113.197610**

Always order by Part Number - Not by Key Number

FIGURE 9 - CABINET ASSEMBLY FOR MODEL 113.197410

Key No.	Part No.	Description
1	805589-5	Screw, Truss Hd., 1/4-20 x 1/2
2	815898	Skirt
3	STD541025	*Nut, Hex 1/4-20
4	STD551225	*Lockwasher, External 1/4
5	815893	Support, Upper
6	815891	Support, Lower
7	815886	Support, Front Center
8	815933	Catch, Magnetic
9	816274	Screw, Pan Hd. Plastite 6-10 x 1/2
10	817151	Panel, R.H. Side
11	STD541237	*Nut, Hex Jam 3/8-16
12	817108	Spacer
13	803835-1	Foot, Leveling

Key No.	Part No.	Description
14	815934	Hinge, Door
15	816274-1	Screw, Pan Hd. Plastite 10-10 x 1/2
16	815882	Door, Cabinet
17	815942	Stiffener, Shelf
18	815993	Support, Caster
19	815991	Support, Under
20	817150	Panel, L.H. Side
21	815889	Shelf, Lower
22	STD600603	*Screw, Pan Hd. Type "T" 6-32 x 3/8
23	816336	Stiffener - Shelf Rear
—	507533	Bag of Loose Parts (Not Ills.)
—	507976	Bag of Loose Parts (Not Ills.)

*Standard Hardware Item may be Purchased Locally.

**PARTS LIST FOR CRAFTSMAN 10" ELECTRONIC RADIAL SAW
MODEL NOS. 113.197410 AND 113.197610**

Always order by Part Number - Not by Key Number

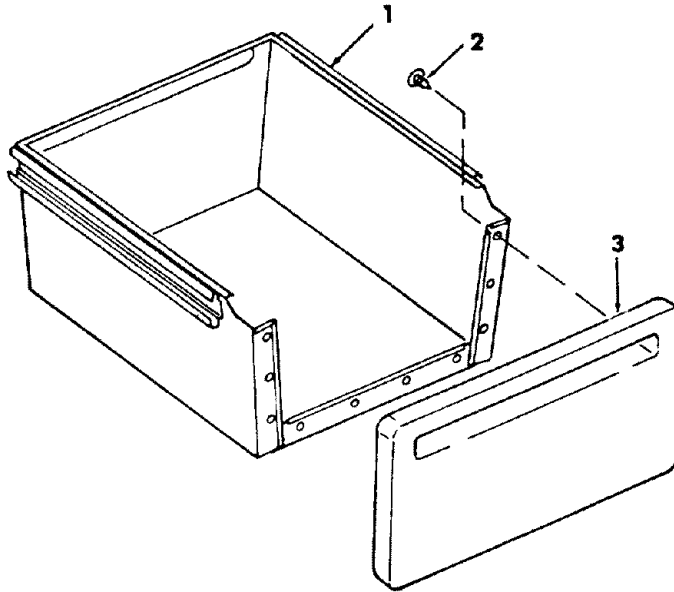

FIGURE 10 - DRAWER ASSEMBLIES 3", 6", 10"

Key No.	Part No.	Description
1	815912	Drawer Assembly, 3"
	815917	Drawer Assembly, 6"
	815919	Drawer Assembly, 10"
2	330751	Fastener
3	815923	Drawer Front, 3"
	815901	Drawer Front, 6"
	815902	Drawer Front, 10"

*Standard Hardware Item may be Purchased Locally.

**PARTS LIST FOR CRAFTSMAN 10" ELECTRONIC RADIAL SAW
MODEL NOS. 113.197410 AND 113.197610**

Always order by Part Number - Not by Key Number

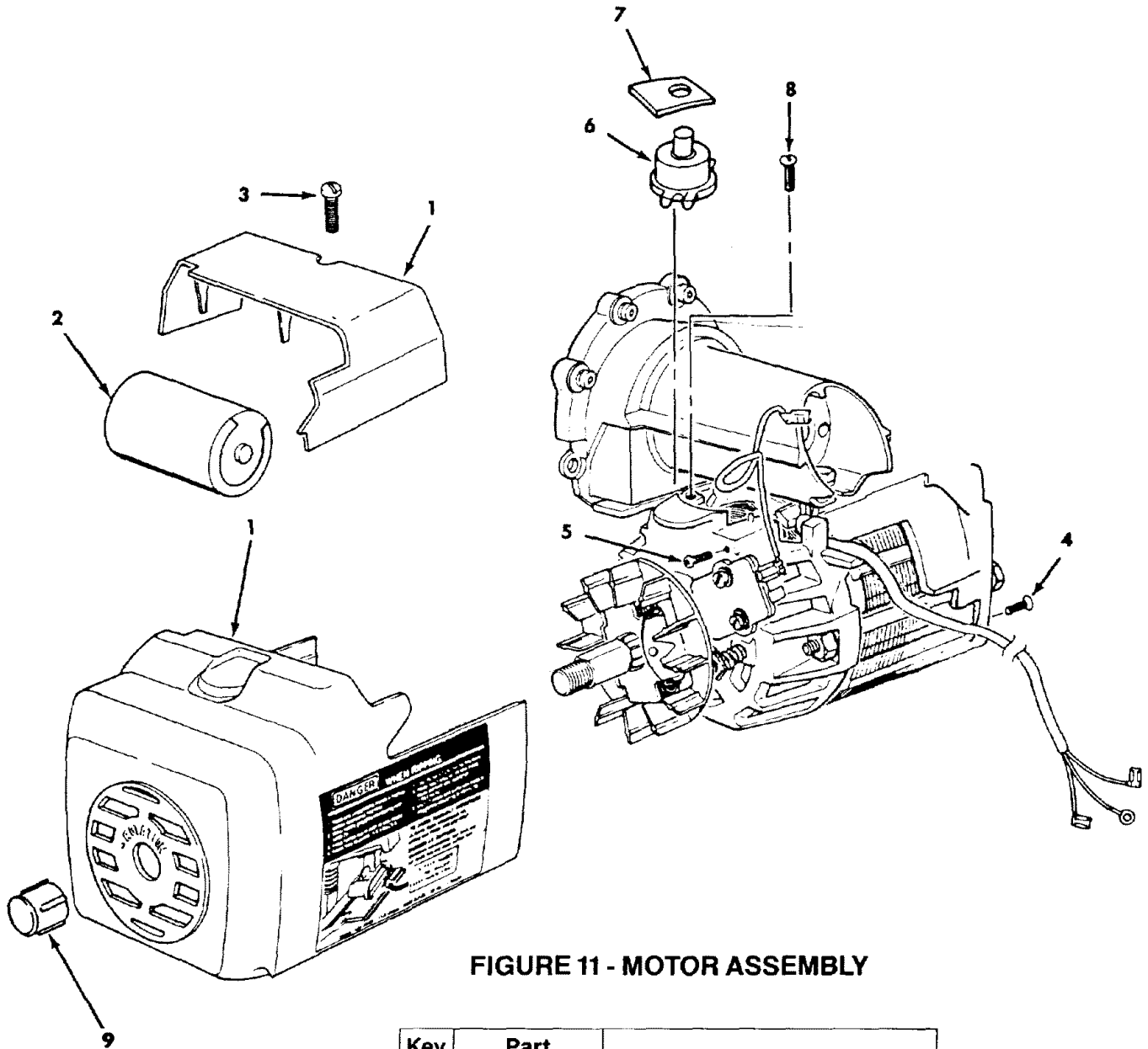

FIGURE 11 - MOTOR ASSEMBLY

Key No.	Part No.	Description
1	507744	Housing, Motor
2	STD376116	*Capacitor
3	64950	Screw, Type "T"
4	64951	Screw, Flat Head
5	64948	Screw, Ground
6	64921	Protector
7	64922	Gasket
8	STD600603	*Screw, Type 23 Pan Hd. 6-32 x 3/8
9	30582	Cap, Shaft

* Standard Hardware Item may be Purchased Locally.

**PARTS LIST FOR CRAFTSMAN 10" ELECTRONIC RADIAL SAW
MODEL NOS. 113.197410 AND 113.197610**

Always order by Part Number - Not by Key Number

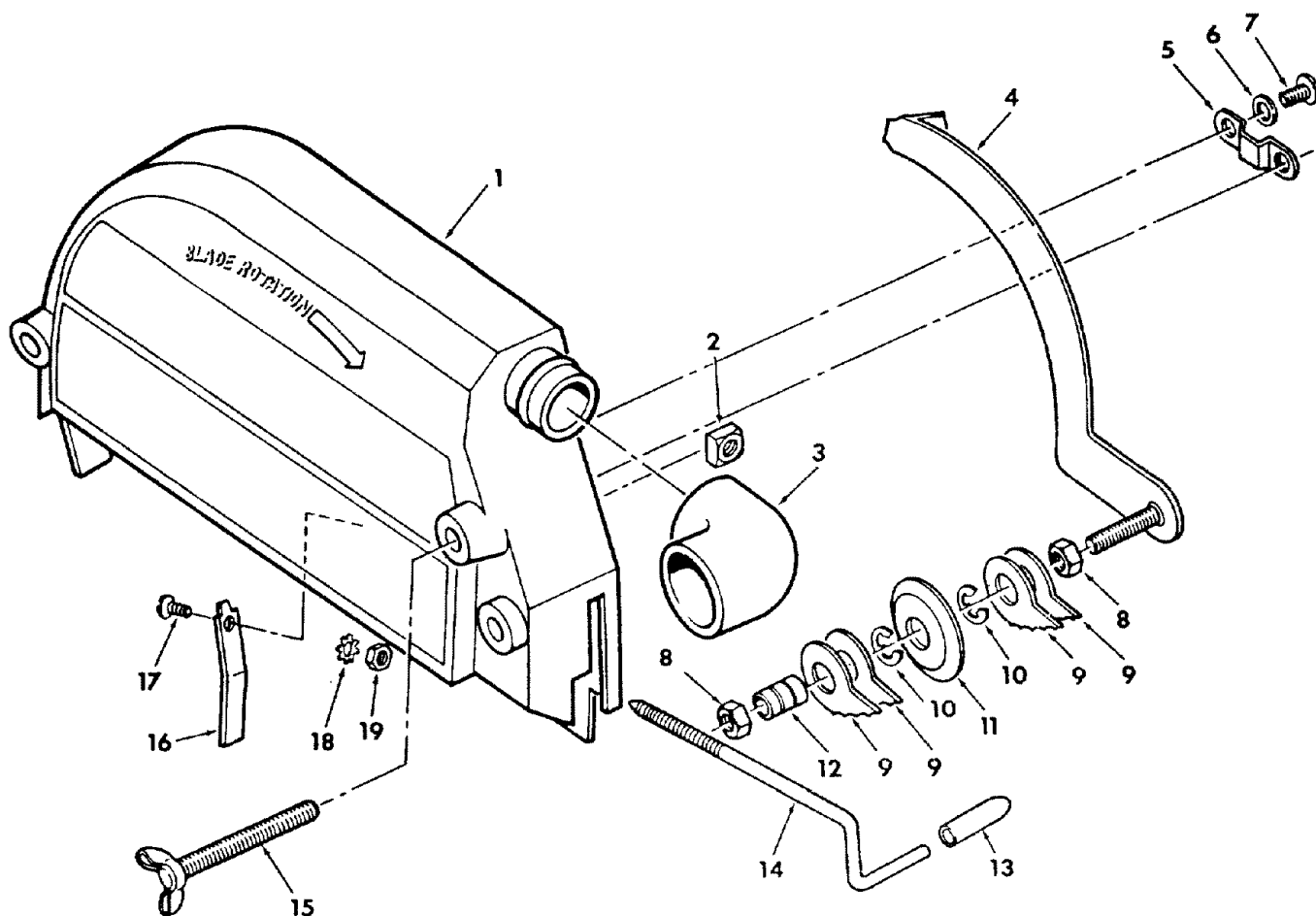

FIGURE 12 - GUARD ASSEMBLY

Key No.	Part No.	Description
1	816264-1	Guard
2	120399	*Nut, Square 5/16-18
3	63258	Elbow, Dust
4	63541	Bar, Anti-Kickback
5	815816	Guide, Anti-Kickback
6	STD551010	*Washer, 13/64 x 5/8 x 1/32
7	STD601103	*Screw, Pan Hd. Type "T" 10-32 x 3/8
8	STD541231	*Nut, Hex Jam 5/6-18
9	815815	Pawl

Key No.	Part No.	Description
10	STD581050	*Ring, Retaining
11	63270	Spreader
12	816341	Bearing (Includes Key #10)
13	60435	Grip
14	816070	Screw, Guard Clamp
15	166785-3	Screw, Wing 5/16-18 x 2-3/4
16	63538	Clamp, Guard
17	STD510805	*Screw, Pan Hd. 8-32 x 1/2
18	STD551208	*Lockwasher, External No. 8
19	STD541008	*Nut, Hex 8-32

*Standard Hardware Item may be Purchased Locally.

SEARS

Operators Manual

SERVICE

MODEL NO.
113.197410

10" DELUXE ELECTRONIC
RADIAL SAW WITH
44" CABINET AND
2 DOORS

or

113.197610

10" DELUXE ELECTRONIC
RADIAL SAW WITH
44" CABINET AND
6 DRAWERS

HOW TO ORDER REPAIR PARTS

10-INCH DELUXE ELECTRONIC RADIAL SAW

Now that you have purchased your 10-inch electronic radial saw, should a need ever exist for repair parts or service, simply contact any Sears Service Center and most Sears, Roebuck and Co. stores. Be sure to provide all pertinent facts when you call or visit.

The model number of your 10-inch electronic radial saw will be found on a plate attached to your saw, at the left-hand side of the base.

WHEN ORDERING REPAIR PARTS, ALWAYS GIVE THE FOLLOWING INFORMATION:

PART NUMBER

PART DESCRIPTION

MODEL NUMBER

NAME OF ITEM

113.197410

DELUXE ELECTRONIC

OR

10-INCH RADIAL SAW

113.197610

All parts listed may be ordered from any Sears Service Center and most Sears stores. If the parts you need are not stocked locally, your order will be electronically transmitted to a Sears Repair Parts Distribution Center for handling.

Sold by SEARS, ROEBUCK AND CO., Chicago, IL. 60684 U.S.A.