

SEARS Kenmore

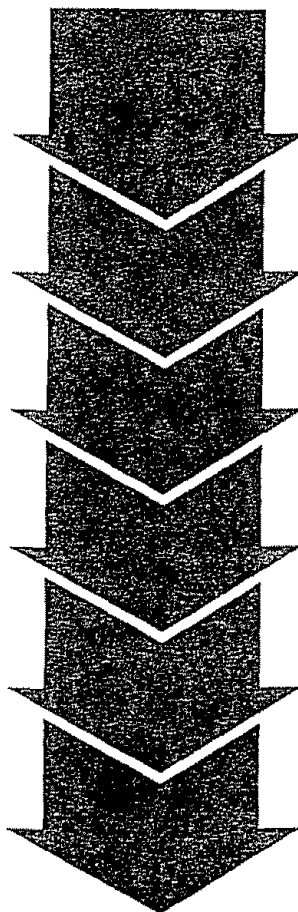

CONTENTS

SAFETY

1-5

PRECAUTIONS: AVOIDING POSSIBLE EXPOSURE TO MICROWAVE ENERGY

4

FEATURES OF YOUR OVEN

6

MICROWAVE OVEN

| | |
|--|----------------|
| Control | 7 |
| Timer, Using a Hold Time | 8 |
| To Time Defrost, Hold and Cook | 8 |
| Microwave Time Cooking | 9 |
| Defrosting by Time, Auto Defrost, Stand Time | 10 |
| Conversion Guide, Auto Defrost Guide | 11 |
| Temperature Cooking, Temperature Probe | 12 |
| Auto Roast, Auto Simmering | 13 |
| Auto Cook, Auto Cooking Control Guide | 13, 14, 15, 16 |
| Microwave Oven Shelf | 17, 19 |

LOWER OVEN

| | |
|--------------------------------|--------|
| Control, Clock and Timer | 20, 21 |
| Bake, Delay Bake and Hold Mode | 21, 22 |
| Broiling | 23 |
| Self-Clean Cycle | 24, 25 |
| Cleaning Tips | 26, 27 |

REMOVABLE PARTS

28, 29

| | |
|---------------------------|----|
| Removal of Packaging Tape | 29 |
|---------------------------|----|

BEFORE CALLING FOR SERVICE

30-32

| | |
|------------------------|----|
| Thermostat Adjustments | 33 |
|------------------------|----|

MODELS 49425, 49429

USE • CARE • SAFETY MANUAL



MNM085-7 SR10015

IMPORTANT IMPORTANT IMPORTANT IMPORTANT IMPORTANT IMPORTANT IMPORTANT IMPORTANT

IMPORTANT INSTRUCTIONS FOR YOUR SAFETY

SAVE THESE INSTRUCTIONS

Read all instructions before using this appliance. When using electrical appliances, basic safety precautions should be followed, including the following:

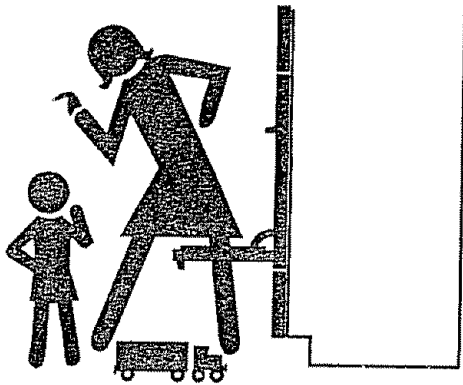

Teach children not to play with oven knobs or any other part of the oven.

Never leave children alone or unattended where an oven is in use.

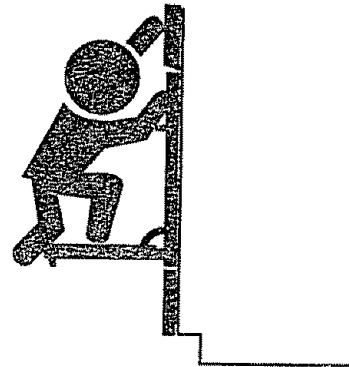

Never store things children might want above an oven.

Never let anyone climb, sit or stand on the open door or any other part of the oven.

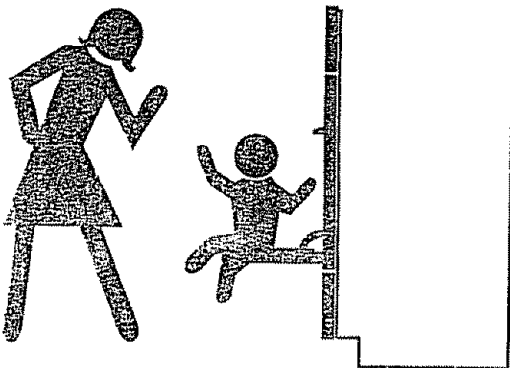

Never leave the oven door open when you are not watching the oven.

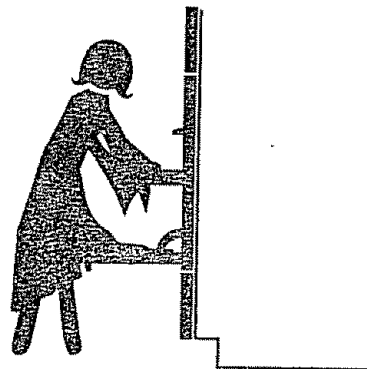

Never wear loose clothing when using your oven. Such clothing could catch fire.

IMPORTANT IMPORTANT IMPORTANT IMPORTANT IMPORTANT IMPORTANT IMPORTANT IMPORTANT IMPORTANT IMPORTANT

To insure safety for yourself and your home, please read your Owner's Manual carefully. Keep it handy for quick easy reference. Pay close attention to the safety sections of your manual. You can recognize the safety sections by looking for the  symbol or the word "Safety".

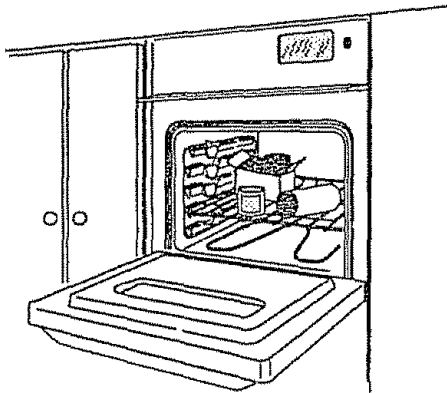

Always keep the oven area clear and free from things that will burn.

CAUTION:

Never store things in an oven. These things may catch fire and plastic items could melt.

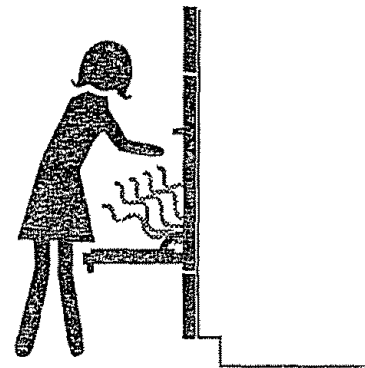

Never use your oven for warming or heating a room. You could be burned or seriously injured. Such misuse could also cause damage to the oven.

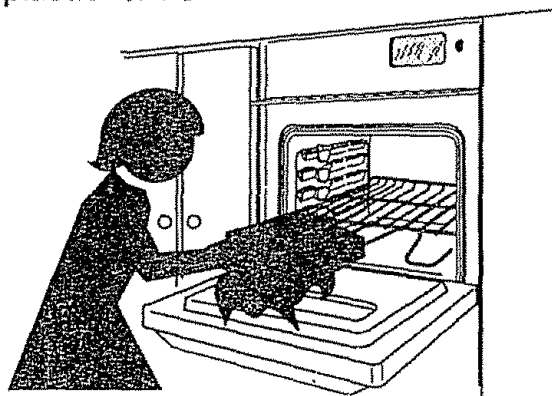

Never use a towel or other bulky cloth as a potholder. Such cloths could catch fire on a hot element.

IMPORTANT SAFETY INSTRUCTIONS

Read all instructions BEFORE using this appliance.

When using electrical appliances, basic safety precautions should be followed, including the following:

Always use this appliance only for its intended use as described in this manual.

Be sure your appliance is properly installed and grounded by a qualified technician in accordance with the installation instructions provided.

Before performing any service, DISCONNECT THE RANGE POWER SUPPLY AT THE HOUSEHOLD DISTRIBUTION PANEL BY REMOVING THE FUSE OR SWITCHING OFF THE CIRCUIT BREAKER.

Use only dry potholders. Moist or damp potholders on hot surfaces may result in burns from steam. Do not let potholders touch hot heating elements. Do not use a towel or other bulky cloth.

Keep oven and vent clean to maintain good venting and to avoid grease fires.

When cooking pork, follow the directions exactly and always cook the meat to an internal temperature of at least 170°F. This assures that, in the remote possibility that trichina may be present in the meat, it will be killed and the meat will be safe to eat.

Stand away from the oven when opening the oven door. Hot air or steam which escapes can cause burns to hands, face or eyes.

Do not attempt to repair or replace any part of your oven unless it is specifically recommended in this book. All other servicing should be referred to a qualified technician.



CAUTION: Items of interest to children should not be stored in cabinets above an oven. Children climbing on the oven to reach items could be seriously injured.

Do not store or use combustible materials, gasoline or other flammable vapors and liquids in the vicinity of this or any other appliance.

Do not let cooking grease or other flammable materials accumulate in or near the oven.

Do not touch heating elements or interior surface of oven. These surfaces may be hot enough to burn even though they are dark in color. Do not let clothing or other flammable materials contact the interior of the oven. Allow sufficient time for cooling.

Potentially hot surfaces include the oven vent opening and surfaces near the opening and crevices around the oven door. Remember: The inside surface of the oven may be hot when the door is opened.

Do not block oven vent area.

Keep oven free from grease buildup. Keep clean to maintain good venting and to avoid grease fires.

Place oven shelf in desired position while oven is cool. If shelves must be handled when hot, do not let potholder contact heating units in the oven.

Pulling out shelf to the shelf stop is a convenience in lifting heavy foods. It is also a precaution against burns from touching hot surfaces of the door or oven walls.

When using cooking or roasting bags in oven, follow the manufacturer's directions.

Do not use your oven to dry items; if overheated, they can catch fire.

Do not clean door gasket. The door gasket is essential for a good seal. Care should be taken not to rub, damage or move the gasket.

Do not use oven cleaners. No commercial oven cleaner or oven liner protective coating of any kind should be used in or around any part of the oven.

Clean only parts listed in this Owner's Manual.

Before self-cleaning the oven, remove broiler pan and other cookware.

Do not use aluminum foil anywhere in the oven except as described in this manual. Misuse could result in a shock, fire hazard or damage to the oven.

This appliance should be serviced only by qualified service personnel. Contact nearest authorized service facility for examination, repair or adjustment.

This appliance must be connected to a grounded, metallic, permanent wiring system, or an equipment grounding conductor should be run with the circuit conductors and connected to the equipment grounding terminal or lead on the appliance. The possibility of electrical shock exists with an unplugged microwave.

Do not operate this appliance if it is not working properly or if it has been damaged or dropped.

As with any appliance, close supervision is necessary when used by children.

If self-cleaning mode malfunctions, turn off and disconnect at the fuse or circuit breaker panel. Have serviced by a qualified technician.

Do not heat unopened food containers. Pressure build-up may make container burst and cause injury.

SAVE THESE INSTRUCTIONS IMPORTANT SAFETY NOTICE

The California Safety Drinking Water and Toxic Enforcement Act requires the governor of California to publish a list of substances known to the state to cause birth defects or other reproductive harm and requires businesses to warn customers of potential exposure to such substances.

The fiberglass insulation in self-clean ovens gives off a very small amount of carbon monoxide during the cleaning cycle. Exposure can be minimized by venting with an open window or using a ventilation fan or hood.

READ AND UNDERSTAND THIS INFORMATION NOW!

Should you ever need it, you will not have time for reading.

Never use water on a grease fire—it will only spread the flames.

OVEN FIRE

1. Close oven door and turn controls off.
2. IF FIRE CONTINUES, THROW BAKING SODA ON THE FIRE OR USE A DRY CHEMICAL FOAM, OR HALON TYPE EXTINGUISHER.

PRECAUTIONS TO AVOID POSSIBLE EXPOSURE TO EXCESSIVE MICROWAVE ENERGY

DO NOT ATTEMPT to operate this oven with the door open since open door operation can result in harmful exposure to microwave energy. It is important not to defeat or tamper with the safety interlocks.

DO NOT PLACE any object between the oven front face and the door or allow soil or cleaner residue to accumulate on sealing surfaces.

DO NOT OPERATE the oven if it is damaged. It is particularly important that the oven door close properly, and that there is no damage to the door, hinges and latches (broken or loosened), and door seals and sealing surfaces.

THE OVEN SHOULD NOT be adjusted or repaired by anyone except properly qualified service personnel.

TO REDUCE THE RISK OF FIRE IN THE MICROWAVE OVEN CAVITY:

Do not overcook food. Carefully attend appliance if paper, plastic, or other combustible materials are placed in the oven to facilitate cooking.

Remove wire twist-ties from paper or plastic bags before placing bags in oven.

Do not use your microwave oven to dry newspapers or other items.

Paper towels, napkins, wax paper and other recycle paper products can contain metal flecks which may cause arcing or ignite. Paper products containing nylon or nylon filaments should be avoided, as they may also ignite.

Do not pop popcorn in your microwave oven unless it is a special microwave popcorn accessory or unless you use popcorn labeled for use in microwave ovens.

Do not overcook potatoes. They could dehydrate, catch fire and damage your oven.

Do not operate the oven while empty to avoid damage to the oven and the danger of fire. If by accident the oven should run empty a minute or two, no harm is done. However, try to avoid operating the oven empty at all times—it saves energy and prolongs life of the oven.

If materials inside oven(s) should ignite, keep oven door closed, turn oven off, and disconnect the power cord, or shut off power at the fuse or circuit breaker panel.

Some products, such as eggs and sealed containers—for example, closed glass jars—may explode and should not be heated in this oven.

See door surface cleaning instructions in this manual.

Do not defrost beverages—especially carbonated ones—in narrow necked bottles. Even if the container is opened, pressure can build up. This can cause the container to burst, resulting in injury.

Use metal only as directed in cookbook. Foil strips used on meat roasts are helpful when used as shown in cookbook.

TV dinners may be microwaved in foil trays less than 3/4" high; remove top foil cover and return tray to box. When using metal in microwave oven, keep metal (except microwave oven shelf) at least 1" away from sides of oven.

Cooking utensils may become hot because of heat transferred from the heated food. Potholders may be needed to handle the utensil.

Sometimes the oven floor can become too hot to touch. Be careful touching the floor during and after cooking.

Foods cooked in liquids (such as pasta) may tend to boil over more rapidly than foods containing less moisture. Should this occur refer to the cleaning section of this manual.

Do not use a thermometer in food you are microwaving unless the thermometer is designed or recommended for use in the microwave oven.

Remove the temperature probe from the oven when not using it to cook with. If you leave the probe inside the oven without inserting it in food or liquid, and turn or

microwave energy, it can create electrical arcing in the oven and damage the oven walls.

AVOID heating baby food in glass jars, even without their lids; especially meat and egg mixtures.

Do not boil eggs in a microwave oven. Pressure can build up inside egg yolk and may cause it to burst, resulting in injury.

FOODS WITH UNBROKEN OUTER "SKIN" such as potatoes, sausages, tomatoes, apples, chicken livers and other giblets, and egg yolks (see previous caution) should be pierced to allow steam to escape during cooking.

PLASTIC UTENSILS designed for microwave cooking are very useful, but should be used carefully. Even microwave plastic may not be as tolerant of overcooking conditions as are glass or ceramic materials and may soften or char if subjected to short periods of overcooking. In longer exposures to overcooking, the food and utensils could ignite. For these reasons:

- 1) Use microwave plastics only and use them in strict compliance with the utensil manufacturer's recommendations.
- 2) Do not subject empty utensils to microwaving.
- 3) Do not permit children to use plastic utensils without complete supervision.

"BOILABLE" cooking pouches and tightly closed plastic bags should be slit, pierced or vented as directed in cookbook. If they are not, plastic could burst during or immediately after cooking, possibly resulting in injury.

Also, plastic storage containers should be at least partially uncovered because they form a tight seal. When cooking with containers tightly covered with plastic wrap, remove covering carefully and direct steam away from hands and face.

When heating packaged foods, always place them on a microwave proof dish. Examples are microwave French fries or microwave popcorn.

DO NOT deep fat fry in your microwave. This is not a safe procedure in the confined cavity.

DO NOT attempt to do home canning in your microwave. It is impossible to be sure all areas of the jar have reached boiling temperature for the proper processing time.

SPONTANEOUS BOILING — Under certain circumstances, liquids may start to boil during or shortly after removal from the microwave. To prevent burns from splashing liquid, stir liquid briefly before removing the container from the microwave oven.

This microwave oven is specifically designed to heat or cook food, and is not intended for laboratory or industrial use.

MICROWAVE OVEN SHELF ACCESSORY

Remove the shelf from the oven when not in use.

DO NOT store or cook with shelf on floor of oven. Product damage may result.

Use potholders when handling the shelf and utensils. They may be hot.

DO NOT use microwave browning dish on shelf. The shelf could overheat.

YOUR BUILT-IN OVEN

IMPORTANT:

The model and serial number of your oven is located inside the microwave on the left wall.

WINDOW WITH METAL SHIELD
Cooking can be viewed while keeping microwaves confined to oven.

DOOR LATCH

TEMPERATURE PROBE RECEPTACLE (See page 12)

GRILLE

MICROWAVE OVEN DOOR HANDLE. Pull to open. Door must be latched for oven to operate.

MICROWAVE OVEN CONTROLS
(See page 7)

MICROWAVE OVEN SHELF
(See page 19)

OVEN VENT AREA

LOWER OVEN CONTROLS
(See page 20)

OVEN VENT

GRILLE

SELF-CLEAN OVEN AUTOMATIC DOOR LATCH

LIGHT

BROIL ELEMENT

REMOVABLE OVEN RACK
(See page 28)

SELF-CLEAN OVEN INTERIOR
(See pages 25, 26)

REMOVABLE OVEN DOOR w/WINDOW
(Lower Oven; See page 28)

BAKE ELEMENT

OVEN DOOR GASKET
(See pages 25, 26)

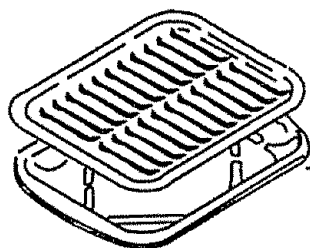

BROILER PAN & GRID
(See page 24)

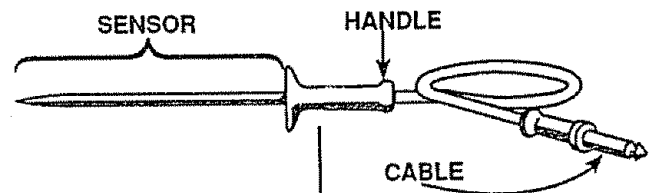

TEMPERATURE PROBE
(See page 12)

YOUR MICROWAVE TOUCH CONTROL

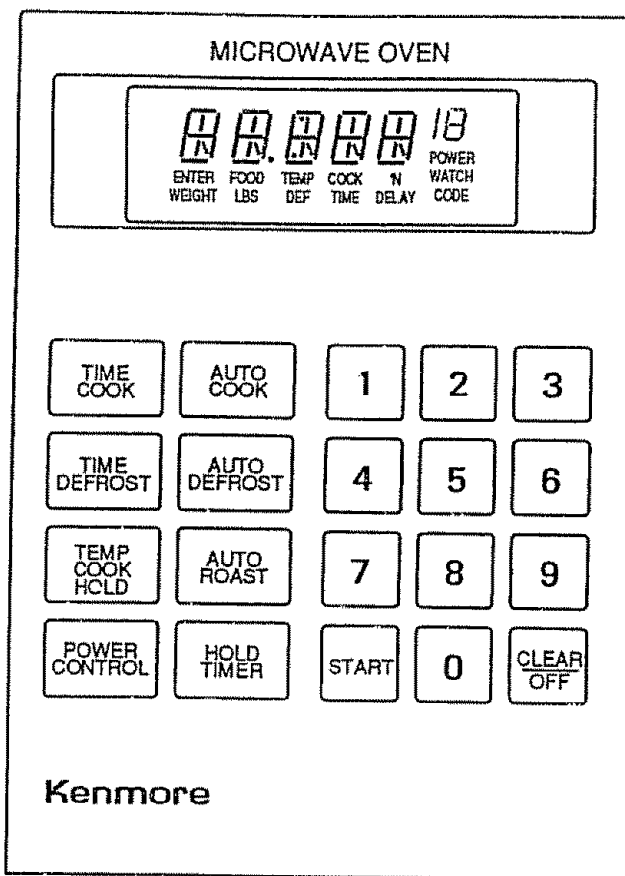

1. **DISPLAY** — Displays time or temperature during cooking functions, power level being used, cooking mode and instructions.

2. **TIME COOK** — Press to microwave using automatic Power Level 10. You may change power level after entering cooking time.

3. **TIME DEFROST** — Press for gentle thawing at automatic Power Level 3. You may change power level after entering defrosting time.

TEMP COOK/HOLD — Use the temperature probe to cook. Press this pad and then set a temperature by pressing number pads. Once food reaches this temperature, the oven switches to HOLD setting and maintains that temperature until you open the door or press the CLEAR/OFF pad.

4. **POWER CONTROL** — Press this pad before entering another power level number if you want to change from automatic Power Level 10 (HIGH) for cooking or Power Level 3 (LOW) for defrosting.

AUTO COOK — Press this pad and then number pad for desired code number, and oven automatically determines as pre-programmed power levels and

determines the proper amount of cooking time until the food is done and oven shuts off.

5. **AUTO DEFROST** — Press this pad, then Code number and food weight. The oven automatically sets power levels and defrosting time.

6. **AUTO ROAST** — Insert probe, touch this pad, and desired number pad for code to temperature cook meat with automatic program.

7. **NUMBER PADS** — Press these pads to enter cooking, defrosting time, temperature and power level.

8. **HOLD TIMER** — This feature uses no microwave energy when it functions as either a kitchen timer or as a holding period between defrost and time or temperature cooking.

9. **START** — After all selections are made, touch this pad to start oven.

10. **CLEAR/OFF** — When touched, it shuts off the oven and erases all settings.

NOTE: The microwave fan operates during microwave cooking and is also used to cool the control. Heat from the lower oven, along with heat from the microwave oven, may also cause the fan to operate. The fan may operate with both ovens off and will turn itself off

THE HOLD TIMER

The **HOLD TIMER** has three timing functions:

- It can be set as a minute timer.
 - It can be set as a holding time after defrosting.
 - It can be set to delay cooking.
- The **HOLD TIMER** operates without microwave energy.

TO SET MINUTE TIMER

The minute timer displays minutes:seconds. The maximum time setting is 99 minutes and 99 seconds.

1. Press **HOLD TIMER**.



2. Press number pads to set amount of time. For example, to set three minutes press 3, 0, and 0.



3. Press **START**.



When time is up, oven signals and display flashes "END".

To cancel press **CLEAR/OFF**.

USING A HOLDING TIME

The **HOLD TIMER** can be used to program a "holding time" between microwave cooking functions. The time can range from one second to 99 minutes and 99 seconds. A holding time may be found in some of your recipes.

PROGRAMMING DELAYED COOKING

1. To delay cooking up to 99 minutes and 99 seconds, touch either **TIME COOK**, **TEMP COOK/HOLD** or **AUTO ROAST**.
2. Enter cook time, temperature or code by pressing number pad(s).
3. Press **HOLD TIMER**.
4. Enter number of minutes to delay cooking. **WHEN DELAYING TEMP COOK/HOLD or AUTO ROAST, BE SURE PROBE IS IN FOOD.**
5. Press **START**. Timer will count down to zero. Cooking will begin when timer countdown is complete. Display will show power level when cooking begins.

To cancel, press **CLEAR/OFF**.

Note: Fan and light will operate but no microwave energy is used during delay.

If door is opened the countdown will stop. To resume delay program, close door and press **START**.

HOW TO TIME DEFROST, HOLD AND TIME COOK

1. Press **TIME DEFROST**.
2. Press number pads to set defrosting time. (Defrosting is automatically set on power level 3 but can be changed by touching the **POWER CONTROL** pad and the desired power level.)
3. Press **HOLD TIMER**.
4. Press number pads to set holding time.
5. Press **TIME COOK**.
6. Press number pads to set cooking time.
7. Press **START**.

(As each function is automatically performed, the oven display shows the instructions entered and the function.)

When time is up, the oven signals and the display flashes "END". The oven shuts off. To cancel, press **CLEAR/OFF**.

QUESTIONS AND ANSWERS

- Q. What will happen if I accidentally reverse my defrost, hold and cook instructions?
- A. The oven will automatically rearrange your program. Defrosting will always come first, then hold, and then the cooking function.
- Q. Can I defrost and hold only?
- A. Yes. All you need to do is program In Time Defrost and the amount of time, then program Hold and the amount of time. Be sure to put the thawed dish in the refrigerator promptly.
- Q. I programmed my oven for a specific defrosting time but it defrosted longer than necessary. What happened?
- A. When instructions conflict, the oven carries out the last instruction. You may have set oven to Defrost for 4 minutes, hold for 2 minutes, and then defrost for 6 minutes. The oven would defrost for 6 minutes and hold for 2 minutes.



Never let food such as dairy products, fish, meat, poultry, etc., sit for more than 1 hour before cooking starts, when you set your oven for a delay start. Room temperature promotes the growth of harmful bacteria.

MICROWAVE TIME COOKING

The time cooking feature allows you to preset the cooking time. The oven shuts off automatically at the end of the cooking time.

Power level 10 (High) is recommended for most cooking, but you may change this for more flexibility.

1. Press **TIME COOK**.



2. Press number pads to enter cooking time.

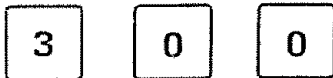

Power level 10 will be displayed. If power level 10 is not desired, press **POWER CONTROL** and then press number pad to select new power level.

3. Press **START**.



When time is up, the oven signals and display flashes "END". The oven light and fan shut off.

TIME COOK II

TIME COOK II lets you set two time cooking functions within one program. This is ideal when you want to change power levels during your cooking operations.

1. Press **TIME COOK**.



2. Press number pads to set cooking time.



Power level 10 will be displayed. If power level 10 is not desired, press **POWER CONTROL** and then press number pad to select new power level.

3. Press **TIME COOK**.



Power level 10 will be displayed. If desired, change power level as described above.

4. Press number pads to set second cooking time.



5. Press **START**.



The display will show "COOK TIME", the first power level, and the first programmed cook time, counting down.

At the end of the first programmed cook time, the second power level, "COOK TIME", and the second programmed cook time, counting down will show in the display.

When time is up, the oven signals and display flashes "END". The oven, light and fan shut off.

QUESTIONS AND ANSWERS

- Q. I set my oven for the time called for in the recipe, but at the end of the time allowed, my food wasn't done. What happened?
 - A. Many **TIME COOK** recipes give you a time range to prevent overcooking. Set the oven for the minimum time, test the food for doneness, and cook your food a little longer if necessary.
- Q. I touched the number pads and selected my power level. When I touched **START**, however, my oven did not come on. Why not?
 - A. **TIME COOK** must be touched before setting the cooking time with the number pads or else your oven will not begin cooking.
- Q. I want to cook on a power level other than High. What do I need to do?
 - A. To cook on a power level other than High, first touch **TIME COOK** and set the desired cooking time. Then touch **POWER CONTROL**. "Power 10" appears on the display. Enter new power level on the number pads and then touch **START**.
- Q. Can I interrupt my Time Cook function to check the food?
 - A. Yes. To resume cooking, simply close the door and press **START**. The time must be reset for cooking to resume unless time is remaining on timer.

DEFROSTING BY TIME

- Power Level 3 is automatically set for defrosting, but you may change this for more flexibility.
 - See your cookbook for defrosting help.
1. Press **TIME DEFROST**.
 2. Press number pads to set 1/2 of defrosting time in the cookbook.

Power level 3 will be displayed. If you wish to change the power level, press **POWER CONTROL** and the new number.

3. Press **START**.

When cycle is over, the oven signals and display flashes "**END**". The oven automatically shuts off.

4. Turn package over, stir food or rotate dish. Repeat steps 1-3.

DEFROSTING TIPS

- Foods frozen in paper or plastic can be defrosted in package.
- Family-size, pre-packaged, frozen entrees can be defrosted and microwaved. Remove from foil container and place in a microwave safe dish.
- For even defrosting some foods may need to be broken apart or separated part of the way through the defrosting time.
- Check your cookbook for defrosting tips.

QUESTIONS AND ANSWERS

- Q. When I press **START**, I hear a dull thumping noise. What is it?
- A. This sound is normal. It lets you know the oven is using a high power level.
- Q. Can I defrost small items in a hurry?
- A. Yes. Raise the power level after entering the time. Power level 7 cuts the total defrosting time about in half; power level 10 cuts the total defrosting time to about one-third. **During either, rotate or stir foods frequently.**
- Q. Why do the defrosting times in the cookbook not seem right for my food?
- A. Defrosting times are averages. Defrosting time can vary according to your freezer. Set your oven for the time indicated in the cookbook. If food is still not completely thawed at the end of that time, reset your oven and adjust time accordingly.

- Q. Should all foods be completely thawed before cooking?
- A. Some foods should not be completely thawed before cooking. For example, fish sticks should still be slightly frozen.
- Q. Can I open the door during defrosting to check on the progress of my food?
- A. Yes. You may open the door at any time during microwaving. To resume defrosting, close door and press **START**. If time is left on the timer, the oven begins operating. If not, reset timer.

AUTOMATIC DEFROSTING

With Auto Defrost, the oven automatically sets the defrosting time and power levels for you. First you choose the code number from 1 to 3 for the food you are defrosting, then enter the food weight in pounds and tenths of a pound (see Conversion Guide) and press **START**. The oven calculates defrosting time and changes power levels during defrosting to give even defrosting results.

TO SET AUTO DEFROST

1. Press **AUTO DEFROST**.
2. Press number pad to enter selected code from Auto Defrost Guide on next page.
3. Press number pads to enter weight. For example, press 1 and 2 for weight of 1.2 pounds. See Conversion Guide.
4. Press **START**. Display shows "DEF TIME" and defrost time counts down.

Twice during defrosting, the oven will beep four times, "**TURN**" flashes in display and oven shuts off. Open the door, attend your food (see Auto Defrost Guide), close door and press **START**. When defrosting is completed, "**END**" flashes and oven beeps four times. "**END**" remains on display and oven beeps every minute until door is opened or **CLEAR/OFF** is pressed.

STAND TIME

When using **Auto Defrost** feature, it is necessary to allow food to stand in order to finish defrosting. You may remove the food from the oven. In some cases, it should stand in your refrigerator. Recommended stand times are given in the Auto Defrost Guide.

CONVERSION GUIDE

If weight of food is stated in pounds and ounces, the ounces must be converted to tenths (.1) of a pound.

CONVERSION GUIDE

If weight of food is stated in pounds and ounces, the ounces must be converted to tenths (.1) of a pound.

| OUNCES | POUNDS | OUNCES | POUNDS | OUNCES | POUNDS | OUNCES | POUNDS |
|--------|--------|--------|--------|--------|--------|--------|--------|
| 1-2 | .1 | 4-5 | .3 | 8-10 | .6 | 12-13 | .8 |
| 3 | .2 | 6-7 | .4 | 11 | .7 | 14-15 | .9 |
| | | 8 | .5 | | | | |

AUTO DEFROST GUIDE

| CODE | RECOMMENDED FOODS | MIN.-MAX. WEIGHT | FIRST SIGNAL | SECOND SIGNAL | STAND TIME |
|--------------------------|--------------------------------|------------------|-------------------------------------|---|--------------------------------------|
| Meat 0-6.0 lbs | | | | | |
| | Chops | | Turn over. | Separate and shield where necessary. | 5 minutes |
| | Frankfurters, Sausage | | Separate. | Remove defrosted pieces | 2 minutes |
| | Ground Meat | | Turn over. | Remove defrosted areas and break apart. | 5 minutes |
| | Beef Patties | | Turn over. | Separate patties. | 5 minutes |
| | Roast | | Turn over and shield. | | 30 minutes in refrigerator |
| | Ribs | | Turn over. | Remove defrosted pieces. Shield if necessary. | 10 minutes |
| | Steak | | Turn over. | | 5 minutes |
| | Stew | | Turn over and separate. | Separate and remove defrosted pieces. | 5 minutes |
| Poultry 0-6.0 lbs | | | | | |
| | Whole Chicken | | Turn over and shield. | | 10 minutes; run cold water in cavity |
| | Turkey Breast (breast side up) | | Turn over. | Shield where necessary. | 20 minutes in refrigerator |
| | Chicken Pieces | | Turn over. | Separate and remove defrosted pieces. | 5 minutes |
| | Cornish Hens (whole) | | Remove wrapper and turn over. | | 10 minutes; run cold water in cavity |
| Seafood 0-3.0 lbs | | | | | |
| | Fish Fillets | | Turn over. | Separate and remove defrosted pieces. | 5 minutes |
| | Shrimp, Scallops | | Separate. | Separate and remove defrosted pieces. | 5 minutes |
| | Whole Fillets | | Turn over and shield tail and head. | | Hold under cold running water |

Edges or thin areas of meat will defrost more rapidly than other areas. After first or second signal, feel meat for warm spots and shield these areas with small pieces of foil. Do not let foil touch oven walls or oven door.

TEMPERATURE COOKING

Internal temperature is the best test of doneness for many foods.

Temp Cook/Hold takes the guesswork out of cooking because the oven automatically switches to "HOLD" setting after reaching the preset food temperature until you open the door or touch CLEAR/OFF.

TEMPERATURE PROBE

The temperature probe is a food thermometer that gauges the internal temperature of your food. The probe must be used when using TEMP COOK/HOLD or AUTO ROAST.

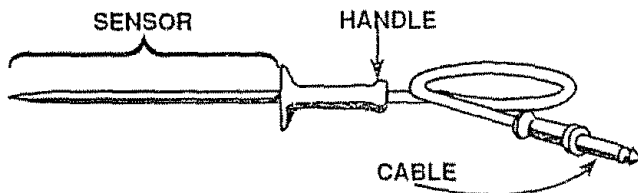

TO SET TEMP/COOK

1. Insert probe into food and seat cable end of probe securely into receptacle in oven wall. Close door.
2. Press TEMP COOK/HOLD. F (Fahrenheit) in display. ENTER TEMP will flash in display. See your cookbook for desired temperature.
3. Press number pads to enter desired temperature.
4. Press POWER CONTROL.
5. Press number pads to enter power level.
6. Press START. If internal temperature of the food is less than 80°F, the display will show "COOL". If temperature is 80°F or above, display will show temperature counting up.
7. When set temperature is reached, the oven will sound and display will show "HOLD". The oven will then hold the temperature.
8. Press CLEAR/OFF to stop the cycle.

If you fail to use the probe and try to set TEMP/COOK, display will flash "PROBE".

9. Remove probe and food from oven.

COOKING TIPS

- Use a lower power level; it will heat more evenly though requiring more time.
- Be sure frozen food is completely defrosted before inserting probe. Probe may break off if it is used in frozen foods.
- Cover foods loosely for moisture control and quick even heating.
- Delicate butter icings, ice cream, frozen toppings, etc., soften rapidly at warm temperatures. Batters, doughs, and frozen foods are also difficult to cook with the probe. It is best to TIME COOK these foods.

- "PROBE" will flash if you do not seat the cable end of the probe securely into the receptacle in the oven wall or if you touch AUTO ROAST and forget to use the probe.
- DO NOT leave the probe in the oven if it is not inserted in food or you may damage the oven.

You can set a minimum temperature of 80°F and maximum temperature of 199°F.

AUTO ROAST

AUTO ROAST uses the temperature probe to cook to the desired serving temperature. Auto Roast uses up to 3 power settings which automatically switch during roasting, providing tender, even cooking results without overcooking.

Just as in conventional roasting, only tender roasts should be Auto Roasted until specified internal temperatures are reached. Less tender roasts should be microwaved by time, according to your recipe.

PREPARE THE ROAST

Place tender beef roast on rack in microwave safe dish. Insert probe horizontally into the center meaty area, not touching bone or fat. Make sure the handle does not touch the food or sides of the oven. Cover with wax paper. Pork or ham roasts need no trivet. Add 1/2 cup water to roast dish; cover with plastic wrap. Allow room for probe when covering. Place meat in oven with probe to the right. Insert cable end of probe firmly into the receptacle on oven wall.

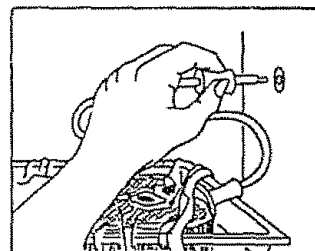
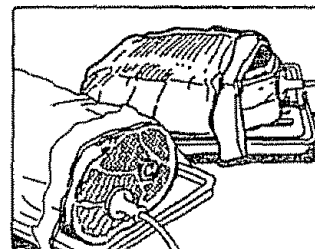
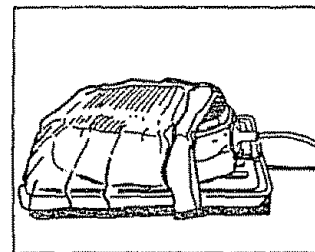

TO SET AUTO ROAST

1. Press AUTO ROAST. "AUTO" and "TEMP" appear on display and "ENTER CODE" flashes.
2. Press number pad to set Auto Roast Code. See Auto Roast Guide.
3. Press START. Display shows "COOL" and "CODE" until Food temperature reaches 80°F. At 80°F, display switches to show meat's internal temperature.
4. When you select Auto Roast Codes 1, 2, 3, or 4, the oven signals with 4 beeps and "TURN" flashes on the display when it's time to turn the roast over. After you turn the roast, close the door and press START again. (NOTE: Oven continues to cook after the signal whether or not roast is turned over.)

After a pre-programmed food temperature is reached, oven signals with 4 beeps and "END" appears on display.

AUTO ROAST GUIDE

- Use containers and coverings as directed. Place probe correctly in roast before cooking.
- Recommended codes are also shown inside oven on Auto Roast Guide.

| Food | Code | Final Temp | Approx Time (min. per lb.) | Hold* (min.) |
|-------------------------------|------|------------|----------------------------|--------------|
| Beef | | | | |
| Tender Roast | | | | |
| Rare | 1 | 115° | 10-13 | 0 |
| Medium | 2 | 125° | 13-15 | 0 |
| Well | 3 | 145° | 15-17 | 5-10 |
| Pork | | | | |
| Loin Roast | 4 | 170° | 14-17 | 10 |
| Precooked | 1 | 115° | 12-15 | 0 |
| Poultry | | | | |
| 3 lbs Whole Chicken | 5 | 190° | 10-12 | 10 |
| Whole Turkey** (up to 12 lbs) | 5 | 190° | 10-12 | 10-15 |
| Roast Breast** | 4 | 175° | 10-12 | 10-15 |

* If cooked to a final temperature of 140°F or above, still contain bacteria.

** Recommended standing time before serving.

*** Insert probe into meatiest area of inner thigh from below end and parallel to leg.

**** Insert probe horizontally into meatiest area.

AUTOMATIC SIMMERING (AUTO ROAST CODE 6)

Auto Roast code 6 is used for Automatic Simmering. Total time includes time to bring food to 180°F, and hold at that temperature until done. To set Auto Simmering, follow instructions for setting AUTO ROAST. Display shows "COOL" until food is 80°F, then switches to show food temperature until 180°F. Oven switches to Hold at

180°F until you remove food and turn off oven. If stirring is recommended, you can reset oven by retouching START. Press CLEAR/OFF after cooking.

AUTO SIMMERING GUIDE (AUTO ROAST CODE 6)

- Total time includes time to bring food to 180°F, and hold at that temperature until done.

| FOOD | APPROX. TIME/HOURS | COMMENTS |
|-----------------------------|--------------------|--|
| Beef Pot Roast | 5-7 | Add enough liquid to just cover meat. If adding vegetables, make sure they are completely covered by liquid. |
| Chili | 5-8 | Precook meat. Place probe 1" from top surface. Stir after 3 hours, if possible. |
| Chicken Stewing | 4-6 | Add 4 cups liquid. Insert probe into meatiest area of inner thigh from below end and parallel to leg. Turn over after 1/2 of time. |
| Broiler/Fryer | 3-4 | Same procedure as above. |
| Ham or Pork Roast | 4-6 | Add 4 cups liquid. |
| Soup Stock/ Vegetable | 7-10 | Make sure that vegetables and meat are covered by liquid. Stir every 3 hours. |
| Split pea | 5-7 | Add enough liquid to cover peas at least 2". |

AUTOMATIC COOKING

Use AUTO COOK to eliminate your need to look up cooking time in your cookbook or guess how long to set cooking time. By sensing the steam that escapes as food microwaves, the control adjusts the oven's cooking time to various types and amounts of food.

This feature is best used with foods that you want to steam or retain moisture.

NOTE: Use of the metal shelf with Automatic Cooking is not recommended.

TO SET AUTO COOK

1. Press AUTO COOK.
2. Press number pad of desired Code. See chart on next page.
3. Press START.

The word "AUTO" appears on the display and the sensor is activated to sense steam from food.

Refer to section on containers and covers on page 17.

KEEP DOOR CLOSED

Do not open the oven door while "AUTO" is displayed. Steam escaping from the oven can affect cooking performance. If the door is opened, "ERROR" appears. Close the door and press START immediately.

AUTOMATIC COOKING CODES

Automatic Cooking Codes 1 through 9 are designed to give you easy automatic results with a number of foods.

CODE 1 is designed for reheating foods quickly and turns off the oven automatically as soon as the sensor detects steam from the foods.

When CODES 2 through 9 are selected, the oven determines how much additional cooking time is needed after steam has been sensed. Oven automatically switches to TIME COOK and signals. When the signal is heard, the oven door may be opened for stirring, turning or rotating food.

A guide behind the oven door lists cooking codes for frequently prepared fresh or uncooked foods.

TO ADJUST AUTO COOK CODES

You can set the oven to cook for 20% less time than the code would regularly provide by adding a 1 after any Auto Cook code. You can set the oven to cook for 20% more time than the code would regularly provide by adding a 9 after any Auto Cook code.

1. Press AUTO COOK.
2. Press number pad of code and press 1 to adjust the code to cook 20% less time or 9 to adjust the code to cook 20% longer.
3. Press START. "AUTO" shows on display. DO NOT OPEN DOOR until first signal, then rotate dish 1/2 turn if needed. Close door and press START to finish cooking.

FOODS RECOMMENDED

A wide variety of foods including meats, fish casseroles, vegetables, leftovers and convenience foods can be Auto Cooked.

FOODS NOT RECOMMENDED

Foods that must be cooked uncovered, foods that require constant attention, foods that require addition of ingredients during cooking, and foods calling for a dry look and crisp surface after cooking should not be Auto Cooked. Time cook these foods. Foods that microwave best using the temperature probe should be Temp Cooked or Auto Roasted.

AUTOMATIC COOKING CONTROL GUIDE

- Do not open oven door during Auto cycle. When oven signals and countdown time is displayed, door may be opened for stirring, turning or rotating food. To resume cooking, close door and touch START.
- Match the amount of food to the size of container. Fill containers at least 1/2 full.
- Add 1/4-1/2 cup water to fresh vegetables.
- Most foods should be covered with lid to dish or wax paper to prevent spattering to keep oven clean. Spareribs, pot roasts and meat loaf should be covered tightly to ensure even cooking.
- Be sure outside of container and inside of oven are dry.
- If food needs additional cooking, return to oven and use Auto Cook Code 1.
- Use preference control "1" or "9" to adjust cook times to suit your individual tastes. See page 14.
- **Use of Automatic Cooking feature with DOUBLE DUTY® shelf is not recommended.**

NOTE: Oven will not accept "Auto Cook Code" if the oven is hot. If the words "Auto Cook Delay" appear, you must cool the oven before using Auto Cook or you may choose to use Time or Temperature Microwave Cooking.

| Food | "Auto Cook" Code | Container | Approx. Time | Comments |
|--|------------------|---|------------------------------|--|
| Canned Foods Thin foods such as soup, broth, gravy. | 1 | Microwave-safe container matched to size of food. | 2-3 min./cup | Cover with lid to dish or wax paper. |
| Thick foods such as canned ravioli, chunky soups, beef stew, all canned vegetables. | 1 | Microwave-safe container matched to size of food. | 4 min./cup | Cover with lid to dish or wax paper. |
| Leftovers | 1 | Microwave-safe container matched to size of food. | 4 min./cup | Cover with lid to dish or wax paper. |
| TV Dinners (except for those with pasta) | 2 | Cook in container (see comments). | 8-10 min. | If foil tray is no more than 3/4" deep, remove foil top, return to original box and reclose box. If tray is more than 1" deep, remove food and place in microwave-safe dish and cover. If dinner is in paper board container, remove from box and cook in original container. When microwaving meals containing 2 pouches, make 1-inch slit in center of each pouch. Place pouch containing meat on microwave-safe plate, with remaining pouch on top. Flex pouch before serving. |
| Frozen Entrees | 2 | Cook in container (see comments). | 17-20 min. depending on size | |
| Frozen Pouch Meats | 2 | | 3-8 min. | |
| Frozen Lasagna | 5 | 1 or 1 1/2 qt. casserole with lid to dish. | 10-20 min. | Remove lasagna from foil tray and place in microwave-safe dish and cover. Let stand 3 to 5 minutes before serving. |
| Casseroles With precooked ingredients in a white sauce such as tuna noodle casserole, turkey tetrazzini. | 4 | 2-3 qt. casserole with lid to dish. | 12-16 min. | Cover with lid. |
| With raw ingredients such as hamburger patty stew, scalloped potatoes, seafood casseroles. | 6 | 2-3 qt. casserole with lid to dish. | 16-24 min. | Cover with lid. |

AUTOMATIC COOKING CONTROL GUIDE

| Food | "Auto Cook" Code | Container | Approx. Time | Comments |
|--|------------------|----------------------------------|--------------------------------|---|
| Meats and Seafood | | | | |
| Chicken pieces (up to 3 lbs.) | 5 | 12 x 8 x 2-in. glass dish | 8-20 min. | Cover with wax paper to prevent spatters. |
| Fish fillets (1 lb.) | 1 | 12 x 8 x 2-in. glass dish | 6-9 min. | Cover tightly with plastic wrap. |
| Meat loaf (1 1/2 lbs.) | 9 | 10-in. pie plate | 25-30 min. | Cover tightly with plastic wrap. |
| Hamburger patties (4-5) | 3 | 12 x 8 x 2-in. glass dish | 7-9 min. | Cover with wax paper. When oven signals, rotate dish 1/2 turn. |
| Sausage patties (1 lb.) | 5 | 12 x 8 x 2-in. glass dish | 7-9 min. | Cover with wax paper. When oven signals, rotate dish 1/2 turn. |
| Pork chops (4-1" thick) | 6 | 12 x 8 x 2-in. glass dish | 22-25 min. | Baste with barbecue sauce. Cover with wax paper. When oven signals, rotate dish 1/2 turn. |
| Spare ribs (up to 3 lbs.) | 7 | 13 x 9 x 2-in. glass dish | 1 hr. 30 min. 1 hr. 45 min. | Cover tightly with plastic wrap, venting one corner. When oven signals, rearrange ribs. |
| Swiss steak (1 1/2 lbs.) | 7 | 3 qt. casserole w/lid | 60-65 min. | Cover with lid. |
| Chuck roast (up to 5 lbs.) | | 13 x 9 x 2-in. glass dish | 65-90 min. | Cover tightly with plastic wrap. |
| Shrimp (up to 1 lb.) | 4 | 1 1/2 qt. glass dish w/ lid | 4-6 min. | |
| Rice | | | | |
| Regular, raw, 1 cup | 9 | 2-qt. casserole w/lid | 21-28 min. | Follow instructions on rice package. |
| Instant, 1 cup | 1 | 2-qt. casserole w/lid | 5-8 min. | Follow instructions on rice package. |
| Vegetables | | | | |
| Fresh such as carrots, artichokes, cauliflower, broccoli, brussels sprouts (1 lb.) | 2 | 2-qt. casserole w/lid | 10-15 min. | Add 1/4 to 1/2 cup water. Cover with lid. |
| Baking potatoes, 2-4 | 9 | None | 8-16 min. depending on number | Pierce with fork and place on oven floor in a square arrangement. Turn potatoes over when oven signals and remaining time is displayed. |
| Frozen block such as peas, green beans, spinach, broccoli | 1 | 1 1/2 qt. casserole w/ lid | 8-10 min. | Add 2 tablespoons water. Cover with lid. |
| Lima beans | 1 | 1 1/2 qt. casserole w/lid | 12-13 min. | Add 1/4 cup water. Cover with lid. |
| Frozen pouch such as broccoli in butter sauce, corn, peas | 2 | Lay pouch on microwave-safe dish | 7-9 min. | Make 1" slit in pouch before cooking. Stir well before serving. |
| Fruit | | | | |
| Baked apples, 4 | 1 | 2-qt. casserole w/lid | 12-14 min. | Core apples and fill with butter and brown sugar. Cover with lid. |

If after completing Auto Cook Cycle, food needs additional warming, simply re-cover food and use Auto Cook Code #1.

MICROWAVING TIPS

- Make sure all cookware used in your microwave oven is suitable for microwaving. Most glass casseroles, cooking dishes, measuring dishes, measuring cups, custard cups, pottery or china dinnerware which does not have metallic trim or glaze with a metallic sheen can be used. Some cookware is labeled suitable for microwaving.

If you are not sure if a dish is microwave-safe, use this test: Place in the microwave oven both the dish you are testing and a glass measuring cup filled with one cup of water. Set the measuring cup of water either in or next to the dish. Microwave 1 minute at High power. If the dish heats, it should not be used for microwaving. If the dish remains cool and only the water in the cup heats, then the dish is microwave-safe.

- Paper towels, wax paper and plastic wrap can be used to cover dishes in order to retain moisture and prevent splattering. Be sure to vent plastic wrap so steam can escape.

- Some microwaved foods require stirring, rotating or rearranging. Check the cookbook.

- Steam builds up pressure in foods which are tightly covered by a skin or membrane. Pierce potatoes, egg yolks and chicken livers to prevent bursting.

COOKWARE FOR SHELF HEATING AND REHEATING

Before placing food in dishes to cook using your microwave oven shelf, check to see if the dishes will fit together on or under the shelf. Also, be sure cookware is microwave-safe.

Cookware for heating or reheating includes a 1-cup measuring cup, 9x5x3-inch loaf dishes or 9-inch pie plates.

Leftovers may be placed in small individual ceramic or plastic bowls or divided plates.

Use wax paper or plastic wrap instead of lids on casseroles. Lids may add too much height to dish.

AUTOMATIC COOKING CONTAINERS & COVERS CONTAINERS AND COVERS

Appropriate containers and coverings help assure good cooking results.

- Always use microwave-safe containers and cover them with lids, wax paper or plastic wrap. Wonder if it's microwave safe? Put it to the test described in Microwave Cooking Tips.

- Never use tight-sealing plastic covers—they can prevent steam from escaping and cause food to overcook.

- Match the amount of food to the size of the container. Fill containers at least half full.

- Be sure the outside of the cooking container and the inside of the microwave oven are dry before placing food in the oven. Beads of moisture turning into steam can mislead the sensor.

- Stir or rotate some foods after a beeping signal. See Automatic Cooking Control Guide.

Use microwave-safe casseroles or bowls for entrees and vegetables. Cover with lids that fit. If lids are not available, use plastic wrap or wax paper. Plastic wrap should be loose over food to allow for expansion. Seal by pressing plastic wrap firmly around edges.

For frozen entrees in paperboard trays, remove tray from box but do not remove film over tray. Thick entrees may take longer to cook—see guide on page 15.

For frozen foods in metal trays, remove foil covering and baked goods, re-insert tray into box and close ends of box.

Slit plastic pouches 1 inch as shown above. Break food up thoroughly after oven signals.

Use oblong or square containers for chicken or corn on the cob. Plastic wrap covering should be loose over food to allow for expansion. Seal by pressing plastic wrap firmly around edges.

Paper plates—while they may be used for Time and Temperature Cooking and Defrosting, do not use them with automatic cooking. Use microwave-safe plates or bowls for reheating. Cover with plastic wrap or wax paper.

Follow Automatic Cooking Control Guide setting for casseroles. Cover casserole meat and vegetables with sauce. Cool hot ingredients or sauces. If they are not cool, use TIME COOK.

QUESTIONS AND ANSWERS

- Q. Why does my oven cut off after the Auto cycle when using Auto Cook Code 1 when it does not alter other settings?
- A. When using Code 1, there is no second phase of minutes counting down. Cooking is completed in first phase of cooking.
- Q. If food is not completely cooked after using suggested code, what should I do?
- A. Use Time Cook and power level 10 for a few minutes to complete cooking.
- Q. Do all fresh or frozen vegetables require a standing period after cooking with Auto Cook?
- A. Most vegetables are cooked to a crisp state during Auto Cook. It is recommended that you let the vegetables stand for up to 5 minutes depending on size and density of pieces. The standing time also enhances the overall flavor and appearance of most vegetables.
- Q. What if I don't fully cover the dish in Auto Cook?
- A. Oven senses steam too quickly, shortens the cooking time and undercooks food. Cover tightly and reset Auto Cook.
- Q. Do the shapes and sizes of foods make a difference when using Auto Cook?
- A. Add water to the vegetables as recommended on guide and cover well for even, complete cooking.
- Q. Should I use Auto Cook to cook pudding or sauces?
- A. Most pudding and sauces require a lot of stirring during cooking; therefore, time cooking is recommended.
- Q. My scalloped potatoes were not completely cooked after using Auto Cook. Why not?
- A. If you prepared the sauce in the oven prior to covering the potatoes with the sauce, there may have been too much remaining moisture in the oven. Dry the oven completely before using Auto Cook since the function operates by sensing steam in the oven. Also, starting Auto Cook with hot foods causes steam in the oven too soon.
- Q. Which foods are best Time Cooked, rather than Auto Cooked?
- A. Bakery foods, candies, melted chocolate or foods when a dry or crisp surface is desired are cooked best by Time Cook.
- Q. Are plastic containers with tight fitting lids appropriate for Auto Cooking?
- A. No, most types of plastic storage dishes, butter tubs, etc., are not recommended for microwaving. Also tight fitting plastic lids may prevent adequate steam from escaping and may keep food from cooking properly.
- Q. I tried to warm chow mein noodles using Auto Cook. Why didn't this work?
- A. Food must have some moisture in order to create steam. Dry foods such as chow mein noodles, potato chips and other such foods do not have enough moisture.
- Q. May I use Auto Cook when I am cooking my foods in more than one dish?
- A. No. It is best to use Time Cook when cooking many foods.

YOUR MICROWAVE OVEN SHELF

IMPORTANT SAFETY INFORMATION

- **DO NOT STORE OR COOK with shelf on floor of oven. Product damage may result.**
- **Use potholders when handling metal shelf and utensils. THEY MAY BE HOT.**
- **DO NOT store microwave browning dish on metal shelf.**
- **Use of shelf with Automatic Cooking is not recommended.**

The wire shelf is designed for added capacity heating and reheating in your microwave oven. More than one food may be heated or reheated and ready to serve at the same time.

When microwaving with the oven shelf, it is important to arrange foods properly. Cookware size is important. Be sure dishes will fit together on or under the shelf. Food size should be considered; foods over 4 inches high or 3 1/2 lbs., are not recommended for shelf cooking.

Batters and dough foods and also uncooked foods which need to be prepared from scratch should be cooked without the oven shelf following recipe directions.

Use potholders when handling foods heated together with your oven shelf, especially when heating larger amounts of food. Extra steam generated from multiple food cooking may make cookware hotter than with regular microwaving.

POSITIONING THE SHELF

To position the microwave oven shelf, tip the back slightly and fit the shelf support guides onto the support guides located on each side of the oven in the rear.

Next, lower the front until the shelf support guides fit onto the support guides located at each side of the oven in the front.

When properly positioned, the shelf should fit snugly in place, be level and not touch the back wall of the oven.

If arcing occurs when using the shelf to cook more than one food at the same time, turn the oven off. Make sure the shelf is positioned right side up on all four shelf supports and not touching oven walls.

REHEATING IN YOUR MICROWAVE

Tips for Reheating Similar Foods

- Two plates of leftovers — Arrange thick or dense foods to outside edges of plate and cover with plastic wrap. Stagger plates with one on shelf and one on oven floor. Microwave for 2-3 minutes on HIGH (10) and reverse position of plates (top to bottom) and rotate 1/2 turn. Continue heating until hot.
- Two casseroles — Cover with plastic wrap. Use staggered arrangements of food. Place food on right side of shelf and left side of floor. Microwave and reverse positions of food after 1/2 of time. Also, heat small bowls of leftovers this way, stirring and reversing positions after half of time.
- Two frozen entrees (5-7 oz. each) or two TV dinners— Follow package directions. If there are foil covers, remove them. Place one TV dinner on right shelf and second dinner on left floor. Microwave and reverse positions (top and bottom) and rotate foods 1/2 turn. Continue microwaving as directed until foods are done.

Tips for Reheating Different Types of Food

When heating different types of food together, foods which should be served hot must be placed on the oven floor, while foods which are only warmed should be placed on the shelf. Microwave energy enters the oven from the bottom only. It is important to remember that foods absorb microwave energy at different rates. You may need to start heating large or dense food a few minutes ahead of smaller or less dense foods. Stagger and rotate foods as described above.

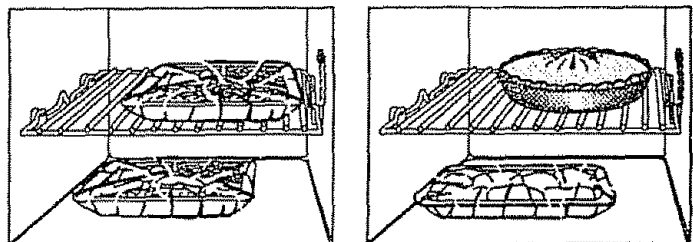
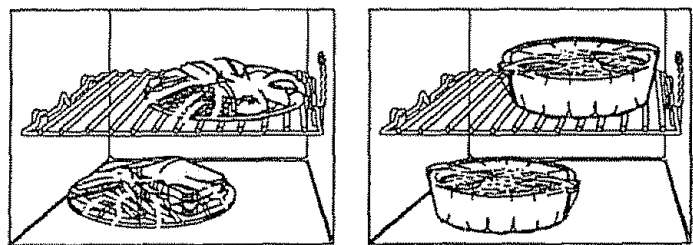

YOUR LOWER OVEN CONTROL

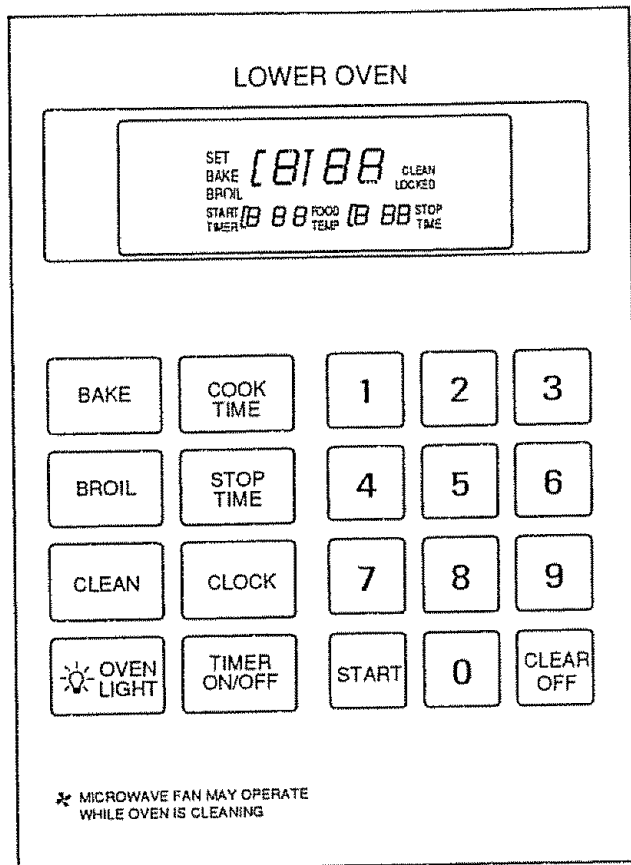

Clock must be set before any Conventional Oven Timer function will operate.

1. **DISPLAY** — Displays time of day, time or temperature during cooking, cooking mode, and tells you what to do next.
2. **BAKE** — Press to set oven to bake.
3. **BROIL** — Lets you broil at full power by touching BROIL and START pads. Lets you select Lo Broil for longer, slower broiling.
4. **CLEAN** — Press to select Self-Cleaning function. Follow all instructions in section on Self-clean cycle.
5. **OVEN LIGHT** — Press to turn oven light on and off.
6. **COOK TIME** — Use to enter amount of time required for automatic baking.
7. **STOP TIME** — Use when baking or cleaning to enter the time of day you want oven to turn off.
8. **CLOCK** — Press to enter time of day or check time of day when display is showing other information.
9. **TIMER** — Lets you time any kitchen function.
10. **START** — PRESS to start any cooking or cleaning function.
11. **CLEAR/OFF** — Cancels all operations except CLOCK and TIMER.
12. **NUMBER PADS** — Press these pads to set any function requiring numbers; time of day on clock, timer, oven temperature, internal food temperature,

starting and stopping times for timed oven operations.

THE CLOCK

To change the time of day all lower oven controls must be off.

When power is first connected to your cooking center or after a power failure, the digital display on both the microwave and the lower oven control will show lighted 8s and 18s and all oven functions for about 15 seconds.

Then all lights go off and "RESET" appears in the upper display and "PF" (Power Failure) appears in the lower display.

TO SET THE CLOCK

CLOCK MUST BE SET BEFORE ELECTRONIC CONTROLS FOR LOWER OVEN WILL WORK.

1. Press **CLOCK**.

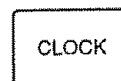

2. Press number pads to set time of day.

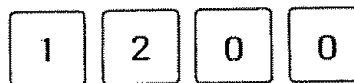

3. Press **START**.



TO RECALL TIME OF DAY

To check the time of day when display is showing other information, press CLOCK. The time of day shows as long as you press CLOCK, plus an additional 3 seconds.

TO ELIMINATE CLOCK DISPLAY

If you do not wish to use your Clock you can blank the time of day on your oven. Although you will not see it, the clock will maintain the correct time of day. It will reappear for the duration of any function that displays a start time and stop time.

1. Press and hold both **CLOCK** and **STOP TIME** until display goes blank.



To make the time of day reappear press **CLOCK**.

TIMER

The Timer can be set up to 11 hours and 59 minutes. The Timer counts down in minutes until the last minute is reached, then seconds are displayed. When the timer reaches "0", "TIMER" flashes in the display.

The smallest amount of time you can set is 1 minute.

NOTE: The Timer does not control oven operations. CLEAR/OFF does not control the Timer.

TO SET THE TIMER

1. Press TIMER.

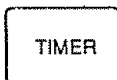

2. Press NUMBER pads to set the amount of time you want. For example, press 3,0,0, to set three hours.



If you make a mistake, press TIMER twice and begin again.

3. Press START.



The Timer will immediately start to countdown. After 1 minute has passed display will change. When time countdown is complete, the control will beep four times and the display will flash. Press TIMER to cancel.

TO CANCEL TIMER

4. Press TIMER.

THE RECALL MODE

Touch the pad of any function you have set to recall the information you set. The display will show the setting for 4 seconds.

If you recall a function and want to change it, press the appropriate pad and then enter new setting. Next, press START.

TO SET BAKE

1. Press BAKE. The display will show 0.

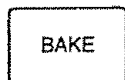

2. Press number pads to enter the temperature called for in your recipe. For example, press 3, 5, and 0, to set 350°F.
3. Press START. The display shows "BAKE", "TEMP", the oven set temperature and actual oven temperature as the oven heats. When set temperature is reached, the control beeps six times and "PrE" flashes in the display. The display then shows the set temperature continuously.
4. When baking is completed, press CLEAR/OFF.

NOTE: You can change the bake temperature while baking by pressing BAKE and the number pads for the new temperature.

TO SET IMMEDIATE START

Use this feature to start cooking now and have oven automatically enter HOLD MODE at end of cook time.

1. Press BAKE.
2. Press number pads to enter oven temperature.
3. Press COOK TIME.
4. Press number pads to enter length of cook time called for in your recipe. (Hours:minutes).
5. Press START.
6. When cook time is complete, the oven enters the HOLD MODE. Press CLEAR/OFF when you are ready to remove the food.

TO SET DELAY START

Use this feature to set your oven to turn on and automatically enter HOLD MODE at a later time.

Follow steps 1 through 4 under TO SET IMMEDIATE START, then:

5. Press STOP TIME.
6. Press number pads to enter time of day you want oven to turn off.
7. Press START. The control calculates the correct start time. Display shows time of day, "BAKE", "START TIME", AND "STOP TIME". The start time appears in the lower left display, and the stop time appears in the lower right display.

NOTE: If you entered an impossible Stop Time and Cook Time combination, such as one that would require a start time earlier than the current time of day, the "Err", "START TIME", and "STOP TIME" flash on display. To correct, press COOK TIME and enter the correct cook time or press STOP TIME and enter the correct stop time.

8. When Stop Time is reached, the oven automatically enters the HOLD MODE. Press CLEAR/OFF when you are ready to remove the food.

THE HOLD MODE

Your oven automatically enters the HOLD MODE after completing timed bake. At the end of timed baking, the word "End" flashes 4 times in the display and the control beeps 4 times. The oven temperature decreases to 150°F and the lower right display flashes "Hld". The oven temperature will remain 150°F until you press CLEAR/OFF.



When you set your oven for a delay start, never let food such as dairy products, fish, meat, etc., sit for more than 1 hour before cooking starts. Room temperature promotes the growth of harmful bacteria. Be sure the oven light is off because heat from the bulb will speed bacteria growth.



The low temperature zone of this range (between 150° and 200°F) is available to keep hot cooked foods warm. Food kept longer than two hours at these low temperatures may spoil.

OVEN COOKING

- When cooking a food for the first time in your new oven, use time given on recipes as a guide.

Your new oven has been set correctly at the factory and is more apt to be accurate than the oven it replaced.

After you have used your oven for awhile, if you feel your oven should be hotter or cooler, you can adjust it yourself. See **THERMOSTAT ADJUSTMENTS** in this manual.

- Always follow recipe carefully.
- Measure ingredients properly.
- Use proper pan placement.
- Place pans on the oven racks with 1" to 1 1/2" of air space on all sides of each pan. Avoid overcrowding the oven.
- Pans too close to each other, to oven walls or to the oven bottom block the free movement of air. Improper air movement causes uneven browning and cooking.

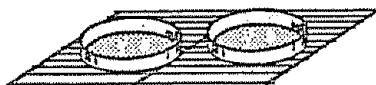

2 cake layers

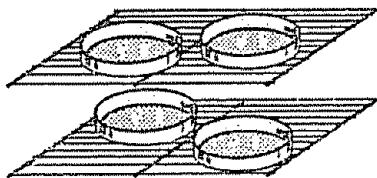

4 cake layers

- When baking several items stagger pans so that no pan is directly above another.
- Let the oven preheat thoroughly before cooking baked products. Listen for preheat notification tone and put the food in the oven.
- Opening the door too often to check food during baking will allow heat loss and may cause poor baking results.

- Cakes, cookies, muffins, and quick breads should be baked in shiny pans — to reflect the heat — because they should have a light golden crust. Yeast breads and pie crusts should be baked in glass or dull (non-shiny) pans — to absorb the heat — because they should have a brown, crisp crust.
- Be sure the underside of the pan is shiny, too. Darkened undersides will absorb the heat and may cause over-browning on the bottom of your food.

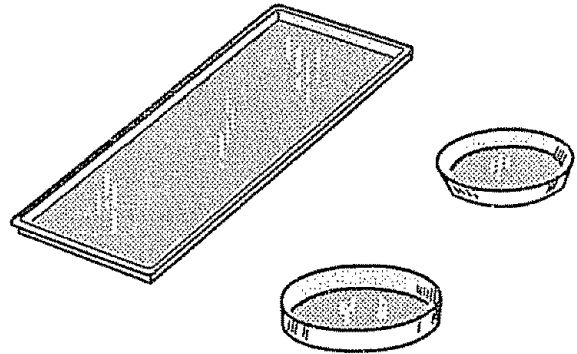

- Oven temperatures should be reduced 25 degrees below recommended temperatures if exterior of pan is predarkened, darkened by age or oven proof glass.
- There may be some odor when the oven is first used. This is caused by the heating of new parts and insulation.
- Do not cover an entire oven rack with foil. The foil can block normal heat flow and cause poor baking results. Do not place any foil directly above the bake element. Foil used on the oven bottom under the element may damage the oven surface; therefore, it should not be used.
- Cookies should be baked on flat cookie sheets without sides to allow the air to circulate properly. When recipes require preheating, have food nearby before you open the oven door. If the oven door is allowed to remain open for more than a brief time the preheat temperature will be lost.

Broiling

TO SET BROIL



1. Press BROIL. "HI" and "BROIL" appear in display.
2. Press BROIL again to set LO broil. You can alternate between HI(550°F) and LO(450°F) by pressing BROIL.
3. Press START.
4. Press CLEAR/OFF when broiling is complete.
Most foods can be broiled at the HI broil setting. Select the LO Broil setting to avoid excessive browning or drying of foods that should be cooked to the well-done stage (such as thick pork chops or poultry).

BROILING TIPS

- Your lower oven door should be open to the BROIL STOP position while broiling.
- Use only the broiler pan and grid that came with your range for broiling. They are designed for proper drainage of fat and liquids and help prevent spatter, smoke or fire.
- **Do not preheat when broiling.** Preheating may cause the thermostat to cycle the broil element off and on. For even broiling on both sides, start the food on a cold pan.
- Trim the outer layer of fat from steaks and chops. Slit the fatty edges to keep the meat from curling.
- For maximum juiciness, salt the first side just before turning the meat. Salt the second side just before serving.
- Brush chicken and fish with butter several times as they broil. When broiling fish, grease the grid to prevent sticking and broil with skin side down. It is not necessary to turn fish.
- **Never leave a soiled broiler pan in the range.** Grease in the pan may smoke or burn the next time the oven is used.
- **Be sure you know the correct procedure for putting out a grease fire. See the section on safety.**



Do not cover the entire broiler grid with foil. Poor drainage of hot fat may cause a broiler fire.

If a fire starts, close the oven door and turn controls off. If fire continues, throw baking soda on the fire. Do not put water on the fire.

POSITIONING BROILER PAN

Broiling is cooking by direct heat from the broil element. Tender cuts of meat or marinated meat should be selected for broiling. For best results steaks and chops should be at least 3/4" thick.

After placing food on the broiler pan, put the pan on an oven rack in the proper position. The recommended rack position and cooking time can be found in the chart below.

The closer the food is to the broil element, the faster the meat browns on the outside, yet stays red to pink in the center. Moving the meat farther away from the element lets the meat cook to the center while browning outside. Side one should be cooked 1-2 minutes longer than side two.

| Food | Rack Position 4 = Highest 1 = Lowest | Total Time (minutes) |
|------------------------|--|----------------------|
| Steak – 1" Thick | | |
| Rare | 4 | 9-11 |
| Medium | 3 | 13-15 |
| Well Done | 3 | 21-23 |
| Ground Beef Patties | | |
| Medium | 3 | 16-18 |
| Well Done | 4 | 7-9 |
| Lamb Chops – 1" Thick | 3 | 18-21 |
| Pork Chops – 1" Thick | 3 | 27-29 |
| Pork Chops 1/2" Thick | 3 | 16-18 |
| Ham Slice – 1/2" Thick | 3 | 11-12 |
| Fish (Filets) | 3 | 11-13 |
| Chicken (Halves) | 2 | 45-55 |
| Frankfurters | 3 | 8-11 |
| Bacon | 3 | 9-11 |

This chart is a general guide. The size, weight, thickness, and starting temperature of the food, as well as your own personal preference, will affect the cooking time. Times in the chart are based on the food being at refrigerator temperature.

THE SELF-CLEAN CYCLE

BEFORE A CLEAN CYCLE

1. Remove the broiler pan and grid, oven racks, all utensils and any foil that may be in the oven. Do not try to clean utensils or any other objects in the oven during a self-clean cycle. If oven racks are left in the range during a clean cycle, they will darken, lose their luster and become hard to slide. If you choose to leave the racks in the oven, you can polish the edges of the racks with steel wool and apply a small amount of vegetable oil to the rack edges after the self-clean cycle. This will make the racks easier to slide.
2. Soil on the oven front frame, the door liner outside the door seal, and the front edge of the oven cavity (approx. 1" into the oven) will not be cleaned during a clean cycle (see illustration below). Clean these areas by hand before starting a clean cycle.

Do not allow water to run down inside the slots in the door. Open the door completely when cleaning the top edge.

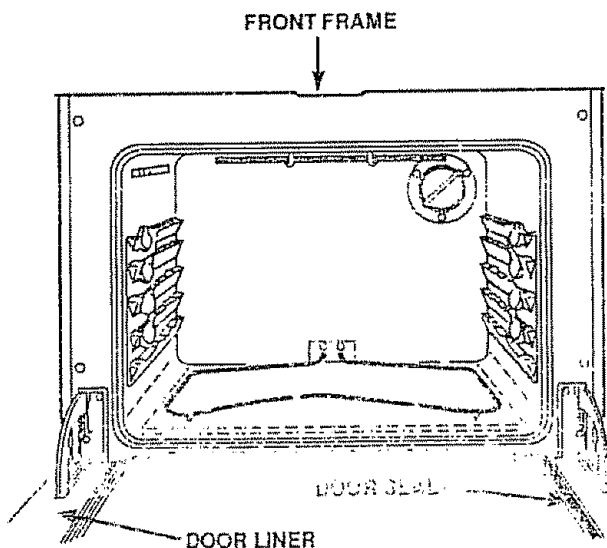

Use hot water with a soap-filled steel wool pad, then rinse well.

3. Wipe up heavy spillovers on the oven bottom. Too much soil may cause smoking during the clean cycle.
4. Do not rub the door seal. The fiberglass material of the seal has an extremely low resistance to abrasion. An intact and well fitting oven door seal is essential for energy efficient oven operation and good baking results. If you notice the seal becoming worn, frayed or damaged in any way or if it has become displaced on the door, you should replace the seal.

TO SET SELF-CLEAN CYCLE

1. Press CLEAN. The display will flash "START" and show the last entered clean time.
2. You can select a new clean time by pressing the number pads to enter hours: minutes desired for cleaning. The most frequently recommended clean time is three hours. You can set a clean time of 1:30 (one hour and thirty minutes) up to 4:00 (four hours).
3. To begin cleaning immediately, press START. The display will show the stop time, and "LOOK" will flash in the display for 15 seconds while the door locks. When the door is locked, "LOCKED" will remain in the display.

TO DELAY START OF CLEANING

Before setting delay start, make sure the oven clock shows the correct time of day.

Follow steps 1-2 above, then:

3. Press STOP TIME pad.
4. Press number pads for the time of day you want cleaning to be finished.
5. Touch START.

Display shows "START TIME", "STOP TIME", "CLEAN" and the time of day. When the door is locked, "LOCKED" will remain in the display.

NOTE: Oven automatically figures the starting time so cleaning will end at the stop time you have selected.

If you enter an impossible stop time, then "ERR", "START TIME", and "STOP TIME" flash in the display. To correct, press STOP TIME and enter a new stop time.

NOTE: Both the lower oven fan and the microwave fan may operate during or after self-cleaning and will continue to operate until control compartment temperatures cool down.

Your oven light should be OFF during a self-clean cycle to prolong the life of the bulb.

AFTER A CLEAN CYCLE

After a clean cycle is complete, the oven door will stay locked until the oven temperature cools to a safe level. When the oven has cooled "LOCKED" will disappear from display. "CLEAN" will remain in display until you press CLEAR/OFF or enter an oven operation. NEVER TRY TO FORCE THE DOOR TO OPEN WHEN "LOCKED" IS IN THE DISPLAY.

After a clean cycle, you may notice some white ash in the oven. Just wipe it up with a damp cloth.

If white spots remain, remove them with a soap-filled steel wool pad. Be sure to rinse thoroughly with a vinegar and water mixture. These deposits are usually a salt residue that cannot be removed by the clean cycle.

If the oven is not clean after one clean cycle, the cycle may be repeated.

TO INTERRUPT A CLEAN CYCLE

1. Press CLEAR/OFF.
2. Wait until "LOCKED" is no longer in display and door will open easily. Never force the door.

NOTE: The microwave cooling fan will come on approximately one hour into the clean cycle. The fan will run for a short period of time after the clean cycle is completed.

QUESTIONS AND ANSWERS

- Q. If my oven clock is not set to correct time of day, can I still self-clean my oven?
- A. Yes, however, if you desire to set a delay self-clean cycle to end at a specific time of day your clock should be set to the correct time of day.
- Q. Can I use commercial oven cleaners on any part of my self-cleaning oven?
- A. No cleaners or coatings should be used on or around any part of this oven.
- Q. Can I clean the woven gasket around the oven door?
- A. No. Do not to rub, move, or damage the gasket.
- Q. Is it normal to hear "crackling sound" during cleaning?
- A. Yes. This is the metal heating and cooling.
- Q. Why do I have ash left in my oven after cleaning?
- A. Some types of soil will leave a deposit. It can be removed with a damp sponge or cloth.
- Q. What should I do if excessive smoking occurs during cleaning?
- A. This is caused by excessive soil and you should switch the OVEN to OFF. Open windows to rid room of smoke. Allow the oven to cool for at least one hour before opening the door. Wipe up excess soil and reset the clean cycle.
- Q. Should there be any odor during the cleaning?
- A. Yes, there may be a slight odor during the first few cleanings. Failure to wipe out excessive soil might also cause an odor when cleaning.

CLEANING TIPS

On the following pages, all removable parts of your Cooking Center are shown. Refer to those pages when cleaning your Cooking Center. Warm water, a mild detergent, and a soft cloth are safe to use on all cleanable parts of your range. Do not use metal scouring pads, except where recommended. Range finish will be porcelain enamel. Porcelain enamel looks like a painted surface.

| PART | CLEANING MATERIALS | REMARKS |
|--|---|---|
| Bake and Broil Units | DO NOT clean the bake and broil units | Any soil will burn off when the unit is heated. NOTE: The bake unit is hinged and can be lifted gently to clean the oven floor. If spillover, residue or ash accumulates around the bake unit, gently wipe around the unit with warm water. |
| Broiler Pan and Grid | Detergent, warm water, soap-filled scouring pad, plastic scouring pad, commercial oven cleaner DO NOT use oven cleaner around any part of the oven | Remove soiled pan from oven to cool. Drain fat or drippings. Fill pan with warm water. Sprinkle grid with detergent and cover with damp cloth or paper towels. Let pan and grid soak for a few minutes. Rinse or scour as needed. Dry well. Grid and pan may be washed in a dishwasher. |
| Glass | Glass cleaner and paper towels If you need additional cleaning for spotting, wash with equal parts white vinegar and warm water. Rinse well and dry. Door should be completely open when cleaning top edge. | Do not allow water to run down inside openings in door while cleaning. Remove stubborn soil with paste of baking soda and water. Do not use abrasive cleaners. Rinse thoroughly. Door can be removed; see removable parts section. |
| Metal, Including Chrome Side Trims and Trim Strips | Soap and water | Wash, rinse, and then polish with a dry cloth. DO NOT use steel wool, abrasives, ammonia, acids, or commercial oven cleaners which may damage the finish. |
| Self-Cleaning Oven Interior | DO NOT use oven cleaner around any part of the oven Detergent, warm water, scouring pad or soap-filled steel wool pad | Rinse thoroughly after cleaning. Cleaning inside the oven need only be done as an optional touch-up between self-clean cycles. See the self-cleaning oven section of this manual for more information. |
| Oven Door Gasket of Self-Cleaning Oven | DO NOT CLEAN | DO NOT RUB, MOVE OR DAMAGE THE DOOR GASKET. See Self-Cleaning Section for more information. |
| Oven Racks | Detergent, warm water, scouring pad or soap-filled steel wool pad | Remove from oven to clean. Rinse thoroughly. |
| Control Panel | Lightly dampened cloth DO NOT use abrasive cleaners, steel or plastic pads. | Don't use sharp-edged utensils around the control panel. They might damage it. DO NOT use cleaning sprays or large amounts of soap and water. These can cause problems with the control mechanisms. |

CLEANING TIPS (Cont.)

| PART | CLEANING MATERIALS | REMARKS |
|--|---|--|
| Temperature Probe | Sudsy cloth, plastic scouring pad, water or dishwasher | Care should be taken in handling probe. DO NOT twist it. DO NOT drop it. Clean as soon as possible after use. Wipe with sudsy cloth, then rub metal parts with plastic scouring pad, if necessary. |
| Microwave Oven Shelf Accessory | Mild soap and water or dishwasher | Do not clean in self-cleaning oven. |
| Outside of Microwave Oven | Soap and damp cloth | Clean with soap and damp cloth, then rinse with damp cloth and dry. Wipe the window clean with a damp cloth. Chrome is best wiped with a damp cloth and then with a dry towel. |
| Inside Microwave Oven | Baking soda and water, Bon Ami® cleaner | <p>Open the door a few minutes after cooking to help air out the interior. Occasionally wipe with a solution of baking soda and water to keep interior fresh.</p> <p>Spills and splatters may wipe up with a paper towel. Some may require a damp cloth.</p> <p>Remove grease with a sudsy cloth, then rinse and dry. High heat generated by use of a Brown 'N Sear® dish may cause scorched appearing stains on oven floor. These may be removed with Bon Ami® brand cleanser. Follow instructions on can, then rinse and dry thoroughly. Do not use it on painted surfaces - it may scratch the paint.</p> |
| Microwave Oven Door: a) Window | Sudsy warm water | Wipe up splatters daily. Wash window with a small amount of sudsy, warm water. Rinse and dry. |
| b) Metal and plastic parts | Damp cloth Do not use abrasives, such as cleaning powders, or steel or plastic pads. | Use a damp cloth to remove all soil. |

REMOVABLE OVEN DOOR

To remove: Do Not lift by the door handle. Door glass breakage or damage to the door may result.

1. Open the door to the stop position (see illustration).
2. Grasp the door at each side and lift up and off the hinges.

NOTE: When the door is removed and hinge arms are at stop position, do not bump or try to move the hinge arms. The hinges could snap back causing an injury to the hands or damage to the porcelain on the front of the range. Cover the hinges with toweling or empty towel rolls while working in the oven area.

Do not allow water to run down inside the top slots in the door. Open the door completely when cleaning the top edge.

To replace:

1. Hold the door over the hinges with the slots at the bottom edge of the door lined up with the hinges. The hinge arms must still be in the stop position.
2. Slide the door down onto the hinges as far as it will go and close the door.

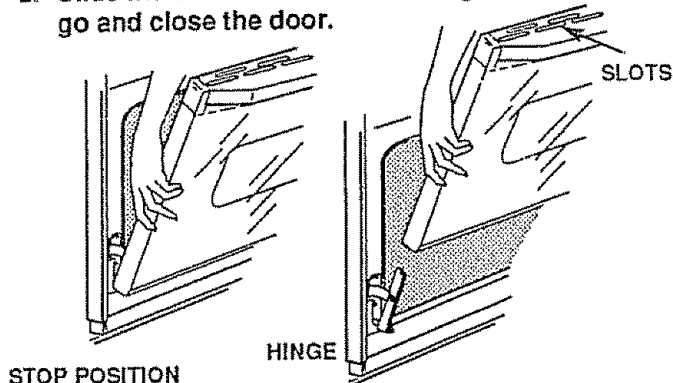

REMOVABLE OVEN RACKS

Be careful not to scratch the oven finish when installing or removing oven racks.

To install:

1. Set the raised back edge of the rack on a pair of rack guides.
2. Push the rack in until you reach the bump in the rack guide, then lift the front of the rack a bit and push the rack all the way in.

To remove:

1. Pull the oven rack out, then up, in one motion. See the cleaning chart.

NOTE:

For best performance, remove oven racks during a clean cycle. If oven racks are left in the range during a self-cleaning cycle, they will darken, lose their luster and become hard to slide. If you choose to leave the racks in the oven, you can polish the edges of the racks with steel wool and apply a small amount of vegetable oil to the rack edges after the self-clean cycle.

NOTE:

The racks are designed with stop locks. When the racks are placed correctly on the rack support and extended from the oven, the stop lock prevents the racks from tilting when you are removing food from the racks or placing food on them.

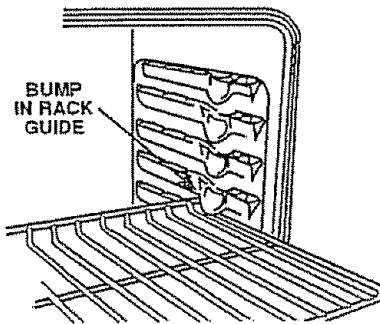

REPLACING OVEN LIGHT



Do not touch hot oven bulb. Do not touch bulb with wet hands. Never wipe oven light area with wet cloth.



Never touch the electrically live metal collar on the bulb when replacing.

To remove:

1. Disconnect electric power to the oven at the main fuse or circuit breaker or unplug the oven from the electric outlet.
2. Hold your hand under cover and firmly push back the ball wire until it clears the cover. The cover will fall into your hand. **DO NOT REMOVE ANY SCREWS TO REMOVE THE COVER.**
3. Replace bulb with 40-watt home appliance bulb.

To replace cover:

1. Place cover into groove of lamp receptacle. Pull wire bail forward until it snaps into place. Be certain wire bail is in center of cover. Wire will hold cover firmly when in correct position.
2. Connect power to oven.

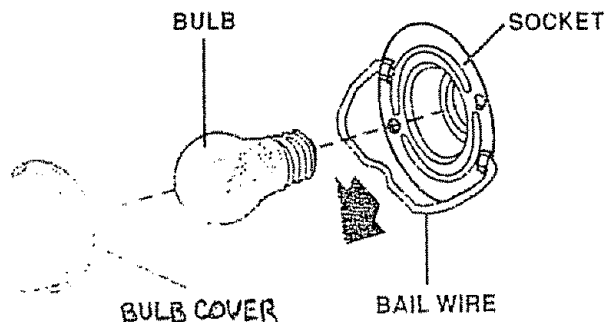

REMOVAL OF PACKAGING TAPE:

When packaging tape is removed from new appliances, a residue is sometimes left on the appliance. The safest way to remove this adhesive, and prevent damage to the product finish, is by using an application of household liquid dish washing detergent, mineral oil, or cooking oil. Apply with soft cloth and allow to soak. Wipe with soft cloth. **DO NOT** use plastic pad or equivalent. Wipe dry and then apply an appliance polish to thoroughly clean and protect the surface. This procedure is also safe for the face of microwave doors and other plastic and lexan parts.

NOTE: The plastic tape that is not removed from chrome trim on range parts **CANNOT** be removed if baked on.

MICROWAVE OVEN LAMP

To replace:

1. Disconnect power at main fuse or circuit breaker panel.

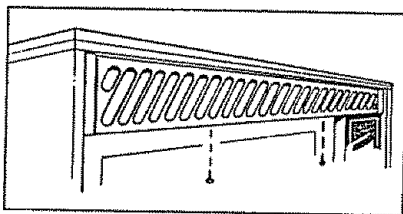

2. Open microwave oven door, then remove the two Phillips head screws from the bottom of the grille. Remove the grille.

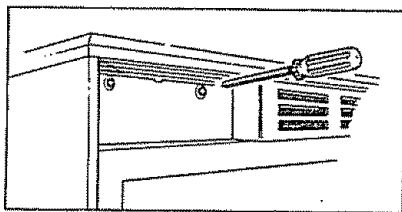

3. Remove the light cover by removing the two Phillips head screws.

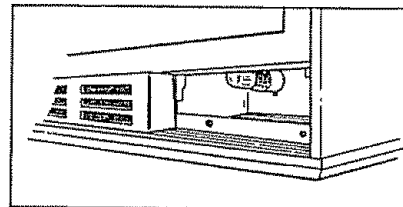

4. Remove the tape around the base of the light. The tape is there to prevent the light from loosening during shipment and door closings. Removing the tape may be difficult.

5. Unscrew the bulb carefully. Use a cloth to protect your hands in case the glass breaks.

NOTE: The light is not standard. Replace it with a similar 125 volt, 20 Watt bulb.

6. Screw replacement bulb into socket and replace light cover and grille. Reconnect power to cooking center.

MICROWAVE SHELF ACCESSORY

To position the Microwave Oven shelf, tip the back slightly and fit the shelf support guides onto the support guides located on each side of the oven in the rear.

Next, lower the front until the shelf support guides fit onto the support guides located at each side of the oven in the front.

When properly positioned, the shelf should fit snugly in place, be level and not touch the back wall of the oven.

NOTE: If electrical arcing occurs when using the shelf to cook more than one food at the same time, turn the oven off. Make sure the shelf is positioned right-side-up on all four shelf supports and not touching oven walls.

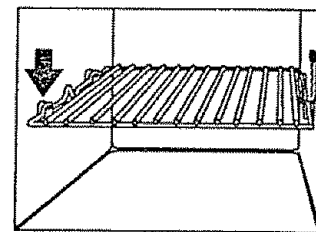
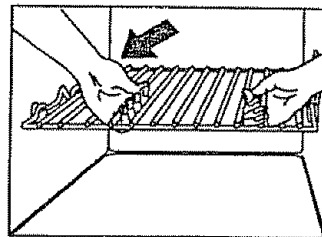

BEFORE CALLING FOR SERVICE

Save time and money — Check this list before you call for service.

To eliminate unnecessary service calls, first, read all the instructions in this manual carefully. Then, if you have a problem, always check this list of common problems and possible solutions before you call for service.

If you do have a problem you cannot fix yourself, call your nearest Sears Store or Service Center for help. When calling, have your manual and repair parts list handy with the model number, serial number and purchase date of your oven.

| PROBLEM | POSSIBLE CAUSE | DON'T CALL FOR SERVICE UNTIL YOU CHECK |
|---|--|---|
| <ul style="list-style-type: none"> Oven display flashes "F" and a number; oven stops working | <ul style="list-style-type: none"> Possible oven malfunction | <ul style="list-style-type: none"> Press CLEAR/OFF. Let oven cool down for 1 hour. Place oven back into operation. If problem repeats, call for service. |
| <ul style="list-style-type: none"> Oven does not work; totally inoperative | <ul style="list-style-type: none"> No power to oven | <ul style="list-style-type: none"> Check household circuit breaker or fuse. |
| <ul style="list-style-type: none"> Oven does not heat; clock okay | <ul style="list-style-type: none"> Oven controls set incorrectly Clock set incorrectly | <ul style="list-style-type: none"> Check oven control instructions. Clock must have correct time of day to set Timed Operations for specific time of day. |
| <ul style="list-style-type: none"> Foods do not bake properly | <ul style="list-style-type: none"> Oven not preheated long enough Improper rack or pan placement Improper use of foil Improper temperature setting for utensil used Recipe not followed Oven rack not level Using improper cookware | <ul style="list-style-type: none"> Be sure to preheat: until preheat tone sounds or 10 mins. Maintain uniform air space (1" to 1 1/2") around pans and utensils; see cooking hints section. Do not line oven bottom with foil. Do not cover an entire rack with foil. Reduce temperature 25 degrees for glass or dull/darkened pans. Is recipe tested and reliable? Check the Installation Instructions for leveling instructions. See oven cooking section. |
| <ul style="list-style-type: none"> Oven temperature seems inaccurate | <ul style="list-style-type: none"> Oven calibration Is recipe tested and reliable? | <ul style="list-style-type: none"> See Thermostat Adjustments. |
| <ul style="list-style-type: none"> Foods do not broil properly | <ul style="list-style-type: none"> Improper rack position Oven preheated Improper utensil used Oven door closed during broil Improper broiling time | <ul style="list-style-type: none"> Check broiler pan placement. See broiling section. Do not preheat when broiling. Use broiler pan and grid supplied with range. Open door to broil stop position; see removable oven door section. Check broiling chart in broiling section. |
| <ul style="list-style-type: none"> Oven smokes | <ul style="list-style-type: none"> Dirty oven Broiler pan containing grease left in oven | <ul style="list-style-type: none"> Wipe up heavy spillovers on the oven bottom. Clean pan and grid after each use. |
| <ul style="list-style-type: none"> Oven light does not work | <ul style="list-style-type: none"> Light switch in off position Light bulb burned out | <ul style="list-style-type: none"> Check switch setting. Check or replace light bulb; see removable parts section. |
| <ul style="list-style-type: none"> Tone does not sound | <ul style="list-style-type: none"> Tone has been eliminated | <ul style="list-style-type: none"> Push and hold CLEAR/OFF to activate tone. |

BEFORE CALLING FOR SERVICE (CONTINUED)

| PROBLEM | POSSIBLE CAUSE | DON'T CALL FOR SERVICE UNTIL YOU CHECK |
|--|---|--|
| <ul style="list-style-type: none"> • Food does not roast or bake properly | <ul style="list-style-type: none"> • Recipe not followed • Range and oven rack not level • Using improper cookware | <ul style="list-style-type: none"> • Is recipe tested and reliable? • Check the Installation Instructions for leveling instructions. • See cooking section of this manual. |
| <ul style="list-style-type: none"> • Lower oven will not self-clean or poor self-cleaning results | <ul style="list-style-type: none"> • Controls not set properly • Clean cycle interrupted too soon • Oven too dirty | <ul style="list-style-type: none"> • Check self-clean Instructions. • Heavily soiled ovens require a 3 1/2 hour clean cycle. • Heavy spillovers should be removed before setting clean cycle. Repeat clean cycle. |
| <ul style="list-style-type: none"> • Lower oven door will not unlock | <ul style="list-style-type: none"> • Clean cycle not complete | <ul style="list-style-type: none"> • Oven must cool below lock temperature after clean cycle is complete. |
| <ul style="list-style-type: none"> • Electronic Touch Pads will not work | <ul style="list-style-type: none"> • Clock not set | <ul style="list-style-type: none"> • Touch CLOCK pad and enter time. |
| <ul style="list-style-type: none"> • Electronic Display Panel goes blank or blinks | <ul style="list-style-type: none"> • Electrical service has caused interference on main power line | <ul style="list-style-type: none"> • If it can't be reset by touching pads, disconnect your cooking center at main fuse or circuit breaker. Wait one minute and reconnect power. Reset CLOCK. |
| <ul style="list-style-type: none"> • Control Panel on, yet oven will not operate | <ul style="list-style-type: none"> • START pad not touched • Door not closed correctly • Another function was touched • Numbers not entered after touching Time Cook • Finished temperature not entered after entering Auto Roast Code 7 • CLEAR/OFF pad touched accidentally • No code number entered after touching Auto Roast | <ul style="list-style-type: none"> • Touch START pad. • Make sure door is securely closed. • Touch CLEAR/OFF to cancel. • Complete setting. • Complete setting. • Repeat setting. • Complete setting. |

MICROWAVE OVEN

| PROBLEM | POSSIBLE CAUSE | DON'T CALL FOR SERVICE UNTIL YOU CHECK |
|--|---|---|
| <ul style="list-style-type: none"> • Foods overcooked or undercooked | <ul style="list-style-type: none"> • Not enough time set when using TIME COOK function because starting temperatures of foods varied widely • Probe not inserted properly • Incorrect power level entered • Dish not rotated, turned or stirred as called for in recipe • Too many dishes in oven at same time • Food not thoroughly defrosted • Improper use of coverings | <ul style="list-style-type: none"> • Varying density and amount of foods will sometimes require more cooking • Check Auto Roast section of manual • Is recipe recipe book • Follow recipe instructions • Do not overcrowd oven • Check Defrost section of manual • Follow instructions in manual and recipe. |
| <ul style="list-style-type: none"> • "PROBE" appears on display • "ERROR" appears on display | <ul style="list-style-type: none"> • Probe not used, although Auto Roast pad touched • Probe not inserted properly into oven receptacle or food • When using Auto Roast Code 7 to Temp Cook/Hold, you have entered a temperature of less than 80° or more than 199°F | <ul style="list-style-type: none"> • See PROBE section of manual. • See Auto Roast section of manual for instructions. |

ALL THESE ARE NORMAL ON YOUR MICROWAVE OVEN:

- Steam or vapor escaping from around door.
- Light reflection around door or outer case.
- Dull thumping sound while oven is in use.
- Microwave fan may operate with both ovens off. It is cooling the control and will turn itself off.
- Dimming oven light and change in blower sound may occur while operating at power levels other than high.
- Some TV-radio interference might be noticed while using your microwave oven. It is similar to the interference caused by other small appliances and does not indicate a problem with your oven.

THERMOSTAT ADJUSTMENTS

The temperature in your new oven has been set correctly at the factory, so be sure to follow the recipe temperatures and cooking times the first few times you bake in your oven.

If you think the oven should be hotter or cooler, you can adjust the oven temperature yourself. To decide how much to change the temperature, set the oven temperature 25°F higher or lower than the temperature in your recipe, then bake. The results of this "test" should give you an idea of how much the temperature should be changed.

To adjust temperature follow these instructions:

1. Push **BAKE**.

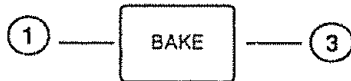

2. Select a temperature between 500°F and 550°F by pressing number pads.

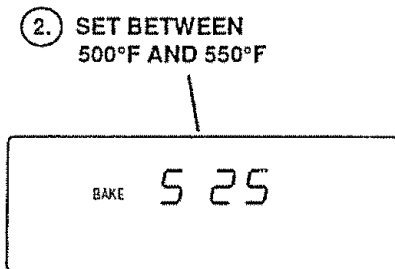

3. IMMEDIATELY, press **BAKE** again and hold for about 4 seconds. This display will show "ADJ" and "TEMP" will flash in the display.

Continue to hold **BAKE** until the display changes to show the preset oven temperature adjustment.

4. The temperature can be adjusted up to +35°F hotter or -35°F cooler. Press 1 to increase in 5° change. Press 0 to decrease in 5° change.

Press for +5° increase

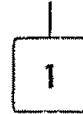

Press for -5° decrease

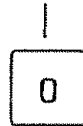

4. SET BETWEEN -35°F AND +35°F

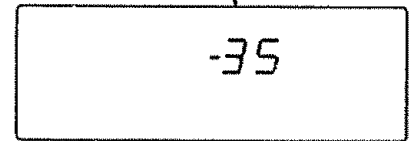

5. When you have made the adjustment, push **START** to return the display to the time of day. Use your oven as you would normally.

The adjustment you have made to the oven temperature will be remembered by the control and will automatically adjust the oven temperature by that amount each time you set a bake temperature.

NOTE: This adjustment will not affect Broil or Clean temperatures. It will be remembered when power is removed.

Pressing CLEAR/OFF or any function in the adjust thermostat mode will cancel the mode and any changes to the adjustment will not be saved.

NOTE:

We do not recommend the use of inexpensive thermometers, such as those found the grocery stores, to readjust the temperature of your oven. These thermometers may vary 20° - 40°F. Your oven has been preset to maximize cooking efficiency.

NOTES

KENMORE ELECTRIC OVEN WARRANTY

Dear Customer:

Our constant efforts are directed toward making sure your new Kenmore Oven will arrive at your home in perfect condition and will give you proper performance. As part of these efforts, we feel it is our responsibility to provide you with this warranty for your range.



FULL ONE YEAR WARRANTY ON THE FUNCTIONING OF ALL PARTS EXCEPT GLASS PARTS

If, within one year from the date of installation, any part, other than a glass part, fails to function properly due to a defect in material or workmanship, Sears will repair or replace it, free of charge.

FULL 30-DAY WARRANTY ON GLASS PARTS AND FINISH OF PORCELAIN ENAMEL, PAINTED OR BRIGHT METAL FINISHED PARTS

If, within 30 days from the date of installation, any glass part or the finish on any porcelain enamel, painted or bright metal part is defective in material or workmanship, Sears will replace the part, free of charge.

FULL 90-DAY WARRANTY ON MECHANICAL ADJUSTMENTS

For 90 days from the date of installation, Sears will provide, free of charge, any mechanical adjustments necessary for proper operation of the range, except for normal maintenance.

If the range is subjected to other than private family use, the above warranty coverage is effective for only 90 days.

WARRANTY SERVICE IS AVAILABLE BY CONTACTING THE NEAREST SEARS SERVICE CENTER/DEPARTMENT IN THE UNITED STATES

This warranty applies only while this product is in use in the United States. This warranty gives you specific legal rights, and you may also have other rights which vary from state to state.

SEARS, ROEBUCK and CO.
Dept. 731 CR-W
Sears Tower
Chicago, IL 60684

WE SERVICE WHAT WE SELL

"We Service What We Sell" is our assurance to you that you can depend on Sears for service because Sears service is nationwide.

Your Kenmore Oven has added value when you consider that Sears has a service unit near you staffed by Sears trained technicians. . . professional technicians specifically trained on Sears appliances, having the tools and equipment to ensure that we meet our pledge to you — "We Service What We Sell!"

TO FURTHER ADD TO THE VALUE OF YOUR RANGE, BUY A SEARS MAINTENANCE AGREEMENT.

Kenmore Ovens are designed, manufactured and tested for years of dependable operation. Yet, any modern appliance may require service from time to time. The Sears Warranty plus the Sears Maintenance Agreement provides protection from unexpected repair bills and assures you of enjoying maximum range efficiency.

Here's a comparative warranty and Maintenance Agreement chart showing you the benefits of a Sears Range Maintenance Agreement.

| Years of Ownership Coverage | | 1st Year | 2nd Year | 3rd Year |
|-----------------------------|--|--------------|----------|----------|
| 1 | Replacement of Defective Parts other than Porcelain or Glass | W | MA | MA |
| 2 | Mechanical Adjustment | 90 DAYS W | MA | MA |
| 3 | Porcelain and Glass Parts | 30 DAYS W | MA | MA |
| 4 | Annual Preventive Maintenance Check at your request | MA | MA | MA |

W - Warranty MA - Maintenance Agreement

CONTACT YOUR SEARS SALESPERSON OR LOCAL SEARS SERVICE CENTER TODAY AND PURCHASE A SEARS MAINTENANCE AGREEMENT.

Kenmore® America's Best Selling Appliance Brand

Sold by SEARS, ROEBUCK AND CO., Chicago, IL 60684

-- Printed in LaFayette, Georgia --