

# Owner's Manual

36" Gas-on-Glass Cooktop

Model ZGU36GG



**Monogram®**

Introduction

Your new Monogram cooktop makes an eloquent statement of style, convenience and kitchen planning flexibility. Whether you chose it for its purity of design, assiduous attention to detail—or for both of these reasons—you’ll find that your Monogram cooktop’s superior blend of form and function will delight you for years to come.

Your Monogram cooktop was designed to provide the flexibility to blend in with your kitchen cabinetry. Its sleek design can be beautifully integrated into the kitchen.

The information on the following pages will help you operate and maintain your cooktop properly.

Contents

<b>Care and Cleaning</b>	<b>Using Your Cooktop</b>
Burner Caps and Heads . . . . . 15	Cookware . . . . .13
Burner Grates . . . . . 16	Electric Ignition . . . . .12
Control Knobs . . . . . 14	Features . . . . . 11
Glass Cooktop Surface Cleaning . . . . . 17, 18	Flame Size . . . . . 12
Sealed Burner Assemblies . . . . . 14	LP Conversion Kit . . . . . 11
<b>Consumer Services</b>	Stove Top Grills . . . . .13
Before You Call for Service . . . . . 19	Wok Cooking . . . . .13
Important Phone Numbers . . . . . 20	
Model and Serial Number . . . . . 4	
Product Registration . . . . . 23, 24	
Safety Instructions . . . . . 2, 3, 5–10	
Warranty . . . . . 22	

**WARNING:** If the information in this manual is not followed exactly, a fire or explosion may result causing property damage, personal injury or death.

— Do not store or use gasoline or other flammable vapors and liquids in the vicinity of this or any other appliance.

**— WHAT TO DO IF YOU SMELL GAS**

- Do not try to light any appliance.
- Do not touch any electrical switch; do not use any phone in your building.
- Immediately call your gas supplier from a neighbor’s phone. Follow the gas supplier’s instructions.
- If you cannot reach your gas supplier, call the fire department.

— Installation and service must be performed by a qualified installer, service agency or the gas supplier.



---

**AVERTISSEMENT** : Si les informations de ce manuel ne sont pas suivies à la lettre, un incendie ou une explosion peut résulter et causer des dommages matériels, des blessures ou la mort.

— Ne stockez pas ou n'utilisez pas de l'essence ou d'autres vapeurs ou liquides inflammables à proximité de cet appareil électrique ou de tout autre.

— **QUE FAIRE SI VOUS SENTEZ DU GAZ**

- N'essayez pas d'allumer un appareil quelconque.
  - Ne touchez aux interrupteurs électriques ; n'utilisez pas les téléphones de votre immeuble.
  - Appelez immédiatement votre fournisseur de gaz à partir du téléphone d'un voisin. Suivez les instructions du fournisseur de gaz.
  - Si vous ne pouvez pas contacter votre fournisseur de gaz, appelez les pompiers.
- L'installation et l'entretien doivent être effectués par un installateur qualifié, une agence d'entretien ou le fournisseur du gaz.



## Consumer Information

---

### *Gas Cooktop*

---

#### *Before using your cooktop*

Read this manual carefully. It is intended to help you operate and maintain your new cooktop properly.

Keep it handy for answers to your questions.

If you don't understand something or need more help, there is a list of toll-free consumer service numbers included in the back section of this manual.

#### **OR**

Visit our Website at: [www.monogram.com](http://www.monogram.com)

---

#### *Write down the model & serial numbers*

You'll find them on a label under the cooktop.

Fill out and return the Consumer Product Registration Card that is packed with this product. If you cannot find it, please send in the duplicate card printed in the back of this manual.

**Before sending in the card, please write the numbers here:**

\_\_\_\_\_

Model Number

\_\_\_\_\_

Serial Number

Use these numbers in any correspondence or service calls concerning your cooktop.

---

#### *If you received a damaged cooktop*

Immediately contact the dealer (or builder) that sold you the cooktop.

---

#### *Save time & money*

Read this manual. Inside you will find many helpful hints on how to use and maintain your cooktop properly. Just a little preventive care on your part can save you a great deal of time and money over the life of your cooktop.

You'll find many answers to common problems in the Before You Call for Service section. If you review our chart of Troubleshooting Tips first, you may not need to call for service at all.

---

#### *If you need service*

To obtain service, see the Consumer Services page in the back of this manual.

We're proud of our service and want you to be pleased. If for some reason you are not happy with the service you receive, here are some steps to follow for further help.

FIRST, contact the people who serviced your appliance. Explain why you are not pleased. In most cases, this will solve the problem.

NEXT, if you are still not pleased, write all the details—including your phone number—to:

Manager, Customer Relations  
GE Appliances  
Appliance Park  
Louisville, KY 40225

# IMPORTANT SAFETY INSTRUCTIONS

---

## SAFETY PRECAUTIONS

### IMPORTANT SAFETY NOTICE:

- **The California Safe Drinking Water and Toxic Enforcement Act** requires the Governor of California to publish a list of substances known to the state to cause cancer, birth defects or other reproductive harm, and requires businesses to warn customers of potential exposure to such substances.

- **Gas appliances can cause minor exposure to four of these substances**, namely benzene, carbon monoxide, formaldehyde and soot, caused primarily by the incomplete combustion of natural gas or LP fuels.

Properly adjusted burners, indicated by a bluish rather than a yellow flame, will minimize incomplete combustion. Exposure to these substances can be minimized further by venting with an open window or using the ventilation fan.

- **When you get your cooktop, have the installer show you the location of the gas shut-off valve and how to shut it off if necessary.**
- **Have your cooktop installed and properly grounded by a qualified installer**, in accordance with the installation instructions. Any adjustment and service should be performed only by qualified gas range installers or service technicians.
- **Plug your cooktop into a 120-volt grounded outlet only.** Do not remove the round grounding prong from the plug. If in doubt about the grounding of the home electrical system, it is your personal responsibility and obligation to have an ungrounded outlet replaced with a properly-grounded three-prong outlet in accordance with the National Electrical Code. Do not use an extension cord with this appliance.
- **Be sure all packing materials are removed from the cooktop** before operating it to prevent fire or smoke damage should the packing material ignite.
- **Be sure your cooktop is correctly adjusted by a qualified service technician or installer for the type of gas (natural or LP) which is to be used.**
- **Do not attempt to repair or replace any part of your cooktop unless it is specifically recommended in this manual.** All other servicing should be referred to a qualified technician.

- **Do not leave children alone or unattended where a cooktop is hot or in operation.** They could be seriously burned.

- **CAUTION:** Items of interest to children should not be stored in cabinets above a cooktop—children climbing on the cooktop to reach items could be seriously injured.

**⚠WARNING:** NEVER use this appliance as a space heater to heat or warm the room. Doing so may result in carbon monoxide poisoning and overheating of the cooktop.

- **Clean the cooktop with caution.** If a wet sponge or cloth is used to wipe spills on a hot cooktop, be careful to avoid steam burns.
- **Do not clean the cooktop with flammable or volatile cleaning fluids.**
- **Do not clean the cooktop when the appliance is in use.**
- **Avoid scratching the cooktop** with sharp instruments, or with rings and other jewelry.
- **Let the burner grates and other surfaces cool before touching them or leaving them where children can reach them.**
- **Never use the cooktop as a cutting board.**
- **Never wear loose-fitting or hanging garments while using the appliance.** Be careful when reaching for items stored in cabinets over the cooktop. Flammable material could be ignited if brought in contact with flame or hot surfaces and may cause severe burns.
- **For your safety, never use your appliance for warming or heating the room.**
- **Do not use water on grease fires. Never pick up a flaming pan.** Turn the controls off. Smother a flaming pan on a surface burner by covering the pan completely with a well-fitting lid, cookie sheet or flat tray. Use a multi-purpose dry chemical or foam-type fire extinguisher.  
Flaming grease outside a pan can be put out by covering it with baking soda or, if available, by using a multi-purpose dry chemical or foam-type fire extinguisher.
- **Do not store flammable materials near the cooktop.** Do not store or use gasoline or other flammable vapors and liquids in the vicinity of this or any other appliance.

# IMPORTANT SAFETY INSTRUCTIONS

---

- **Do not let cooking grease or other flammable materials accumulate on or near the cooktop.**
- **Never leave surface burners unattended at high flame settings.** Boilovers cause smoking and greasy spillovers that may catch on fire.
- **Adjust surface burner flame size so it does not extend beyond the edge of the cookware.** Excessive flame is hazardous.
- **Use only dry pot holders**—moist or damp pot holders on hot surfaces may result in burns from steam. Do not let pot holders come near open flames when lifting cookware. Do not use a towel or other bulky cloth in place of a pot holder.
- **To minimize the possibility of burns,** ignition of flammable materials and spillage, turn cookware handles toward the side or center of the cooktop without extending over adjacent burner or vent area.
- **Always turn the surface burners to OFF before removing the cookware.**
- **Foods for frying should be as dry as possible.** Frost on frozen foods or moisture on fresh foods can cause hot fat to bubble up and over the sides of the pan.
- **Use least possible amount of fat for effective shallow or deep-fat frying.** Filling the pan too full of fat can cause spillovers when food is added.
- **Carefully watch foods being fried at high flame setting.**
- **If a combination of oils or fats will be used in frying,** stir together before heating, or as fats melt slowly.
- **Always heat fat slowly,** and watch as it heats.
- **Use a deep-fat thermometer whenever possible** to prevent overheating fat beyond the smoking point.
- **Use proper pan size**—avoid pans that are unstable or easily tipped. Select cookware having flat bottoms large enough to properly contain food and avoid boilovers and spillovers, and large enough to cover burner grate. This will both save cleaning time and prevent hazardous accumulations of food, since heavy spattering or spillovers left on cooktop can ignite. Use pans with handles that can be easily grasped and remain cool.
- **Keep all plastics away from burners.**
- **To avoid the possibility of a burn, always be certain that the controls for all burners are at the off position and all grates are cool before attempting to remove a grate.**
- **If the cooktop is located near a window,** do not use long curtains which could blow over the burners and create a fire hazard.
- **If you smell gas,** turn off the gas to the cooktop and call a qualified service technician. Never use an open flame to locate a leak.
- **Do not cover or block the area around the cooktop knobs.** This area must be kept clear for proper ventilation and burner performance.
- **Cook meat and poultry thoroughly**—meat to at least an INTERNAL temperature of 160°F and poultry to at least an INTERNAL temperature of 180°F. Cooking to these temperatures usually protects against foodborne illness.

- 
- Clean the cooktop with caution. If a wet sponge or cloth is used to wipe spills on a hot surface, be careful to avoid steam burns. Some cleansers can produce noxious fumes if applied to a hot surface.

**NOTE:** We recommend that you avoid wiping any surface unit areas until they have cooled and the indicator light has gone off. Sugar spills are the exception to this. Please see the Glass Cooktop Cleaning section.

- When the cooktop is cool, use only CERAMA BRYTE® Ceramic Cooktop Cleaner and the CERAMA BRYTE® Cleaning Pad to clean the cooktop.
- To avoid possible damage, do not apply the cleaning cream to the glass surface when it is hot.
- After cleaning, use a dry cloth or paper towel to remove all the cleaning cream residue.
- Read and follow all instructions and warnings on the cleaning cream labels.
- Do not operate the glass cooktop if the glass is broken. Spillovers or cleaning solution may penetrate a broken cooktop and create a risk of electrical shock. Contact a qualified technician immediately should your glass cooktop become broken.
- Do not stand on the glass cooktop.
- Do not touch glass surface while cooking. This surface may be hot enough to burn. During and after use, do not touch, or let clothing or other flammable materials contact the cooktop.  
Hot surfaces may include both the cooktop and areas facing the cooktop.
- Avoid scratching the glass cooktop. The cooktop can be scratched with items such as sharp instruments, rings or other jewelry and rivets on clothing.
- Large scratches or impacts to glass cooktops can lead to broken or shattered glass.
- Never use the glass cooktop surface as a cutting board.
- Be careful when placing spoons or other stirring utensils on glass cooktop surface when it is in use. They may become hot and could cause burns.
- To minimize the possibility of burns, always be certain that the controls for all surface units are at the OFF position and the entire glass surface is cool before attempting to clean the cooktop.
- Do not place or store items on top of the glass cooktop surface even when it is not in use.
- Use care when touching the cooktop. The glass surface of the cooktop will retain heat after the controls have been turned off.

**SAVE THESE INSTRUCTIONS**

# INSTRUCTIONS DE SÉCURITÉ IMPORTANTES

## PRÉCAUTIONS DE SÉCURITÉ

### AVIS IMPORTANT DE SÉCURITÉ :

- La loi de l'état de Californie sur l'eau potable sécurisée et l'application des lois sur les produits toxiques exige que le Gouverneur de Californie publie une liste de substances qui, selon les connaissances de l'état, causent le cancer, les maladies congénitales ou autre lésion reproductive, et exige que les entreprises avertissent leurs clients de leur exposition potentielle à de telles substances.

- Les appareils à gaz peuvent causer une exposition mineure à quatre de ces substances, soit le benzène, le monoxyde de carbone, le formaldéhyde et la suie, surtout à cause de la combustion incomplète du gaz naturel ou des carburants PL.

Des brûleurs correctement ajustés, ce qui est indiqué par des flammes bleuâtres plutôt que jaunes, réduiront au minimum la combustion incomplète. L'exposition à ces substances peut être réduite davantage en aérant avec une fenêtre ouverte ou en utilisant le ventilateur d'aération.

- Lorsque vous recevez votre cuisinière, demandez à l'installateur de vous montrer l'emplacement de la soupape d'arrêt et la façon de la fermer en cas de besoin.
- Demandez à un installateur qualifié d'installer et de mettre à la terre correctement votre cuisinière, conformément aux instructions d'installation. Tout ajustement ou entretien doit être effectué seulement par des installateurs de cuisinière à gaz qualifiés ou des techniciens de service.
- Branchez votre cuisinière seulement sur une prise de 120 volts mise à la terre. Ne retirez pas la broche ronde de mise à la terre de la prise. En cas de doute concernant la mise à la terre du système électrique de la résidence, vous assumez la responsabilité et l'obligation personnelles de faire remplacer toute prise non mise à la terre par une prise à trois broches correctement mise à la terre conformément au Code national de l'électricité. N'utilisez pas de rallonge de câble avec cet appareil.
- Assurez-vous que tous les matériaux d'emballage sont retirés de la cuisinière avant de la mettre en marche, pour empêcher les dommages d'incendie et de fumée au cas où le matériau d'emballage s'enflammerait.

- Assurez-vous que la cuisinière est ajustée correctement par un technicien de service ou un installateur qualifié en fonction du type de gaz (naturel ou PL) qui sera utilisé.

- N'essayez pas de réparer ou de remplacer toute pièce de la cuisinière sauf si cela est spécifiquement recommandé dans ce manuel. Toutes les autres actions de service doivent être référées à un technicien qualifié.

- Ne laissez pas les enfants seuls ou non surveillés lorsqu'une cuisinière est chaude ou en marche. Ils pourraient être brûlés grièvement.

- **ATTENTION :** Les articles suscitant l'intérêt des enfants ne doivent pas être rangés dans les armoires au-dessus de la cuisinière—les enfants grimpaient sur la cuisinière pour saisir ces articles pourraient être grièvement blessés.

### **⚠ AVERTISSEMENT :**

N'utilisez JAMAIS cet appareil pour réchauffer votre maison. Si vous le faites, vous risquez d'occasionner un empoisonnement par monoxyde de carbone et de surchauffer la cuisinière.

- Nettoyez la cuisinière avec précaution. Si une éponge ou un chiffon mouillé est utilisé pour essuyer les renversements sur une cuisinière chaude, faites attention d'éviter les brûlures causées par la vapeur.
- Ne nettoyez pas la cuisinière avec des nettoyants inflammables ou volatils.
- Ne nettoyez pas la cuisinière lorsqu'elle est en marche.
- Évitez de rayer la cuisinière avec des instruments pointus ou avec des bagues ou d'autres bijoux.
- Laissez refroidir les grilles des brûleurs et les autres surfaces avant de les toucher ou de les laisser là où les enfants peuvent les atteindre.
- N'utilisez jamais la cuisinière comme planche à découper.
- Ne portez jamais de vêtements lâches ou amples lorsque vous utilisez cet appareil. Faites attention pour saisir des articles rangés dans les armoires au-dessus de la cuisinière. La matière inflammable peut s'enflammer si elle entre en contact avec les flammes ou les surfaces chaudes et peut causer des brûlures graves.
- Pour votre sécurité, n'utilisez jamais votre appareil pour chauffer ou réchauffer la pièce.



- 
- **N'utilisez pas de l'eau sur les incendies de graisse. Ne saisissez jamais une poêle enflammée.** Arrêtez les contrôles. Éteignez les flammes d'une poêle placées sur un brûleur de surface en la recouvrant entièrement d'un couvercle bien ajusté, d'un plateau à gâteau ou d'un plateau plat. Utilisez un extincteur à produit chimique sec multi-usages ou du type à mousse.

Le graisse enflammée à l'extérieur d'une poêle peut être éteinte en la couvrant de bicarbonate de soude ou, s'il est disponible, en utilisant un extincteur à produit chimique sec multi-usages ou du type à mousse.

- **Ne stockez pas de matière inflammable près de la cuisinière.** Ne stockez pas et n'utilisez pas d'essence ou d'autres vapeurs ou liquides inflammables à proximité de cet appareil ou de tout autre.
- **Ne laissez pas la graisse de cuisson ou autre matière inflammable s'accumuler sur ou près de la cuisinière.**
- **Ne laissez jamais les brûleurs de surface sans surveillance lorsqu'ils sont réglés pour des flammes hautes.** Les débordements excessifs causent de la fumée et des renversements graisseux qui pourraient s'enflammer.
- **Ajustez la taille des flammes des brûleurs de surface pour qu'elles ne dépassent pas du bord du conteneur.** Les flammes excessives sont dangereuses.
- **Utilisez seulement des gants secs pour saisir les plats**—les gants humides ou mouillés placés sur des surfaces chaudes peuvent causer des brûlures dues à la vapeur. Ne mettez pas les gants près des flammes vives pour soulever les plats. N'utilisez pas de serviette ou autre chiffon encombrant au lieu des gants de plat.
- **Pour réduire au minimum la possibilité de brûlures, d'inflammation de matière inflammable et de renversement, tournez les poignées des plats vers le côté ou le centre de la cuisinière, sans les placer au-dessus d'un brûleur adjacent ou une zone d'aération.**
- **Arrêtez toujours les brûleurs de surface avant de retirer les plats.**
- **Les aliments à frire doivent être aussi secs que possible.** Le gel des aliments congelés ou l'humidité des aliments frais peut causer le bouillonnement des matières grasses chaudes et leur déversement sur le côté de la poêle.
- **Utiliser la quantité de graisse la plus faible possible pour la friture à la poêle ou à la friteuse.** Si l'ustensile est trop rempli de graisse, celle-ci peut déborder lorsque les aliments sont ajoutés.

- **Observez avec soin les aliments frits sur flammes hautes.**
- **Si un mélange d'huile et de matières grasses va être utilisé pour la friture, mélangez avant le chauffage ou à mesure que les matières grasses fondent lentement.**
- **Réchauffez toujours lentement les matières grasses et observez leur réchauffement.**
- **Utilisez un thermomètre de friteuse lorsque cela est possible** pour empêcher de surchauffer les matières grasses au-delà de leur point de fumée.
- **Utiliser des poêles de taille appropriée**— évitez les poêles qui sont instables ou qui peuvent basculer facilement. Sélectionnez des ustensiles de cuisine avec des fonds plats, suffisamment grands pour pouvoir correctement contenir les aliments et éviter les débordements et les déversements, et suffisamment grands pour recouvrir les grilles des brûleurs. Cela réduira le temps de nettoyage et empêchera les accumulations dangereuses d'aliments, étant donné que les éclaboussures ou les déversements importants laissés sur la cuisinière peuvent s'enflammer. Utilisez des poêles avec des poignées qui peuvent être facilement saisies et qui restent froides.
- **Eloignez tous les matériaux en plastique des brûleurs.**
- **Pour éviter les risques de brûlures, assurez-vous toujours que les contrôles des brûleurs sont à la position d'arrêt et toutes les grilles sont froides avant d'essayer de retirer une grille.**
- **Si la cuisinière est située près d'une fenêtre, n'utilisez pas de longs rideaux qui pourraient être projetés au-dessus des brûleurs et constituer un risque d'incendie.**
- **Si vous sentez du gaz, coupez l'arrivée du gaz à la cuisinière et appelez un technicien de service qualifié. N'utilisez jamais de flamme vive pour rechercher les fuites.**
- **Ne couvrez pas et ne bloquez pas la zone autour des boutons de la cuisinière.** Cette zone doit rester dégagée pour assurer une bonne ventilation et une bonne performance des brûleurs.
- **Cuisez la viande et la volaille complètement**— la viande à une température INTERNE d'au moins 160°F, et la volaille à une température INTERNE d'au moins 180°F. La cuisson à ces températures protège en général contre les maladies causées par les aliments contaminés.

# INSTRUCTIONS DE SÉCURITÉ IMPORTANTES

---

- Faites attention quand vous nettoyez la table de cuisson. Si vous utilisez une éponge ou un linge humide pour essuyer des éclaboussures sur la surface de cuisson chaude, faites attention d'éviter les brûlures dues à la vapeur. Certains nettoyants peuvent produire des émanations délétères s'ils sont mis sur des surfaces chaudes.

**NOTE :** Nous vous recommandons d'éviter d'essuyer la surface de cuisson tant qu'elle ne s'est pas refroidie et que la lumière indicatrice ne s'est pas éteinte. Les seules exceptions à cette règle sont les débordements de sucre. Veuillez consulter la section «Nettoyage de la table de cuisson en vitrocéramique».

- Lorsque la surface de cuisson a refroidi, n'utilisez que la crème nettoyante CERAMA BRYTE®, pour table de cuisson en vitrocéramique, et l'éponge CERAMA BRYTE® pour nettoyer la table de cuisson.
- Pour éviter tout dommage, n'utilisez jamais de crème nettoyante sur la surface de vitrocéramique quand elle est chaude.
- Après avoir nettoyé, utilisez un linge sec ou une serviette de papier pour enlever toute trace de crème nettoyante.
- Lisez et suivez toutes les instructions et les avertissements inscrits sur les étiquettes de la crème nettoyante.
- Ne faites jamais fonctionner la cuisson en vitrocéramique si la vitrocéramique est cassée. Des éclaboussures ou de la solution nettoyante peuvent pénétrer dans une table de cuisson cassée et peuvent occasionner un risque de secousse électrique. Appelez immédiatement un technicien qualifié si la vitrocéramique de votre table de cuisson se casse.
- Ne montez jamais sur la table de cuisson en vitrocéramique.
- Ne touchez jamais la surface en vitro quand vous cuisinez. Cette surface peut être assez chaude pour vous brûler. Pendant et après utilisation, ne touchez pas ou ne laissez aucun vêtement ou matériau inflammable entrer en contact avec la table de cuisson.  
  
Les surfaces chaudes peuvent être la table de cuisson elle-même, ainsi que la surface qui se trouve devant la table de cuisson.
- Évitez de rayer la vitrocéramique de la table de cuisson. Vous pouvez rayer la table de cuisson avec un petit article comme un instrument aiguisé, une bague, un bijou ou un accessoire de vêtement.
- De grandes rayures ou des chocs sur la table de cuisson peuvent provoquer une cassure de la vitrocéramique et occasionner des éclats.
- N'utilisez jamais la surface de la table de cuisson en vitrocéramique comme planche à découper.
- Faites attention quand vous placez des cuillères ou d'autres ustensiles de cuisine sur la surface de la table de cuisson en vitrocéramique quand vous l'utilisez. Ils peuvent se réchauffer et occasionner des brûlures.
- Pour réduire la possibilité de brûlure, assurez-vous toujours que les commandes pour toutes les unités de surface soient en position OFF (arrêt) et que toute la surface en vitrocéramique soit froide avant d'essayer de nettoyer la table de cuisson.
- Ne placez ou ne conservez jamais d'objet sur la surface de votre table de cuisson même quand vous ne l'utilisez pas.
- Faites attention quand vous touchez la table de cuisson. La surface de vitrocéramique de votre table de cuisson peut rester chaude après que vous l'avez réglée en position OFF (arrêt).

**CONSERVEZ CES INSTRUCTIONS**

# Features of Your Cooktop

Gas Cooktop

## Features

(Throughout this manual, features and appearance may vary.)

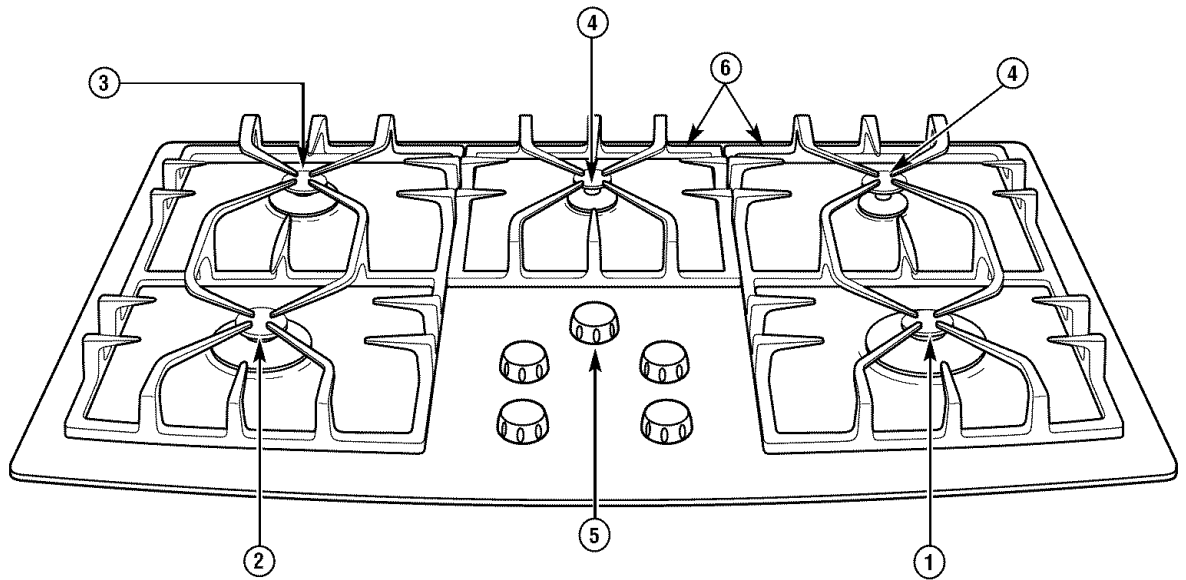

Feature Index (features and appearance may vary)		Page
1	Maximum Output Spillproof Burner	12, 14, 15, 16
2	High Output Spillproof Burner	12, 14, 15, 16
3	Medium Output Spillproof Burner	12, 14, 15, 16
4	Simmer Spillproof Burners	12, 14, 15, 16
5	Tactile-Touch Control Knobs (One for Each Surface Burner)	14
6	Interlocking Grates	16

## LP conversion kit

*Your cooktop is shipped from the factory set to operate only with Natural Gas.*

If you wish to use your cooktop with Liquefied Petroleum Gas, you must follow the Installation Instructions packed with your cooktop. See LP Gas Adjustments.

# Using Your Cooktop

---

## Gas Cooktop

---

### *Electric ignition*

Your surface burners are lit by electric ignition, eliminating the need for standing pilot lights with constantly burning flames.

All five igniters make clicking sounds and spark even when only a single burner is being turned on. Do not touch any of the burners when the igniters are clicking.

All of the burner igniters spark while a burner is relighting.

**In case of a power outage**, you can light the surface burners on your cooktop with a match. Hold a lighted match to the burner; then turn the knob to the HIGH position. **Use extreme caution when lighting burners this way.**

Surface burners in use when an electrical power failure occurs will continue to operate normally.

### *To light a burner*

Push the control knob down and turn it **counterclockwise** to the LITE position.

**After the burner ignites**, turn the knob in either direction to adjust the flame size from HI to LO.

**To turn a burner off**, turn the knob clockwise, as far as it will go, to the OFF position.

- All of the burners can be used for general cooking.

The front right burner is the maximum output burner best for larger pans and to bring liquids to a boil faster.

The smaller burners (center and right rear) will give the best simmer results. They offer precise cooking performance for delicate foods, such as sauces or foods which need to cook over low heat for a long time. They can be turned down to a very low simmer setting.

- Do not operate a burner for an extended period of time without cookware on the grate. The finish on the grate may chip without cookware to absorb the heat.
- Be sure the burners and grates are cool before you place your hand, a pot holder, cleaning cloths or other materials on them.
- Be sure you turn the control knob to OFF when you finish cooking.

### *How to select flame size*

Watch the flame, not the knob, as you reduce heat.

The flame size on a gas burner should be approximately the same **diameter** of the cookware you are using.

**FOR SAFE HANDLING OF COOKWARE, NEVER LET THE FLAME EXTEND UP THE SIDES OF THE COOKWARE.** Any flame larger than the bottom of the cookware is wasted and only serves to heat the handle.

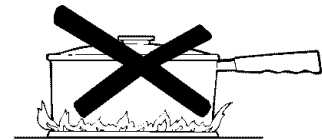

---

## Cookware

**Aluminum:** Medium-weight cookware is recommended because it heats quickly and evenly. Most foods brown evenly in an aluminum skillet. Use saucepans with tight-fitting lids for cooking with minimum amounts of water.

**Cast Iron:** If heated slowly, most skillets will give satisfactory results.

**Enamelware:** Under some conditions, the enamel of some cookware may melt. Follow cookware manufacturer's recommendations for cooking methods.

**Glass:** There are two types of glass cookware—those for oven use only and those for surface cooking (saucepans, coffee and teapots). Glass conducts heat very slowly.

**Heatproof Glass-Ceramic:** Can be used for either surface or oven cooking. It conducts heat very slowly and cools very slowly. Check cookware manufacturer's directions to be sure it can be used on gas cooktops.

**Stainless Steel:** This metal alone has poor heating properties, and is usually combined with copper, aluminum or other metals for improved heat distribution. Combination metal skillets generally work satisfactorily if they are used at medium heat as the manufacturer recommends.

---

## Wok this way

*We recommend that you use a flat-bottomed wok, available at your local retail store.*

Only a flat-bottomed wok should be used.

Do not use a flat-bottomed wok on a support ring. Placing the ring over the burner or grate may cause the burner to work improperly, resulting in carbon monoxide levels above allowable current standards. This could be dangerous to your health.



Use a flat-bottomed wok.

---

## Stove top grills

Do not use stove top grills on your sealed gas burners. If you use the stove top grill on the sealed gas burner it will cause incomplete combustion and can result in exposure to carbon monoxide levels above allowable current standards. This can be hazardous to your health.

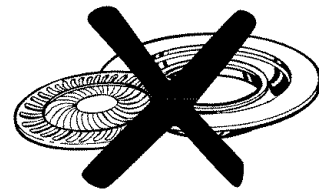

## Care and Cleaning

### Gas Cooktop

#### General information

Proper care and cleaning are important so your cooktop will give you efficient and satisfactory service. Follow these directions carefully in caring for it.

Some cooktop models are provided with cleaners. Follow the instructions on the containers.

Before cleaning any part of your cooktop, be sure all burners are off and cool. **DISCONNECT ELECTRICAL POWER TO THE COOKTOP** at the fuse box or circuit breaker panel, or pull the cooktop power plug, located beneath the cooktop and inside the cabinets.

#### Control knobs

The control knobs may be removed for cleaning.

**To remove knob**, pull it straight up.

The knobs have a tactile grip surface, but no special cleaning is required.

Wash the knobs in soap and water but do not soak. Avoid getting water down into the knob stem holes.

Replace the knobs after cleaning.

**NOTE:** The knob stem is **D-shaped**. Replace the flat side of the knob onto the flat side of the stem.

#### Sealed burner assemblies

Turn all controls OFF before removing the burner parts.

The burner grates, caps and burner heads can be lifted off, making them easy to clean.

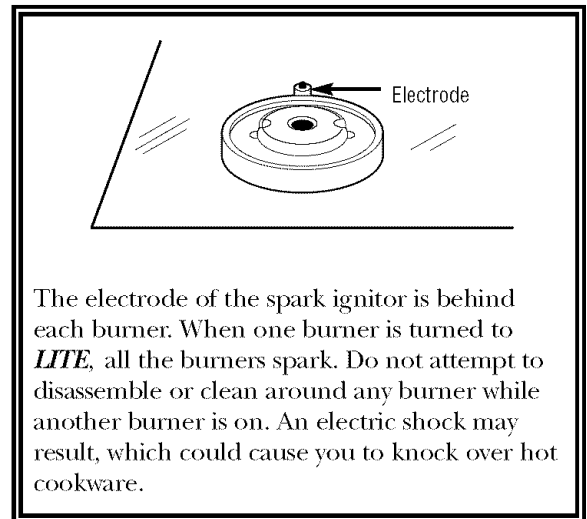
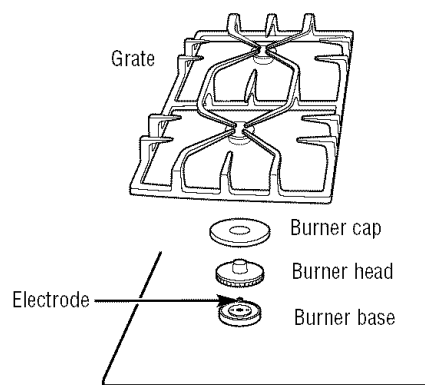

The electrode of the spark ignitor is behind each burner. When one burner is turned to **LITE**, all the burners spark. Do not attempt to disassemble or clean around any burner while another burner is on. An electric shock may result, which could cause you to knock over hot cookware.

**▲ CAUTION:** Do not operate the burner without all burner parts in place.

## Burner caps and heads

**NOTE:** Before removing the burner caps and heads, remember their size and location. Replace them in the same location after cleaning. The burner heads and burner bases are labeled B, C, D and H to aid reassembly.

### Burner caps

Lift off when cool. Wash burner caps in hot, soapy water and rinse with clean water. You may scour with a plastic scouring pad to remove burned-on food particles.

### Burner heads

The slits in the burner heads of your cooktop must be kept clean at all times for an even, unhampered flame.

You should clean the burner caps, burner heads and burner bases routinely, especially after bad spills, which could clog the openings in the burner heads. Lift off when cool.

To remove burned-on food, soak the burner heads in a solution of mild liquid detergent and hot water for 20–30 minutes. For more stubborn stains, use a toothbrush.

### After cleaning

Before putting the burner caps and heads back, shake out excess water and then dry them thoroughly by setting in a warm oven for 30 minutes.

## Replacement

The burner heads and burner bases are labeled B, C, D and H to aid reassembly.

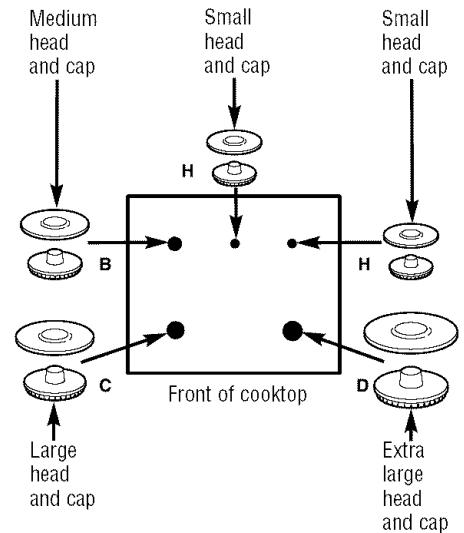

Replace the burner heads on the bases matching the letters. Replace the caps on the heads. Make sure that the caps and heads are replaced in the correct location. There are two small (H), one medium (B), one large (C) and one extra large (D) head and cap.

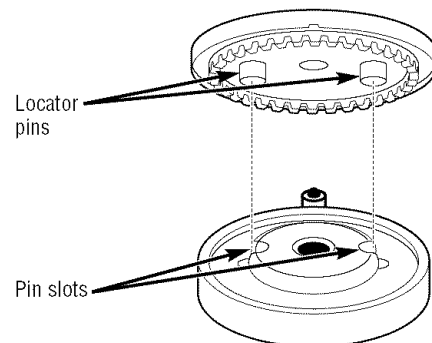

When replacing, make sure the locator pins in the burner head are seated in the pin slots of the burner base. Rotate the burner head around the burner base until it is level and securely seated.

### *Burner grates*

Cast-iron burner grates should be washed regularly and especially after spillovers.

Wash them in hot, soapy water and rinse with clean water. Dry the grates with a cloth—don't put them back on the cooktop wet.

The grates may also be cleaned in a dishwasher.

**Although they are durable, the grates will gradually lose their shine,** regardless of the best care you can give them. This is due to their continual exposure to high temperatures.

**Do not operate a burner for an extended period of time without cookware on the grate.**

The finish on the grate may chip without cookware to absorb the heat.

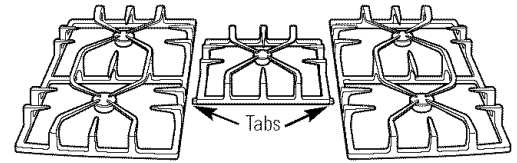

After cleaning, replace the center grate first with its locking side tabs toward the front.

Replace the side grates so that their side edges lock over the tabs on the center grate. Make sure the grates are positioned securely over the burners and that they are stable and level.

#### **Rubber Grate Feet**

For stability, your cooktop has rubber feet on the burner grates. If any of these rubber feet should become damaged or lost, replace them immediately.

To order replacement rubber grate feet, please call our toll-free number:

*National Parts Center* . . . . .800.626.2002

*Rubber Grate Feet* . . . . .#WB02T10101



# Glass Cooktop Surface Cleaning

Gas Cooktop

## Normal daily use cleaning

**ONLY** use CERAMA BRYTE® Ceramic Cooktop Cleaner on the glass cooktop. Other creams may not be as effective.

To maintain and protect the surface of your glass cooktop, follow these steps:

1. Before using the cooktop for the first time, remove the burner grates and clean the cooktop with CERAMA BRYTE® Ceramic Cooktop Cleaner. This helps protect the top and makes cleanup easier.
2. Daily use of CERAMA BRYTE® Ceramic Cooktop Cleaner will help keep the cooktop looking new.
3. Shake the cleaning cream well. Apply a few drops of CERAMA BRYTE® Ceramic Cooktop Cleaner directly to the cooktop.

4. Use a paper towel or CERAMA BRYTE® Cleaning Pad for Ceramic Cooktops to clean the entire cooktop surface.
5. Use a dry cloth or paper towel to remove all cleaning residue. No need to rinse.

**NOTE:** It is very important that you **DO NOT** heat the cooktop until it has been cleaned thoroughly.



**Clean your cooktop after each spill. Use CERAMA BRYTE® Ceramic Cooktop Cleaner.**

## Burned-on residue

**WARNING:** DAMAGE to your glass surface may occur if you use scrub pads other than the pad included with your cooktop.

**AVERTISSEMENT :** Vous pouvez ENDOMMAGER votre surface en vitrocéramique si vous utilisez des éponges de récurage autres que celles comprises avec votre appareil.

1. Allow the cooktop to cool.
2. Remove the burner grates. Spread a few drops of CERAMA BRYTE® Ceramic Cooktop Cleaner on the entire burned residue area.
3. Using the included CERAMA BRYTE® Cleaning Pad for Ceramic Cooktops, rub the residue area, applying pressure as needed.

4. If any residue remains, repeat the steps listed above as needed.
5. For additional protection, after all residue has been removed, polish the entire surface with CERAMA BRYTE® Ceramic Cooktop Cleaner and a paper towel.

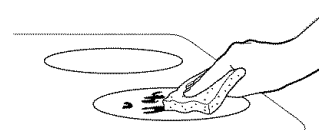

Use a CERAMA BRYTE® Cleaning Pad for Ceramic Cooktops or a Scotch-Brite® Multi-Purpose No Scratch blue scrub pad.

## Heavy, burned-on residue

1. Allow the cooktop to cool.
2. Remove the burner grates. Use a single-edge razor blade scraper at approximately a 45° angle against the glass surface and scrape the soil. It will be necessary to apply pressure to the razor scraper in order to remove the residue.
3. After scraping with the razor scraper, spread a few drops of CERAMA BRYTE® Ceramic Cooktop Cleaner on the entire burned residue area. Use the CERAMA BRYTE® Cleaning Pad to remove any remaining residue.

4. For additional protection, after all residue has been removed, polish the entire surface with CERAMA BRYTE® Ceramic Cooktop Cleaner and a paper towel.

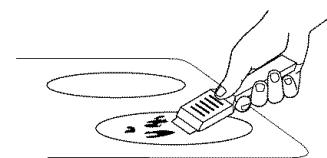

The CERAMA BRYTE® Ceramic Cooktop Scraper and all recommended supplies are available through our Parts Center. See instructions under "To Order Parts" section on next page.

**NOTE:** Do not use a dull or nicked blade.

# Glass Cooktop Surface Cleaning

---

## Gas Cooktop

### *Metal marks and scratches*

1. Be careful not to slide pots and pans across your cooktop. It will leave metal markings on the cooktop surface.

These marks are removable using the CERAMA BRYTE® Ceramic Cooktop Cleaner with the CERAMA BRYTE® Cleaning Pad for Ceramic Cooktops.

2. If pots with a thin overlay of aluminum or copper are allowed to boil dry, the overlay may leave black discoloration on the cooktop.

This should be removed immediately before heating again or the discoloration may be permanent.

**WARNING:** Carefully check the bottom of pans for roughness that would scratch the cooktop.

**AVERTISSEMENT:** Vérifiez soigneusement les fonds de vos casseroles pour vous assurer qu'ils n'aient aucune aspérité qui puisse endommager la surface de la table de cuisson.

---

## Glass Surface—Potential for Permanent Damage

---

### *Damage from sugary spills and melted plastic*

*Our testing shows that if you are cooking high sugar mixtures such as jelly or fudge and have a spillover, it can cause permanent damage to the glass surface unless the spillover is immediately removed.*

1. Turn off all surface burners. Remove hot pans and grates.
2. Wearing an oven mitt:
  - a. Use a single-edge razor blade scraper (CERAMA BRYTE® Ceramic Cooktop Scraper) to move the spill to a cool area on the cooktop.
  - b. Remove the spill with paper towels.

3. Any remaining spillover should be left until the surface of the cooktop has cooled.
4. Don't use the surface units again until all of the residue has been completely removed.

**NOTE:** If pitting or indentation in the glass surface has already occurred, the cooktop glass will have to be replaced. In this case, service will be necessary.

---

### *To Order Parts*

To order CERAMA BRYTE® Ceramic Cooktop Cleaner and the cooktop scraper, please call our toll-free number:

*National Parts Center*      800.626.2002.

**CERAMA BRYTE® Ceramic Cooktop Cleaner** .....# WX10X300

**CERAMA BRYTE® Ceramic Cooktop Scraper** .....# WX10X0302



**Kit** .....# WB64X5027  
(Kit includes cream and cooktop scraper)

**CERAMA BRYTE® Cleaning Pads for Ceramic Cooktops** . .# WX10X350

## Before You Call For Service

### Gas Cooktop

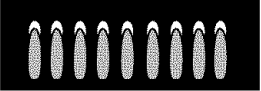
*Questions?  
Before you  
call for  
service...*

PROBLEM	POSSIBLE CAUSE
<p><b>BURNERS DO NOT LIGHT OR SPARK RANDOMLY</b></p>	<ul style="list-style-type: none"> <li>• Make sure electrical plug is plugged into a live power outlet.</li> <li>• Burner parts not replaced correctly.</li> <li>• Slits in the burner heads may be clogged.</li> </ul>
<p><b>BURNERS HAVE YELLOW OR YELLOW-TIPPED FLAMES</b></p>	<ul style="list-style-type: none"> <li>• Burner parts not replaced correctly. See the sealed burner assemblies section.</li> <li>• The combustion quality of burner flames needs to be determined visually.</li> </ul> <div style="display: flex; justify-content: space-around; align-items: flex-start;"> <div style="text-align: center;">  <p><b>A. Yellow flames:</b> <i>Call for service.</i></p> </div> <div style="text-align: center;">  <p><b>B. Yellow tips on outer cones:</b> <i>Normal for LP gas.</i></p> </div> <div style="text-align: center;">  <p><b>C. Soft blue flames:</b> <i>Normal for natural gas.</i></p> </div> </div> <ul style="list-style-type: none"> <li>• If burner flames look like (A), call for service. Normal burner flames should look like (B) or (C), depending on the type of gas. With LP gas, some yellow tipping on outer cones is normal.</li> </ul>
<p><b>BURNER FLAMES VERY LARGE OR YELLOW</b></p>	<ul style="list-style-type: none"> <li>• If cooktop is connected to LP gas, contact the person who installed your cooktop or made the conversion.</li> </ul>
<p><b>BURNER CONTROL KNOB WILL NOT TURN</b></p>	<ul style="list-style-type: none"> <li>• When the knob is at the OFF position, it must be pushed in before it can be turned, and it can only be turned in a <b>counterclockwise</b> direction. When the knob is at any other position, it can be turned in either direction without being pushed in.</li> </ul>
<p><b>SCRATCHES</b> <i>(may appear as cracks)</i> <b>ON COOKTOP GLASS SURFACE</b></p>	<ul style="list-style-type: none"> <li>• Incorrect cleaning methods have been used. Scratches are not removable. Tiny scratches will become less visible in time as a result of cleaning.</li> <li>• Cookware with rough bottoms being used or coarse particles (salt or sand) were between the cookware and the cooktop surface. Cookware has been slid across the cooktop surface. To avoid scratches, use the recommended cleaning procedures. Make sure bottoms of cookware are clean before use, and use cookware with smooth bottoms.</li> </ul>
<p><b>AREAS OF DISCOLORATION ON THE COOKTOP SURFACE</b></p>	<ul style="list-style-type: none"> <li>• Food spillovers not cleaned before the next use. See the <i>Glass Cooktop Surface Cleaning</i> section.</li> </ul>
<p><b>PLASTIC MELTED TO THE SURFACE</b></p>	<ul style="list-style-type: none"> <li>• Hot cooktop came into contact with plastic placed on the hot cooktop. See the <i>Glass surface – Potential for permanent damage</i> section in the <i>Glass Cooktop Surface Cleaning</i> section.</li> </ul>
<p><b>PITTING (OR INDENTATION) OF THE COOKTOP SURFACE</b></p>	<ul style="list-style-type: none"> <li>• A hot sugar mixture was spilled on the cooktop. Call a qualified technician for replacement.</li> </ul>

---

*With the purchase of your new Monogram appliance, receive the assurance that if you ever need information or assistance from GE, we'll be there. All you have to do is call—toll-free!*

---

**GE Answer Center®**

**800.626.2000**

Whatever your question about any Monogram major appliance, GE Answer Center® information service is available to help. Your call—and your question—will be answered promptly and courteously. And you can call any time. GE Answer Center® service is open 24 hours a day, 7 days a week.

**OR**

Visit our Website at: [monogram.com](http://monogram.com)

---

**In-Home Repair Service**

**800.444.1845**

A GE consumer service professional will provide expert repair service, scheduled at a time that's convenient for you. Many GE Consumer Service company-operated locations offer you service today or tomorrow, or at your convenience (7:00 a.m. to 7:00 p.m. weekdays, 9:00 a.m. to 2:00 p.m. Saturdays). Our factory-trained technicians know your appliance inside and out—so most repairs can be handled in just one visit.

---

**For Customers With Special Needs...**

**800.626.2000**

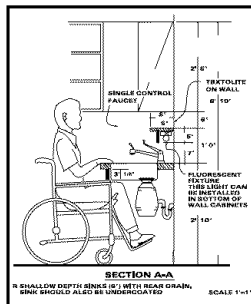

GE offers, free of charge, a brochure to assist in planning a barrier-free kitchen for persons with limited mobility.

Consumers with impaired hearing or speech who have access to a TDD or a conventional teletypewriter may call 800.TDD.GEAC (800.833.4322) to request information or service.

---

**Service Contracts**

**800.626.2224**

You can have the secure feeling that GE Consumer Service will still be there after your warranty expires. Purchase a GE contract while your warranty is still in effect and you'll receive a substantial discount. With a multiple-year contract, you're assured of future service at today's prices.

---

**Parts and Accessories**

**800.626.2002**

Individuals qualified to service their own appliances can have parts or accessories sent directly to their home. The GE parts system provides access to over 47,000 parts...and all GE Genuine Renewal Parts are fully warranted. VISA, MasterCard, and Discover cards are accepted.

User maintenance instructions contained in this manual cover procedures intended to be performed by any user. Other servicing generally should be referred to qualified service personnel. Caution must be exercised, since improper servicing may cause unsafe operation.



**YOUR MONOGRAM COOKTOP WARRANTY**

*Staple sales slip or cancelled check here. Proof of original purchase date is needed to obtain service under warranty.*

**WHAT IS COVERED**

*From the Date of the Original Purchase*

**FULL ONE-YEAR WARRANTY**

For one year from date of original purchase, we will provide, free of charge, parts and service labor in your home to repair or replace **any part of the cooktop** that fails because of a manufacturing defect.

.....  
This warranty is extended to the original purchaser and any succeeding owner for products purchased for ordinary home use in the 48 mainland states, Hawaii, Washington, D.C. or Canada. In Alaska the warranty is the same except that it is LIMITED because you must pay to ship the product to the service shop or for the service technician's travel costs to your home.

All warranty service will be provided by our Factory Service Centers or by our authorized Customer Care® servicers during normal working hours.

Should your appliance need service, during warranty period or beyond, in the USA call 800.444.1845. In Canada: 888.880.3030.

**WHAT IS NOT COVERED**

- Service trips to your home to teach you how to use the product.
- Replacement of house fuses or resetting of circuit breakers.
- Damage to the glass cooktop caused by the use of cleaners other than the recommended cleaning creams and pads.
- Damage to the glass cooktop caused by hardened spills of sugary materials or melted plastic that are not cleaned according to the directions in the Owner's Manual.
- Damage to the product caused by accident, fire, floods, or acts of God.
- Failure of the product if it is abused, misused, or used for other than its intended purpose or used commercially.
- Improper installation.
- Incidental or consequential damage caused by possible defects with this appliance.

Some states/provinces do not allow the exclusion or limitation of incidental or consequential damages, so the above limitation or exclusion may not apply to you. This warranty gives you specific legal rights, and you may also have other rights which vary from state to state/province to province. To know what your legal rights are in your state/province, consult your local or state/provincial consumer affairs office or your state's Attorney General.

**Warrantor in USA: General Electric Company,  
Louisville, KY 40225**

**Warrantor in Canada: Camco Inc.**

**Consumer Product  
Ownership Registration**  
Important Mail Today

*GE Appliances*



Place  
1st Class  
Letter  
Stamp  
Here

***General Electric Company***  
Warranty Registration Department  
P.O. Box 32150  
Louisville, KY 40232-2150

# Consumer Product Ownership Registration

Dear Customer:

Thank you for purchasing our product and thank you for placing your confidence in us. We are proud to have you as a customer!

Follow these three steps to protect your new appliance investment:

# 1

Complete and mail your Consumer Product Ownership Registration today. Have the peace of mind of knowing we can contact you in the unlikely event of a safety modification.

# 2

After completing this registration, write your model and serial numbers in this manual. You will need this information should you require service. The service number in the USA: 800.444.1845. In Canada: 1.888.880.3030.

# 3

Read your Owner's Manual carefully. It will help you operate your new appliance properly.

**Important:** To ensure that your product is registered, mail the separate product registration card. If the separate product registration card is missing, fold and mail the form below. No envelope is needed.

FOLD HERE

## Consumer Product Ownership Registration



Product  
Gas Cooktop

Model

Serial

Mr.  Ms.  Mrs.  Miss

First Name \_\_\_\_\_ Last Name \_\_\_\_\_

Street Address \_\_\_\_\_

Apt. # \_\_\_\_\_

City \_\_\_\_\_ State \_\_\_\_\_ Zip Code \_\_\_\_\_

Date Placed In Use Month \_\_\_\_\_ Day \_\_\_\_\_ Year \_\_\_\_\_ Phone Number \_\_\_\_\_-\_\_\_\_\_-\_\_\_\_\_



TAPE CLOSED



**Monogram.**

GE Consumer & Industrial  
Louisville, KY 40225

©2004 GE Company

164D4290P102-1  
49-80144-1

ZGU36GG 09-04 JR  
Printed in the United States