

Kenmore

SEWING MACHINE 19502



NER'S M

SEARS, ROEBUCK AND CO.

Dear Homemaker,

CONGRATULATIONS!

You have just purchased a Kenmore Sensor Sew 70, a sewing machine that can, with some easy setting by you, do both decorative and utility sewing more quickly and accurately than you ever dreamed possible. This machine can take the guesswork, the frustrating trial and error out of sewing, virtually eliminating hand-sewing. By just pressing a button or two, you can sew a seam or smock a dress, reinforce a sleeve or darn socks, create a border or embroider a sampler.

This manual will show you how to perform these wonders, making your sewing creations and crafts the "talk of the town", and make you the "star of the bazaar".

You can also program this machine to automatically sew your borders and monogram your clothing, and it will remember the entire sequence and repeat it when you press the foot control again.

Practice makes an expert ! Follow these directions and suggestions carefully. Get to know your machine intimately and it will turn your sewing tasks into an adventure !

These instructions will help you obtain the best sewing results and avoid unnecessary service expense for conditions beyond our control. Advice on the operation and care of your machine is always available at your nearest Sears Retail Store. Please remember, if you have questions about your machine, always mention the model number and serial number when you inquire.

Write them here, for easy reference: Model No. 385
Serial No. _____

TABLE OF CONTENTS

SECTION 1. KNOW YOUR MACHINE

A Portable Case or Cabinet is Available	4
Locate and Identify the Parts	5~6
Locate and Identify the Accessories	6

SECTION 2. PREPARE YOUR MACHINE FOR SEWING

Set Up the Machine	7~11
• Plug in the Machine and Switch on the Power	7
• Set the Foot Control	8
• Check Your Feed Balance Dial	8
• Set the Pressure Dial	8
• Adjust the Presser Foot Lever	9
• Thread Cutter	9
• Free-Arm Sewing: the Removable Extension Table	10~11
Know What the Presser Feet Will Do	12~15
• Foot Storage Compartment	12
• Presser Foot Types	13~15
A. Zigzag Foot	13
B. Transparent Buttonhole Foot	13
C. Overedge Foot	13
D. Quilter	14
E. Zipper Foot	14
F. Satin Stitch Foot	14
G. Blind Stitch Hem Foot	15
H. Straight Foot	15
J. Sliding Buttonhole Foot	15
Choose Your Needle and Thread	16~17
• Check Your Needle	16
• Fabric, Needle, Thread and Stitch Length Chart	17
• To Change Your Needle	17
Prepare the Bobbin	18~21
• Put Thread on the Spool	18
• Additional Spool Pin	18

• To Remove the Bobbin from the Machine	19
• Wind the Bobbin	19~20
• Insert the Bobbin into the Bobbin Holder	21
Prepare Your Top Thread	22~27
• Check Your Presser Foot	22
• Change the Presser Foot	23
• Thread Your Needle	24
• Pick Up Your Bobbin Thread	25
• Adjust the Top Thread Tension	26~27
For Straight Stitch	26
For Zigzag Stitch	27

SECTION 3. LEARN TO USE THE CONTROLS

Up/Down Needle Position Button	29
Control Panel	29
Pattern Indicator Screen	30
Pattern Selection Buttons	30
Memory Button	31
Clear Button	31
Straight and Zigzag Stitch Buttons	31
Stitch Width and Length Buttons	32~33
• Stitch Width Button	32
• Stitch Length Button	33
Reverse Stitch and Auto-Lock Buttons	34
• Reverse Stitch Button	34
• Auto-Lock Button	34

SECTION 4. PRACTICE COMMON STITCHING SKILLS

Use the Seam Guides	35
Turn a Square Corner	35
Sew on Heavy Fabrics	36
Use the Darning Plate	36
Basting 14	37
Darning 10	38

Sew a Button	39
Put in a Zipper	40~42

SECTION 5. LEARN THE STITCHES

Chart of Sewing Functions	44
Stitch Pattern Chart	45~49
Straight Stitches 10 ~ 13	50~55
• Straight Stitch	50
• Topstitching	51
• Position Your Needle for Topstitching	52
• Pintucking	53
• Quilting	54
• Gathering	55
Outline Stretch 11	56
Straight Stretch 12	57
Saddle Stitch 13	58
Zigzag Stitches 15 ~ 18	59~64
• Basic Zigzag 15	59
• Satin Stitch 15	60
• Overcasting Stitch 15	61
• Multiple Zigzag 16	62
• Overedge Seam 17	63
• Knit Stitch 18	64
Buttonholes 19 ~ 27	65~68
• Adjust the Stitch Density	68
Corded Buttonholes 19 ~ 21	69
Hemming and Edging Stitches 28 ~ 31	70~74
• Blind Hem Stitch (stretch) 28	71
• Blind Hem Stitch (woven) 29	71
• Shell Stitch 29	72
• Scallop Stitch 30	73
• Cut-Out Work Edging and Applique 31	74
Reinforcing Stitches 33 and 40	75~77
• Feather Stitch 33	75
• Fagoting Stitch 40	76

• Elastic Casing Stitch 40	77
Decorate with Geometric Patterns 34 ~ 39	78
Cross Stitch 41	79
Smocking 32 , 42 , 43 , 48	80
Sand Stitch 44	81
Program Decorative Stitch	
Patterns 45 ~ 47 etc.	82~84
• One Cycle Stitching	82
• Two Cycle Stitching	82
• Pattern Single Units	83
• To Adjust a Distorted Pattern	84
Monogramming 00 ~ 09 , 49 ~ 76	85~86
• Reduce the Size of Numbers and Letters	86

SECTION 6. PERFORMANCE PROBLEMS CHART

What to Do When	87~88
-----------------------	-------

SECTION 7. CARE FOR YOUR MACHINE

Replace the Light Bulb	89
Clean the Bobbin Holder	90
Clean the Hook Race and Feed Dogs	91
Oil the Underside	92
Oil the Face Cover Plate	92

PARTS LIST	93~94
------------------	-------

INDEX	95~96
-------------	-------

SECTION 1. KNOW YOUR MACHINE

A Portable Case or Cabinet is Available

A full line of sewing cabinets is available at your nearest Sears retail store or through our general catalog. Whenever you're ready to sew, so is your sewing place.

Another option . . . buy a Carrying Case . . . then your Kenmore goes anywhere, can be stored anywhere.

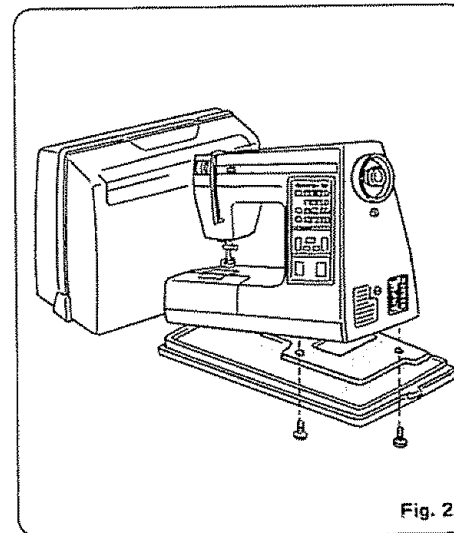
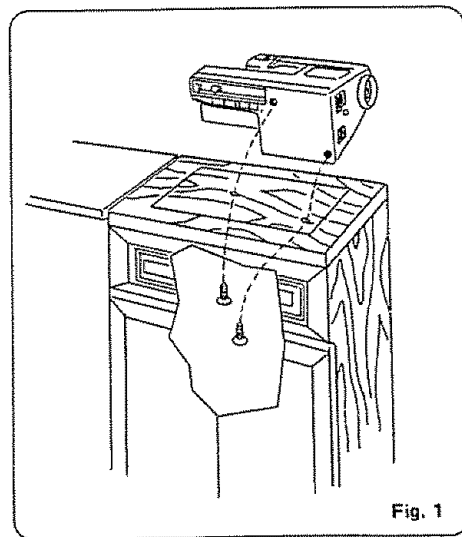

Locate and Identify the Parts

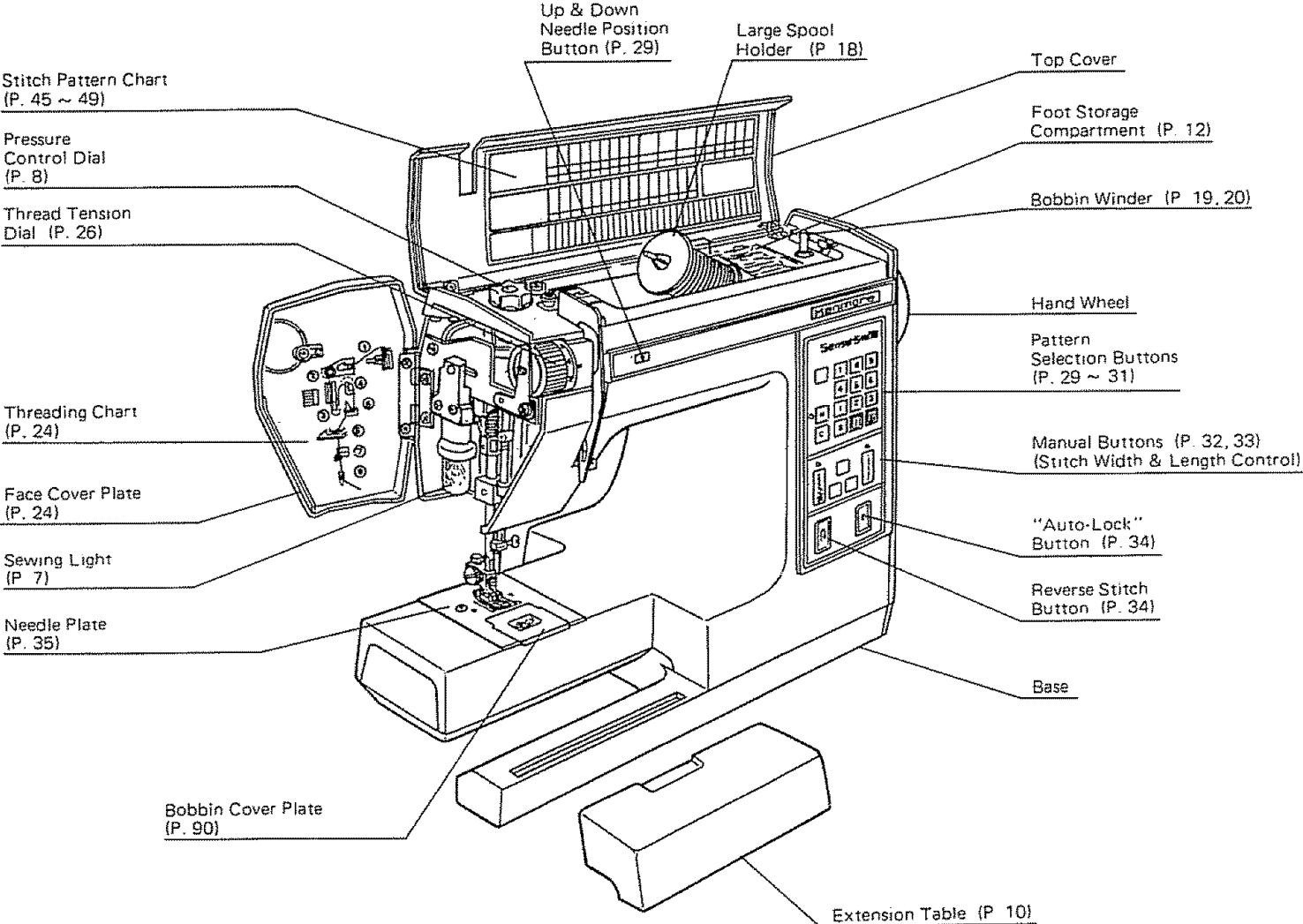

SECTION 1. KNOW YOUR MACHINE

Locate and Identify the Parts (Continued)

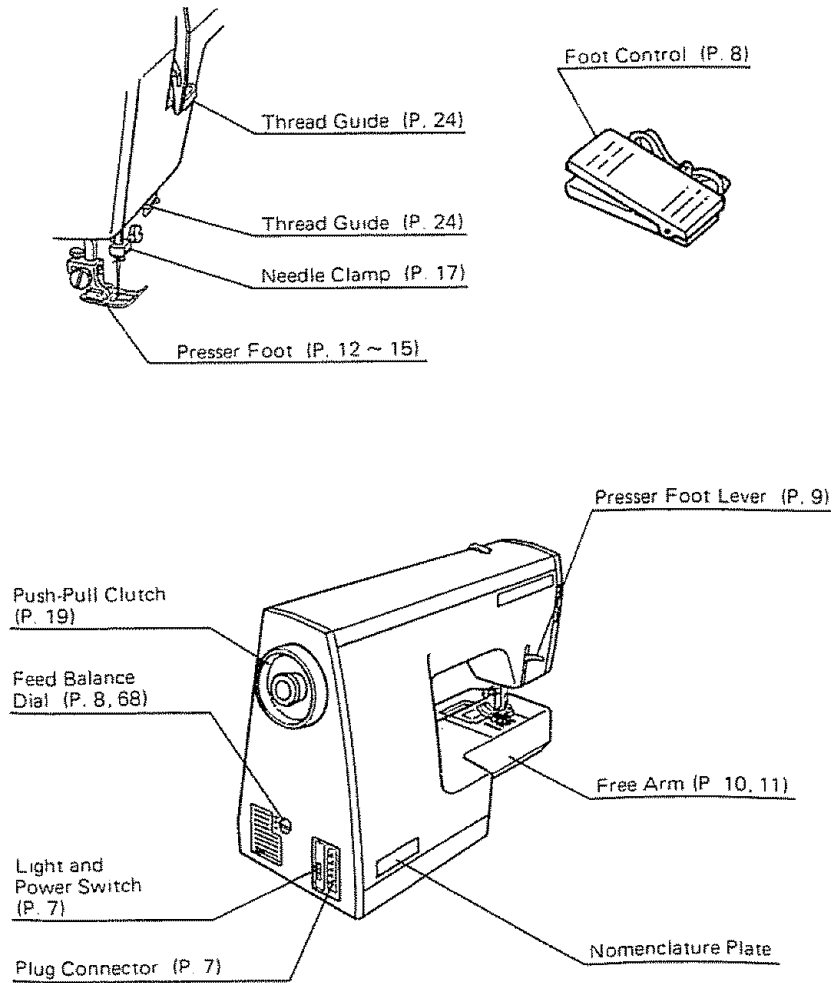

Locate and Identify the Accessories

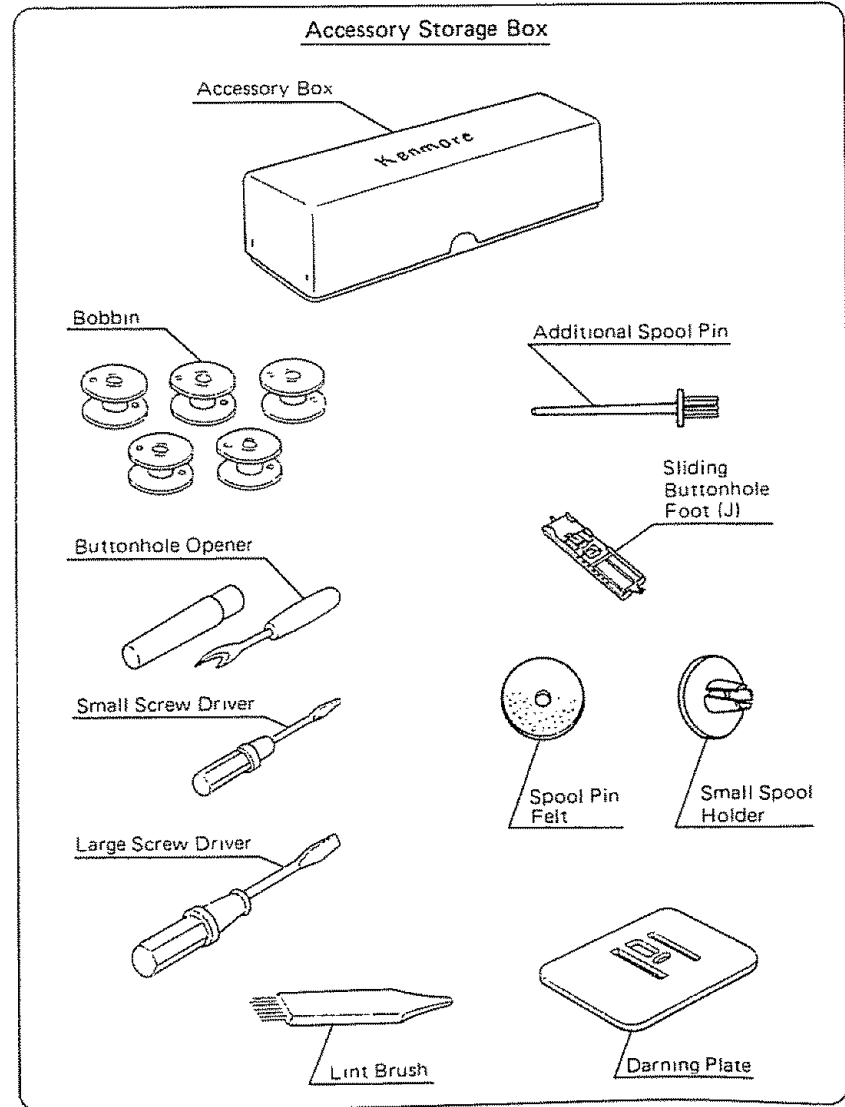

Set Up the Machine

• Plug in the Machine and Switch on the Power

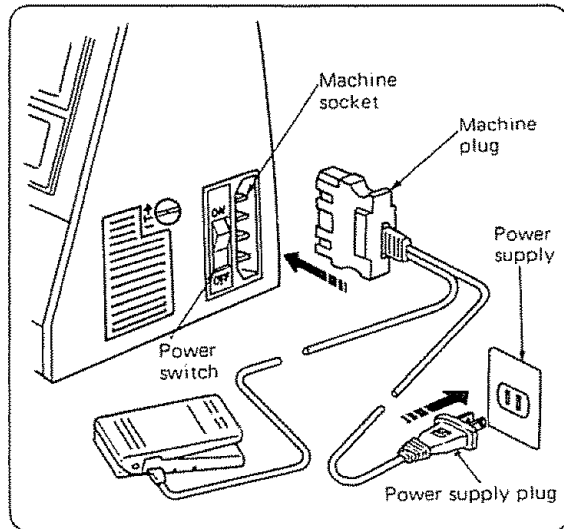

NOTE: Before inserting the plug into your machine, be sure the power switch is OFF.

1. Check your outlet to be sure it is a 110 to 120 Volt AC outlet.
2. Insert the machine plug into the five-prong outlet, as shown. It will only fit one way.
3. Insert the power supply plug into the outlet.
4. Push the light and power switch to turn on the power and sewing light.

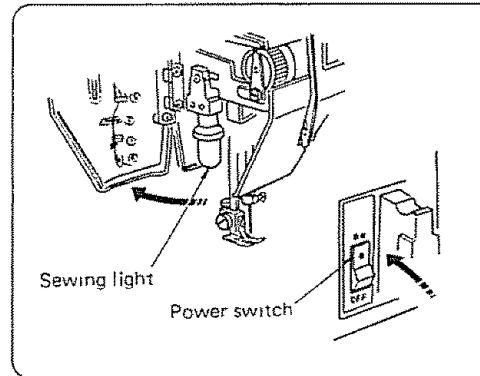

NOTE: The Pattern Indicator light will show **10**

SAFETY FEATURE:

Your machine will not operate unless the light/power switch is turned on. If you are interrupted or stop sewing, turn off the light/power switch to prevent injury to children.

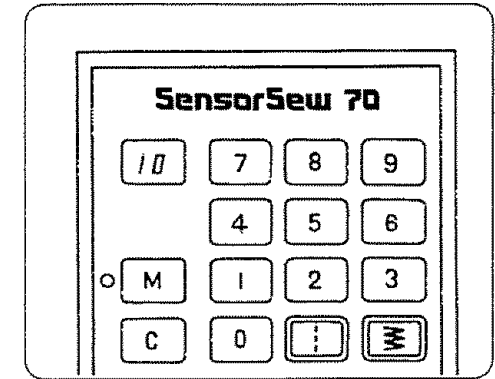

SECTION 2. PREPARE YOUR MACHINE FOR SEWING

Set Up the Machine (Continued)

• Set the Foot Control

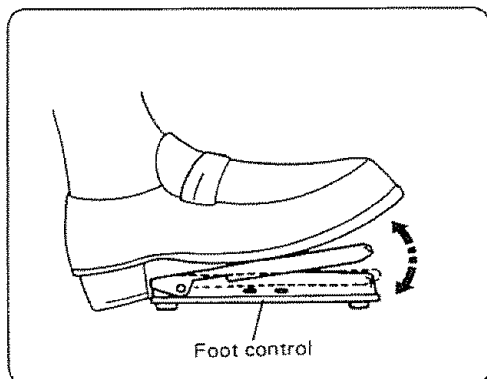

The foot control regulates the speed at which you sew.

Position the foot control as shown, with your heel on the floor.

To increase speed, gently press down with the ball of your foot.

To decrease speed, release your foot pressure slightly.

NOTE: The foot control is sensitive and will increase or decrease your sewing speed immediately. Practice on a scrap of fabric to regulate your sewing speed to your taste and needs.

• Check Your Feed Balance Dial

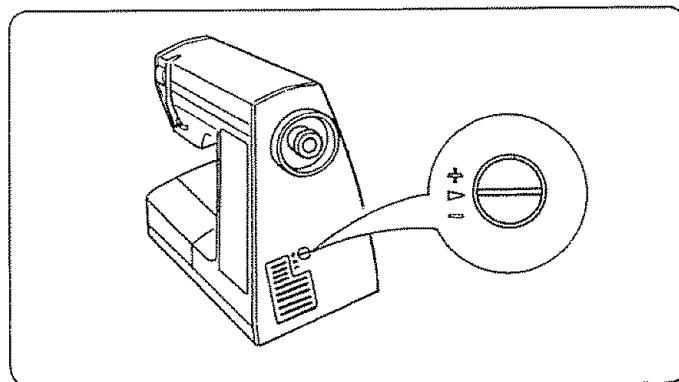

For most sewing, the groove in the Feed Balance Dial should point to the arrow ("▶").

You may rarely need to adjust the dial. But, if necessary, use this dial to regulate the feed balance for:

- * Buttonholes (See P. 68 for details)
- * Any "stretch" stitch such as patterns **17** , **18** , **30** ~ **33** , **40** ~ **48** and monogramming when sewing on very particular fabrics.

• Set the Pressure Dial

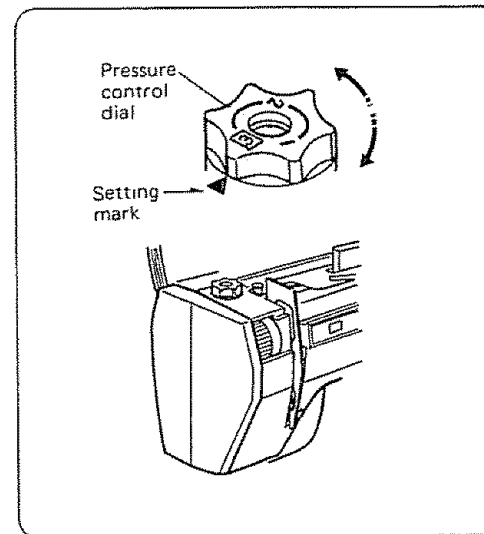

The Pressure Dial is located under the top cover.

Set as follows:

- 3** . . . most sewing
- 2** . . . applique and Cut-Out Work
- 1** . . . basting, sewing chiffon, lace, organdy and other lightweight fabrics
Also for velours and knits (with more stretch)

- Adjust the Presser Foot Lever

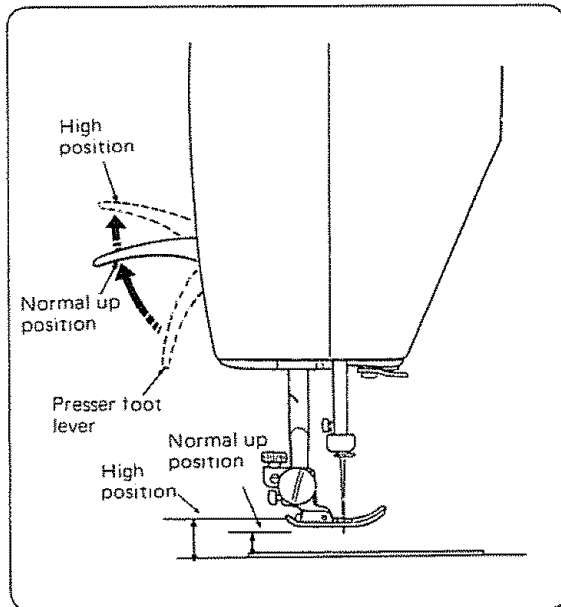

The Presser Foot Lever raises and lowers your presser foot.

You can raise it about 1/4" higher for easy removal of the presser foot or to help you place heavy fabrics under the presser foot.

- Thread Cutter

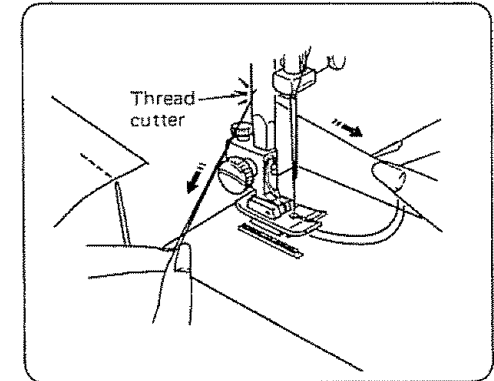
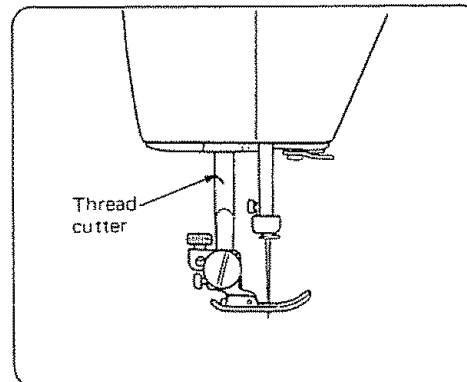

You don't need a scissors to cut the thread after you finish sewing. Just use the handy thread cutter on the back of the Presser Bar above the presser foot holder.

1. Pull thread through the groove until it is taut.
2. Then pull the thread sharply down and back to cut it.

SECTION 2 PREPARE YOUR MACHINE FOR SEWING

Set Up the Machine (Continued)

• Free-Arm Sewing: the Removable Extension Table

To remove:

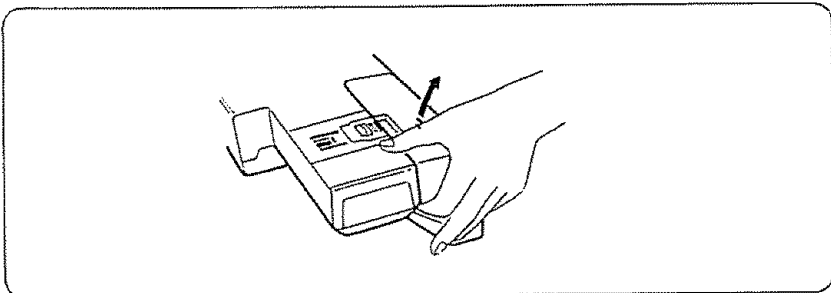

To Remove the Extension Table

(for free-arm sewing)

1. Grip the table with your index finger and thumb, as shown.
2. Pull gently toward you.
The extension table will snap out.

To Attach:

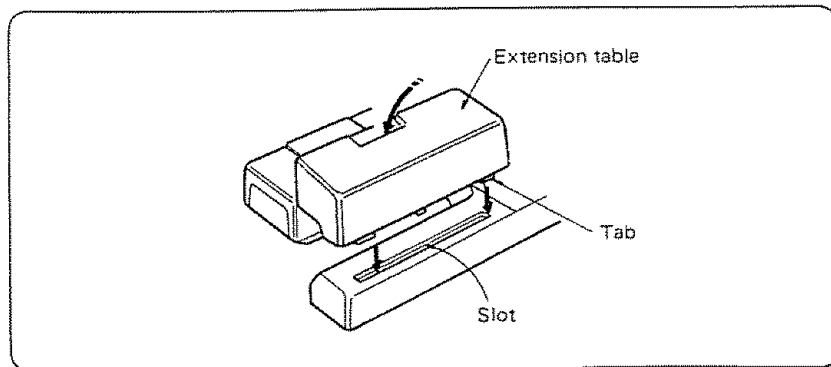

To Attach the Extension Table

(For flat-bed sewing)

1. Fit the tabs into the slot, as shown.
2. With your thumb and index finger, gently snap in.

Your Kenmore Sensor Sew 70 can do free arm sewing. This feature makes sewing easy for:

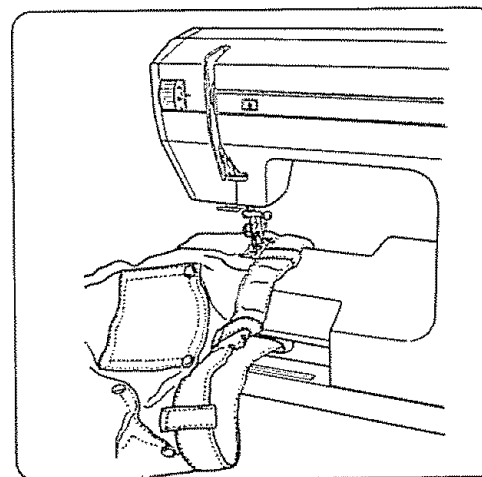

* bar tacking to reinforce pockets, plackets and waistlines on ready-made or homemade garments to avoid fabric bunching around the needle.

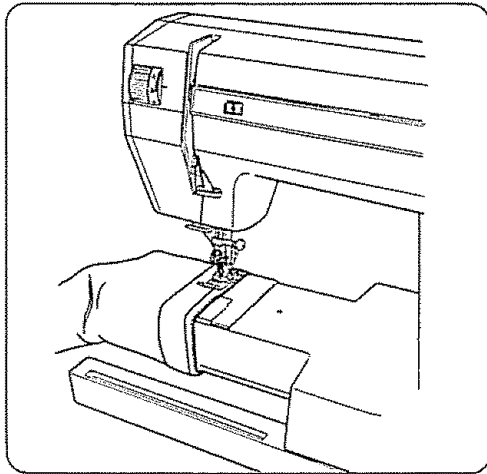

* Stitching sleeves, waistbands, pant legs, or any circular garment area.

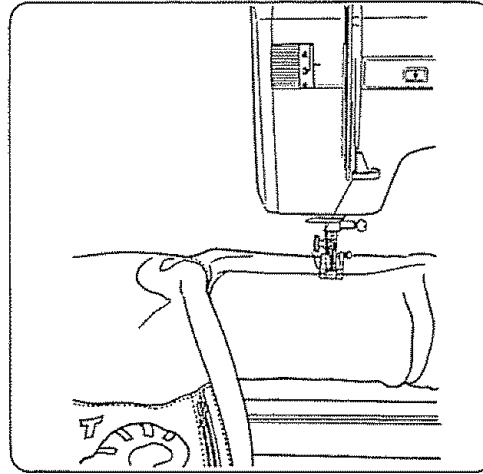

* darning socks or mending knees, elbows, or areas of wear in children's clothes.

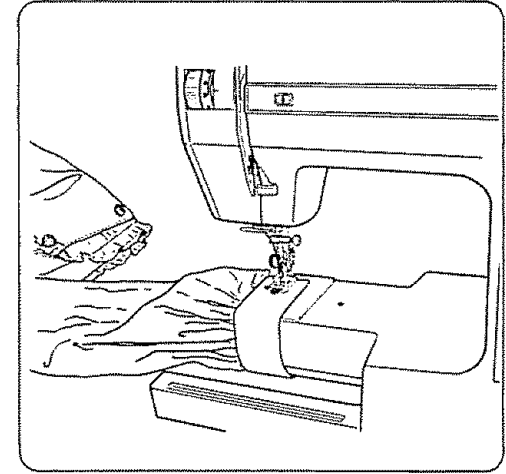

* sewing buttons on sleeves, waistbands, etc.

SECTION 2: PREPARE YOUR MACHINE FOR SEWING

Know What the Presser Feet Will Do

The Presser feet are an important feature of this machine. You need to know what each foot does in order to use them effectively.

Most of the presser feet are stored in the Foot Storage Compartment under the top cover.

NOTE: The numbers after each foot indicate the stitch patterns where you use the foot.

• Foot Storage Compartment

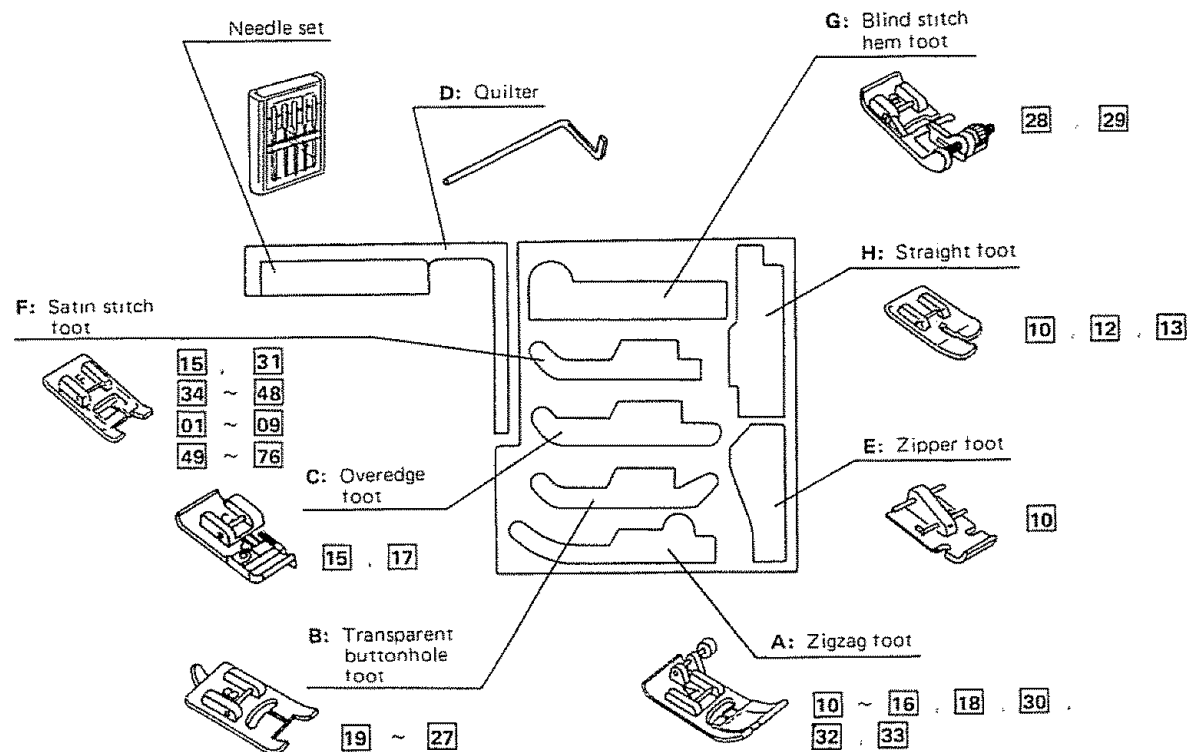

- Presser Foot Types

A. Zigzag Foot

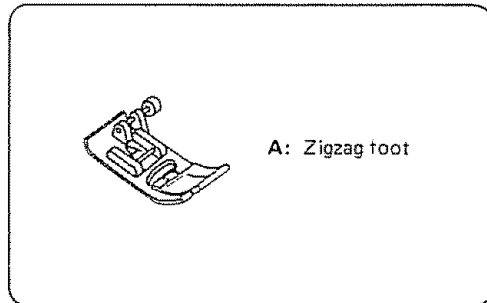

Use this foot for both straight and zigzag stitching.

The black button on the right side of the foot sets the foot to remain rigid so that you can sew on heavy fabrics. (See p. 36 for detailed instructions.)

Stitch Patterns:

10 ~ 16 , 18 , 30 , 32 , 33

B. Transparent Buttonhole Foot

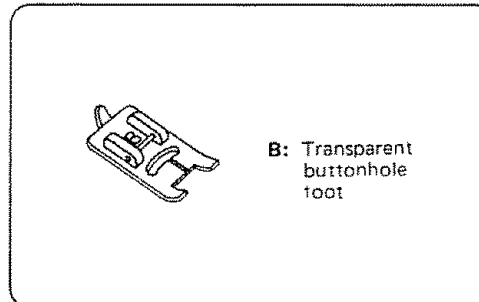

Use this foot to sew buttonholes when you want to control the fabric feed and buttonhole size beyond the limits of the sliding buttonhole foot.

Because the foot is transparent, you can see what you are sewing.

Stitch Patterns:

19 ~ 27

C. Overedge Foot

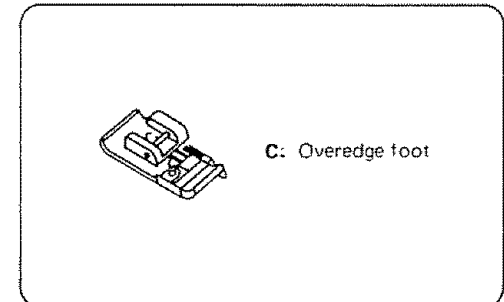

This foot is especially constructed for stitching and/or overcasting seams. The small brush and wire guides help control the fabric, hold the raw edge in place and keep it from puckering, especially when sewing on knit fabrics.

You may use this foot for the regular zigzag stitch 15 or with the overedge stitch 17. See p. 61, 63 for details.

Stitch Patterns:

15 , 17

SECTION 2 PREPARE YOUR MACHINE FOR SEWING

• Presser Foot Types (Continued)

D. Quilter

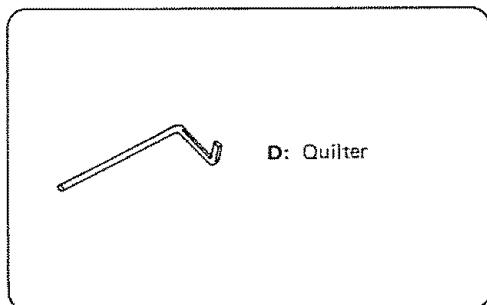

This attachment turns your zigzag foot into a quilting foot.

See p. 54 for detailed instructions.

Stitch Pattern: **10**

E. Zipper Foot

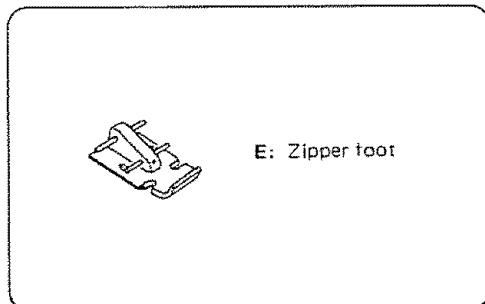

This foot can be set to sew on each side of your zipper. The edges of the foot guide the zipper and keep the seam straight.

For details on sewing zippers, see p. 40 ~ 42.

Stitch Pattern: **10**

F. Satin Stitch Foot

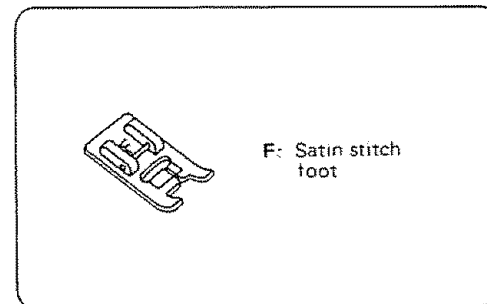

Use this transparent foot for outlining applique and Cut-Out Work, as well as for all your Decorative Stitching and monogramming.

Stitch Patterns:

15 , **31** , **34** ~ **48** , **01** ~ **09** ,
49 ~ **76**

G. Blind Stitch Hem Foot

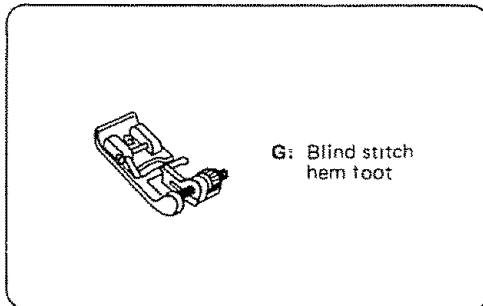

Use this foot for perfect blind hemming. The foot has ridges on the bottom to keep the fabric from slipping and a guide screw on top to guide the folded edge of your hem.

For detailed instructions, see p. 71.

Stitch Patterns: 28 , 29

H. Straight Foot

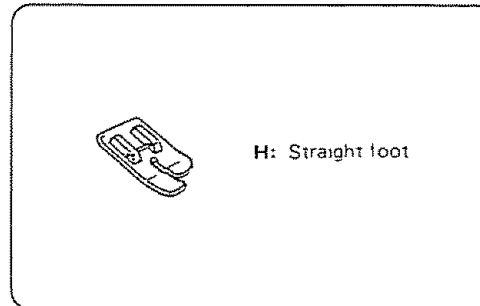

Use this foot exclusively for straight stitching.

Stitch Patterns: 10 , 12 , 13
(Center needle position)

J. Sliding Buttonhole Foot

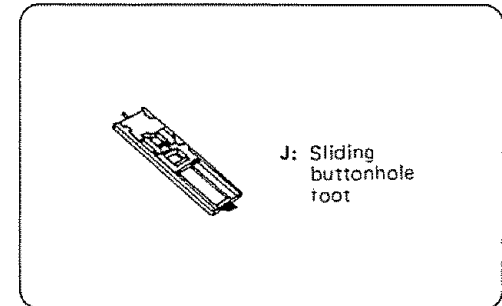

Use this foot for most buttonholes. It is marked to help you measure your buttonholes accurately. The maximum length of buttonhole that can be made by this foot is 1". For larger buttonholes, use the transparent buttonhole foot.

Stitch Patterns: 19 ~ 27

SECTION 2. PREPARE YOUR MACHINE FOR SEWING

Choose Your Needle and Thread

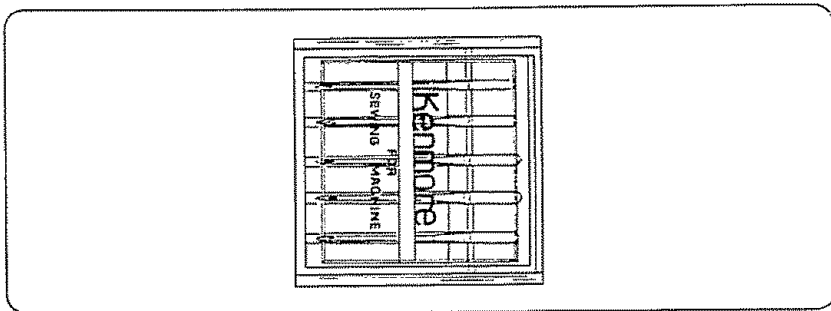

Your choice of needle and thread depends on the fabric you are sewing.

In your needle case, you will find the following color-coded needles:

- Blue (11) for stretch fabrics
- Orange (11) for lightweight fabrics
- Red (14) for medium or medium-heavy weight fabrics
- Purple (16) for medium-heavy weight and decorative topstitching on these fabrics
(This needle has a larger thread hole for thicker topstitching thread.)
- Green (18) for heavy weight fabrics and decorative topstitching on these fabrics

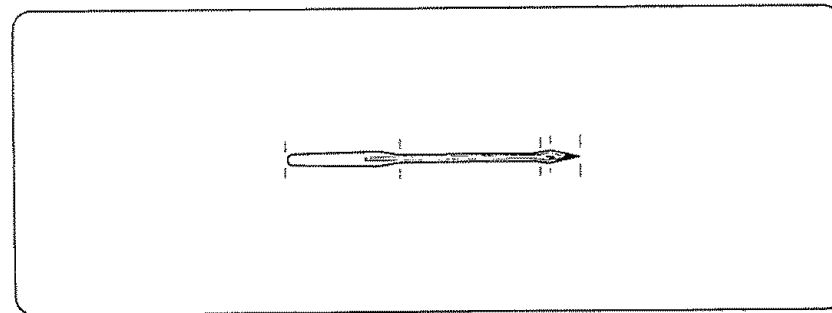

Specialty needles are also available.

- Denim Needle for sewing dense fabrics such as denim or canvas.
- Topstitching Needle its larger eye will hold heavier thread.
- Leather Needle punches tiny holes in leather and suede.

When buying needles other than Kenmore needles, be sure the needle fits the length and shape of the needle shown above. A longer or shorter needle will skip stitches or break.

• Check Your Needle

1. Look for barbed or blunt point.
2. A damaged needle can cause permanent snags or runs in knits, fine silks and silk-like fabrics.

Always buy a good quality thread. It should resist tangling and be strong, smooth and consistent in thickness.

SECTION 2: PREPARE YOUR MACHINE FOR SEWING

• Fabric, Needle, Thread and Stitch Length Chart

FABRIC	NEEDLE SIZE AND COLOR	THREAD SIZE	RECOMMENDED STITCH LENGTH SETTING
Lightweight: Batiste, Dimity, Chiffon, Silks, Fine Lace, Organza, Crepe, Taffeta, Voile, Organdy	11-ORANGE	Polyester Core/Cotton Wrap Fine Mercerized Cotton Silk A	2.0 (12 stitches per inch)
Medium Weight: Cotton, Cotton Blends, Percale, Gingham, Shantung, Pique, Seersucker, Satin, Knits, Vinyl Suitings, Linen, Wool Crepe, Leather	14-RED	50 Mercerized Cotton Polyester Core/Cotton Wrap Silk A	2.0 ~ 2.5 (10 ~ 12 stitches per inch)
Medium Heavy Weight: Corduroy, Denim, Wool, Sailcloth, Wool Flannel, Gabardine, Velvets, Leather	14-RED or 16-PURPLE	50 Mercerized Cotton Mercerized Heavy-Duty Polyester Core/Cotton Wrap Silk A	2.5 ~ 3.0 (8 ~ 10 stitches per inch)
Heavy Weight: Coatings, Upholstery Cotton Duck, Heavy Twills, Canvas	18-GREEN	Heavy Duty Mercerized Cotton Polyester Core/Cotton Wrap Silk A	3.0 (8 stitches per inch)
Decorative top-stitching on all types of fabric	16-PURPLE 18-GREEN	Buttonhole Twist (Use as top thread only)	4.0 ~ 4.5 (4 ~ 6 stitches per inch)
Stretch Fabric: Polyester Double Knits, Nylon Tricot, Jersey, Stretch Terry, Spandex, Cire Tricot	11-STRETCH FABRIC NEEDLE- BLUE	Polyester Core/Cotton Wrap 50 Mercerized Cotton	2.0 ~ 2.5 (10 ~ 12 stitches per inch)

• To Change Your Needle

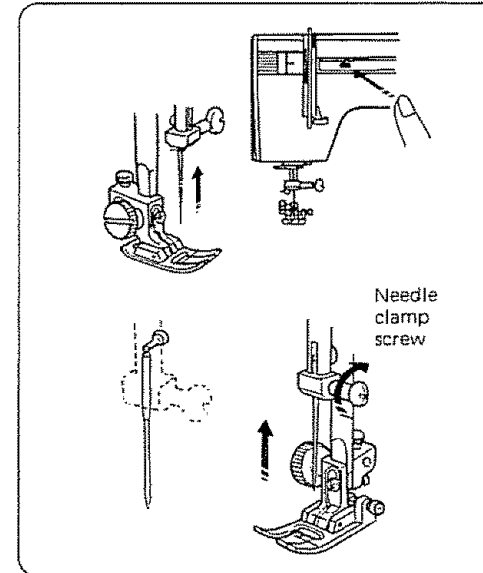

NOTE: Raise the needle bar to its highest position by pressing the Up/Down Needle Position Button:

1. Loosen the needle clamp screw by turning it toward you.
2. Remove the needle by pulling it downward.
3. Insert the new needle into the needle clamp with the flat side away from you.
4. Push the needle up as far as it will go.
5. Tighten the needle clamp screw firmly with the large screwdriver from your accessory box.

SECTION 2. PREPARE YOUR MACHINE FOR SEWING

Prepare the Bobbin

• Put Thread on the Spool

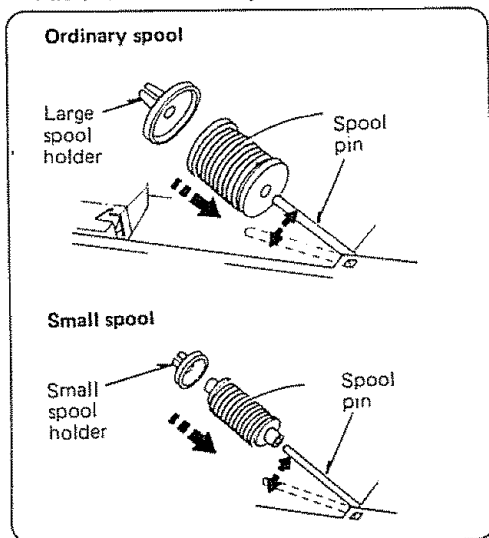

NOTE: Your spool pin tilts upward for ease in putting thread on the spool.

You have two spool holders:

large (under the top cover) and small (in your accessory box).

1. Choose the appropriate spool holder.
2. Place your thread on the spool pin and then fit the spool holder down over it, so that the thread winds toward the back of the machine, as shown.
3. Press the spool holder against the spool.
4. Lower the spool into the well.

• Additional Spool Pin

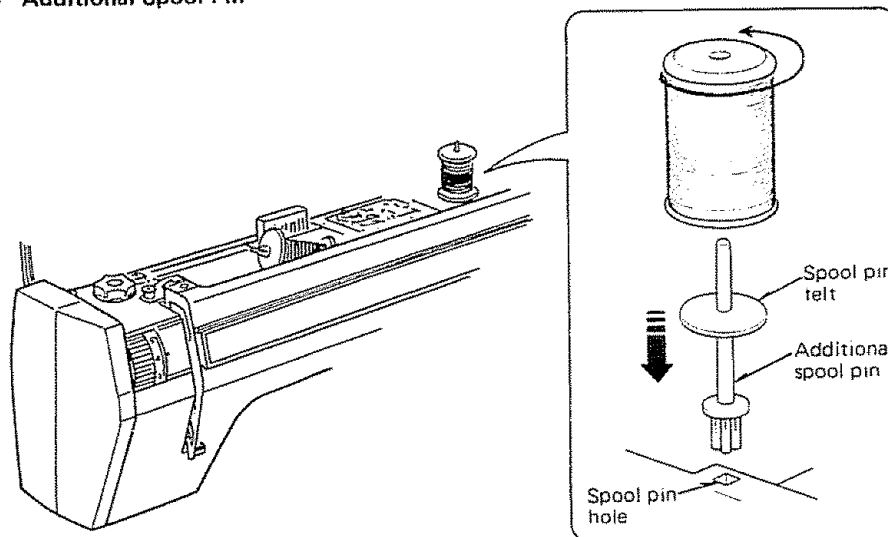

NOTE: For winding the bobbin while your machine is threaded, you have an extra spool pin in your accessory box. It fits into the square hole on top of your machine near the bobbin winder.

To Use This Extra Spool Pin:

1. Fit the square end of the spool pin into the square hole, as shown.
2. Fit the spool pin felt on the base of the spool pin.
3. Put your spool of thread on top of the felt, with the thread winding in the direction shown. See directions for winding the bobbin, p. 19 ~ 20.

SECTION 2. PREPARE YOUR MACHINE FOR SEWING

• To Remove the Bobbin from the Machine

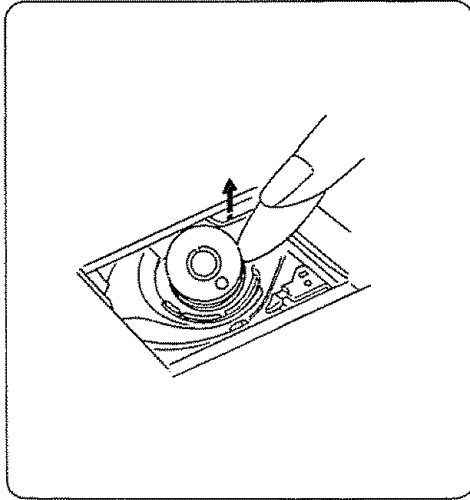

1. Gently push down on the plastic bobbin cover and slide it towards you.
2. Set aside.
3. Lift out the bobbin, as shown.

• Wind the Bobbin

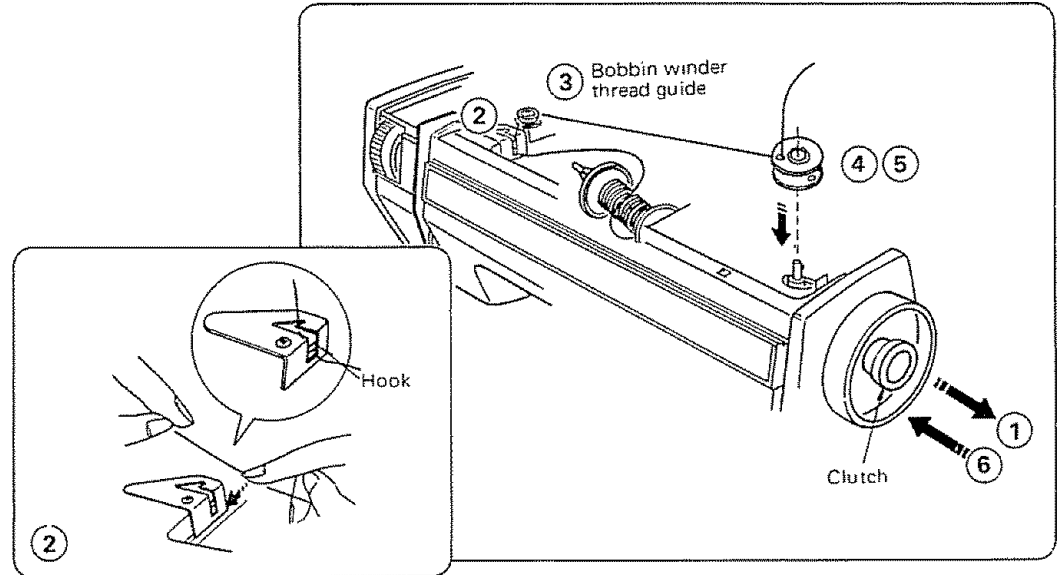

1. Pull the Clutch away from the machine to stop the needle from moving while you wind the bobbin.
2. Pass the thread through the top cover thread guide and under the hook, as shown.
3. Pull the thread around the bobbin winder thread guide.
4. Place the thread through one of the bobbin holes, from inside to outside, as shown.
5. Place the threaded bobbin on the bobbin winder spindle, as shown, so that the thread comes out on top.
6. Push the bobbin winder spindle to the right until it clicks.

SECTION 2: PREPARE YOUR MACHINE FOR SEWING

Prepare the Bobbin (Continued)

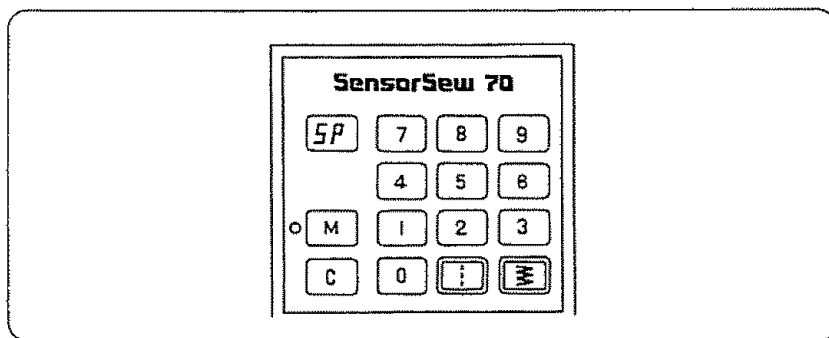

NOTE: The Pattern Indicator will read "SP" to show the machine is winding the bobbin.

7. Press the foot control gently to start the machine.

NOTE: After the bobbin is slightly filled, stop and clip the thread coming from the top of the bobbin.

8. Slowly start the machine again and wind the thread until the bobbin stops.

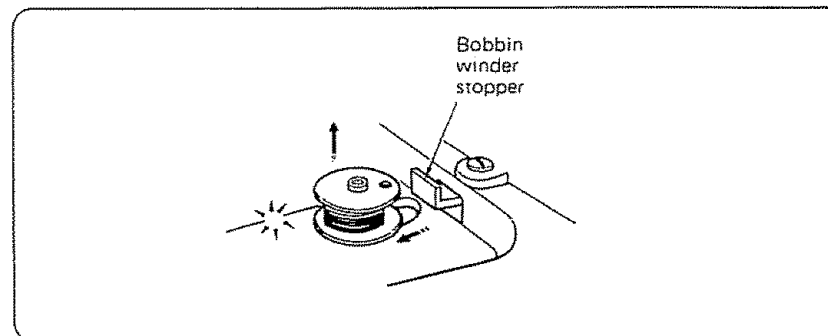

9. Push the bobbin winder spindle to the left and clip the thread.

10. Remove the bobbin.

11. Push in the clutch to put power back into the needle.

NOTE: If you do not push in the clutch, the machine will not run when you press the foot control.

- Insert the Bobbin into the Bobbin Holder

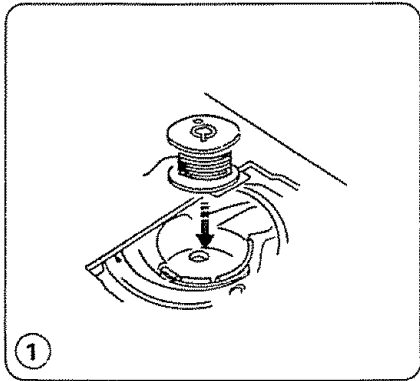

1. Put the bobbin into the bobbin holder so that the thread feeds counter-clockwise (left).

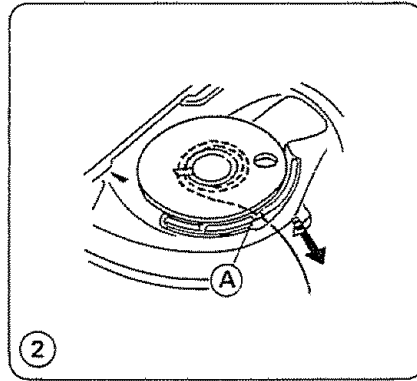

2. Pull about 4 inches of thread toward you through the tension slot **(A)**.

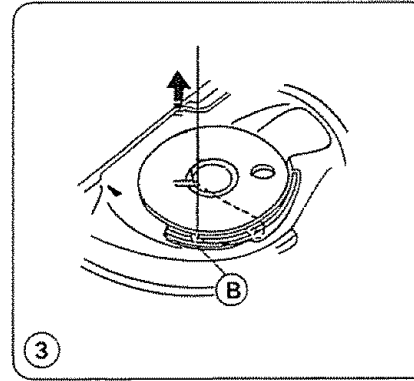

3. Then pull the thread clockwise toward the back of the machine through the slot **(B)**.

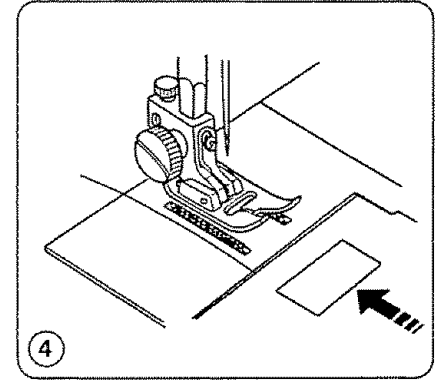

4. Slide the bobbin cover plate over the bobbin. Allow about 4 inches of thread to show above the needle plate.

SECTION 2. PREPARE YOUR MACHINE FOR SEWING

Prepare Your Top Thread

- Check Your Presser Foot

Your presser foot is held in place by a Foot Holder. Each presser foot merely snaps on the foot holder, which is seldom removed.

If you need to remove or attach the foot holder, here is what you do:

To Remove:

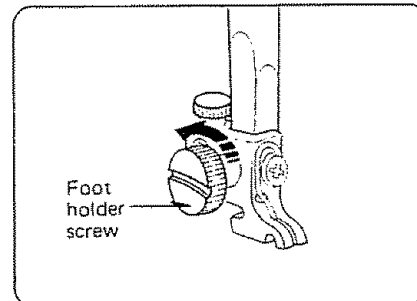

To Remove:

Turn the screw toward the back of the machine. Use the large screw driver.

To Attach:

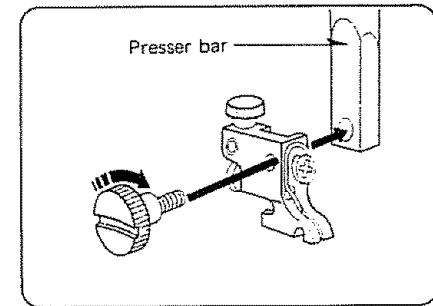

To Attach:

1. Match the hole in the foot holder with the threaded hole in the presser bar.
2. Fit the foot holder screw into the hole.
3. Tighten the screw by turning it toward you.

- **Change the Presser Foot**

Use the correct presser foot for the stitch you wish to sew. Consult the Stitch Pattern Chart and the detailed directions for sewing with the various presser feet.

To snap off

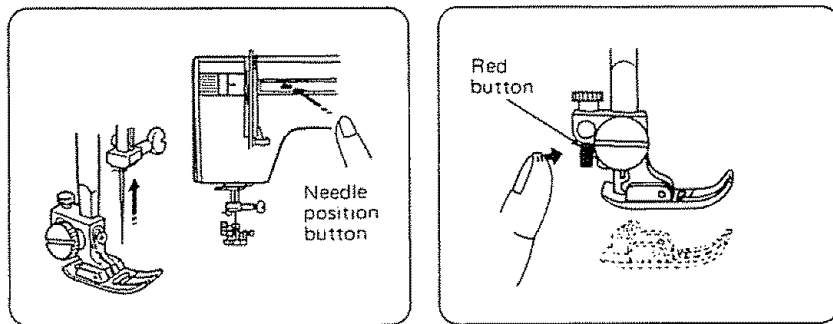

To Snap Off the Presser Foot:

1. Press the Up/Down Needle Position Button to raise the needle to its highest position.
2. Raise the presser foot.
3. Press the red button on the back of the foot holder. The presser foot will drop off.

To snap on

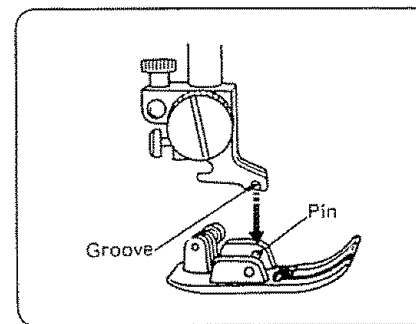

To Snap On the Presser Foot:

1. Set the Pressure Dial at "3".
2. Place the presser foot so the horizontal pin on the foot lies just under the groove of the foot holder.
3. Lower the presser foot holder to lock the presser foot in place.

NOTE: If you do not hear the presser foot snap in place, press down on the presser foot holder firmly until you hear the snap.

SECTION 2 PREPARE YOUR MACHINE FOR SEWING

Prepare Your Top Thread (Continued)

• Thread Your Needle

NOTE: The numbered steps below follow the numbers on the illustrations.

NOTE: Dotted lines show places where the thread loops and then is pulled tight. Each place has a spring.

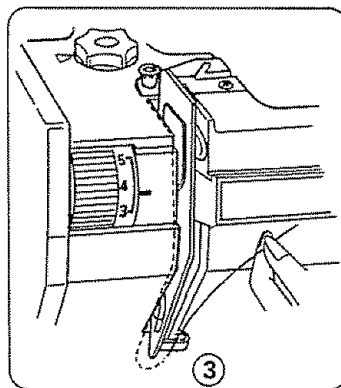
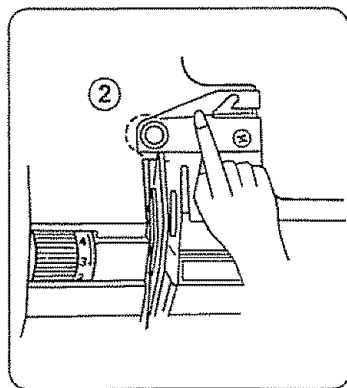
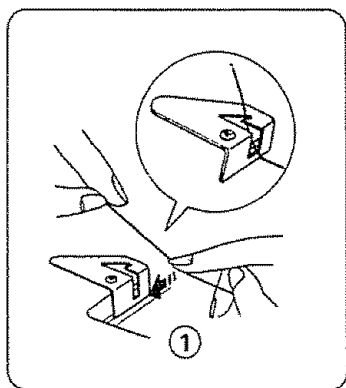

1. Hold the thread, as shown. Press the thread down until it clicks and comes down under the hook in the top cover thread guide.
2. Draw the thread around the thread guide and down into the tension area.
3. Pull the thread up from left to right around the check spring wire.
4. Draw the thread straight up and from left to right through the slot and into the eye of the take-up lever.

5. Draw the thread down and slip it through the right side of the right-hand thread guide, as shown.
6. Pull the thread to the left and slip it through the left thread guide.
7. Slide the thread through the needle bar guide on the left.
8. Thread the needle from front to back.

NOTE: You may want to cut the end of the thread with sharp scissors for easier needle threading.

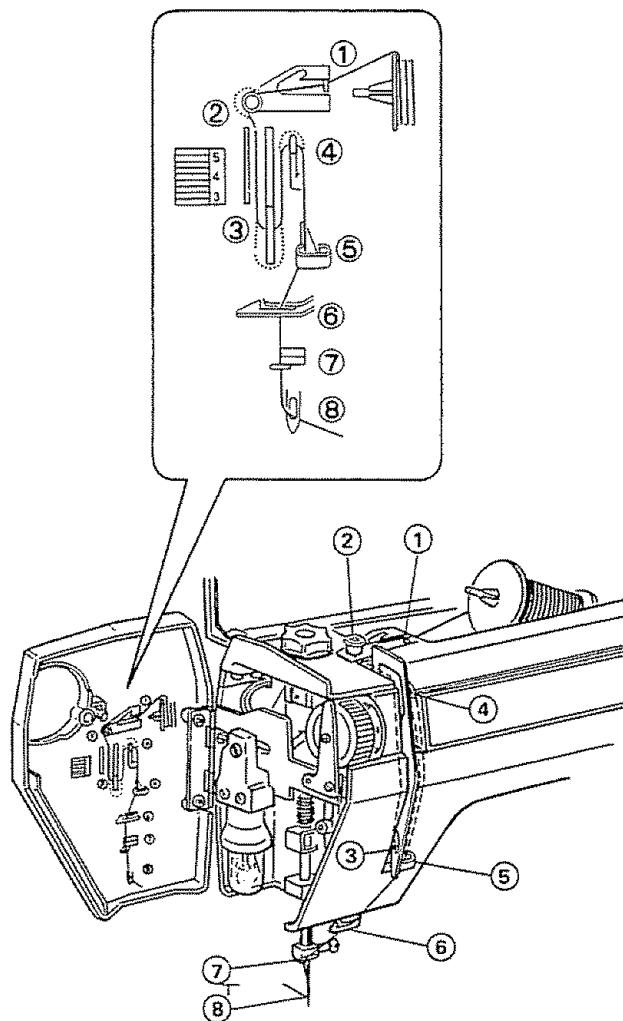

• Pick Up Your Bobbin Thread

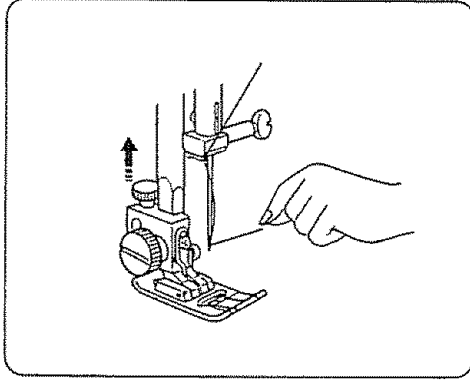

1. Hold the top thread lightly with your left hand.

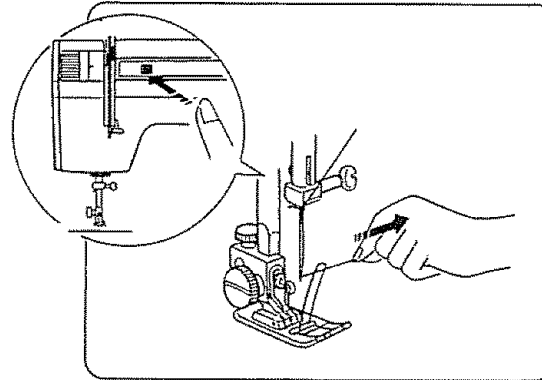

2. Press the Up/Down Needle Position Button twice.
3. Bring the bobbin thread up by pulling the top thread.

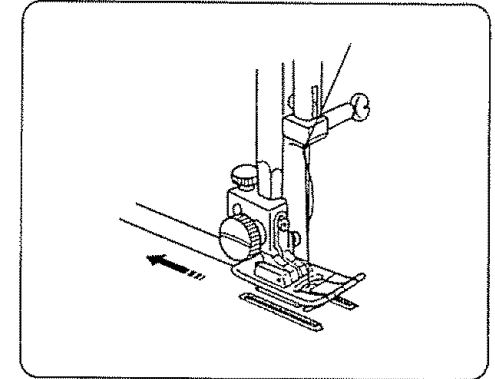

4. Pull both threads under and back of the presser foot. Leave 3 to 4 inches of thread clear.

SECTION 2. PREPARE YOUR MACHINE FOR SEWING

Prepare Your Top Thread (Continued)

• Adjust the Top Thread Tension

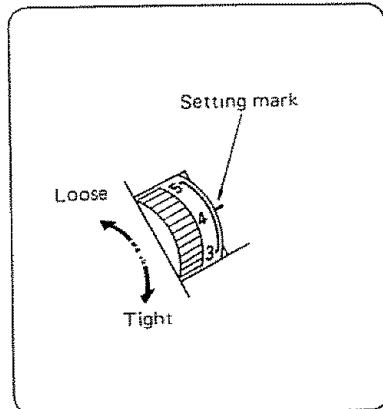
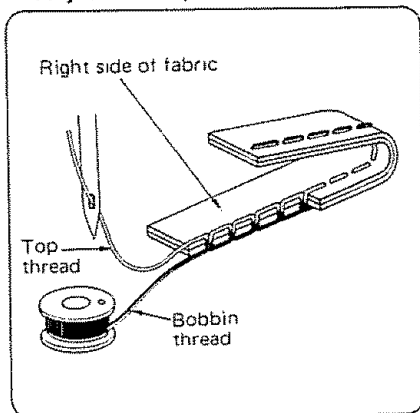

For Straight Stitch

The ideal straight stitch will have threads locked between the two layers of fabric, as shown above, magnified to show detail.

If you look at the stitch, front and back, you will notice that there are no gaps, that each stitch is smooth and even.

Choose the Correct Tension:

The best tension will depend on;

- the stiffness and thickness of the fabric
- the number of fabric layers
- the type of stitch

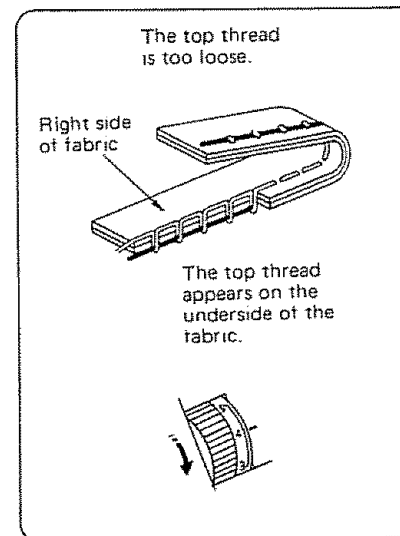

Tension is too loose:

The top thread shows through the bottom of the fabric. The bottom side of the stitch will feel bumpy.

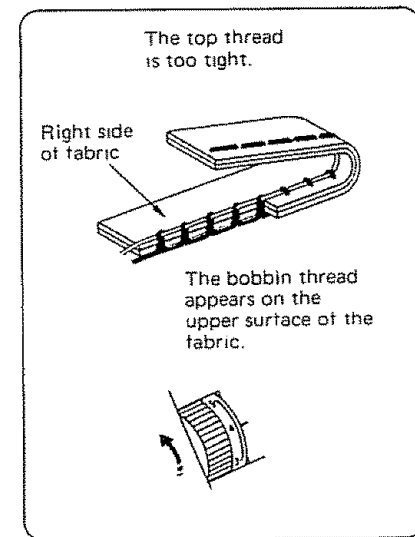

Tension is too tight:

The bobbin thread will come through the top of the fabric. The top side of the stitch will feel bumpy.

For Zigzag Stitch

Check the tension of your zigzag stitch by sewing a zigzag stitch **15** on fabric you plan to use. Also use the type of thread you will be using, but put different colors on the bobbin and the upper spool.

In the ideal zigzag stitch, the bobbin threads will not show on top of the fabric. See below for the correct appearance. To match this appearance, adjust your top thread tension.

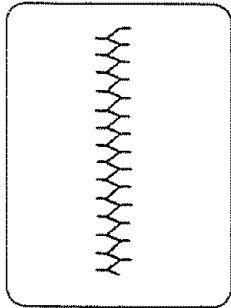
Too Tight

Right Side of Fabric

Too Tight:

— The points of the zigzag will pull together on top of the stitch.

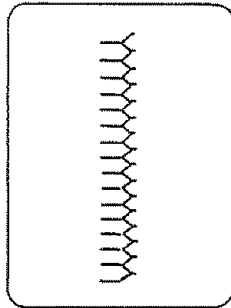
Too Loose

Wrong Side of Fabric

Too Loose:

— The top thread will loop through the points on the bottom of the stitch.

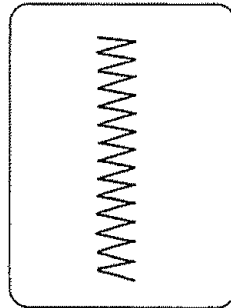
Just Right

Right Side of Fabric

SECTION 3. LEARN TO USE THE CONTROLS

The Illustration shows the Up/Down Needle Position Button and the control panel of your Kenmore Sensor Sew 70. The control buttons, indicator lights and indicator screens enable you to control your machine and know what it is doing at all times.

In this section, you will learn what these buttons are and how to use them. Each time you press a control button you will hear a "beep". Practice using these controls to see what they will do.

Let's look carefully at each control button, beginning with the Up/Down Needle Position Button and continuing down the Control Panel.

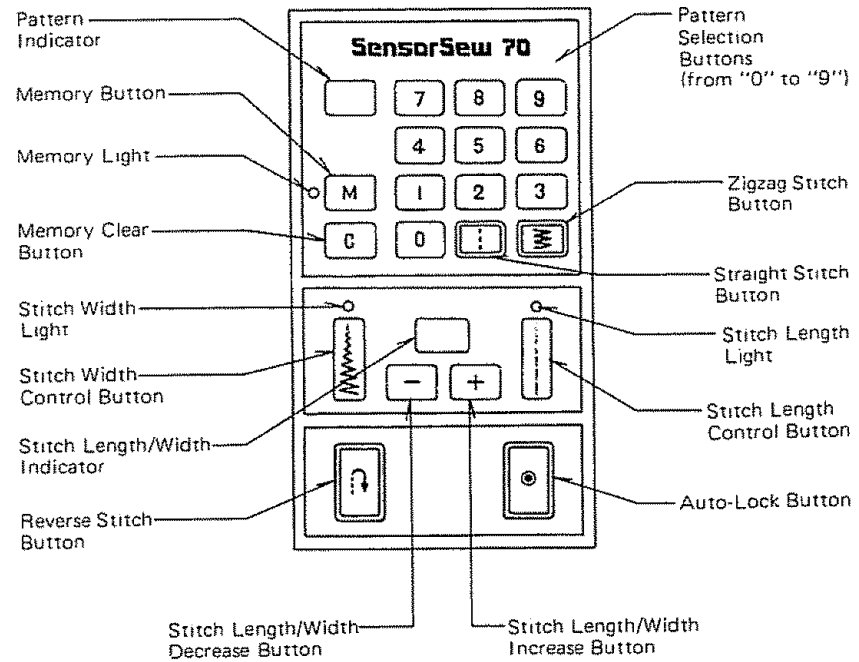
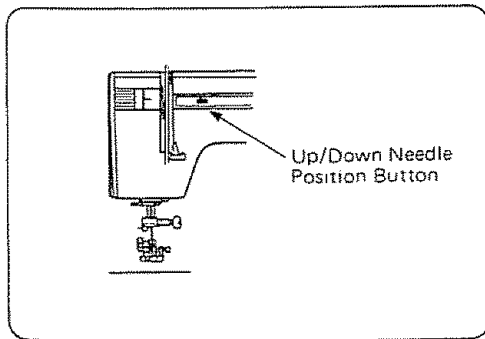

Up/Down Needle Position Button

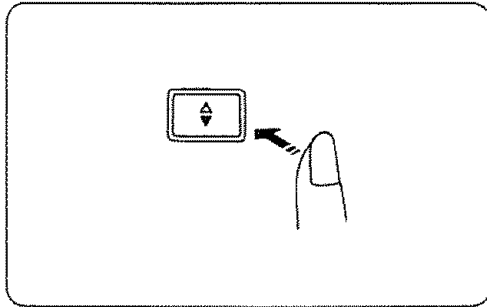

When you press this button, the needle will go up or down.

If the needle is up and you press this button, the needle will go down to its lowest position.

If the needle is down and you press this button, the needle will go to its highest position.

CAUTION: Do not press the foot control while you press the up/down needle position button.

Use this button to:

- take up the bobbin thread (down and up) as you hold the top thread
- turn a corner (down to keep the fabric from slipping)

It eliminates the hand wheel for raising and lowering the needle.

Control Panel

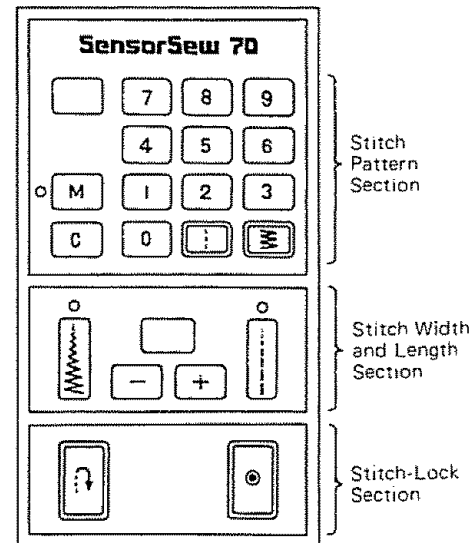

The Control Panel is divided into three sections:

The Stitch Pattern Section,

where you set stitch patterns, with memory and clear buttons, and convenient straight and zigzag stitch buttons.

The Stitch Width and Length Section,

where you set the length of straight stitches and the length and width of zigzag stitches.

The Stitch-Lock Section,

with the Reverse and Auto-Lock buttons to secure your stitches either manually or automatically.

SECTION 3 LEARN TO USE THE CONTROLS

Pattern Indicator Screen

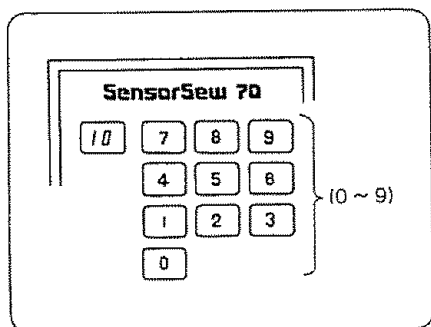

This two digit indicator screen lights up to show what stitch pattern you are using.

NOTE: When you turn on your machine, the indicator will automatically show the straight stitch **10**.

To Select a Stitch Pattern:

1. Press two numbers to indicate which pattern you want to use.
2. The numbers will show on the pattern indicator screen.

Pattern Selection Buttons

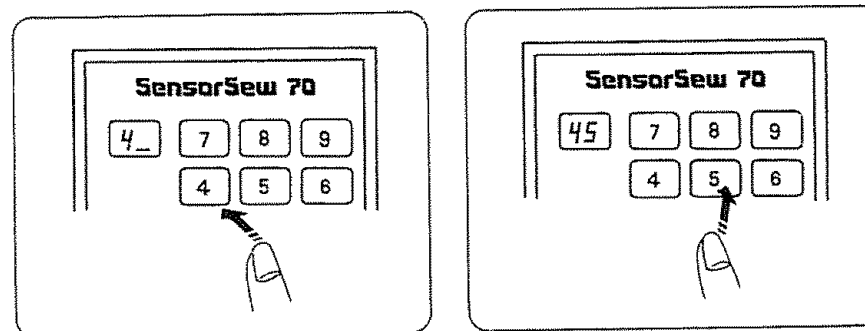

You use these buttons to select a stitch pattern. They run from 0 to 9.

Example: You want to use decorative stitch **45**.

1. Press **4**. A number 4 and a flashing line will appear on the pattern indicator screen.
2. Press **5**.

You have selected stitch pattern **45**.

NOTE: If you select numbers not on the stitch pattern chart (See inside machine top cover and p. [45 to 49](#)), the machine will blink until you select numbers on the chart.

Memory Button

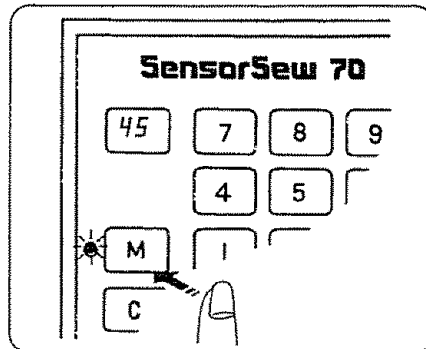

The Memory Button, with its memory indicator light, will “memorize” your pattern selection. Your machine can remember up to 31 stitch patterns, including the Auto-Lock, which automatically reinforces or locks the stitch you have chosen. This button is most typically used when monogramming or combining patterns.

To Set the Memory:

Press the Memory Button after you select your stitch pattern. The memory indicator light will go on to show that the machine has recorded your selection.

NOTE: If you are selecting a series of different stitch patterns, you must press the memory button after each selection. The Sensor Sew 70 will remember them in order.

Clear Button

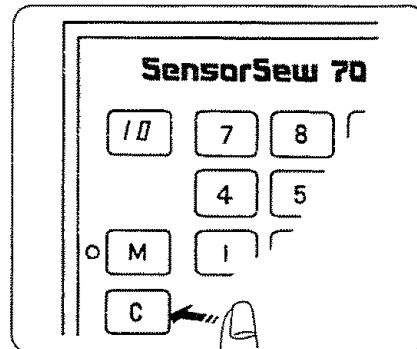

The Clear Button will erase the stitch pattern you have selected and automatically return your machine to **10**: the straight stitch pattern.

The Clear Button works in two ways to clear a series of stitch patterns, depending on whether you have pressed the foot control.

Foot Control Not Pressed:

The Clear Button clears one stitch pattern at a time, beginning with the last selected and ending with the first selected until it comes to “10”. This allows you to correct any mistakes you may make while programming a series of patterns.

Foot Control Pressed:
(even if only one stitch)

The Clear Button deletes all stitch patterns in the series at once. You see a **10** right away.

Straight and Zigzag Stitch Buttons

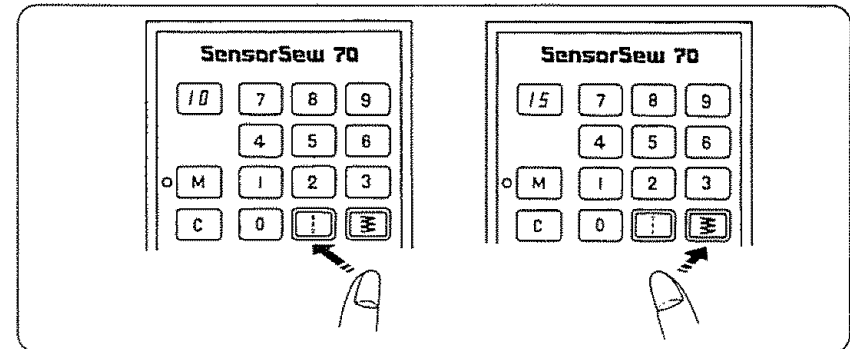

You can set each of these most used stitches by pressing just one button: Straight or Zigzag. The pattern indicator screen will show **10** (Straight) or **15** (Zigzag).

SECTION 3 LEARN TO USE THE CONTROLS

Stitch Width and Length Buttons

All stitches in your Sensor Sew 70 are pre-set for the best stitch length and width, but if you wish to change the settings here's how:

You can set stitch width and length with these two buttons. (Use one at a time. The machine will remember the first one while you set the other, without your having to press the memory button.)

Use the Plus "+" or minus "-" buttons to increase or decrease the stitch width or length.

The indicator screen will show the stitch width or length you have selected.

• Stitch Width Button

This button controls the width of zigzag stitches.

NOTE: If you press the stitch width button while doing straight stitching, the stitch width light will go on and the indicator screen will show "C". Your needle is in the "Center". If you press the "+" button, the indicator will show "R" (Right). If you press the "-" button, the indicator will show "L" (Left).

When you press this button for zigzag stitches, the stitch width light will go on and the indicator screen will show the preset stitch width of "5.0".

NOTE: The range of stitch width depends on the stitch pattern you select.

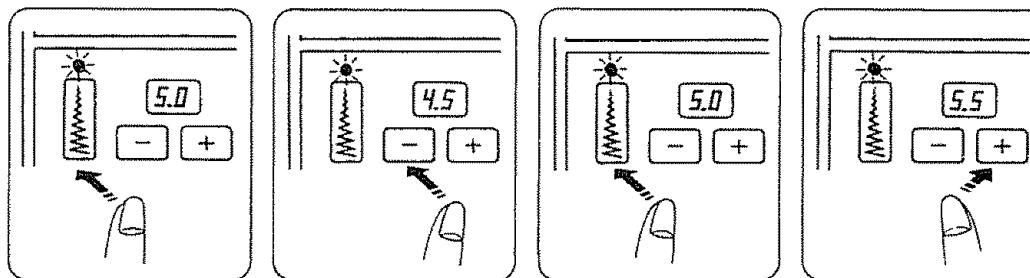

To Decrease the Stitch Width:

Press the "-" button. The width will decrease by 0.5 mm to "0.0" each time you press the button.

To Increase the Stitch Width:

Press the "+" button. The zigzag width will increase by 0.5 mm up to "7.0" each time you press the button.

To Adjust the Stitch Width Quickly:

Hold Down the "-" or "+" button until you reach the stitch width you desire.

To Return to the Preset Stitch Width (or clear the stitch width):

Press the Stitch Width button again (or press the Clear button).

The stitch width light and the indicator screen will go off.

• Stitch Length Button

This button sets the stitch length for both straight and zigzag stitches.

When you press the stitch length button, the stitch length light will go on and the indicator screen will show the pre-set stitch length:

"2.0" for straight stitching

"1.5" for zigzag stitching

NOTE: The range of stitch length depends on the stitch pattern you select.

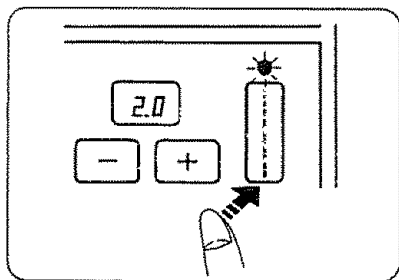

To Decrease the Stitch Length:

Press the "-" button.

The stitch length will decrease

— by 0.1 mm from "1.0" down to "0.0"

— by 0.5 mm from "4.5" down to "1.0"

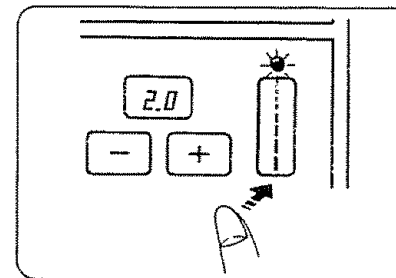
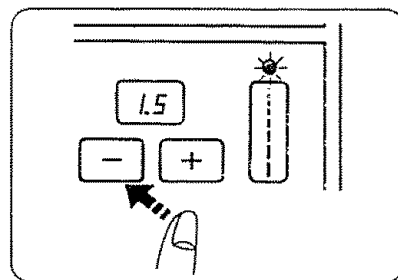

To Increase the Stitch Length:

Press the "+" button.

The stitch length will increase

— by 0.1 mm from "0.0" up to "1.0"

— by 0.5 mm from "1.0" up to "4.5"

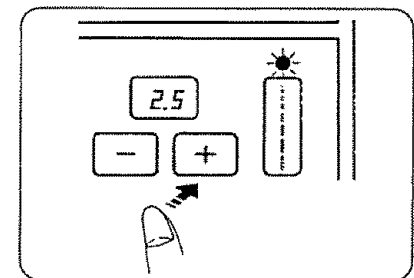

To Adjust the Stitch Length Quickly:

Hold Down the "+" or "-" button until you reach the length you desire.

To Return to the Preset Stitch Length:
(or clear the stitch length setting)

Press the Stitch Length button again (or press the Clear button). The stitch length light and the indicator screen will go off.

SECTION 3: LEARN TO USE THE CONTROLS

Reverse Stitch and Auto-Lock Buttons

Both of these buttons will secure seams.

- **Reverse Stitch Button (manual — no memory)**

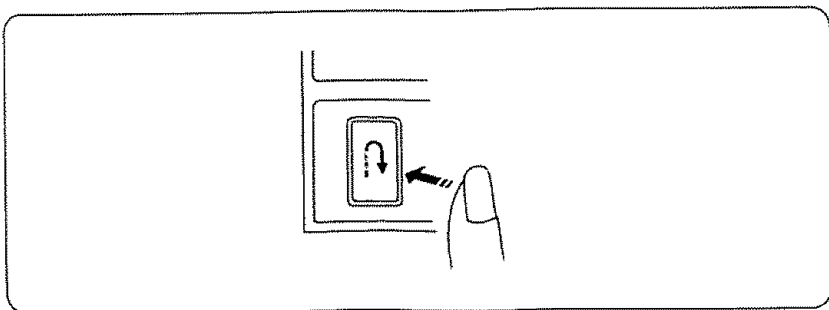

Use this button to;

- secure seams
- reinforce the seams and the top edges of pockets

Press and hold the reverse stitch button.

The machine will sew in reverse until you release the button.

- **Auto-Lock Button (automatic with memory)**

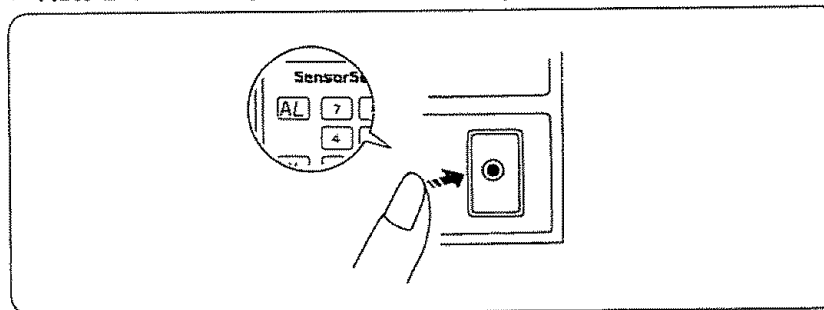

Use this button to;

- secure seams with an auto-lock stitch at the first and last stitch you sew.

To Use the Auto-Lock Stitch:

Press the Auto-Lock Button.

The pattern indicator screen will show "AL".

The machine will take a few stitches in place and stop automatically.

To Use the Auto-Lock Memory:

1. Press the Auto-Lock Button.
2. Press the Memory Button.
3. Press the Stitch Pattern Buttons you desire. (Be sure to press the Memory Button after each stitch pattern selection.)
See p. 82 for more details.
4. Press the Auto-Lock Button.
5. Press the Memory Button.

Turn a Square Corner

The Stitching skills covered in this section require some special skill from you. For all other stitches, your machine does most of the work. Even if you are skilled at these stitches, you will want to learn the features of this machine that may be new to you.

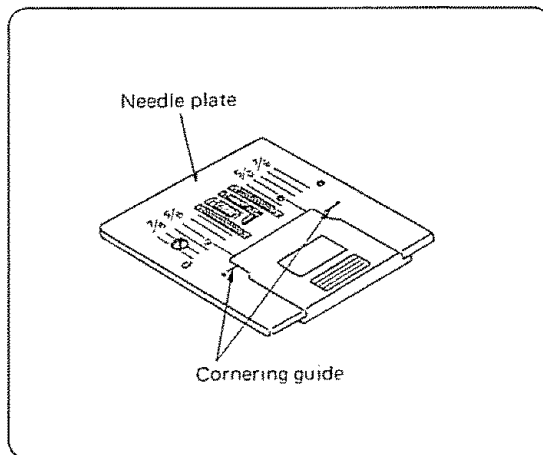
Use the Seam Guides

The seam guides on the needle plate are there to help you measure seam width. The lines are 1/8" apart, with the 5/8" and 7/8" lines marked.

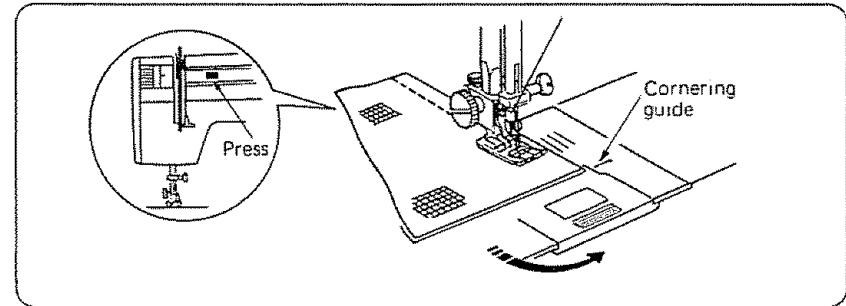

To turn a square corner 5/8" from the fabric edge:

1. Stop stitching and lower the needle by pressing the Up/Down Needle Position button when the fabric edge facing you lines up with the cornering guide, as shown.
2. Raise the presser foot and turn the fabric to line the edge with the 5/8" seam guide.
3. Lower the presser foot and begin stitching in the new direction.

SECTION 4 PRACTICE COMMON STITCHING SKILLS

Sew on Heavy Fabrics

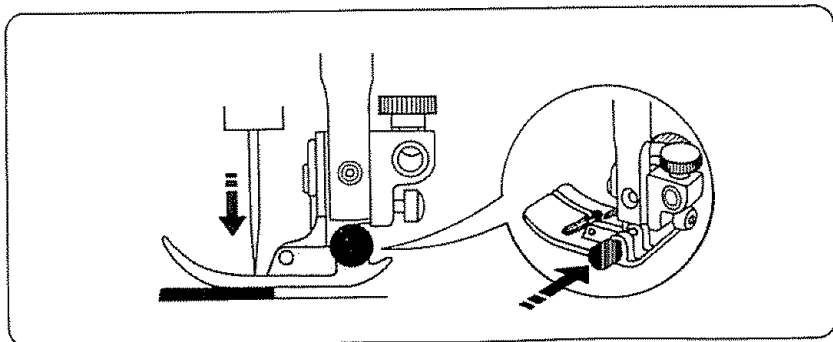

Use this skill when sewing from 3 to 12 layers of fabric, such as sewing over welt seams when hemming jeans.

1. Use Foot A (Zigzag foot) with the black spring button.

NOTE: This black button locks the foot so it does not give with the fabric.

2. Sew as usual.
3. When your needle reaches the point where the fabric layers increase, stop.
4. Lower the needle and raise the presser foot.
5. Press and hold the black button as you lower the presser foot.
6. Release the black button and continue sewing.

Use the Darning Plate

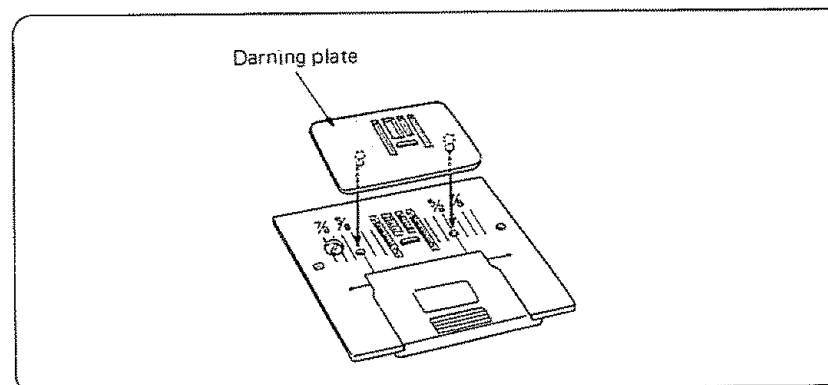

Sometimes when you sew, you want to control the fabric yourself. The Darning Plate covers the feed dogs so that they do not touch the fabric.

To Put on the Darning Plate:

NOTE: The rectangular holes in the Darning Plate match the holes in the needle plate. In the darning plate, these holes are slightly to the right of center.

1. Position the darning plate with the pins on the bottom.
2. Fit the darning plate pins into the needle plate holes at the 5/8" mark. The feed dogs will show through the darning plate holes.

Use the darning plate in the following ways:

- Basting (P. 37)
- Darning (P. 38)
- Button Sewing (P. 39)

Basting 14

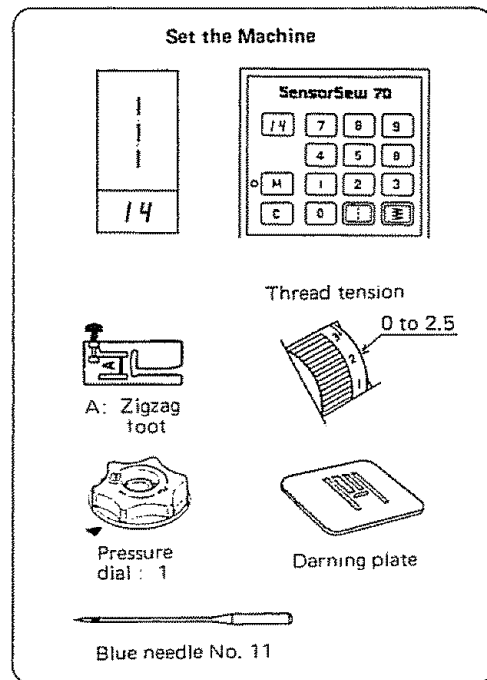

Use the darning plate for basting.
(See p. 36 for details.)

Use this stitch to:

- baste seams
- tailor tack
- tack quilt layers

CAUTION: Do not use this stitch if the needle will leave permanent marks in the fabric. A small needle will be less likely to leave permanent marks.

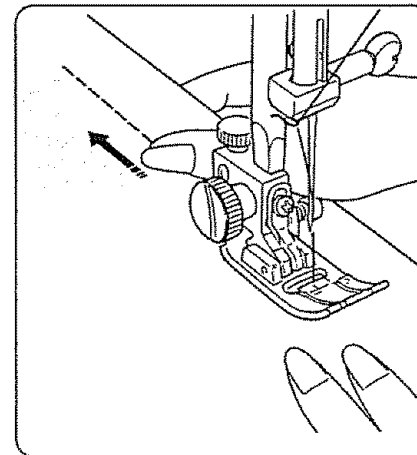

1. Press the foot control.
The machine will take one stitch and stop automatically.
2. Release the foot control.
3. Hold the fabric taut and slide it to the place where you want the next stitch.
4. Press the foot control.
5. Take out the darning plate when finished.

NOTE: Reset the tension and pressure dial for straight sewing.

SECTION 4. PRACTICE COMMON STITCHING SKILLS

Darning 10

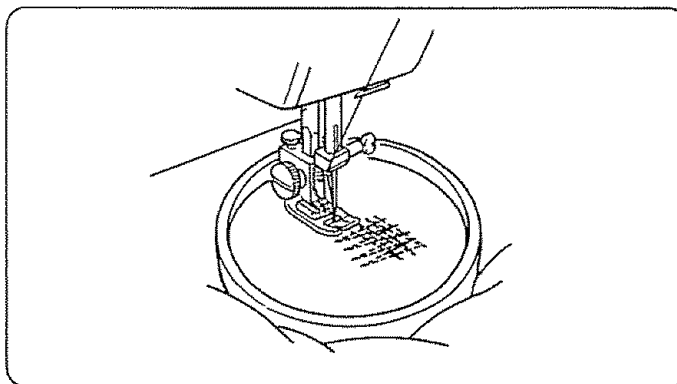
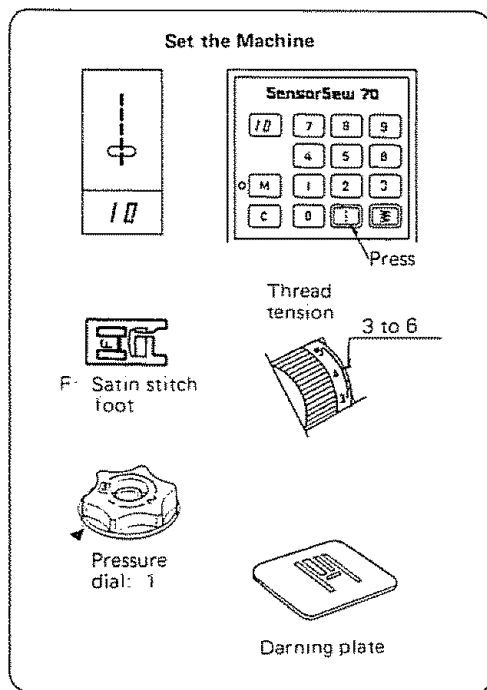

1. Put the darning plate on the needle plate (see p. 36).
2. Stretch the fabric with the hole in the center between embroidery hoops, as shown.
3. Lower the presser bar and sew at a slow speed.
4. Move the fabric back and forth slowly until you have covered the darning area.
5. Turn the fabric 1/4 turn and sew another layer of stitching over the first layer.

NOTE: If your fabric is thin or badly damaged, use a separate piece of fabric under the hole to reinforce it.

6. When you finish darning, return the pressure dial to 3 and remove the darning plate.

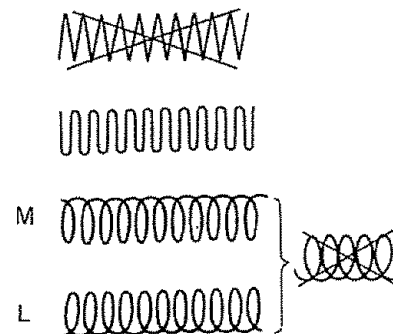

How to darn correctly

Make the turning points of each row blunt or the stitching will draw little holes at the ends. Beginners may prefer the L or M movement. Take care not to get circles.

The quick mastering of this work depends on regular guiding.

Therefore:

- Hold the hoop correctly.
- Always work from left to right (as when writing).
- Move work lengthways (not sideways) for selvedge and weftway.

Sew a Button

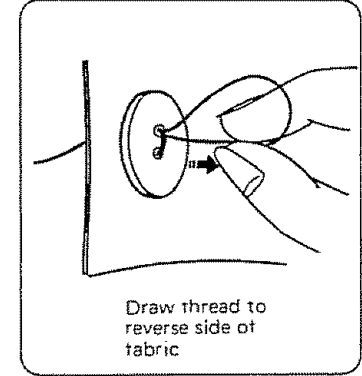
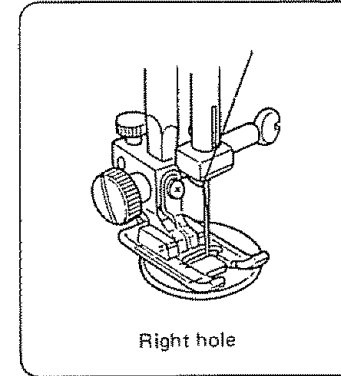
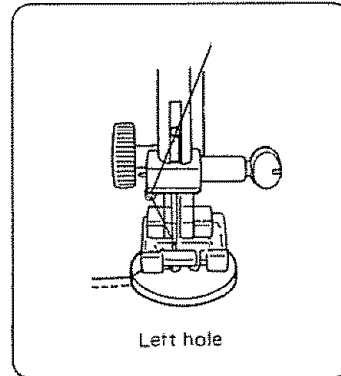
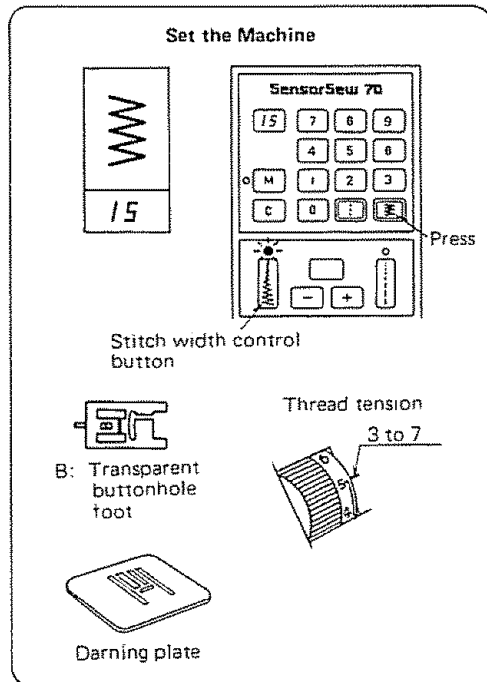

Use the darning plate for button sewing (see p. 36).

1. Match the button holes to the horizontal slot on the presser foot.
2. Lower the foot to hold the button in place.
3. Turn the hand wheel by hand until the needle point is just above the button.
4. Press the stitch width button (+ or -) so the needle will enter the left hole of the button.
5. Turn the hand wheel so the needle will enter the right hole of the button. Readjust the stitch width if necessary.
6. Stitch several times.
7. After you finish sewing, cut the thread but leave 3 to 4 inches of thread at the button.
8. Draw the thread to the reverse side of the fabric and knot the threads.

SECTION 4. PRACTICE COMMON STITCHING SKILLS

Put in a Zipper

It's as easy as A – B – C

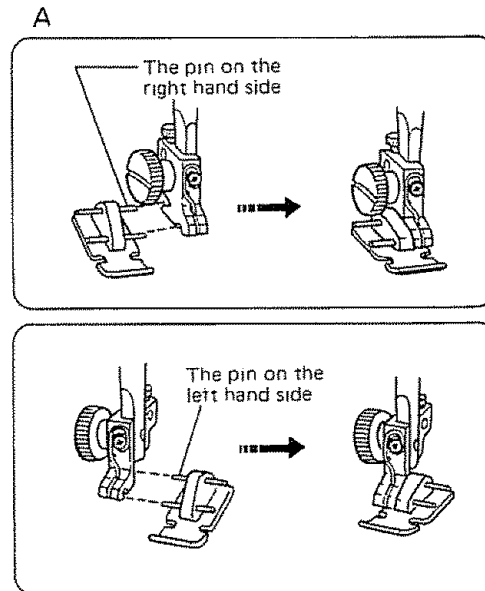
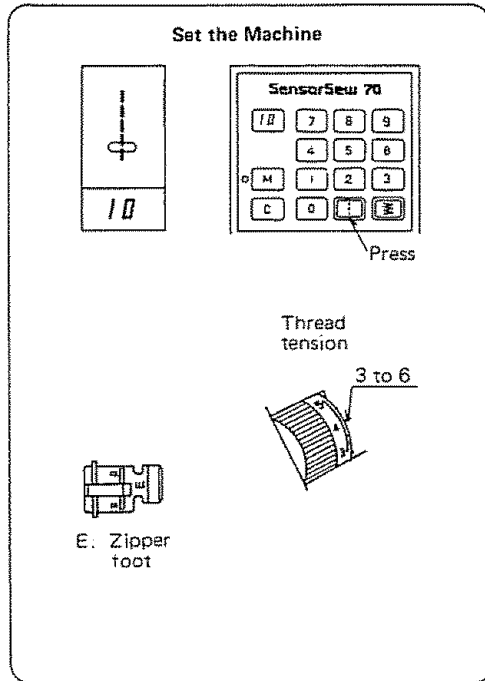

- A. Attach the zipper foot, as shown.
1. To sew on the right side of the zipper, attach the presser bar to the right pins on the zipper foot.
 2. To sew on the left side of the zipper, attach the presser bar to the left pins on the zipper foot.

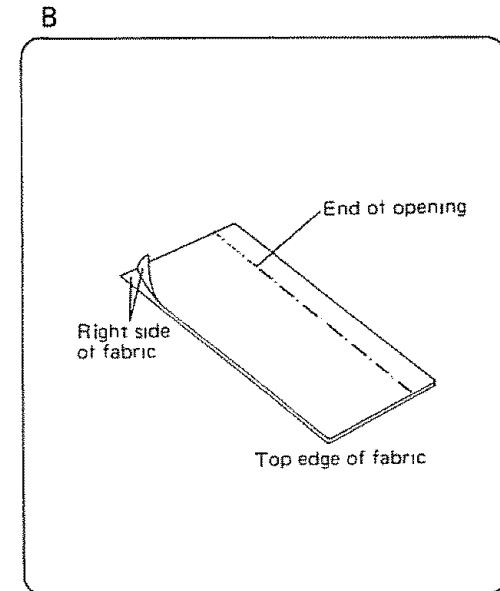

- B. Prepare your fabric.
1. Put the right sides of the fabric together and sew to the end of the zipper opening. Use the reverse to lock the stitches.
 2. Set the stitch length at "4.5" and sew the zipper opening.

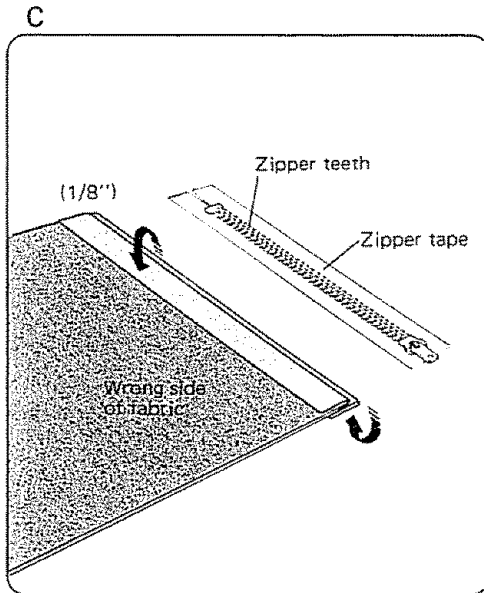

- C. Sew in the zipper.
1. Fold back the left seam allowance as shown.
 2. Turn under the right seam allowance to form a 1/8" fold.
 3. Place the zipper teeth next to the 1/8" fold and pin in place.

NOTE: Be sure the top of the zipper (the slider) is at the top of the garment.

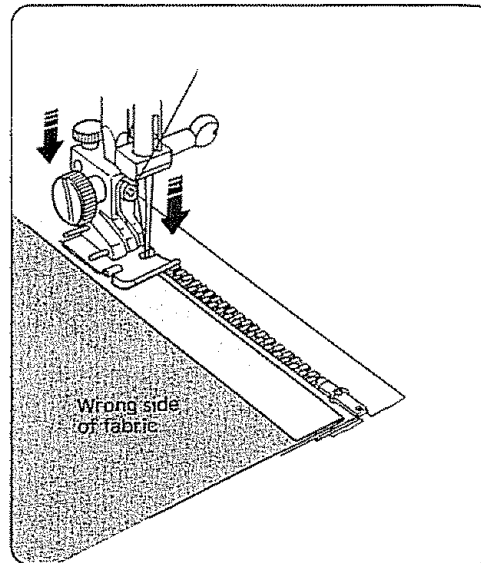

4. Attach the presser bar to the right pins on the zipper foot.
5. Lower the zipper foot on the right side at the bottom of the zipper so that the needle pierces the fold and the zipper tape.
6. Sew through the fold and the zipper tape to the point where the slider begins.
7. Lower the needle to hold the fabric and raise the presser foot.

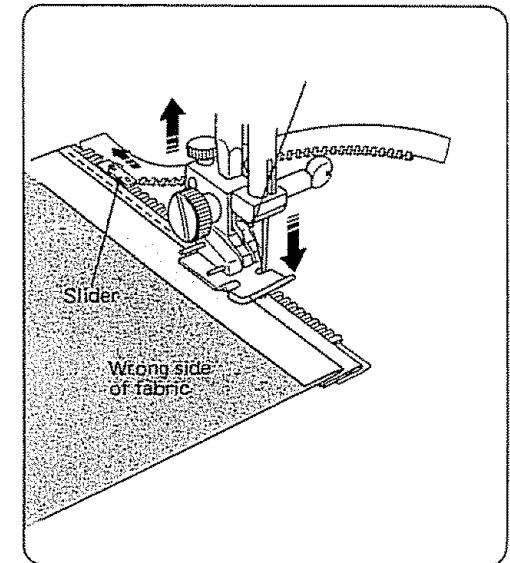

8. Open the zipper.
9. Lower the presser foot and stitch the rest of the seam.

SECTION 4 PRACTICE COMMON STITCHING SKILLS

Put in a Zipper (Continued)

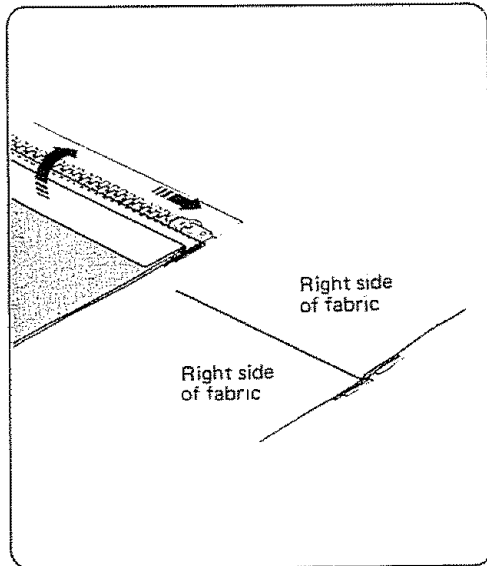

10. Close the zipper and turn the fabric right side up. Spread flat.

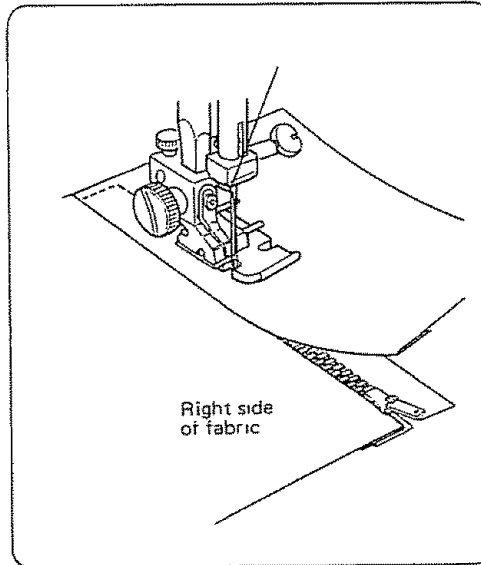

11. Remove the zipper foot and attach the presser bar to the left pins on the zipper foot.
12. Stitch across and below the bottom of the zipper.
13. Turn the corner and continue to guide the foot along the zipper teeth, as shown. Stitch through the fabric and the zipper tape.

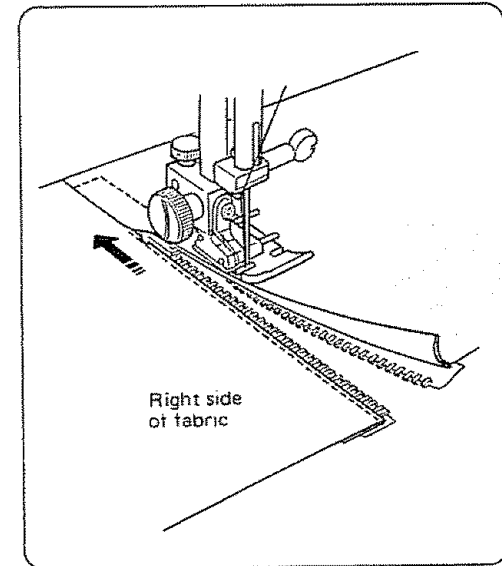

14. Stop about 2" from the top of the zipper.
15. Lower the needle into the fabric and raise the presser foot.
16. Remove the basting stitches and open the zipper.
17. Lower the foot and stitch the rest of the seam. Make sure the fold is even.

This section, discussing the many stitches available to you on this machine is organized by the stitch numbers on your Chart of Stitch Patterns. There are some variations and overlaps, but generally the stitches are here in numerical order.

However, you may know what you want to sew but may not be aware of the stitch to use to complete your sewing task. A Chart of Sewing Functions precedes the Chart of Stitch Patterns and the discussion of stitches, to aid you in locating quickly the stitch pattern and instructions you need.

NOTE: If a stitch pattern on this machine can be used for stitching stretch fabrics, you will find the word "stretch" in parentheses after the stitch pattern name. All stitch pattern on the Chart of Stitch Patterns (P. 45 to 49) will be labeled with an "S" in the name box.













SECTION 5. LEARN THE STITCHES

Chart of Sewing Functions

Now that you are familiar with your machine and ready to sew, what are you going to sew? The following chart tells you (in alphabetical order) what sewing functions this machine performs and directs you to the proper page for detailed instructions. In many cases, you also have your choice of stitches.













FUNCTION	STITCH PATTERN(S)	Ref. Page	FUNCTION	STITCH PATTERN(S)	Ref. Page
APPLIQUE	31	47, 74	GATHER	10	45, 55
BARTACK	15/16	46, 65, 67	HEMS	17/18/28/29	46, 47, 63, 64, 71
BASTE	10/14	37, 45	KNITS, STRETCH FABRICS	See all Stitches marked "S"	45~49, 56, 57, 58 63, 64, 71, 72, 73, 74 75, 76, 77, 80, 81
BATHING SUIT, SEW	18	46, 64	MEND	10/15/16	45, 46, 62
BLIND HEM	28, 29	47, 71	PINTUCKS	10	45, 53
BUTTON, SEW	15	39, 46	QUILT	10/32	45, 48, 54
BUTTONHOLE			REINFORCE SEAMS	11/16/33	45, 46, 48, 75~77
BARTACK	19~21		SHELL TUCKS	29	47, 72
ROUNDED	22~24	46, 65~67	SMOCK	32/42/43/48	48, 80
KEYHOLE	25~27		STRAIGHT SEAM	10	45, 50~55
CROSS STITCH	41	48, 79	STRETCH STITCH	12 and all stitches marked "S"	45~49, 56, 57, 58, 63, 64, 71, 72, 73, 74 75, 76, 77, 80, 81
CUT-OUT WORK	31	47, 74	TOPSTITCH	10	45, 51
DARN	10/16	38	SADDLE STITCH	13	45, 58
EDGE A GARMENT/PROJECT	17/18/29/ 30/31	46, 47, 63, 64 71, 72, 73, 74	OUTLINE STITCH	11	45, 56
DECORATE (WITH STITCHES)	29/32/33/ 34~39, 42~47	47, 48, 49, 72, 75 78, 80, 81, 82~84	TRIMS, SEW	10/15/16	45, 46, 59, 64
ELASTIC, APPLY	33/40	48, 75, 77	ZIPPER	10	40~42
EMBROIDER	10/15/41/44	45, 48, 60, 79, 81			
FAGOTING (create open work)	33/40	48, 76			
FINISH RAW EDGES	15/16/17 18/28/29	46, 47, 61, 62 63, 64, 71			

Stitch Pattern Chart











Stitch Pattern	No.	Foot	Other Attach.	Needle	Thread Tension	Pressure Dial	Uses	Refer to Page
STRAIGHT 	10	Straight (H)  Zigzag (A) 	Quilting guide Darning plate Zipper foot	Check Chart	2 ~ 6	3	Regular seams, pintucking, quilting, zippers, topstitching, darning, mending, basting, gathering, etc.	50 ~ 55
OUTLINE STRETCH 	11	Zigzag (A) 	—	Blue (11)	3 ~ 6	3	Use in place of straight stitch on knits, bias seams, tricot, chiffon for a flat, non-puckering seam.	56
STRAIGHT STRETCH 	12	Straight (H)  Zigzag (A) 	—	Check Chart	2 ~ 6	3	Use on knits and other stretch fabrics, good for topstitching.	57
SADDLE STITCH 	13	Zigzag (A)  Blind Stitch Hem Foot (G) 	—	14, 16, 18 or Check Chart	2 ~ 6	3	Topstitching suits, blazers, jumpers, denim outfits.	58
BASTING 	14	Zigzag (A) 	Darning plate	Blue (11)	0 ~ 2.5	1	Basting, tailor tacks, tack quilt layers.	37

SECTION 5 LEARN THE STITCHES

Stitch Pattern Chart (Continued)











Stitch Pattern	No.	Foot	Other Attach.	Needle	Thread Tension	Pressure Dial	Uses	Refer to Page
ZIGZAG (regular) 	15	Zigzag (A) 	—	Check Chart	2 ~ 5	3	Mend, darn, finish edges, apply trims, embroider, gather, buttons, satin stitch, monogram, decorative stitches	59 ~ 61
ZIGZAG (multiple) 	16	Zigzag (A) 	—	Check Chart	3 ~ 6	3	Use for sewing patches, repairing straight or corner tears, finishing seams on terry-cloth, sewing bar tacks for belt loops and drapery pleats (strong than zigzag).	62
OVEREDGE SEAM 	17	Overedge (C) 	—	Check Chart	3 ~ 7	3	Use for overcasting, for knits and woven fabrics needing extra strength, for narrow seams on knits or heavy weight woven fabrics.	63
KNIT STITCH 	18	Zigzag (A) 	—	Blue (11)	3 ~ 6	1	Use for swimwear and stretch velour.	64
BUTTONHOLE Bartack Rounded Keyhole	19/ 20/ 21. 22/ 23/ 24. 25/ 26/ 27.	Sliding Buttonhole (J)  Transparent Buttonhole (B) 	—	Check Chart	1 ~ 5	3	Buttonholes in three shapes; also corded buttonholes.    Bartack Rounded Keyhole	65 ~ 67

Stitch Pattern Chart (Continued)



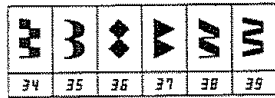
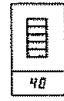

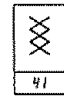

Stitch Pattern	No.	Foot	Other Attach.	Needle	Thread Tension	Pressure Dial	Uses	Refer to Page
BLIND HEM STITCH  S	28	Blind Stitch Hem Foot (G) 	—	Check Chart	1 ~ 4	3	Use for stretch fabrics, more elastic	71
BLIND HEM STITCH  S	29	Blind Stitch Hem Foot (G) 	—	Check Chart	1 ~ 4	3	Use for woven fabrics: blind hem and overcasting	71
SHELL STITCH  S	29	Transparent Buttonhole (B)  Satin (F) 	—	Check Chart	4 ~ 9	3	Finish hems, sleeve and neck openings Use on nylon tricot and other lingerie to overcast and seam. Do shell tucking on blouses and lingerie.	72
SCALLOP STITCH  S	30	Zigzag (A) 	—	Check Chart	3 ~ 6	3	Use for scalloped edges on collars, pockets or placemats. Create a delicate edge on thin fabrics. Decorate edges on hemlines or sleeves.	73
CUT-OUT WORK APPLIQUE  S	31	Satin (F) 	—	Check Chart	1 ~ 4	2	Use on cut-out work and applique for edging the designs, also on placemats, blankets, collars, cuffs and pockets.	74

SECTION 5. LEARN THE STITCHES

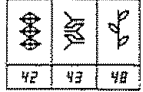
Stitch Pattern Chart (Continued)

Stitch Pattern	No.	Foot	Other Attach.	Needle	Thread Tension	Pressure Dial	Uses	Refer to Page
SMOCKING STITCH  32 S	32	Zigzag (A)  Satin (F) 	—	Check Chart	1 ~ 4	2	Use in smocking or as a decorative stitch.	80
FEATHER STITCH  33 S	33	Zigzag (A)  Satin (F) 	—	Check Chart	1 ~ 4	2	Hand-quilting stitch, used to reinforce stretch and woven fabrics, use on spandex undergarments and to decoratively hem elastic fabric. Use for patchwork quilting.	75
DECORATIVE GEOMETRICS 34/ 35/ 36/ 37/ 38/ 39.		Satin (F) 	—	Check Chart	1 ~ 4	3	Decorate garments with one row or several, one stitch or a combination. 	78
ELASTIC CASING FAGOTING  40 S	40	Satin (F) 	Use paper behind	Check Chart	3 ~ 7	3	Elastic Casing: replace bias tape casings in wrists and waists; tack down elastic. Fagoting: Join two folded edges for decorative open-work appearance.	76, 77
CROSS STITCHING  41	41	Satin (F) 	—	Check Chart	2 ~ 5	3	Use in embroidery, combine with letters and numbers for samplers.	79

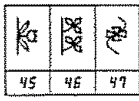
Stitch Pattern Chart (Continued)

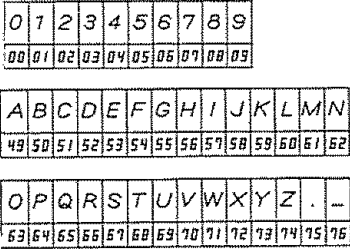
Stitch Pattern	No.	Foot	Other Attach.	Needle	Thread Tension	Pressure Dial	Uses	Refer to Page
SMOCKING STITCHES S	42/ 43/ 48 (32)	Satin (F) 	—	Check Chart	1 ~ 4	3	Smocking on children's clothes, blouses, curtains, etc. 	80
SAND STITCHING  S	44	Satin (F) 	—	Check Chart	1 ~ 4	1 or 2	Fill in designs already outlined with satin or other embroidery stitch.	81
STRETCH STITCH DECORATIVE	45/ 46/ 47.	Satin (F) 	—	Check Chart	2 ~ 5	3	Decorate with flower or leaf designs Use in combination (programmable) or singly. 	82 ~ 84
MONOGRAM Numbers, Letters, Period, Space	00~ 09 49~ 76.	Satin (F) 	—	Check Chart	2 ~ 5	3	Numbers and letters or sentences may be programmed in sequence for monogramming. 	85 ~ 86

SECTION 5: LEARN THE STITCHES

Straight Stitches 10 ~ 13

When you turn on your machine, it is automatically set to sew a straight stitch (pattern 10).

• Straight Stitch

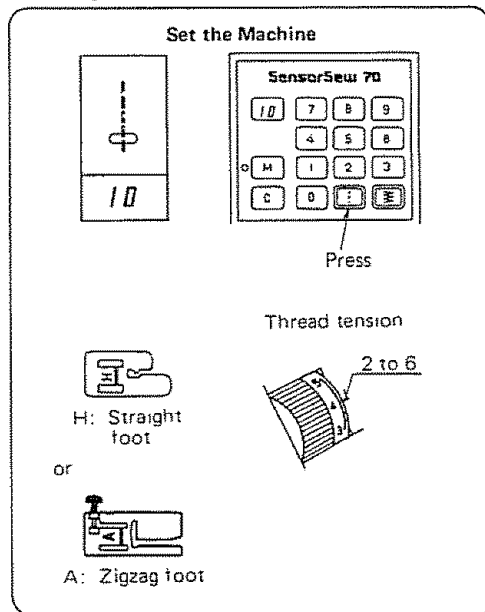

The Stitch and Its Uses

You can use your basic straight stitch in many ways besides just sewing a straight seam. Three common uses for the straight stitch are:

- Pintucking
- Quilting
- Topstitching

All are discussed in this section.

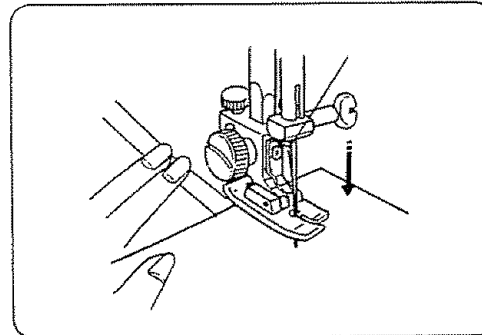

To sew a straight stitch:

1. Raise the presser foot.
2. Raise the needle to its highest position.
3. Place the edge of the fabric next to a stitching guide line on the needle plate (5/8" is most common).
4. Draw the threads towards the back and lower the presser foot.
5. Press the foot control.
6. Hold the fabric loosely and gently guide it along the guide line, so that it feeds naturally.

Do not force the fabric or try to pull it tight.

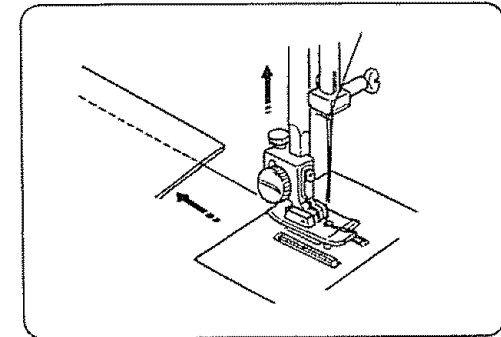

7. At the end of the seam, you may want to reverse to lock the stitch.
8. When you stop sewing, the needle will automatically rise to its highest position.
9. Raise the presser foot and remove the fabric.
10. Cut the threads.

• Topstitching

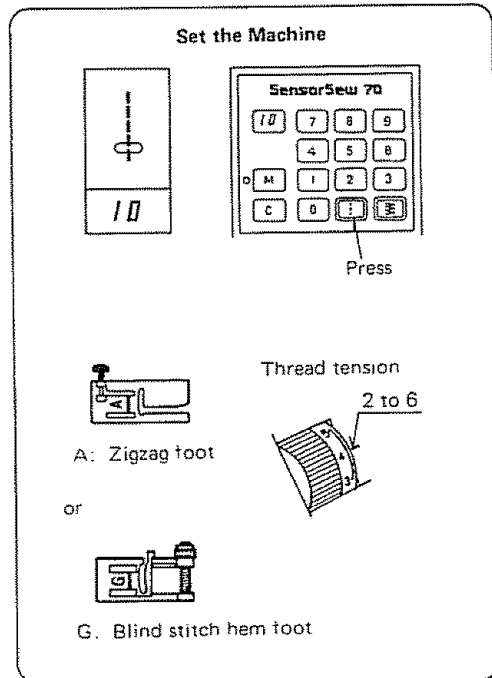

The Stitch and Its Uses

Topstitching emphasizes the lines of your garment and keeps seams and edges flat and crisp.

Accent suits or blouses with one or two rows of topstitching around the outer edges of cuffs, lapels or collars.

Use the Auto-Lock button to secure your topstitching and eliminate unsightly back-tacking.

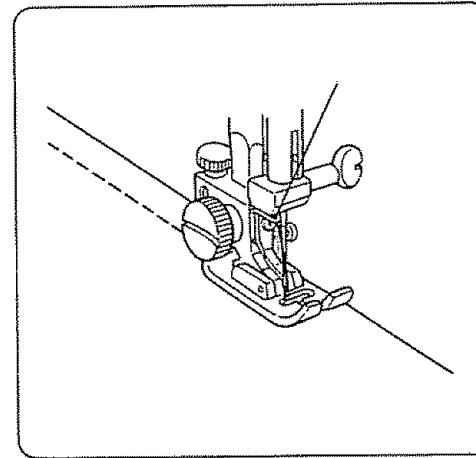

Here's How

1. Lower the presser foot.
2. Keep the edge of the fabric next to the right edge of Foot A.
3. Evenly guide the fabric along this edge to produce an even row of topstitching $\frac{3}{8}$ " from the edge.

NOTE: You can easily adjust your needles from left to right for topstitching without moving your fabric from under the presser foot.

SECTION 5. LEARN THE STITCHES

Straight Stitches 10 ~ 13 (Continued)

• Position Your Needle for Topstitching

The needle has three positions:
left, center and right.

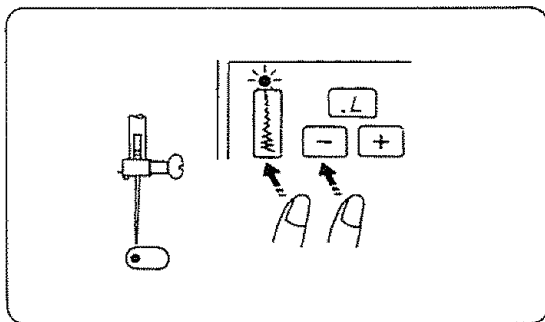

To position the needle to the left:

1. Press the stitch width control button.
2. Press the stitch length/width decrease button.
3. The stitch length/width indicator will show "L" or left needle position.

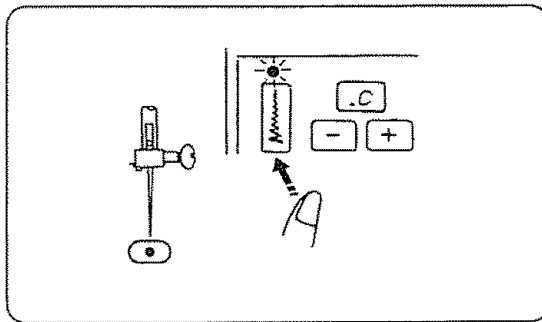

To position the needle at the center:

1. Press the stitch width control button.
2. The stitch length/width indicator shows "C" or center needle position.

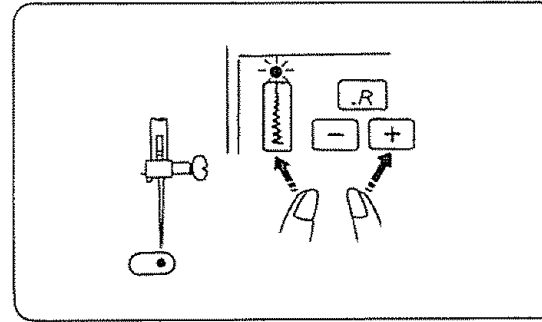

To position the needle to the right:

1. Press the stitch width control button.
2. Press the stitch length/width increase button.
3. The stitch indicator will show "R" or right needle position.

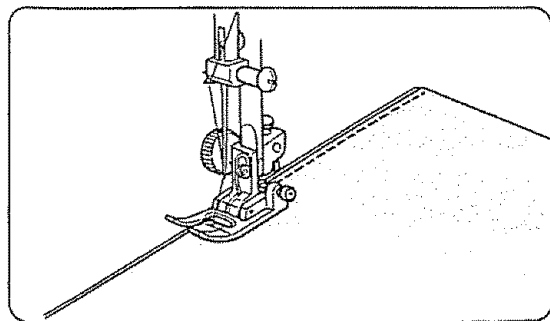

NOTE: Left or right needle position is recommended for stitching edge of the fabric.

Besides the normal straight stitch method of topstitching, this machine does other types of topstitching that are better for knits or produce a more elaborate decorative effect.

- Pintucking

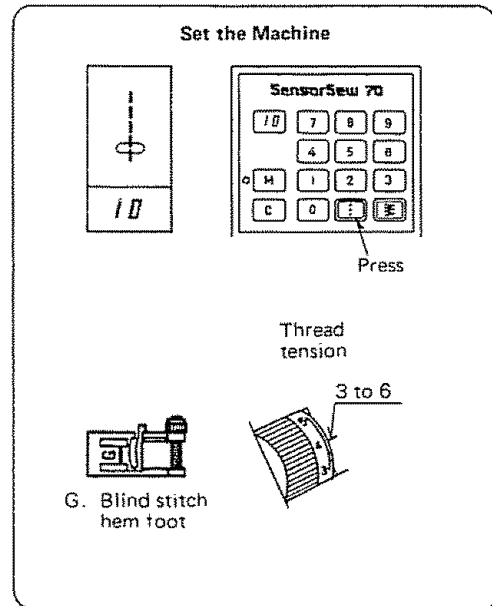

The Stitch and Its Uses

Pintucks are narrow tucks spaced close together to add design interest on such items as blouses and pillowcases. One pintuck can form a permanent front crease on knit pants.

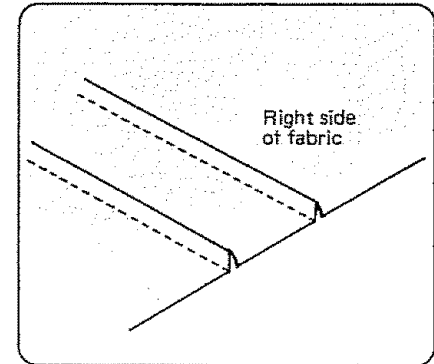
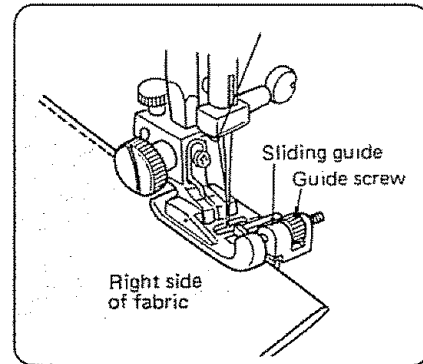

Here's How

1. Attach the blind stitch hem foot.
2. Place the folded fabric under the presser foot.
3. Position the needle 1/16" inside from the folded edge and lower the presser foot.
4. Adjust the sliding guide on the blind hem foot to the folded edge by turning the guide screw, as shown.
5. Feed the folded edge smoothly against the sliding guide.

NOTE: If the fabric tends to pucker, hold the material slightly taut while sewing. Also, try decreasing the upper tension slightly.

SECTION 5. LEARN THE STITCHES

Straight Stitches 10 ~ 13 (Continued)

• Quilting

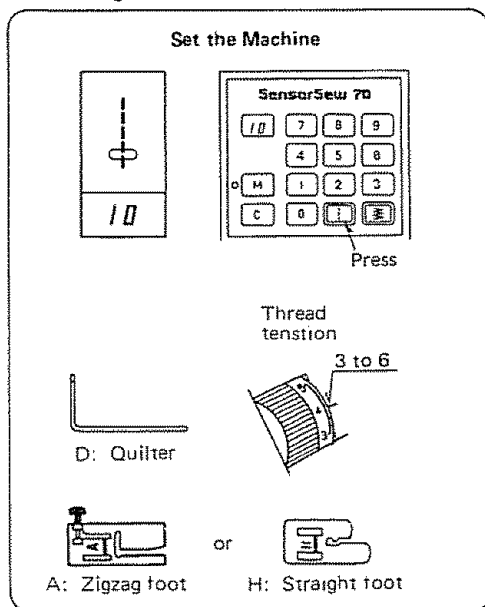

The Stitch and Its Uses

Quilting is stitching two layers of fabric together with batting in between to add dimension and warmth.

Traditionally, quilting has been used for bed covers, but now it is used everywhere.

You can use quilting on entire garments or parts of garments, such as yokes, pockets, cuffs and collars. It is also popular for table fashions. In addition to straight stitch quilting, you can quilt with decorative stitches or stitch pattern combinations.

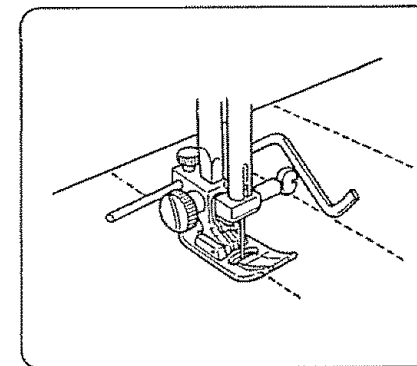
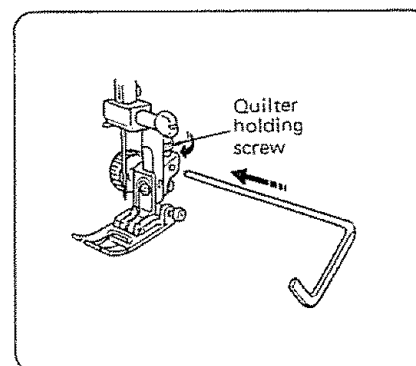

Here's How

To do quilting successfully, follow these simple steps:

1. Loosen the quilter screw on the back of the presser foot as shown.
2. Slide the quilting guide (D) into the opening under the screw to the width between lines of quilting stitches you desire.
3. Tighten the screw.
4. Sew the first row of stitching.
5. Sew other rows, guiding the quilting guide over the previous row of stitching.

NOTE: When you are quilting large areas, tack the layers together with the basting stitch. Then quilt from the center out.

Another quilting variation:

Instead of quilting with rows of straight stitches, you can bartack your quilt at regular intervals.

Set up the machine as if you were going to sew a button (see p. 39). Position your fabric and bartack.

- **Gathering**

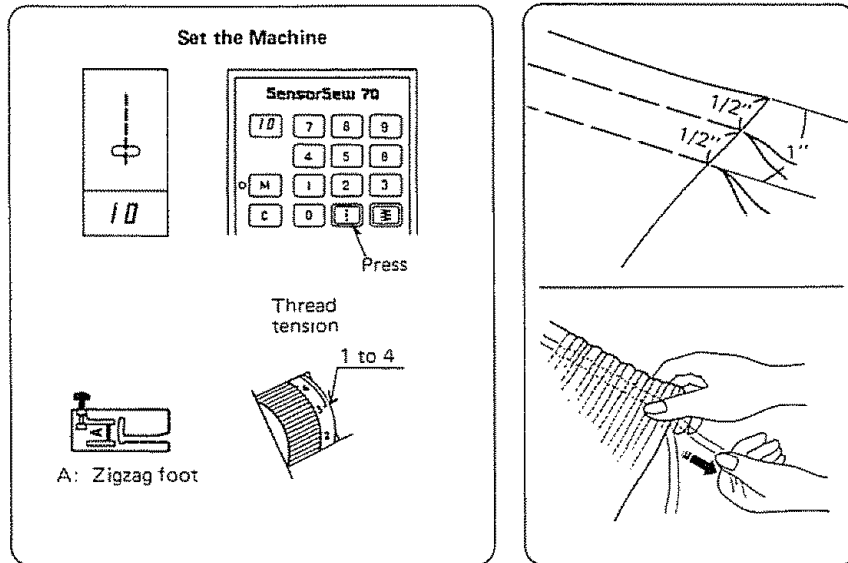

The Stitch and Its Uses

Use this stitch to gather trims, skirts, sleeves at the top, smocking or any time you want more fullness. You will need two rows of stitches.

Here's How (for medium weight fabrics and tight, firm gathers)

1. Set the stitch length to "4.0".
2. Loosen the needle thread tension to "2" or as desired.

NOTE: Steps 3 and 4 are for 5/8" seam allowances. For other widths, adjust your fabric accordingly.

3. Sew the first row of stitches with the right edge of Foot A on the edge of the fabric.
4. Sew the second row with the right edge of Foot A following the first row of stitches.
5. Using both hands, pull the bobbin threads from each end of the fabric until you have the gathers you want.
6. Knot the threads at each end and even out the gathers.

Here's How (for light weight fabrics, ruffles and flounces)

1. Set your stitch length at "4.5".
2. Secure your gathering rows at the beginning.
3. Stitch two rows, as in steps 3 and 4 for medium weight fabrics.
4. Do not lock the threads at the end of your stitching rows.
5. Pull the bobbin threads to produce the fullness you desire.
6. Knot the threads and even out the gathers.

SECTION 5. LEARN THE STITCHES

Outline Stretch **11**

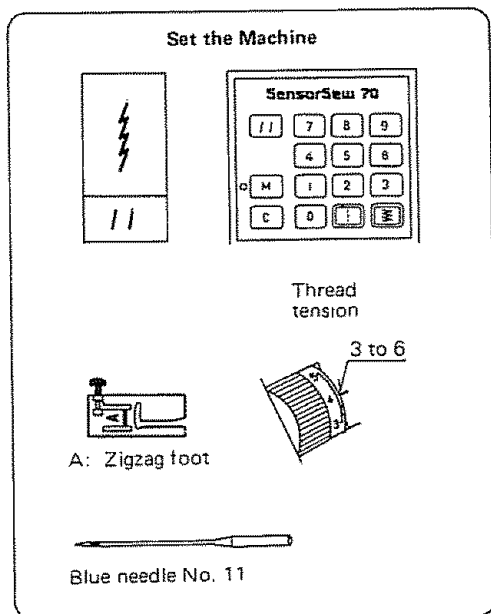

The Stitch and Its Uses

This stitch pattern, a variation of the straight stitch, is a narrow stretch stitch designed to eliminate puckering on knit fabrics and bias seams.

On tricot and filmy chiffons, it can be used to seam and overcast at the same time to produce a narrow, almost invisible seam or seam finish.

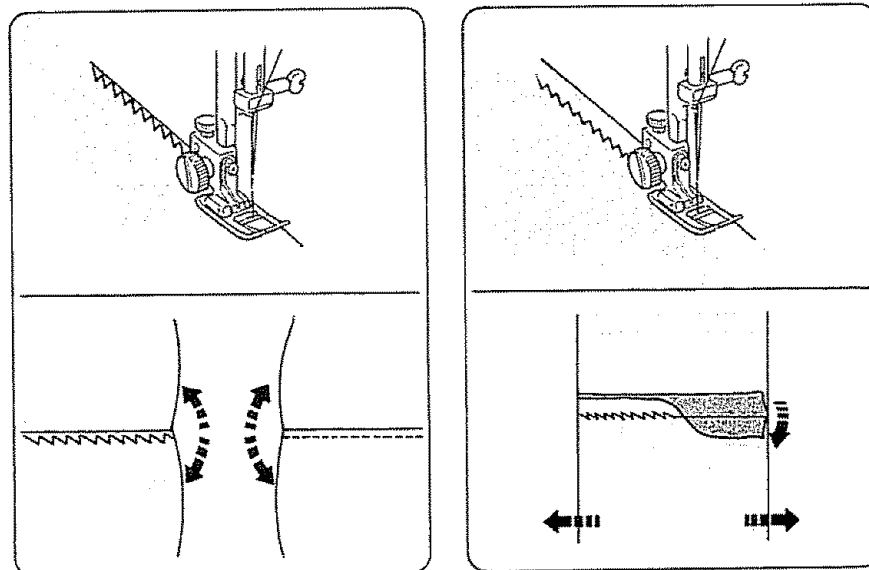

Here's How:

1. Place your fabric edge on the 6/8" seam line in order to produce a 5/8" seam.
2. Sew as you would a straight stitch.

Helpful Hints (for lightweight fabrics)

1. Set the pressure dial at "1" or "2".
2. To seam and overcast tricot:
 - a. Set the stitch width at "3"
 - b. Sew with the right hand stitch falling off the fabric edge.

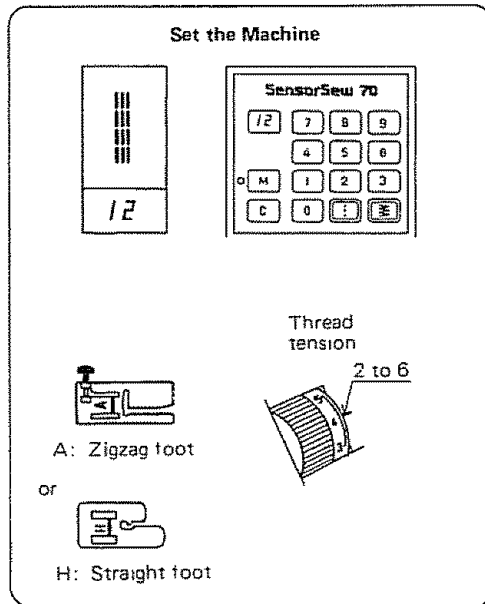
Straight Stretch **12**The Stitch and Its Uses

This stitch is the stretch variation of the straight stitch, especially developed for knits and stretch fabrics.

This stitch can also be used for topstitching.

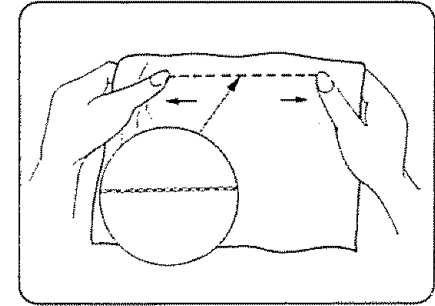
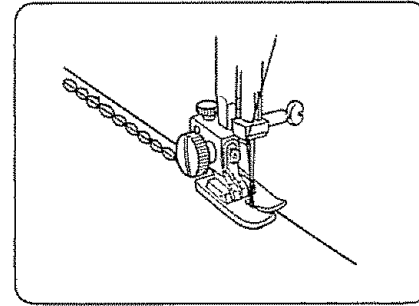
**A NOTE ON STRETCH STITCHING**

Stretch stitching was developed to be used on stretch fabrics and knits. It can be used on other fabrics as well. It works well on curved seams and on any garments that will receive a great deal of strain (ie. children's clothes).

The stretch stitch does not actually stretch as it is being sewn, but is stitched in a forward and back motion (sometimes called a "reverse-action" stitch), so that it will give when the fabric stretches instead of breaking.

SECTION 5. LEARN THE STITCHES

Saddle Stitch 13

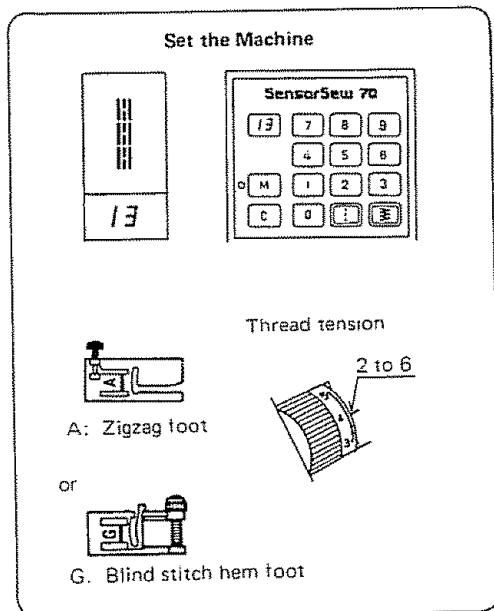

The Stitch and Its Uses

The saddle stitch is formed with one stitch forward, two stitches backward, and a fourth stitch forward.

You can achieve a lovely hand-worked look when topstitching suits, blazers, jumpers, and denim outfits with the saddle stitch.

NOTE: Adjust the needle position for the effect you want.

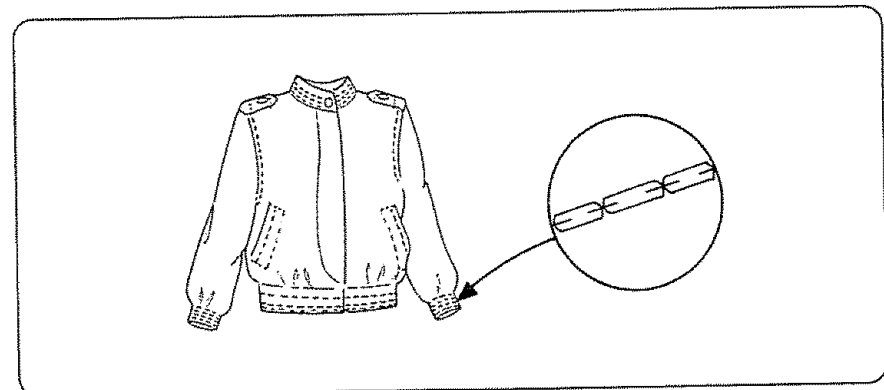

Here's How

1. Sew as you would for topstitching.
2. To turn corners:
 - a. Lower the needle into the fabric on the fourth stitch.
 - b. Raise the presser foot and turn the fabric.
 - c. Lower the presser foot and continue to sew.

Helpful Hint

The Blind stitch hem foot is good to use when topstitching near the edge of the garment. Just set the edge guide with the guide screw.

Zigzag Stitches 15 ~ 18

• Basic Zigzag 15

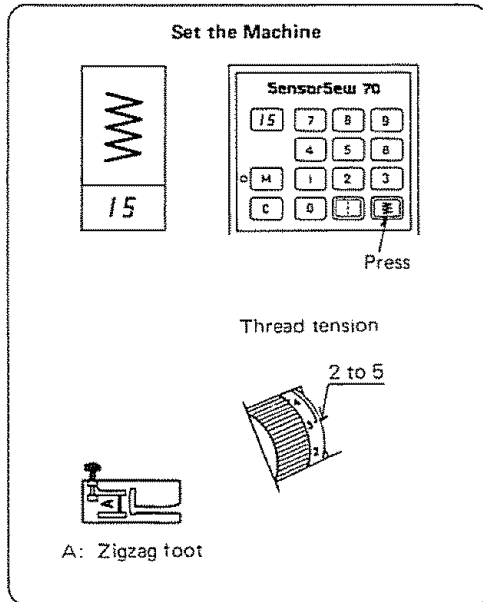
The Stitch and Its Uses

The zigzag stitch is one of the most common and most versatile stitches on your machine. It can be a utility stitch for sewing buttons, buttonholes, hemming, overcasting, mending and darning. It can also be used to decorate with trims, appliques and cut-out work or as a decorative stitch.

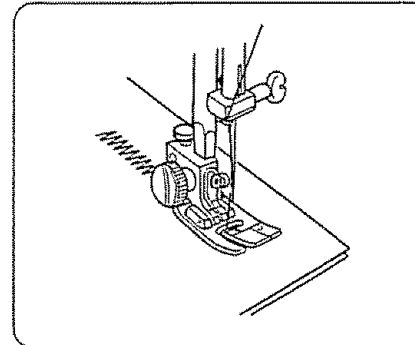
Here's How

The many ways to sew a zigzag stitch are as varied as the stitch patterns on this machine or as the width and length settings allow. Consult the specific variations for detailed directions.

The zigzag stitch as a utility stitch has several variations, discussed in this section:

- Satin Stitch 15
- Overcasting Stitch 15
- Multiple Zigzag 16
- Overedge Seam 17
- Knit Stitch 18

SECTION 5: LEARN THE STITCHES

Zigzag Stitches 15 ~ 18 (Continued)

• Satin Stitch 15

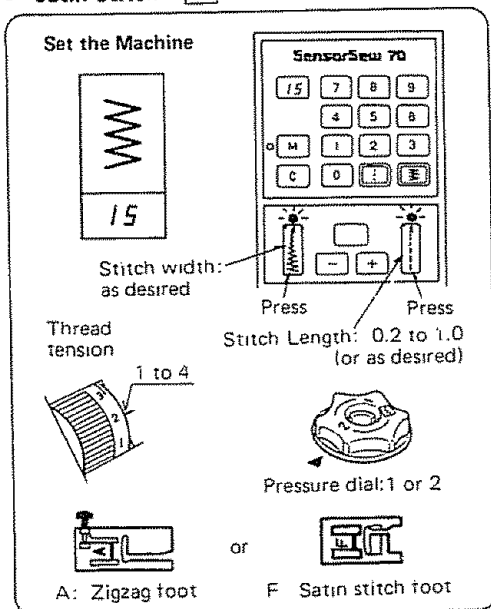

The Stitch and Its Uses

The Satin stitch is a versatile and often used decorative stitch, but it can also be used to overcast a raw edge (for example, blankets, linens, tablecloths and napkins).

The Satin stitch is especially attractive in applique and is the basis for the geometric stitches 34 to 39 on this machine.

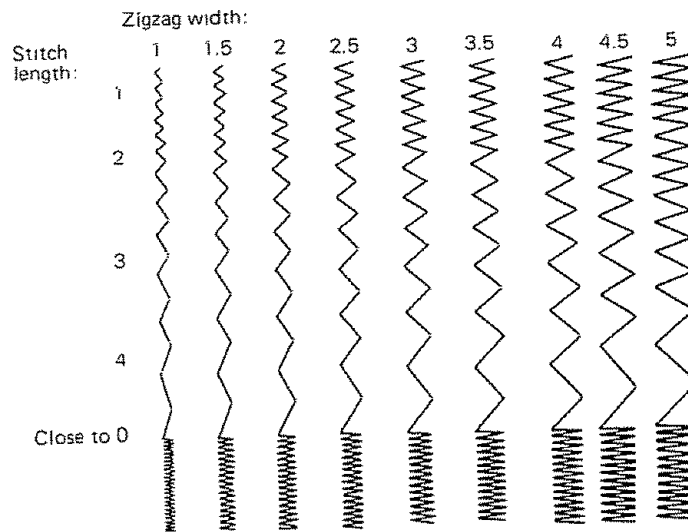

Here's How

Once your machine is set up to stitch, you may want to experiment on a fragment of the fabric you are planning to use. Too tight a satin stitch may pucker some light weight fabrics.

Otherwise, stitch as usual.

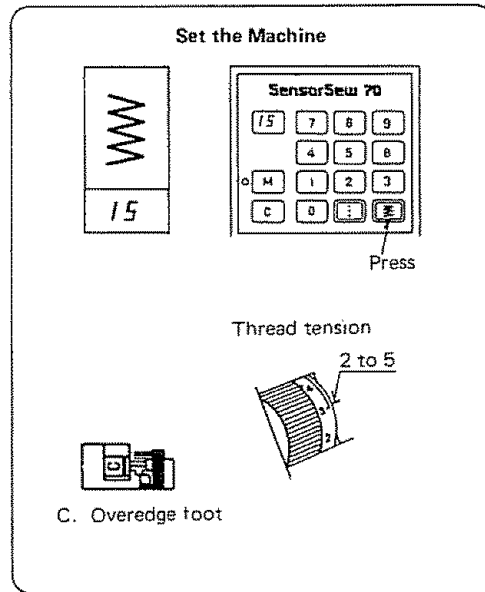
• Overcasting Stitch **15**The Stitch and Its Uses

This zigzag variation is very useful in garment construction and in finishing raw edges of any sewing project.

Here's How

1. The black ridge and brush and the guide wires on the overedge foot keep the edge neat and the fabric straight.
2. Place your fabric so that the double guide wires come to the edge.

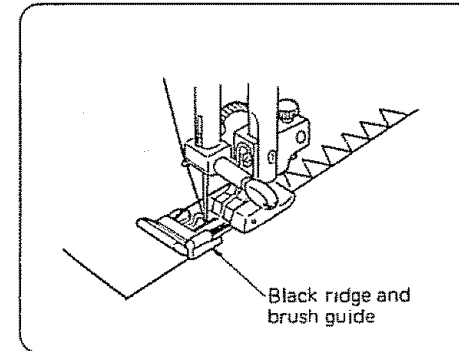

NOTE: These wires keep light weight fabric from rolling into a ridge and hold medium weight fabric flat.

The machine will stitch over these wires. The black ridge and brush will keep the loose threads in so that the needle can stitch over them.

3. As you sew, be sure your fabric edge pushes against the black ridge and brush guide.
4. When you stop sewing, remove the fabric by drawing it to the back and out. The fabric will catch on the wire guides if you pull it toward you.

Helpful Hints

Start overcasting about 1/8" inside the raw corner of your seam. If you start right at the edge, the fabric will bunch up and the stitches will become tangled.

For overcasting folded fabric:

You can also fold the raw edge of the seam and overcast.

1. Start the fold by sliding it under the needle and lowering the needle.

NOTE: Be sure your needle is in the left position.

2. Lower the presser foot so that both guide wires are on the fabric.
3. Fold the fabric to the left 1/8" as you feed it into the machine and stitch.

SECTION 5. LEARN THE STITCHES

Zigzag Stitches 15 ~ 18 (Continued)

• Multiple Zigzag 16

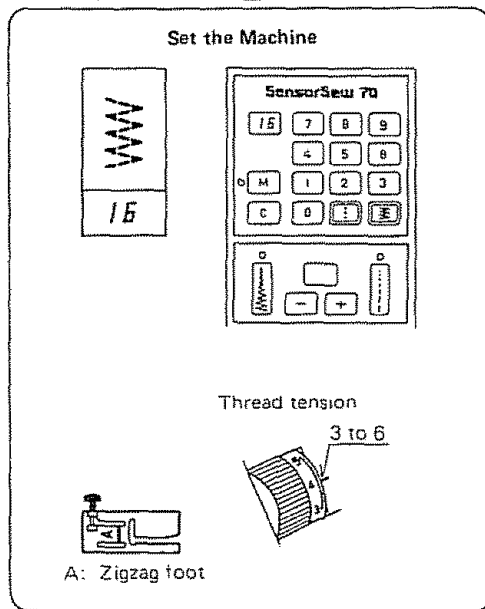

The Stitch and Its Uses

The multiple zigzag is a combination zigzag and straight stitch. You may use the multiple zigzag everywhere you would use the basic zigzag stitch. It has more strength, elasticity, and is flatter than a regular zigzag.

The multiple zigzag stitch is especially useful for:

- sewing patches smoothly and securely.
- repairing straight tears.
- finishing seams on terrycloth.
- sewing bar tacks for belt loops and drapery pleats.

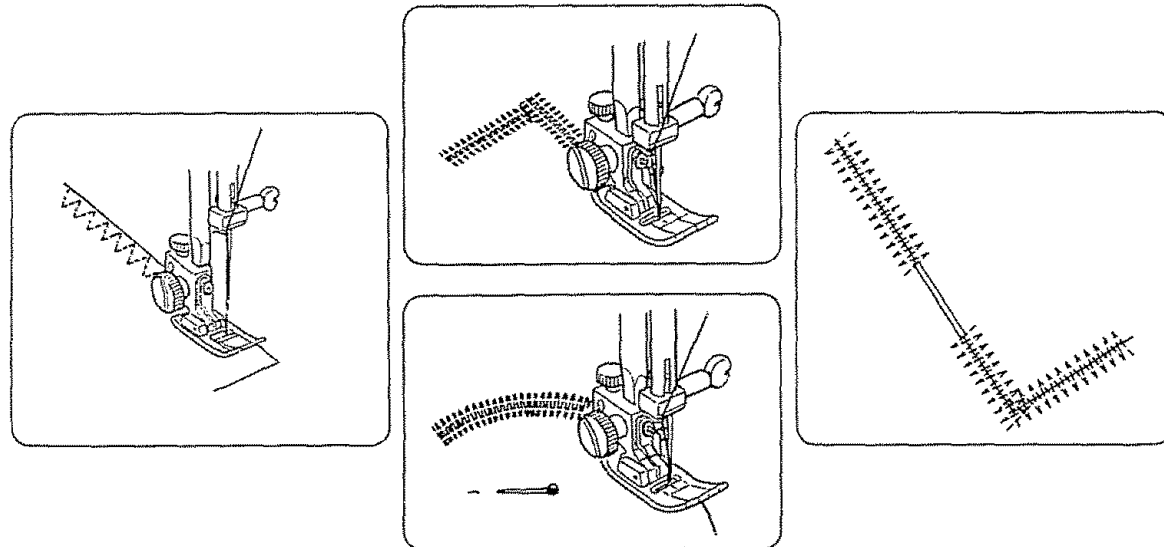

Here's How to Repair a Tear:

Straight — position the tear under the needle so that the stitching will catch both sides.

Cornered — stitch from each end to the center. Use a piece of fabric under the tear to reinforce your mending.

• Overedge Seam 17

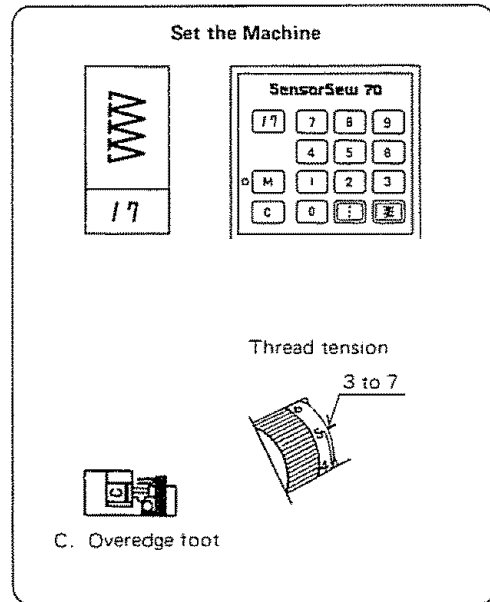
The Stitch and Its Uses

This stitch pattern combines the straight and the zigzag stitches, using the overedge foot, to stitch and overcast seams in one step. It also has a reverse cycle to provide elasticity for knits and extra strength for woven fabrics.

Use this stitch when you want a narrow seam that you do not need to press open flat. It is ideal for 1/4" seams on knits (when attaching ribbing) or on medium to heavyweight woven fabrics where you want a narrow seam.

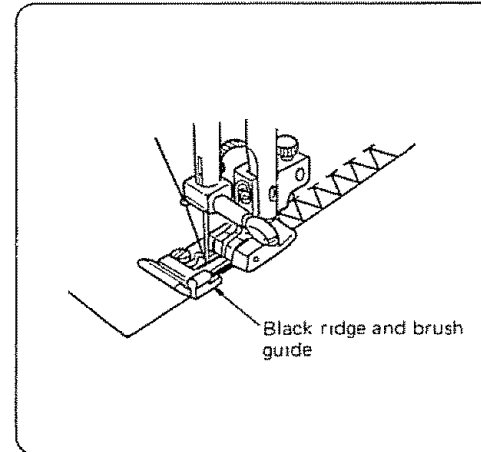
Here's How

1. Place your fabric so that the raw edges fit under the wire guides and touch the black ridge and brush guide.
2. Gently guide the fabric so that the raw edges always touch the black ridge and brush guide.

NOTE: When sewing over several thicknesses (under arms, in crotch, etc.) raise the presser foot slightly to ease the presser foot over the hump and keep stitches from bunching.

3. When you stop sewing, remove the fabric by drawing it to the back and out. The fabric or stitching will catch on the wire guides if you pull it toward you.

SECTION 5. LEARN THE STITCHES

Zigzag Stitches 15 ~ 18 (Continued)

• Knit Stitch 18

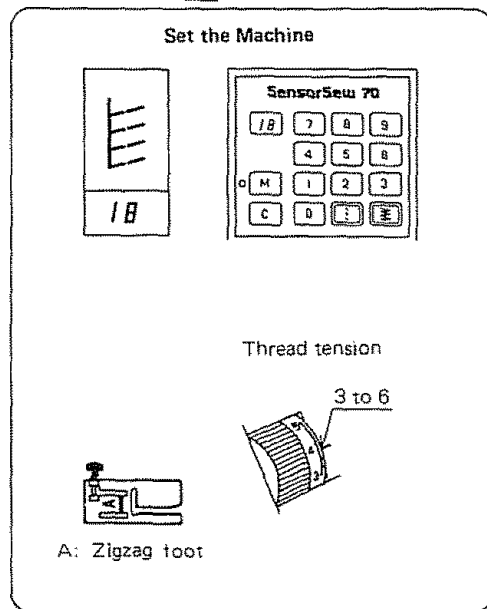

Set the Pressure Dial to "1", so that the knit will retain its shape as you are sewing.

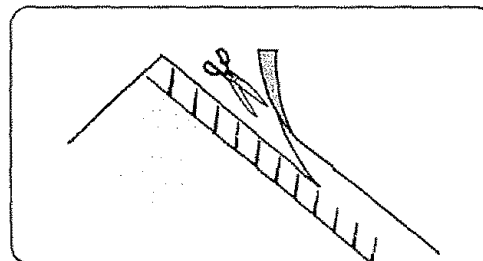
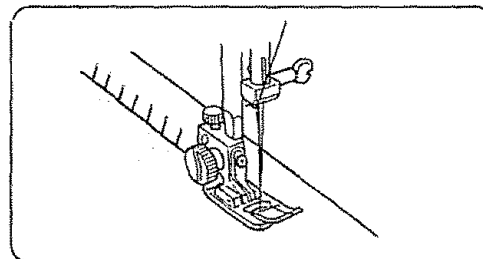

The Stitch and Its Uses

This knit stitch is ideal for sewing swimwear and stretch velour, because it provides the greatest amount of elasticity and strength.

Here's How

1. Place your fabric to allow a 5/8" seam.
2. Trim the seam allowance after sewing.

NOTE: Be careful not to cut the stitches.

Buttonholes 19 ~ 27

Set the Machine

Bartack

Press

Thread tension

J: Sliding buttonhole foot

or

B: Transparent buttonhole foot

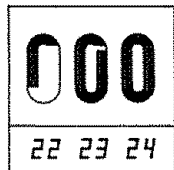

Rounded

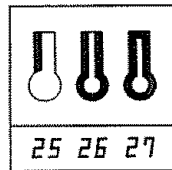

Keyhole

The Kenmore Sensor Sew 70 can make three types of buttonholes:

- the Bartack (19 ~ 21)
- the Rounded (22 ~ 24)
- the Keyhole (25 ~ 27)

Use either the Transparent Buttonhole Foot (B) or the Sliding Buttonhole Foot (J) to sew buttonholes.

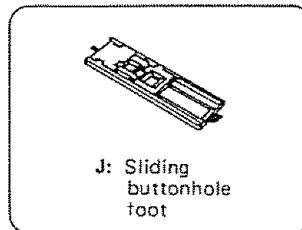

Foot (J) has marks you can use to decide on the length of your buttonhole. It also helps you know when the two sides are even. It has rubber grippers on the bottom to hold the fabric in place under the foot.

It is the preferred buttonhole foot.

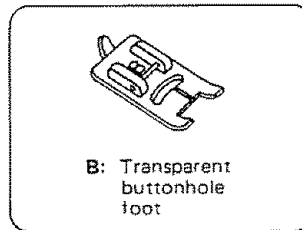

Foot (B) has a ridge down the bottom center of the foot to keep the stitched buttonhole sides evenly spaced. Use this buttonhole foot for tight spaces or buttonholes too large for the J foot.

IMPORTANT

For Perfect Matching Buttonholes

Here are some helpful tips.

(For details, follow the steps and notes on pages 66 and 67, carefully.)

1. Make sure you have a flat sewing surface.
 - * Use the extension table.
 - * Put cabinet-mounted machines in the flat-bed position.
 - * For table-top machines, support the fabric by hand.
2. Use the B Foot for sewing next to a thick seam.
3. Make sure the fabric around the needle and foot is slack.
 - * Do Not push or pull the fabric.
 - * Do bunch the fabric slightly all around the needle and foot to create slack.
4. Sew several practice buttonholes, duplicating exactly:
 - * the fabric
 - * the seam conditions
 - * the buttonhole position on the garment

SECTION 5. LEARN THE STITCHES

Buttonholes 19 ~ 27 (Continued)

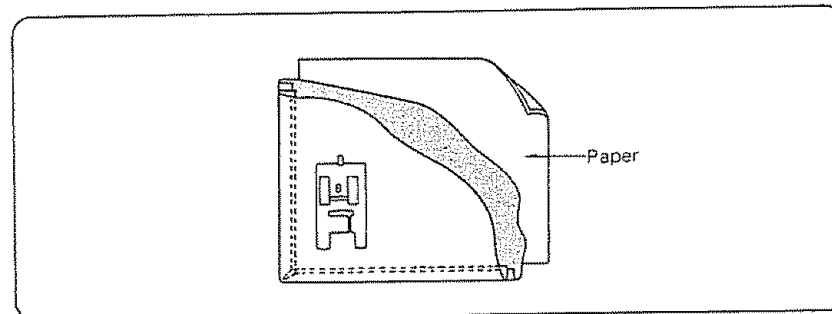
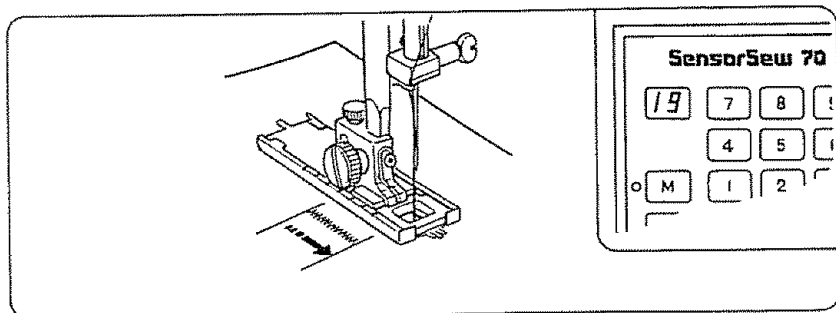

Here's How

NOTE: Before you sew buttonholes on the actual garment, make several practice buttonholes. Be sure to duplicate exactly:

- the fabric
- the seam conditions (folds, interfacing, topstitching, etc.)
- the buttonhole position on the garment

For Keyhole Buttonholes: Be sure the hole portion of the keyhole faces the edge of the garment.

1. Be sure your sewing surface is flat to prevent the fabric pulling against the fabric feed.

NOTE: Fabric pulled tight by its own weight (falling over the edges of the sewing surface) will be too tight and distort the automatic fabric feed. The buttonhole length and shape may change slightly from one buttonhole to another.

- a. Attach the extension table.
- b. If your machine is mounted in a cabinet, be sure the machine is in the flat-bed position.
- c. If your machine is on a table, be sure to support the fabric around the edges of the sewing machine surface.

2. Place the button on the fabric sample and mark the top and bottom to determine the buttonhole length.

NOTE: If the fabric is thick near the seam and your buttonholes, the length and shape of your buttonholes may vary. Try one or more of the following adjustments in order:

- a. Change to the B Foot.
- b. Start your buttonhole so that you sew towards the edge of the fabric, instead of away from it.
- c. Put standard writing paper (see illustration) (not tissue paper) under the buttonhole area next to the feed dogs, as you sew the buttonhole (for woven and stretch fabrics).
- d. Sew each buttonhole individually.
Do not use the Memory function.

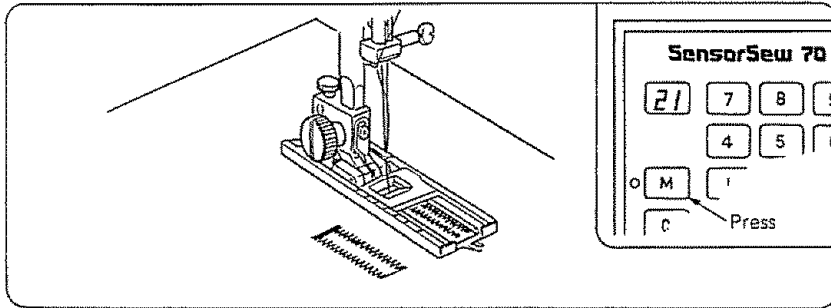

3. Press the first pattern selection button (**19** for bartack, **22** for rounded or **25** for keyhole).
4. Lower the needle to the top mark.

NOTE: To assure more uniform length and shape of your buttonholes, keep the fabric bunched slightly all around the needle and foot (see illustration) as you sew the buttonhole, so that the fabric does not pull tight in any direction.

For Bartack or Rounded Buttonholes, continue with Steps 5 and 6. For Keyhole Buttonholes, go to Step 7.

5. Sew down the left side and stop at the bottom mark at the end of the buttonhole.
6. Press the Memory Button **M**. The pattern indicator screen will show:
 - 20** — Bartack
 - 23** — Rounded, Go to Step 8.
7. Do not sew down to the bottom of the buttonhole but stop about 1/8" from the mark (**NOTE:** The red marks on the sliding buttonhole foot are helpful here) and press **M**.
The pattern indicator will show **26**.
See the Chart of Stitch Patterns for the stitching areas of **25** and **26**. Go to Step 8.
8. Sew up the right side until you come to the top mark. Stop.

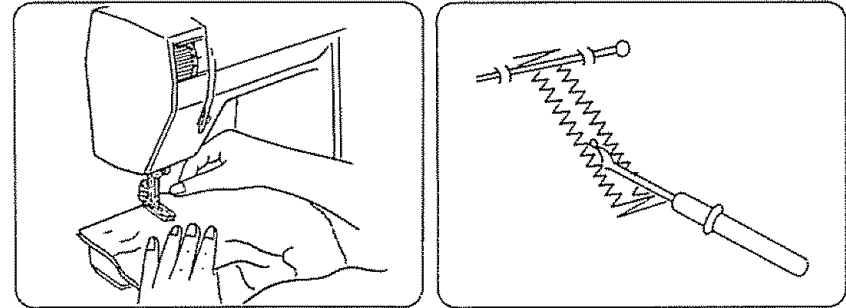

9. Press the Memory Button **M**.
The pattern indicator will show:

- 21** — Bartack
- 24** — Rounded
- 27** — Keyhole

The machine will bartack or auto-lock the end of the buttonhole and stop.

IMPORTANT: The machine stitches the last stitches slowly. Hold down the foot control until the machine has completed its stitches and has stopped.

Practice until you achieve the results you desire:

- size
- appearance
- stitch density (see P. 68)

10. Remove the fabric and place a pin in front of the bartack at the end of the buttonhole to prevent accidental cutting of the bartacks.
11. Cut the opening with the buttonhole opener in your accessory box.

NOTE: For keyhole buttonholes, pierce the hole first with the long point on the buttonhole opener. Then cut the rest of the buttonhole. Carefully remove the fabric from the keyhole with embroidery scissors.

Memory Function

The machine has now memorized this buttonhole. It will sew a complete buttonhole identical to the first one each time you press the foot control.

SECTION 5. LEARN THE STITCHES

Buttonholes 19 ~ 27 (Continued)

- Adjust the Stitch Density

You can adjust the stitch density of the entire buttonhole or of only one side.

The stitch length button controls the stitch density. It is pre-set at "0.4".

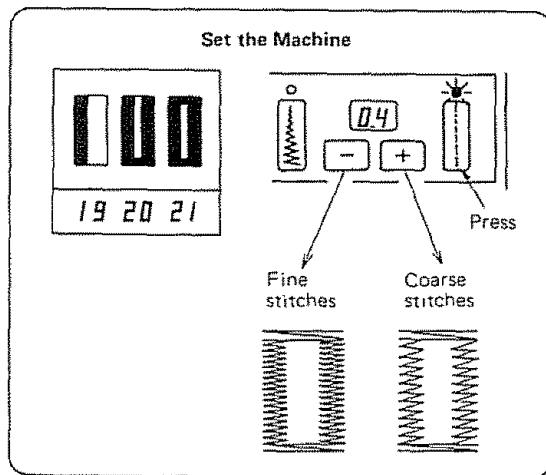

Stitch Density in Entire Buttonhole:

Press "+" or "-" to adjust the stitch density of the entire buttonhole.

Stitch Density on One Side:

The stitches on each side of the buttonhole should be the same stitch density. To adjust, use the feed balance dial below the Hand Wheel.

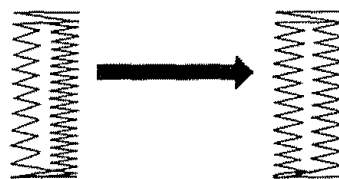
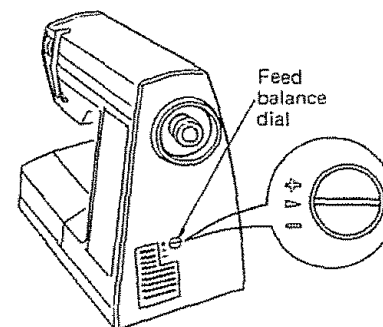

A

For Condition A:

Left Side Stitches too Far Apart
(see above)

Turn the feed balance dial slightly toward "-". Use the large screw driver in your accessory box.

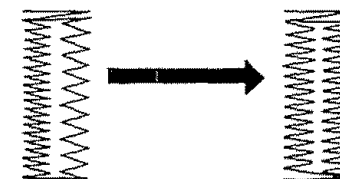

B

For Condition B:

Right Side Stitches too Far Apart
(see above)

Turn the feed balance dial slightly toward "+".

After adjusting the feed balance dial, sew another test buttonhole to be sure your adjustment is correct.

NOTE: Remember to turn the feed balance dial to the standard mark (▶) when you have completed your buttonholes.

Corded Buttonholes 19 ~ 21

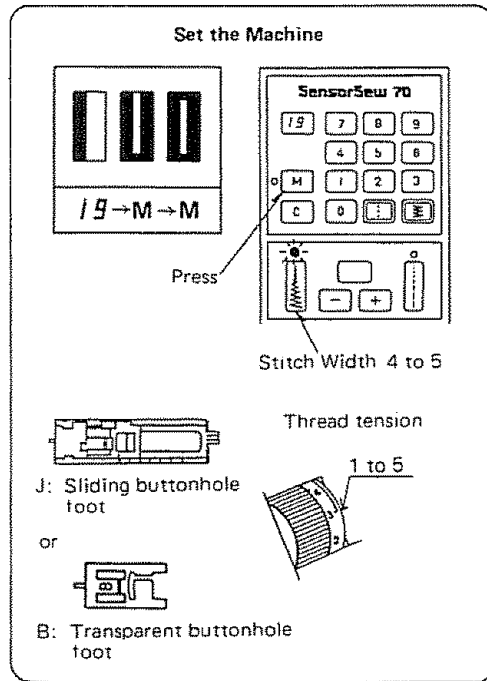

Use this procedure when you want to achieve a tailored, more attractive raised buttonhole.

Use filler cord (at least 15 inches of heavy thread).

Try a practice buttonhole first.

NOTE: For this buttonhole use stitch patterns 19 to 21. The sliding buttonhole foot is preferable, but B Foot can also be used. Don't repeat corded buttonholes by memory. Make them individually.

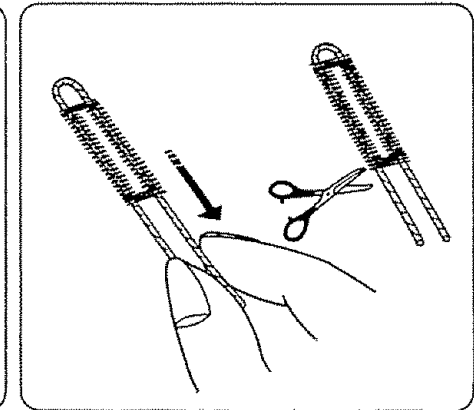
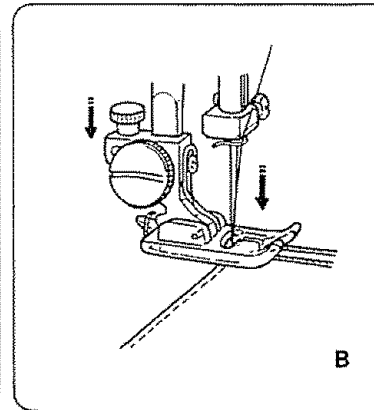
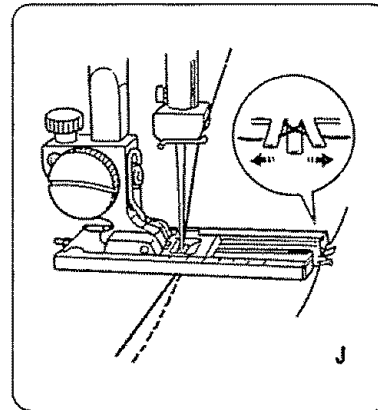

1. With the buttonhole foot raised, hook the filler cord on the cord spur at the back of the buttonhole foot.
2. Bring the ends toward you under the buttonhole foot until they clear the front end.
3. Hook the filler cord into the forks on the front of the J foot to hold them tight.

NOTE: For the B Foot, hold the cords tight in front of the foot as you sew.

4. Lower the needle into the garment where the buttonhole will start and lower the foot.
5. Sew the buttonhole according to the buttonhole sewing instructions on p. 65 to 67. Each side of the buttonhole and the bartacks will be sewn over the cord.
6. Remove the fabric from the machine and cut the sewing threads.
7. Pull the right end of the filler cord to tighten it.
8. Thread the end through a darning needle, draw to the wrong side of the fabric and cut.

NOTE: To adjust stitch density, see p. 68.





SECTION 5: LEARN THE STITCHES

Hemming and Edging Stitches 28 ~ 31

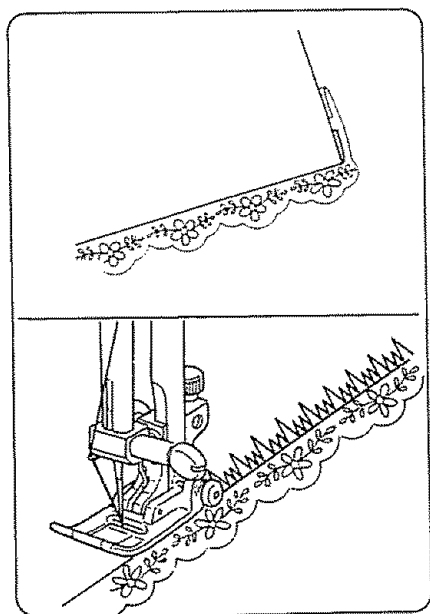
Hemming and Edging garments, tablecloths, napkins and craft items have often required careful hand sewing to produce a professional, finished look.

Now your Sensor Sew 70 can do these precision stitches much faster and more precisely than you ever dreamed possible.



			
<i>28</i>	<i>29</i>	<i>30</i>	<i>31</i>
G	G	A	F

The Stitches covered in this section are:

- Blind Hem Stitch 28 (stretch) 29
- Shell Stich 29
- Scallop Stitch 30
- Cut-Out Work Edging 31
- Applique 31

- Blind Hem Stitch (stretch) **28**
- Blind Hem Stitch (woven) **29**

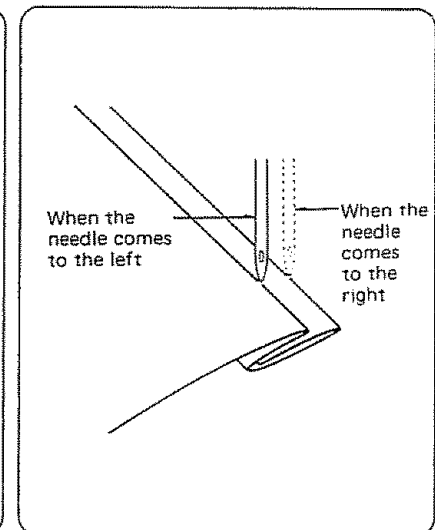
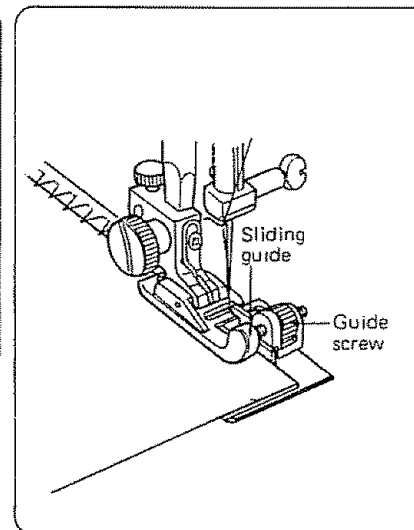
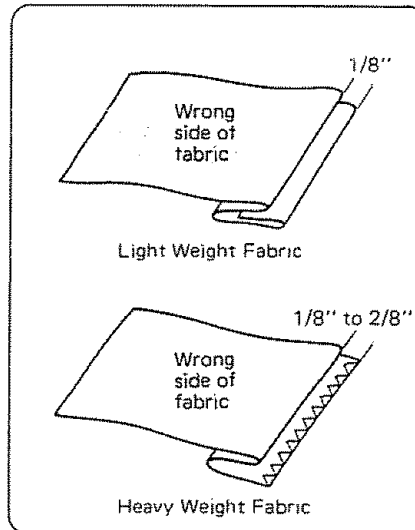
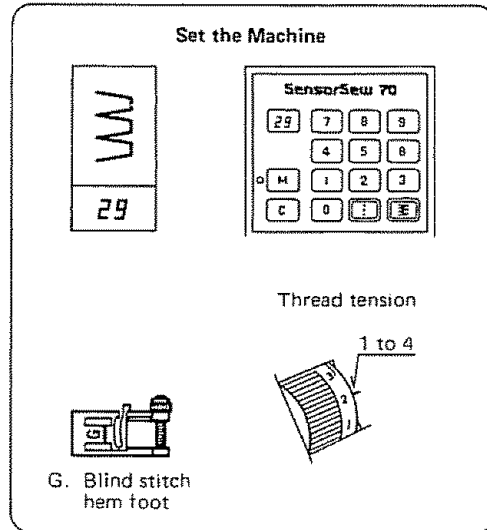

The Stitches and Their Uses

The stretch Blind Hem Stitch **28** is to be used for stretch fabrics because it is the stronger and more elastic of the blind hem stitches.

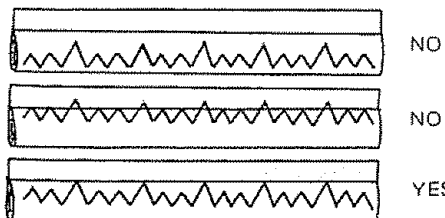

The regular blind hem stitch **29** is strong enough for woven fabrics.

Here's How

1. Finish the raw edge of your hem any way you desire. (See Overcasting, p. 61)
2. Measure, turn up your hem and pin.

NOTE: For light weight fabrics, you may need a double fold.

3. Fold the material (wrong side out) on the edge to be stitched, as shown, leaving 1/8" of the finished hem edge showing.
4. Turn the sliding guide screw so that the sliding guide is very close (1/16") to the left side of the blind hem foot.
5. Place the fold of the hem against the sliding guide so that the 1/8" extending edge shows on the right. The long zigzag stitch should barely pierce the folded edge of the fabric, but still sew on the 1/8" extended edge. See at left for proper stitch appearance.
6. After hemming, press both sides of the finished hem. The right side of the garment will show only the blind stitches.

Helpful Hint

Hemming Thin Fabrics:

Reduce pressure on the presser foot to avoid a distinct line.

Hemming and Edging Stitches 28 ~ 31 (Continued)

• Shell Stitch 29

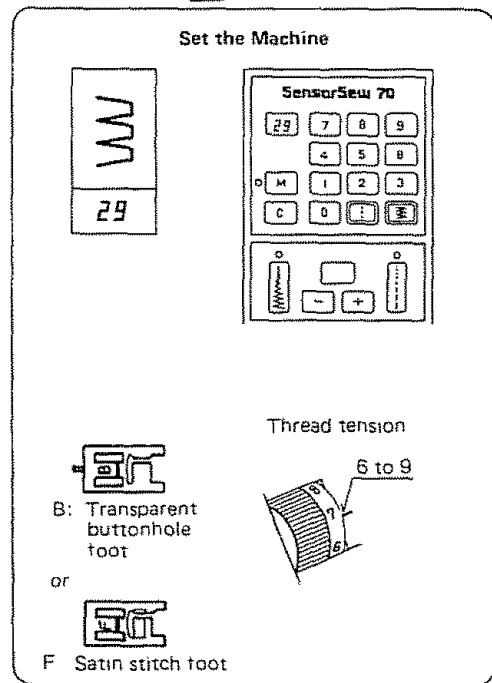

The Stitch and Its Uses

The Shell Stitch is formed by sewing a blind hem over folded fabric. Several rows of shell stitching are called shell tucks.

Shell stitching can be used to finish hems, sleeve and neck openings.

Shell tucking can be used to create scalloped tucks on blouses and lingerie.

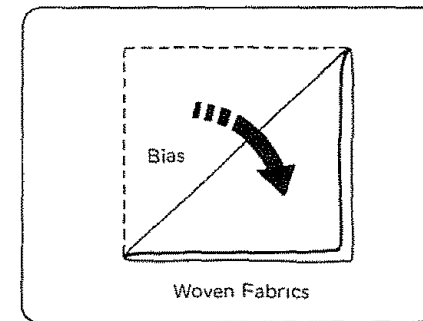
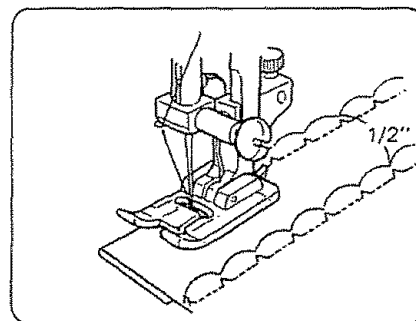

Here's How

1. For best effect —
 - set the stitch width and length as you desire.
 - you may need to tighten the top thread slightly.
 - allow the needle to just clear the folded edge of the fabric when it zigzags.
2. If you sew rows of shell stitches, space the rows 1/2" apart.

You can sew Shell Stitch on knits or soft silky wovens in any direction.

• Scallop Stitch **30**

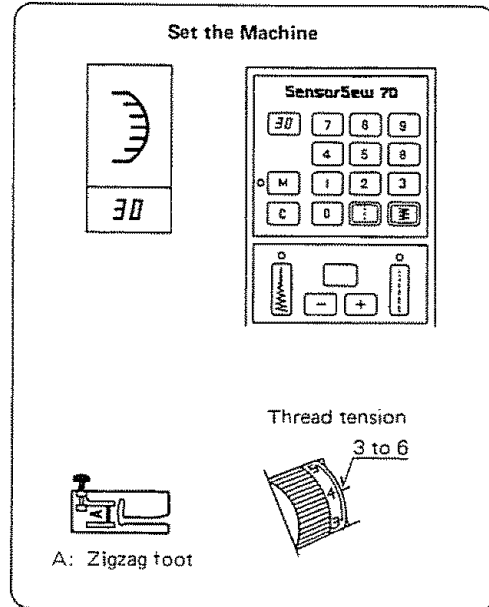

The Stitch and Its Uses

Use this attractive scallop stitch to create scallop edges or decorate your sewing projects, such as collars, pockets or placemats. You can create a delicate appearance on thin fabrics, such as chiffon, using a single layer of fabric with a tear-away backing for support while stitching.

You can also use this scallop stitch to sew decorative edgings on the hemlines of dresses or sleeves.

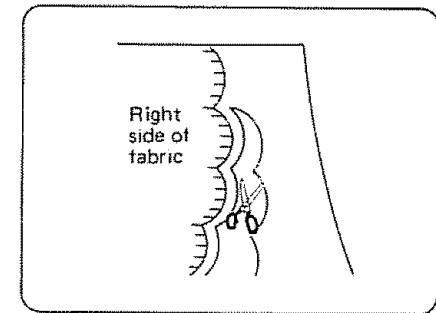
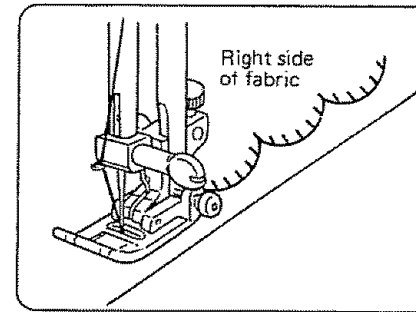

Here's How

1. Sew your scallops at least 3/8" from the folded edge.
2. After stitching, trim fabric close to the stitching. Be careful not to cut the thread.

Helpful Hints

For thin fabrics:

Use a single layer of fabric with a tear-away backing for support while stitching.

For hemlines and sleeves:

Use a tear-away backing, if necessary.

For collars, pockets or craft projects:

Place interfacing between the layers of fabric to provide stiffness.

SECTION 5 LEARN THE STITCHES

Hemming and Edging Stitches 28 ~ 31 (Continued)

• Cut-Out Work Edging and Applique 31

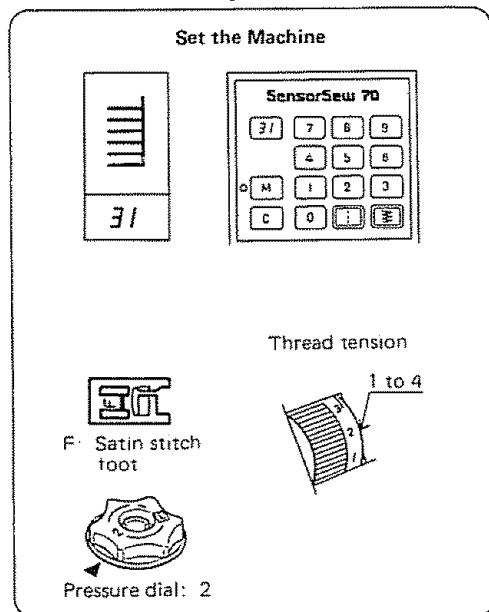

The Stitch and Its Uses

Cut-Out Work and Applique are the major uses for this stitch, but it can also be used to provide edging on many sewing projects, including placemats, blankets, collars, cuffs and pockets.

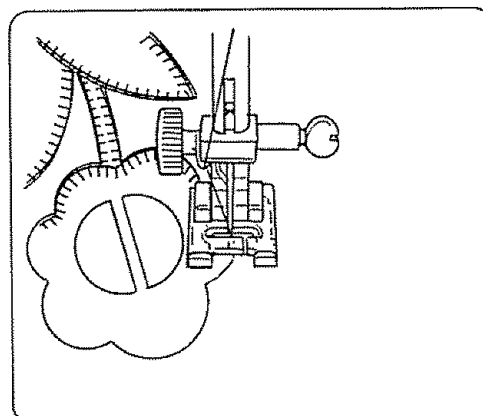

Here's How – For Applique

1. Use a fusible heavy weight interfacing behind each piece of your applique.
2. Cut the interfacing slightly smaller than the design pieces.
3. Tape or baste the applique in place and sew around each piece with stitch pattern 31.

NOTE: You may also use a satin stitch.

4. When sewing curves, leave the needle in the fabric, raise the presser foot and turn the fabric.
5. Lower the presser foot and stitch.

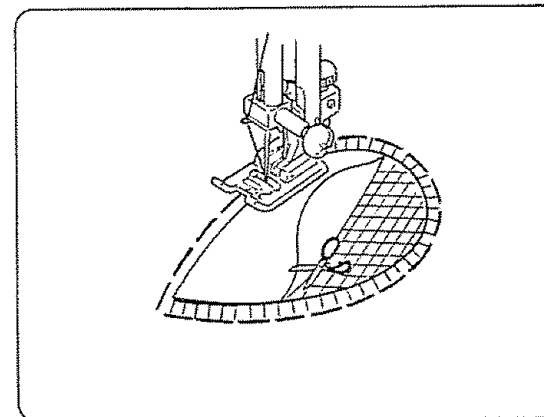

Here's How – For Cut-Out Work

1. Choose a simple design and trace the outline on the right side of the fabric.
2. Place a piece of tulle or organdy under the design and pin in place.

NOTE: You may want to use a contrasting insert fabric to accent your work.

3. Baste the layers together, stitching just outside the outline. Remove the pins.
4. Stitch around the design, using stitch pattern 31.

NOTE: You may also use a narrow satin stitch (see p. 60).

5. Remove basting and cut the fabric inside the design close to the stitching, using an embroidery scissors.

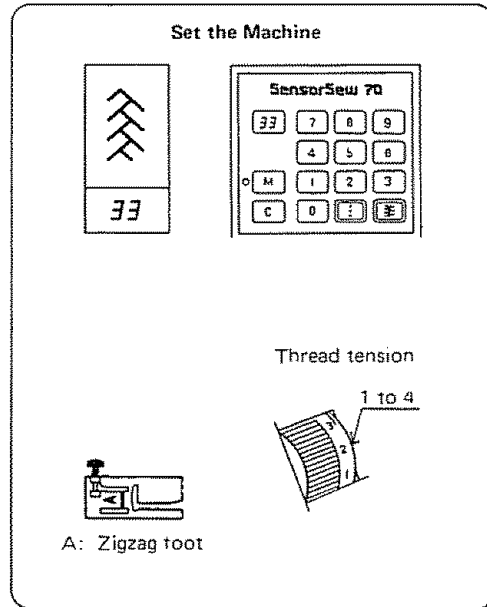
Reinforcing Stitches **33** and **40**• Feather Stitch **33**The Stitch and Its Uses

This stitch is strong, useful and decorative. It can reinforce stretch and woven fabrics. You can use it to sew spandex undergarments or decoratively hem elastic fabric. You may also use this stitch in patchwork quilting.

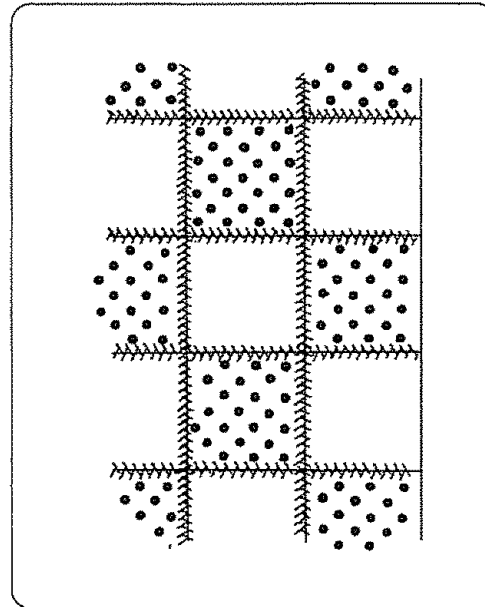
Here's How

1. Sew this pattern on a seam that is already joined and pressed flat.
2. Butt two folded edges together and use this stitch to join them.

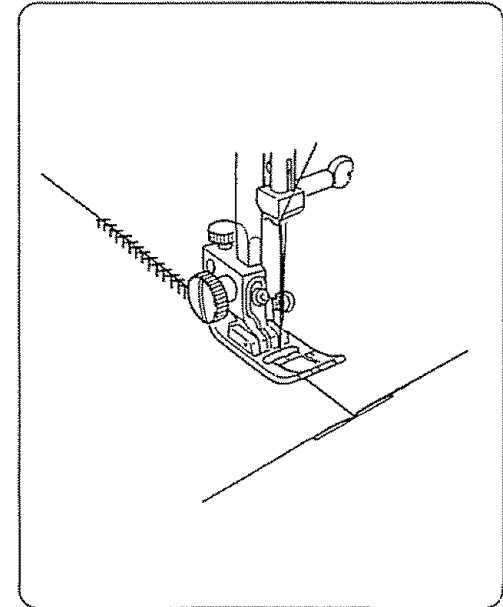

SECTION 5: LEARN THE STITCHES

Reinforcing Stitches **33** and **40** (Continued)

• Fagoting Stitch **40**

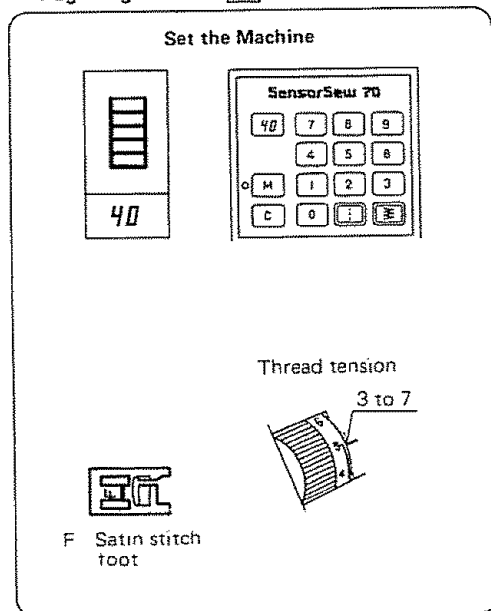

The Stitch and Its Uses

Use this stitch to join two pieces of fabric to create an open work appearance and add design interest.

For other stitches that may be used in fagoting, see stitch patterns **33** (p. 75).

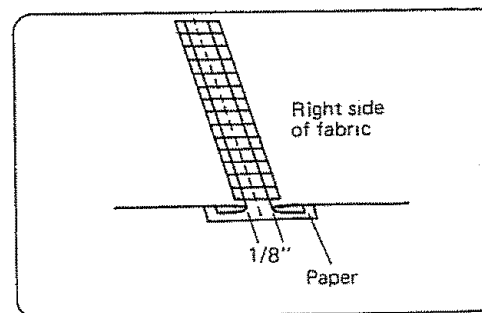

Here's How

1. Fold under each fabric edge 1/2" and press.
2. Pin the two edges to paper or tear-away backing 1/8" apart.
3. Sew slowly, guiding the fabric so the needle catches the folded edge on each side.

Helpful Hint

You may want to set the stitch on "7.0" for maximum effect.

• Elastic Casing Stitch **40**

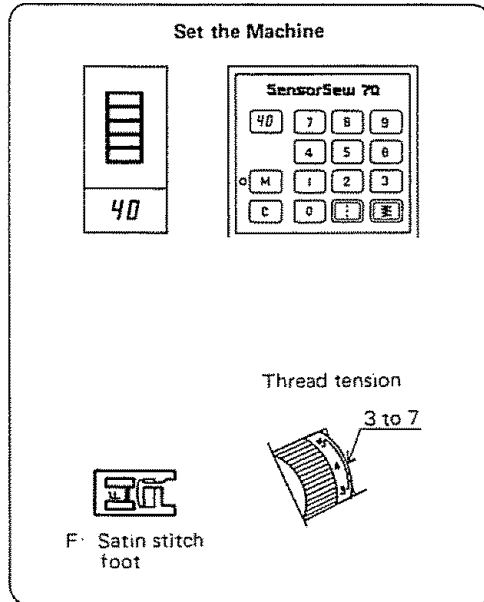

The Stitch and Its Uses

Use this stitch to replace bias tape casings in such areas as wrists and waists. In children's clothing, this stitch is especially helpful, because it reduces bulk.

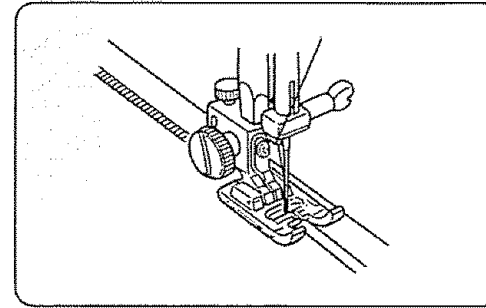

Here's How

1. Slide a piece of 1/8" elastic under the foot, then up through the slot in Foot F (satin stitch).
2. Sew the elastic on the wrong side of the fabric, pulling it gently to avoid sewing through the elastic.
3. Pull on the elastic to gather the fabric and bartack at both ends.

SECTION 5 LEARN THE STITCHES

Decorate with Geometric Patterns 34 ~ 39

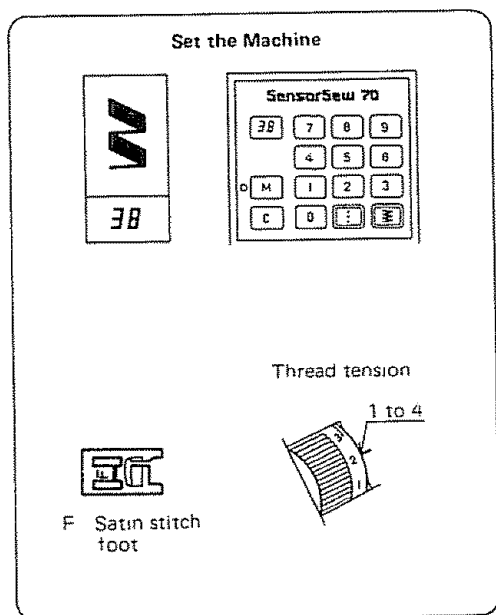

The Stitches and Their Uses

These stitches are purely decorative. You can sew one row or several or vary the stitch width and length for special effects. Experiment on a scrap of fabric to see what special effects are possible.

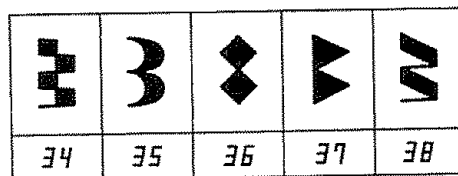

Here's How

1. Adjust the stitch width and length as you desire.
2. Practice the stitch on a scrap of fabric.
3. Mark the lines for decoration on the fabric, using a washable fabric marker.
4. Lower the needle at the starting point.
5. Lower the presser foot.
6. Lock the stitch at the beginning (press auto-lock).
7. Gently guide the fabric along the marked line.
8. Use the auto-lock to secure the row of stitches at the end.

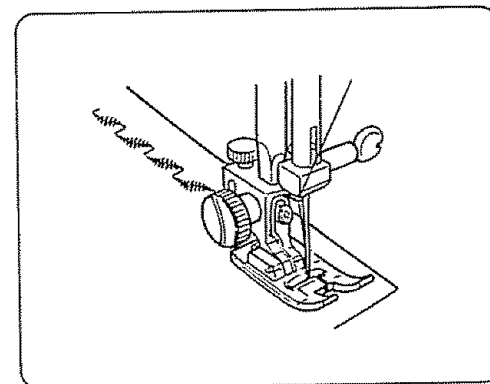

Helpful Hint

You may want to combine these geometric decorative stitches with other decorative stitches. See "Programming Decorative Stitch Patterns" (p. 82) for detailed instructions.

Cross Stitch 41

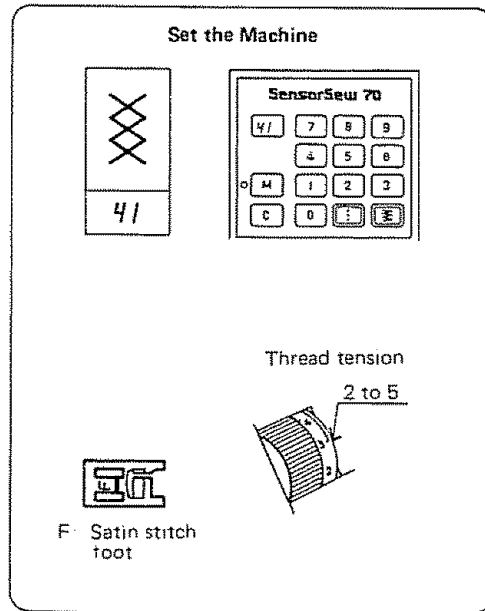
The Stitch and Its Uses

You can make beautiful designs with this embroidery stitch pattern, in half the time it would take if embroidered by hand. You can also combine cross stitches with the other decorative patterns and letters or numbers for attractive samplers and other sewing projects.

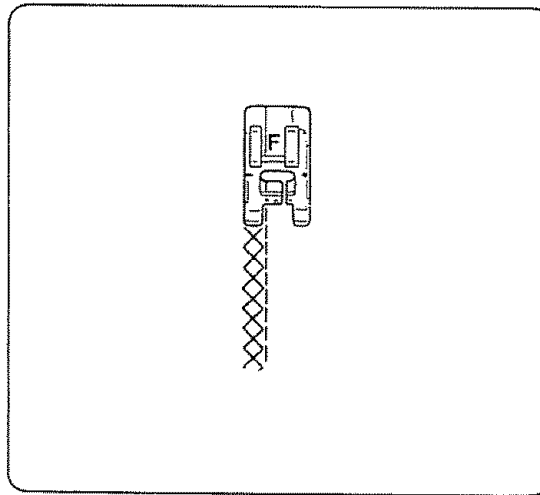
Here's How

1. Choose a plain close weave fabric such as linen or wool flannel for the background fabric.
2. If you choose light weight fabric, use a tear-away fabric backing for support.
3. Adjust the stitch width and length as you desire to match the pattern you have or plan.
4. Find the center of the design, or if the design is a border, choose a starting point.
5. Count the cross stitches from the center up and program the number.
(See p. 83, Pattern Single Units.)
Use Auto-Lock to begin and end.

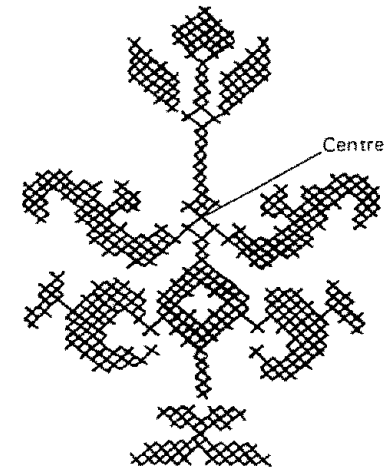
For Cross-Stitching Without a Pattern:

1. Start in the center of the design and sew the first row, letting the fabric feed naturally.
2. Then count the next row of stitches to the left or right.
3. Add or delete stitches by pressing the Clear button and reprogramming.
4. Begin each row by lowering the needle at the corner of a previous stitch.
5. Use the placement arrow "△" on Foot F to insure straight, even rows.

SECTION 5: LEARN THE STITCHES

Smocking [32], [42], [43], [48] (or any decorative stitch)

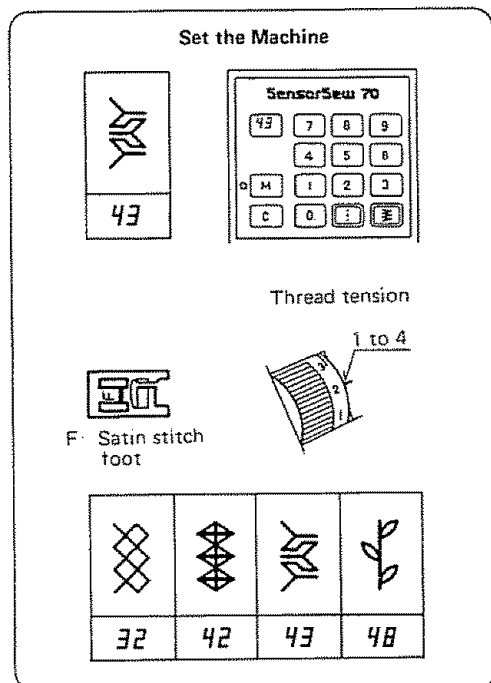

The Stitches and Their Uses

Smocking is a delicate decorative treatment for children's clothes or women's blouses.

Step I (1 to 6)

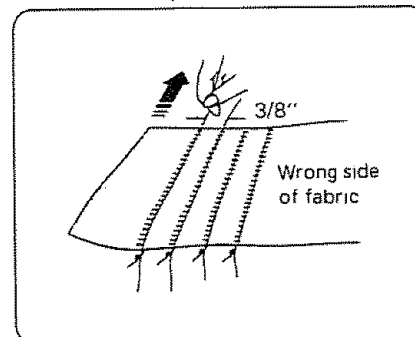

Step II (7 to 8)

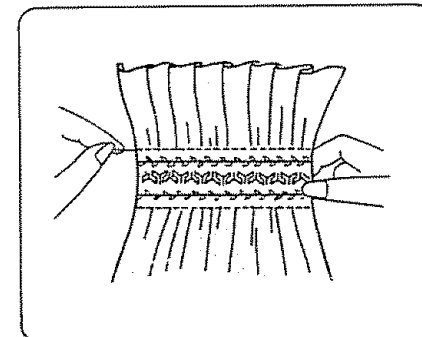

Here's How

1. Choose a soft, lightweight fabric such as batiste, gingham or challis.
2. Cut the fabric three times the finished width.
3. Set the stitch length control button at "4.5" and sew rows of straight gathering stitches 3/8" apart across the area to be smocked.

NOTE: Loosen the needle thread tension to make gathering easier.

4. Knot the threads along the edge.
5. Pull the bobbin threads and distribute the gathers evenly.
6. Secure the threads at the other end.
7. Sew the decorative stitches of your choice between the gathering stitches.
8. Pull out the gathering stitches.

Helpful Hint

These stitches can be used in combination with others for any decorative effect you desire.

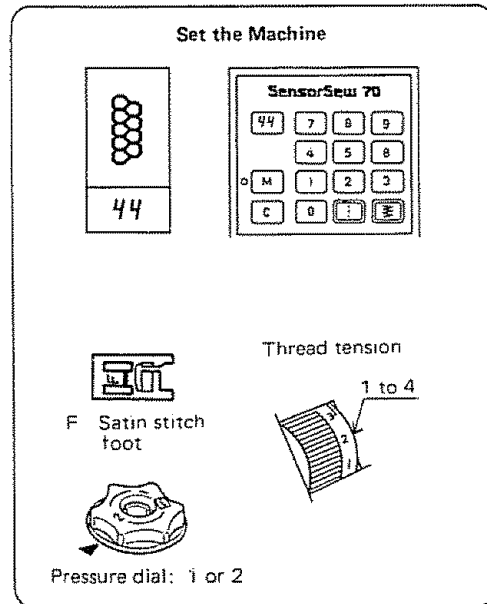
Sand Stitch **44**The Stitch and Its Uses

The sand stitch fills in outlined embroidery designs.

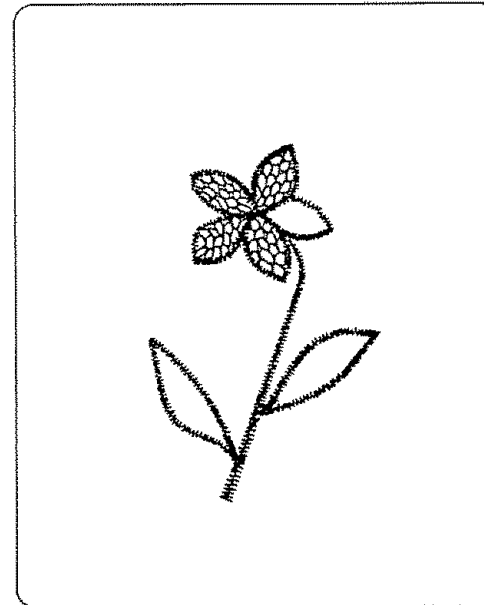
Here's How

1. Outline the pattern with a Satin Stitch **15**.
Set stitch width at "1.5".
Set stitch length at "0.3" or as you desire.
2. Fill in the design with the sand stitch.
3. Decrease the stitch width to fill in small spaces.
4. Sew in rows, starting at the edge, until the pattern is filled in.

SECTION 5 LEARN THE STITCHES

Program Decorative Stitch Patterns 45 ~ 47 etc.

To program stitch pattern combinations, press the pattern selection buttons in the order shown.

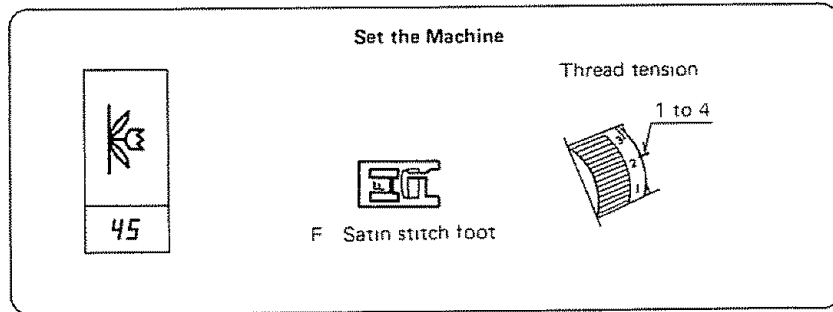

• One Cycle Stitching

1. Press the Auto-Lock.
2. Press Memory.
3. Press the stitch pattern.
4. Press Memory.
5. Press the Auto-Lock.
6. Press Memory.

See the Pattern Single Unit Chart.
You will sew one flower.

NOTE: The Auto-Lock stitch is already programmed into the buttonhole stitches and monograms, but not on any other stitches. You must press Auto-Lock to lock the decorative or any other stitches.

• Two Cycle Stitching

To sew two of any stitch pattern, press the memory button twice after selecting the stitch pattern numbers.

NOTE: Continue to press the foot control until the machine stops automatically.

Combine Stitch Patterns

1. Press the Auto-Lock.
2. Press Memory.
3. Press the stitch pattern.
4. Press Memory.
5. Press the next stitch pattern.
6. Press Memory.
7. Press the stitch pattern.
8. Press Memory.
9. Press the stitch pattern.
10. Press Memory.
11. Press the Auto-Lock.
12. Press Memory.



To repeat the same combination of stitches, just press the foot control again after stitching the first combination.

- Pattern Single Units
(Aid to Programming)

DECORATIVE STITCHES															
PATTERN No.	34	35	36	37	38	38	40	41	42	43	44	45	46	47	48

The patterns shown in the upper column are the units of each pattern sewn when the memory button is touched once.

Each buttonhole is automatically locked at the end. "Auto-Lock" stitch is already programmed on the buttonhole stitching but on no other stitch patterns shown here.

SECTION 5 LEARN THE STITCHES

Program Decorative Stitch Patterns 45 ~ 47 etc. (Continued)

- To Adjust a Distorted Pattern

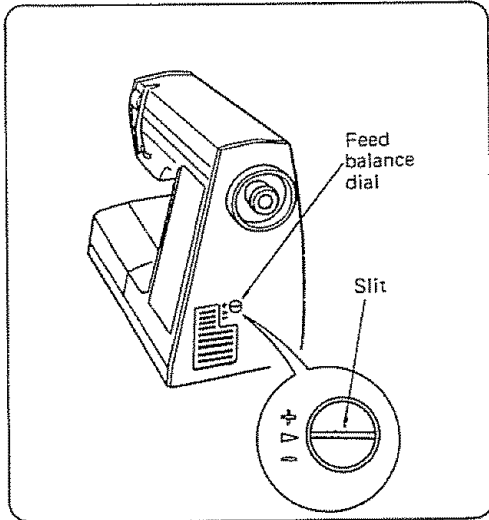

If decorative stitch patterns are uneven when you sew on a particular fabric, adjust them with the feed balance dial.

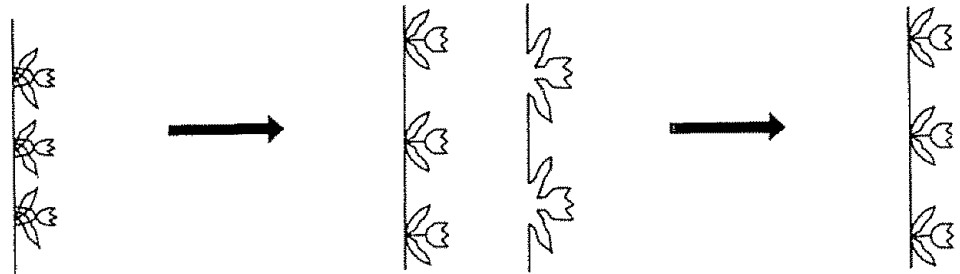

Compressed Patterns:

Correct by turning the feed balance dial toward the "+". Use the large screw driver in your accessory box.

Drawn Out Pattern:

Correct by turning the feed balance dial toward the "-".

Monogramming 00 ~ 09 , 49 ~ 76

Your machine will sew the 26 letters of the alphabet, the period and leave a space, plus the numbers from 0 to 9. You can program entire words and sentences.

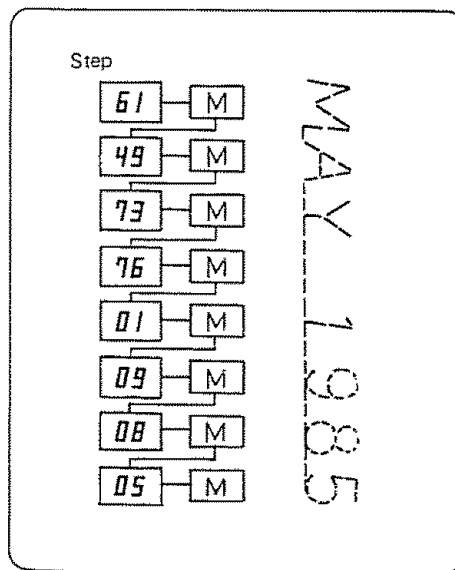

Each number and letter is automatically locked at the beginning and end so you can clip connecting threads.

00 Q	01 1	02 2	03 3	04 4	05 5	06 6	07 7	08 8	09 9
49 A	50 B	51 C	52 D	53 E	54 F	55 G	56 H	57 I	58 J
59 K	60 L	61 M	62 N	63 O	64 P	65 Q	66 R	67 S	68 T
69 U	70 V	71 W	72 X	73 Y	74 Z	75 .	76 —		

The chart above shows where to clip the connecting threads and where each pattern starts, marked by "o".

You can program words and sentences in the same way as you program other stitch patterns. Press the memory button after each stitch pattern selection up to 31 selections. See example.

SECTION 5 LEARN THE STITCHES

Monogramming 00 ~ 09 , 49 ~ 76 (Continued)

- Reduce the Size of Numbers and Letters

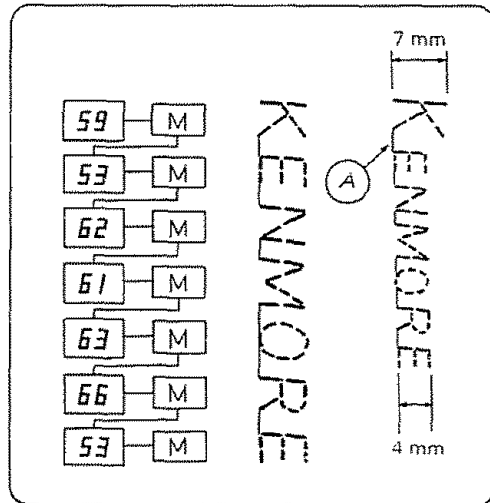

Here's How

1. Program the stitch pattern combinations.
2. Press the foot control.
3. When the needle comes to point **A** (see illustration) and the indicator screen shows pattern **53**, release the foot control at once.
4. Adjust the stitch width and length as desired.

NOTE: Good proportions are:
Stitch Width — "4" to "7"
Stitch Length — "1.5" to "2.5"

5. Press the foot control again.
6. Your remaining letters will be smaller.

Decrease the size of the numbers in the same way.

SECTION 6 PERFORMANCE PROBLEMS CHART

What to Do When

PROBLEM	PROBABLE CAUSE	CORRECTION
The machine does not work.	A single digit number was programmed. A number without pattern was selected.	Two digit number must be programmed. A number in the stitch package chart must be selected.
The machine does not work and the Pattern Indicator reads "Er".	The area of feed dogs is filled with dust and lint.	Clean the area of the feed dogs.
Irregular Stitches	Incorrect size needle. Improper threading. Loose upper thread tension. Pulling fabric. Light pressure on presser foot. Loose presser foot. Unevenly wound bobbin. Nicks or burrs at hole of needle plate.	Choose correct size needle for thread and fabric. Rethread machine. Tighten upper thread tension. Do not pull fabric; guide it gently. Increase pressure on presser foot. Reset presser foot. Rewind bobbin. Replace needle plate, or polish off burrs completely.
Breaking Needle	Pulling fabric. Incorrect size needle. Incorrect setting of needle. Loose presser foot.	Do not pull fabric; guide it gently. Choose correct size needle for thread and fabric. Reset needle. Reset presser foot.
Bunching of Thread	Upper and lower threads not drawn back under presser foot before starting seam.	When starting a seam be sure to draw both threads under and back of presser foot about 4" and hold until a few stitches are formed.
Puckering	Incorrect thread tension(s). Light pressure on presser foot. Using two different sizes or kinds of thread. Bent or blunt needle. Loose presser foot. Fabric too sheer or too soft.	Reset thread tension(s). Increase pressure on presser foot. Upper thread and bobbin thread should be same size and kind. Insert new needle. Reset presser foot. Use underlay of tissue paper.
Monograms and buttonholes are not identical during memory sewing.	Fabric feed is restricted in some way.	Check threads for tangles. Check feed dogs and clean, if necessary. Be sure fabric does not pile up behind the presser foot. See pages 65 ~ 69 for buttonholing instructions.

SECTION 6. PERFORMANCE PROBLEMS CHART

What to Do When (Continued)

PROBLEM	PROBABLE CAUSE	CORRECTION
Monograms and buttonholes not identical.	Machine was not allowed to complete the last few stitches.	Hold down the foot control until the machine has stopped.
Skipping Stitches	Incorrect size needle. Bent or blunt needle. Incorrect setting of needle. Tight upper thread tension. Light pressure on presser foot.	Choose correct size needle for thread and fabric. Insert new needle. Reset needle. Loosen upper thread tension. Increase pressure on presser foot.
Breaking Upper Thread	Starting to stitch too fast. Improper threading. Tight upper thread tension. Incorrect size needle. Sharp eye in needle. Nicks or burrs at hole of needle plate.	Start to stitch at a medium speed. Rethread machine. Loosen upper thread tension. Choose correct size needle for thread and fabric. Insert new needle. Replace needle plate, or polish off burrs completely.
Breaking Bobbin Thread	Improper bobbin case threading. Lint in bobbin case or shuttle.	Check bobbin case threading. Clean bobbin case and shuttle.
Fabric not Moving	Darning plate in place. Light pressure on presser foot. Thread knotted under fabric. Push-pull clutch is disengaged.	Remove darning plate. Increase pressure on presser foot. Place both threads back under presser foot before beginning to stitch. Push in the clutch.
Machine Jamming Knocking Noise	Thread caught in shuttle. Lint in bobbin case or shuttle.	Disassemble and clean shuttle. Clean bobbin case and shuttle.
Buttonholes are not identical in length and shape.	Fabric is pulling and distorting the automatic fabric feed.	<ol style="list-style-type: none"> 1. Keep the fabric from falling off the edges of the sewing surface. 2. Bunch the fabric slightly all around the needle (see illustration on page 67).
	Fabric is too thick near the seam and the buttonholes.	<ol style="list-style-type: none"> 1. Use the B Foot in these instances. 2. Start the buttonhole so that you sew <u>toward</u> the edge of the fabric. 3. Put standard writing paper (not tissue paper) under the garment to aid fabric feed (for woven and stretch fabrics). 4. Do not use the Memory function. Sew each button individually.

Replace the Light Bulb

1. Unplug the machine and open the face cover.

CAUTION! The light bulb will be HOT. Protect your fingers when you handle it.

2. Push the bulb up and turn the bulb counter-clockwise to remove it.
3. Put the new bulb in by turning clockwise and pushing up.

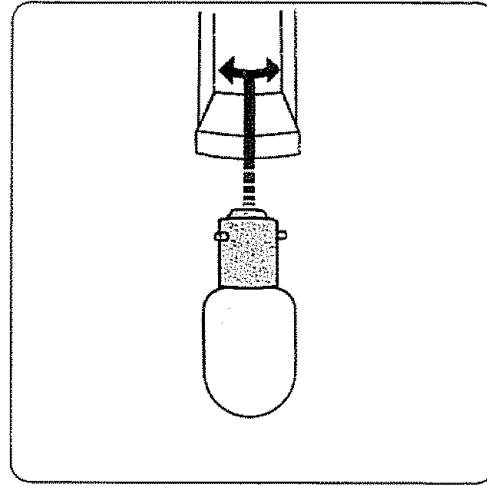

SECTION 7. CARE FOR YOUR MACHINE

Clean the Bobbin Holder

To insure that your machine operates at its best, you need to keep the essential parts clean at all times.

The bobbin area can attract dust and lint. Your machine can become sluggish or knock loudly if a thread is caught.

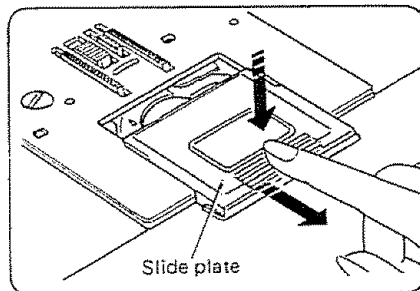

Follow these directions:

1. Turn off the power or unplug the machine.
2. Remove the bobbin cover plate by firmly pulling it toward you.
3. Remove the bobbin.

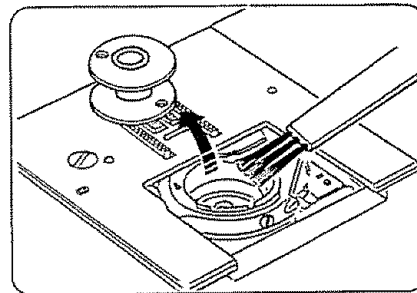

4. Brush or vacuum the dust and lint out of the bobbin holder.
5. Replace the bobbin.

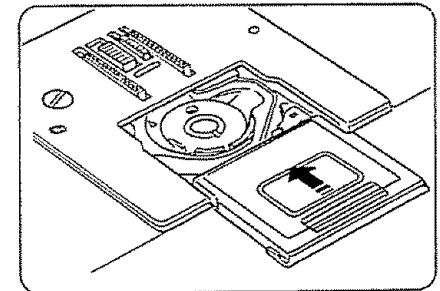

6. Slide on the bobbin cover plate by pushing it into the grooves.

Clean the Hook Race and Feed Dogs

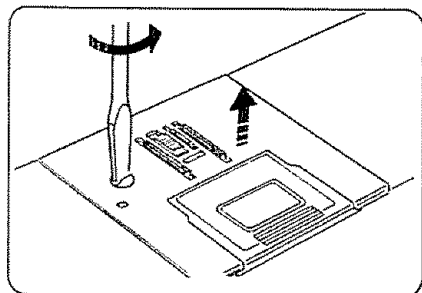

1. Unplug the machine and remove the presser foot and needle.
2. Remove the bobbin face cover plate.
3. Remove the screw on the left side of the needle with the large screw driver from your accessory box.
4. Remove the needle plate.

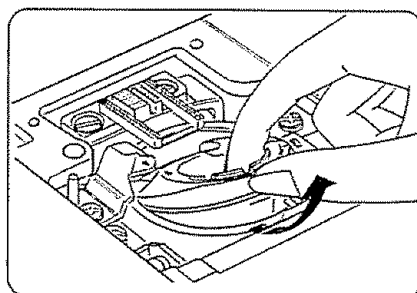

5. Take out the bobbin. Lift up the bobbin holder and remove it.

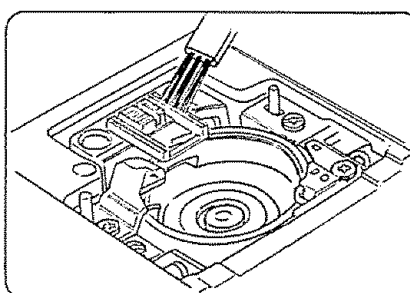

6. Use the lint brush in the accessory box to clean the feed dogs, hook race and bobbin holder. Also use a soft, dry cloth.

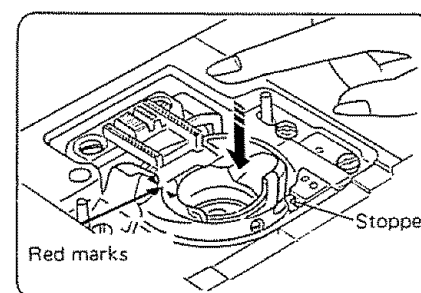

7. Line up the red marks and place the bobbin holder so the knob fits next to the stopper in the hook race, as shown above.

SECTION 7. CARE FOR YOUR MACHINE

Oil the Underside

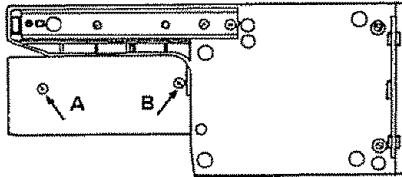

Fig. 1

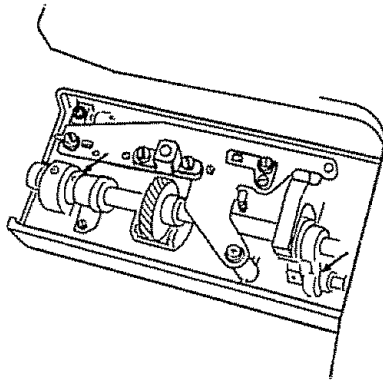
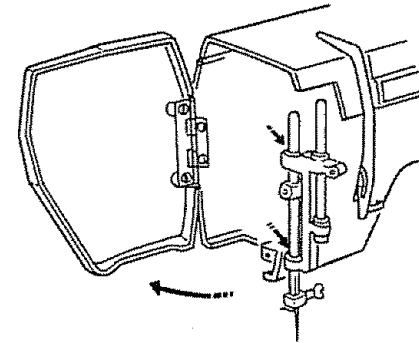

Fig. 2

1. Tilt the machine head back.
2. Remove the bottom covers by loosening the two screws, A and B, under the free arm. (Fig. 1)
3. Oil at the arrows shown in the illustration. (Fig. 2)

NOTE: No other oiling is required.

Oil the Face Cover Plate



1. Oil at those points indicated by short arrows in the illustration above.

No other oiling is required.

DO NOT REMOVE the top cover or base cover. No customer service is required in these areas.

PARTS LIST

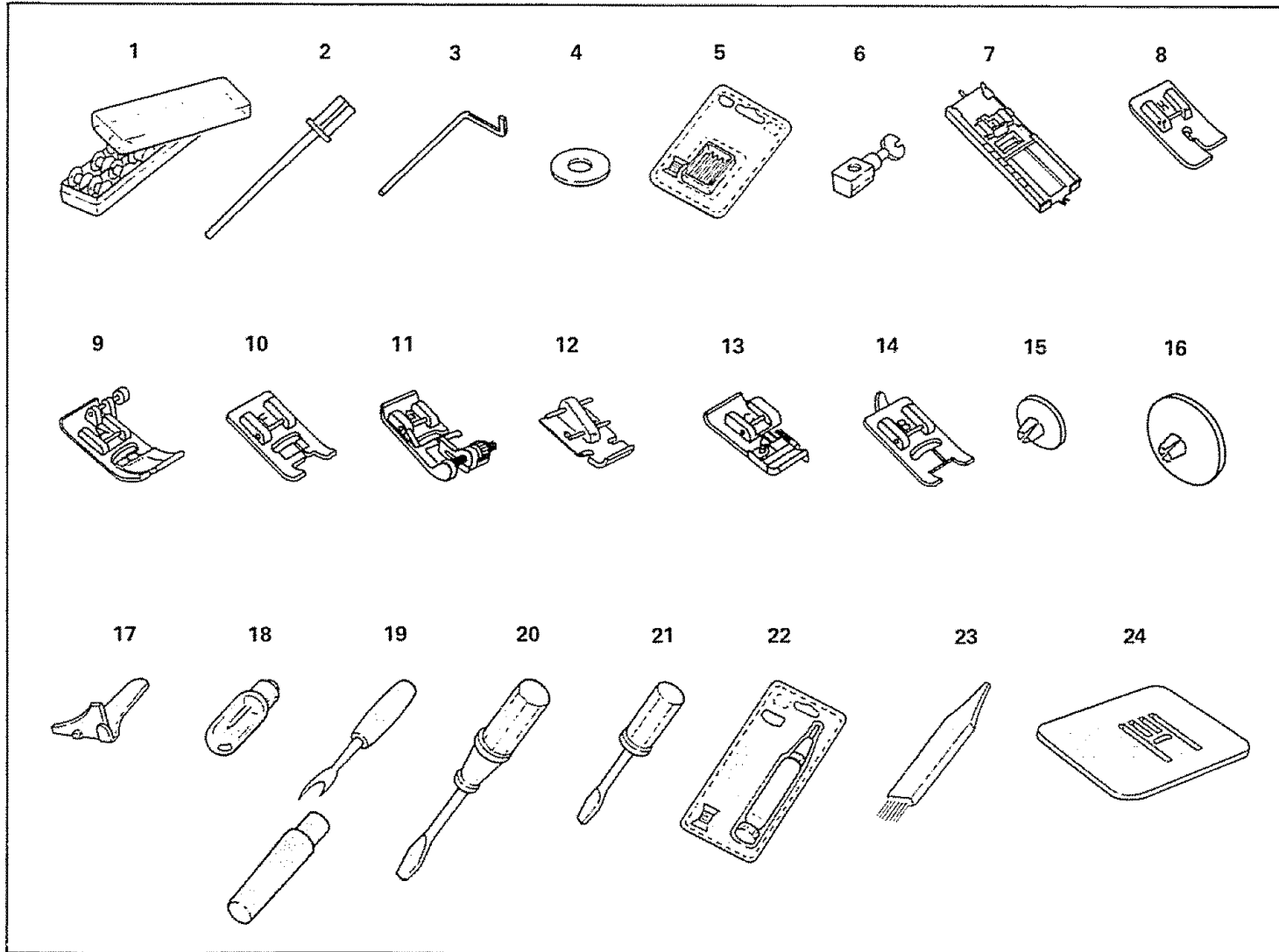

PARTS LIST (Continued)

All parts listed herein may be ordered from any Sears Roebuck and Co. store or service center.

WHEN ORDERING REPAIR PARTS, ALWAYS GIVE THE FOLLOWING INFORMATION:

1. PART NUMBER
2. PART DESCRIPTION
3. MODEL NUMBER
4. NAME OF ITEM

If the parts you need are not stocked locally, your order will be electronically transmitted to a Sears Repair Parts Distribution Center for expedited handling.

Ref. No.	Part No.	Description
1	*20-6868	Bobbin box with 10 bobbins
2	625031005	Thread spool pin
3	802422002	Quilter
4	102403202	Spool pin felt
5	813404013	No. 11 Stretch fabric needles (BLU)
	6551	No. 11 Single needles (ORG)
	6552	No. 14 Single needles (RED)
	6553	No. 16 Single needles (PUR)
	6554	No. 18 Single needles (GRN)
6	823502002	Needle clamp with screw
7	820822013	Sliding buttonhole foot
8	823801004	Straight foot
9	822508005	Zigzag foot
10	822804004	Satin stitch foot
11	820817015	Blind stitch hem foot
12	823803006	Zipper foot
13	822801001	Overedge foot
14	820801005	Transparent buttonhole foot
15	822019004	Small spool holder
16	822020008	Large spool holder
17	*6864	Needle threader
18	6797	Light bulb
19	6830	Buttonhole opener
20	41670	Large screw driver
21	41669	Small screw driver
22	*6889	Oil and lint brush
23	802424004	Lint brush
24	823805008	Darning plate

* These items are not furnished with the machine, but may be ordered per instructions above.

INDEX

A

Accessories 6
 Alphabet & numbers 85, 86
 Appliqueing 74
 "Auto-Lock" button 5, 34

B

Base 5
 Basting 37, 44, 45
 Blind hemming 44, 47, 71
 Blind stitch hem foot 12, 15, 45, 47
 Bobbin 6, 18~21
 Bobbin cover plate 5, 90
 Bobbin thread 25
 Bobbin winding 19, 20
 Buttonhole 44, 46, 65~69
 Buttonhole foot, sliding 46, 65
 Buttonhole foot, transparent 46, 65
 Button sewing 39, 44

C

Cleaning bobbin holder, hook race 90, 91
 Clear button 31
 Cross stitching 44, 48, 79
 Cut-out work 44, 47, 74

D

Darning 38, 44
 Darning plate 6, 37, 38, 39
 Decorative stitching 44, 48, 78
 Distorted pattern 84

E

Elastic casings 44, 48, 77
 Extension table 10

F

Fabric, needle, thread and
 stitch length chart 17
 Face cover plate 5
 Fagoting 44, 48, 76
 Feather stitching 48, 75
 Feed balance dial 6, 8, 68
 Foot control 6, 8
 Foot holder 22
 Foot storage compartment 12
 Free arm sewing 10, 11

G

Gathering 55

H

Hand wheel 5

K

Knit stitching 64

L

Light and power switch 7
 Light bulb 89

M

Memory button 31
 Monogramming 85, 86
 Multiple zigzag stitching 46, 62

N

Needle 16, 17
 Needle clamp 17
 Needle plate 5, 35
 Needle position 32
 Needle, thread and fabric chart 17

O

Oiling 92
 Outline stretch stitching 45, 56
 Overedge foot 13
 Overedge seam 46, 63

P

Parts list 93, 94
 Pattern indicator screen 30
 Pattern memory 31
 Pattern reduction 86
 Pattern selection 29~31
 Pattern selection button 5, 28
 Performance problems 87, 88
 Pintucking 45, 53
 Plug connector 7
 Portable case 4
 Power switch 7
 Presser foot 12~15
 Presser foot lever 6, 9
 Pressure control dial 5, 8
 Program sewing 82, 83

INDEX (Continued)

Q

Quilter 14
Quilting 54

R

Replacing bobbin holder 91
Reverse stitch button 5, 34

S

Saddle stitching 45, 58
Sand stitching 81
Satin stitch foot 14
Satin stitching 60
Scallop stitching 73
Seam guides 35
Sewing functions chart 44
Sewing light 5, 7
Sewing on heavy fabrics 36
Shell stitching 47, 72
Smocking stretch stitching 48, 80
Spool holder 5, 18
Spool pins 6, 18
Stitch length adjustment 32, 33
Stitch length/width indicator 28, 32, 33
Stitch length/width control
 buttons 28, 32, 33
Stitch pattern chart 45~49
Stitch width adjustment 32
Straight stitching 45, 50~55
Straight stitch button 28, 31
Straight stretch stitching 45, 57
Stretch stitching 44, 56~58, 63, 64
 72~77, 80, 81

T

Thread guide 6, 24
Thread tensions 26, 27
Thread tension dial 5, 26
Top cover 5
Topstitching 51, 52
Top thread 24~26
Turning a square corner 35

U

Up & down needle position button 5, 29

Z

Zigzag foot 13
Zigzag stitch button 28, 31
Zigzag stitching 46, 59~64
Zigzag overcasting 61
Zipper application 40~42

WARRANTY

FULL 25-YEAR WARRANTY ON SEWING MACHINE HEAD

For 25 years from the date of purchase, Sears will, free of charge, repair defects in material or workmanship which appear in the sewing machine head.

FULL TWO YEAR WARRANTY ON ELECTRICAL EQUIPMENT OF SEWING MACHINE

For two years from the date of purchase, Sears will, free of charge, repair defects in material or workmanship which appear in the electrical and electronic equipment of the sewing machine, including motor, wiring, switch and speed control and printed circuit boards.

FULL 90-DAY WARRANTY ON ALL PARTS AND MECHANICAL ADJUSTMENTS

For 90 days from the date of purchase, Sears will, free of charge, replace any parts and provide mechanical service necessary for proper operation of the sewing machine, except for normal maintenance.

To obtain warranty service described above, SIMPLY CONTACT THE NEAREST SEARS STORE OR SERVICE CENTER IN THE UNITED STATES. This warranty applies only while this product is in use in the United States.

This warranty gives you specific legal rights, and you may also have other rights which vary from state to state.

SEARS, ROEBUCK AND CO., Dept. 698/731A, Sears Tower, Chicago, IL 60684

SEWING MACHINE

Now that you have purchased your Kenmore Sewing Machine, should a need ever exist for repair parts or service, simply contact any Sears Service Center and most Sears, Roebuck and Co., Stores. Be sure to provide all pertinent facts when you call or visit.

The model number of your Sewing Machine will be shown on your nomenclature plate on the back of your Sewing Machine. See page 6 for location.

WHEN ORDERING REPAIR PARTS, ALWAYS GIVE THE FOLLOWING INFORMATION:

* MODEL NUMBER *NAME OF ITEM *PART DESCRIPTION

If the parts you need are not stocked locally, your order will be electronically transmitted to a Sears Repair Parts Distribution Center for handling.

SEARS, ROEBUCK AND CO., Chicago, IL60684 U.S.A.