



GAS RANGE

Use & Care Guide

COCINA (ESTUFA) DE GAS

Guía para el Uso y Cuidado

Models, Modelos **362.**61020, 61021, 61120, 61121, 71090, 71091, 71330,
71331, 71332, 72220, 72221, 72222, 72224, 72230,
72231, 72232, 72239, 73210, 73211, 73212, 73219,
73220, 73221, 73222, 73224

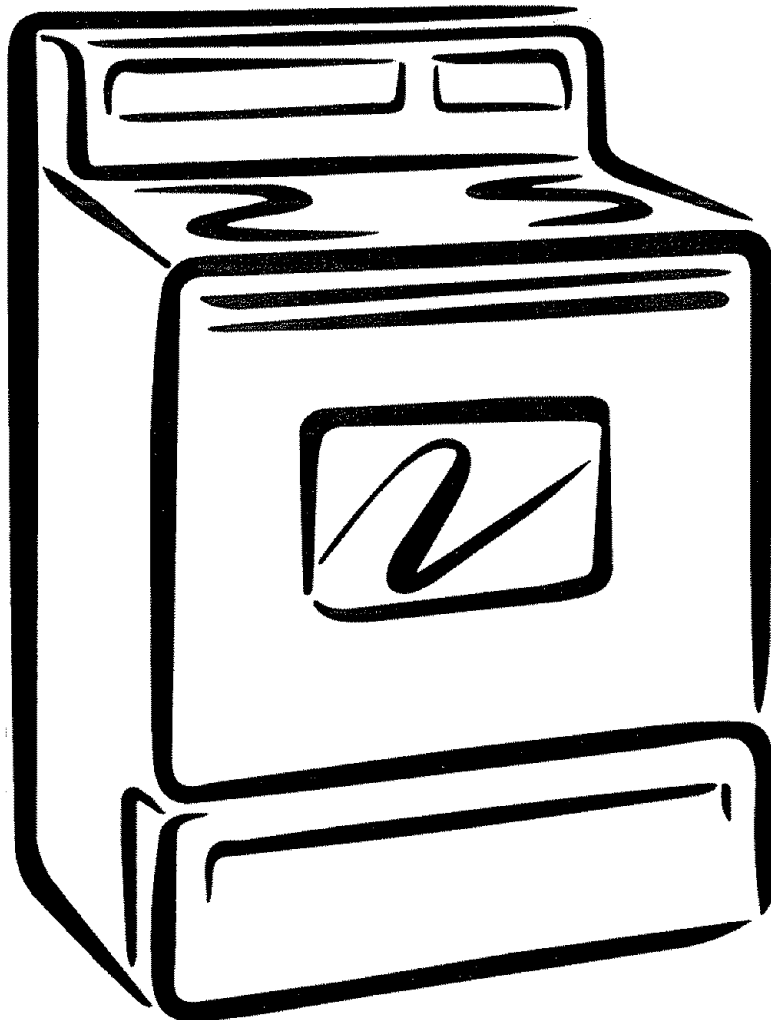

ENGLISH ESPAÑOL

TABLE OF CONTENTS

Safety Instructions

Anti-Tip Device	2, 3, 31, 39
Important Safety Instructions	2-6, 30

Care & Maintenance

Before You Call for Service	40, 41
Care and Cleaning	21-27
Consumer Services	84
Repair Services	84
Thermostat Adjustment	16
Warranty	42

Installation Instructions

Air Adjustment	36, 38
Anti-Tip Device	31, 39
Connect the Range to Gas	32-34
Dimensions & Clearances	29

Installation Instructions (cont.)

Electrical Connections	34, 35
For Your Safety	28
LP	39

Operation

Baking	14, 15
Broiling/Broiling Guide	19, 20
Clock and Timer	10
Features of Your Range	7
Roasting, Roasting Guide	17, 18
Surface Cooking	8, 9

En Español

Instrucciones en español	43
--------------------------	----

PRODUCT RECORD

For your convenience and future reference, please write down your model and serial numbers in the space provided. The model number and serial number of your gas range can be found on a plate fastened to the front frame behind the broiler drawer, storage drawer, or kick panel.

MODEL NUMBER:

SERIAL NUMBER:

IMPORTANT SAFETY INSTRUCTIONS



▲ WARNING

- ALL RANGES CAN TIP
- INJURY TO PERSONS COULD RESULT
- INSTALL ANTI-TIP DEVICES PACKED WITH RANGE
- SEE INSTALLATION INSTRUCTIONS



WARNING: If the information in this manual is not followed exactly, a fire or explosion may result causing property damage, personal injury or death.

— Do not store or use gasoline or other flammable vapors and liquids in the vicinity of this or any other appliance.

— WHAT TO DO IF YOU SMELL GAS

- Do not try to light any appliance.
- Do not touch any electrical switch; do not use any phone in your building.
- Immediately call your gas supplier from a neighbor's phone. Follow the gas supplier's instructions.
- If you cannot reach your gas supplier, call the fire department.

— Installation and service must be performed by a qualified installer, service agency or the gas supplier.

IMPORTANT SAFETY INSTRUCTIONS

Read all instructions before using this appliance.

IMPORTANT SAFETY NOTICE

- The California Safe Drinking Water and Toxic Enforcement Act requires the Governor of California to publish a list of substances known to the state to cause cancer, birth defects or other reproductive harm, and requires businesses to warn customers of potential exposure to such substances.

Gas appliances cause minor exposure to four of these substances, namely benzene, carbon monoxide, formaldehyde and soot, caused primarily by the incomplete combustion of natural gas or LP fuels. Properly adjusted burners, indicated by a bluish rather than a yellow flame, will minimize incomplete combustion. Exposure to these substances can be minimized further by venting with an open window or using a ventilation fan or hood.

When You Get Your Range

- Have the installer show you the location of the range gas shut-off valve and how to shut it off if necessary.
- Have your range installed and properly grounded by a qualified installer in accordance with the Installation Instructions. Any adjustment and service should be performed only by qualified gas range installers or service technicians.
- Plug your range (electronic ignition models only) into a 120-volt grounded outlet only. Do not remove the round grounding prong from the plug. If in doubt about the grounding of the home electrical system, it is your personal responsibility and obligation to have an ungrounded outlet replaced with a properly grounded, three-prong outlet in accordance with the National Electrical Code. In Canada, the appliance must be electrically grounded in accordance with the Canadian Electrical Code. Do not use an extension cord with this appliance.
- Do not attempt to repair or replace any part of your range unless it is specifically recommended in this manual. All other servicing should be referred to a qualified technician.

- Be sure all packing materials are removed from the range before operating it to prevent fire or smoke damage, should the packing material ignite.
- Locate the range out of kitchen traffic path and out of drafty locations to prevent pilot outage (on models with standing pilots) and poor air circulation.
- After prolonged use of a range, high floor temperatures may result and many floor coverings will not withstand this kind of use. Never install the range over vinyl tile or linoleum that cannot withstand such type of use. Never install it directly over interior kitchen carpeting.
- Be sure your range is correctly adjusted by a qualified installer for the type of gas (natural or LP), that is to be used. Your range can be converted for use with either type of gas. See the Installation Instructions.

WARNING: These adjustments must be made by a qualified service technician in accordance with the manufacturer's instructions and all codes and requirements of the authority having jurisdiction. Failure to follow these instructions could result in serious injury or property damage. The qualified agency performing this work assumes responsibility for the conversion.

▲ WARNING



All ranges can tip and injury could result. To prevent accidental tipping of the range, attach it to the wall and floor by installing the Anti-Tip device supplied.



To check if the device is installed and engaged properly, remove the broiler drawer and inspect the rear leveling leg. Make sure it fits securely into the slot.

If you pull the range out from the wall for any reason, make sure the device is properly engaged when you push the range back against the wall. If it is not, there is a possible risk of the range tipping over and causing injury if you or a child stand, sit or lean on an open door. Please refer to the Anti-Tip device information in this manual. Failure to take this precaution could result in tipping of the range and injury.

(continued next page)

IMPORTANT SAFETY INSTRUCTIONS

Using Your Range

- **Do not leave children alone or unattended where a range is hot or in operation.** They could be seriously burned.
- **Do not allow anyone to climb, stand or hang on the door, storage or broiler drawer (depending on model) or cooktop.** They could damage the range and even tip it over, causing severe personal injury.
- **Let the burner grates and other surfaces cool before touching them or leaving them where children can reach them.**
- **CAUTION: ITEMS OF INTEREST TO CHILDREN SHOULD NOT BE STORED IN CABINETS ABOVE A RANGE OR ON THE BACKSPASH OF A RANGE—CHILDREN CLIMBING ON THE RANGE TO REACH ITEMS COULD BE SERIOUSLY INJURED.**
- **Never wear loose fitting or hanging garments while using the appliance.** Be careful when reaching for items stored in cabinets over the cooktop. Flammable material could be ignited if brought in contact with flames or hot oven surfaces and may cause severe burns.
- **Do not use water on grease fires. Never pick up a flaming pan.** Turn the controls off. Smother a flaming pan on a surface unit by covering the pan completely with a well-fitting lid, cookie sheet or flat tray. Use a multi-purpose dry chemical or foam-type fire extinguisher.
- Flaming grease outside a pan can be put out by covering it with baking soda or, if available, by using a multi-purpose dry chemical or foam-type fire extinguisher.
- Flame in the oven or broiler drawer can be smothered completely by closing the oven door or drawer and turning the oven off or by using a multi-purpose dry chemical or foam-type fire extinguisher.
- **Do not store flammable materials in an oven, broiler drawer or near the cooktop.**
- **Do not store or use combustible materials, gasoline or other flammable vapors and liquids in the vicinity of this or any other appliance.**
- **Do not let cooking grease or other flammable materials accumulate in or near the range.**
- **Large scratches or impacts to glass doors can lead to broken or shattered glass.**

- **Cook meat and poultry thoroughly**—meat to at least an INTERNAL temperature of 160°F and poultry to at least an INTERNAL temperature of 180°F. Cooking to these temperatures usually protects against foodborne illness.
- **For your safety, never use your appliance for warming or heating the room.**

Surface Cooking

- **Always use the LITE position (on models with electronic ignition) or the HI position (on models with standing pilots) when igniting the top burners and make sure the burners have ignited.**
- **Never leave the surface burners unattended at high flame settings.** Boilovers cause smoking and greasy spillovers that may catch on fire.
- **Adjust the top burner flame size so it does not extend beyond the edge of the cookware.** Excessive flame is hazardous.
- **Use only dry pot holders**—moist or damp pot holders on hot surfaces may result in burns from steam.
- **Do not let pot holders come near open flames when lifting cookware.** Do not use a towel or other bulky cloth in place of a pot holder.
- **To minimize the possibility of burns,** ignition of flammable materials and spillage, turn cookware handles toward the side or back of the range without letting them extend over adjacent burners.
- **Always turn the surface burners to OFF before removing cookware.**
- **Carefully watch foods being fried at a high flame setting.**
- **Never block the vents (air openings) of the range.** They provide the air inlet and outlet that are necessary for the range to operate properly with correct combustion. Air openings are located in the following places:
 - Oven vent at the rear of the cooktop.
 - Air intake under the broiler drawer.
 - Air vent at the top of the oven door.
- **Do not lift the cooktop on sealed burner models.** Lifting the cooktop can lead to damage and improper operation of the range.

IMPORTANT SAFETY INSTRUCTIONS

- **Do not use a wok on models with sealed burners if the wok has a round metal ring that is placed over the burner grate to support the wok.** This ring acts as a heat trap, which may damage the burner grate and burner head. Also, it may cause the burner to work improperly. This may cause a carbon monoxide level above that allowed by standards, resulting in a health hazard.
 - **Foods for frying should be as dry as possible.** Frost on frozen foods or moisture on fresh foods can cause hot fat to bubble up and over the sides of the pan.
 - **Use the least possible amount of fat for effective shallow or deep fat frying.** Filling the pan too full of fat can cause spillovers when food is added.
 - **If a combination of oils or fats will be used in frying,** stir together before heating or as fats melt slowly.
 - **Always heat fat slowly and watch as it heats.**
 - **Use a deep-fat thermometer whenever possible** to prevent overheating fat beyond the smoking point.
 - **Never try to move a pan of hot fat, especially a deep fat fryer.** Wait until the fat is cool.
 - **When using glass cookware,** make sure it is designed for top-of-range cooking.
 - **Use proper pan size.** Avoid pans that are unstable or easily tipped. Select cookware having flat bottoms large enough to properly contain food and avoid boilovers and spillovers and large enough to cover burner grates. This will both save cleaning time and prevent hazardous accumulations of food, since heavy spattering or spillovers left on the range can ignite. Use pans with handles that can be easily grasped and will remain cool.
 - **Keep all plastics away from the top burners.**
 - **Do not leave plastic items on the cooktop—they may melt if left too close to the vent.**
- **Do not leave any items on the cooktop.** The hot air from the vent may ignite flammable items and will increase pressure in closed containers, which may cause them to burst.
 - **To avoid the possibility of a burn, always be certain that the controls for all burners are at the OFF position and all grates are cool before attempting to remove them.**
 - **When flaming foods are under the hood, turn the fan OFF.** The fan, if operating, may spread the flames.
 - **If the range is located near a window,** do not hang long curtains that could blow over the top burners and create a fire hazard.
 - **When a pilot goes out (on models with standing pilots),** you will detect a faint odor of gas as your signal to relight the pilot. When relighting the pilot, make sure the burner controls are in the OFF position, and follow instructions in the Installation Instructions to relight.
 - **If you smell gas,** and you have already made sure the pilots are lit (on models with standing pilots), turn off the gas to the range and call a qualified service technician. Never use an open flame to locate a leak.

(continued next page)

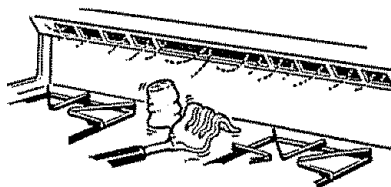

Vent appearance and location vary.

IMPORTANT SAFETY INSTRUCTIONS

Baking, Broiling and Roasting

- Do not use the oven for a storage area. Items stored in the oven can ignite.
- Stand away from the range when opening the door of a hot oven. The hot air and steam that escape can cause burns to hands, face and eyes.
- Keep the oven free from grease buildup.
- Place the oven shelves in the desired position while the oven is cool.
- Pulling out the shelf to the shelf-stop is a convenience in lifting heavy foods. It is also a precaution against burns from touching hot surfaces of the door or oven walls. The lowest position (R) is not designed to slide.
- Do not heat unopened food containers. Pressure could build up and the container could burst, causing an injury.
- Do not use aluminum foil anywhere in the oven except as described in this manual. Misuse could result in a fire hazard or damage to the range.
- Never use aluminum foil to line the oven bottom. Improper use of foil could start a fire.
- When using cooking or roasting bags in the oven, follow the manufacturer's directions.
- Use only glass cookware that is recommended for use in gas ovens.
- Always remove broiler pan from the oven or the broiler compartment as soon as you finish broiling. Grease left in the pan can catch on fire if oven is used without removing the grease from the broiler pan.
- When broiling, if meat is too close to the flame, the fat may ignite. Trim excess fat to prevent excessive flare-ups.
- Make sure the broiler pan is in place correctly to reduce the possibility of grease fires.
- If you should have a grease fire in the broiler pan, turn the oven off and keep the broiler compartment door closed to contain fire until it burns out.

Cleaning Your Range

- Clean only parts listed in this Use and Care Guide.
- Keep the range clean and free of accumulations of grease or spillovers, which may ignite.
- Be careful when you clean the cooktop because the area over the pilot will be hot (for standing pilot models).
- For continuous clean models, do not use oven cleaners on any of the continuous cleaning surfaces. Continuous cleaning surfaces can be identified by their rough surface finish.

SAVE THESE INSTRUCTIONS

FEATURES OF YOUR RANGE

NOTE: Not all models have all features. Appearance of features varies.

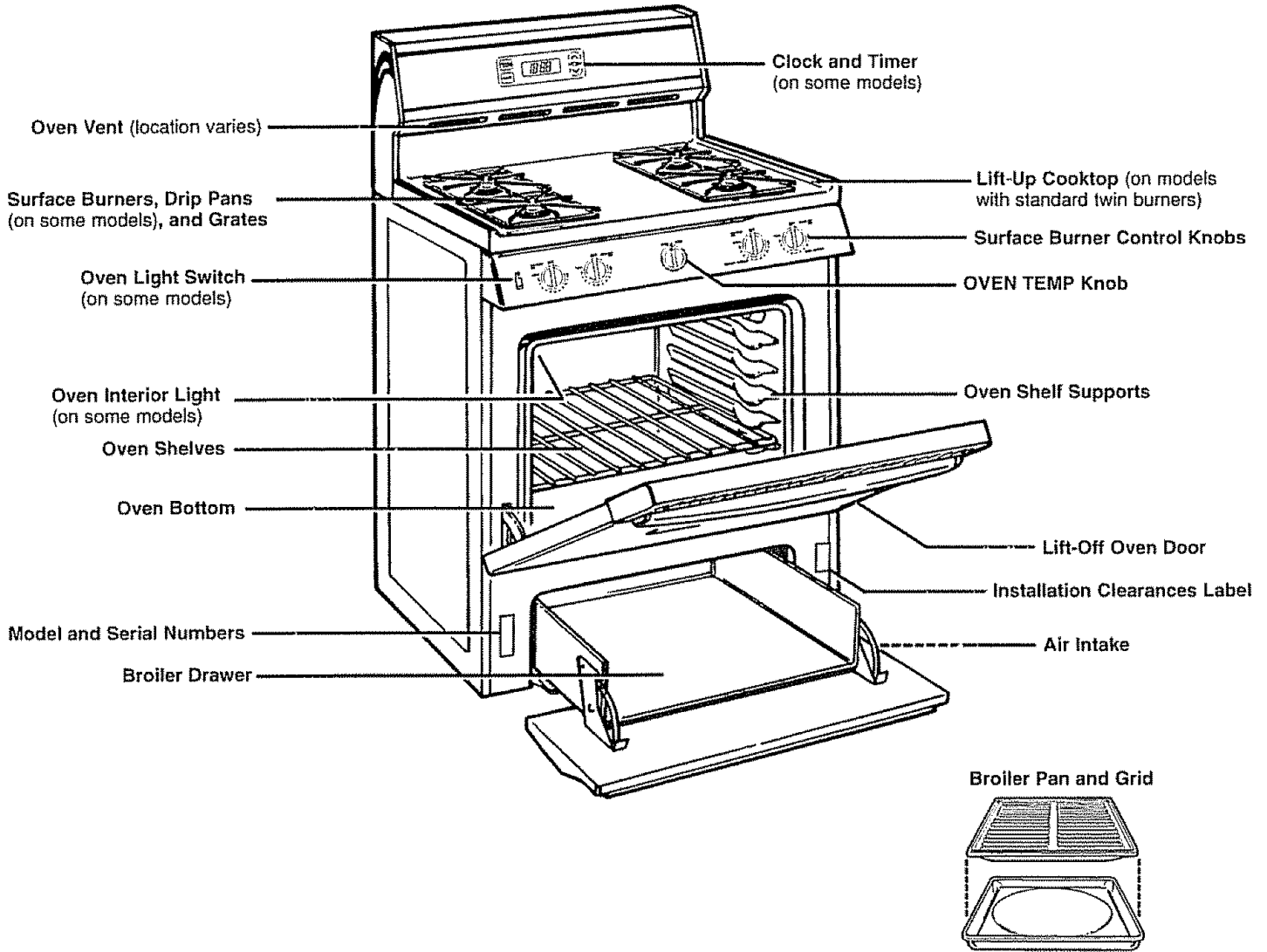

Your range is equipped with one of the two types of surface burners shown below.

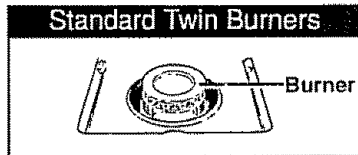
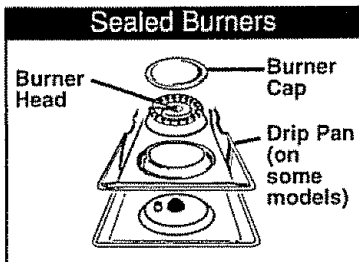

USING THE COOKTOP

Lighting Instructions for Standing Pilot Models

The surface burners on these ranges have standing pilots that must be lit initially. To light them:

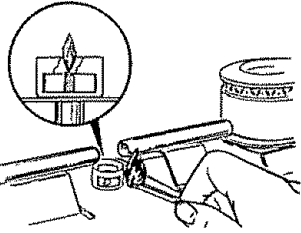

1. Be sure the surface burner control knobs are in the OFF position.
2. Remove the grates and lift the cooktop up (see the Lift-Up Cooktop section).
3. Locate the two pilot ports and light each of them with a match.

NOTE: If the pilot is too high or low, you can adjust it. See the Adjust the Surface Burner Pilots If Necessary section of the Installation Instructions.

4. Lower the cooktop. Your surface burners are now ready for use.
5. Observe the lighted burners. Compare the flames to pictures in the Before You Call for Service section. If any flame is unsatisfactory, call for service.

Lighting Instructions for Electronic Ignition Models

Your surface burners are lighted by electronic ignition, eliminating the need for standing pilot lights with constantly burning flames.

In case of a power failure, you can light the surface burners on your range with a match. Hold a lighted match to the burner, then turn the knob to the LITE position. **Use extreme caution when lighting burners this way.**

Surface burners in use when an electrical power failure occurs will continue to operate normally.

The electrode of the spark igniter is exposed. When one burner is turned to LITE, **all** the burners spark. Do not attempt to disassemble or clean around any burner while another burner is on. An electric shock may result, which could cause you to knock over hot cookware.

Surface Burner Controls

The knobs that turn the surface burners on and off are marked as to which burners they control.

The two knobs on the left control the left front and left rear burners. The two knobs on the right control the right front and right rear burners.

On ranges with sealed burners:

- The smaller burner (right rear position) will give the best simmer results. It offers precise cooking performance for delicate foods, such as sauces or foods which need to cook over low heat for a long time. It can be turned down to a very low simmer setting.
- The right front burner is higher powered than the others and will bring liquids to a boil quicker (natural gas installations only).
- On some models, the burners are all the same size and power.

Before Lighting a Burner

- If drip pans are supplied with your range, they should be used at all times.
- Make sure all grates on the range are in place before using a burner.

To Light a Surface Burner

Electronic Ignition Models:

Make sure all burners and caps are in place.

Push the control knob in and turn it to LITE. You will hear a little "clicking" noise—the sound of the electric spark igniting the burner.

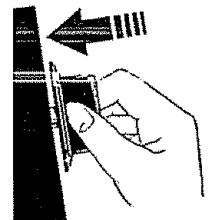

Standing Pilot Models:

Push the control knob in and turn it to HI position. The burner should light within a few seconds.

After the burner ignites, turn the knob to adjust the flame size.

Flame will be almost horizontal and will lift slightly away from the burner when the burner is first turned on. A blowing sound may be heard the first few seconds. This normal sound is due to improved injection of gas and air into the burner. Put a pan on the burner before lighting it, or adjust the flame to match pan size as soon as it lights, and the blowing sound will stop.

USING THE COOKTOP (continued)

After Lighting a Burner

- After the burner ignites, turn the knob to adjust the flame.
- Check to be sure the burner you turned on is the one you want to use.
- Do not operate a burner for an extended period of time without cookware on the grate. The finish on the grate may chip without cookware to absorb the heat.
- Be sure the burners and grates are cool before you place your hand, a pot holder, cleaning cloths or other materials on them.

How to Select Flame Size

Watch the flame, not the knob, as you reduce heat. When fast heating is desired, the flame size on a gas burner should match the cookware you are using.

FOR SAFE HANDLING OF COOKWARE NEVER LET THE FLAME EXTEND UP THE SIDES OF THE COOKWARE.

Any flame larger than the bottom of the cookware will not result in faster heating of the cookware and could be hazardous.

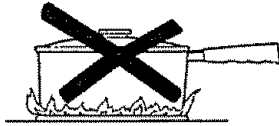

Top-of-Range Cookware

Aluminum: Medium-weight cookware is recommended because it heats quickly and evenly. Most foods brown evenly in an aluminum skillet. Use saucepans with tight-fitting lids when cooking with minimum amounts of water.

Cast-Iron: If heated slowly, most skillets will give satisfactory results.

Enamelware: Under some conditions, the enamel of some cookware may melt. Follow cookware manufacturer's recommendations for cooking methods.

Glass: There are two types of glass cookware—those for oven use only and those for top-of-range cooking (saucepans, coffee and teapots). Glass conducts heat very slowly.

Heatproof Glass Ceramic: Can be used for either surface or oven cooking. It conducts heat very slowly and cools very slowly. Check cookware manufacturer's directions to be sure it can be used on gas ranges.

Stainless Steel: This metal alone has poor heating properties and is usually combined with copper, aluminum or other metals for improved heat distribution. Combination metal skillets usually work satisfactorily if they are used with medium heat as the manufacturer recommends.

Wok This Way

(on models with sealed burners)

We recommend that you use a 14-inch or smaller flat-bottomed wok. Make sure the wok bottom sits flat on the grate. Only a flat-bottomed wok should be used. They are available at your local retail store.



Do not use a flat-bottomed wok on a support ring.

Placing the ring over the burner grate may cause the burner to work improperly, resulting in carbon monoxide levels above allowable standards. This could be dangerous to your health.

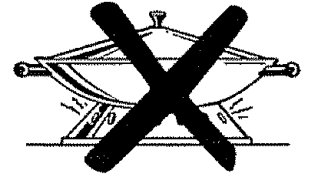

Stove Top Grills

(on models with sealed burners)

Do not use stove top grills on your sealed gas burners. If you use the stove top grill on the sealed gas burner it will cause incomplete combustion and can result in exposure to carbon monoxide levels above allowable standards. This can be hazardous to your health.

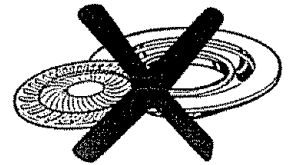

SETTING THE CONTROLS

Clock and Timer

(on some models)

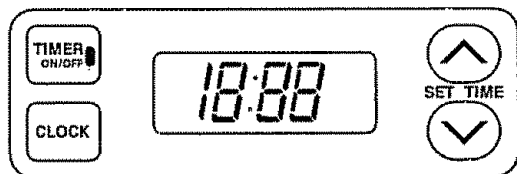

(appearance may vary)

Follow the directions below if your range has the clock and timer shown above. You have the choice of having the timer show the time counting down or the time of day. In either case, the timer will signal at the end of the timer period to alert you that the time is up.

To Set the Clock

NOTE: When you first plug in the range or after a power failure, the entire Clock/Timer display will light up.

1. Press the **CLOCK** pad.
2. Press and hold the ▲ or ▼ pad and the time of day will change 10 minutes at a time. To change the time by single minutes, give the pads short taps.
3. Press the **CLOCK** pad to start the clock.

To Set the Timer

1. Press the **TIMER ON/OFF** pad.
2. Use the ▲ or ▼ pads to set the timer. Short taps on the ▲ or ▼ pad change the timer's setting one minute at a time. Pressing and continuing to hold the ▲ pad increases the setting ten minutes at a time.
3. Once you have set your timer, press the **TIMER ON/OFF** pad to start timing. As the timer counts down a signal will indicate when one minute is left. After this signal, the display will count down in seconds. When time runs out, a final signal will sound. Press the **TIMER ON/OFF** pad to stop the signal.

To Change or Cancel the Timer Setting

When the timer is counting down, use the ▲ or ▼ pads to change the remaining time, or press the **TIMER ON/OFF** pad to stop the timer. The timer cannot be cancelled unless you have fully completed "set timer" instructions above.

To Display the Clock While the Timer Is Operating

Pressing the **CLOCK** pad while the timer is operating will not interfere with the timer's operation; the display will change to show the clock, but the timer will continue to count down and will still signal when time is up. Press the **TIMER ON/OFF** pad again to change the display back to show the timer.

USING THE OVEN

Before Using Your Oven

Be sure you understand how to set the control properly. Practice removing and replacing the shelves while the oven is cool. Read the information and tips on the following pages. Keep this guide handy where you can refer to it, especially during the first weeks of using your new range.

To avoid possible burns, place the shelves in the desired position before you turn the oven on.

Lighting Instructions for Standing Pilot Models

Some models have standing oven pilots that must be lit initially.

To light the oven pilot:

1. Be sure the OVEN TEMP knob is in the OFF position.
 2. Open the broiler drawer and remove the broiler pan and grid. This will make it easier for you to reach inside the broiler compartment.
 3. Find the oven pilot port at the back of the broiler compartment. The long tube, running from front to back, is the oven burner. The pilot port is at the back, about one inch below the burner.
 4. Using a long match or match holder, reach in and light the oven pilot.
- **To light the oven burner,** turn the OVEN TEMP knob to the desired temperature. The burner should light within 60 seconds.
 - **Proper flame configuration:** While using the oven burner, visually check the burner flame in the broiler compartment. If flame does not burn as described in the Installation section of this manual, adjust the flame following the directions on those pages.
 - **Power failure:** An electrical power failure will not affect a lighted standing oven pilot.

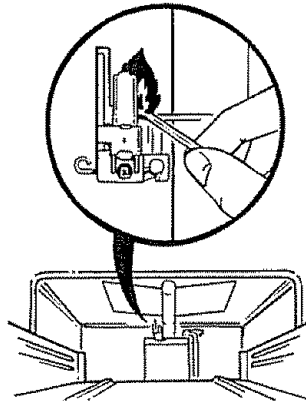

Lighting Instructions for Electric Ignition Models

The oven burner is lighted by electric ignition (on some models).

To light the burner, turn the OVEN TEMP knob to the desired temperature. The burner should ignite within 30–90 seconds.

After the oven reaches the selected temperature, the oven burner cycles—off completely, then on with a full flame—to keep the oven temperature controlled.

Power Outage

CAUTION: Do not make any attempt to operate the electric ignition oven during an electrical power failure. The oven or broiler cannot be lit during a power failure. Gas will not flow unless the glow bar is hot.

If the oven is in use when a power failure occurs, the oven burner shuts off and cannot be re-lit until power is restored.

(continued next page)

USING THE OVEN (continued)

OVEN TEMP Knob

The OVEN TEMP knob is located on the control panel on the front of the range. Simply turn the knob to the desired cooking temperatures.

It will normally take 30–90 seconds before the flame comes on. After the oven reaches the selected temperature, the oven burner cycles—off completely, then on with a full flame—to maintain the selected temperature.

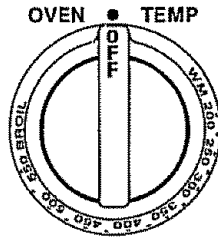

Oven Light

(on some models)

Use the switch on the control panel to turn the oven light on and off.

Oven Shelves

The shelves have stop-locks so, when placed correctly on the shelf supports (A through E), they will stop before coming completely out and will not tilt.

When placing and removing cookware, pull the shelf out to the bump on the shelf support.

To remove a shelf, pull it toward you, tilt the front end up and pull it out.

To replace, place the end of the shelf (stop-locks) on the support, tilt up the front and push the shelf in.

NOTE: The shelf is not designed to slide out at the special low (R) shelf position.

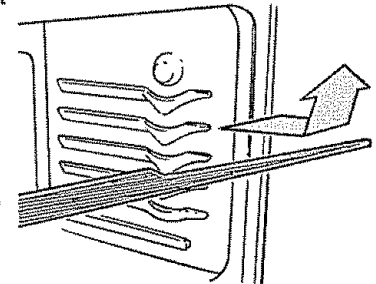
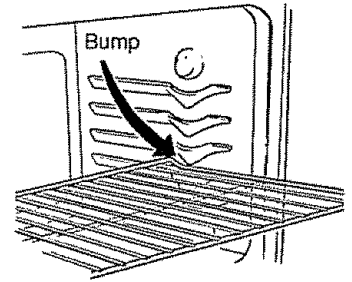

USING THE OVEN (continued)

Shelf Positions

The oven has five shelf supports for baking and roasting as shown in this illustration—A (bottom), B, C, D and E (top). It also has a special low shelf position (R) for roasting extra large items, such as a large turkey—the shelf is not designed to slide out at this position. The shelf positions for cooking are suggested in the Baking and Roasting sections.

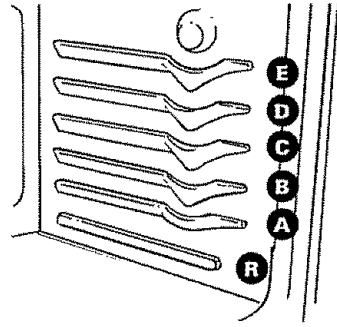

Oven Vents

The oven is vented through duct openings at the rear of the range. Do not block these openings when cooking in the oven—it is important that the flow of hot air from the oven and fresh air to the oven burners be uninterrupted.

- **Avoid touching the vent openings and nearby surfaces during oven or broiler operation. They may become hot.**
- **Do not leave plastic or flammable items on the cooktop—they may melt or ignite if left too close to the vent.**
- **Handles of pots and pans on the cooktop may become hot if left too close to the vent.**
- **Metal items will become very hot if they are left on the cooktop and could cause burns.**
- **Do not leave closed containers on the cooktop.** The pressure in closed containers may increase, which may cause them to burst.

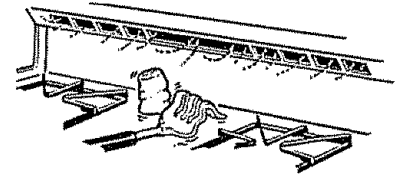

Vent appearance and location vary

Oven Moisture

As your oven heats up, the temperature change of the air in the oven may cause water droplets to form on the door glass. These droplets are harmless and will evaporate as the oven continues to heat up.

(continued next page)

USING THE OVEN (continued)

Baking

Your oven temperature is controlled very accurately using an oven control system. It is recommended that you operate the oven for a number of weeks to become familiar with your new oven's performance. If you think an adjustment is necessary, see the Adjust the Oven Thermostat section.

NOTE: Your oven is not designed for open-door cooking.

How to Set Your Range for Baking

To avoid possible burns, place the shelves in the correct position before you turn the oven on.

1. Close the oven door. Turn the OVEN TEMP knob to the desired temperature.
2. Check the food for doneness at the minimum time on the recipe. Cook longer if necessary.
3. Turn the OVEN TEMP knob to OFF and then remove food.

Oven Shelves

Arrange the oven shelf or shelves in the desired locations while the oven is cool. The correct shelf position depends on the kind of food and the browning desired.

As a general rule, place most foods in the middle of the oven, on either shelf position B or C. See the following chart for suggested shelf positions.

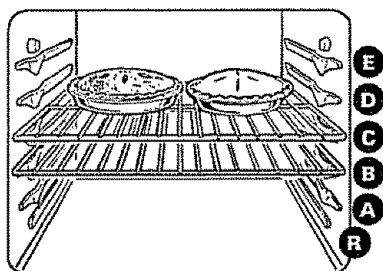

Type of Food	Shelf Position
Angel food cake	A
Biscuits or muffins	B or C
Cookies or cupcakes	B or C
Brownies	B or C
Layer cakes	B or C
Bundt or pound cakes	A or B
Pies or pie shells	B or C
Frozen pies	A (on cookie sheet)
Casseroles	B or C
Roasting	B or R

Preheating

Preheat the oven if the recipe calls for it. Preheat means bringing the oven up to the specified temperature before putting the food in the oven. To preheat, set the oven at the correct temperature—selecting a higher temperature does not shorten preheat time.

Preheating is necessary for good results when baking cakes, cookies, pastry and breads. For most casseroles and roasts, preheating is not necessary. For ovens without a preheat indicator light or tone, preheat 10 minutes. After the oven is preheated place the food in the oven as quickly as possible to prevent heat from escaping.

Baking Pans

Use the proper baking pan. The type of finish on the pan determines the amount of browning that will occur.

- Dark, rough or dull pans absorb heat resulting in a browner, crisper crust. Use this type for pies.
- Shiny, bright and smooth pans reflect heat, resulting in a lighter, more delicate browning. Cakes and cookies require this type of pan.
- Glass baking dishes also absorb heat. When baking in glass baking dishes, the temperature may need to be reduced by 25°F (13°C).
- If you are using dark non-stick pans, you may find that you need to reduce the oven temperature 25°F (13°C) to prevent over-browning.

Pan Placement

For even cooking and proper browning, there must be enough room for air circulation in the oven. Baking results will be better if baking pans are centered as much as possible rather than being placed to the front or to the back of the oven.

Pans should not touch each other or the walls of the oven. Allow 1- to 1½-inch (2.5- to 4-cm) space between pans as well as from the back of the oven, the door and the sides. If you need to use two shelves, stagger the pans so one is not directly above the other.

Baking

(continued)

Aluminum Foil

Never cover the oven bottom with aluminum foil.

Never entirely cover a shelf with aluminum foil.

This will disturb the heat circulation and result in poor baking. Aluminum foil may also be used to catch a spillover. To do so, place a small sheet of foil on a lower shelf several inches below the food.

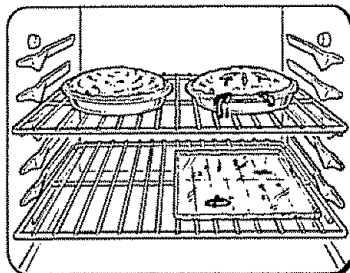

Don't Peek

Set the timer for the estimated cooking time and do not open the door to look at your food. Most recipes provide minimum and maximum baking times such as "bake 30–40 minutes."

DO NOT open the door to check until the minimum time. Opening the oven door frequently during cooking allows heat to escape and makes baking times longer. Your baking results may also be affected.

(continued next page)

Adjust the Oven Thermostat-- Do It Yourself!

You may feel that your new oven cooks differently than the one it replaced. We recommend that you use your new oven for a few weeks to become more familiar with it, following the times given in your recipes as a guide.

If you think your new oven is too hot or too cold, you can adjust the thermostat yourself. If you think it is too hot, adjust the thermostat to make it cooler. If you think it is too cool, adjust the thermostat to make it hotter.

We do not recommend the use of thermometers, such as those found in grocery stores, to check the temperature setting of your new oven. These thermometers may vary 20–40°F (11–22°C).

To Adjust the Thermostat:

Pull the oven TEMP knob off the range and look at the back side.

To make adjustment, loosen (approximately one turn), but do not completely remove, the two screws on the back of the knob. With the back of the knob facing you, hold the outer edge of the knob with one hand and turn the front of the knob with the other hand.

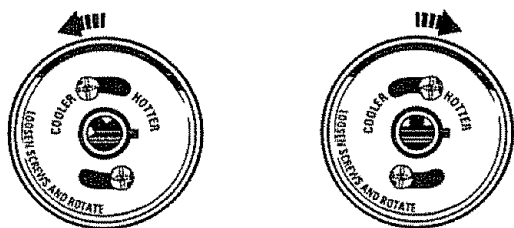

(appearance may vary)

To raise the oven temperature, move the top screw toward the right. You'll hear a click for each notch you move the knob. To lower the temperature, move the top screw toward the left. Each click will change the oven temperature approximately 10°F (6°C). [Range is plus or minus 60°F (33°C) from the arrow.]

We suggest that you make the adjustment one click from the original setting and check oven performance before making any additional adjustments.

After the adjustment is made, retighten screws so they are snug, but be careful not to overtighten. Reinstall knob on range and check performance.

Air Adjustment Shutter for Oven Burners

The air adjustment shutter for the bottom burner regulates the flow of air to the flames.

See the Installation Instructions of this manual for instructions for location and proper adjustment of the shutter.

The Type of Margarine Will Affect Baking Performance

Most recipes for baking have been developed using high fat products such as butter or margarine (80% fat). If you decrease the fat, the recipe may not give the same results as with a higher fat product.

Recipe failure can result if cakes, pies, pastries, cookies or candies are made with low fat spreads. The lower the fat content of a spread product, the more noticeable these differences become.

Federal standards require products labeled "margarine" to contain at least 80% fat by weight. Low fat spreads, on the other hand, contain less fat and more water. The high moisture content of these spreads affect the texture and flavor of baked goods. For best results with your old favorite recipes, use margarine, butter or stick spreads containing at least 70% vegetable oil.

Roasting

If your model has a latch, do not lock the oven door during roasting. The latch is used for self-cleaning only.

Roasting is cooking by dry heat. Tender meat or poultry can be roasted uncovered in your oven. Roasting temperatures, which should be low and steady, keep spattering to a minimum.

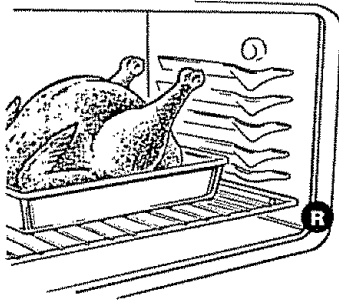

The oven has a special low shelf position (R) just above the oven bottom. Use it when extra cooking space is needed, for example, when roasting a large turkey. The shelf is not designed to slide out at this position.

Roasting is really a baking procedure used for meats. Therefore, the oven controls are set for Baking. (You may hear a slight clicking sound indicating the oven is working properly.)

Most meats continue to cook slightly while standing after being removed from the oven. Recommended standing time for roasts is 10 to 20 minutes. This allows the roasts to firm up and makes them easier to carve. The internal temperature will rise about 5° to 10°F (3° to 6°C). If you wish to compensate for the temperature rise, remove the roast from the oven when its internal temperature is 5° to 10°F (3° to 6°C) less than the temperature shown in the Roasting Guide.

Remember that food will continue to cook in the hot oven and therefore should be removed when the desired internal temperature has been reached.

1. Position oven shelf at position B for small size roast (3 to 5 lbs. [1.3 to 2.3 kg]) and at position R for larger roasts.

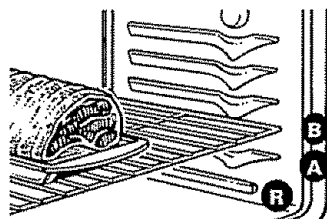

2. Check the weight of the meat. Place the meat fat-side-up or the poultry breast-side-up on roasting grid in a shallow pan. The melting fat will baste the meat. Select a pan as close to the size of the meat as possible. (The broiler pan with grid is a good pan for this.)

3. Turn the OVEN TEMP knob to the desired temperature (you may hear a slight clicking sound, indicating the oven is working properly). See the Roasting Guide for temperatures and approximate cooking times.
4. When roasting is finished, turn the OVEN TEMP knob to OFF and then remove the food from the oven.

Dual Shelf Cooking

This allows more than one food to be cooked at the same time. For example: While roasting a 20-lb. (10 kg) turkey on shelf position R, a second shelf (if so equipped) may be added on position D so that an additional food such as scalloped potatoes can be cooked at the same time. Foods cooked with the turkey should be added toward the end of the time allowed for the turkey. For example, potatoes which cook for 1 hour should be added to the oven 1 hour before the end of cooking time for the turkey.

Use of Aluminum Foil

You can use aluminum foil to line the broiler pan. This makes clean-up easier when using the pan for marinating, cooking with fruits, cooking heavily cured meats or basting food during cooking. Press the foil tightly around the inside of the pan.

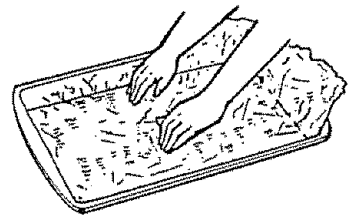

Never cover the oven bottom with aluminum foil.

Never entirely cover a shelf with aluminum foil. This will disturb the heat circulation and result in poor baking. Aluminum foil may also be used to catch a spillover. To do so, place a small sheet of foil on a lower shelf several inches below the food.

Frozen Roasts

Frozen roasts of beef, pork, lamb, etc., can be started without thawing, but allow 15 to 25 minutes per pound (450 grams) additional time (15 minutes per pound for roasts under 5 pounds [2.3 kg], more time for larger roasts).

Make sure poultry is thawed before roasting. Unthawed poultry often does not cook evenly. Some commercial frozen poultry can be cooked successfully without thawing. Follow the directions given on the package label.

(continued next page)

USING THE OVEN (continued)

Roasting Guide

Type	Oven Temperature	Doneness	Approximate Roasting Time in Minutes per Pound		Internal Temperature
Meat			3 to 5 lbs. (1.4 to 2.3 kg)	6 to 8 lbs. (2.7 to 3.6 kg)	
Tender cuts; rib, high quality sirloin tip, rump or top round*	325°F (163°C)	Rare: Medium: Well Done:	24–35 35–39 39–45	18–25 25–31 31–33	140–150°F (60–66°C)† 150–160°F (66–71°C) 170–185°F (77–85°C)
Lamb leg or bone-in shoulder*	325°F (163°C)	Rare: Medium: Well Done:	21–25 25–30 30–35	20–23 24–28 28–33	140–150°F (60–66°C)† 150–160°F (66–71°C) 170–185°F (77–85°C)
Veal shoulder, leg or loin*	325°F (163°C)	Well Done:	35–45	30–40	170–180°F (77–82°C)
Pork loin, rib or shoulder*	325°F (163°C)	Well Done:	35–45	30–40	170–180°F (77–82°C)
Ham, precooked	325°F (163°C)	To Warm:	18–23 minutes per pound (450 grams) any weight		115–125°F (46–52°C)
Poultry			3 to 5 lbs. (1.4 to 2.3 kg)	Over 5 lbs. (2.3 kg)	
Chicken or Duck Chicken pieces	325°F (163°C) 350°F (177°C)	Well Done: Well Done:	35–40 35–40	30–35	185–190°F (85–88°C) 185–190°F (85–88°C)
Turkey	325°F (163°C)	Well Done:	10 to 15 lbs. (4.5 to 6.8 kg) 16–22	Over 15 lbs. (6.8 kg) 12–19	In thigh: 185–190°F (85–88°C)

* For boneless rolled roasts over 6" (15 cm) thick, add 5 to 10 minutes per pound (450 grams) to times given above.

† The U.S. Department of Agriculture says, "Rare beef is popular, but you should know that cooking it to only 140°F (60°C) means some food poisoning organisms may survive." (Source: *Safe Food Book. Your Kitchen Guide.* USDA Rev. June 1985.)

Broiling

Broiling is cooking food by direct heat from above the food. Your range has a convenient drawer below the oven for broiling. It also has a specially designed broiler pan and grid that allows the dripping fat to drain away from the high heat of the gas flame.

It is recommended that meat be cooked to at least an INTERNAL temperature of 160°F (71°C) and poultry to at least an INTERNAL temperature of 180°F (82°C). Cooking to these temperatures usually protects against foodborne illness.

Distance from the heat source may be changed by positioning the broiler pan and grid on one of the three shelf positions in the broiler drawer—A (bottom of broiler drawer), B (middle) and C (top).

Most fish and tender cuts of meat can be broiled. Follow these directions to keep spattering and smoking to a minimum.

The oven door and broiler drawer door must be closed during broiling.

Turn most foods once during cooking (the exception is thin fillets of fish; oil one side, place that side down on the broiler grid and cook without turning until done). Time the food for about one-half the total cooking time, turn the food, then continue to cook to the preferred doneness.

How to Broil

1. The broiler drawer does not need to be preheated for broiling.
2. If the meat has fat or gristle around the edge, cut vertical slashes through both about 2" (5 cm) apart, but do not cut into meat. If desired the fat may be trimmed, leaving a layer about 1/8" (3 mm) thick.
3. Arrange the food on the grid and position the broiler pan on the appropriate shelf in the broiler drawer. Placing the food closer to flame sears the exterior and increases the surface browning of food, but also increases spattering and the possibility of fats and meat juices igniting.
4. Close the broiler drawer and turn the OVEN TEMP knob to BROIL.
5. When broiling is finished, turn the OVEN TEMP knob to OFF. Remove the broiler pan from the broiler drawer and serve the food immediately. Do not leave a soiled broiler pan and grid inside the range.

Use of Aluminum Foil

You can use aluminum foil to line your broiler pan and broiler grid. However, you must mold the foil tightly to the grid and cut slits in it just like the grid.

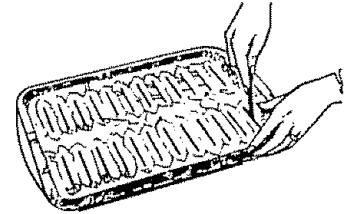

Cut slits in the foil just like the grid.

Without the slits, the foil will prevent fat and meat juices from draining to the broiler pan. The juices could become hot enough to catch on fire. If you do not cut the slits, you are frying, not broiling.

Never cover the oven bottom with aluminum foil.

Never entirely cover a shelf with aluminum foil.

This will disturb the heat circulation and result in poor baking. Aluminum foil may also be used to catch a spillover. To do so, place a small sheet of foil on a lower shelf several inches below the food.

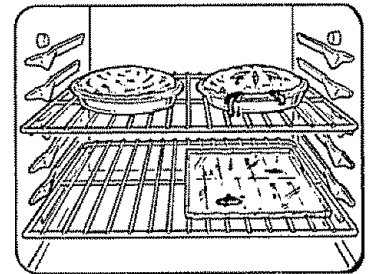

(continued next page)

USING THE OVEN (continued)

Broiling Guide

The oven door and broiler drawer must be *closed* during broiling.

- Always use the broiler pan and grid that comes with your range. It is designed to minimize smoking and spattering by trapping juices in the shielded lower part of the pan.
- For steaks and chops, slash fat evenly around the outside edges of the meat. To slash, cut crosswise through the outer fat surface just to the edge of the meat. Use tongs to turn the meat over to prevent piercing the meat and losing juices.

- If desired, marinate meats or chicken before broiling. Or brush with barbecue sauce last 5 to 10 minutes only.
- When arranging the food on the pan, do not let fatty edges hang over the sides because dripping fat could soil the oven.
- The broiler drawer does not need to be preheated. However, for very thin foods, or to increase browning, preheat if desired.
- Frozen steaks can be broiled by positioning the broiler pan and grid at next lowest shelf position and increasing cooking time given in this guide 1½ times per side.

The size, weight, thickness, starting temperature and your preference of doneness will affect broiling times. This guide is based on meats at refrigerator temperature

†The U.S. Department of Agriculture says "Rare beef is popular, but you should know that cooking it to only 140°F (60°C) means some food poisoning organisms may survive." (Source: *Safe Food Book, Your Kitchen Guide*, USDA Rev. June 1985.)

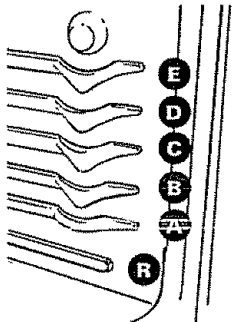

The oven has 5 shelf positions.

Food	Quantity and/or Thickness	Shelf* Position	1st Side Minutes	2nd Side Minutes	Comments
Bacon	½ lb (227 g) (about 8 thin slices)	B	4	3	Arrange in single layer
Ground Beef Well Done	1 lb (450 g) (4 patties) ½"–¾" (13–19 mm) thick	B	10–11	4–5	Space evenly Up to 8 patties take about same time.
Beef Steaks					
Rare†	1" (2.5 cm) thick	C	9	7	Steaks less than 1" (2.5 cm) thick cook through before browning Pan frying is recommended
Medium	1–1½ lbs [450 g–680 g])	C	12	5–6	
Well Done		B	13	8–9	
Rare†	1½" (3.8 cm) thick	C	10	6–7	Slash fat
Medium	2–2½ lbs [907 g–1 13 kg])	C	12–15	10–12	
Well Done		B	25	16–18	
Chicken	1 whole (2–2½ lbs [907 g–1 13 kg]), split lengthwise Bone-in, 4 bone-in breasts	A	30–35	15	Reduce times about 5 to 10 minutes per side for cut-up chicken Brush each side with melted butter Broil with skin side down first.
		A	25–30	10–15	
Bakery Products					
Bread (Toast) or Toaster Pastries	2–4 slices	C	2–3	1/2–1	Space evenly Place English muffins cut-side-up and brush with butter, if desired.
English Muffins	1 pkg (2) 2, split	C	3–5		
Lobster Tails	2–4 (6–8 oz [170 g–227 g] ea)	A	13–16	Do not turn over	Cut through back of shell and spread open Brush with melted butter before broiling and after half of broiling time.
Fish	1 lb (450 g) fillets ¼"–½" (6–13 mm) thick	C	5	5	Handle and turn very carefully Brush with lemon butter before and during broiling, if desired Preheat broiler to increase browning.
Ham Slices	1" (2.5 cm) thick	C	8	8	Increase times 5 to 10 minutes per side for 1½" (3.8 cm) thick or home cured.
Precooked	1/2" (13 mm) thick	D	6	6	
Pork Chops	2 (1/2" [13 mm] thick)	B	10	4–5	Slash fat.
Well Done	2 (1" [2.5 cm] thick), about 1 lb. (450 g)	B	13	9–12	
Lamb Chops					
Medium	2 (1" [2.5 cm] thick), about 10–12 oz. (284–340 g)	B	8	4–7	Slash fat
Well Done		B	10	10	
Medium	2 (1½" [3.8 cm] thick), about 1 lb. (450 g)	B	10	4–6	
Well Done		B	17	12–14	
Wieners, similar precooked sausages, bratwurst	1 lb. (450 g) pkg. (10)	C	6	1–2	If desired, split sausages in half length-wise; cut into 5–6" (13–15 cm) pieces.

*See illustration for description of shelf positions.

CARE AND CLEANING

Proper care and cleaning are important so your range will give you efficient and satisfactory service. Follow these directions carefully in caring for it to help assure safe and proper maintenance.

BE SURE ELECTRICAL POWER IS DISCONNECTED BEFORE CLEANING ANY PART OF YOUR RANGE.

Sealed Burner Assemblies

(on some models)

CAUTION: DO NOT OPERATE THE BURNER WITHOUT ALL BURNER PARTS AND DRIP PANS (IF SO EQUIPPED) IN PLACE.

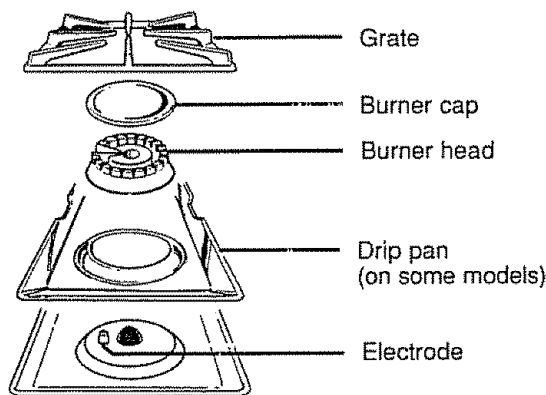

Turn all the controls off before removing burner parts and drip pans (if so equipped).

The burner grates, caps, heads and drip pans (if so equipped) can be lifted off, making them easy to clean.

The electrode of the spark igniter is exposed when the burner head is removed. When one burner is turned to LITE, all the burners spark. Do not attempt to disassemble or clean around any burner while another burner is on. An electric shock may result, which could cause you to knock over hot cookware.

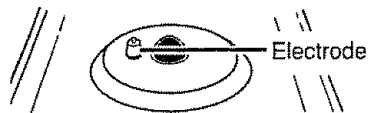

Burner Heads

(on sealed burners only)

NOTE: Before removing the burner heads and caps, remember their size and location. Replace them in the same location after cleaning.

For proper ignition, make sure the small hole in the section that fits over the electrode is kept open. A sewing needle or wire twist-tie works well to unclog it.

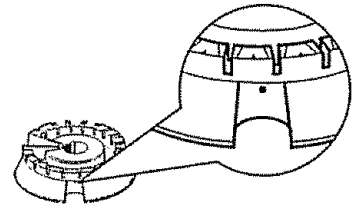

The slits in the burner heads of your range must be kept clean at all times for an even, unhampered flame.

You should clean the surface burners routinely, especially after bad spillovers, which could clog these openings.

To remove burned-on food, soak the burner heads in a solution of mild liquid detergent and hot water for 20–30 minutes. For more stubborn stains, use a toothbrush.

Before putting the burner head back, shake out excess water and then dry it thoroughly by setting it in a warm oven for 30 minutes.

Replace the burner heads and caps. Make sure that the heads and caps are replaced in the correct location. There is one small, 2 medium and one large cap.

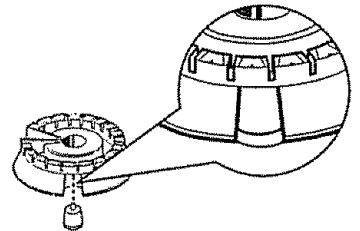

NOTE: On some models the burner heads and caps are all the same size and can be used in any of the 4 needed locations.

After cleaning, make sure the slot in the burner head is positioned over the electrode.

NOTE: Do not use steel wool or scouring powders to clean the burners.

(continued next page)

CARE AND CLEANING (continued)

Burner Caps

(on sealed burners only)

Lift off when cool. Wash burner caps in hot, soapy water and rinse with clean water. You may scour with a plastic scouring pad to remove burned-on food particles.

Dry them in a warm oven or with a cloth—don't reassemble them wet. Replace the burner caps.

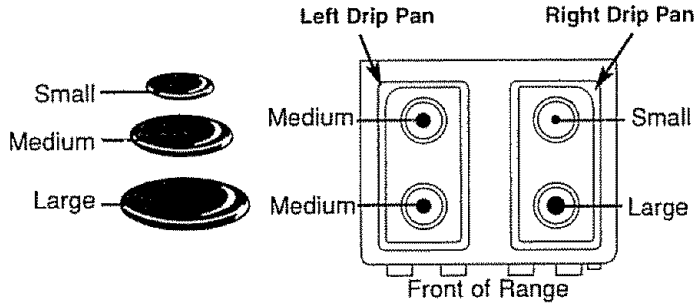

Make sure that caps are replaced on the correct size burner. There is one small, 2 medium and one large cap. Sizes are marked on the bottom of medium and large caps.

NOTE: On some models the caps are all the same size and can be used in any of the 4 needed locations.

Burner Grates

Lift out when cool.

The grates should be washed regularly and, of course, after



spillovers. Wash them in hot, soapy water and rinse with clean water. After cleaning, dry them thoroughly by putting them in a warm oven for a few minutes. Don't put the grates back on the range while they are wet. When replacing the grates, be sure they're positioned securely over the burners.

To prevent rusting on cast iron grates, apply a light coating of cooking oil on the bottom of the grates.

To get rid of burned-on food, place the grates in a covered container. Add ¼ cup ammonia and let them soak several hours or overnight. Wash, rinse well and dry.

Although they're durable, the grates will gradually lose their shine, regardless of the best care you can give them. This is due to their continual exposure to high temperatures.

Do not operate a burner for an extended period of time without cookware on the grate. The finish on the grate may chip without cookware to absorb the heat.

CAUTION: Do not clean the grates in a self-cleaning oven.

Drip Pans

(on some models)

Remove the grates and lift out the drip pans. The drip pans can be cleaned in a dishwasher or by hand.

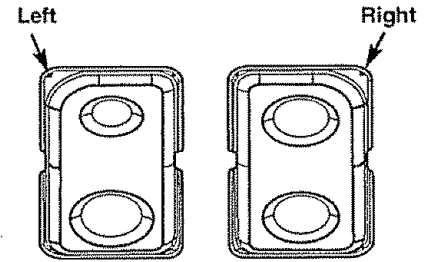

To get rid of burned-on food, place the drip pans in a covered container. Add ¼ cup ammonia and let them soak several hours. Wash, rinse well and dry.

When replacing the drip pans, make sure they are in the correct position.

CAUTION: Do not clean the drip pans in a self-cleaning oven.

Cooktop Surface

To avoid damaging the porcelain enamel surface of the cooktop and to prevent it from becoming dull, clean up spills right away. Foods with a lot of acid (tomatoes, sauerkraut, fruit juices, etc.) or foods with high sugar content could cause a dull spot if allowed to sit.

When the surface has cooled, wash and rinse. For other spills such as fat splatterings, etc., wash with soap and water once the surface has cooled. Then rinse and polish with a dry cloth.

Be careful when you clean the cooktop because the area over the pilot will be hot (on models with standing pilots).

Do not store flammable materials in an oven or near the cooktop. Do not store or use combustible materials, gasoline or other flammable vapors and liquids in the vicinity of this or any other appliance.

CARE AND CLEANING

Standard Twin Burners

(on some models)

CAUTION: DO NOT OPERATE THE BURNER WITHOUT ALL BURNER PARTS AND DRIP PANS (if so equipped) IN PLACE.

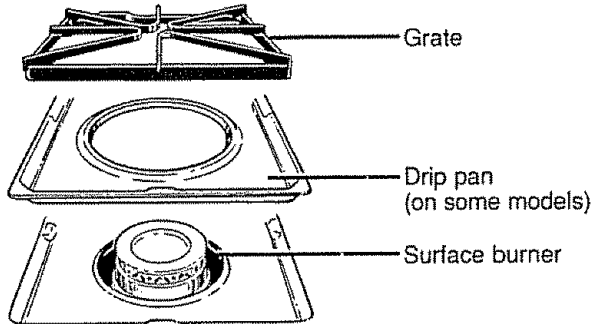

On models with standard twin burners, the cooktop lifts up for easy access.

Turn all the controls off before removing burner parts and drip pans (if so equipped).

The burner grates and drip pans (if so equipped) can be lifted off, making them easy to clean.

The holes in the surface burners of your range must be kept clean at all times for proper ignition and an even, unhampered flame.

You should clean the surface burners routinely, especially after bad spillovers, which could clog these holes. Wipe off the surface burners. If heavy spillover occurs, remove the surface burners from the range. Burners lift out for cleaning. Lift up the cooktop and then lift out the surface burners.

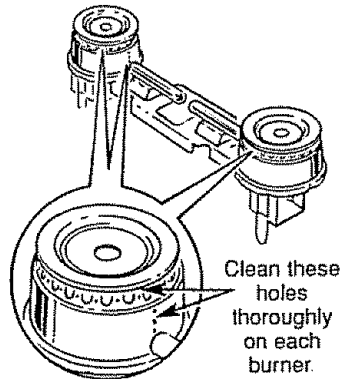

To remove burned-on food, soak the surface burner in a solution of mild liquid detergent and water. Soak the surface burner for 20 to 30 minutes. For more stubborn stains use a cleanser like Soft Scrub® brand or Bon Ami® brand. Rinse well to remove any traces of the cleanser that might clog the burner openings. Do not use steel wool because it will clog the surface burner openings and scratch the surface burners. If the holes become clogged, clean them with a sewing needle or twist-tie.

Before putting the surface burner back, shake out excess water and then dry it thoroughly by setting it in a warm oven for 30 minutes. Then place it back in the range, making sure it is properly seated and level.

Check the flame pattern of each burner. If the flames are "jumpy" (not steady), clean the holes again with a sewing needle or twist-tie.

Lift-Up Cooktop

(on models with standard twin burners)

Clean the area under the cooktop often. Built-up soil, especially grease, may catch on fire.

To make cleaning easier, the cooktop may be lifted up.

To raise the cooktop:

1. Be sure the burners are turned off.
2. Remove the grates.
3. Grasp the two front burner wells and lift up.

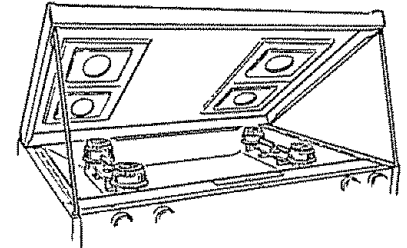

Some models have dual support rods that will hold the cooktop up while you clean underneath it.

After cleaning under the cooktop with hot, soapy water and a clean cloth, lower the cooktop. Be careful not to pinch your fingers. Lower cooktop gently to avoid blowing out pilot flames (on models with standing pilots).

NOTE: Do not lift the cooktop on sealed burner models. Lifting the cooktop can lead to damage and improper operation of the range.

(continued next page)

CARE AND CLEANING (continued)

Oven Air Vents

Never block the vents (air openings) of the range. They provide the air inlet and outlet that are necessary for the range to operate properly with correct combustion. Air openings are located at the rear of the cooktop, at the top and bottom of the oven door, and at the bottom of the range, under the broiler drawer.

Broiler Pan and Grid

After broiling, remove the broiler pan from the broiler compartment. Remove the grid from the pan. Carefully pour out grease from the pan into a proper container. Wash and rinse the broiler pan and grid in hot water with a soap-filled or plastic scouring pad.

If food has burned on, sprinkle the grid with detergent while hot and cover with wet paper towels or a dishcloth. Soaking the pan will remove burned-on foods.

The broiler pan and grid may be cleaned with a commercial oven cleaner.

Both the broiler pan and grid can also be cleaned in a dishwasher.

Do not store a soiled broiler pan and grid anywhere in the range.

CAUTION: Do not clean the broiler pan or grid in a self-cleaning oven.

Oven Shelves



Clean the shelves with an abrasive cleanser or scouring pad. After cleaning, rinse the shelves with clean water and dry with a clean cloth.

Lower Control Panel (Front Manifold Panel) and Knobs

It's a good idea to wipe the control panel after each use of the oven. Use a damp cloth to clean or rinse. For cleaning, use mild soap and water or a 50/50 solution of vinegar and water. For rinsing, use clean water. Polish dry with a soft cloth.

Do not use abrasive cleansers, strong liquid cleaners, plastic scouring pads or oven cleaners on the control panel—they will damage the finish. Do not bend control knobs by pulling them up or down or by hanging a towel or other such loads on them. This can damage the gas valve shaft.

The control knobs may be removed for easier cleaning. To remove knob, pull it straight off the stem. If knob is difficult to remove, place a towel or dishcloth between the knob and control panel and pull gently. Wash the knobs in soap and water, or a vinegar and hot water solution.

Metal parts can be cleaned with soap and water. Do not use steel wool, abrasives, ammonia, acids or commercial oven cleaners. Dry with a soft cloth.

Oven Light Bulb

(on some models)

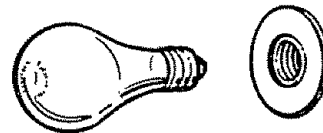

CAUTION: Disconnect electrical power to the oven at the main circuit breaker or fuse box before attempting to replace the oven light bulb. Do not touch a hot light bulb with wet hands or a wet cloth. Wait until the bulb has cooled and use a dry cloth.

The light bulb is located in the upper left corner of the oven. Replace the bulb with a 40 watt appliance bulb only.

Lift-Off Oven Door

The oven door is removable but it is heavy. You may need help removing and replacing the door.

To remove the door, open it a few inches to the special stop position that will hold the door open. Grasp firmly on each side and lift the door straight up and off the hinges.

NOTE: Be careful not to place hands between the hinge and the oven door frame as the hinge could snap back and pinch fingers.

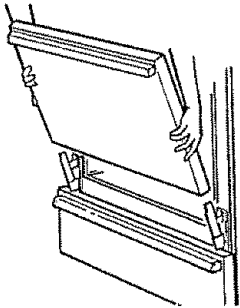

To replace the door, make sure the hinges are in the special stop position. Position the slots in the bottom of the door squarely over the hinges. Then lower the door slowly and evenly over both hinges at the same time. If hinges snap back against the oven frame, pull them back out.

To Clean the Door:

Do not allow excess water to run into any holes or slots in the door.

Inside of door:

- Allow to cool before cleaning. For light soil, wipe frequently with mild soap and water (especially after cooking meat). This will prolong the time between major cleanings. Rinse thoroughly.

NOTE: Soap left on the oven door causes additional stains when the oven is reheated.

- For heavy soil, you can use an oven cleaner (to avoid damage to continuous clean oven surfaces, remove the door of these models before spraying) and follow label instructions. Rinse well.

See "Cautions about using spray-on oven cleaners" below.

Outside of door:

- Use soap and water to thoroughly clean the top, sides and front of the oven door. Rinse well. You may also use a glass cleaner to clean the glass on the outside of the door.
- Spillage of marinades, fruit juices, tomato sauces and basting materials containing acids may cause discoloration and should be wiped up immediately. When surface is cool, clean and rinse.
- **Do not use oven cleaners, cleansing powders or harsh abrasives such as steel wool pads on the outside of the door.**

Porcelain Oven Interior

(on all models except continuous cleaning models)

With proper care, the porcelain enamel interior will retain its attractive finish for many years.

Soap and water will normally do the job. Heavy spattering or spillovers may require cleaning with a mild abrasive cleanser. Soap-filled steel wool pads may also be used. Do not allow food spills with a high sugar or acid content (such as tomatoes, sauerkraut, fruit juices or pie filling) to remain on the surface. They may cause dull spots even after cleaning.

Household ammonia may make the cleaning job easier. Place ½ cup (125 ml) ammonia in a shallow glass pan and leave in a cold oven overnight. The ammonia fumes will help loosen the burned-on grease and food.

When necessary, you may use a commercial oven cleaner. Follow the package directions.

Cautions about using spray-on oven cleaners:

- Be careful where the oven cleaner is sprayed.
- Do not spray oven cleaner on the electrical controls and switches (on some models) because it could cause a short circuit and result in sparking or fire.
- Do not allow a film from the cleaner to remain on the temperature sensing bulb—it could cause the oven to heat improperly. (The bulb is located at the rear of the oven.) Carefully wipe the bulb clean after each oven cleaning, being careful not to move the bulb as a change in its position could affect how the oven bakes.
- Do not spray any oven cleaner on the outside oven door, handles or any exterior surface of the oven, cabinets or painted surfaces. The cleaner can damage these surfaces.

(continued next page)

CARE AND CLEANING (continued)

Oven Bottom

The oven bottom has a porcelain enamel finish.

To make cleaning easier, protect the oven bottom from excessive spillovers by placing a cookie sheet on the shelf below the shelf you are cooking on. You can use aluminum foil if you do not cover the whole shelf. This is particularly important when baking a fruit pie or other foods with a high acid content. Hot fruit fillings or other foods that are highly acidic (such as tomatoes, sauerkraut and sauces with vinegar or lemon juice) may cause pitting and damage to the porcelain enamel surface and should be wiped up immediately.

If a spillover does occur on the oven bottom, allow the oven to cool first. Remove the oven bottom for easier clean-up and to prevent damage to the continuous cleaning oven coating (on some models).

Frequent wipings with mild soap and water (particularly after cooking meat) will prolong the time between major cleanings. Rinse thoroughly. Soap left on the oven bottom can cause stains.

For heavy soil, use an abrasive cleaner or a soap-filled steel wool pad. A commercial oven cleaner may also be used, following the package directions.

Removable Broiler Drawer

To remove:

1. When the broiler is cool, remove the grid and pan.
2. Pull the broiler drawer out until it stops, then push it back in about one inch.
3. Grasp the handle, lift and pull the broiler drawer out. Clean the broiler drawer with hot, soapy water.

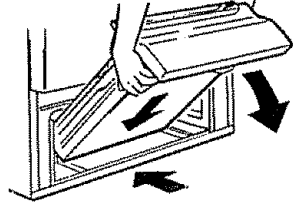

To replace:

Hold the broiler drawer in the raised position as you slide it partway into the range. Then lower the drawer and push it completely closed.

Special Care of the Continuous Cleaning Oven Interior

(on some models)

The special coating is a porous ceramic material, which is dark in color and feels slightly rough to the touch.

The continuous cleaning oven cleans itself while cooking. The oven walls are finished with a special coating that cannot be cleaned in the usual manner with soap, detergents, steel wool pads, commercial oven cleaners, coarse abrasive pads or coarse brushes. Use of such cleansers and/or the use of oven sprays will cause permanent damage.

If magnified, the surface would appear as peaks, valleys and sub-surface "tunnels." This rough finish tends to prevent grease spatters from forming little beads or droplets that run down the side walls of a hard-surface oven liner, leaving unsightly streaks that require hand cleaning. Instead, when spatter hits the porous finish, it is dispersed and partially absorbed. This spreading action increases the exposure of oven soil to heated air and makes it somewhat less noticeable.

Soil may not disappear completely and at some time after extended usage, stains may appear that cannot be removed.

The special coating works best on small amounts of spatter. It does not work well with larger spills, especially sugars, egg or dairy mixtures. The oven bottom does not have the continuous cleaning oven coating and can be removed and cleaned with a commercial oven cleaner.

This special coating is not used on the oven shelves, oven bottom or the inside of the oven door. Remove these to clean with a commercial oven cleaner to prevent damaging the continuous cleaning oven coating.

Make sure the oven bottom is in place before you turn the oven on for any reason.

Use care in removing and replacing the oven bottom and shelves and in placing and removing dishes and food to avoid scratching, rubbing or otherwise damaging the porous finish on the oven walls.

To Clean the Continuous Cleaning Oven:

1. Let range parts cool before handling. We recommend rubber gloves be worn when cleaning.
2. Remove shelves and cookware.
3. Soil visibility may be reduced by operating the oven at 400°F (204°C). Close the door and turn OVEN TEMP knob to 400°F (204°C). Time for at least four hours. Repeated cycles may be necessary before improvement in appearance is apparent.

Remember: During the operation of the oven, the door and other range surfaces will get hot enough to cause burns. Do not touch. Let the range cool before replacing the oven shelves.

4. If a spillover or heavy soiling occurs on the porous surface, as soon as the oven has cooled, remove as much of the soil as possible using a small amount of water and a stiff-bristle nylon brush. Use water sparingly and change it frequently, keeping it as clean as possible, and be sure to blot it up with paper towels, cloths or sponges. Do not rub or scrub with paper towels, cloths or sponges, since they will leave unsightly lint on the oven finish. If water leaves a white ring on the finish as it dries, apply water again and blot it with a clean sponge, starting at the edge of the ring and working toward the center.

The oven bottom has a porcelain enamel finish.

The oven bottom comes out for cleaning away from the continuous cleaning oven.

The inside of the oven door has a porcelain enamel finish. The oven door lifts off for cleaning away from the continuous cleaning oven. For instructions on how to clean the inside of the oven door refer to the Lift-Off Oven Door section.

Do not use soap, detergent, steel wool pads, commercial oven cleaners, silicone oven sprays, coarse pads or coarse brushes on the porous surface. These products will spot, clog and damage the porous surface and reduce its ability to work.

Do not scrape the porous surface with a knife or spatula—they could permanently damage the finish.

INSTALLATION INSTRUCTIONS

FOR YOUR SAFETY

If you smell gas:

1. Open windows.
2. Don't touch electrical switches.
3. Extinguish any open flame.
4. Immediately call your gas supplier.

FOR YOUR SAFETY

Do not store or use combustible materials, gasoline or other flammable vapors and liquids in the vicinity of this or any other appliance.

BEFORE YOU BEGIN

Read these instructions completely and carefully.

IMPORTANT: Save these instructions for the local electrical inspector's use.

INSTALLER: Leave these instructions with the appliance after installation is completed.

CONSUMER: Keep this Use and Care Manual and the Installation Instructions for future use.

This appliance must be properly grounded.

WARNING

Improper installation, adjustment, alteration, service or maintenance can cause injury or property damage. Refer to this manual. For assistance or additional information, consult a qualified installer, service agency, manufacturer (dealer) or the gas supplier.

Never reuse old flexible connectors. The use of old flexible connectors can cause gas leaks and personal injury. Always use **NEW** flexible connectors when installing a gas appliance.

CAUTION:

Do not attempt to operate the oven of this range during a power failure (electric ignition models only).

IMPORTANT:

Remove all packing material and literature from oven before connecting gas and electrical supply to range.

INSTALLATION INSTRUCTIONS

DIMENSIONS AND CLEARANCES

Provide adequate clearances between the range and adjacent combustible surfaces.

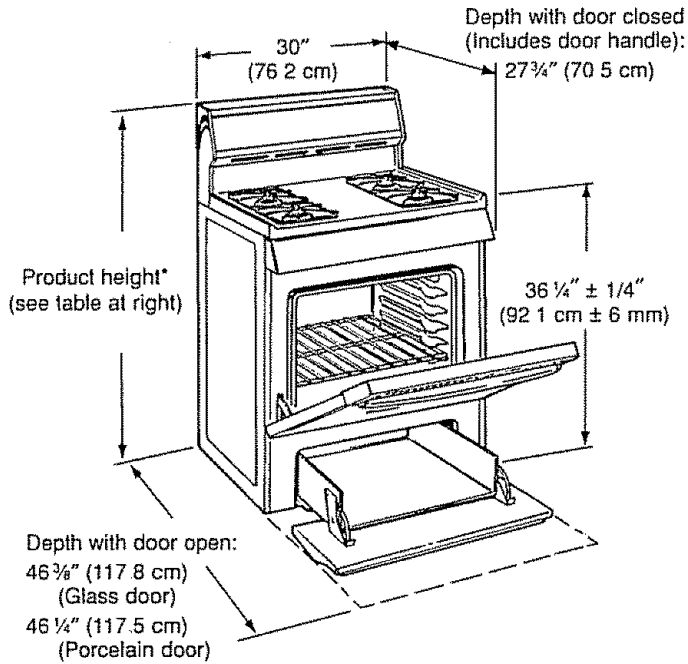

*Product Height:		
40" (101.6 cm)	61020	61120
	61021	61121
	61028	61128
45 ¹ / ₂ " (115.5 cm)	71091	71098
46 ¹ / ₂ " (118.1 cm)	71330	73210
	71331	73211
	71332	73212
	72220	73219
	72221	73220
	72222	73221
	72224	73222
		73224

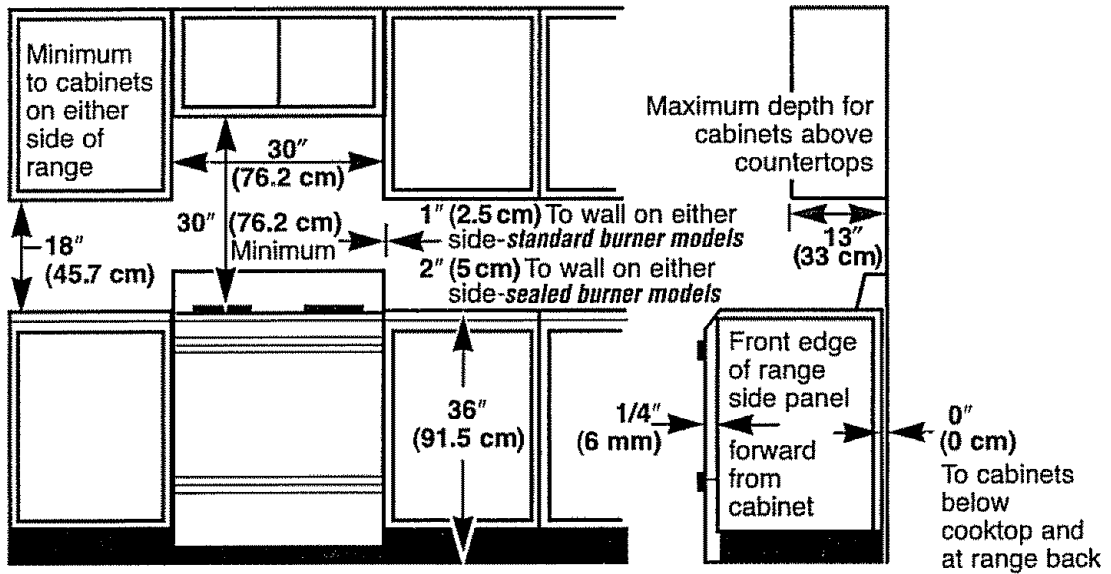

(continued next page)

IMPORTANT SAFETY INSTRUCTIONS

- Installation of this range must conform with local codes, or in the absence of local codes, with the National Fuel Gas Code, ANSI Z223.1, latest edition. In Canada, installation must conform with the current Natural Gas Installation Code, CAN/CGA-B149.1 or the current Propane Installation Code, CAN/CGA-B149.2 and with local codes where applicable.

This range has been design-certified by the American Gas Association according to ANSI Z21.1, latest edition and Canadian Gas Association according to CAN/CGA-1.1 latest edition. As with any appliance using gas and generating heat, there are certain safety precautions you should follow. You will find these precautions in the Important Safety Instructions section in the front of this manual. Read them carefully.

- Have your range installed by a qualified installer.
- Your range must be electrically grounded in accordance with local codes or, in the absence of local codes, in accordance with the National Electrical Code (ANSI/NFPA 70, latest edition). In Canada, electrical grounding must be in accordance with the current CSA-C22.1 Canadian Electrical Code Part 1 and/or local codes. See Electrical Connections in this section.
- Before installing your range on linoleum or any other synthetic floor covering, make sure the floor covering can withstand 180°F (82°C) without shrinking, warping or discoloring. Do not install the range over carpeting unless a sheet of ¼" (6 mm) thick plywood or similar insulator is placed between the range and carpeting.
- Make sure the wall coverings around the range can withstand heat generated by the range up to 200°F (93°C).
- Avoid placing cabinets above the range. To reduce the hazard caused by reaching over the open flames of operating burners, install a ventilation hood over the range that projects forward at least 5" (12.7 cm) beyond the front of the cabinets.
- The ventilating hood must be constructed of sheet metal not less than 0.0122" (.31 mm) thick. Install above the cooking top with a clearance of not less than ¼" (6 mm) between the hood and the underside of the combustible material or metal cabinet. The hood must be at least as wide as the appliance and centered over the appliance. Clearance between the cooking surface and the ventilation hood surface **MUST NEVER BE LESS THAN 24" (61 cm)**.

EXCEPTION: Installation of a listed microwave oven or cooking appliance over the cooktop shall conform to the installation instructions packed with that appliance.

- If cabinets are placed above the range, allow a minimum clearance of 30" (76.2 cm) between the cooking surface and the bottom of unprotected cabinets.
- If a 30" (76.2 cm) clearance between cooking surface and overhead combustible material or metal cabinets cannot be maintained, protect the underside of the cabinets above the cooking top with not less than ¼" (6 mm) insulating millboard covered with sheet metal not less than 0.0122" (.31 mm) thick.
- Clearance between the cooking surface and protected cabinets **MUST NEVER BE LESS THAN 24" (61 cm)**. The vertical distance from the plane of the cooking surface to the bottom of adjacent overhead cabinets extending closer than 1" (2.5 cm) to the plane of the range sides must not be less than 18" (45.7 cm). (See the Dimensions and Clearances illustration in this section.)

- **CAUTION:** Items of interest to children should not be stored in cabinets above a range or on the backsplash of a range—children climbing on the range to reach items could be seriously injured.

WARNING

All ranges can tip and injury could result. To prevent accidental tipping of the range, attach an approved Anti-Tip device to the wall and floor. (See Installing the Anti-Tip Device in this section.)



To check if the device is installed and engaged properly, remove the broiler drawer and inspect the rear leveling leg. Make sure it fits securely into the slot.

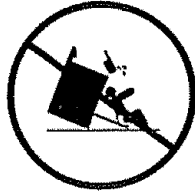

If you pull the range out from the wall for any reason, make sure the Anti-Tip device is engaged when you push the range back against the wall.

- For your safety, never use your range for warming or heating the room. Your oven and cooktop are not designed to heat your kitchen. Top burners should not be operated without cookware on the grate. Such abuse could result in fire and damage to your range and will void your warranty.
- Do not store or use combustible materials, gasoline or other flammable vapors and liquids in the vicinity of this or any other appliance. Explosions or fires could result.
- Do not use oven for a storage area. Items stored in the oven can ignite.
- Do not let cooking grease or other flammable materials accumulate in or near the range.

GENERAL

- See the Dimensions and Clearances illustration in this section for all rough-in and spacing dimensions. These dimensions must be met for safe use of your range. The location of the electrical outlet and pipe opening (see Gas Pipe and Electric Outlet Locations) may be adjusted to meet specific requirements.
- The range may be placed with 0" (0 cm) clearance (flush) at the back wall and side walls of the range.

LOCATION

Do not locate the range where it may be subject to strong drafts. Any openings in the floor or wall behind the range should be sealed. Make sure the openings around the base of the range that supply fresh air for combustion and ventilation are not obstructed by carpeting or woodwork.

PROTECT YOUR FLOOR

Your range, like many other household items, is heavy and can settle into soft floor coverings such as cushioned vinyl or carpeting. Use care when moving the range on this type of flooring. It is recommended that the following simple and inexpensive instructions be followed to protect your floor.

The range should be installed on a sheet of plywood (or similar material). When the floor covering ends at the front of the range, the area that the range will rest on should be built up with plywood to the same level or higher than the floor covering. This will allow the range to be moved for cleaning or servicing.

MODEL AND SERIAL NUMBER LOCATION

Depending on your range, you'll find the model and serial numbers on a label on the front frame of the range, behind the broiler drawer.

TOOLS YOU WILL NEED

- Phillips and flat-blade screwdrivers
- Pencil and ruler
- Two pipe wrenches (one for backup)
- Open-end or adjustable wrench
- Nut drivers or wrenches: 3/16" and 1/4"

ADDITIONAL MATERIALS YOU MAY NEED

- Gas line shut-off valve
- Pipe joint sealant or UL-approved pipe thread tape with Teflon* that resists action of natural and LP gases
- Flexible metal appliance connector (1/2" I.D.). A 5-foot (1.5 m) length is recommended for ease of installation but other lengths are acceptable. Never use an old connector when installing a new range.
- Flare union adapter for connection to gas supply line (3/4" or 1/2" NPT x 1/2" I.D.)
- Flare union adapter for connection to pressure regulator on range (1/2" NPT x 1/2" I.D.)

*Teflon: Registered trademark of DuPont

(continued next page)

INSTALLATION INSTRUCTIONS (continued)

PREPARATION

- Remove all tape and packaging. Lift up the cooktop (on models with standard twin burners) and remove any packing material under it. Make sure the standard twin burners are properly seated and level.
- Remove plastic film that covers some chrome parts (around oven door, side trim).
- Take the accessory pack out of the oven.
- Check to be sure that no range parts have come loose during shipping.

STEP 1

Provide Adequate Gas Supply

Your range is designed to operate at a pressure of 4" (10.2 cm) of water column on natural gas or, if designed for LP gas (propane or butane), 10" (25.4 cm) of water column. Make sure you are supplying your range with the type of gas for which it is designed. This range is convertible for use on natural or propane gas. If you decide to use this range on LP gas, conversion must be made by a qualified LP installer before attempting to operate the range on that gas.

For proper operation, the pressure of natural gas supplied to the regulator must be between 4" (10.2 cm) and 13" (33 cm) of water column. For LP gas, the pressure supplied must be between 10" (25.4 cm) and 13" (33 cm) of water column. When checking for proper operation of the regulator, the inlet pressure must be at least 1" (2.5 cm) greater than the operating (manifold) pressure as given above. The pressure regulator located at the inlet of the range manifold must remain in the supply line regardless of whether natural or LP gas is being used. A flexible metal appliance connector used to connect the range to the gas supply line should have an I.D. of 1/2" and be 5 feet (1.5 m) in length for ease of installation. In Canada, flexible connectors must be single wall metal connectors no longer than 6 feet (1.8 m) in length.

STEP 2

Connect the Range to Gas

Shut off the main gas supply valve before disconnecting the old range and leave it off until new hook-up has been completed. Don't forget to relight the pilot on other gas appliances when you turn the gas back on.

Because hard piping restricts movement of the range, the use of an A.G.A.-certified flexible metal appliance connector is recommended unless local codes require a hard-piped connection. Never use an old connector when installing a new range. If the hard piping method is used, you must carefully align the pipe; the range cannot be moved after the connection is made.

To prevent gas leaks, use pipe joint compound or wrap Teflon* pipe thread tape around all male (external) pipe threads.

*Teflon: Registered trademark of DuPont

Gas Pipe and Electric Outlet Locations for Models Equipped with Sealed Burners

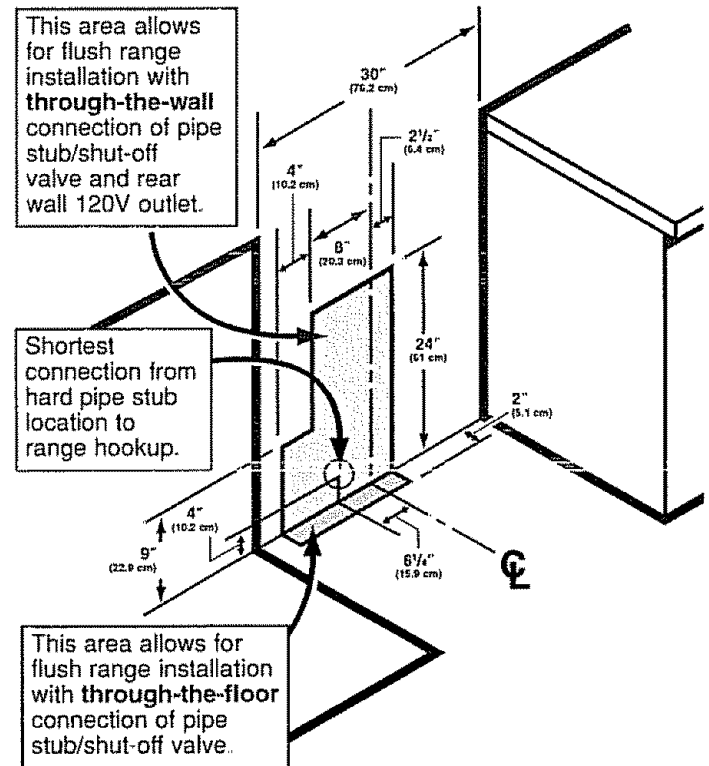

INSTALLATION INSTRUCTIONS (continued)

Gas Pipe and Electric Outlet Locations for Models Equipped with Standard Twin Burners

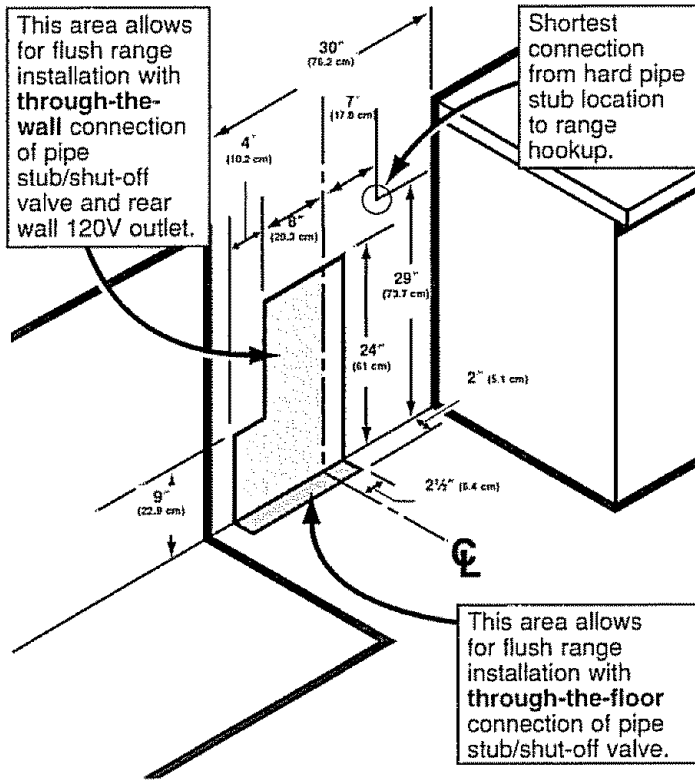

Flexible Connector Hookup for Models Equipped with Sealed Burners

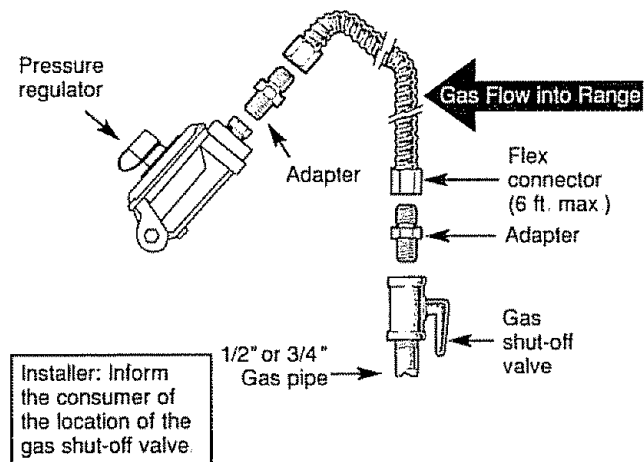

Rigid Pipe Hookup Options for Models Equipped with Sealed Burners

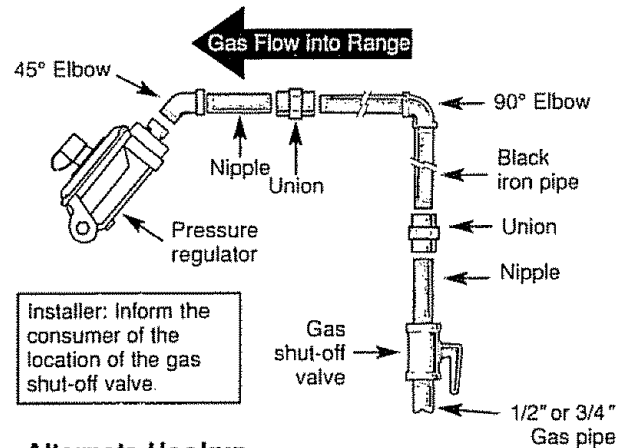

Alternate Hookup

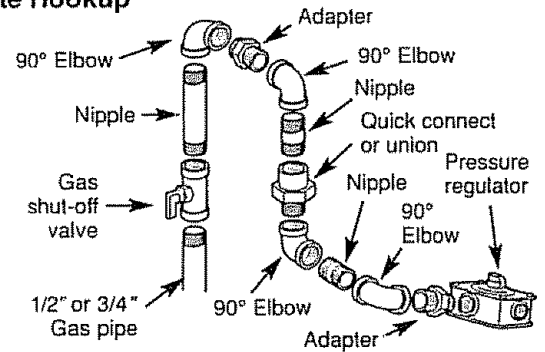

Installer: Inform the consumer of the location of the gas shut-off valve.

Gas Flow Into Range

Flexible Connector and Rigid Pipe Hookup for Models Equipped with Standard Twin Burners

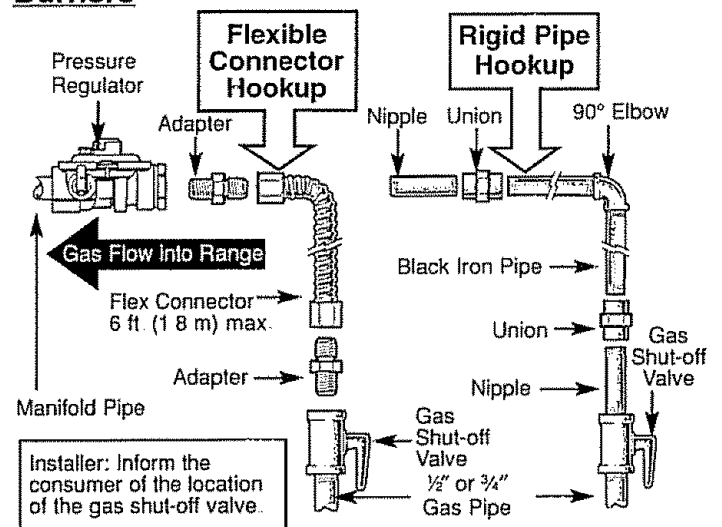

- If the Anti-Tip device supplied with the range does not fit this application, use the universal Anti-Tip device WB02X7909. (continued next page)

INSTALLATION INSTRUCTIONS (continued)

1. Install a manual gas line shut-off valve in the gas line in an easily accessed location outside of the range. Make sure everyone operating the range knows where and how to shut off the gas supply to the range.
2. Install male ½" flare union adapter to the ½" NPT internal thread at inlet of pressure regulator. Use a back-up wrench on the regulator fitting to avoid damage.
3. Install male ½" or ¾" flare union adapter to the NPT internal thread of the manual shut-off valve, taking care to back up the shut-off valve to keep it from turning.
4. Connect flexible metal appliance connector to the adapter on the range. Position range to permit connection at the shut-off valve.
5. When all connections have been made, make sure all range controls are in the OFF position and turn on the main gas supply valve. Use a liquid leak detector at all joints and connections to check for leaks in the system.

WARNING: DO NOT USE A FLAME TO CHECK FOR GAS LEAKS.

When using test pressures greater than ½ psig to pressure test the gas supply system of the residence, disconnect the range and individual shut-off valve from the gas supply piping. When using test pressures of ½ psig or less to test the gas supply system, simply isolate the range from the gas supply system by closing the individual shut-off valve.

STEP 3

Electrical Connections

(on some models)

Electrical Requirements

120-volt, 60 Hertz, properly grounded branch circuit protected by a 15-amp or 20-amp circuit breaker or time delay fuse.

Extension Cord Cautions

Because of potential safety hazards associated with certain conditions, we strongly recommend against the use of an extension cord. However, if you still elect to use an extension cord, it is absolutely necessary that it be a UL-listed, 3-wire grounding-type appliance extension cord and that the current carrying rating of the cord in amperes be equivalent to, or greater than, the branch circuit rating.

Grounding—IMPORTANT (Please read carefully)

FOR PERSONAL SAFETY, THIS APPLIANCE MUST BE PROPERLY GROUNDED.

The power cord of this appliance is equipped with a three-prong (grounding) plug which mates with a standard three-prong grounding wall receptacle to minimize the possibility of electric shock hazard from this appliance.

The customer should have the wall receptacle and circuit checked by a qualified electrician to make sure the receptacle is properly grounded.

Where a standard two-prong wall receptacle is encountered, it is the personal responsibility and obligation of the customer to have it replaced with a properly grounded three-prong wall receptacle.

DO NOT, UNDER ANY CIRCUMSTANCES, CUT OR REMOVE THE THIRD (GROUND) PRONG FROM THE POWER CORD.

A word about GFCI's – GFCI's are not required or recommended for gas range receptacles.

Ground Fault Circuit Interrupters (GFCI's) are devices that sense leakage of current in a circuit and automatically switch off power when a threshold leakage level is detected. These devices must be manually reset by the consumer. The National Electrical Code requires the use of GFCI's in kitchen receptacles installed to serve countertop surfaces. Performance of the range will not be affected if operated on a GFCI-protected circuit but occasional nuisance tripping of the GFCI breaker is possible.

PREFERRED METHOD

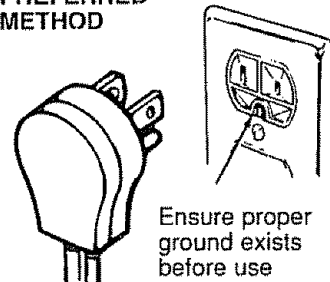

INSTALLATION INSTRUCTIONS (continued)

A: Usage Situations where Appliance Power Cord will be Disconnected Infrequently.

TEMPORARY METHOD

(Adapter plugs not permitted in Canada)

Align large prongs/slots

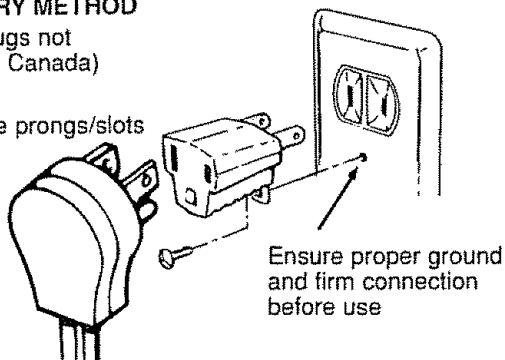

An adapter may be used only on a 15-amp circuit. Do not use an adapter on a 20-amp circuit. Where local codes permit, a **TEMPORARY CONNECTION** may be made to a properly grounded two-prong wall receptacle by the use of a UL-listed adapter, available at most hardware stores. The larger slot in the adapter must be aligned with the larger slot in the wall receptacle to provide proper polarity in the connection of the power cord.

CAUTION: Attaching the adapter ground terminal to the wall receptacle cover screw does not ground the appliance unless the cover screw is metal, and not insulated, and the wall receptacle is grounded through the house wiring. The customer should have the circuit checked by a qualified electrician to make sure the receptacle is properly grounded.

When disconnecting the power cord from the adapter, always hold the adapter with one hand. If this is not done, the adapter ground terminal is very likely to break with repeated use. Should this happen, **DO NOT USE** the appliance until a proper ground has again been established.

B: Usage Situations where Appliance Power Cord will Be Disconnected Frequently.

Do not use an adapter plug in these situations because disconnecting of the power cord places undue strain on the adapter and leads to eventual failure of the adapter ground terminal. The customer should have the two-prong wall receptacle replaced with a three-prong (grounding) receptacle by a qualified electrician before using the appliance.

The installation of appliances designed for mobile home installation must conform with the Manufactured Home Construction and Safety Standard, Title 24 CFR, Part 3280 (formerly the Federal Standard for Mobile Home Construction and Safety, Title 24, HUD, Part 280) or, when such standard is not applicable, the Standard for Manufactured Home Installations, latest edition (Manufactured Home Sites, Communities and Set-Ups), ANSI A225.1, latest edition, or with local codes. In Canada, mobile home installation must be in accordance with the current CAN/CSA Z240/Mtl Mobile Home Installation Code.

Electric Disconnect

1. Locate disconnect plug on the range back.
2. Pinch sides of connector and pull out of range back.

You will have this disconnect plug:

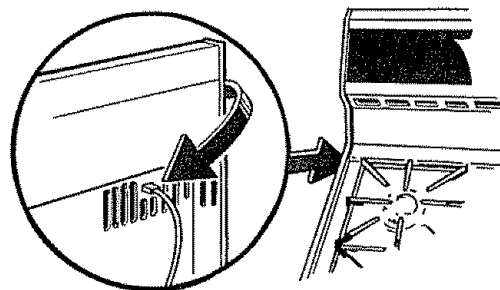

STEP 4 Seal the Openings

Seal any openings in the wall behind the range and in the floor under the range when hookups are completed.

(continued next page)

INSTALLATION INSTRUCTIONS (continued)

STEP 5

Light the Pilots

(for models equipped with standing pilots)

The range should be installed in its permanent position before any pilots are lit or adjusted.

Light the Surface Burner Pilots

CAUTION: Make sure the surface burner control knobs are in the OFF position before attempting to light the pilots.

1. Raise the cooktop.
2. Light both pilots with a match.
3. To avoid pilot outage, use caution when closing cooktop after lighting pilots.

NOTE: Do not leave standing pilot lit in a newly constructed or remodeled home or apartment that will be unoccupied for more than a month.

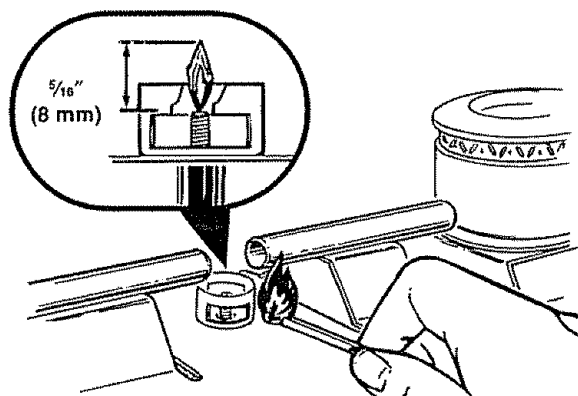

Each pilot flame was adjusted at the factory to be approximately 5/16" (8 mm) tall. A tinge of yellow appearing at the upper tip is normal. If you find pilot adjustment is necessary, follow instructions at right.

Adjust the Surface Burner Pilots If Necessary

1. Raise the cooktop.
2. Locate the pilot adjustment screw. It can be accessed through the small hole near the center of the manifold panel.
3. To adjust, use a blade-type screwdriver with a shaft diameter of less than 3/16" (5 mm). Turn pilot adjustment screw until pilot is 5/16" (8 mm) high. Do not reduce the flame to less than 5/16" (8 mm) or pilot outage may occur. A pilot flame burning higher than recommended may generate soot (carbon black) on the bottom of your cooktop.

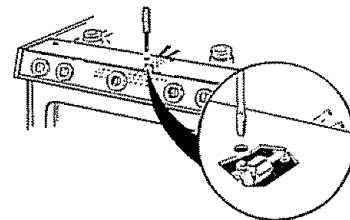

Light the Oven Pilot

CAUTION: Make sure the OVEN TEMP knob is in the OFF position before attempting to light the pilot.

1. Remove the broiler drawer by sliding the drawer all the way out and then lifting slightly to remove it from its tracks.
2. Locate the pilot at the back of the broiler compartment. The pilot is attached to the left side of the oven burner.
3. Light the pilot with a match. No adjustments are required for natural gas. If range is connected to LP gas, contact the person who installed your range or made the conversion.

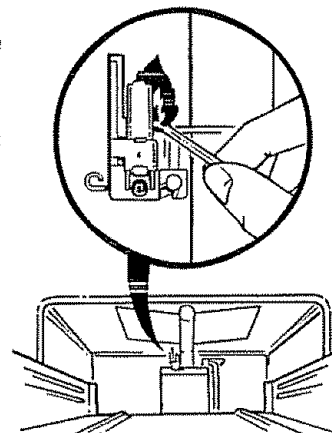

INSTALLATION INSTRUCTIONS (continued)

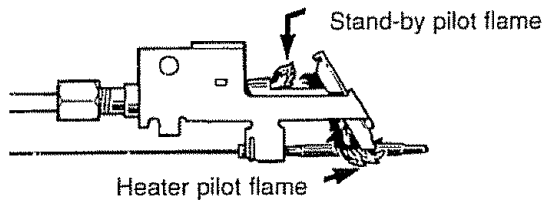

4. Turn the OVEN TEMP knob to a setting above 200°F (93°C). The pilot flame will increase in size and impinge on the temperature-response element. The oven burner will light in 30-90 seconds.

The oven burner will operate until the set temperature is reached. The oven burner will continue to cycle on and off as necessary to maintain the oven at the temperature indicated by the OVEN TEMP knob.

STEP 6

Check Ignition of Surface Burners

Operation of all cooktop and oven burners should be checked after the pilots have been lighted (on some models) and range and gas supply lines have been carefully checked for leaks.

Standing Pilot Models

Select a top burner knob and simultaneously push in and turn to HI position. The burner should light within a few seconds. Try each burner in succession until all burners have been checked.

Electronic Ignition Models

Select a top burner knob and simultaneously push in and turn to LITE position. You will hear a snapping sound indicating proper operation of the spark module. Once the air has been purged from the supply lines, burners should light within 4 seconds. After burner lights, rotate knob out of the LITE position. Try each burner in succession until all burners have been checked.

Quality of Flames

The combustion quality of burner flames needs to be determined visually.

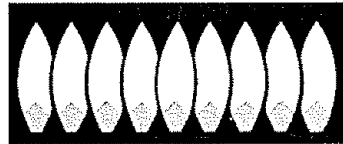

(A) Yellow flames—Call for service

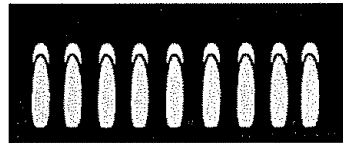

(B) Yellow tips on outer cones—Normal for LP gas



(C) Soft blue flames—Normal for natural gas

If burner flames look like (A), call for service. Normal burner flames should look like (B) or (C), depending on the type of gas you use.

With LP gas, some yellow tipping on outer cones is normal.

STEP 7

Check Ignition of Oven Burner

Your oven is designed to operate quietly and automatically. To operate the oven, turn the OVEN TEMP knob to a setting above 200°F (93°C). After 30–90 seconds, the oven burner will ignite and burn until the set temperature is reached. The oven burner will continue to cycle on and off as necessary to maintain the oven at the temperature indicated by the OVEN TEMP knob.

Electronic ignition models require electrical power to operate. The oven cannot be lit during a power outage. Gas will not flow unless the glow bar is hot.

If the oven is in use when a power outage occurs, the oven burner will shut off and cannot be re-lit until power is restored.

(continued next page)

INSTALLATION INSTRUCTIONS (continued)

STEP 8

Adjusting the Air Adjustment Shutter If Necessary

To determine if the oven burner flames are burning properly, first remove the oven bottom.

To remove the oven bottom:

1. Remove the knurled screws holding down the rear of the oven bottom.
2. Grasp the oven bottom at the finger slots on each side.
3. Lift the rear of the oven bottom enough to clear the lip of the range frame, push it back, and then pull it up and out.

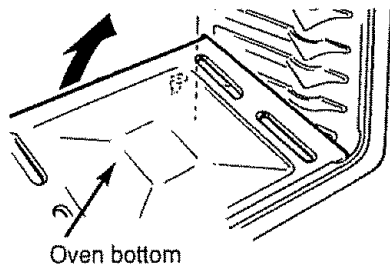

With the oven bottom removed, properly adjusted flames should have approximately 1" (2.5 cm) blue cones and, if range is supplied with natural gas, should burn with no yellow tipping. (With most LP gas, small yellow tips at the end of outer cones are normal.) Flames should not lift off the burner ports. If lifting is observed, gradually reduce air shutter opening until flames are stabilized.

The shutter for the oven burner is near the back wall of the oven and behind the broiler drawer. To remove the broiler drawer:

1. Pull the drawer out until it stops, then push it back in about 1" (2.5 cm).
2. Grasp the handle, lift and pull the broiler drawer out.

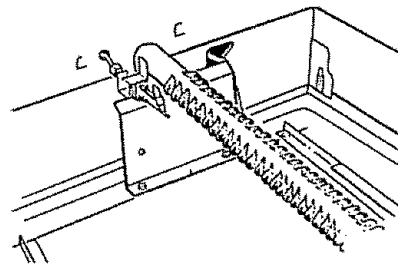

Remove the metal shield at the rear of the drawer cavity. The air adjustment shutter is behind this shield. To adjust the flow of air to the burner, loosen the Phillips-head screw and rotate the shutter to allow more or less air into the burner tube.

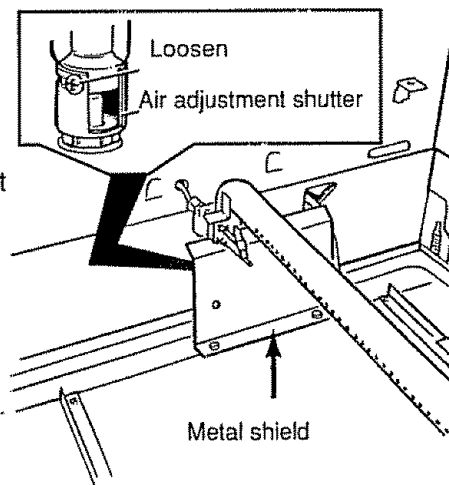

STEP 9

Leveling the Range

1. Install the oven shelves in the oven, then position the range where it will be installed.
2. Check for levelness by placing a spirit level or a partially filled cup of water on one of the oven shelves. If using a spirit level, take two readings—with the level placed diagonally first in one direction and then the other.

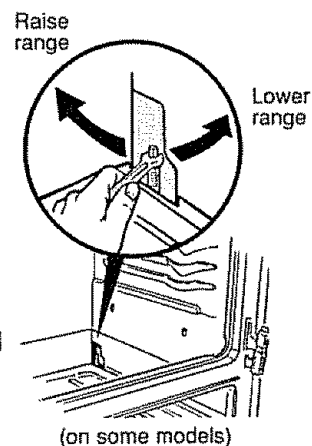

3. Remove the broiler drawer. The front leveling legs can be adjusted from the bottom and the rear legs can be adjusted from the top or the bottom.
4. Use an open-end or adjustable wrench to adjust the leveling legs until the range is level.
5. After the range is level, slide the range away from the wall so that the Anti-Tip device can be installed.

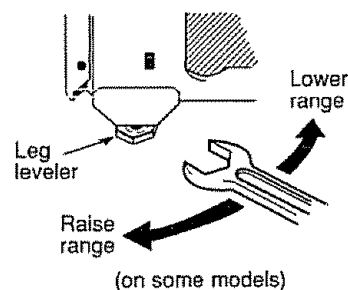

INSTALLATION INSTRUCTIONS (continued)

STEP 10

Installing the Anti-Tip Device

WARNING:

- Range must be secured with an approved Anti-Tip device.
- Unless properly installed, the range could be tipped by you or a child standing, sitting or leaning on an open door.
- After installing the Anti-Tip device, verify that it is properly installed and engaged by removing the broiler drawer and inspecting the rear leveling leg. Make sure it fits securely into the slot.
- This range has been designed to meet all recognized industry tip standards for all normal conditions.
- The installation of the Anti-Tip device must meet all local codes for securing the appliance.
- The use of this device does not preclude tipping of the range when not properly installed.
- If the Anti-Tip device supplied with the range does not fit this application, use the universal Anti-Tip device WB02X7909.

These Anti-Tip device installation instructions are for wood or concrete floors and walls. Any other type of construction may require special installation techniques to provide adequate fastening of the Anti-Tip device to the floor and wall.

1. Locate the device against the rear wall and either the right or left cabinet. If the countertop overhangs the cabinet, offset the device from the cabinet by the amount of overhang. If there is no adjacent cabinet, position the edge of the device at the desired location of the range side panel.
2. Use the device as a template and mark 2 hole positions on the wall and 2 hole positions on the floor. Use either the wood or concrete floor set of positions, depending on your floor type.

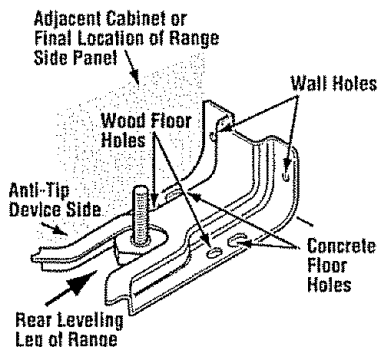

3. For wood construction, drill a 1/8" pilot hole in the center of each of the pre-marked wood floor and wall hole positions (a nail or awl may be used if a drill is not available). Fasten the Anti-Tip device with the 4 screws provided.

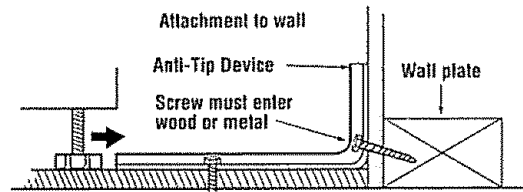

For concrete construction, you will need four 1/4" x 1 1/2" lag bolts and four 1/2" O.D. sleeve anchors (not provided). Drill the recommended size hole for the anchors into the concrete at the center of each pre-marked floor and wall hole position. Install the sleeve anchors into the drilled holes and then install the lag bolts through the device. **Do not overtighten the bolts.**

4. Slide the range against the wall, and check for proper installation by removing the broiler drawer, storage drawer, or kick panel and inspecting the rear leveling leg. Make sure it fits securely into the slot on the Anti-Tip device.

WHEN ALL HOOKUPS ARE COMPLETED:

MAKE SURE ALL OF THE CONTROLS ARE LEFT IN THE OFF POSITION.

MAKE SURE THE FLOW OF COMBUSTION AND VENTILATION AIR TO THE RANGE IS UNOBSTRUCTED.

Converting to LP gas

(or converting back to natural gas from LP)

This range leaves the factory set for use with natural gas. If you want to convert to LP gas, the conversion must be performed by a qualified LP gas installer.

The conversion instructions, sticker and LP orifices can be found attached to the range next to the pressure regulator.

Keep these instructions and the orifices in case you want to convert back to natural gas.

QUESTIONS? BEFORE YOU CALL FOR SERVICE . . .

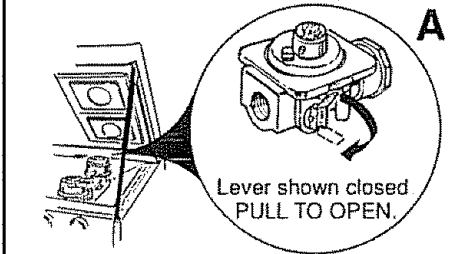
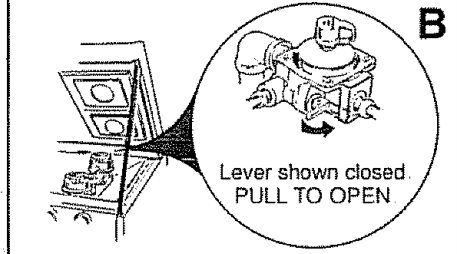
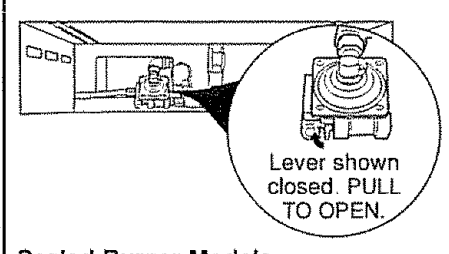
PROBLEM	POSSIBLE CAUSE
TOP BURNERS DO NOT LIGHT OR DO NOT BURN EVENLY	<ul style="list-style-type: none"> • Make sure electrical plug is plugged into a live power outlet. • Burner holes on the side or around the top of burner may be clogged. Remove burners (on models with standard twin burners) or burner heads (on models with sealed burners) or burner caps on spill-proof models, and clean them with a sewing needle or twist-tie. Make sure you do not enlarge the holes. On spill-proof models, check electrode area for burned-on food or grease. • Make sure the drip pans (on some models) are installed correctly. • Pilot(s) is (are) not lit (on standing pilot models). See the Lighting Instructions for Standing Pilot Models section in Surface Cooking.
BURNER FLAMES VERY LARGE OR YELLOW	<ul style="list-style-type: none"> • If range is connected to LP gas, contact the person who installed your range or made the conversion.
SURFACE BURNERS LIGHT BUT OVEN DOES NOT	<ul style="list-style-type: none"> • The oven gas shut-off valve may have accidentally been moved during cleaning or moving. <p>To check the oven gas shut-off valve on standard twin burner models, raise the cooktop and look for the gas shut-off lever at the extreme right rear corner. Follow the directions in box A or B that match your regulator type.</p> <div style="display: flex; justify-content: space-around; align-items: flex-start;"> <div style="border: 1px solid black; padding: 5px; text-align: center;">  <p>Standard Twin Burner Models</p> </div> <div style="border: 1px solid black; padding: 5px; text-align: center;">  <p>Standard Twin Burner Models</p> </div> </div> <p>To check the oven gas shut-off valve on sealed burner models, remove the broiler drawer and look for the gas shut-off lever at the back of the range.</p> <div style="border: 1px solid black; padding: 5px; text-align: center;">  <p>Sealed Burner Models</p> </div>

QUESTIONS? BEFORE YOU CALL FOR SERVICE . . .

PROBLEM	POSSIBLE CAUSE
CLOCK DOES NOT WORK	<ul style="list-style-type: none"> • Range electrical plug must be securely seated in a live power outlet. Check for blown fuse or tripped circuit breaker.
OVEN LIGHT DOES NOT COME ON	<ul style="list-style-type: none"> • Bulb may be loose or burned out. • Electrical plug must be plugged into a live power outlet.
OVEN WILL NOT WORK	<ul style="list-style-type: none"> • Plug on the range is not completely inserted in the electrical outlet. • Pilot(s) is (are) not lit (on standing pilot models). See the Lighting Instructions for Standing Pilot Models section in Using Your Oven. • The circuit breaker in your house has been tripped, or a fuse has been blown. • Oven controls not properly set.
OVEN TEMPERATURE TOO HOT OR TOO COLD	<ul style="list-style-type: none"> • The OVEN TEMP knob needs adjustment. See the Adjust the Oven Thermostat—Do It Yourself section.
FOOD DOES NOT ROAST OR BAKE PROPERLY	<ul style="list-style-type: none"> • Oven controls not properly set. See the Baking or Roasting section. • Shelf position is not correct. • Incorrect cookware or cookware of improper size is being used. • Oven thermostat needs adjustment. See the Adjust the Oven Thermostat—Do It Yourself section. • Aluminum foil used improperly in the oven. • Oven bottom not securely seated in position.
FOOD DOES NOT BROIL PROPERLY	<ul style="list-style-type: none"> • Oven controls not properly set. See the Broiling section. • Oven door and/or broiler drawer not closed. • Improper shelf position being used. See the Broiling section. • Food is being cooked on a hot pan. • Cookware is not suited for broiling. • Aluminum foil used on the broiler pan grid has not been fitted properly and slit as recommended. • Oven bottom not securely seated in position.
STRONG ODOR	<ul style="list-style-type: none"> • Improper air/gas ratio in oven. Adjust oven burner air shutter. • An odor from the insulation around the oven liner is normal for the first few times oven is used. This is temporary.



FREE-STANDING GAS RANGE WARRANTY

FULL ONE-YEAR WARRANTY ON ALL PARTS

If, within one year from the date of installation, any part fails to function properly due to a defect in material or workmanship, Sears will repair or replace it, at our option, free of charge.

If this product is subjected to other than private family use, the above warranty is effective for only 90 days.

WARRANTY SERVICE IS AVAILABLE BY CONTACTING SEARS SERVICE AT 1-800-4-MY-HOME.®

This warranty applies only while this product is in use in the United States.

This warranty gives you specific legal rights, and you may also have other rights which vary from state to state.

Sears Roebuck and Co. Dept. 817 WA Hoffman Estates, IL 60179

Master Protection Agreements

Congratulations on making a smart purchase. Your new Kenmore® appliance is designed and manufactured for years of dependable operation. But like all products, it may require preventive maintenance or repair from time to time. That's when having a Master Protection Agreement can save you money and aggravation.

Purchase a Master Protection Agreement now and protect yourself from unexpected hassle and expense.

The Master Protection Agreement also helps extend the life of your new appliance. Here's what's included in the Agreement:

- ✓ **Expert service** by our 12,000 professional repair specialists
- ✓ **Unlimited service and no charge** for parts and labor on all covered repairs
- ✓ **"No-lemon" guarantee**—replacement of your covered product if more than three product failures occur within twelve months
- ✓ **Product replacement** if your covered product can't be fixed
- ✓ **Annual Preventive Maintenance Check** at your request—no extra charge
- ✓ **Fast help by phone**—non-technical and instructional assistance on products repaired in your home, plus convenient repair scheduling
- ✓ **Power surge protection** against electrical damage due to power fluctuations
- ✓ **Rental reimbursement** if repair of your covered product takes longer than promised

Once you purchase the Agreement, a simple phone call is all that it takes for you to schedule service. You can call anytime day or night, or schedule a service appointment online.

Sears has over 12,000 professional repair specialists, who have access to over 4.5 million quality parts and accessories. That's the kind of professionalism you can count on to help prolong the life of your new purchase for years to come. Purchase your Master Protection Agreement today!

Some limitations and exclusions apply.

For prices and additional information, call 1-800-827-6655.

Sears Installation Service

For Sears guaranteed professional installation of home appliances and items like garage door openers and water heaters, call 1-800-4-MY-HOME.®