

OPERATOR'S MANUAL

CRAFTSMAN[®]

3/8 in., 14.4 VOLT CORDLESS DRILL-DRIVER VARIABLE SPEED/REVERSIBLE

Model No.
315.115470

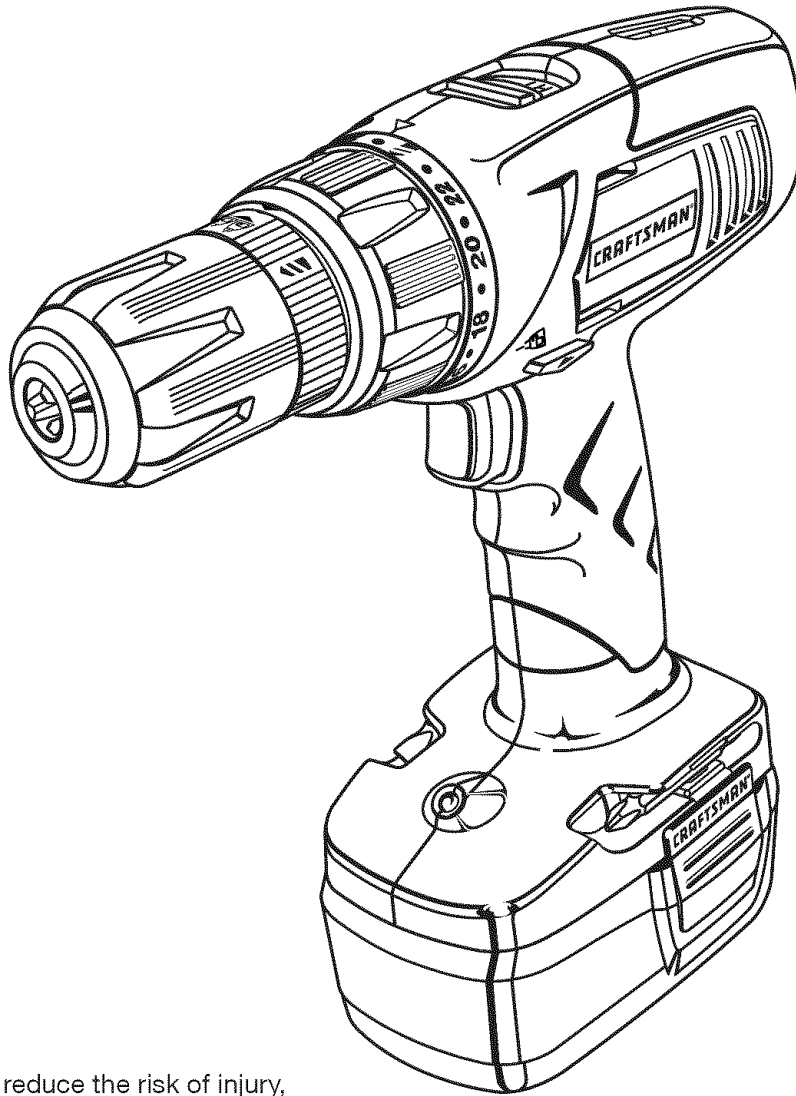

⚠ WARNING: To reduce the risk of injury, the user must read and understand the operator's manual before using this product.

Customer Help Line: 1-800-932-3188

Sears, Roebuck and Co., 3333 Beverly Rd., Hoffman Estates, IL 60179 USA
Visit the Craftsman web page: www.sears.com/craftsman

TABLE OF CONTENTS

■ Warranty	2
■ Introduction	2
■ General Safety Rules	3-4
■ Specific Safety Rules	4
■ Safety Rules for Charger	5
■ Symbols	6-7
■ Features	8-9
■ Assembly	9
■ Operation	10-17
■ Maintenance	18-19
■ Exploded View and Parts List	20
■ Parts Ordering/Service	Back Page

WARRANTY

ONE-YEAR FULL WARRANTY ON CRAFTSMAN TOOL

If this Craftsman tool fails to give complete satisfaction within one year from date of purchase, **RETURN IT TO ANY SEARS STORE OR PARTS AND REPAIR CENTER OR OTHER CRAFTSMAN OUTLET IN THE IN THE UNITED STATES FOR FREE REPAIR.**

If this Craftsman tool is used for commercial or rental purposes, this warranty applies for only 90 days from the date of purchase.

This warranty gives you specific legal rights, and you may also have other rights which vary from state to state.

Sears, Roebuck and Co., Dept. 817WA, Hoffman Estates, IL 60179

INTRODUCTION

This tool has many features for making its use more pleasant and enjoyable. Safety, performance, and dependability have been given top priority in the design of this product making it easy to maintain and operate.

GENERAL SAFETY RULES

⚠ WARNING! Read all instructions. Failure to follow all instructions listed below may result in electric shock, fire and/or serious injury. The term “power tool” in all of the warnings listed below refers to your mains-operated (corded) power tool or battery-operated (cordless) power tool.

SAVE THESE INSTRUCTIONS

WORK AREA SAFETY

- **Keep work area clean and well lit.** Cluttered or dark areas invite accidents.
- **Do not operate power tools in explosive atmospheres, such as in the presence of flammable liquids, gases or dust.** Power tools create sparks which may ignite the dust or fumes.
- **Keep children and bystanders away while operating a power tool.** Distractions can cause you to lose control.

ELECTRICAL SAFETY

- **Power tool plugs must match the outlet. Never modify the plug in any way. Do not use any adapter plugs with earthed (grounded) power tools.** Unmodified plugs and matching outlets will reduce risk of electric shock.
- **Avoid body contact with earthed or grounded surfaces such as pipes, radiators, ranges and refrigerators.** There is an increased risk of electric shock if your body is earthed or grounded.
- **Do not expose power tools to rain or wet conditions.** Water entering a power tool will increase the risk of electric shock.
- **Do not abuse the cord. Never use the cord for carrying, pulling or unplugging the power tool. Keep cord away from heat, oil, sharp edges or moving parts.** Damaged or entangled cords increase the risk of electric shock.
- **When operating a power tool outdoors, use an extension cord suitable for outdoor use.** Use of a cord suitable for outdoor use reduces the risk of electric shock.
- **Use battery only with charger listed.**

MODEL	BATTERY PACK	CHARGER
315.115470	130279002 (Item No. 911044)	Model No. 1425301 (Item No. 911041) Model No. 315.115730 (Item No. 140301003)

PERSONAL SAFETY

- **Stay alert, watch what you are doing and use common sense when operating a power tool. Do not use a power tool while you are tired or under the influence of drugs, alcohol or medication.** A moment of inattention while operating power tools may result in serious personal injury.
- **Use safety equipment. Always wear eye protection.** Safety equipment such as dust mask, non-skid safety

shoes, hard hat, or hearing protection used for appropriate conditions will reduce personal injuries.

- **Avoid accidental starting. Ensure the switch is in the off-position before plugging in.** Carrying power tools with your finger on the switch or plugging in power tools that have the switch on invites accidents.
- **Remove any adjusting key or wrench before turning the power tool on.** A wrench or a key left attached to a rotating part of the power tool may result in personal injury.
- **Do not overreach. Keep proper footing and balance at all times.** This enables better control of the power tool in unexpected situations.
- **Dress properly. Do not wear loose clothing or jewelry. Keep your hair, clothing and gloves away from moving parts.** Loose clothes, jewelry, or long hair can be caught in moving parts.
- **If devices are provided for the connection of dust extraction and collection facilities, ensure these are connected and properly used.** Use of these devices can reduce dust-related hazards.
- **Do not wear loose clothing or jewelry. Contain long hair.** Loose clothes, jewelry, or long hair can be drawn into air vents.
- **Do not use on a ladder or unstable support.** Stable footing on a solid surface enables better control of the power tool in unexpected situations.

POWER TOOL USE AND CARE

- **Do not force the power tool. Use the correct power tool for your application.** The correct power tool will do the job better and safer at the rate for which it was designed.
- **Do not use the power tool if the switch does not turn it on and off.** Any power tool that cannot be controlled with the switch is dangerous and must be repaired.
- **Disconnect the plug from the power source and/or the battery pack from the power tool before making any adjustments, changing accessories, or storing power tools.** Such preventive safety measures reduce the risk of starting the power tool accidentally.
- **Store idle power tools out of the reach of children and do not allow persons unfamiliar with the power tool or these instructions to operate the power tool.** Power tools are dangerous in the hands of untrained users.
- **Maintain power tools. Check for misalignment or binding of moving parts, breakage of parts, and any other condition that may affect the power tool's operation. If damaged, have the power tool repaired before use.** Many accidents are caused by poorly maintained power tools.
- **Keep cutting tools sharp and clean.** Properly maintained cutting tools with sharp cutting edges are less likely to bind and are easier to control.

GENERAL SAFETY RULES

- **Use the power tool, accessories and tool bits etc., in accordance with these instructions and in the manner intended for the particular type of power tool, taking into account the working conditions and the work to be performed.** Use of the power tool for operations different from those intended could result in a hazardous situation.

BATTERY TOOL USE AND CARE

- **Ensure the switch is in the off position before inserting battery pack.** Inserting the battery pack into power tools that have the switch on invites accidents.
- **Recharge only with the charger specified by the manufacturer.** A charger that is suitable for one type of battery pack may create a risk of fire when used with another battery pack.
- **Use power tools only with specifically designated battery packs.** Use of any other battery packs may create a risk of injury and fire.
- **When battery pack is not in use, keep it away from other metal objects like paper clips, coins, keys, nails, screws, or other small metal objects that can make a connection from one terminal to another.**

Shorting the battery terminals together may cause burns or a fire.

- **Under abusive conditions, liquid may be ejected from the battery, avoid contact. If contact accidentally occurs, flush with water. If liquid contacts eyes, additionally seek medical help.** Liquid ejected from the battery may cause irritation or burns.

SERVICE

- **Have your power tool serviced by a qualified repair person using only identical replacement parts.** This will ensure that the safety of the power tool is maintained.

 **WARNING!** To reduce the risk of injury, user must read instruction manual.

- **When servicing a power tool, use only identical replacement parts. Follow instructions in the Maintenance section of this manual.** Use of unauthorized parts or failure to follow Maintenance instructions may create a risk of shock or injury.

SPECIFIC SAFETY RULES

- **Hold power tools by insulated gripping surfaces when performing an operation where the cutting tool may contact hidden wiring or its own cord.** Contact with a “live” wire will also make exposed metal parts of the tool “live” and shock the operator.
- **Know your power tool. Read operator’s manual carefully. Learn its applications and limitations, as well as the specific potential hazards related to this power tool.** Following this rule will reduce the risk of electric shock, fire, or serious injury.
- **Always wear safety glasses with side shields.** Everyday glasses have only impact resistant lenses. They are NOT safety glasses. Following this rule will reduce the risk of eye injury.
- **Protect your lungs. Wear a face or dust mask if the operation is dusty.** Following this rule will reduce the risk of serious personal injury.
- **Protect your hearing. Wear hearing protection during extended periods of operation.** Following this rule will reduce the risk of serious personal injury.
- **Battery tools do not have to be plugged into an electrical outlet; therefore, they are always in operating condition. Be aware of possible hazards when not using your battery tool or when changing accessories.** Following this rule will reduce the risk of electric shock, fire, or serious personal injury.

- **Do not place battery tools or their batteries near fire or heat.** This will reduce the risk of explosion and possibly injury.
- **Never use a battery that has been dropped or received a sharp blow.** A damaged battery is subject to explosion. Properly dispose of a dropped or damaged battery immediately.
- **Batteries vent hydrogen gas and can explode in the presence of a source of ignition, such as a pilot light.** To reduce the risk of serious personal injury, never use any cordless product in the presence of open flame. An exploded battery can propel debris and chemicals. If exposed, flush with water immediately.
- **Do not charge battery tool in a damp or wet location.** Following this rule will reduce the risk of electric shock.
- **For best results, your battery tool should be charged in a location where the temperature is more than 50°F but less than 100°F. Do not store outside or in vehicles.**
- **Under extreme usage or temperature conditions, battery leakage may occur. If liquid comes in contact with your skin, wash immediately with soap and water, then neutralize with lemon juice or vinegar. If liquid gets into your eyes, flush them with clean water for at least 10 minutes, then seek immediate medical attention.** Following this rule will reduce the risk of serious personal injury.

SAFETY RULES FOR CHARGER

⚠ WARNING! READ AND UNDERSTAND ALL INSTRUCTIONS. Failure to follow all instructions listed below, may result in electric shock, fire and/or serious personal injury.

■ **Before using battery charger**, read all instructions and cautionary markings in this manual, on battery charger, battery, and product using battery to prevent misuse of the products and possible injury or damage.

⚠ CAUTION: To reduce the risk of electric shock or damage to the charger and battery, charge only nickel-cadmium rechargeable batteries as specifically designated on your charger. Other types of batteries may burst, causing personal injury or damage.

■ **Do not use charger outdoors or expose to wet or damp conditions.** Water entering charger will increase the risk of electric shock.

■ **Use of an attachment not recommended or sold by the battery charger manufacturer may result in a risk of fire, electric shock, or injury to persons.** Following this rule will reduce the risk of electric shock, fire, or serious personal injury.

■ **Do not abuse cord or charger.** Never use the cord to carry the charger. Do not pull the charger cord rather than the plug when disconnecting from receptacle. Damage to the cord or charger could occur and create an electric shock hazard. Replace damaged cords immediately.

■ **Make sure cord is located so that it will not be stepped on, tripped over, come in contact with sharp edges or moving parts or otherwise subjected to damage or stress.** This will reduce the risk of accidental falls, which could cause injury, and damage to the cord, which could result in electric shock.

■ **Keep cord and charger from heat to prevent damage to housing or internal parts.**

■ **Do not let gasoline, oils, petroleum-based products, etc. come in contact with plastic parts.** They contain chemicals that can damage, weaken, or destroy plastic.

■ **An extension cord should not be used unless absolutely necessary.** Use of improper extension cord could result in a risk of fire and electric shock. If extension cord must be used, make sure:

- That pins on plug of extension cord are the same number, size and shape as those of plug on charger.
- That extension cord is properly wired and in good electrical condition; and
- That wire size is large enough for AC ampere rating of charger as specified below:

Cord Length (Feet)	25'	50'	100'
Cord Size (AWG)	16	16	16

NOTE: AWG = American Wire Gauge

■ **Do not operate charger with a damaged cord or plug**, which could cause shorting and electric shock. If damaged, have the charger replaced by an authorized serviceman.

■ **Do not operate charger if it has received a sharp blow, been dropped, or otherwise damaged in any way.** Take it to an authorized serviceman for electrical check to determine if the charger is in good working order.

■ **Do not disassemble charger.** Take it to an authorized serviceman when service or repair is required. Incorrect reassembly may result in a risk of electric shock or fire.

■ **Unplug charger from outlet before attempting any maintenance or cleaning to reduce the risk of electric shock.**

■ **Disconnect charger from the power supply when not in use.** This will reduce the risk of electric shock or damage to the charger if metal items should fall into the opening. It also will help prevent damage to the charger during a power surge.

■ **Risk of electric shock.** Do not touch uninsulated portion of output connector or uninsulated battery terminal.

■ **Save these instructions.** Refer to them frequently and use them to instruct others who may use this tool. If you loan someone this tool, loan them these instructions also to prevent misuse of the product and possible injury.











⚠ WARNING: Some dust created by power sanding, sawing, grinding, drilling, and other construction activities contains chemicals known to cause cancer, birth defects or other reproductive harm. Some examples of these chemicals are:

- lead from lead-based paints,
- crystalline silica from bricks and cement and other masonry products, and
- arsenic and chromium from chemically-treated lumber.

Your risk from these exposures varies, depending on how often you do this type of work. To reduce your exposure to these chemicals: work in a well ventilated area, and work with approved safety equipment, such as those dust masks that are specially designed to filter out microscopic particles.



SYMBOLS

Some of the following symbols may be used on this tool. Please study them and learn their meaning. Proper interpretation of these symbols will allow you to operate the tool better and safer.

SYMBOL	NAME	DESIGNATION/EXPLANATION
V	Volts	Voltage
A	Amperes	Current
Hz	Hertz	Frequency (cycles per second)
W	Watt	Power
min	Minutes	Time
~	Alternating Current	Type of current
==	Direct Current	Type or a characteristic of current
n_0	No Load Speed	Rotational speed, at no load
	Class II Construction	Double-insulated construction
.../min	Per Minute	Revolutions, strokes, surface speed, orbits etc., per minute
	Wet Conditions Alert	Do not expose to rain or use in damp locations.
	Read The Operator's Manual	To reduce the risk of injury, user must read and understand operator's manual before using this product.
	Eye Protection	Always wear safety goggles or safety glasses with side shields, or a full face shield when operating this product.
	Safety Alert	Precautions that involve your safety.
	No Hands Symbol	Failure to keep your hands away from the blade will result in serious personal injury.
	No Hands Symbol	Failure to keep your hands away from the blade will result in serious personal injury.
	No Hands Symbol	Failure to keep your hands away from the blade will result in serious personal injury.
	No Hands Symbol	Failure to keep your hands away from the blade will result in serious personal injury.
	Hot Surface	To reduce the risk of injury or damage, avoid contact with any hot surface.

SYMBOLS

The following signal words and meanings are intended to explain the levels of risk associated with this product.

SYMBOL	SIGNAL	MEANING
	DANGER:	Indicates an imminently hazardous situation, which, if not avoided, will result in death or serious injury.
	WARNING:	Indicates a potentially hazardous situation, which, if not avoided, could result in death or serious injury.
	CAUTION:	Indicates a potentially hazardous situation, which, if not avoided, may result in minor or moderate injury.
	CAUTION:	(Without Safety Alert Symbol) Indicates a situation that may result in property damage.

SERVICE

Servicing requires extreme care and knowledge and should be performed only by a qualified service technician. For service we suggest you return the product to your nearest **AUTHORIZED SERVICE CENTER** for repair. When servicing, use only identical replacement parts.



WARNING: To avoid serious personal injury, do not attempt to use this product until you read thoroughly and understand completely the operator's manual. Save this operator's manual and review frequently for continuing safe operation and instructing others who may use this product.

WARNING:



The operation of any power tool can result in foreign objects being thrown into your eyes, which can result in severe eye damage. Before beginning power tool operation, always wear safety goggles or safety glasses with side shields, or a full face shield when needed. We recommend Wide Vision Safety Mask for use over eyeglasses or standard safety glasses with side shields. Always use eye protection which is marked to comply with ANSI Z87.1.

SAVE THESE INSTRUCTIONS

FEATURES

PRODUCT SPECIFICATIONS

Chuck 3/8 in. Keyless
 Motor 14.4 Volt DC
 Switch VSR (Variable Speed Reversible)
 Gear Train 2 Speed
 No Load Speed 0-400/0-1,400/min.

Clutch 24 Position
 Torque 300 in.lb.
 Charger Input 120 V, 60 Hz, AC only
 Charge Rate 1 hour

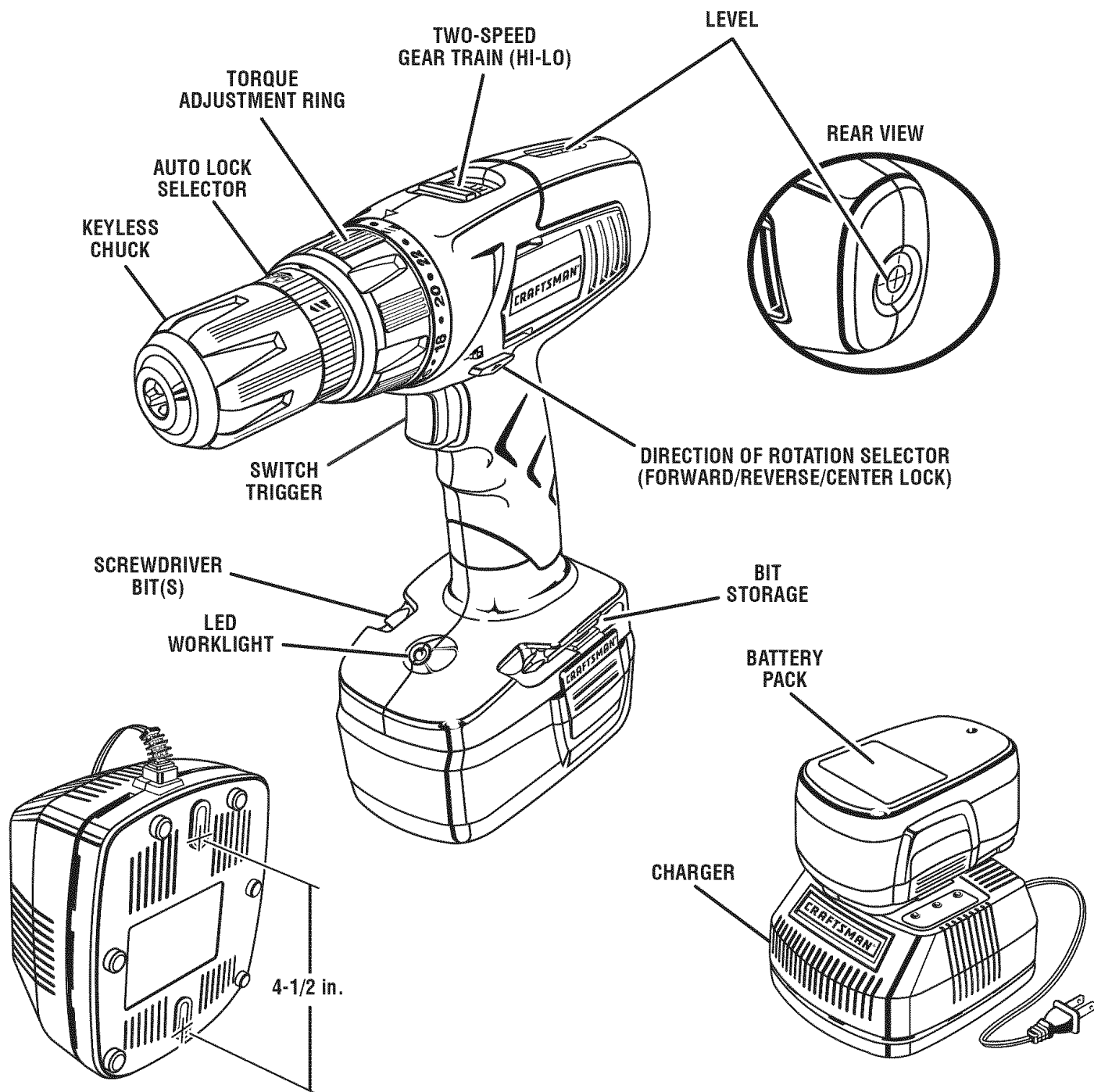

Fig. 1

FEATURES

KNOW YOUR DRILL-DRIVER

See Figure 1.

Before attempting to use this product, familiarize yourself with all operating features and safety rules.

AUTO LOCK SELECTOR

Bits can be changed quickly using the auto lock chuck feature. Placing the auto lock selector in auto lock mode and changing the direction of rotation will open the chuck jaws or tighten them around the bit.

BIT STORAGE

Bits provided with the drill-driver can be placed in the storage area, located on the base of the drill.

DIRECTION OF ROTATION SELECTOR (FORWARD/REVERSE/CENTER LOCK)

Your drill has a direction of rotation (forward/reverse/center lock) selector located above the switch trigger for changing the direction of bit rotation. Setting the switch trigger in the **OFF** (center lock) position helps reduce the possibility of accidental starting when not in use.

KEYLESS CHUCK

The keyless chuck allows you to hand tighten or release the drill bit in the chuck jaws.

LED WORKLIGHT

The LED worklight, located on the front of the tool base, illuminates when the switch trigger is depressed. This provides extra light for increased visibility.

LEVELS

Levels are located on the top and end of the motor housing to help keep the drill bit level during use.

TORQUE ADJUSTMENT RING

Your drill-driver has a 24-position clutch. The torque adjustment ring can be turned to select the right amount of torque for your application.

VARIABLE SPEED

The variable speed switch trigger delivers higher speed with increased trigger pressure and lower speed with decreased trigger pressure.

ASSEMBLY

UNPACKING

This product has been shipped completely assembled.

- Carefully remove the tool and accessories from the box. Make sure that all items listed in the packing list are included.
- Inspect the tool carefully to make sure no breakage or damage occurred during shipping.
- Do not discard the packing material until you have carefully inspected and satisfactorily operated the tool.
- If any parts are damaged or missing, please call 1-800-932-3188 for assistance.

PACKING LIST

3/8 in. Drill-Driver
Charger
Battery Packs (2)
Double-ended Bits (2)
Case
Operator's Manual

 **WARNING:** If any parts are damaged or missing do not operate this tool until the damaged or missing parts are replaced. Failure to do so could result in possible serious personal injury.

 **WARNING:** Do not attempt to modify this tool or create accessories not recommended for use with this tool. Any such alteration or modification is misuse and could result in a hazardous condition leading to possible serious personal injury.

 **WARNING:** To prevent accidental starting that could cause serious personal injury, always remove the battery pack from the tool when assembling parts.

OPERATION

⚠ WARNING: Do not allow familiarity with tools to make you careless. Remember that a careless fraction of a second is sufficient to inflict serious injury.

⚠ WARNING: Always wear safety goggles or safety glasses with side shields when operating tools. Failure to do so could result in objects being thrown into your eyes, resulting in possible serious injury.

⚠ WARNING: Do not use any attachments or accessories not recommended by the manufacturer of this tool. The use of attachments or accessories not recommended can result in serious personal injury.

APPLICATIONS

You may use this tool for the purposes listed below:

- Drilling in wood
- Drilling in ceramics, plastics, fiberglass, and laminates
- Drilling in metals
- Mixing paint

CAUTION: If at any point during the charging process none of the LEDs are lit, remove the battery pack from the charger to avoid damaging the product. DO NOT insert another battery. Return the charger and battery to your nearest service center for service or replacement.

LED FUNCTIONS OF CHARGER

LED WILL BE ON TO INDICATE STATUS OF CHARGER AND BATTERY PACK:

- Red LED on = Fast charging mode.
- Green LED on = Fully charged and in maintenance charge mode.
- Green LED on = When battery pack is inserted into charger, indicates hot battery pack or that battery pack is out of normal temperature range.
- Yellow and Green LEDs on = Deeply discharged or defective battery pack.
- No LED on = Defective charger or battery pack.

CHARGING THE BATTERY PACK

The battery pack for this tool has been shipped in a low charge condition to prevent possible problems. Therefore, you should charge it until the green LED on the front of the charger comes on.

NOTE: Batteries will not reach full charge the first time they are charged. Allow several cycles (operation followed by recharging) for them to become fully charged.

CHARGING A COOL BATTERY PACK

If battery pack is below normal temperature range, the green LED on charger will come on. Allow battery pack to reach normal temperature, then the red LED will come on.

NOTE: If the charger does not charge the battery pack under normal circumstances, return both the battery pack and charger to your nearest Sears Repair Center for electrical check.

- Charge the battery pack only with the charger provided.
- Make sure the power supply is normal household voltage, **120 volts, 60 Hz, AC only**.
- Connect the charger to the power supply.
- Place the battery pack in the charger aligning raised rib on the battery pack with the groove in the charger. See *Figure 2*.
- Press down on the battery pack to be sure contacts on the battery pack engage properly with contacts in the charger.
- Normally the red LED on charger will come on. This indicates the charger is in fast charging mode.
- Red LED should remain on for approximately 1 hour then the green LED will come on. Green LED on indicates battery pack is fully charged and charger is in maintenance charge mode.

NOTE: The green LED will remain on until the battery pack is removed from the charger or charger is disconnected from the power supply.

- If both yellow and green LEDs come on, this indicates a deeply discharged or defective battery pack. Allow the battery pack to remain in the charger for 15 to 30 minutes. When the battery pack reaches normal voltage range, the red LED should come on. If the red LED does not come on after 30 minutes, this may indicate a defective battery pack and should be replaced.
 - After normal usage, a minimum of 1 hour of charging time is required to fully recharge battery pack.
 - The battery pack will become slightly warm to the touch while charging. This is normal and does not indicate a problem.
 - Do not place the charger and battery pack in an area of extreme heat or cold. They will work best at normal room temperature.
- NOTE:** The charger and battery pack should be placed in a location where the temperature is more than 50°F but less than 100°F.
- When batteries become fully charged, unplug the charger from power supply and remove the battery pack.

OPERATION

CHARGING A HOT BATTERY PACK

When using the tool continuously, the batteries in the battery pack will become hot. You should let a hot battery pack cool down for approximately 30 minutes before attempting to recharge. When the battery pack becomes discharged and is hot, this will cause the green LED to come on instead of the red LED. After 30 minutes, reinsert the battery pack in the charger. If the green LED continues to remain on, return battery pack to your nearest Sears Repair Center for checking or replacing.

NOTE: This situation only occurs when continuous use of the tool causes the batteries to become hot. It does not occur under normal circumstances. Refer to "Charging a Cool Battery Pack" for normal recharging of batteries. If the charger does not charge your battery pack under normal circumstances, return both the battery pack and charger to your nearest Sears Repair Center for electrical check.

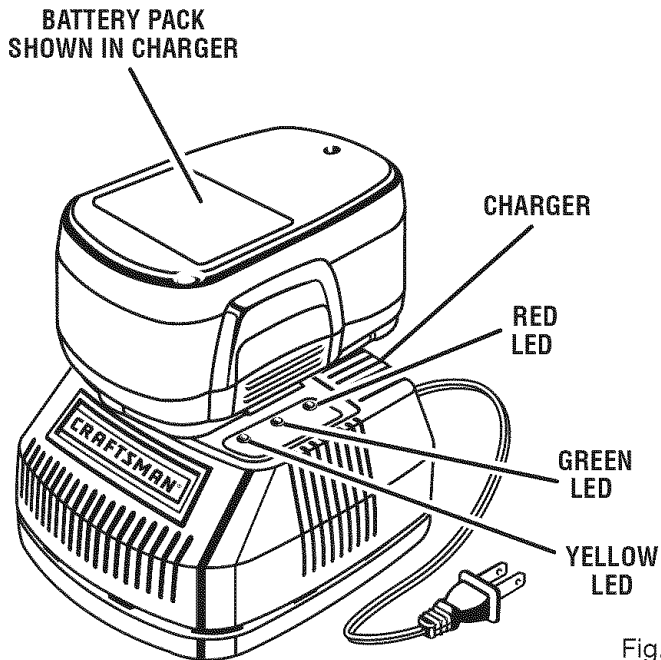

Fig. 2

TO INSTALL BATTERY PACK

See Figure 3.

- Lock switch trigger on the drill by placing the direction of rotation selector in center position.
- Place the battery pack in the drill. Align raised rib on battery pack with groove in drill's battery port.
- Make sure the latches on each side of the battery pack snap in place and that battery pack is secured in drill before beginning operation.

CAUTION: When placing battery pack in the tool, be sure raised rib on battery pack aligns with the bottom of the drill and latches into place properly. Improper installation of the battery pack can cause damage to internal components.

TO REMOVE BATTERY PACK

See Figure 3.

- Lock switch trigger on the drill by placing the direction of rotation selector in center position.
- Locate latches on side of battery pack and depress both sides to release battery pack from the drill.
- Remove battery pack from the drill.

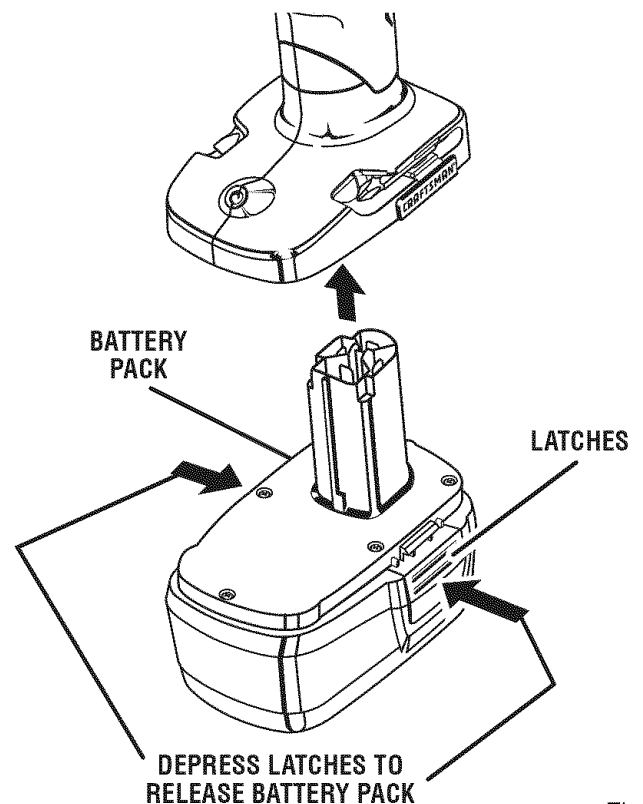

Fig. 3

OPERATION

WARNING: Battery tools are always in operating condition. Therefore, switch should always be locked when not in use or carrying at your side.

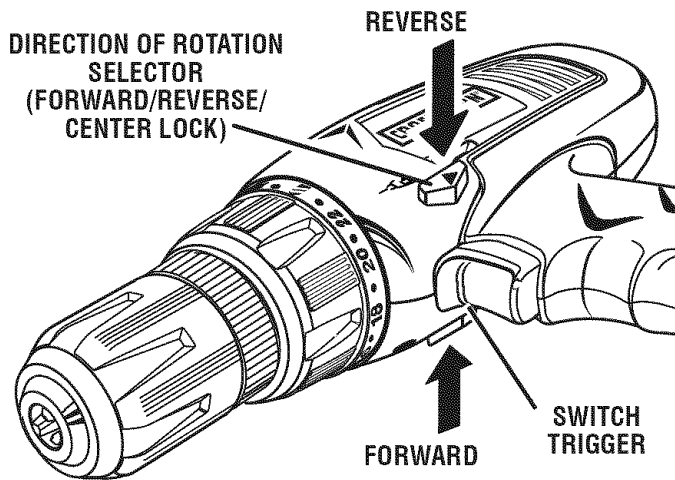

Fig. 4

SWITCH TRIGGER

See Figure 4.

To turn the drill **ON**, depress the switch trigger. To turn it **OFF**, release the switch trigger.

VARIABLE SPEED

The variable speed switch delivers higher speed and torque with increased trigger pressure and lower speed with decreased trigger pressure.

NOTE: You might hear a whistling or ringing noise from the switch during use. Do not be concerned; this is a normal part of the switch function.

DIRECTION OF ROTATION SELECTOR (FORWARD/REVERSE/CENTER LOCK)

See Figure 4.

The direction of bit rotation is reversible and is controlled by a selector located above the switch trigger. With the drill held in normal operating position, the direction of rotation selector should be positioned to the left of the switch trigger for drilling. The drilling direction is reversed when the selector is to the right of the switch trigger.

Setting the switch trigger in the **OFF** (center lock) position helps reduce the possibility of accidental starting when not in use.

CAUTION: To prevent gear damage, always allow the chuck to come to a complete stop before changing the direction of rotation.

To stop the drill, release the switch trigger and allow the chuck to come to a complete stop.

NOTE: The drill will not run unless the direction of rotation selector is pushed fully to the left or right.

Avoid running the drill at low speeds for extended periods of time. Running at low speeds under constant usage may cause the drill to become overheated. If this occurs, cool the drill by running it without a load and at full speed.

KEYLESS CHUCK

See Figure 5.

The drill has a keyless chuck to tighten or release drill bits in the chuck jaws. The arrows on the chuck indicate which direction to rotate the chuck body in order to **LOCK** (tighten) or **UNLOCK** (release) the drill bit.

WARNING: When the auto lock selector is set to drill mode, do not hold chuck body with one hand and use power of the drill to tighten chuck jaws on drill bit. Chuck body could slip in your hand or your hand could slip and come in contact with rotating drill bit. This could cause an accident resulting in serious personal injury.

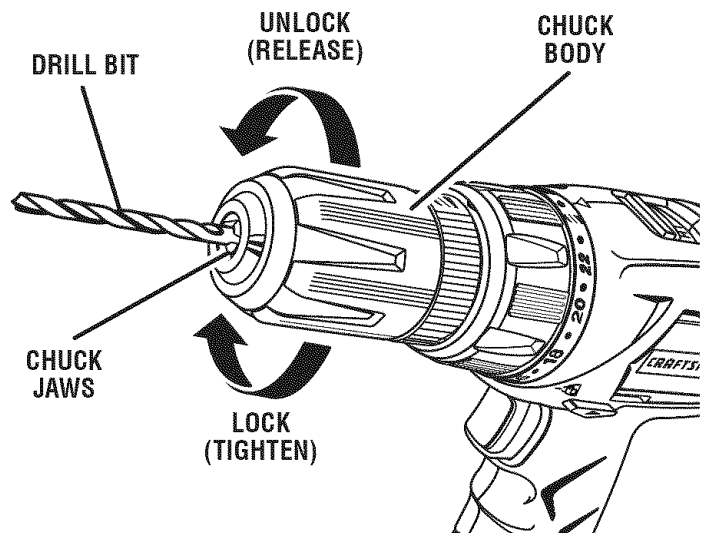

Fig. 5

OPERATION

AUTO LOCK CHUCK

See Figure 6.

Bits can be changed quickly using the auto lock chuck feature. In auto lock mode, the chuck jaws open when the direction of rotation selector is set for reverse rotation and the switch trigger is depressed. The chuck jaws close when the direction of rotation selector is set for forward rotation and the switch trigger is depressed.

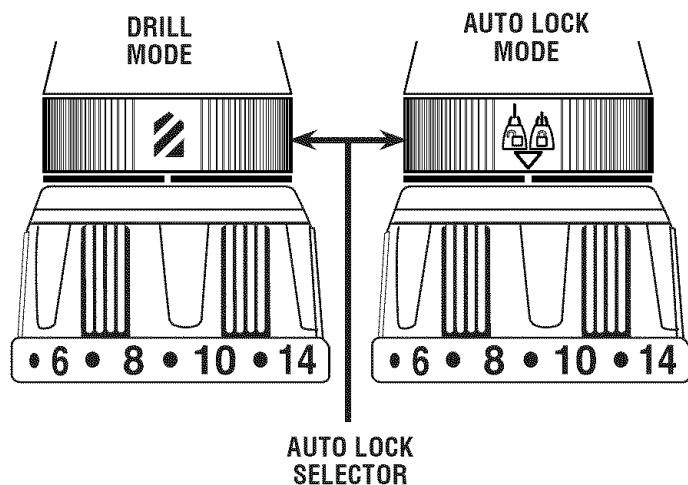

Fig. 6

TWO-SPEED GEAR TRAIN

See Figure 7.

The drill has a two-speed gear train designed for drilling or driving at **LO (1)** or **HI (2)** speeds. A slide switch is located on top of the drill to select either **LO (1)** or **HI (2)** speed. When using drill in the **LO (1)** speed range, speed will decrease and unit will have more power and torque. When using drill in the **HI (2)** speed range, speed will increase and unit will have less power and torque. Use **LO (1)** speed for high power and torque applications and **HI (2)** speed for fast drilling or driving applications.

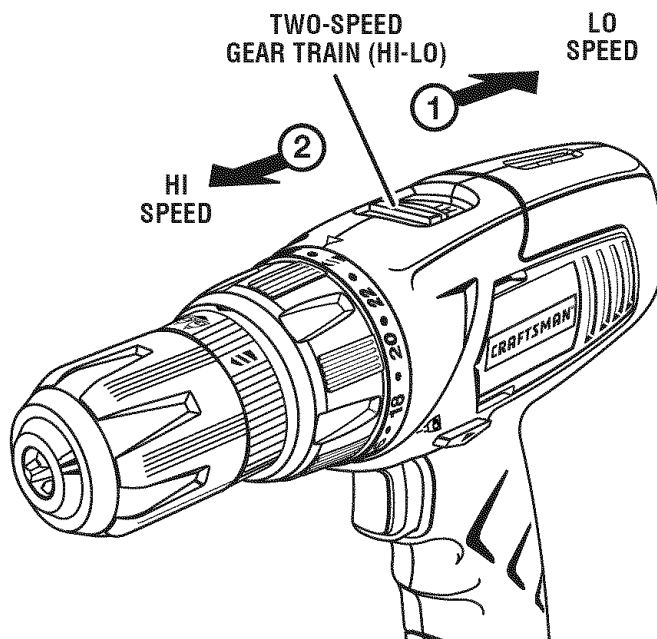

Fig. 7

OPERATION

ADJUSTABLE TORQUE CLUTCH

This product is equipped with an adjustable torque clutch for driving different types of screws into different materials. The proper setting depends on the type of material and the size of screw you are using.

ADJUSTING TORQUE

See Figure 8.

- There are twenty-four torque indicator settings located on the front of the drill.
- Rotate the adjusting ring to the desired setting.
 - 1 - 4 For driving small screws
 - 5 - 8 For driving screws into soft material
 - 9 - 12 For driving screws into soft and hard materials
 - 13 - 16 For driving screws into hard wood
 - 17 - 23 For driving large screws
 -  For heavy drilling

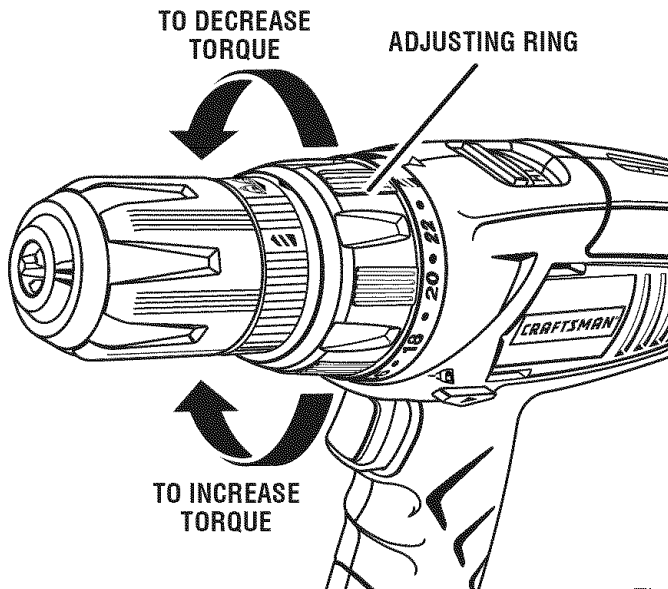

Fig. 8

LED WORKLIGHT

See Figure 9.

The LED worklight on the foot of the drill will come on when the switch trigger is depressed. This provides additional lighting on the surface of the workpiece for operation in lower-light areas.

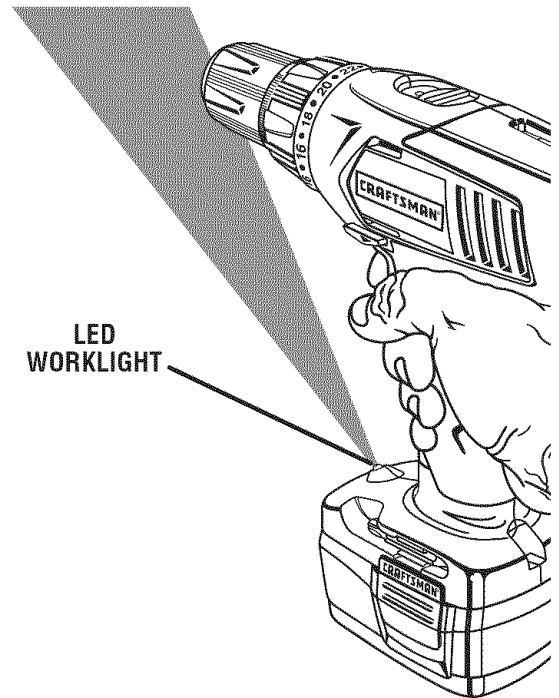

Fig. 9

BIT STORAGE

See Figure 10.

When not in use, bits provided with the drill can be placed in the storage area located on the base of the drill.

SCREWDRIVER BIT(S)

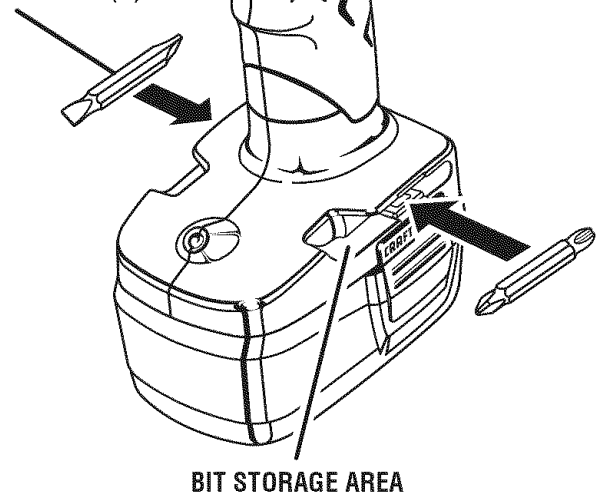

Fig. 10

OPERATION

INSTALLING AND REMOVING BITS

There are two methods for installing and removing bits. You can choose the auto lock feature to quickly open and close the chuck jaws, or you can use the keyless chuck.

USING THE AUTO LOCK FEATURE TO INSTALL BITS

See Figures 11 - 12.

- Turn the auto lock selector to auto lock mode.
- Push the direction of rotation selector to the left (reverse).
- Set the two-speed gear train to the **HI (2)** setting.
- Fully depress the switch trigger slowly to start the drill. The chuck jaws will open. The opening should be slightly larger than the drill bit you intend to use.
NOTE: Do not allow the chuck jaws to open all the way and ratchet.
- Tilt the drill so that the bit will not fall out when it is inserted into the open chuck jaws.
NOTE: Do not point the drill toward yourself or others.
- Insert the bit.
- Push the direction of rotation selector to the right (forward).

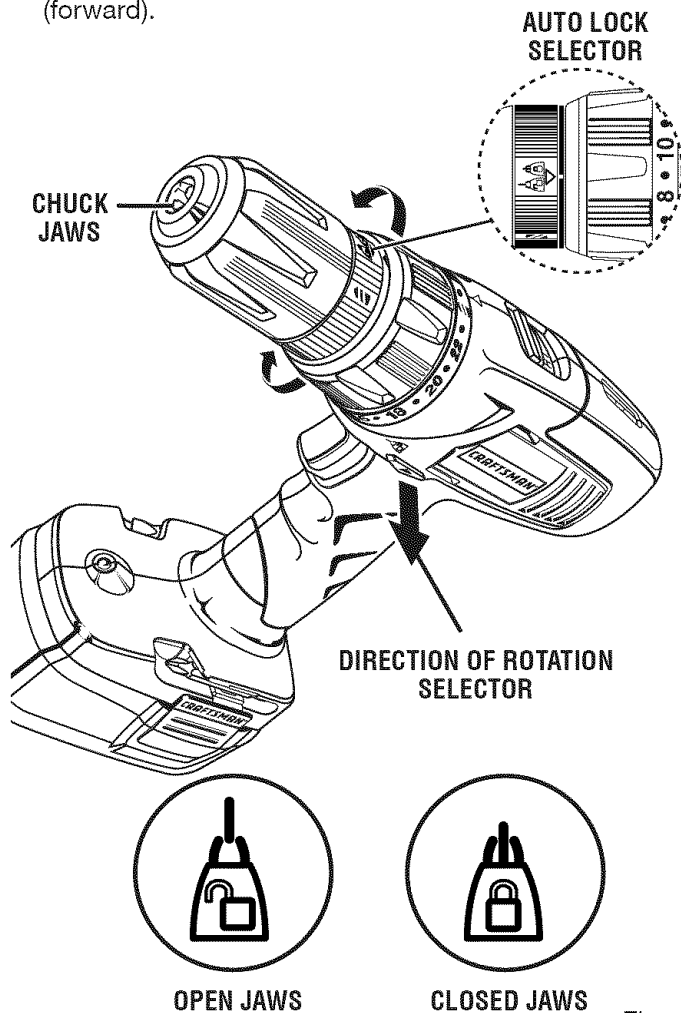

Fig. 11

- Fully depress the switch trigger to tighten the chuck jaws on the drill bit.
NOTE: You will hear a ratcheting sound when the jaws are closed around the bit and cannot be tightened further. Allow the drill to impact for approximately 3 seconds to securely tighten the bit in the chuck jaws.
NOTE: Do not allow the chuck jaws to close on themselves. Always tighten the chuck jaws with a bit inserted in the drill.

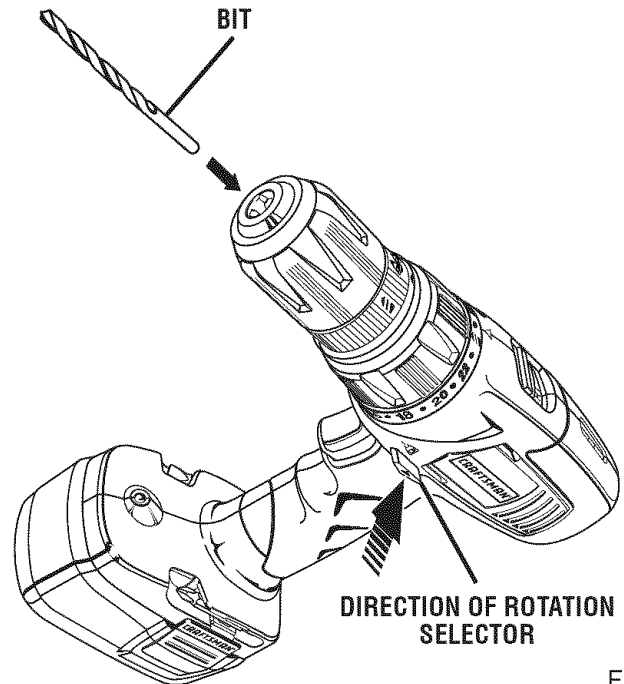

Fig. 12

- ⚠ **WARNING:** Do not touch the bit while the chuck is rotating. Doing so could cause serious personal injury.
- ⚠ **WARNING:** Make sure the chuck jaws are securely tightened and the drill bit is straight before operation. Using a bit that is not properly tightened may result in serious personal injury.

- Turn the auto lock selector to drill mode before performing a drilling operation.

USING THE AUTO LOCK FEATURE TO REMOVE BITS

- Turn the auto lock selector to auto lock mode.
- Push the direction of rotation selector to the left (reverse).
- Set the two-speed gear train to the **HI (2)** setting.
- Depress the switch trigger slowly to start the drill. The chuck jaws will open.
NOTE: Do not allow the chuck jaws to open all the way and ratchet.
- Remove the bit.

OPERATION

INSTALLING BITS USING THE KEYLESS CHUCK

See Figures 13 - 14.

- Lock the switch trigger by placing the direction of rotation selector in the center position.
- Turn the auto lock selector to drill mode.
- Open or close the chuck jaws to a point where the opening is slightly larger than the bit size you intend to use. Also, raise the front of the drill slightly to keep the bit from falling out of the chuck jaws.
- Insert the drill bit.
- Tighten the chuck jaws on the drill bit.

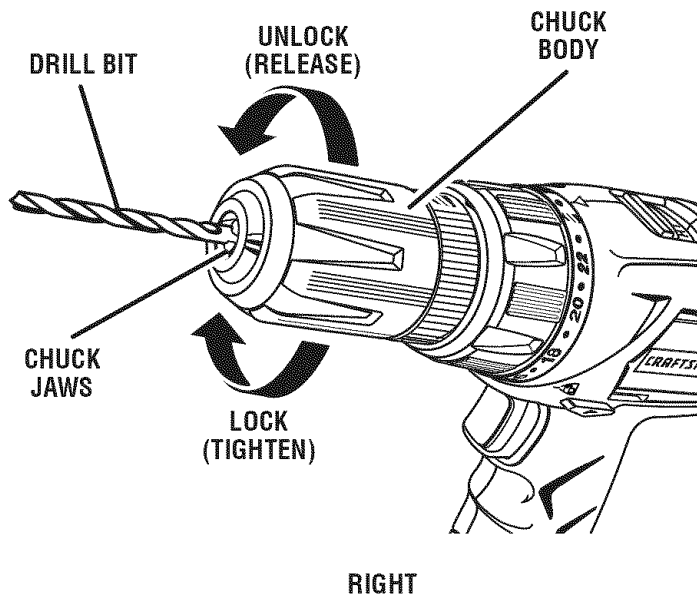

Fig. 13

WARNING: Make sure to insert the drill bit straight into the chuck jaws. Do not insert the drill bit into the chuck jaws at an angle then tighten, as shown in figure 14. This could cause the drill bit to be thrown from the drill, resulting in possible serious personal injury or damage to the chuck.

- Rotate the chuck clockwise to tighten the chuck jaws securely on the bit.

NOTE: Rotate the chuck body in the direction of the arrow marked **LOCK** to tighten the chuck jaws. Do not use a wrench to tighten or loosen the chuck jaws.

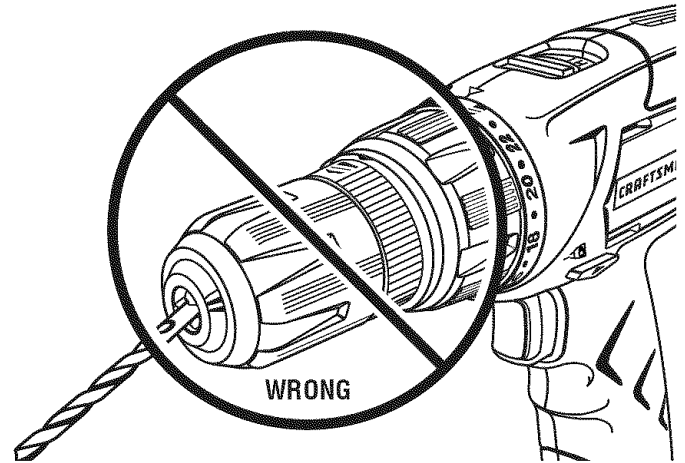

Fig. 14

REMOVING BITS USING THE KEYLESS CHUCK

- Lock the switch trigger by placing the direction of rotation selector in the center position.
 - Rotate the chuck sleeve clockwise to open the chuck jaws.
- NOTE:** Rotate the chuck body in the direction of the arrow marked **UNLOCK** to loosen the chuck jaws. Do not use a wrench to tighten or loosen the chuck jaws.
- Remove the drill bit.

OPERATION

⚠ WARNING: Make sure the chuck jaws are securely tightened on the drill bit before changing the auto lock selector from auto lock mode to drill mode.

DRILLING

See Figures 15 - 16.

Levels are located on the top and end of the motor housing to help keep the drill bit level during use.

- Check the direction of rotation selector for the correct setting (forward or reverse).
- Check the auto lock selector to ensure it is set to drill mode.
- Secure the material to be drilled in a vise or with clamps to keep it from turning as the drill bit rotates.
- Hold the drill firmly and place the bit at the point to be drilled.
- Depress the switch trigger to start the drill.
- Move the drill bit into the workpiece, applying only enough pressure to keep the bit cutting. Do not force the drill or apply side pressure to elongate a hole. Let the tool do the work.

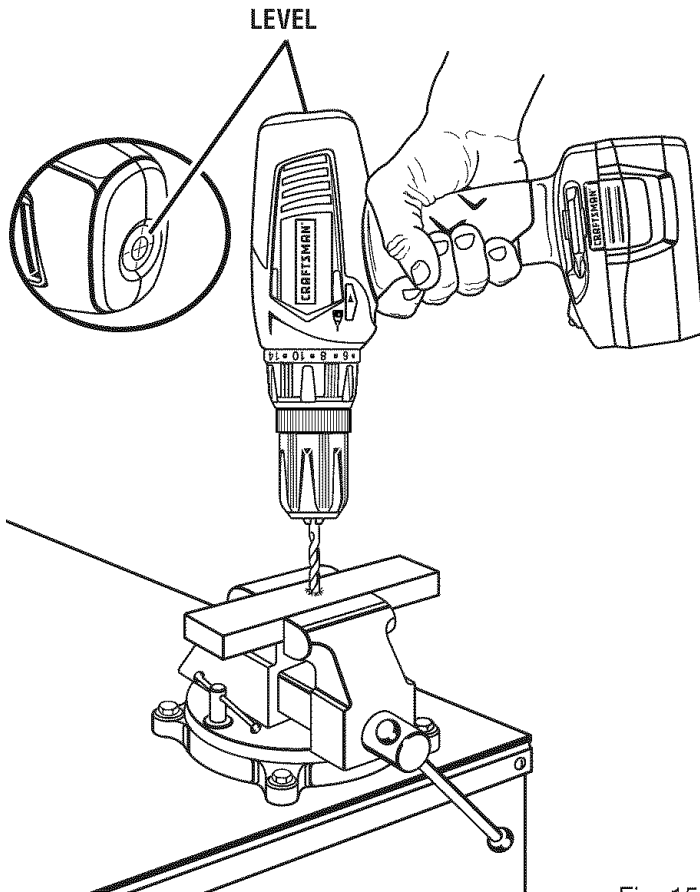

Fig. 15

⚠ WARNING: Be prepared for binding at bit breakthrough. When these situations occur, drill has a tendency to grab and kick opposite to the direction of rotation and could cause loss of control when breaking through material. If not prepared, this loss of control can result in possible serious injury.

- When drilling hard, smooth surfaces, use a center punch to mark the desired hole location. This will prevent the drill bit from slipping off-center as the hole is started.
- When drilling metals, use a light oil on the drill bit to keep it from overheating. The oil will prolong the life of the bit and increase the drilling action.
- If the bit jams in the workpiece or if the drill stalls, stop the tool immediately. Remove the bit from the workpiece and determine the reason for jamming.

NOTE: This drill has an electric brake. When the switch trigger is released, the chuck stops turning. When the brake is functioning properly, sparks will be visible through the vent slots on the housing. This is normal and is the action of the brake.

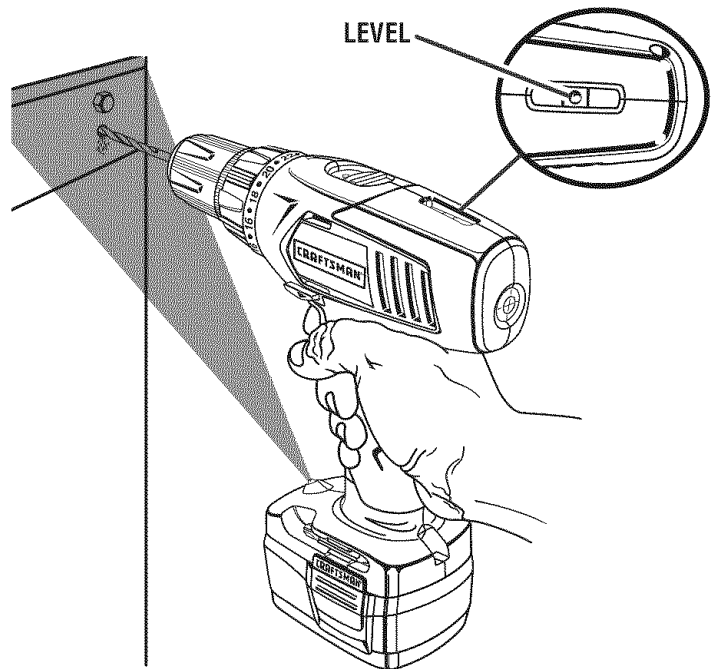

Fig. 16

MAINTENANCE

⚠ WARNING: When servicing, use only identical Craftsman replacement parts. Use of any other part may create a hazard or cause product damage.

⚠ WARNING: Always wear safety goggles or safety glasses with side shields when using compressed air to clean tools. If the operation is dusty, also wear a dust mask.

⚠ WARNING: To avoid serious personal injury, always remove the battery pack from the tool when cleaning or performing any maintenance.

GENERAL MAINTENANCE

Avoid using solvents when cleaning plastic parts. Most plastics are susceptible to damage from various types of commercial solvents and may be damaged by their use. Use clean cloths to remove dirt, dust, oil, grease, etc.

⚠ WARNING: Do not at any time let brake fluids, gasoline, petroleum-based products, penetrating oils, etc., come in contact with plastic parts. Chemicals can damage, weaken or destroy plastic which may result in serious personal injury.

Only the parts shown on the parts list are intended to be repaired or replaced by the customer. All other parts should be replaced at a Sears Service Center.

BATTERIES

The battery pack for this tool is equipped with nickel-cadmium rechargeable batteries. Length of service from each charging will depend on the type of work you are doing.

The batteries in this tool have been designed to provide maximum trouble-free life. However, like all batteries, they will eventually wear out. **Do not** disassemble battery pack and attempt to replace the batteries. Handling of these batteries, especially when wearing rings and jewelry, could result in a serious burn.

To obtain the longest possible battery life, we suggest the following:

- Remove the battery pack from the charger once it is fully charged and ready for use.

For battery pack storage longer than 30 days:

- Store the battery pack where the temperature is below 80°F.
- Store battery packs in a “discharged” condition.

BATTERY PACK REMOVAL AND PREPARATION FOR RECYCLING



To preserve natural resources, please recycle or dispose of batteries properly.

This product contains nickel-cadmium batteries. Local, state or federal laws may prohibit disposal of nickel-cadmium batteries in ordinary trash.

Consult your local waste authority for information regarding available recycling and/or disposal options.

⚠ WARNING: Upon removal, cover the battery pack's terminals with heavy-duty adhesive tape. Do not attempt to destroy or disassemble battery pack or remove any of its components. Nickel-cadmium batteries must be recycled or disposed of properly. Also, never touch both terminals with metal objects and/or body parts as short circuit may result. Keep away from children. Failure to comply with these warnings could result in fire and/or serious injury.

MAINTENANCE

CHUCK REMOVAL

See Figures 17 - 19.

The chuck may be removed and replaced by a new one.

- Lock the switch trigger by placing the direction of rotation selector in center position.
- Insert a 5/16 in. or larger hex key into the chuck of the drill and tighten the chuck jaws securely.
- Tap the hex key sharply with a mallet in a clockwise direction. This will loosen the screw in the chuck for easy removal.

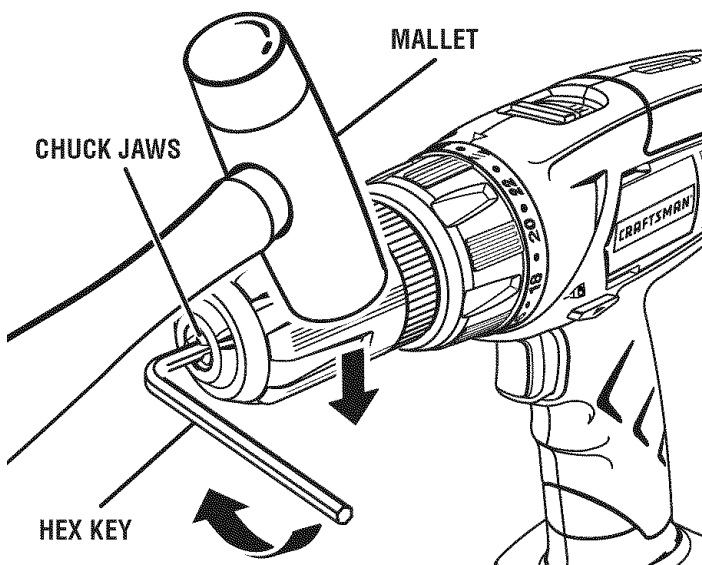

Fig. 17

- Open the chuck jaws and remove the hex key. Using a screwdriver, remove the chuck screw by turning it in a clockwise direction.

NOTE: The chuck screw has left hand threads.

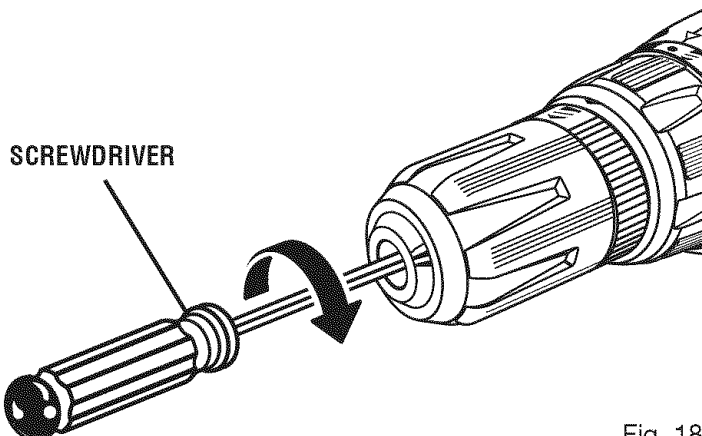

Fig. 18

- Insert the hex key into the chuck and tighten the chuck jaws securely. Tap sharply with a mallet in a counterclockwise direction. This will loosen the chuck on the spindle. It can now be unscrewed by hand.

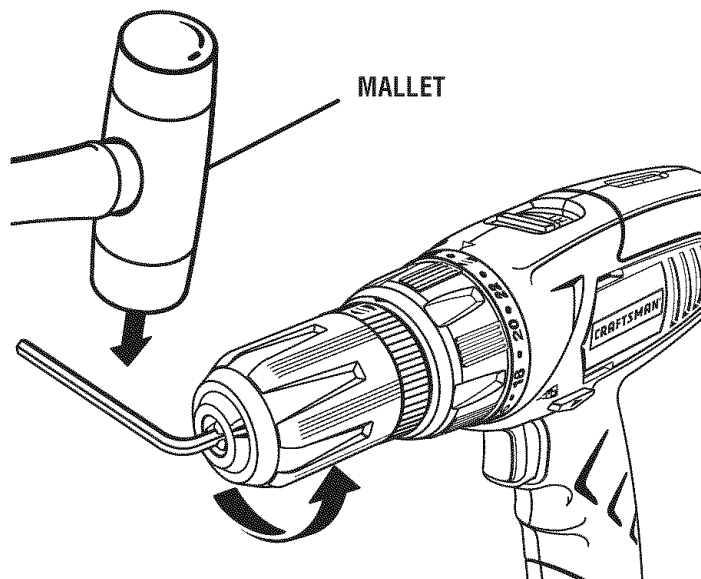

Fig. 19

TO RETIGHTEN A LOOSE CHUCK

The chuck may become loose on the spindle and develop a wobble. Also, the chuck screw may become loose, causing the chuck jaws to bind and prevent them from closing. To tighten:

- Lock the switch trigger by placing the direction of rotation selector in the center position.
- Open the chuck jaws.
- Insert the hex key into the chuck and tighten the chuck jaws securely. Tap the hex key sharply with a mallet in a clockwise direction. This will tighten the chuck on the spindle.
- Open the chuck jaws and remove the hex key.
- Tighten the chuck screw.

CRAFTSMAN 14.4 VOLT CORDLESS DRILL MODEL NO. 315.115470

The model number will be found on a plate attached to the motor housing. Always mention the model number in all correspondence regarding your **CORDLESS DRILL-DRIVER** or when ordering repair parts.

SEE BACK PAGE FOR PARTS ORDERING INSTRUCTIONS

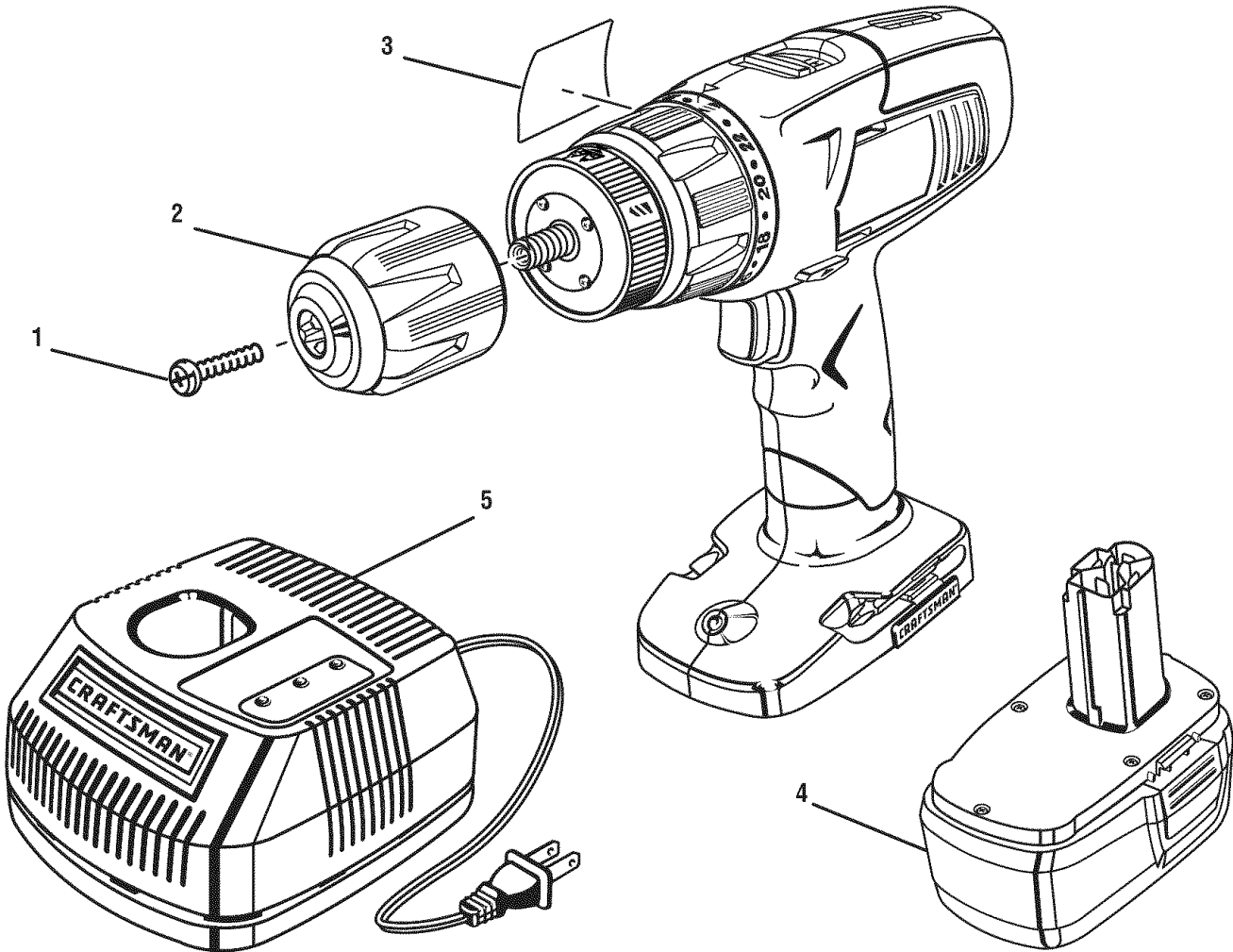

PARTS LIST

Key No.	Part Number	Description	Qty.
1	6613402	Screw	1
2	690033067	Chuck	1
3	940237105	Data Plate	1
4	130279002	* Battery Pack (Item No. 9 11044).....	2
5	1425301	* Charger (Item No. 9 11041)	1
	300912263	Case (not shown).....	1
	983000843	Operator's Manual (not shown)	

* Can Be Purchased Thru RSOS (Retail Special Order System)