

Micro HI-FI Component System

Operating Instructions

2-663-704-12(1)

GB

Owner's Record

The model and serial numbers are located on the rear of the unit. Record these numbers in the space provided below. Refer to them whenever you call upon your Sony dealer regarding this product.
Model No. _____ Serial No. _____

CMT-NEZ50/NEZ33/ NEZ30

© 2006 Sony Corporation Printed in China
http://www.sony.net/



Printed on 100% recycled paper using VOC (Volatile Organic Compound)-free vegetable oil based ink.

WARNING

To reduce the risk of fire or electric shock, do not expose this apparatus to rain or moisture.

To reduce the risk of fire, do not cover the ventilation of the apparatus with newspapers, tablecloths, curtains, etc. And do not place lighted candles on the apparatus.

To reduce the risk of fire or electric shock, do not place objects filled with liquids, such as vases, on the apparatus.

Connect the unit to an easily accessible AC outlet. Should you notice an abnormality in the unit, disconnect the main plug from the AC outlet immediately.

Do not install the appliance in a confined space, such as a bookcase or built-in cabinet.

CAUTION

The use of optical instruments with this product will increase eye hazard.

Except for customers in the U.S.A. and Canada

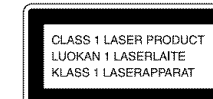

This appliance is classified as a CLASS 1 LASER product. This marking is located on the rear exterior.

Notice for the customers in the U.S.A.

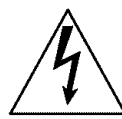
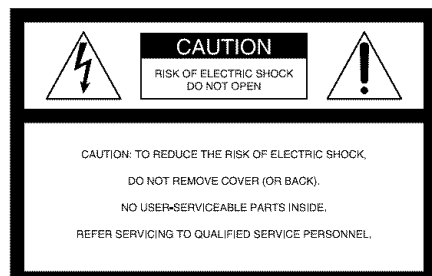

This symbol is intended to alert the user to the presence of uninsulated "dangerous voltage" within the product's enclosure that may be of sufficient magnitude to constitute a risk of electric shock to persons.



This symbol is intended to alert the user to the presence of important operating and maintenance (servicing) instructions in the literature accompanying the appliance.

WARNING

This equipment has been tested and found to comply with the limits for a Class B digital device, pursuant to Part 15 of the FCC Rules. These limits are designed to provide reasonable protection against harmful interference in a residential installation. This equipment generates, uses, and can radiate radio frequency energy and, if not installed and used in accordance with the instructions, may cause harmful interference to radio communications. However, there is no guarantee that interference will not occur in a particular installation. If this equipment does cause harmful interference to radio or television reception, which can be determined by turning the equipment off and on, the user is encouraged to try to correct the interference by one or more of the following measures:

- Reorient or relocate the receiving antenna.
- Increase the separation between the equipment and receiver.
- Connect the equipment into an outlet on a circuit different from that to which the receiver is connected.
- Consult the dealer or an experienced radio/TV technician for help.

This device complies with Part 15 of the FCC Rules. Operation is subject to the following two conditions: (1) This device may not cause harmful interference, and (2) this device must accept any interference received, including interference that may cause undesired operation.

You are cautioned that any changes or modifications not expressly approved in this manual could void your authority to operate this equipment.

Note to CATV system installer:

This reminder is provided to call the CATV system installer's attention to Article 820-40 of the NEC that provides guidelines for proper grounding and, in particular, specifies that the cable ground shall be connected to the grounding system of the building, as close to the point of cable entry as practical.



Disposal of Old Electrical & Electronic Equipment (Applicable in the European Union and other European countries with separate collection systems)

This symbol on the product or on its packaging indicates that this product shall not be treated as household waste. Instead it shall be handed over to the applicable collection point for the recycling of electrical and electronic equipment. By ensuring this product is disposed of correctly, you will help prevent potential negative consequences for the environment and human health, which could otherwise be caused by inappropriate waste handling of this product. The recycling of materials will help to conserve natural resources. For more detailed information about recycling of this product, please contact your local Civic Office, your household waste disposal service or the shop where you purchased the product.
Applicable accessories: Remote commander

U.S.A., Canadian and Australian models only



ENERGY STAR® is a U.S. registered mark. As an ENERGY STAR® partner, Sony Corporation has determined that this product meets the ENERGY STAR® guidelines for energy efficiency.

Note on DualDiscs

A DualDisc is a two sided disc product which mates DVD recorded material on one side with digital audio material on the other side. However, since the audio material side does not conform to the Compact Disc (CD) standard, playback on this product is not guaranteed.

Music discs encoded with copyright protection technologies

This product is designed to playback discs that conform to the Compact Disc (CD) standard. Recently, various music discs encoded with copyright protection technologies are marketed by some record companies. Please be aware that among those discs, there are some that do not conform to the CD standard and may not be playable by this product.

MPEG Layer-3 audio coding technology and patents licensed from Fraunhofer IIS and Thomson.

Basic Operations

CMT-NEZ50

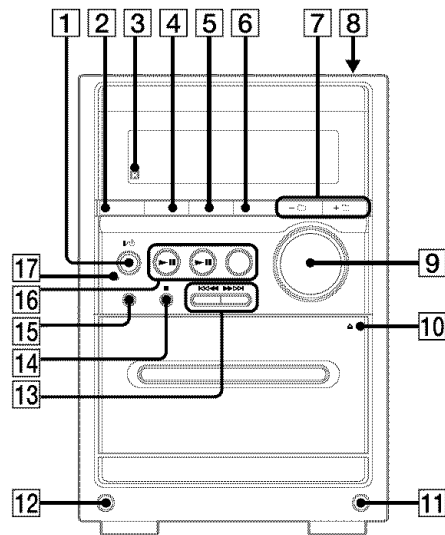

CMT-NEZ33/NEZ30

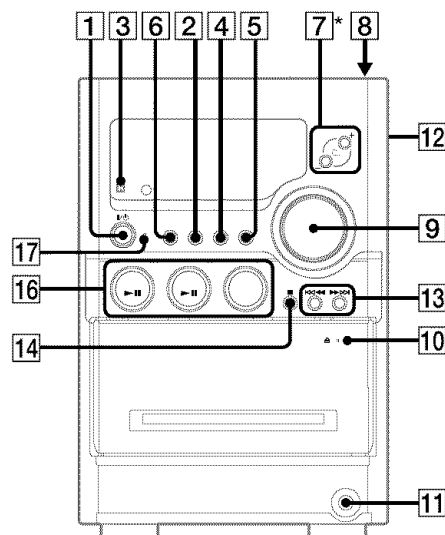

*Except for the North American model

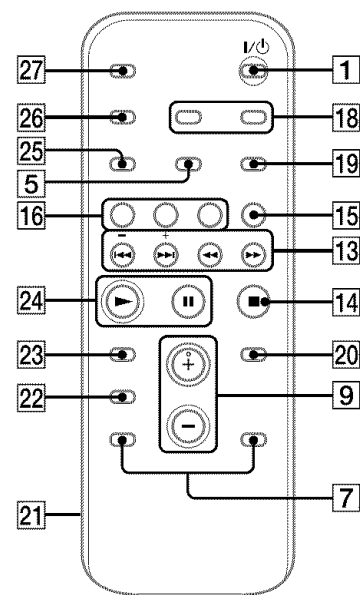

Selecting a music source

Press the following buttons (or press FUNCTION **16** repeatedly).

To select	Press
CD	CD 16 on the remote.
Tuner	TUNER/BAND 16 .
Tape	TAPE 16 on the remote.
Component (connected using an audio cord)	FUNCTION 16 repeatedly until "AUDIO IN" appears.

Adjusting the sound

To adjust the volume

Press VOLUME +/- on the remote (or turn the VOLUME control on the unit) **9**.

To add a sound effect

To	Press
Generate a more dynamic sound (Dynamic Sound Generator X-tra)	DSGX 16 on the unit.
Set the sound effect	EQ 22 on the remote repeatedly to select "BASS" or "TREBLE," and then press 14 and 13 repeatedly to adjust the level.

Playing a CD/MP3 disc

- Select the CD function.
Press CD **16** on the remote.
- Place a disc.
Press **▲** PUSH OPEN/CLOSE **10** on the unit, and place a disc with the label side up on the CD compartment.
To close the CD compartment, press **▲** PUSH OPEN/CLOSE **10** on the unit.
- Start playback.
Press **▶** (play) **24** on the remote (or CD/▶ **16** (play/pause) **16** on the unit).

To	Press
Pause playback	 (pause) 24 on the remote (or CD/▶ 16 (play/pause) 16 on the unit). To resume play, press the button again.
Stop playback	■ (stop) 14 .
Select a folder on an MP3 disc	⏪ +/- (select folder) 7 .
Select a track or file	⏪ / ▶ (go back/go forward) 13 .
Find a point in a track or file	Hold down ⏪ / ▶ (rewind/fast forward) 13 during playback, and release the button at the desired point.
Select Repeat Play	REPEAT 19 on the remote repeatedly until "REPEAT" or "REPEAT 1" appears.

Before using the system

To use the remote

Slide and remove the battery compartment lid **21**, and insert the two supplied R6 (size AA) batteries, **⊖** side first, matching the polarities shown below.

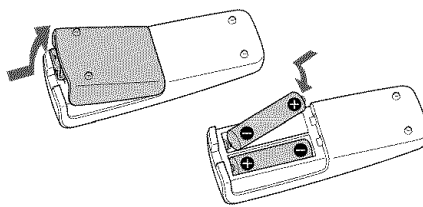

Notes on using the remote

- With normal use, the batteries should last for about six months.
- Do not mix an old battery with a new one or mix different types of batteries.
- If you do not use the remote for a long period of time, remove the batteries to avoid damage from battery leakage and corrosion.

To set the clock

- Turn on the system.
Press I/O (power) **1**.
- Select the clock set mode.
Press CLOCK/TIMER SET **18** on the remote. If the current mode appears on the display, press **⏪** / **▶** **13** on the remote repeatedly to select "CLOCK" and then press ENTER **20** on the remote.
- Set the time.
Press **⏪** / **▶** **13** on the remote repeatedly to set the hour, and then press ENTER **20** on the remote. Use the same procedure to set the minute.
The clock settings are lost when you disconnect the power cord or if a power failure occurs.

To change the play mode

Press PLAY MODE **5** repeatedly while the player is stopped. You can select normal play ("▶") for all MP3 files in the folder on the disc, shuffle play ("SHUF"*) or "SHUF6"**, or program play ("PGM").

*When playing a CD-DA disc, (SHUF) Play performs the same operation as normal (SHUF) Play.

Notes on Repeat Play

- All tracks or files on a disc are played repeatedly up to five times.
- "REPEAT 1" indicates that a single track or file is repeated until you stop it.

Notes on playing MP3 discs

- Do not save other types of files or unnecessary folders on a disc that has MP3 files.
- Folders that have no MP3 files are skipped.
- MP3 files are played back in the order that they are recorded onto the disc.
- The system can only play MP3 files that have a file extension of ".MP3."
- If there are files on the disc that have the ".MP3" file extension, but that are not MP3 files, the unit may produce noise or may malfunction.
- The maximum number of:
 - folders is 150 (including the root folder).
 - MP3 files is 255.
 - MP3 files and folders that can be contained on a single disc is 256.
 - folder levels (the tree structure of files) is 8.
- Compatibility with all MP3 encoding/writing software, recording device, and recording media cannot be guaranteed. Incompatible MP3 discs may produce noise or interrupted audio or may not play at all.

Notes on playing multisession discs

- If the disc begins with a CD-DA (or MP3) session, it is recognized as a CD-DA (or MP3) disc, and playback continues until another session is encountered.
- A disc with a mixed CD format is recognized as a CD-DA (audio) disc.

Listening to the radio

- Select "FM" or "AM."
Press TUNER/BAND **16** repeatedly.
- Select the tuning mode.
Press TUNING MODE **5** repeatedly until "AUTO" appears.
- Tune in the desired station.
Press +/- on the remote (or TUNING +/- on the unit) **13**. Scanning stops automatically when a station is tuned in, and then "TUNED" and "STEREO" (for stereo programs) appear. When you tune in a station that provides RDS services, the station name appears on the display (European model only).

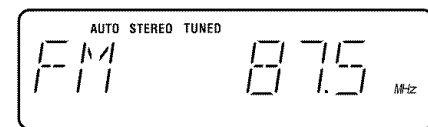

To stop automatic scanning

Press **■** (stop) **14**.

To tune in a station with a weak signal

If "TUNED" does not appear and the scanning does not stop, press TUNING MODE **5** repeatedly until "AUTO" and "PRESET" disappear, and then press +/- on the remote (or TUNING +/- on the unit) **13** repeatedly to tune in the desired station.

To reduce static noise on a weak FM stereo station

Press FM MODE **19** on the remote repeatedly until "STEREO" disappears to turn off stereo reception.

Playing a tape

- Select the tape function.
Press TAPE **16** on the remote.
- Insert a tape.
Press PUSH OPEN/CLOSE **▲** **10** on the unit, and insert the TYPE I (normal) tape into the cassette holder with the side you want to play facing forward. Make sure there is no slack in the tape to avoid damaging the tape or the tape deck. Press PUSH OPEN/CLOSE **▲** **10** on the unit again to close the cassette holder.
- Start playback.
Press **▶** (play) **24** on the remote (or TAPE/▶ **16** (play/pause) **16** on the unit).

To	Press
Pause playback	 (pause) 24 on the remote (or TAPE/▶ 16 (play/pause) 16 on the unit). To resume play, press the button again.
Stop playback	■ (stop) 14 .
Rewind or fast forward	⏪ / ▶ (rewind/fast forward) 13 .

Changing the display

To change	Press
Information on the display*	DISPLAY 26 on the remote repeatedly when the system is on.
Display mode (See below.)	DISPLAY 26 on the remote repeatedly when the system is off.

*For example, you can view CD/MP3 disc information, such as the track or file number or folder name during normal play, or the total play time while the player is stopped.

The system offers the following display modes.

Display mode	When the system is off, ¹⁾
Clock	The clock is displayed.
Power Saving Mode ²⁾	The display is turned off to conserve power. The timer and clock continue to operate.

¹⁾The STANDBY indicator lights up when the system is off.

²⁾When the system is in Power Saving Mode, the following functions are unavailable:

- setting the clock.
- changing the AM tuning interval
- changing the CD power management function

Notes on the display information

- The following are not displayed:
 - total playing time for a CD-DA disc depending on the play mode.
 - total playing time for an MP3 disc.
 - remaining playing time for an MP3 file.
- The following are not displayed correctly:
 - elapsed playing time of an MP3 file encoded using a VBR (variable bit rate).
 - folder and file names that do not follow either the ISO9660 Level 1, Level 2 or Joliet in the expansion format.
- The following are displayed:
 - ID3 tag information for MP3 files when ID3 version 1 and version 2 tags are used.
 - up to 30 characters of ID3 tag information using uppercase letters (A to Z), numbers (0 to 9), and symbols (" \$ % ' () + , - / < = > @ [\] _ { | }).

Hooking up the system securely

