

Save This Manual
For Future Reference

Sears

*owners
manual*

MODEL NO.

113.298142

SAW ONLY

113.298032

SAW WITH LEGS
TWO TABLE EXTENSIONS
AND MOTOR

113.298240

SAW WITH LEGS
TWO TABLE EXTENSIONS
MOTOR AND HOLD DOWN

Serial
Number _____

Model and serial
number may be found
at the left-hand side
of the base.

You should record both
model and serial number
in a safe place for
future use.

CAUTION:

Read **GENERAL**
and **ADDITIONAL**
SAFETY
INSTRUCTIONS
carefully

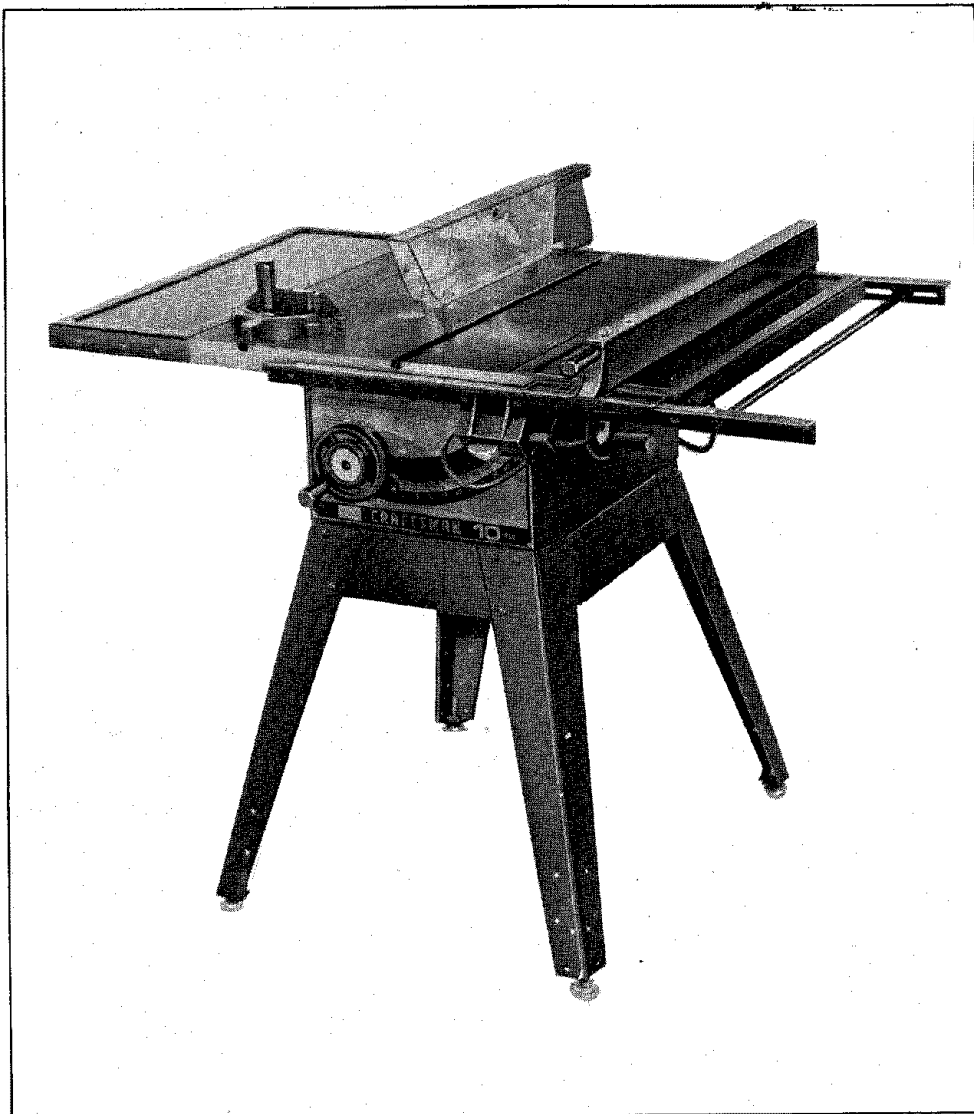

Sears **CRAFTSMAN**

10-INCH TABLE SAW

- *assembly*
- *operating*
- *repair parts*

Sold by SEARS, ROEBUCK AND CO., Chicago, IL. 60684 U.S.A.

FULL ONE YEAR WARRANTY ON CRAFTSMAN TABLE SAW

If within one year from the date of purchase, this Craftsman Table Saw fails due to a defect in material or workmanship, Sears will repair it, free of charge. This warranty applies only while this product is in use in the United States.

WARRANTY SERVICE IS AVAILABLE BY SIMPLY CONTACTING THE NEAREST SEARS SERVICE CENTER/DEPARTMENT THROUGHOUT THE UNITED STATES.

This warranty gives you specific legal rights, and you may also have other rights which vary from state to state.

SEARS, ROEBUCK AND CO., Dept. 698/731A, Sears Tower, Chicago, IL 60684

GENERAL SAFETY INSTRUCTIONS FOR POWER TOOLS

1. KNOW YOUR POWER TOOL

Read and understand the owner's manual and labels affixed to the tool. Learn its application and limitations as well as the specific potential hazards peculiar to this tool.

2. GROUND ALL TOOLS

This tool is equipped with an approved 3-conductor cord and a 3-prong grounding type plug to fit the proper grounding type receptacle. The green conductor in the cord is the grounding wire. Never connect the green wire to a live terminal.

3. KEEP GUARDS IN PLACE

in working order, and in proper adjustment and alignment.

4. REMOVE ADJUSTING KEYS AND WRENCHES

Form habit of checking to see that keys and adjusting wrenches are removed from tool before turning it on.

5. KEEP WORK AREA CLEAN

Cluttered areas and benches invite accidents. Floor must not be slippery due to wax or sawdust.

6. AVOID DANGEROUS ENVIRONMENT

Don't use power tools in damp or wet locations or expose them to rain. Keep work area well lighted. Provide adequate surrounding work space.

7. KEEP CHILDREN AWAY

All visitors should be kept a safe distance from work area.

8. MAKE WORKSHOP KID-PROOF

— with padlocks, master switches, or by removing starter keys.

9. DON'T FORCE TOOL

It will do the job better and safer at the rate for which it was designed.

10. USE RIGHT TOOL

Don't force tool or attachment to do a job it was not designed for.

11. WEAR PROPER APPAREL

Do not wear loose clothing, gloves, neckties or jewelry (rings, wrist watches) to get caught in moving parts. Nonslip footwear is recommended. Wear protective hair covering to contain long hair. Roll long sleeves above the elbow.

12. USE SAFETY GOGGLES (Head Protection)

Wear Safety goggles (must comply with ANSI Z87.1) at all times. Everyday eyeglasses only have impact resistant lenses, they are NOT safety glasses. Also, use face or dust mask if cutting operation is dusty, and ear

protectors (plugs or muffs) during extended periods of operation.

13. SECURE WORK

Use clamps or a vise to hold work when practical. It's safer than using your hand, frees both hands to operate tool.

14. DON'T OVERREACH

Keep proper footing and balance at all times.

15. MAINTAIN TOOLS WITH CARE

Keep tools sharp and clean for best and safest performance. Follow instructions for lubricating and changing accessories.

16. DISCONNECT TOOLS

before servicing; when changing accessories such as blades, bits, cutters, etc.

17. AVOID ACCIDENTAL STARTING

Make sure switch is in "OFF" position before plugging in.

18. USE RECOMMENDED ACCESSORIES

Consult the owner's manual for recommended accessories. Follow the instructions that accompany the accessories. The use of improper accessories may cause hazards.

19. NEVER STAND ON TOOL

Serious injury could occur if the tool is tipped or if the cutting tool is accidentally contacted.

Do not store materials above or near the tool such that it is necessary to stand on the tool to reach them.

20. CHECK DAMAGED PARTS

Before further use of the tool, a guard or other part that is damaged should be carefully checked to ensure that it will operate properly and perform its intended function. Check for alignment of moving parts, binding of moving parts, breakage of parts, mounting, and any other conditions that may affect its operation. A guard or other part that is damaged should be properly repaired or replaced.

21. DIRECTION OF FEED

Feed work into a blade or cutter against the direction of rotation of the blade or cutter only.

22. NEVER LEAVE TOOL RUNNING UNATTENDED

Turn power off. Don't leave tool until it comes to a complete stop.

ADDITIONAL SAFETY INSTRUCTIONS FOR TABLE SAWS

WARNING: FOR YOUR OWN SAFETY, DO NOT OPERATE YOUR SAW UNTIL IT IS COMPLETELY ASSEMBLED AND INSTALLED ACCORDING TO THE INSTRUCTIONS... AND UNTIL YOU HAVE READ AND UNDERSTAND THE FOLLOWING.

1. GENERAL SAFETY INSTRUCTIONS FOR POWER TOOLS... SEE PAGE 2
2. GETTING TO KNOW YOUR SAW... SEE PAGE 20
3. BASIC SAW OPERATION... SEE PAGE 23
4. ADJUSTMENTS... SEE PAGE 29
5. MAINTENANCE... SEE PAGE 34
6. STABILITY OF SAW

If there is any tendency for the saw to tip over or move during certain cutting operations such as cutting extremely large heavy panels or long heavy boards, the saw should be bolted down.

If you attach any kind of table extensions over 24" wide to either end of the saw, make sure you either bolt the saw to the bench or floor as appropriate, or support the outer end of the extension from the bench or floor, as appropriate.

7. LOCATION

The saw should be positioned so neither the operator nor a casual observer is forced to stand in line with the saw blade.

8. KICKBACKS

A "KICKBACK" occurs during a rip-type operation when a part or all of the workpiece is thrown back violently toward the operator.

Keep your face and body to one side of the sawblade, out of line with a possible "Kickback."

Kickbacks — and possible injury from them — can usually be avoided by:

- A. Maintaining the rip fence parallel to the sawblade.
- B. Keeping the sawblade sharp. Replace or sharpen antikickback pawls when points become dull.
- C. Keeping sawblade guard, spreader, and antikickback pawls in place and operating properly. The spreader must be in alignment with the sawblade and the pawls must stop a kickback once it has started. Check their action before ripping.
- D. NOT ripping work that is twisted or warped or does not have a straight edge to guide along the rip fence.
- E. NOT releasing work until you have pushed it all the way past the sawblade.
- F. Using a push stick for ripping widths of 2 to 6 in., and an auxiliary fence and push block for ripping widths narrower than 2 in. (See "Basic Saw Operation Using The Rip Fence" section.)
- G. NOT confining the cut-off piece when ripping or cross-cutting.
- H. When ripping apply the feed force to the section of the workpiece between the saw blade and the rip fence.

9. PROTECTION: EYES, HANDS, FACE, EARS, BODY

- A. If any part of your saw is malfunctioning, has been damaged or broken... such as the motor switch, or other operating control, a safety device or the power cord... cease operating immediately until the particular part is properly repaired or replaced.
- B. Wear safety goggles that comply with ANSI Z87.1, and a face shield if operation is dusty. Wear ear plugs or muffs during extended periods of operation.
- C. Small loose pieces of wood or other objects that contact the rear of the revolving blade can be thrown back at the operator at excessive speed. This can usually be avoided by keeping the guard and spreader in place for all thru-sawing operations

(sawing entirely thru the work) AND by removing all loose pieces from the table with a long stick of wood IMMEDIATELY after they are cut off.

- D. Use extra caution when the guard assembly is removed for resawing, dadoing, rabbeting, or molding — replace the guard as soon as that operation is completed.
- E. For rip or rip-type cuts, the following end of a workpiece to which a push stick or push board is applied must be square (perpendicular to the fence) in order that feed pressure applied to the workpiece by the push stick or block does not cause the workpiece to come away from the fence, and possibly cause a kickback.
- F. During rip and rip type cuts, the workpiece must be held down on the table and against the fence with a push stick, push block, or featherboards. A featherboard is made of solid lumber per sketch.

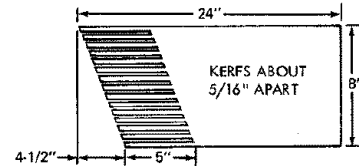

- G. NEVER turn the saw "ON" before clearing the table of all tools, wood scraps, etc., except the workpiece and related feed or support devices for the operation planned.
- H. NEVER place your face or body in line with the cutting tool.
- I. NEVER place your fingers or hands in the path of the sawblade or other cutting tool.
- J. NEVER reach in back of the cutting tool with either hand to hold down or support the workpiece, remove wood scraps, or for any other reason. Avoid awkward operations and hand positions where a sudden slip could cause fingers or hand to move into a sawblade or other cutting tool.
- K. DO NOT perform layout, assembly, or setup work on the table while the cutting tool is rotating.
- L. DO NOT perform any operation "FREEHAND" — always use either the rip fence or the miter gauge to position and guide the work.
- M. NEVER use the rip fence when crosscutting or the miter gauge when ripping. DO NOT use the rip fence as a length stop. Never hold onto or touch the "free end" of the workpiece or a "free piece" that is cut off, while power is "ON" and/or the sawblade is rotating.
- N. Shut "OFF" the saw and disconnect the power cord when removing the table insert, changing the cutting tool, removing or replacing the blade guard, or making adjustments.
- O. Provide adequate support to the rear and sides of the saw table for wider or long workpieces.
- P. Plastic and composition (like hardboard) materials may be cut on your saw. However, since these are usually quite hard and slippery, the antikickback pawls may not stop a kickback. Therefore, be especially attentive to following proper set-up and cutting procedures for ripping. Do not stand, or permit anyone else to stand, in line with a potential kickback.
- Q. If you stall or jam the sawblade in the workpiece, turn saw "OFF", remove the workpiece from the sawblade, and check to see if the sawblade is parallel to the miter gauge grooves and if the spreader is in proper alignment with the sawblade. If ripping at the time, check to see if the rip fence is parallel with the sawblade. Readjust as indicated.

- R. DO NOT remove small pieces of cut-off material that may become trapped inside the blade guard while the saw is running. This could endanger your hands or cause a kickback. Turn saw "OFF" and wait until blade stops.
- S. Use extra care when ripping wood that has a twisted grain or is twisted or bowed – it may rock on the table and/or pinch the sawblade.

10. KNOW YOUR CUTTING TOOLS

- A. Dull, gummy, or improperly sharpened or set cutting tools can cause material to stick, jam, stall the saw, or kickback at the operator. Minimize potential injury by proper cutting tool and machine maintenance. NEVER ATTEMPT TO FREE A STALLED SAWBLADE WITHOUT FIRST TURNING THE SAW OFF.
- B. Never use grinding wheels, abrasive cut-off wheels, friction wheels (metal slitting blades) wire wheels or buffing wheels.

11. USE ONLY ACCESSORIES DESIGNED FOR THIS SAW.

- 12. Crosscutting operations are more conveniently worked and with greater safety if an auxiliary wood facing is attached to the miter gauge using the holes provided. However, the facing must not interfere with the proper functioning of the sawblade guard.
- 13. Make sure the top of the arbor or cutting tool rotates toward you when standing in normal operating position. Also make sure the cutting tool, arbor collars and arbor nut are installed properly. Keep the cutting tool as low as possible for the operation being performed. Keep all guards in place whenever possible.
- 14. Do not use any blade or other cutting tool marked for an operating speed less than 3450 RPM. Never use a cutting tool larger in diameter than the diameter for which the saw was designed. For greatest safety and efficiency when ripping, use the maximum diameter blade for which the saw is designed, since under these conditions the spreader is nearest the blade.
- 15. Adjust table inserts flush with the table top. NEVER operate the saw unless the proper insert is installed.
- 16. NEVER feed material into the cutting tool from the rear of the saw. An accident and serious injury could result.
- 17. NEVER use another person as a substitute for a table extension, or as additional support for a workpiece that is longer or wider than the basic saw table, or to assist in feeding or supporting or pulling the workpiece.

MOTOR SPECIFICATIONS AND ELECTRICAL REQUIREMENTS

This saw is designed to use a 3450 RPM motor only. Do not use any motor that runs faster than 3450 RPM. It is wired for operation on 110-120 volts, 60 Hz., alternating current. IT MUST NOT BE CONVERTED TO OPERATE ON 230 VOLTS. EVEN THOUGH SOME OF THE RECOMMENDED MOTORS ARE DUAL VOLTAGE. Changing to 230 volt will not conserve energy and requires changing the power cord plug.

The outlet in the switch box will accept only a 15 amp. motor plug.

RECOMMENDED CRAFTSMAN MOTORS FOR USE ON THIS SAW.

| H.P. | R.P.M. | Volts | Catalog No. |
|------|--------|---------|-------------|
| 1 | 3450 | 110-120 | 1217 |
| 1 | 3450 | 110-120 | 1220 |

CAUTION: Do not use blower or washing machine motors or any motor with an automatic reset overload protector as their use may be hazardous.

DO NOT pull the workpiece through the sawblade - position your body at the nose (in-feed) side of the guard; start and complete the cut from the same side. This will require added table support for long or wide workpieces that extend beyond the length or width of the saw table.

18. THINK SAFETY.

Safety is a combination of operator common sense and alertness at all times when the saw is being used.

19. NOTE AND FOLLOW SAFETY INSTRUCTIONS THAT APPEAR ON THE FRONT OF YOUR SAW.

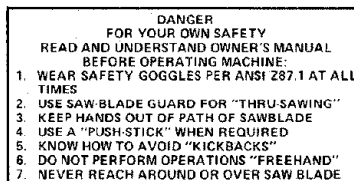

20. WARNING: DO NOT ALLOW FAMILIARITY (GAINED FROM FREQUENT USE OF YOUR SAW) TO BECOME COMMONPLACE. ALWAYS REMEMBER THAT A CARELESS FRACTION OF A SECOND IS SUFFICIENT TO INFLICT SEVERE INJURY.

21. WARNING: THE 2-1/2" SAW PULLEY AND THE 2-1/2" MOTOR PULLEY FURNISHED, WILL RUN THE BLADE AT APPROXIMATELY 3450 RPM WHEN USED WITH A 3450 RPM MOTOR. NEVER SUBSTITUTE THESE PULLEYS TO INCREASE THIS SPEED BECAUSE IT COULD BE DANGEROUS.

NOTE: Do not overtighten arbor nut. Use the arbor wrench to just "snug" it.



The operation of any power tool can result in foreign objects being thrown into the eyes, which can result in severe eye damage. Always wear safety goggles complying with ANSI Z87.1 (shown on Package) before commencing power tool operation. Safety Goggles are available at Sears retail or catalog stores.

CONNECTING TO POWER SOURCE OUTLET

This saw must be grounded while in use to protect the operator from electrical shock.

If power cord is worn or cut, or damaged in any way, have it replaced immediately.

If your saw is for use on less than 150 volts it has a plug that looks like below.

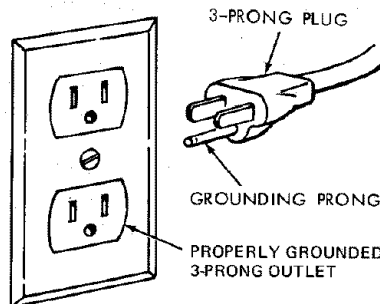

Plug power cord into 110-120V properly grounded type outlet protected by a 15-amp. time delay or Circuit-Saver fuse or circuit breaker.

IF YOU ARE NOT SURE THAT YOUR OUTLET IS PROPERLY GROUNDED, HAVE IT CHECKED BY A QUALIFIED ELECTRICIAN.

WARNING: DO NOT PERMIT FINGERS TO TOUCH THE TERMINALS OF PLUG WHEN INSTALLING OR REMOVING THE PLUG TO OR FROM THE OUTLET.

WARNING: IF NOT PROPERLY GROUNDED THIS POWER TOOL CAN INCUR THE POTENTIAL HAZARD OF ELECTRICAL SHOCK, PARTICULARLY WHEN USED IN DAMP LOCATIONS, IN PROXIMITY TO PLUMBING, OR OUT OF DOORS. IF AN ELECTRICAL SHOCK OCCURS THERE IS THE POTENTIAL OF A SECONDARY HAZARD SUCH AS YOUR HANDS CONTACTING THE SAWBLADE.

This saw is equipped with a 3-conductor cord and grounding type plug which has a grounding prong, approved by Underwriters' Laboratories and the Canadian Standards Association. The ground conductor has a green lug and is attached to the tool housing at one end and to the ground prong in the attachment plug at the other end.

This plug requires a mating 3-conductor grounded type outlet as shown.

If the outlet you are planning to use for this saw is of the two prong type **DO NOT REMOVE OR ALTER THE GROUNDING PRONG IN ANY MANNER.** Use an adapter as shown and always connect the grounding lug to a known ground.

It is recommended that you have a qualified electrician replace the TWO prong outlet with a properly grounded THREE prong outlet.

An adapter as shown below is available for connecting plugs to 2-prong receptacles. The green grounding lug extending from the adapter must be connected to a permanent ground such as to a properly grounded outlet box.

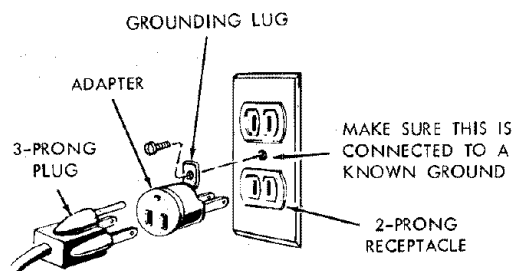

NOTE: The adapter illustrated is for use only if you already have a properly grounded 2-prong receptacle.

The use of any extension cord will cause some loss of power. To keep this to a minimum and to prevent over-heating and motor burn-out, use the table below to determine the minimum wire size (A.W.G.) extension cord. Use only 3 wire extension cords which have 3 prong grounding type plugs and 3-pole receptacles which will accept the plug on the saw.

| 1 H.P. MOTOR 110-120V | |
|-----------------------|------------------|
| Extension Cord Length | Wire Size A.W.G. |
| Up to 50 Ft. | 14 |
| 50 to 100 Ft. | 12 |
| 100 - 200 Ft. | 10 |
| 200 - 400 Ft. | 8 |

CHECK MOTOR ROTATION

WARNING: FOR YOUR OWN SAFETY, MAKE SURE PLUG IS NOT CONNECTED TO POWER SOURCE OUTLET WHEN CHANGING MOTOR ROTATION.

The motor must rotate **CLOCKWISE** when viewed from the shaft end to which you will mount the pulley. (See page 16.) If it does not, change the direction according to the instructions furnished with the motor.

CONTENTS

| | |
|--|----|
| WARRANTY | 2 |
| GENERAL SAFETY INSTRUCTIONS FOR POWER TOOLS | 2 |
| ADDITIONAL SAFETY INSTRUCTIONS FOR TABLE SAWS | 3 |
| MOTOR SPECIFICATIONS AND ELECTRICAL REQUIREMENTS | 4 |
| UNPACKING AND CHECKING CONTENTS | 6 |
| Tools Needed | 6 |
| List of Loose Parts | 6 |
| ASSEMBLY | 8 |
| Installing Handwheels | 8 |
| Checking Table Insert | 8 |
| Checking Blade Squareness to Table | 8 |
| Assembling Steel Legs | 9 |
| Mounting Saw | 9 |
| Attaching Table Extensions | 10 |
| Installing Rip Fence Guide Bars | 10 |
| Aligning Rip Fence | 12 |
| Adjusting Rip Scale Indicator | 14 |
| Installing Blade Guard | 14 |
| Mounting the Motor | 16 |
| Installing Belt Guard | 18 |
| Assembling Hold-Down | 19 |
| Plugging in Motor | 19 |
| GETTING TO KNOW YOUR SAW | 20 |
| On-Off Switch | 20 |
| Elevation Handwheel | 21 |
| Tilt Handwheel | 21 |
| Tilt Lock Handle | 21 |
| Rip Fence | 21 |
| Miter Gauge | 21 |
| Blade Guard | 21 |

| | |
|---|----|
| Table Insert | 21 |
| Removing and Installing Sawblade | 22 |
| Exacti-Cut | 22 |
| BASIC SAW OPERATION USING THE MITER GAUGE | 23 |
| Work Helpers | 23 |
| Crosscutting | 24 |
| Repetitive Cutting | 24 |
| Miter Cutting | 25 |
| Bevel Crosscutting | 25 |
| Compound Miter Cutting | 25 |
| Using the Hold-Down | 26 |
| BASIC SAW OPERATION USING THE RIP FENCE | 27 |
| Ripping | 27 |
| Bevel Ripping | 27 |
| Ploughing and Molding | 29 |
| Resawing | 29 |
| Cutting Panels | 29 |
| Rabbeting | 29 |
| Dadoing | 30 |
| Using Featherboards | 30 |
| ADJUSTMENTS | 31 |
| Miter Gauge | 31 |
| Heeling Adjustment or Parallelism of Sawblade to Miter Gauge Groove | 31 |
| Blade Tilt, or Squareness of Blade to Table | 32 |
| Tilt Mechanism | 34 |
| MAINTENANCE | 35 |
| LUBRICATION | 35 |
| RECOMMENDED ACCESSORIES | 35 |
| TROUBLE SHOOTING | 36 |
| REPAIR PARTS | 38 |

UNPACKING AND CHECKING CONTENTS

TOOLS NEEDED

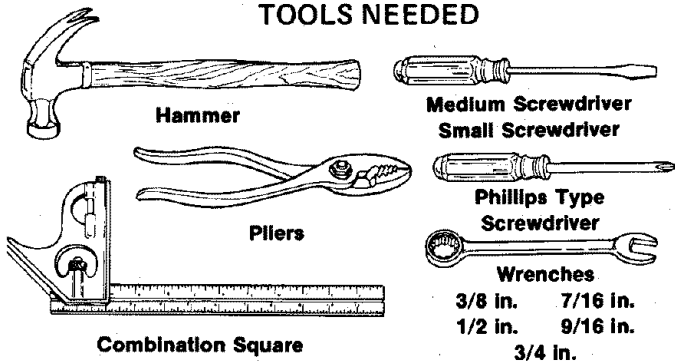

COMBINATION SQUARE MUST BE TRUE.

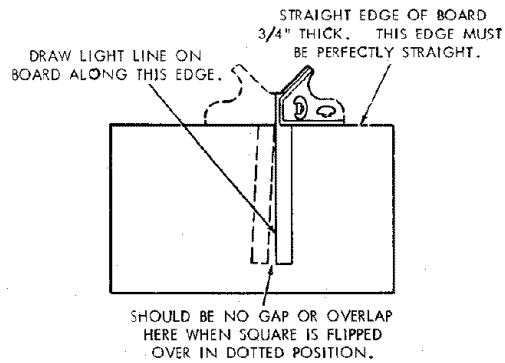

LIST OF LOOSE PARTS

| Item | Part Name | Qty. |
|--|--|------|
| A | Blade Guard and Spreader | 1 |
| B | Rip Fence | 1 |
| C | Owners Manual | 1 |
| D | Miter Gauge | 1 |
| E | Arbor Nut Wrench* | 1 |
| F | Switch w/ Key | 1 |
| G | Rip Fence Guide Bar with Rip Scale (Front) | 1 |
| H | Handwheel | 2 |
| J | V-Belt 1/2 in. x 41 in.* | 1 |
| K | Pulley, 2-1/2 in. dia., with 5/8 in. bore* | 1 |
| L | Belt and Pulley Guard | 1 |
| M | Belt Guard Clip | 3 |
| N | Self-Threading Screw, 10-32 x 1/2 in. long | 2 |
| O | Belt Guard Support | 1 |
| P | Belt Guard Support Bracket | 1 |
| Q | Motor Base | 1 |
| R | Spreader Rod* | 1 |
| S | Blade Guard Support with Screw* | 1 |
| T | Spreader Support* | 1 |
| U | Rip Fence Guide Bar (Rear) | 1 |
| V | Rip Fence Guide Bar Rod | 1 |
| *Pkg. of Miscellaneous Small Parts No. 62751 | | |
| Consisting of the Following: | | |
| W | Setscrew Wrench, 3/32 in. | 1 |
| W | Setscrew Wrench, 1/8 in. | 1 |
| W | Setscrew Wrench, 5/32 in. | 1 |
| X | Self-Threading Nut | 2 |
| Y | Hex Head Screw, 5/16-18 x 1-3/4 in. long | 2 |
| Y | Hex Head Screw, 5/16-18 x 5/8 in. long | 3 |
| Y | Hex Head Screw, 5/16-18 x 1 in. long | 4 |
| Y | Hex Head Screw, 1/4-20 x 5/8 in. long | 2 |
| Y | Hex Head Screw, 5/16-18 x 3/4 in. long | 2 |

*These parts are packaged in Loose Parts Bag No. 62750

Model 113.298142 Table Saw is shipped complete in one carton but DOES NOT INCLUDE Table Extension, Steel Legs, or motor.

Model 113.298032 Table Saw is shipped complete in one carton but INCLUDES Two Table Extensions, Steel Legs, and Motor.

Model 113.298240 Table Saw is shipped complete in one carton but INCLUDES Two Table Extensions, Steel Legs, Motor, and Hold Down.

Separate all parts from packing materials and check each one with the illustration and the list of Loose Parts to make certain all items are accounted for, before discarding any packing material.

If any parts are missing, do not attempt to assemble the table saw, plug in the power cord or turn the switch on until the missing parts are obtained and are installed correctly.

Remove the protective oil that is applied to the table top and edges of the table. Use any ordinary household type grease and spot remover.

CAUTION: Never use gasoline, naphtha or similar highly volatile solvents.

Apply a coat of automobile wax to the table.

Wipe all parts thoroughly with a clean, dry cloth.

WARNING: FOR YOUR OWN SAFETY, NEVER CONNECT PLUG TO POWER SOURCE OUTLET UNTIL ALL ASSEMBLY STEPS ARE COMPLETE, AND YOU HAVE READ AND UNDERSTAND THE SAFETY AND OPERATIONAL INSTRUCTIONS.

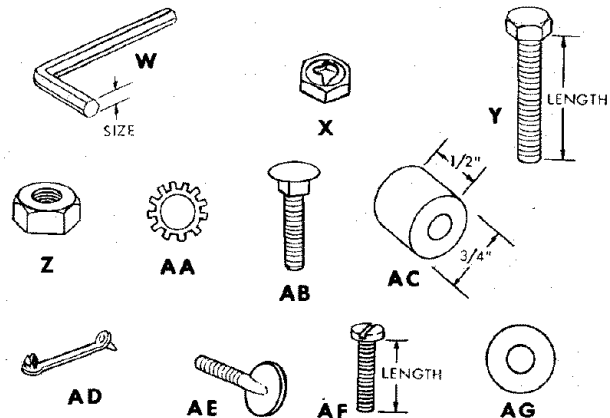
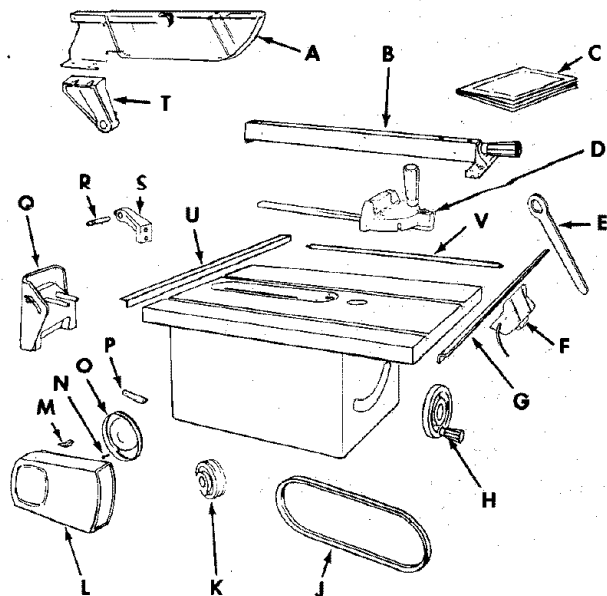

| Item | Part Name | Qty. |
|------|---|------|
| Z | Hex Nut, 5/16-18 (approx. dia. of hole 5/16 in.) | 9 |
| Z | Hex Nut, 1/4-20 (approx. dia. of hole 1/4 in.) | 2 |
| AA | Lockwasher, 5/16 in. External Type (approx. dia. of hole 5/16 in.) | 11 |
| AA | Lockwasher, 1/4 in. External Type (approx. dia. of hole 1/4 in.) | 2 |
| AA | Lockwasher No. 10 External Type (approx. dia. of hole 3/16 in.) | 1 |
| AB | Carriage Bolt, 5/16-18 x 3/4 in. long | 4 |
| AC | Rip Fence Guide Bar Spacer | 2 |
| AD | Wire Tie | 2 |
| AE | Thumbscrew, 5/16-18 x 1 in. long | 1 |
| AF | Screw Pan Hd. 10-32 x 3/4 | 1 |
| AG | Flat Washer (dia. of hole 21/64) | 2 |

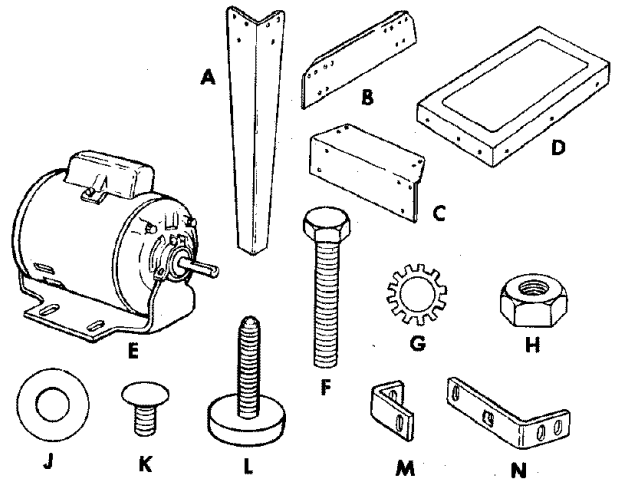

The following parts are included with Model 113.298032 and 113.298240.

| | | |
|---|-----------------|---|
| A | Leg | 4 |
| B | Side Stiffener | 2 |
| C | End Stiffener | 2 |
| D | Table Extension | 2 |
| E | Motor | 1 |

Pkg. of Miscellaneous Small Parts No. 62752 for Legs

| | | |
|---|---|----|
| F | Hex Head Screw 5/16-18 x 1-1/4 in. long | 4 |
| G | Lockwasher, 1/4 in. External Type (approx. dia. of hole 1/4 in.) | 24 |
| G | Lockwasher, 5/16 in. External Type (approx. dia. of hole 5/16 in.) | 4 |
| H | Hex Nut, 1/4-20 (approx. dia. of hole 1/4 in.) | 24 |
| H | Hex Nut, 5/16-18 (approx. dia. of hole 5/16 in.) | 4 |
| H | Hex Nut, 1/2-13 (approx. dia. of hole 1/2 in.) | 8 |
| J | Flat Washer (dia. of hole, 11/32 in.) | 8 |

Item Part Name Qty.

| | | |
|---|--|----|
| K | Truss Head Screw, 1/4-20 x 5/8 in. long (top of screw is rounded) | 24 |
| L | Leveling Foot | 4 |

Pkg. of Miscellaneous Small Parts No. 62745 for Table Extensions.

2 ea. for Model 113.298032 & 113.298240

Consisting of the following:

| | | |
|---|--|---|
| F | Hex Hd. Screw, 5/16-18 x 1-1/4 in. long | 4 |
| G | Lockwasher, External Type (approx. dia. of hole 1/4 in.) | 8 |
| G | Lockwasher, External Type (approx. dia. of hole 5/16 in.) | 4 |
| H | Hex Nut, 1/4-20 (approx. dia. of hole 1/4 in.) | 8 |
| H | Hex Nut, 5/16-18 (approx. dia. of hole 5/16 in.) | 4 |
| J | Flat Washer (dia. of hole 17/64 in.) | 2 |
| J | Flat Washer (dia. of hole 11/32 in.) | 4 |
| K | Truss Head Screw, 1/4-20 x 1 in. long (top of screw is rounded) | 8 |
| M | Corner Stiffener Bracket | 2 |
| N | Corner Support Bracket | 2 |

The Hold Down is included with Model 113.298240 only.

| Item | Part Name | Qty. |
|------|----------------|------|
| A | Clamp Assembly | 1 |
| B | Wing Screw | 2 |
| C | Washer | 2 |
| D | Support Rod | 1 |

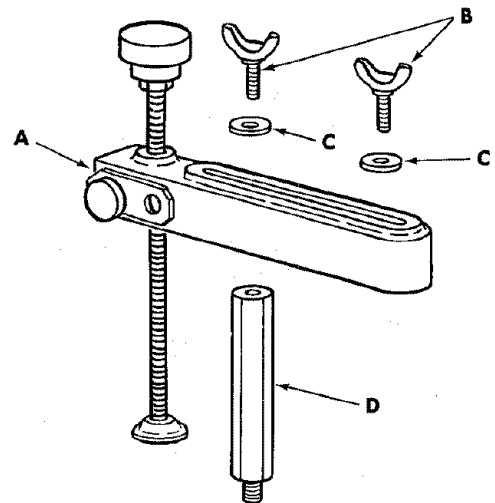

ASSEMBLY

Before mounting the saw on legs, a stand or a bench, the Table Insert and Blade Squareness must be checked at this time.

INSTALLING HANDWHEELS

1. Line up FLAT SPOTS on shaft and handwheel, push handwheel onto shaft. Install screw and lockwasher to lock handwheel on shaft.

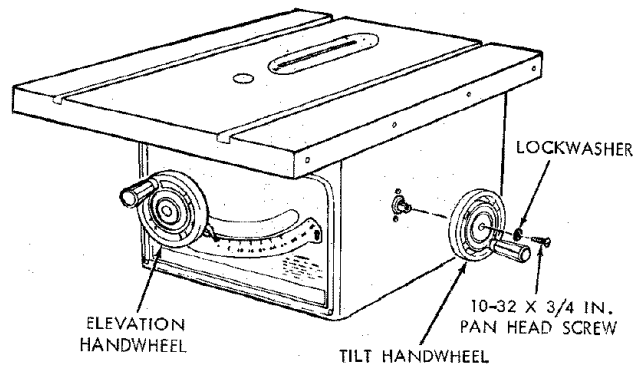

CHECKING TABLE INSERT

2. Insert should be flush with table top. Check as shown. Loosen flat head screw that holds insert and adjust the four set screws as necessary. Tighten flat head screw. Do not tighten screw to the point where it deflects the insert.

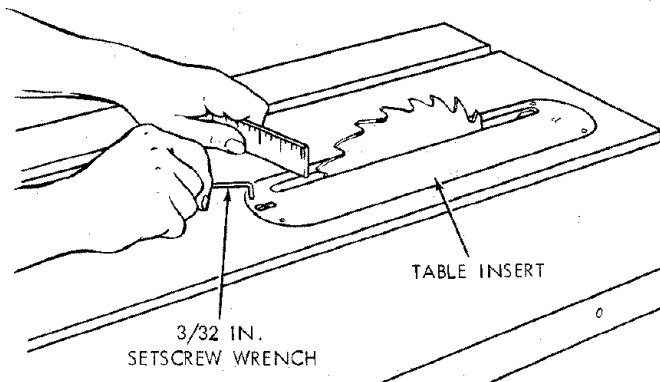

3. To remove insert.
 - A) Loosen Screw
 - B) Lift insert from front end, and pull toward front of saw.
4. To replace insert.

Place insert into insert opening in table and push toward rear of saw to engage spring clip and until keyslot in insert will drop over screw. Tighten screw.

Do not tighten screw to the point where it will deflect the insert.

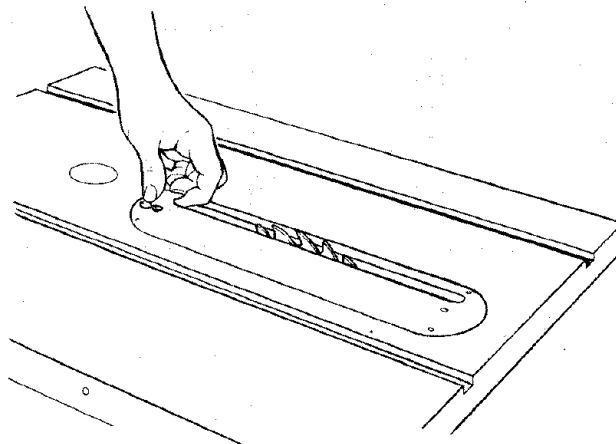

CHECKING BLADE SQUARENESS TO TABLE

IMPORTANT: BLADE must be SQUARE (90°) to TABLE, in order to proceed with assembly.

To check for blade squareness, refer to "BLADE TILT, OR SQUARENESS OF BLADE TO TABLE" adjustment on page 32.

CHECKING BLADE FOR HEEL

IMPORTANT: Saw blade MUST be parallel to miter gauge groove.

To check for parallelism, refer to "HEELING ADJUSTMENT OR PARALLELISM OF SAWBLADE TO MITER GAUGE GROOVE" adjustment on page 31 and 32.

ASSEMBLING STEEL LEGS

NOTE: Steel Legs are furnished with Model 113.298032 and 113.298240. From among the loose parts, find the following Hardware:

- 24 Truss Head Screws, 1/4 - 20 x 5/8 in. long (top of screw is rounded)
- 24 Lockwashers, 1/4 in. External Type (approx. dia. of hole 1/4 in.)
- 24 Hex Nuts, 1/4 - 20 (approx. dia. of hole 1/4 in.)
- 8 Hex Nuts, 1/2 - 13 (approx. dia. of hole 1/2 in.)
- 4 Leveling feet.

Assemble the legs as shown . . .

1. Insert the Truss Head Screws through the holes in the legs, then through the holes in the stiffeners. **MAKE SURE THE SCREWS GO THROUGH THE HOLES IN THE SIDE STIFFENERS MARKED "X"**.
2. Install the lockwashers . . . screw on the nuts but do not tighten until completely assembled.
3. Install leveling feet.

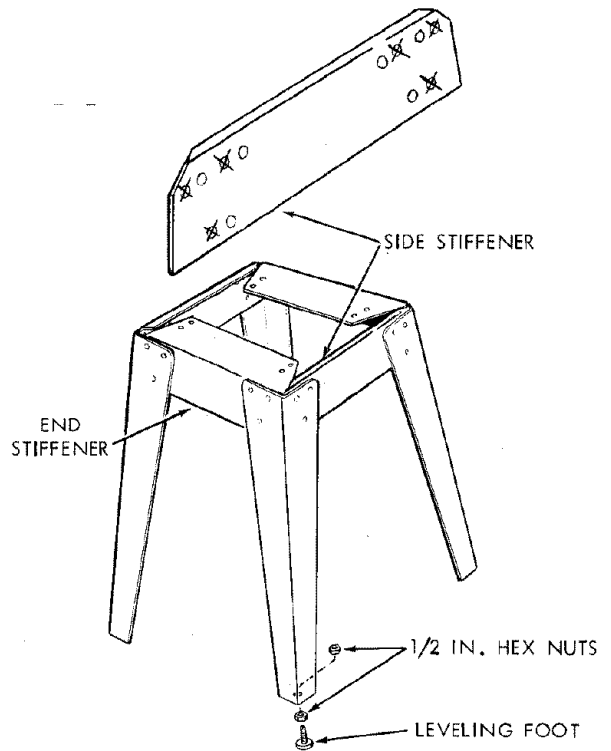

MOUNTING SAW

1. From among the loose parts, find the following hardware:
 - 4 Hex Head Screws, 5/16 - 18 x 1-1/4 in. long.
 - 4 Hex Nuts, 5/16 - 18 (approx. dia. of hole 5/16 in.)
 - 4 Lockwashers, 5/16 in. External Type (approx. dia. of hole, 5/16 in.)
 - 8 Flat Washers, (dia. of hole 11/32 in.)
2. Place saw on legs so that holes in bottom of saw line up with holes in top of legs.
3. Install screws, washers, lockwashers and nuts as shown.

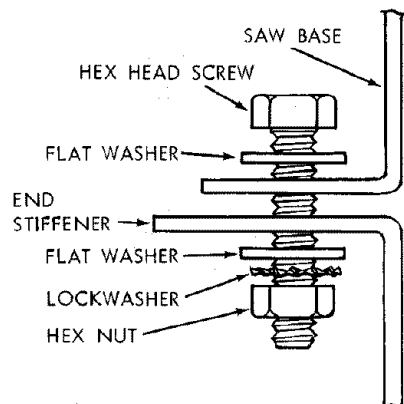

If you mount the saw on any other bench, make sure that there is an opening in the top of the bench the same size as the opening in the bottom of the saw so that the sawdust can drop through. Recommended working height is 33 to 37 inches from the top of the saw table to the floor.

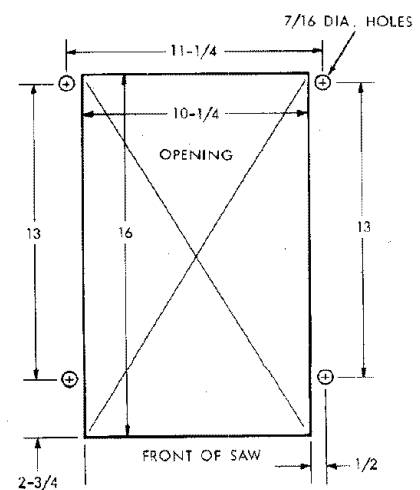
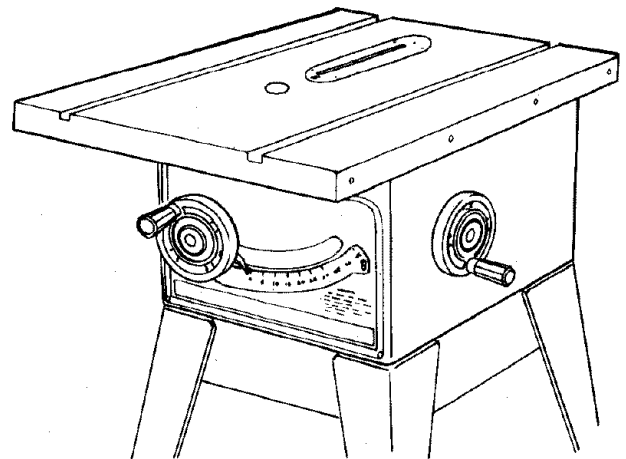

ATTACHING AND ASSEMBLING TABLE EXTENSIONS

If you received Table Extensions with your saw attach them at this time.

1. From among the loose parts find the following hardware.
 - 4 Corner Support Brackets
 - 4 Corner Stiffener Brackets
 - 16 Truss Hd. Screws 1/4-20 x 1
 - 16 Ext. Lockwashers 1/4
 - 16 Hex Nut 1/4-20
 - 8 Hex Hd. Screws 5/16-18 x 1-1/4
 - 8 Ext. Lockwasher 5/16
 - 8 Hex Nut 5/16-18
 - 4 Flat Washers (Dia. of hole 17/64)
 - 8 Flat Washers (Dia. of hole 11/32)

Assemble brackets with hardware as listed.

Insert 5/16-18 x 1-1/4 in. long screws through holes in EXTENSION then through table. Install flat washer, lockwashers, and screw on the nuts . . . **DO NOT TIGHTEN.**

Align front edge of extension with front edge of saw table. Pull Extension UPWARDS above table surface . . . **SLIGHTLY TIGHTEN SCREWS** using 1/2 in. wrench.

Using small block of hardwood and hammer, tap extension DOWNWARDS at front, center & rear, until it is **EVEN** with table surface . . . **TIGHTEN SCREWS.**

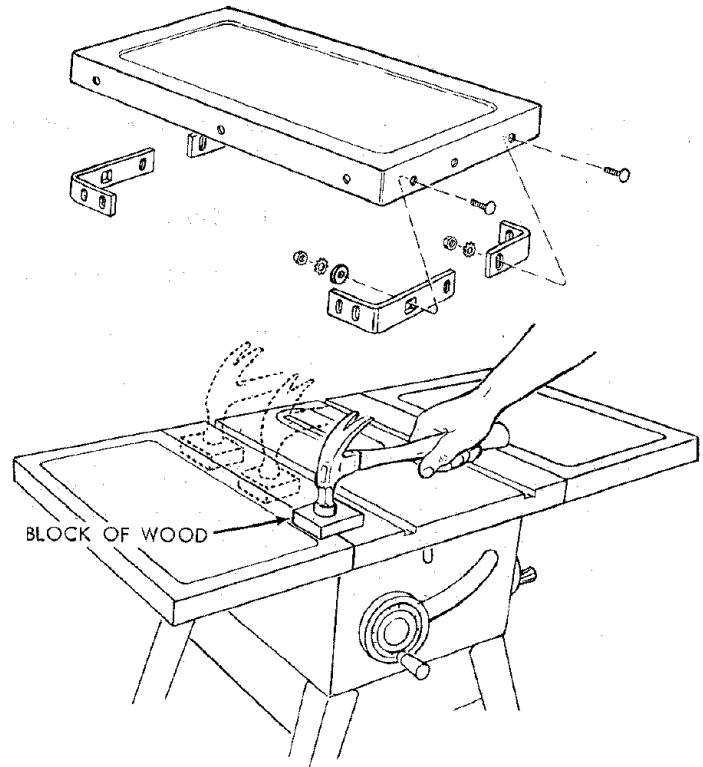

Lay REAR FENCE GUIDE BAR on table to act as a straightedge. If outer edge of extension is higher or lower than table surface;

- A. Slightly loosen nuts holding bracket to extension using 7/16 in. wrench.
- B. Move end of extension up or down until outer edge is even with table surface . . . check with GUIDE BAR . . . tighten nuts.
- C. Recheck INNER edge of extension to make sure it has not moved . . . readjust, if necessary.

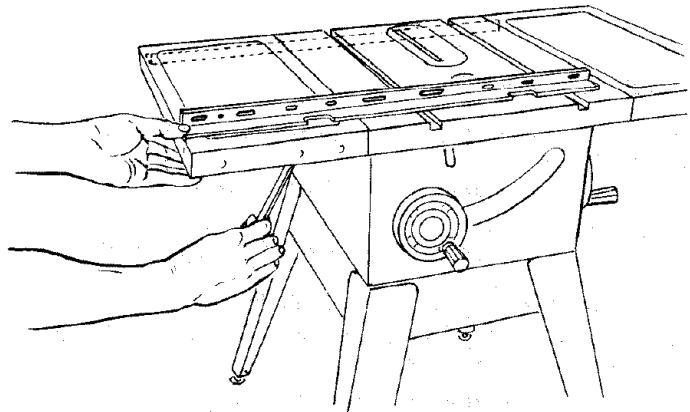

INSTALLING RIP FENCE GUIDE BARS AND SWITCH BOX

1. From among the loose parts find the following hardware:
 - 2 Hex. Head Screws, 5/16-18 x 1-3/4 in. long
 - 2 Hex. Head Screws, 5/16-18 x 1 in. long
 - 2 Hex. Head Screws 5/16-18 x 3/4 in. long
 - 6 External Lockwashers, 5/16 in. (approx. dia. of hole 5/16 in.)
 - 6 Hex. Nuts, 5/16-18 (approx. dia. of hole 5/16 in.)
 - 2 Flat washers (dia. of hole 21/64 in.)
 - 2 Spacers, 3/4 in. dia. x 1/2 in. long
 - 2 Self-threading nuts
 - 1 Fence Guide Bar Rod
2. Lay guide bars on saw table.
3. Insert a 1-3/4 inch long screw through the THIRD hole from LEFT IN THE FRONT BAR . . . Insert another

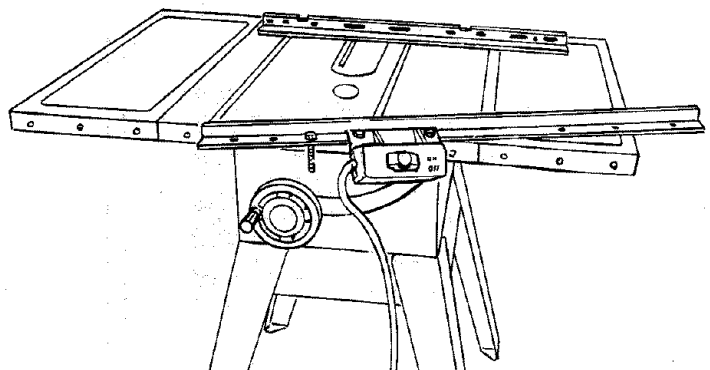

1-3/4 inch long screw through the SEVENTH hole in bar. Insert two 3/4 inch long screws through two flat washers, through holes in switch, and then through holes EIGHT and TEN in bar. Install two lockwashers and nuts then tighten.

4. Place spacers on screws.

5. Insert bolts through holes in middle and on right side of front of saw table ... install lockwashers and nuts. **DON'T SCREW NUTS ON ALL THE WAY**, just get them started on the screws.

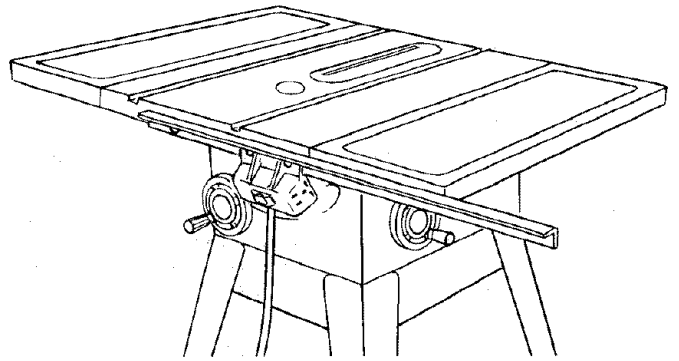

6. Remove the 3 screws from rear of table extension.
7. Insert 1 in. long screws in **SECOND** and **FOURTH** holes of rear bar and attach to table the same way.
8. Insert ends of **FENCE GUIDE BAR ROD** through round holes at outer end of bars.
NOTE: The ends of the **ROD** are not threaded ... the **SELF THREADING NUTS** will cut threads on the rod as they are screwed on.

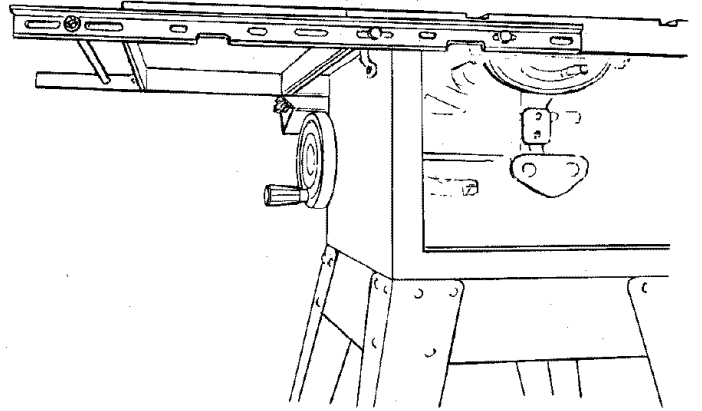

9. Hold rod with one hand and with a 1/2 in. wrench or pliers start screwing on **ONE** of the nuts only **A TURN OR TWO** ... screw on other nut the same way.
10. Using **TWO** 1/2 in. wrenches or pliers tighten both of the nuts.

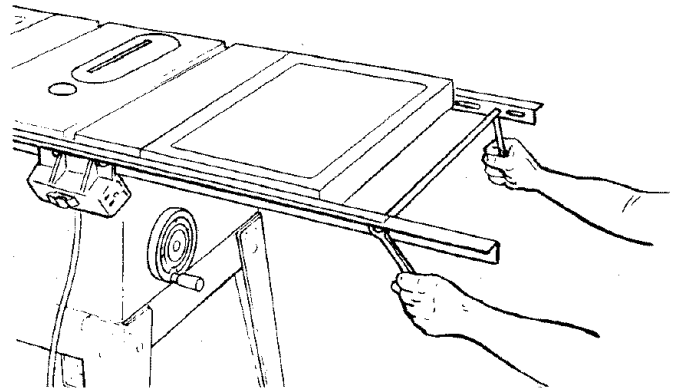

11. Slide the bars so that screws are in the **MIDDLE** of the slotted holes.
12. Position rip fence over miter gauge groove, holding up the rear end while engaging front end with bar ... lower fence onto table.

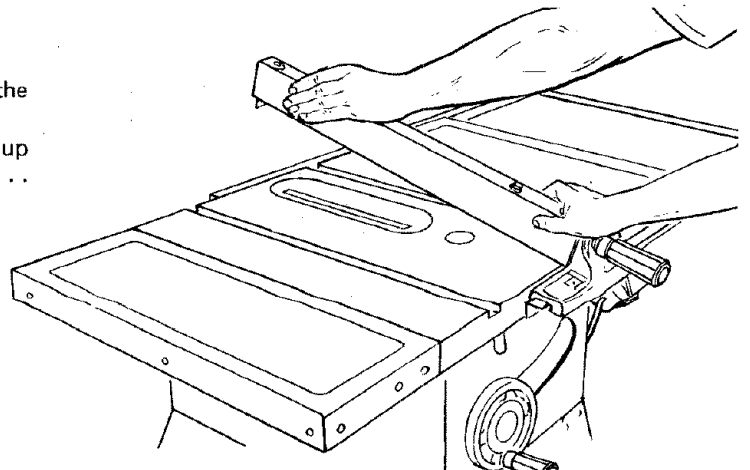

13. Raise blade all the way up.
14. Carefully move fence against blade.
15. Move front bar until "0" mark on rip scale is approximately inline with indicator.
16. Move FRONT bar upwards until fence is approximately 1/32 in. above table ... tighten screw at left end of bar.

NOTE: Fold a piece of newspaper making 8 thicknesses and place between rip fence and table to act as a spacer. This will hold the fence off of the table approx. 1/32 in.

17. Adjust rear bar so that the fence is approximately 1/32 in. above table make sure it is square with fence guide bar rod ... tighten screw at end of bar.
18. Replace screws in rear of table extension ... be sure top surface of extension is PARALLEL to top surface of rear guide bar.

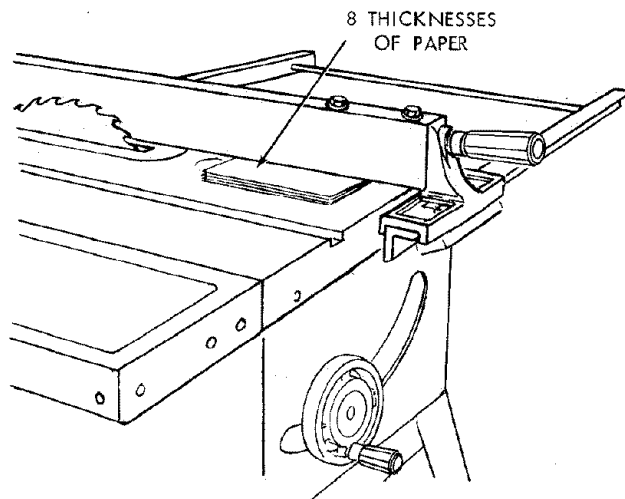

19. Move fence to RIGHT edge of table ... make sure it is approx. 1/32 in. above table at front and rear and tighten screws.

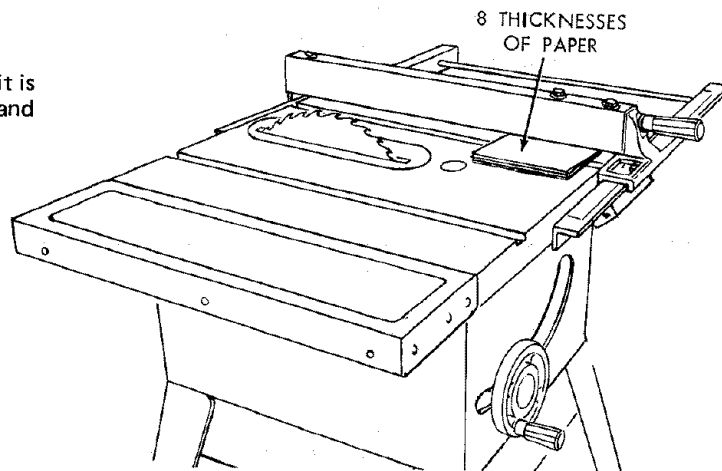

ALIGNING RIP FENCE

The fence should slide easily along the bars and always remain in alignment (parallel to sawblade and miter gauge grooves).

The alignment is maintained by a spring underneath the fence which bears against the front guide bar.

To move the fence, loosen the lock handle and grasp the fence with one hand at the front.

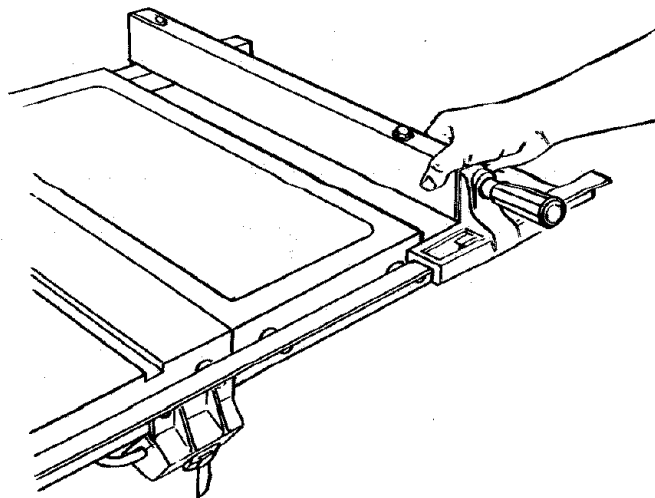

For very close adjustments, grasp the guide bar with both hands and move the fence with your thumbs.

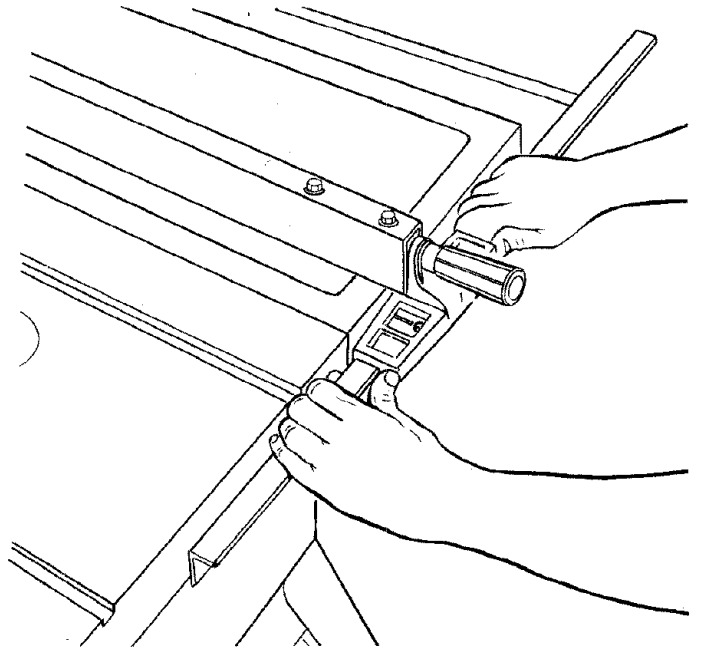

Place fence on saw but **DO NOT LOCK IT**.
Move the **REAR END** of the fence slightly to the right or left ... when you release it, the fence should "spring" back to its original position.
If it does not, the spring pressure must be **INCREASED**.

1. Loosen the screws.
2. Move Spring slightly toward front of fence.

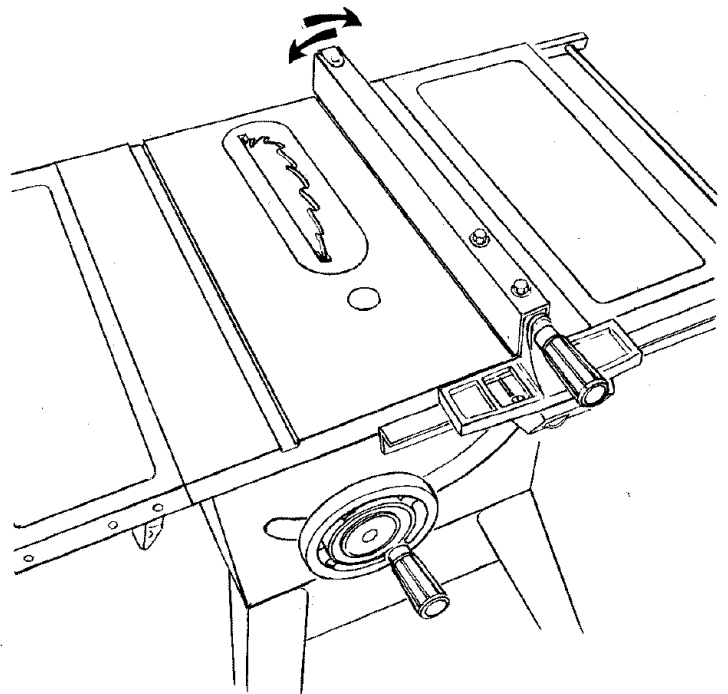

If the fence does not slide easily along the bars, the pressure of the spring can be **REDUCED**.

1. Loosen the screws.
2. Move spring slightly toward rear of fence ... tighten screws.

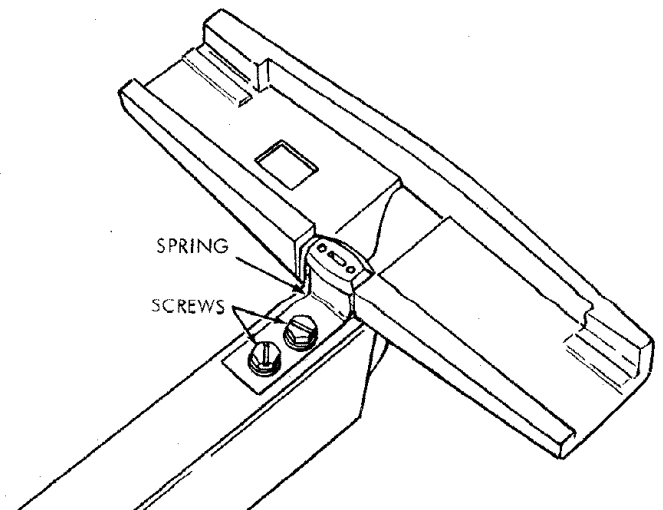

3. The rip fence must be PARALLEL with the sawblade (see page 31) and miter Gauge grooves . . . Move fence until it is along side of groove. Do NOT LOCK IT. It should be parallel to groove. If it is not;
 - A. Loosen the two "Hex. Head Screws."
 - B. Hold fence head tightly against bar . . . move end of fence so that it is parallel with groove.
 - C. Alternately tighten the screws.

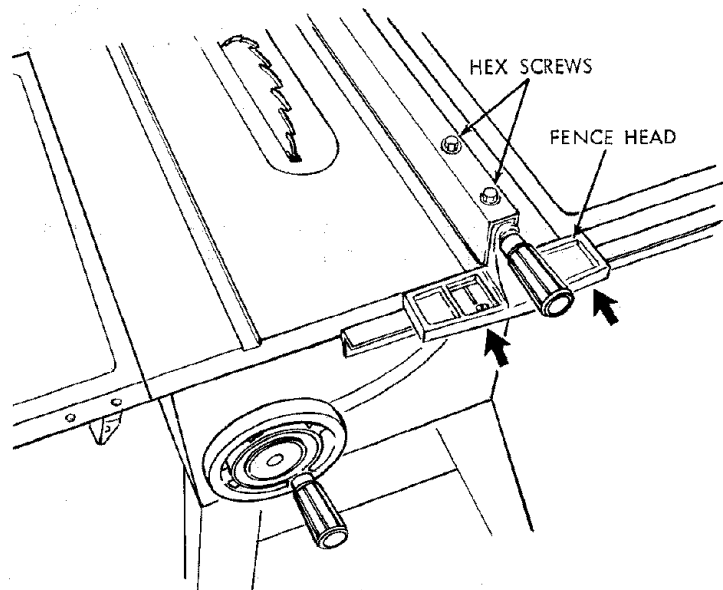

ADJUSTING RIP SCALE INDICATOR

1. Turn ELEVATION HANDWHEEL clockwise until blade is up as high as it will go.
IMPORTANT: BLADE must be SQUARE (90°) to TABLE, in order to ALIGN rip fence.
2. Using a rule, position fence on right side of sawblade 2 in. from the sides of the teeth . . . tighten lock handle.
3. Loosen screw holding the indicator . . . adjust so that it points to "2" on the rip scale . . . tighten screw.

NOTE: If you cannot adjust indicator so that it points to "2", loosen the screws holding the front guide bar and move the guide bar.

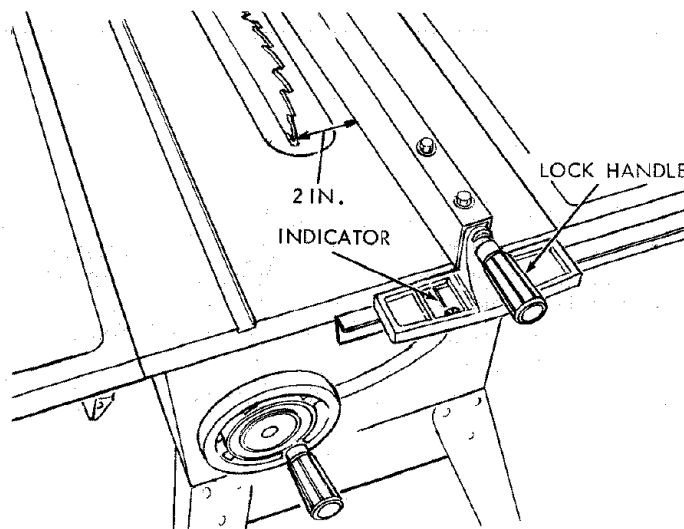

INSTALLING BLADE GUARD

1. From among the loose parts, find
 - 2 Hex Head Screws, 1/4 - 20 x 5/8 in. long
 - 2 Hex Head Screws, 5/16 - 18 x 5/8 in. long
 - 2 Hex Head Screws, 5/16 - 18 x 1 in. long
 - 2 Hex Nuts, 1/4 - 20 (approx. dia. of hole 1/4 in.)
 - 2 Lockwashers, 1/4 in. External Type (approx. dia. of hole 1/4 in.)
 - 2 Lockwashers, 5/16 in. External Type (approx. dia. of hole 5/16 in.)
 - 1 Thumbscrew
 - Guard Support
 - Spreader Support
 - Spreader Rod
2. Lower the blade.
3. Screw the two MOTOR BASE CLAMP SCREWS part way into cradle.
4. Attach GUARD SUPPORT . . . DO NOT TIGHTEN screws.

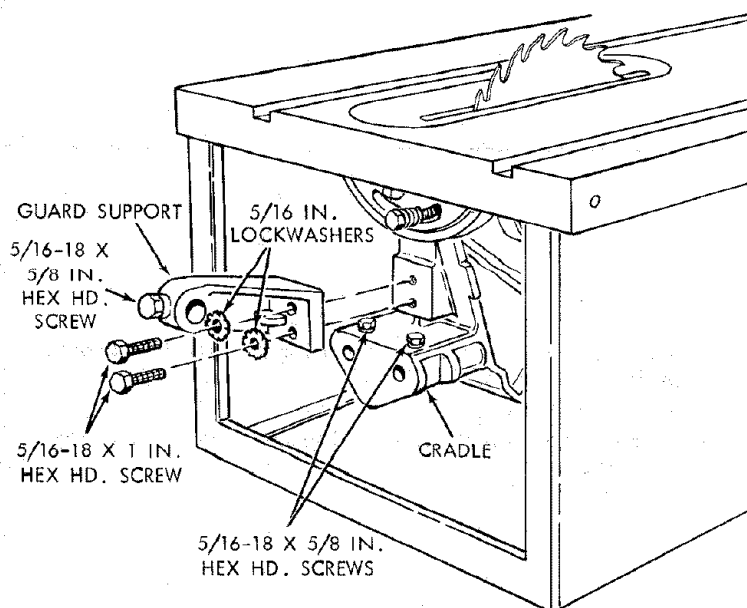

5. Insert SPREADER ROD into SPREADER SUPPORT until pin fits into notch. Insert Thumbscrew and tighten it.

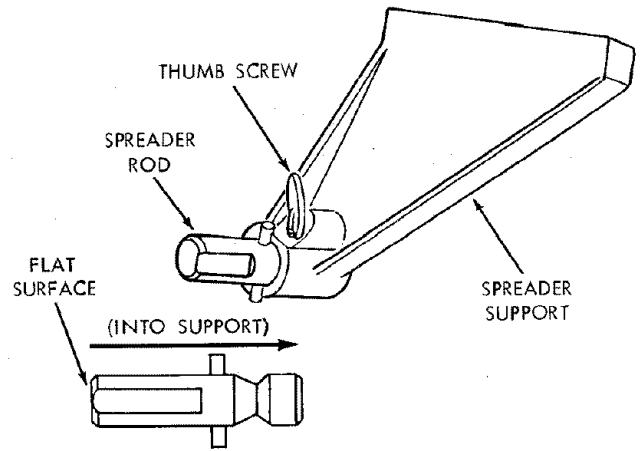

6. Slide SPREADER ROD into GUARD SUPPORT until left end of ROD extends approximately 1/4 inch beyond edge of SUPPORT ... Snug up Hex Head Screw in SUPPORT.
7. Attach SPREADER to SPREADER SUPPORT so that screws are all the way back in the SLOTS of SUPPORT ... tighten screws.
8. Raise ANTIKICKBACK PAWLS (hold in place with a setscrew wrench — see below) ... align spreader SQUARE to table (be sure insert is properly adjusted).
NOTE: The framing (or combination) square must be "true" — see start of "assembly and alignment" section on page 6 for checking method.
 ... Tighten both 5/16-18 x 1 in. HEX HEAD SCREWS.

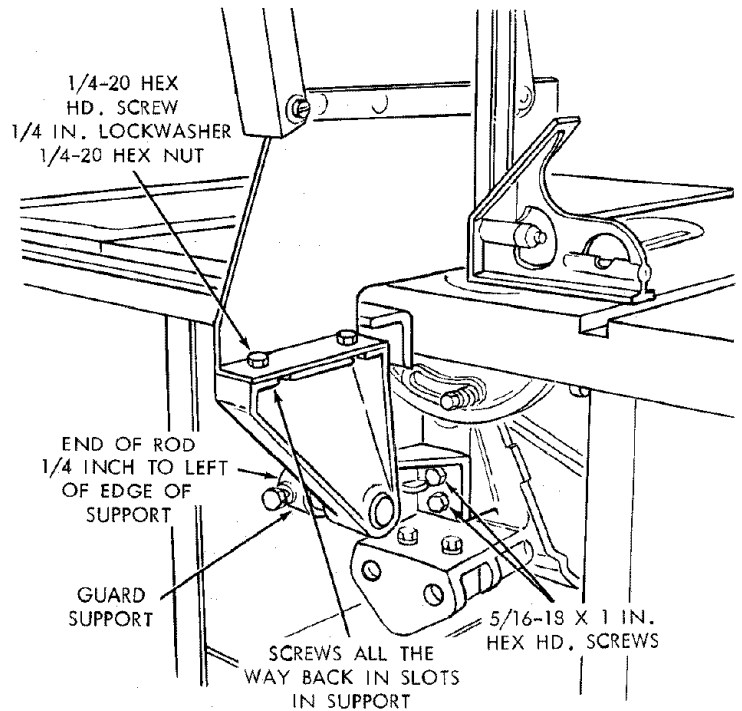

9. Raise blade all the way up ... make sure it is square with table.
10. Raise Blade Guard ... lift up both ANTIKICKBACK PAWLS ... insert one of the SETSCREW WRENCHES in the notches to hold the pawls out of the way.
11. Lay blade of square or other straightedge alongside of blade.
12. Loosen Hex Head Screw in GUARD SUPPORT and move spreader so that it touches blade of square ... tighten screw.
13. **NOTE:** The spreader is now square with the table and approximately in line with the sawblade. The spreader requires further adjustment to align it PARALLEL to the blade and in the MIDDLE of the cut (KERF) made by the sawblade.

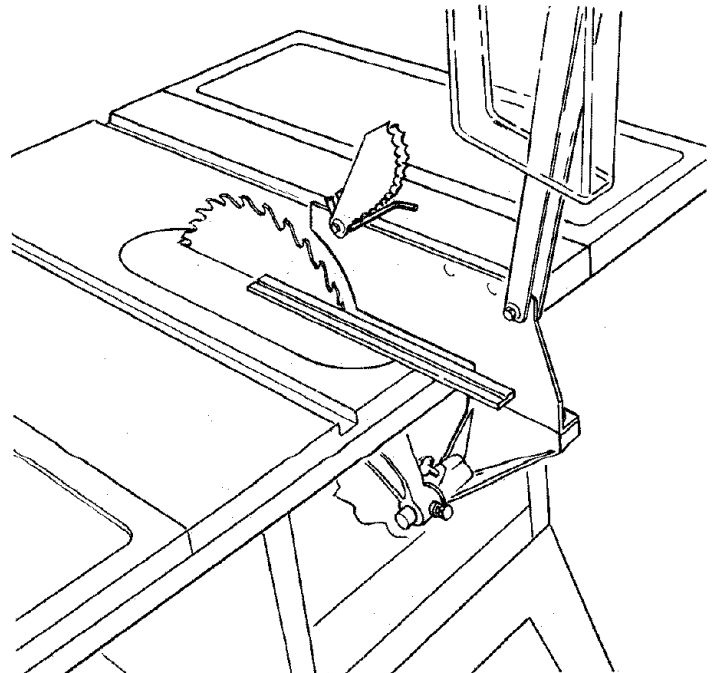

14. **IMPORTANT:** The SPREADER must always be PARALLEL to the sawblade and in the MIDDLE of the cut (KERF) made by the sawblade.

NOTE: The spreader is thinner than the width of the KERF by approximately six thicknesses of paper.

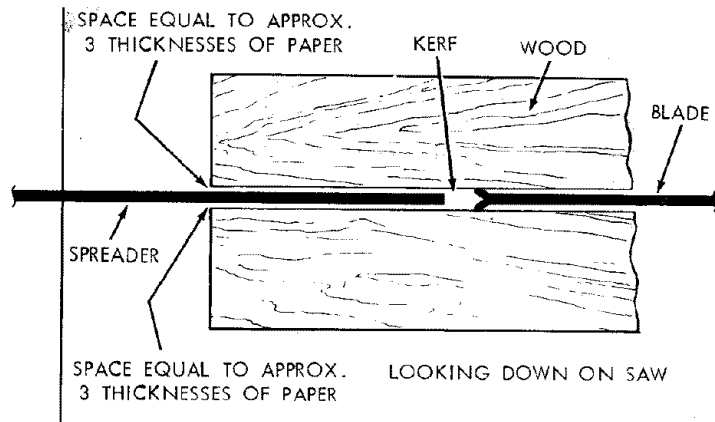

15. Make two folds in a small piece (6 x 6 in.) of ordinary NEWSPAPER making three thicknesses.

The folded paper will be used as a "spacing gauge".

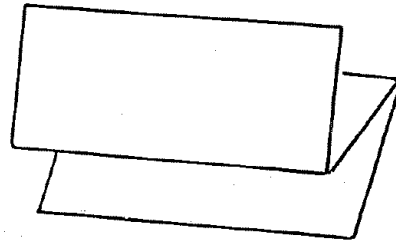

16. Place RIP FENCE on table ...

CAREFULLY move it against blade so that it is parallel to the blade, and just TOUCHES tips of saw teeth ... tighten RIP FENCE LOCK KNOB HANDLE.

17. Insert folded paper between SPREADER and FENCE ... hold spreader flat against fence ... tighten screws using 7/16 in. wrench. Now tighten Hex Hd. Screws in Support.

18. To remove BLADE GUARD AND SPREADER, loosen THUMBSCREW ... DO NOT LOOSEN OTHER SCREWS.

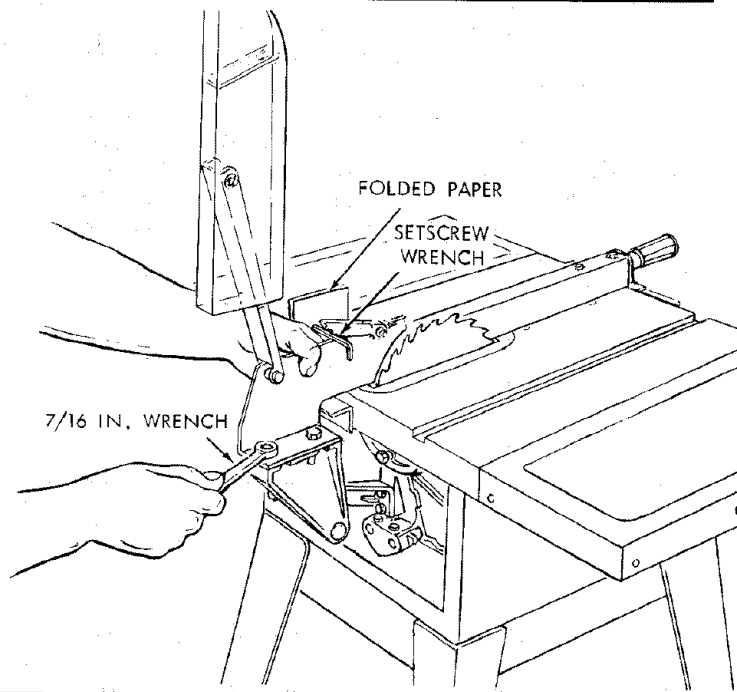

MOUNTING THE MOTOR

NOTE: Motor is included with Model 113.298032 and 113.298240.

CHECK MOTOR ROTATION

1. The motor must rotate **CLOCKWISE** when viewed from the 5/8 in. shaft.
2. **MAKE SURE "KEY" IS REMOVED FROM SHAFT.**
3. Place the motor on your workbench or on the floor.
4. Plug the cord into a properly grounded outlet (See "Motor Specifications and Electrical Requirements" Section) Notice the rotation of the shaft. If it is not turning **CLOCKWISE**, REMOVE the plug from the outlet, and change the rotation of the motor according to the instructions furnished with the motor.

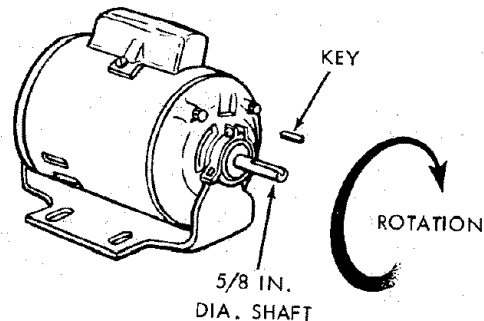

WARNING: FOR YOUR OWN SAFETY, MAKE SURE PLUG IS NOT CONNECTED TO POWER SOURCE OUTLET WHEN CHANGING MOTOR ROTATION.

5. From among the loose parts, find the following hardware:
 4 Carriage Bolts, 5/16 - 18 x 3/4 in. long
 4 Hex. Nuts, 5/16 - 18
 (approx. dia. of hole 5/16 in.)
 4 Lockwashers, 5/16 in. External Type
 (approx. dia. of hole 5/16 in.)
6. Place motor on MOTOR BASE ... insert bolts through holes in base ... then through the motor. Install lockwashers, and nuts.
7. Position motor so that edge of MOTOR FOOT and MOTOR BASE are even ... slide motor all the way to the RIGHT ... tighten the four nuts.
8. Loosen set screw in motor pulley using 5/32 in. setscrew wrench. Slide pulley on shaft with HUB away from motor. DO NOT TIGHTEN SETSCREW.
9. Install 3/16" in. square key (furnished with motor) in grooves in pulley and motor shaft. DO NOT TIGHTEN SETSCREW.

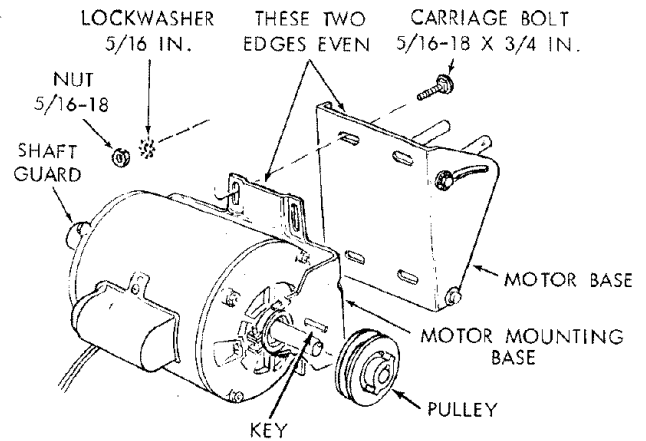

10. Lift motor and insert the TWO PINS on motor base into HOLES in cradle ... push motor in as far as it will go.
11. Lower the blade ... install belt on saw pulley and motor pulley.
12. Sight along edges of both pulleys and move motor pulley so that belt is parallel to the edges of both pulleys ... tighten the setscrew in the motor pulley.
13. **IMPORTANT:** Measure the distance from end of motor shaft to pulley ... mark this dimension down; you will need it later when reinstalling the pulley.
14. Make sure blade is 90° to table ... raise it all the way up.
15. Lift motor until edge of washer is even with end of slot ... tighten pivot screw. In this position, pull motor toward you (pins will slide out of cradle) until belt is TIGHT ... tighten the two MOTOR BASE CLAMP SCREWS.
16. Loosen Pivot Screw slightly.
17. Lower the saw blade all the way down.
18. **IMPORTANT:** Motor should pivot freely downward as blade is lowered. If it does not, LOOSEN the PIVOT SCREW some more.
19. Pivot screw must be adjusted only tight enough to allow motor to pivot FREELY as blade is raised or lowered. This will maintain constant tension on belt.

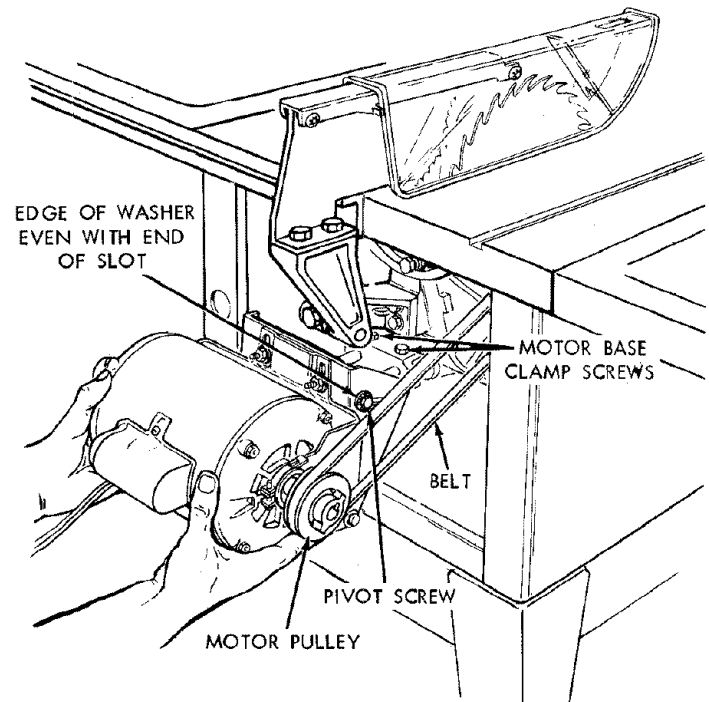

20. Loosen the two MOTOR CLAMP SCREWS on each end of motor. Rotate the motor so that the CAPACITOR COVER is on top ... tighten the screws. The ventilation holes are now facing downward which will help prevent sawdust from entering motor.

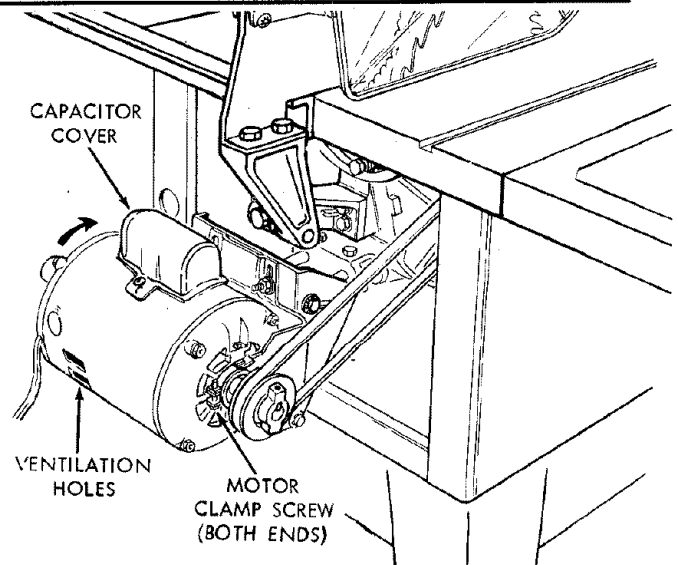

INSTALLING BELT GUARD

1. Remove the belt and motor pulley.
2. Screws furnished with guard are "self threading" ... screw them into holes in BELT GUARD SUPPORT BRACKET, then remove them.
3. Position BELT GUARD SUPPORT BRACKET and BELT GUARD SUPPORT as shown and install the screws ... make sure motor shaft is in CENTER of hole in SUPPORT.

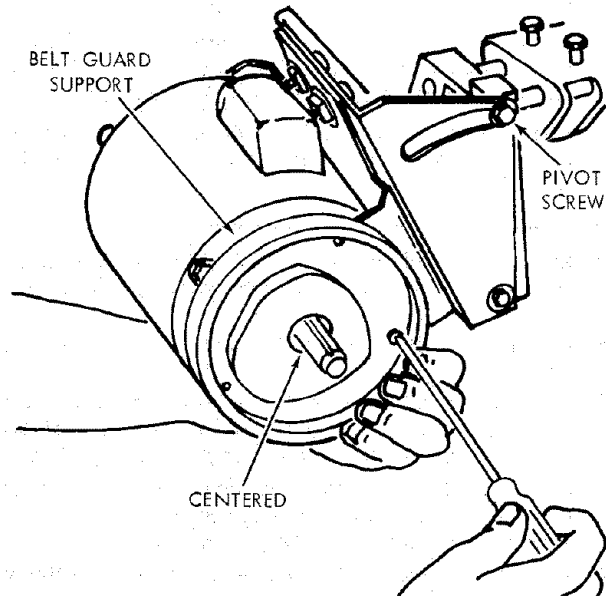
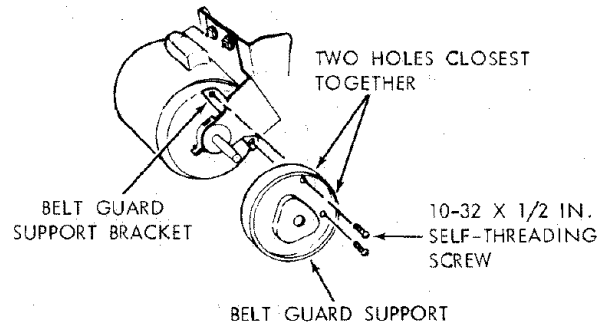

4. Install three CLIPS (furnished with guard) 90° apart starting with one clip at the end of the guard as shown ... LONG END of clip facing AWAY from you.

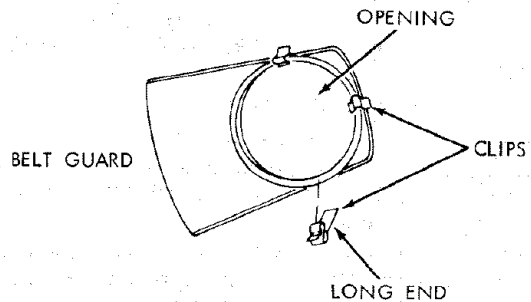

5. Reinstall motor pulley the same way it was when you aligned the belt.
6. Place belt on SAW PULLEY ... insert end of belt through opening in END of guard.
7. Slip belt over motor pulley.

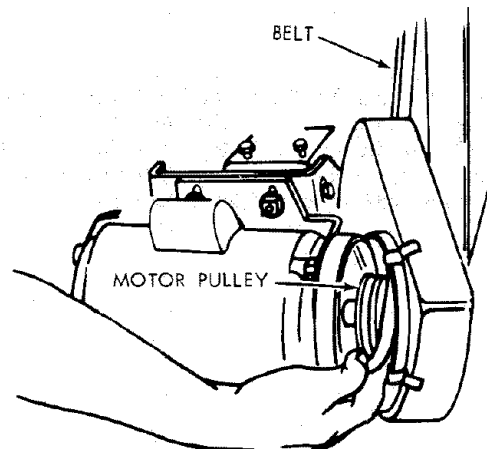

- Press guard onto support so that bottom of guard is approximately 3/4 in. away from belt.

NOTE: To remove guard, lift up on **LONG TABS** of clips . . . pull guard outward. The clips should remain on the **BELT GUARD SUPPORT**.

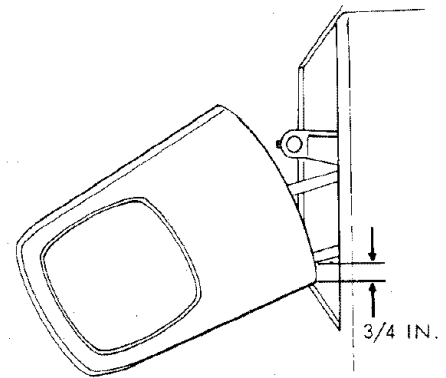

ASSEMBLING HOLD-DOWN (Included with Model 113.298240)

Locate the clamp assembly, support rod, two wing screws and two washers in loose parts bag.

Screw the support rod (1) tightly into the hole in the miter gauge head.

Position the clamp assembly (2) on the handle and rod . . . install washers (3) and wing screws (4).

NOTE: The small knob (5) on the clamp screw must not turn. Check nut underneath it . . . it must be tight against the knob. Use a 1/2 inch wrench to tighten it.

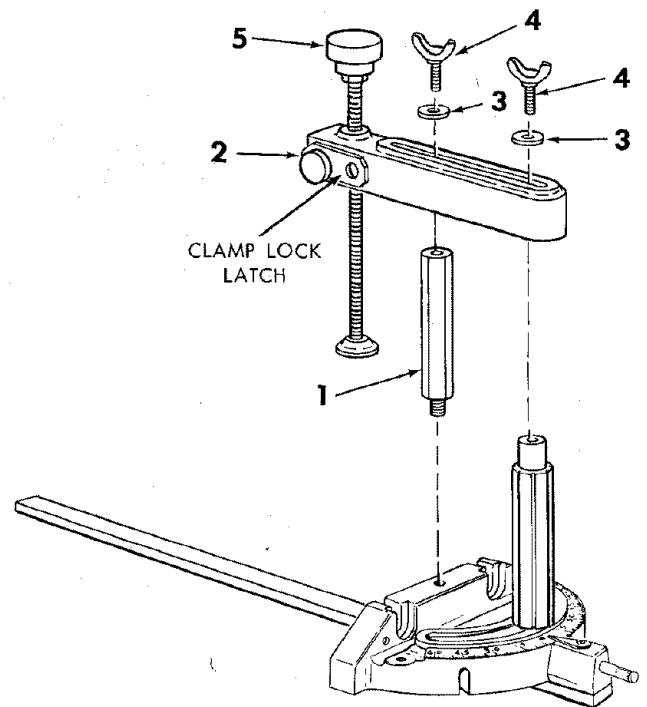

PLUGGING IN MOTOR

- From among the loose parts, find two wire ties
- Route motor cord along right side of cabinet and snap ties in 1/4" hole in side of cabinet. Secure two cords in wire ties.
- Plug motor cord into outlet on side of switch box.

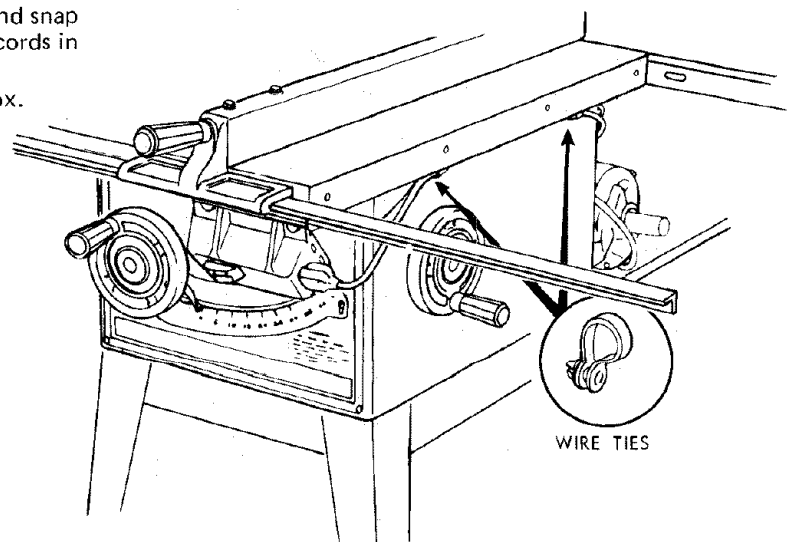

GETTING TO KNOW YOUR SAW

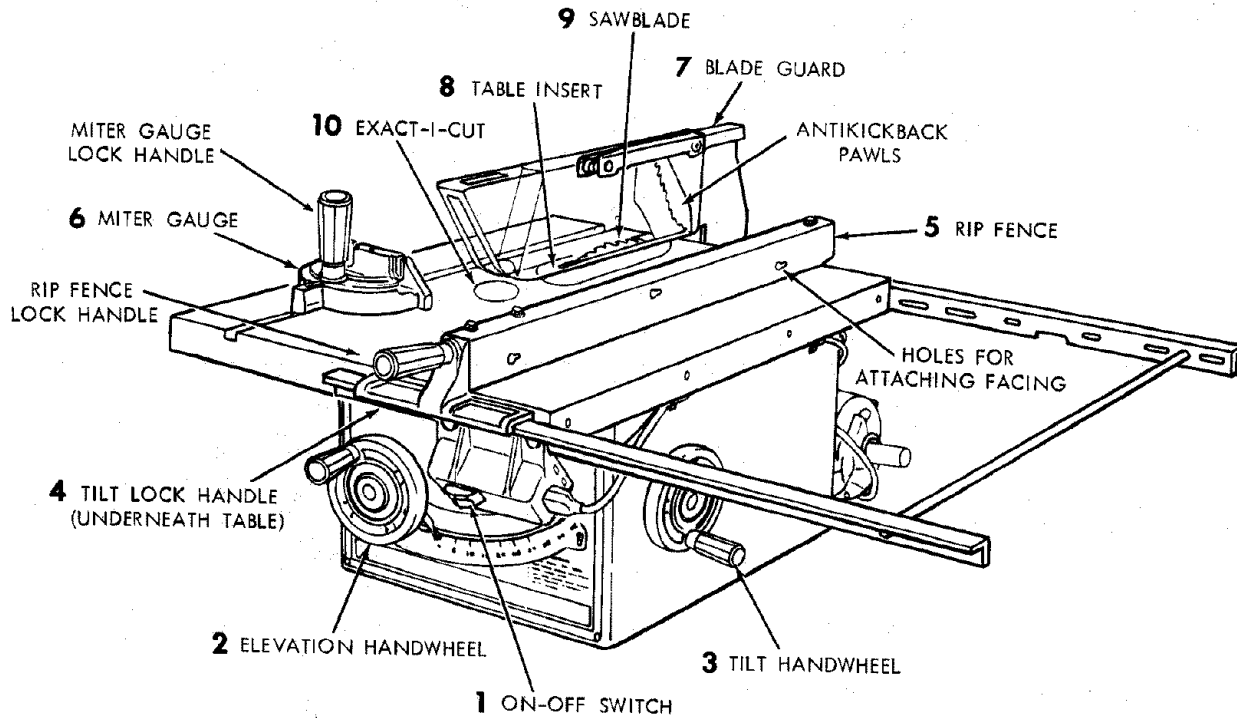

1 ON-OFF SWITCH

CAUTION: Before turning switch on, make sure the blade guard is correctly installed and operating properly.

The On-Off Switch has a locking feature. THIS FEATURE IS INTENDED TO PREVENT UNAUTHORIZED AND POSSIBLE HAZARDOUS USE BY CHILDREN AND OTHERS.

- A. TO turn saw ON ... stand to either side of the blade never in line with it ... insert finger under switch lever and pull END of lever out.

After turning switch ON, always allow the blade to come up to full speed before cutting.

Do not cycle the motor switch on and off rapidly, as this may cause the sawblade to loosen. In the event this should ever occur, allow the sawblade to come to a complete stop and retighten the arbor nut normally, not excessively. Never leave the saw while the power is "ON".

- B. TO turn saw OFF ... PUSH lever in. Never leave the saw until the cutting tool has come to a complete stop.
- C. TO lock switch in OFF position ... hold switch IN with one hand ... REMOVE key with other hand.

WARNING: FOR YOUR OWN SAFETY, LOWER BLADE OR OTHER CUTTING TOOL BELOW TABLE SURFACE. (IF BLADE IS TILTED, RETURN IT TO VERTICAL (90°) POSITION). ALWAYS LOCK THE SWITCH "OFF". WHEN SAW IS NOT IN USE ... REMOVE KEY AND KEEP IT IN A SAFE PLACE ... ALSO ... IN THE EVENT OF A POWER FAILURE (ALL OF YOUR LIGHTS GO OUT) TURN SWITCH OFF ... LOCK IT AND REMOVE THE KEY. THIS WILL PREVENT THE SAW FROM STARTING UP AGAIN WHEN THE POWER COMES BACK ON.

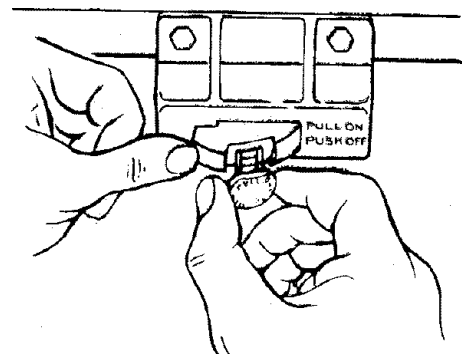
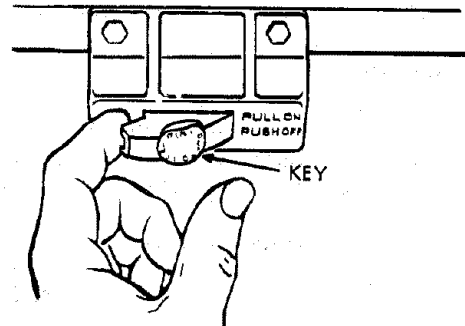
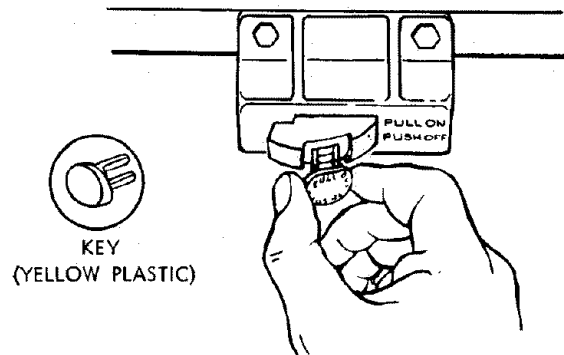

2 ELEVATION HANDWHEEL ... elevates or lowers the blade. Turn clockwise to elevate ... counterclockwise to lower.

3 TILT HANDWHEEL ... tilts the blade for bevel cutting. Turn clockwise to tilt toward left ... counterclockwise to tilt toward right.

When the blade is tilted to the LEFT as far as it will go, it should be at 45° to the table and the bevel indicator should point 45°.

NOTE: There are LIMIT STOPS inside the saw which prevent the blade from tilting beyond 45° to the LEFT and 90° to the RIGHT. (See "Adjustments" section "Blade Tilt, or Squareness of Blade to Table").

4 TILT LOCK HANDLE ... locks the blade in the desired tilt position. To loosen, turn counterclockwise. Push handle in and turn it to another position if necessary in order to tighten or loosen.

IMPORTANT: Be sure handle is hanging in the "DOWN" position before tilting blade. If it is pointing to the 1 o'clock position it may jam on underside of the table and bend the locking bolt.

5 RIP FENCE ... is locked in place by tightening the lock knob. To move the fence, loosen the knob and grasp the fence with one hand at the front.

Holes are provided in the rip fence for attaching a wood facing when using the dado head, or molding head.

Select a piece of smooth straight wood approx. 3/4" thick, at least as long as the rip fence, and at least 7-1/2" wide (high) to permit clamping of featherboards. Attach it to the fence with three Round Head #10 Wood Screws 2 in. long. To remove the facing, loosen the screws, slide the facing forward and pull the screws through the round holes.

If you are making a rip type cut in material thinner than 3/16 in. while the fence is positioned over the depressed area of table extension, the facing should be attached to the fence so that the bottom edge touches the top surface of the extension. In this case, the facing must be shorter than the fence. This will prevent thin material from sliding under the rip fence.

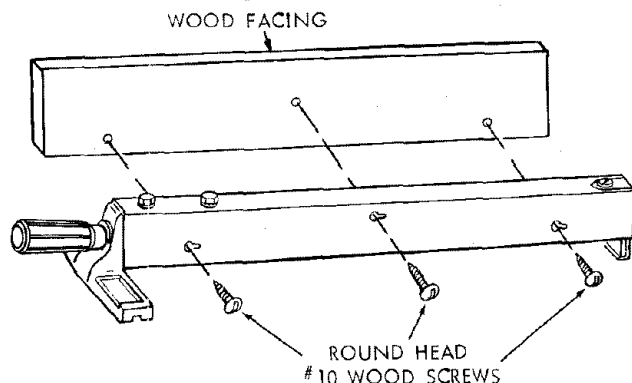

6 MITER GAUGE ... head is locked in position for crosscutting or mitering by tightening the lock knob. ALWAYS LOCK IT SECURELY WHEN IN USE.

There are two slots for the stop pin at the 45 degree right and left positions for conveniently setting the Miter Gauge to cut miters.

NOTE: The slots for the stop pin and the graduations are manufactured to very close tolerances which provide accuracy for average woodworking. In some cases where extreme accuracy is required, when making angle cuts, for example, make a trial cut and then recheck it.

If necessary, the miter gauge head can then be swiveled slightly to compensate and then locked.

Slots are provided in the miter gauge for attaching an AUXILIARY FACING to make it easier to cut long pieces. Be positive facing does not interfere with the proper operation of the sawblade guard.

Select a suitable piece of smooth straight wood ... drill two holes through it and attach it with screws.

NOTE: When bevel crosscutting, attach facing so that it extends to the right of the miter gauge and use the miter gauge in the groove to the right of the blade.

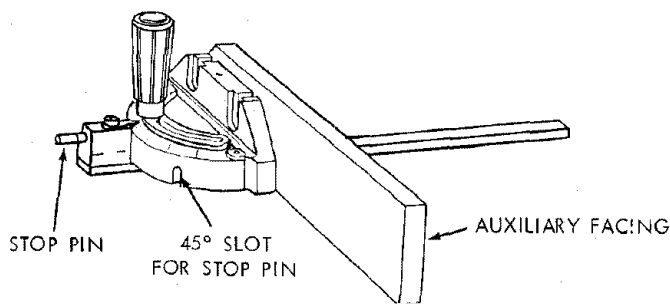

7 BLADEGUARD must always be in place and working properly for all thru-sawing cuts. That is, all cuts whereby the blade cuts completely through the workpiece.

To remove the guard for special operations, loosen the thumbscrew and slide the guard off of the rod. DO NOT DISTURB THE SETTING OF THE ROD.

When replacing the guard, make sure the PIN in the rod engages with the NOTCH in the spreader support. Make sure thumbscrew is tightened securely.

8 TABLE INSERT is removable for removing or installing blades or other cutting tools.

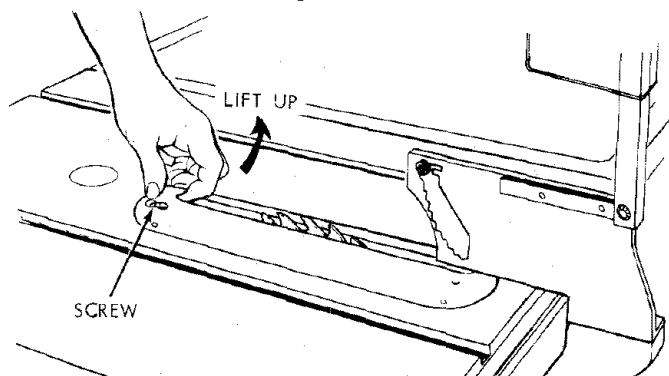

WARNING: FOR YOUR OWN SAFETY, TURN SWITCH "OFF" AND REMOVE PLUG FROM POWER SOURCE OUTLET BEFORE REMOVING INSERT.

- Lower the blade below the table surface.
- Raise blade guard.
- Loosen Screw.
- Lift insert from front end, and pull toward front of saw.

NEVER OPERATE THE SAW WITHOUT THE PROPER INSERT IN PLACE. USE THE SAW BLADE INSERT WHEN SAWING ... USE THE COMBINATION DADO MOLDING INSERT WHEN DADOING OR MOLDING.

9 REMOVING AND INSTALLING SAWBLADE.

WARNING: FOR YOUR OWN SAFETY, TURN SWITCH "OFF" AND REMOVE PLUG FROM POWER SOURCE OUTLET BEFORE REMOVING OR INSTALLING SAWBLADE.

- A. Raise Blade Guard . . . remove insert.
- B. To REMOVE blade, place a block of wood against front of blade . . . PULL arbor wrench toward you to LOOSEN arbor nut.

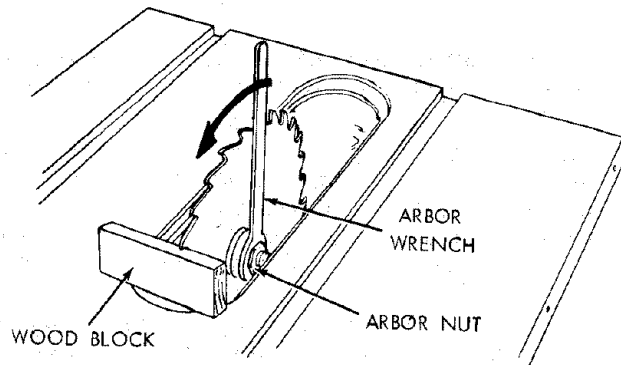

BLADE GUARD NOT SHOWN FOR PICTURE CLARITY

- C. To TIGHTEN arbor nut, place a block of wood against rear of blade . . . PUSH wrench away from you.

When installing the blade . . . make sure the teeth are pointing toward the front of the saw . . . and that the blade and collars are clean, and free from any burrs.

The HOLLOW side of the collar must be against the blade.

Always tighten the arbor nut securely.

NOTE: When using the Dado or Molding Head, it is not necessary to install the loose collar.

To replace insert.

Place insert into insert opening in table and push toward rear of saw to engage spring clip and until keyslot in insert will drop over screw. Tighten screw.

Do not tighten screw to the point where it will deflect the insert.

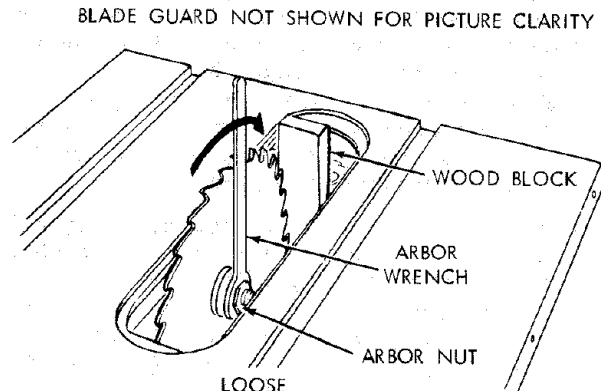

BLADE GUARD NOT SHOWN FOR PICTURE CLARITY

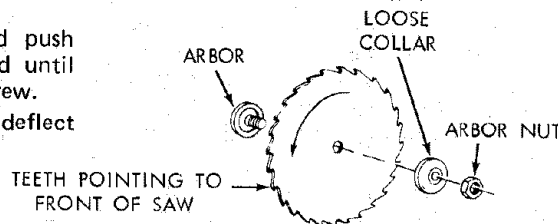

10 EXACT-I-CUT

The "yellow" plastic disc imbedded in the table in front of the sawblade, is provided for marking the location of the "sawcut" on the workpiece.

- A. Check disc . . . if it is above table surface, place a piece of hardwood on top of it and tap it down.
- B. With blade 90° (square to table) cut off a piece of wood.
- C. Pull miter gauge back until wood is over disc. Using very sharp pencil, mark a line on disc.
- D. With miter gauge in right hand groove, follow same procedure and mark another line on disc.
- E. These lines indicate the "path" of the cut (kerf) made by the sawblade.
- F. When cutting the workpiece, line up mark on workpiece with line on disc.

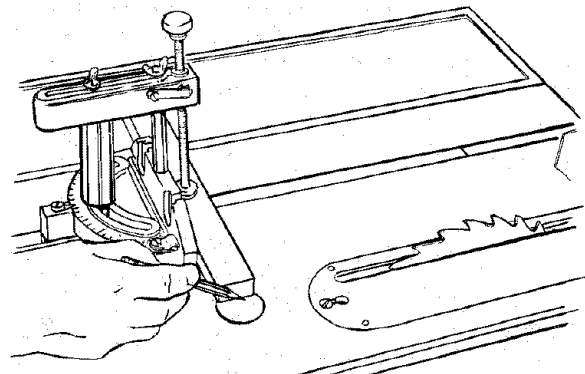

BLADE GUARD NOT SHOWN FOR PICTURE CLARITY

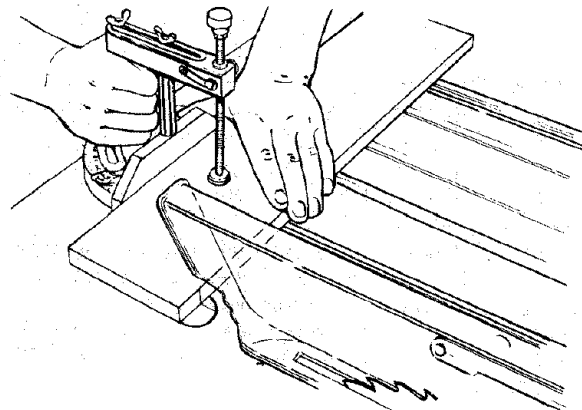

BASIC SAW OPERATION

WORK HELPERS

Before cutting any wood on your saw, study all of the "Basic Saw Operations".

Notice that in order to make some of the cuts, it is necessary to use certain devices "Work Helpers" like the Push Stick, the Push Block and the Auxiliary Fence/Work Support, which you can make yourself.

After you have made a few practice cuts, make up these "helpers" before starting any projects. Make the "Push Stick" first.

PUSH STICK AND PUSH BLOCK

Make the Push Stick using a piece of 1 x 2, or rip one from a wide board, say 11-1/2 in. wide, and set the rip fence 9-7/8 in. from the sawblade.

Make the Push Block using a piece of 3/8 in. and 3/4 in. plywood.

The small piece of wood 3/8 in. x 3/8 in. x 2-1/2 in. should be **GLUED** to the plywood . . . **DO NOT USE NAILS**. This is to prevent dulling the sawblade in the event you mistakenly cut into the push block.

Position the handle in the center of the plywood and fasten together with glue and woodscrews.

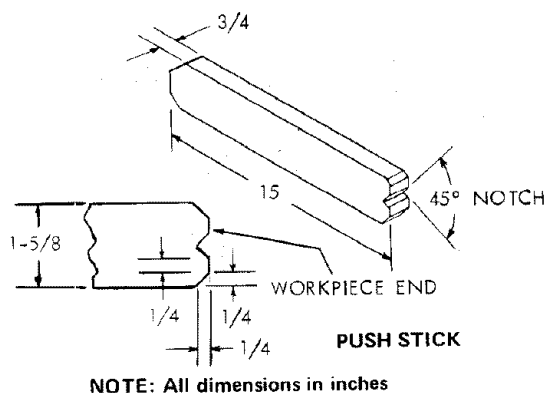

AUXILIARY FENCE/WORK SUPPORT

Make one using a piece of 3/8 in. and 3/4 in. plywood. Fasten together with glue and woodscrews.

NOTE: Since the Push Block is used with the Auxiliary Fence, the 4-3/4 in. dimensions must be held identical on both the pieces.

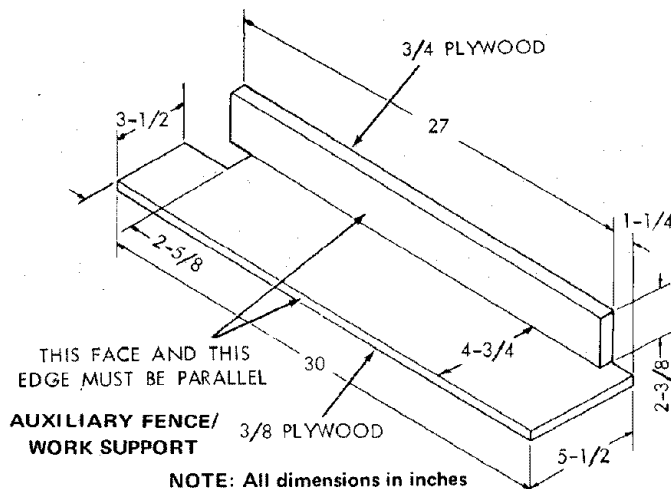
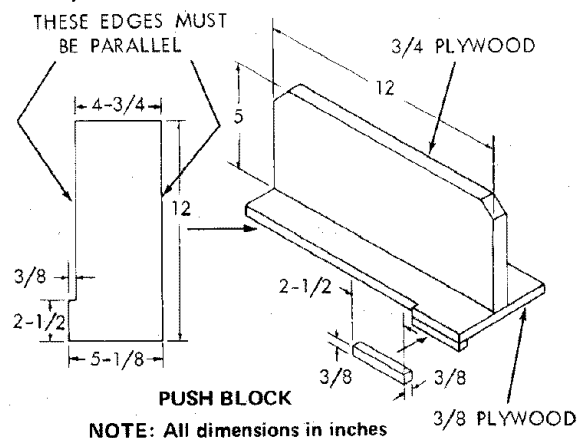

USING THE MITER GAUGE

CROSSCUTTING, MITER CUTTING, BEVEL CUTTING, COMPOUND MITER CUTTING, DADOING and when **RABBETTING AND MOLDING** across the end of a narrow workpiece, THE MITER GAUGE IS USED.

WARNING: FOR YOUR OWN SAFETY, ALWAYS OBSERVE THE FOLLOWING SAFETY PRECAUTIONS IN ADDITION TO THE SAFETY INSTRUCTIONS ON PAGES 2, 3, and 4.

1. Never make these cuts freehand (without using the miter gauge or other auxiliary devices) because the blade could bind in the cut and cause a KICKBACK or cause your fingers or hand to slip into the blade.
2. Always lock the miter gauge securely when in use.
3. Remove rip fence from table.
4. Make sure blade guard is installed for all "thru-sawing" operations (when sawblade cuts entirely thru the thickness of the workpiece.) Replace guard IMMEDIATELY after completion of dadoing, molding or rabbeting cuts.
5. Have blade extend approximately 1/8 in. above top of workpiece. Additional blade exposure would increase the hazard potential.

6. Do not stand directly in front of the blade in case of a THROWBACK (Small cut-off piece caught by the back of the blade and thrown toward the operator). Stand to either side of the blade.
7. Keep your hands clear of the blade and out of the path of the blade.
8. If blade stalls or stops while cutting, TURN SWITCH OFF before attempting to free the blade.
9. Do not reach over or behind the blade to pull the workpiece through the cut . . . to support long or heavy workpieces . . . to remove cut-off pieces of material or FOR ANY OTHER REASON.
10. Do not pick up small pieces of cut-off material from the table. REMOVE them by pushing them OFF the table with along stick. Otherwise they could be thrown back at you by the rear of the blade.
11. Do not remove small pieces of cut-off material that may become TRAPPED inside the blade guard while the saw is RUNNING. THIS COULD ENDANGER YOUR HANDS or cause a KICKBACK.
Turn the saw OFF. After the blade has stopped turning, lift the guard and remove the piece.

CROSSCUTTING

CROSSCUTTING is known as cutting wood across the grain, at 90°, or square with both the edge and the flat side of the wood. This is done with miter gauge set at "0".

The graduations on the miter gauge provide accuracy for average woodworking. In some cases where extreme accuracy is required, when making angle cuts, for example, make a trial cut and then recheck it with an accurate square, or protractor.

If necessary, the miter gauge head can be swiveled slightly to compensate for any inaccuracy.

NOTE: The space between the miter gauge bar and the groove in the table is held to a minimum during manufacturing.

For maximum accuracy when using the miter gauge, always "favor" one side of the groove in the table. In other words, don't move the miter gauge from side to side while cutting, but keep one side of the bar riding against one side of the groove.

NOTE: Glue a piece of sandpaper to the face of the miter gauge head. This will help prevent the workpiece from "creeping" while it is being cut.

The Hold-Down Clamp (Optional Accessory) included with 113.298240 should be used on the miter gauge for greater accuracy.

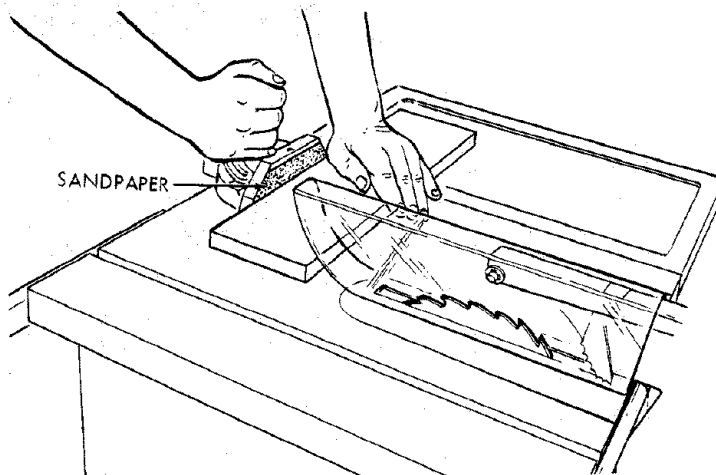

The miter gauge may be used in either of the grooves in the table. Make sure it is locked.

When using the miter gauge in the LEFT hand groove, hold the workpiece firmly against the miter gauge head with your left hand, and grip the lock handle with your right.

When using the RIGHT Hand groove, hold the workpiece with your right hand and the lockhandle with your left hand.

When cutting long workpieces, invert AUXILIARY FENCE/WORK SUPPORT and position it on top of the guide bars to support the workpiece as near to the end as possible. If this does not adequately support the workpiece, you can make a simple support by clamping a piece of plywood to a sawhorse.

Use the Hold-Down Clamp (Optional Accessory) included with 113.298240 on the miter gauge for greater accuracy.

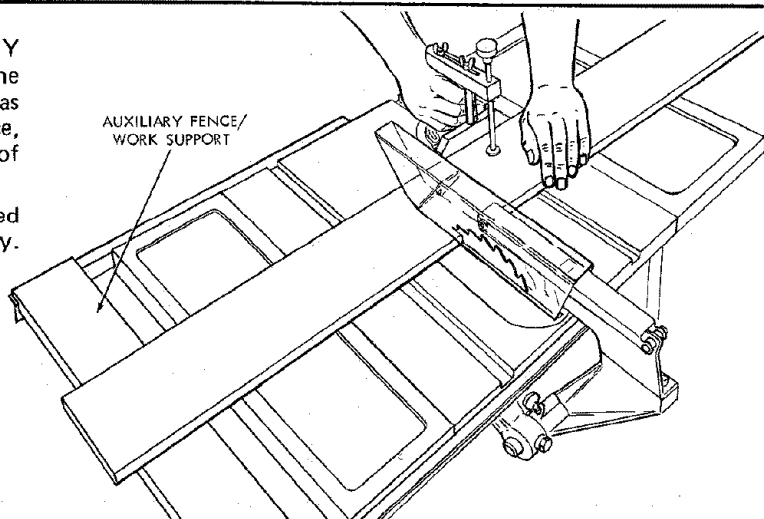

REPETITIVE CUTTING

REPETITIVE CUTTING is known as cutting a quantity of pieces the same length without having to mark each piece.

1. Use the Stop Rods (optional accessory) only for cutting duplicate pieces 6 in. long and longer.
2. DO NOT FEED workpiece with RIGHT Hand, merely guide it, making sure that it does not bind or pinch the sawblade.

When making repetitive cuts from a long workpiece, make sure it is adequately supported.

Use the Hold-Down Clamp (Optional Accessory) included with 113.298240 on the miter gauge for greater accuracy.

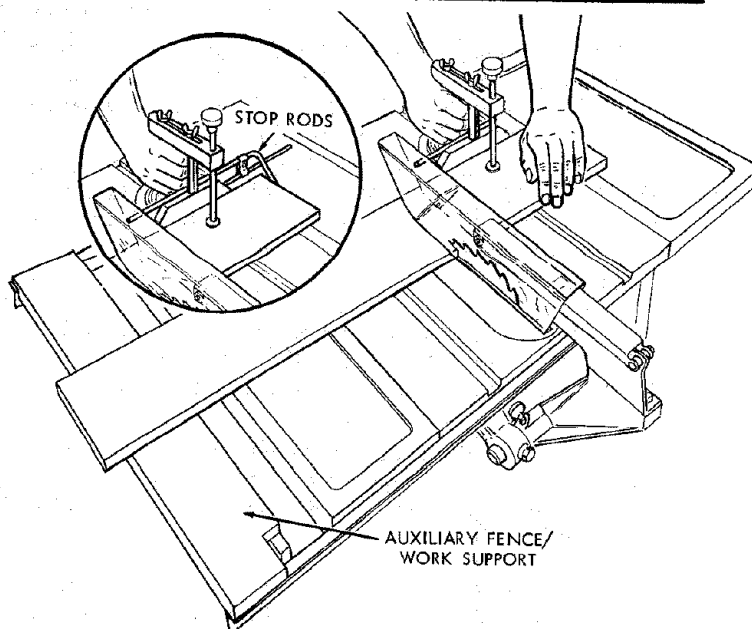

1. NEVER USE THE RIP FENCE AS A LENGTH STOP, BECAUSE THE CUTOFF PIECE COULD BIND BETWEEN THE FENCE AND THE BLADE CAUSING A KICKBACK.

2. When making repetitive cuts shorter than 6 in., clamp a block of wood 2 in. long to the table to act as a length stop. Do not clamp directly to the bottom edge of the table because the "swivel" of the clamp will not grip properly. Place a small block of wood between the bottom edge of the table and the "C" clamp.

CAUTION: When clamping the block, make sure that the end of the block is well in front of the sawblade. Be sure it is clamped securely.

3. Slide the workpiece along the miter gauge until it touches the block . . . hold it securely or clamp it with the Hold-Down Clamp (Optional Accessory) included with 113.298240.

4. Make the cut . . . pull the workpiece back . . . push the cut off piece off the table with a long push stick . . . DO NOT ATTEMPT TO PICK IT UP AS THIS COULD ENDANGER YOUR HANDS.

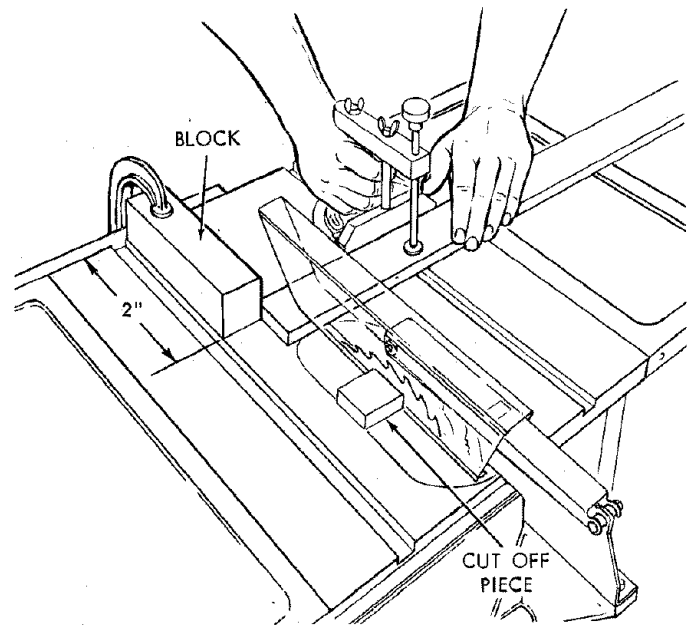

MITER CUTTING

MITER CUTTING is known as cutting wood at an angle other than 90° with the edge of the wood. Follow the same procedure as you would for crosscutting.

Adjust the miter gauge to the desired angle, and lock it.

The miter gauge may be used in either of the grooves in the table.

When using the miter gauge in the LEFT Hand groove, hold the workpiece firmly against the miter gauge head with your left hand, and grip the lock knob with your right.

When using the RIGHT hand groove, hold the workpiece with your right hand and the knob with your left hand.

Use the Hold-Down Clamp (Optional Accessory) included with Model 113.298240 on the miter gauge for greater accuracy.

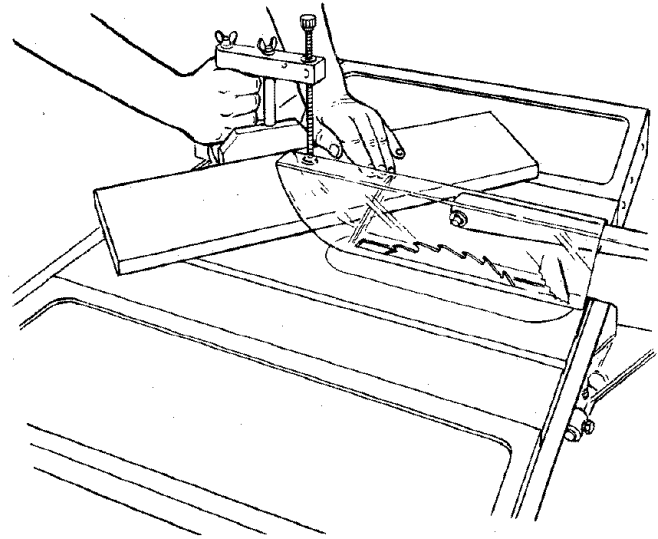

BEVEL CROSSCUTTING

BEVEL CROSSCUTTING is the same as crosscutting except that the wood is also cut at an angle . . . other than 90° with the flat side of the wood.

Adjust the blade to the desired angle.

Use the Miter Gauge in the groove to the RIGHT of the blade. It cannot be used in the groove to the LEFT because the blade guard will interfere. Hold the workpiece with your right hand and the lockhandle with your left hand.

Use the AUXILIARY FENCE/WORK SUPPORT for additional support of the workpiece.

Lay it across the guide bars to support the workpiece as near to the end as possible.

Use the Hold-Down Clamp (Optional Accessory) included with Model 113.298240 on the miter gauge for greater accuracy.

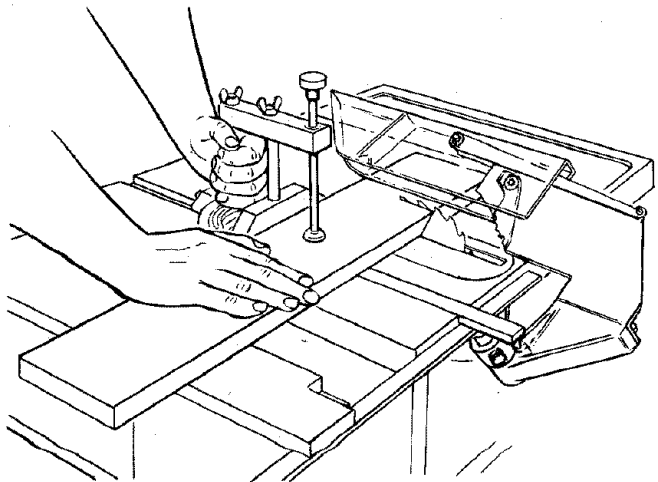

COMPOUND MITER CUTTING

COMPOUND MITER CUTTING is a combination of miter cutting and bevel crosscutting. The cut is made at an angle other than 90° to both the edge and the flat side of the wood.

Adjust the miter gauge and the blade to the desired angle . . . Make sure miter gauge is locked.

USING THE HOLD-DOWN

When cutting wide pieces of material, move the clamp assembly forward as far as it will go . . . grip the lock handle and tighten by turning clockwise until lock handle is secured. Tighten both wing screws.

When cutting narrow pieces of material, adjust the clamp assembly with the clamp over the center of the workpiece. Grip the lock handle and tighten by turning clockwise until lock handle is secured. Tighten both wing screws.

The clamp screw contains a "rapid approach" feature. Disengage clamp lock latch, press IN the rapid approach button which is located on the left side of the clamp assembly and PUSH DOWN or PULL UP on the clamp screw. Release button and tighten the clamp screw. Engage clamp lock latch.

FOR YOUR PROTECTION, NEVER USE MITER GAUGE WITH CLAMP LOCK LATCH DISENGAGED.

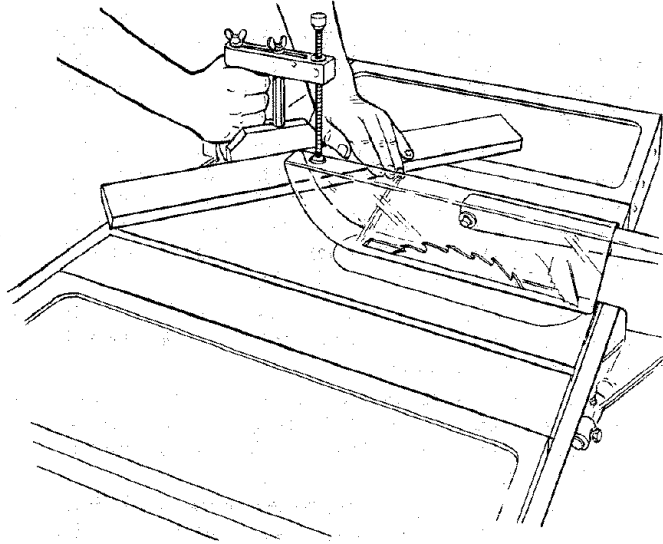

SUPPORT LONG WORKPIECES . . . you can make a simple support by clamping a piece of plywood to a sawhorse.

ADD FACING to front face of miter gauge head for support as needed. It must not extend past the right end — including the 45° corner — of miter gauge head when miter gauge is used in the left table groove, nor past the left end when miter gauge is used in the right table groove. Otherwise, the **FACING** will interfere with the saw blade guard and prevent proper and safe operation.

CAUTION: For bevel crosscutting or compound miter cutting, use the miter gauge in the groove to the **RIGHT** of the blade . . . **NEVER TO THE LEFT.** This will permit the guard and the miter gauge to function properly.

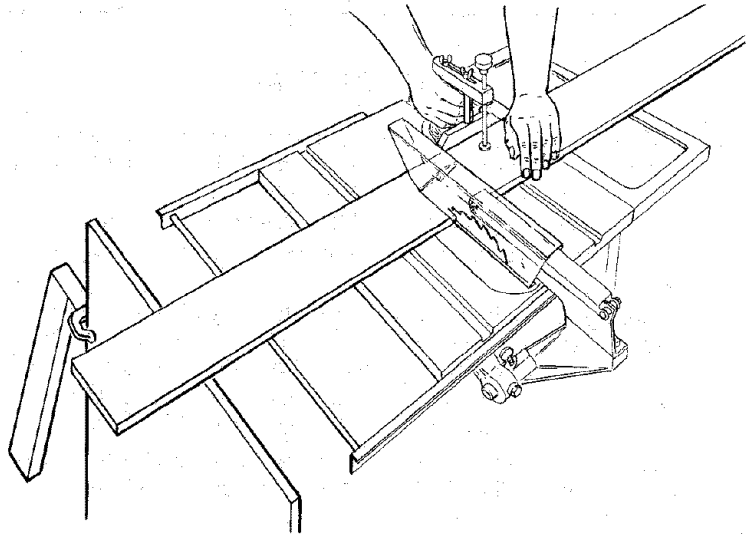

Always release clamping knob — unclamp workpiece and disengage clamp lock latch before pressing in rapid approach button.

End of workpiece must extend at least two inches to either side of shoe of clamp screw.

Wide (12" or wider) and long (2 feet or longer) pieces of plywood, chip board or wall paneling should be cut using the rip fence rather than the miter gauge.

NOTE: It may be necessary to add a facing to the Fence to prevent very thin materials like wall paneling or formica from slipping under the fence. Support wide workpieces to the rear of the table — you can make a sample support by clamping a piece of plywood to a sawhorse.

BE POSITIVE edge of workpiece next to face of miter gauge head is straight and tight against miter gauge head so that workpiece does not rock or rotate.

When repositioning Head to another miter angle, it is necessary to loosen both Wing Screws slightly before loosening the Lock Handle.

CAUTION: After setting angle, secure **Lock Handle** and **both Wing Screws**, in that order, before clamping the workpiece and engaging the clamp lock latch.

ALWAYS use both hands when operating with miter gauge. Place one hand on the lock handle — use this hand to feed

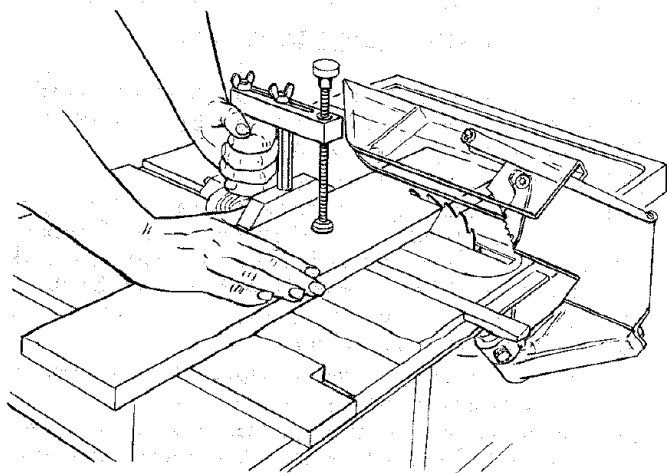

workpiece thru the sawblade. **For narrow work**, place other hand so thumb is hooked behind miter gauge head and fingers hooked over leading edge for work. For wider work where other hand cannot span board as above, place hand on top of work and hook fingers over leading edge of work to hold it tight against the face of the miter gauge during the cutting operation.

Never use miter gauge with clamp lock latch disengaged.

USING THE RIP FENCE

RIPPING, BEVEL RIPPING, PLOUGHING, MOLDING, RESAWING AND RABBETING are performed using the RIP FENCE together with the AUXILIARY FENCE/WORK SUPPORT, PUSH STICK OR PUSH BLOCK.

WARNING: FOR YOUR OWN SAFETY, ALWAYS OBSERVE THE FOLLOWING SAFETY PRECAUTIONS IN ADDITION TO THE SAFETY INSTRUCTIONS ON PAGES 2, 3, and 4.

1. Never make these cuts **FREEHAND** (without using the rip fence or auxiliary devices when required) because the blade could bind in the cut and cause a **KICKBACK**.
2. Always lock the rip fence securely when in use.
3. Remove miter gauge from table.
4. Make sure blade guard is installed for all thru-sawing type cuts. Replace the guard **IMMEDIATELY** following completion of resawing, rabbeting, dadoing, or molding operations.
Frequently check the action of the **ANTIKICKBACK PAWLS** by passing the workpiece alongside of the spreader while saw is **OFF**.
Pull the workpiece **TOWARD** you. If the **PAWLS** do not **DIG** into the workpiece and **HOLD** it ... the pawls must be **SHARPENED**. See "Maintenance" section.
5. Have blade extend approximately 1/8 in. above top of workpiece. Additional blade exposure would increase the hazard potential.
6. Do not stand directly in front of the blade in case of a **KICKBACK**. Stand to either side of the blade.
7. Keep your hands clear of the blade and out of the path of the blade.
8. If the blade stalls or stops while cutting, **TURN SWITCH OFF** before attempting to free the blade.
9. Do not reach over or behind the blade to pull the workpiece through the cut ... to support long or heavy workpieces ... to remove small cut-off pieces of material or **FOR ANY OTHER REASON**.
10. Do not pick up small pieces of cut-off material from the table. **REMOVE** them by pushing them **OFF** the table with a long stick. Otherwise they could be thrown back at you by the rear of the blade.
11. Do not remove small pieces of cut-off material that may become **TRAPPED** inside the blade guard while the saw is **RUNNING**. **THIS COULD ENDANGER YOUR HANDS** or cause a **KICKBACK**.
Turn the saw **OFF**. After the blade has stopped turning, lift the guard and remove the piece.

RIPPING

RIPPING is known as cutting a piece of wood with the grain, or lengthwise. This is done using the rip fence.

Position the fence to the desired **WIDTH OF RIP** and lock in place.

Before starting to rip, be sure

- A. Rip Fence is parallel to sawblade.
- B. Spreader is properly aligned with sawblade.
- C. Antikickback pawls are functioning properly.

When ripping **LONG BOARDS** or **LARGE PANELS**, always use a work support.

A simple one can be made by clamping a piece of plywood to a sawhorse.

BEVEL RIPPING

When bevel ripping material 6 in. or narrower, use fence on the right side of the blade **ONLY**. This will provide more space between the fence and the sawblade for use of a push stick. If the fence is mounted to the left, the sawblade guard may interfere with proper use of a push stick.

When "**WIDTH OF RIP**" is 6 in. and **WIDER** use your **RIGHT** Hand to feed the workpiece until it is clear of the table.

Use **LEFT** hand **ONLY** to guide the workpiece ... do not **FEED** the workpiece with the left hand.

ALWAYS SUPPORT LONG WORKPIECES

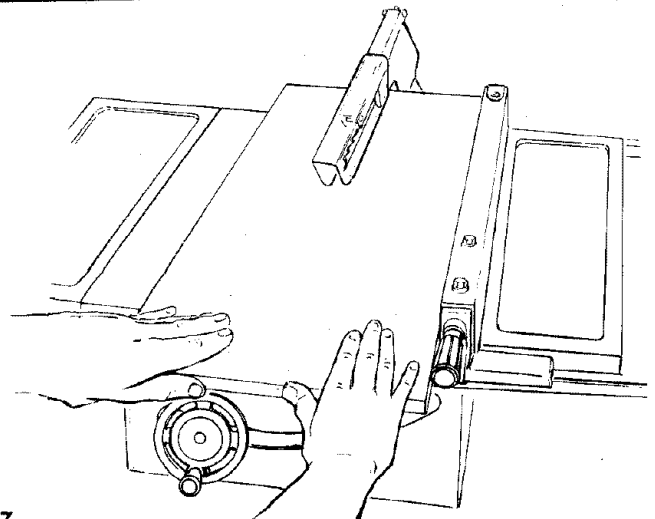
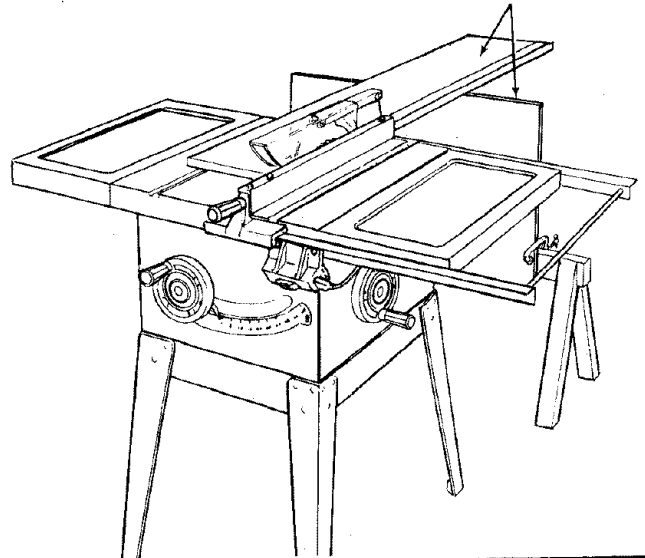

When "WIDTH OF RIP" is 2 in. to 6 in. wide USE THE PUSH STICK to feed the work.

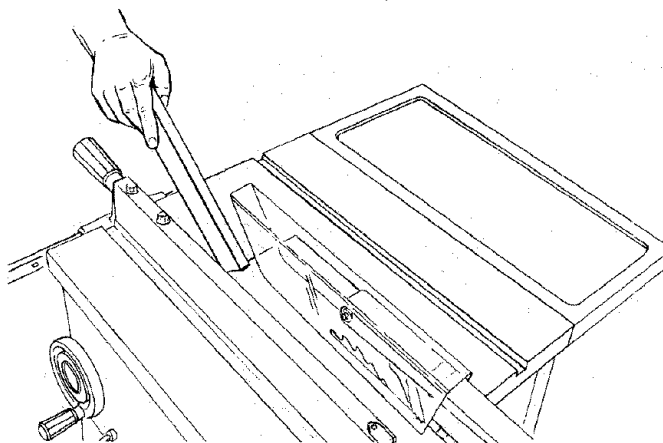

When WIDTH OF RIP is NARROWER than 2 in., the push stick CANNOT be used because the guard will interfere . . . USE the AUXILIARY FENCE/WORK SUPPORT and PUSH BLOCK.

Attach Auxiliary Fence/Work Support to rip fence with two "C" clamps.

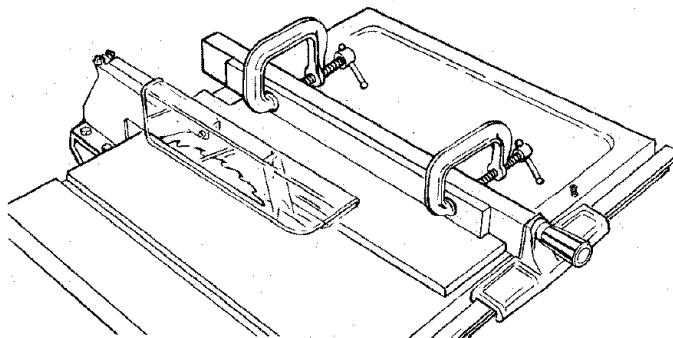

Feed the workpiece by hand along the AUXILIARY FENCE until the end is approx. 1 in. past the front edge of the table. Continue to feed using the PUSH BLOCK.

Hold the workpiece in position and install the PUSH BLOCK by sliding it on top of the AUXILIARY FENCE/WORK SUPPORT (This May Raise Guard).

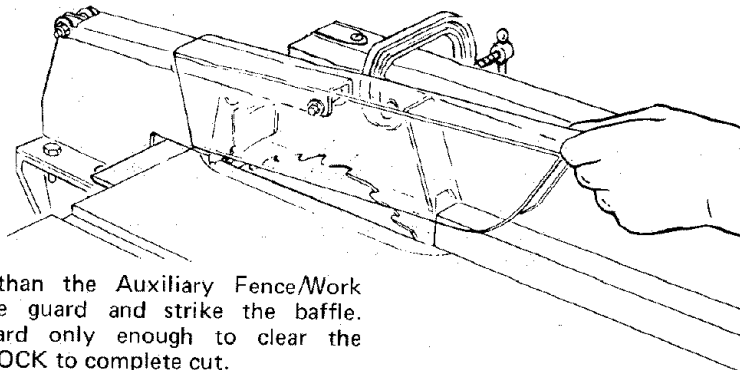
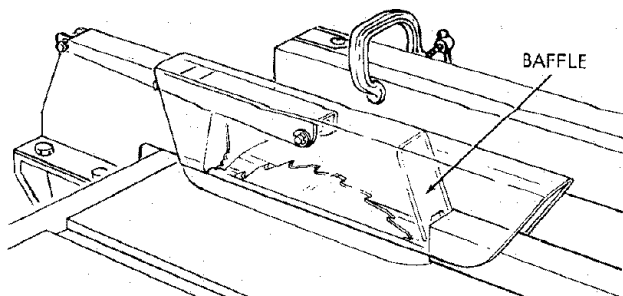
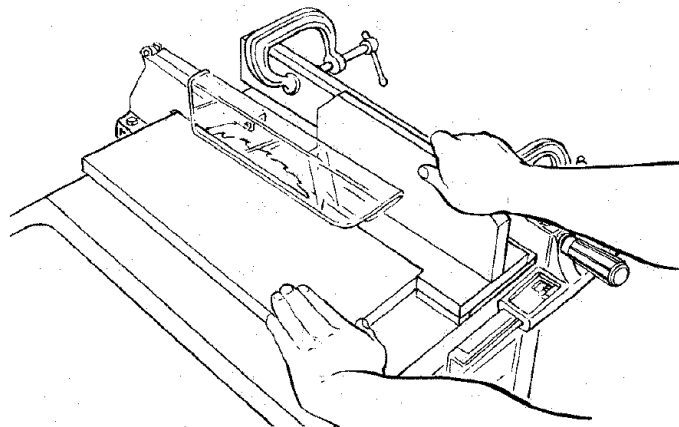

Narrow strips thicker than the Auxiliary Fence/Work Support may enter the guard and strike the baffle. CAREFULLY raise guard only enough to clear the workpiece. Use PUSH BLOCK to complete cut.

PLOUGHING AND MOLDING

PLOUGHING is grooving with the grain the long way of the workpiece, using the fence. USE proper holddowns and feed devices.



MOLDING is shaping the workpiece with the grain the long way of the workpiece, using the fence. Use proper holddowns and feed devices.

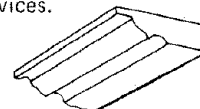

RESAWING

RESAWING is known as ripping a piece of wood through its thickness. Do not attempt to resaw BOWED or WARPED material. NOTE: To RESAW a piece of wood wider than 3-3/8 in. . . it will be necessary to remove the blade guard . . . and use the AUXILIARY FENCE/WORK SUPPORT. (See "Work Helpers").

Clamp it to the table so that the workpiece will SLIDE EASILY but not TILT or MOVE SIDeways without BINDING between the two fences.

Do not clamp directly to the bottom edge of the table because the "swivel" of the clamp will not grip properly. Place a small block of wood between the bottom edge of the table and the "C" clamp.

WARNING: FOR YOUR OWN SAFETY . . .

1. DO NOT "BACK UP" (REVERSE FEEDING) WHILE RESAWING BECAUSE THIS COULD CAUSE A KICKBACK.

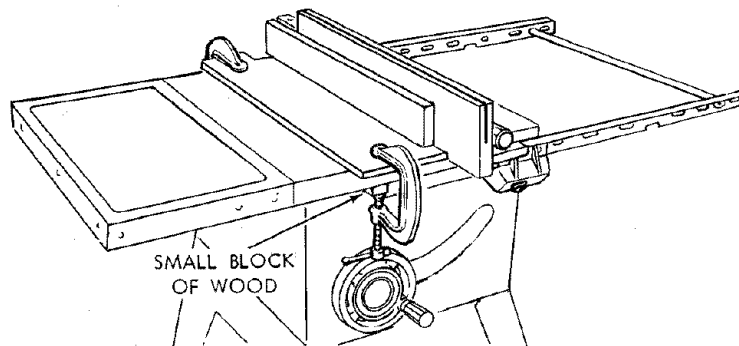

2. MAKE FIRST PASS TO A DEPTH SLIGHTLY LESS THAN ONE-HALF THE WIDTH OF THE BOARD; KEEP SAME FACE OF BOARD AGAINST FENCE FOR SECOND PASS AS THE FIRST PASS.
3. INSTALL BLADE GUARD IMMEDIATELY UPON COMPLETION OF THE RESAWING OPERATION.

CUTTING PANELS

When cutting panels (whenever fence is positioned outside of table surface), ALWAYS use the AUXILIARY FENCE/WORK SUPPORT.

1. Unlock fence and raise rear end.
2. Position AUXILIARY FENCE/WORK SUPPORT as shown and attach it with two "C" clamps.

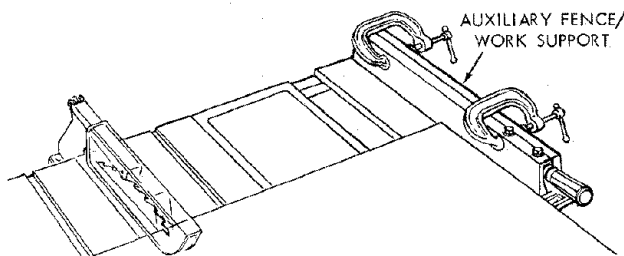

RABBETING

Rabbeting is known as cutting out a section of the corner of a piece of material, across an end or along an edge.

To make a RABBET requires cuts which do not go all the way through the material. Therefore the blade guard must be removed.

1. Remove blade guard.
2. For rabbeting along an edge (long way of workpiece) as shown, add facing to rip fence (see 5. RIP FENCE, p. 21) approximately as high as the workpiece is wide. Adjust rip fence and blade to required dimensions; then make first cut with board flat on table as any rip (type) cut; make second cut with workpiece on edge. Follow all precautions, safety instructions, and operational instructions as for ripping, or rip type operations, including feather boards and push stick, etc.
3. For rabbeting across an end, for workpiece 10½" and

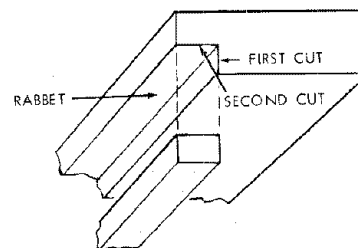

narrower make the rabbet cut with the board flat on the table using the miter gage fitted with a facing (per "6. MITER GAUGE" on p.21). DO NOT use the rip fence.

4. INSTALL BLADE GUARD IMMEDIATELY UPON COMPLETION OF RABBETING OPERATION.

Rabbet cuts can also be made using the dado head or molding head.

DADOING

Instructions for operating the Dado Head are contained in booklet furnished with the Dado Head.

The Recommended Dado Head is listed under Recommended Accessories in this manual.

The arbor on the saw, is only long enough so that the widest cut that can be made is 13/16" wide.

It is not necessary to install the outside loose collar before screwing on the arbor nut. Make sure the arbor nut is tight.

ALWAYS USE DADO INSERT LISTED UNDER RECOMMENDED ACCESSORIES.

When using the dado head it will be necessary to remove the Blade Guard and Spreader. **USE CAUTION. USE FEATHERBOARDS AND PUSH STICKS AS REQUIRED.**

ALWAYS REPLACE THE BLADE, GUARD AND SPREADER WHEN YOU ARE FINISHED DADOING.

MOLDING CUTTING

Instructions for operating the Molding Head are contained in a booklet furnished with the Molding Head.

The recommended molding head is listed under Recommended Accessories in this manual.

Always use Molding Insert Listed Under Recommended Accessories.

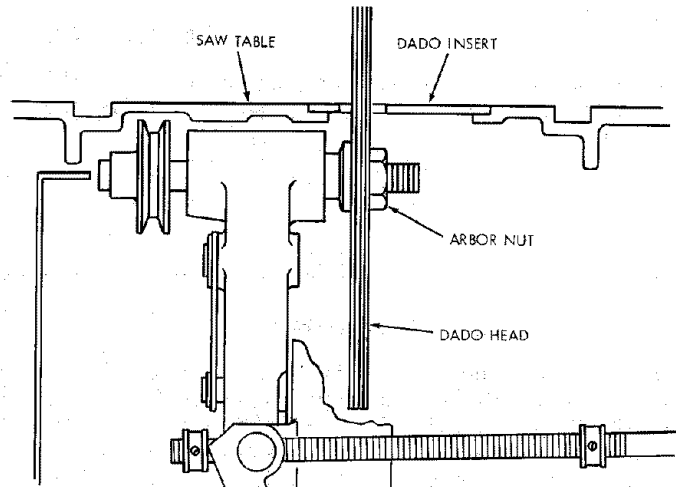

When using the molding head it will be necessary to remove the Blade Guard and Spreader. **USE CAUTION. USE FEATHERBOARDS AND PUSH STICKS, etc. AS REQUIRED.**

ALWAYS REPLACE THE BLADE GUARD AND SPREADER WHEN YOU ARE FINISHED MOLDING.

USING FEATHERBOARDS

Add 8 inch high flat facing board to the fence, the full length of the fence.

Use featherboards for all non "thru-sawing" operations (when sawblade guard must be removed). Featherboards are used to keep the work in contact with the fence and table as shown, and to stop kickbacks.

Mount featherboards to fence and table as shown, so that leading edges of featherboards will support workpiece until cut is complete, and the workpiece has been pushed completely past the cutter (sawblade, dado head, molding head, etc.) with a pushstick, as in ripping.

Before starting the operation (switch 'OFF' and cutter below table surface):

- Install featherboards so they exert pressure on the workpiece; be positive they are secure, and
- Make sure by trial that the featherboards will stop a kickback if one should occur.

Featherboards are not employed during non thru-sawing operations when using the miter gage.

Replace the sawblade guard as soon as the non thru-sawing operation is complete.

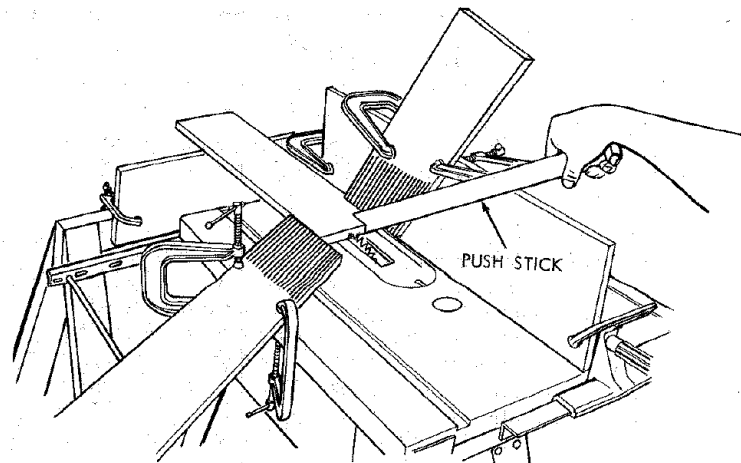
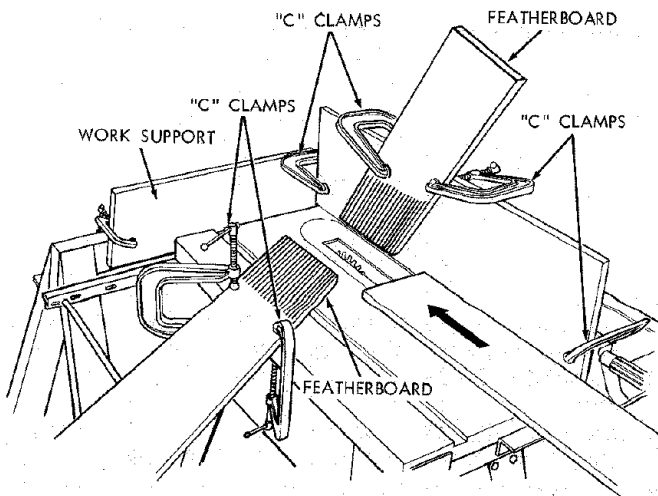

ADJUSTMENTS

WARNING: FOR YOUR OWN SAFETY, TURN SWITCH "OFF" AND REMOVE PLUG FROM POWER SOURCE OUTLET BEFORE MAKING ANY ADJUSTMENTS.

MITER GAUGE

NOTE: The slots for the stop pin and the graduations are manufactured to very close tolerances which provide accuracy for average woodworking. In some cases where extreme accuracy is required, when making angle cuts, for example, make a trial cut and then recheck it.

If necessary, the miter gauge head can be swiveled slightly to compensate for any inaccuracy.

1. Loosen the "knob" and pull "stop pin" OUT.
2. Swivel the head ... position it at "0" ... push the stop pin IN ... lock the handle.
3. The HEAD should be square with the Bar and the pointer should point to "0". Readjust the pointer if necessary.
4. If the head is not square with the bar, adjustments are required.
 - A. Loosen the "knob" (1) and the "two screws" (2)
 - B. Position the HEAD square with the BAR using a combination square.
 - C. PUSH the STOP PIN into the slot in the head at "0" ... push the pin into the slot and twist it. Lock the knob.
 - D. Recheck with the square. If the head is still not square, loosen the screws (2) and readjust the INDICATOR BLOCK.
 - E. With the head square with the bar and the pin pushed into the slot adjust the pointer (3) to point to "0".
 - F. The miter gauge head must rest on top of the bar without being able to move up and down ... yet it must swivel freely.
 - G. The swiveling movement of the head can be

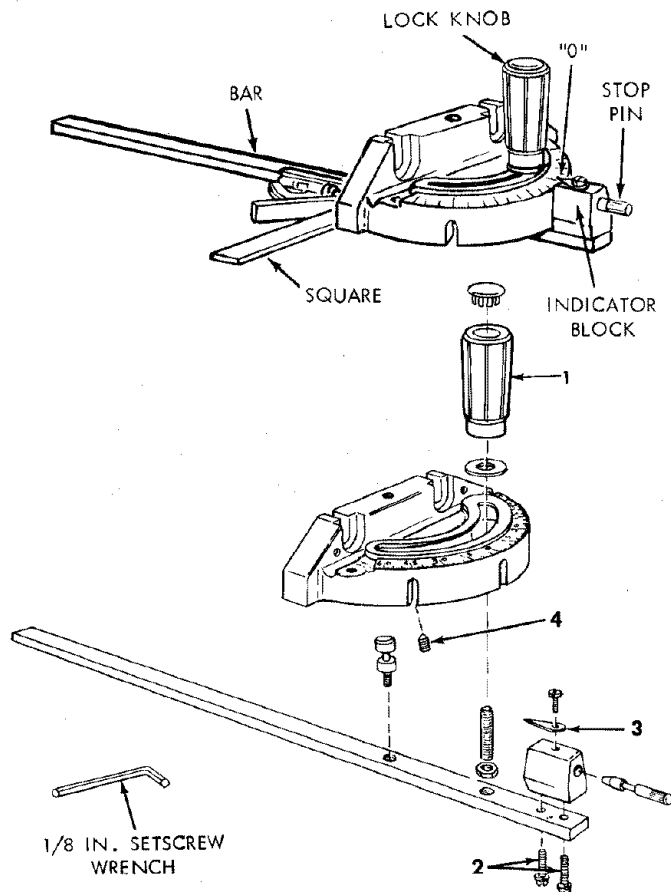

adjusted by tightening or loosening the setscrew (4) ... using the 1/8 in. setscrew wrench.

NOTE: The setscrew is located inside of the head. To reach it, swivel the head to 60 degrees and turn the miter gauge upside down.

HEELING ADJUSTMENT or PARALLELISM OF SAWBLADE TO MITER GAUGE GROOVE

While cutting, the material must move in a straight line PARALLEL to the SAWBLADE ... therefore both the miter gauge GROOVE and the RIP FENCE must be PARALLEL to the SAWBLADE.

If the sawblade IS NOT parallel to the miter gauge groove, the blade will bind at one end of the cut. (This is known as "HEELING").

To check for parallelism:

WARNING – FOR YOUR OWN SAFETY, TURN SWITCH "OFF" AND REMOVE PLUG FROM POWER SOURCE OUTLET.

1. Raise blade all the way up ... raise blade guard.
2. Mark an "x" on one of the teeth which is SET (bent) to the LEFT.
3. Place the head of a combination square in the GROOVE ... adjust blade of square so that it just touches the tip of of the MARKED tooth.
4. Move square to REAR, rotate blade to see if MARKED tooth again touches blade of square.
5. If tooth touches square at FRONT and REAR ... sawblade is PARALLEL to MITER GAUGE GROOVE.

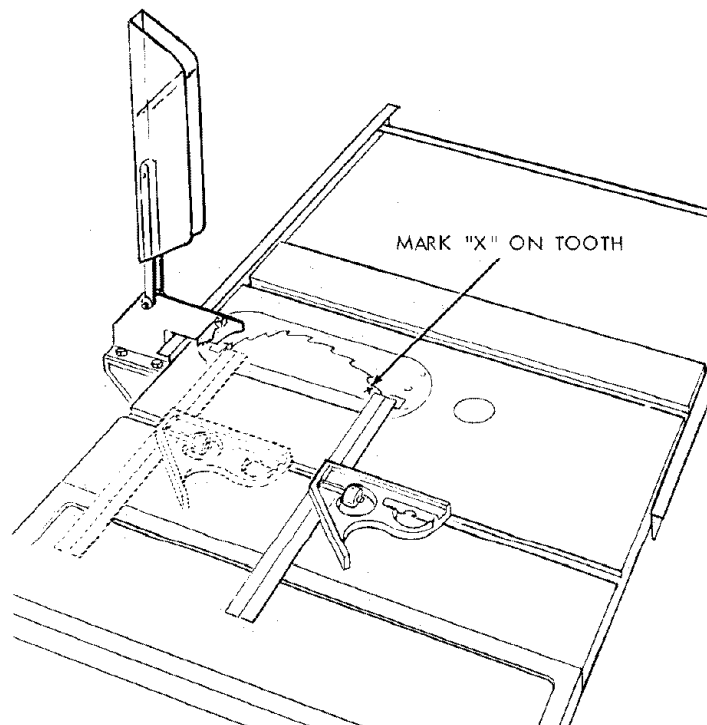

6. If tooth does not touch the same amount . . . the mechanism underneath must be adjusted to make the blade **PARALLEL** to **GROOVE**.

A. Rear trunnion must be moved **TOWARD** the combination square if there is a space between marked tooth and end of square in step 4.

B. Rear trunnion must be moved **AWAY** from the square if marked tooth pushes square out of position in the groove.

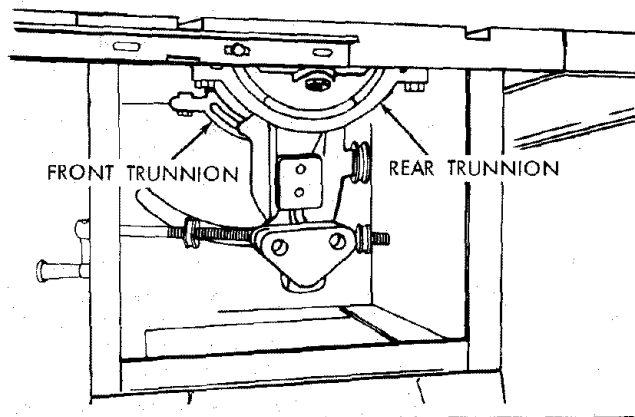

7. Loosen all three screws that hold the rear trunnion and all three screws that hold the front trunnion.

NOTE: All six screws can be reached through back of saw. Use a 9/16-in. wrench. To reach left-hand front trunnion screw, tilt blade to 45°. After loosening screws reposition blade at 90°.

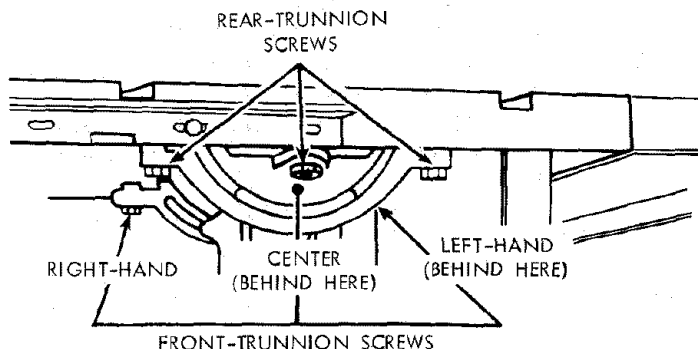

8. Using a wood block and mallet as shown, move rear trunnion to right or left as required to realign the blade. If necessary, shift front trunnion in similar manner; but do **NOT** move front trunnion unless necessary. Recheck the alignment with the square, then securely retighten all six trunnion screws.

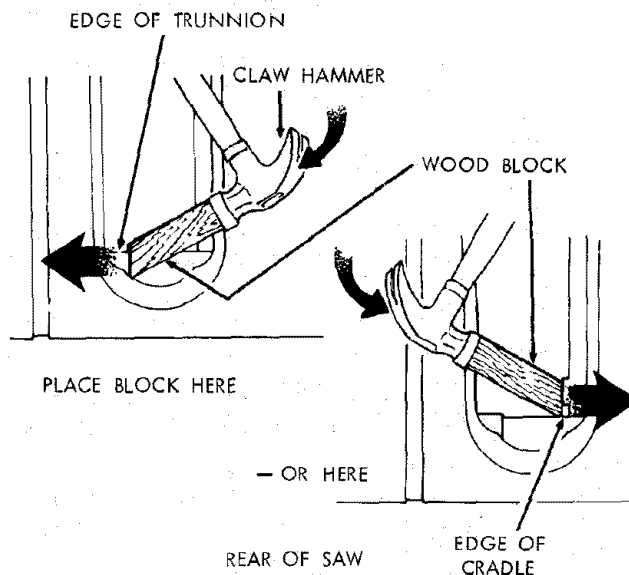

BLADE TILT, OR SQUARENESS OF BLADE TO TABLE

90° (SQUARE) and 45° (BEVEL) STOP COLLARS.

When the bevel pointer is pointing directly to the "O" mark on the bevel scale, the sawblade should make a **SQUARE** cut 90° to the table.

To check for **SQUARENESS**:

WARNING: FOR YOUR OWN SAFETY, TURN SWITCH "OFF" AND REMOVE PLUG FROM POWER SOURCE OUTLET.

1. Raise blade all the way **UP** . . . raise blade guard.
2. Place the square against blade. Make sure square is not touching the **TIP** of one of the saw **TEETH**.

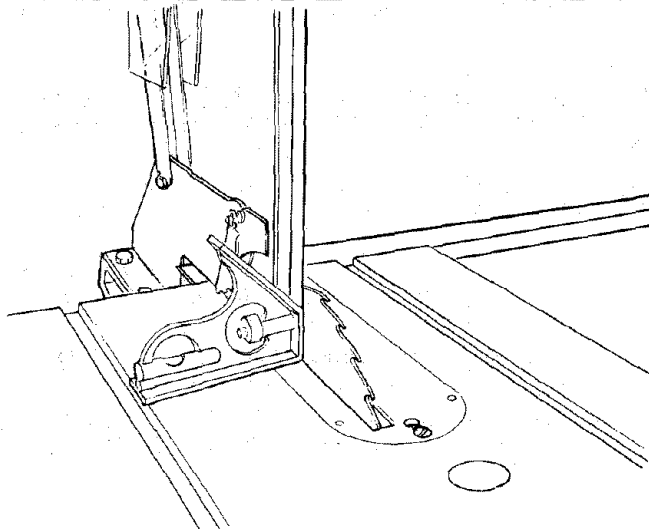

3. Operate the tilt-lock handle (COUNTERCLOCKWISE) to loosen the tilt clamp screw.
4. **NOTE:** Handle is spring loaded for engagement with screw head – must be pushed inward for disengagement whenever necessary to obtain a new grip on screw head.

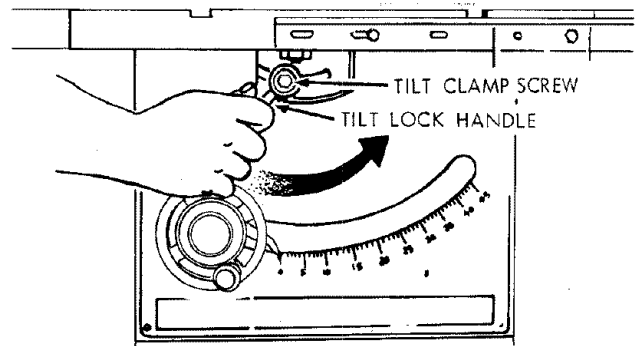

5. Rotate tilt handwheel CLOCKWISE a few turns to tilt blade. Now rotate handwheel COUNTERCLOCKWISE until it stops. Blade should now be square with table and pointer should point to "0".

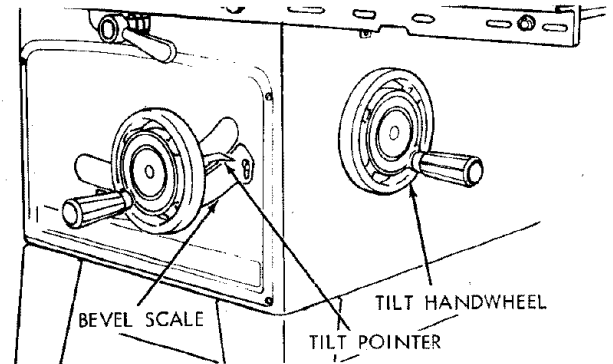

If blade is SQUARE to table;

- A. Check pointer

IF POINTER DOES NOT point to the "0" mark on the bevel scale;

- A. Remove Elevation Handwheel.
- B. Loosen screw and adjust pointer . . . using medium screwdriver.
- C. Install Elevation Handwheel.

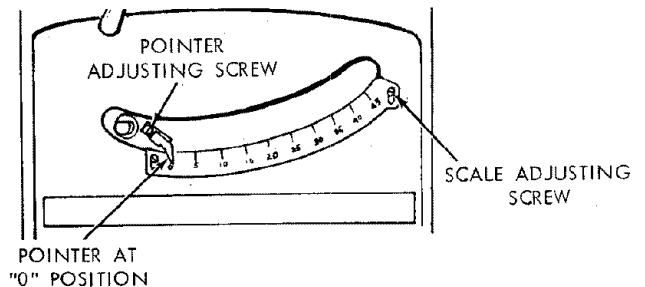

If blade is NOT SQUARE to table . . . the 90° LIMIT STOP must be ADJUSTED.

1. Using a medium size screwdriver, loosen BOTH setscrews in 90° STOP COLLAR.

NOTE: If you can't reach the setscrews, turn the TILT HANDWHEEL slightly.
2. ROTATE the STOP COLLAR moving it all the way to the end of TILT SCREW. (to the right).
3. TILT blade RIGHT or LEFT . . . checking with your square until blade is square to table.
4. ROTATE STOP COLLAR moving it to the right until it stops . . . TIGHTEN the setscrews.
5. Check POINTER. If it DOES NOT point to the "0" mark on the bevel scale. . .
 - A. Remove Elevation Handwheel.
 - B. Loosen screw and adjust pointer . . . using medium screwdriver.
 - C. Install Elevation Handwheel.

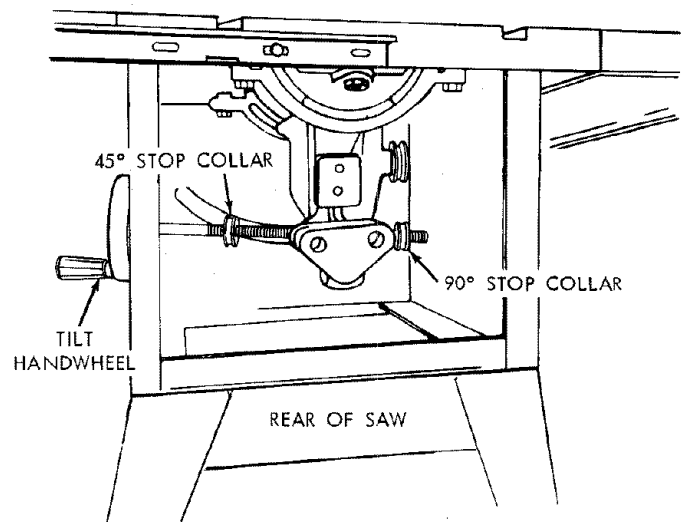

45° POSITION

TILT blade to LEFT as far as it will go. It will stop when the PIVOT NUT is against the 45° STOP COLLAR.

- A. Place an ACCURATE square against blade. Make sure square is not touching the TIP of one of the saw TEETH.

If blade is 45° to table;

- A. Check pointer.

If POINTER DOES NOT point to the 45° mark on the scale;

- A. Remove Elevation Handwheel.
- B. Loosen two screws on scale and adjust scale until POINTER points to 45° mark.
- C. Install Elevation Handwheel.

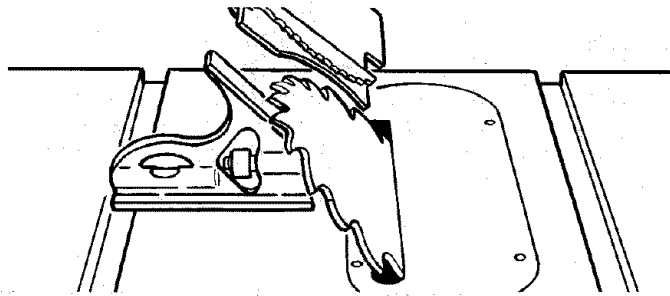

If blade is NOT 45° to table . . . the 45° STOP COLLAR and SCALE must be ADJUSTED.

1. Remove Elevation Handwheel.
2. Using a small size screwdriver, reach thru curved slot in front trim panel and loosen BOTH setscrews in 45° STOP COLLAR.

NOTE: If you can't reach the setscrews, turn the TILT HANDWHEEL slightly.

3. ROTATE the STOP COLLAR moving it IN or OUT and TILT blade RIGHT or LEFT . . . checking with your square until blade is 45° to table.

4. TIGHTEN the setscrews.

NOTE: If you can't reach the setscrews, turn TILT HANDWHEEL slightly.

5. Loosen two screws on scale and adjust scale until POINTER points to 45° mark.
6. Install Elevation Handwheel.

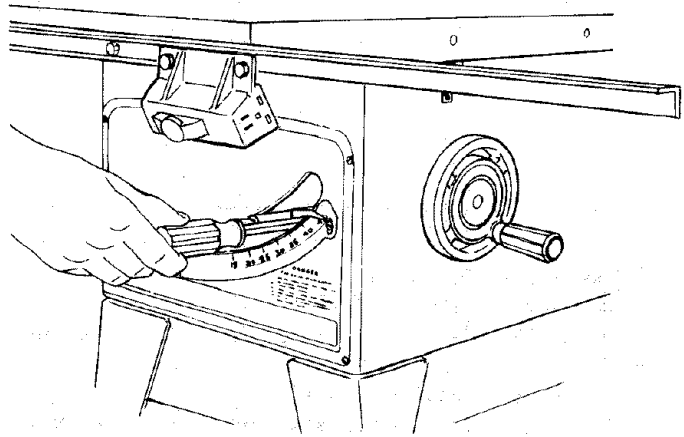

TILT MECHANISM

The handwheel should turn freely without binding. The turning action can be adjusted by tightening or loosening the screws in the bearing retainer.

NOTE: Tilt Handwheel must be removed to adjust. When adjusting the screws in the bearing retainer, hold the nut inside using a 3/8 in. wrench.

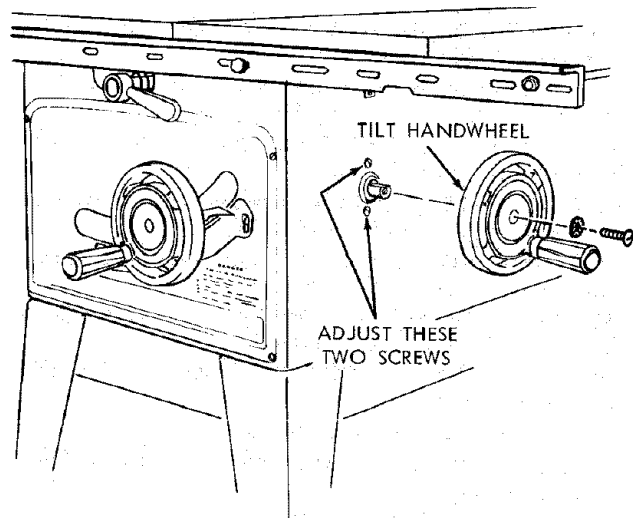

MAINTENANCE

WARNING: FOR YOUR OWN SAFETY, TURN SWITCH "OFF" AND REMOVE PLUG FROM POWER SOURCE OUTLET BEFORE MAINTAINING OR LUBRICATING YOUR SAW.

Do not allow sawdust to accumulate inside the saw. Frequently blow out any dust that may accumulate inside the saw cabinet and the motor. Frequently clean your cutting tools with Craftsman Gum and Pitch Remover.

A coat of automobile-type wax applied to the table will help to keep the surface clean and allow workpieces to slide more freely.

If the power cord is worn or cut, or damaged in any way, have it replaced immediately.

Make sure the teeth of the ANTIKICKBACK pawls are always sharp. To sharpen:

1. Remove blade guard.

2. Rotate pawl toward rear of spreader that teeth are above top of spreader.
3. Hold spreader with left hand and place pawl over corner of workbench.
4. Using a small round file (Smooth Cut) sharpen the teeth.

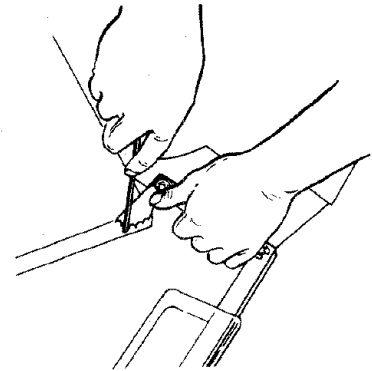

LUBRICATION

The following parts should be oiled occasionally with SAE No. 20 or No. 30 engine oil.

1. Tilt screw threads and pivot nut. (First Clean with Craftsman Gum & Pitch Remover.)
2. Elevation screw threads and pivot nut. (First Clean with Craftsman Gum & Pitch Remover.)
3. Cradle bearing points.
4. Bearing points in guard assembly, miter gauge and rip fence.

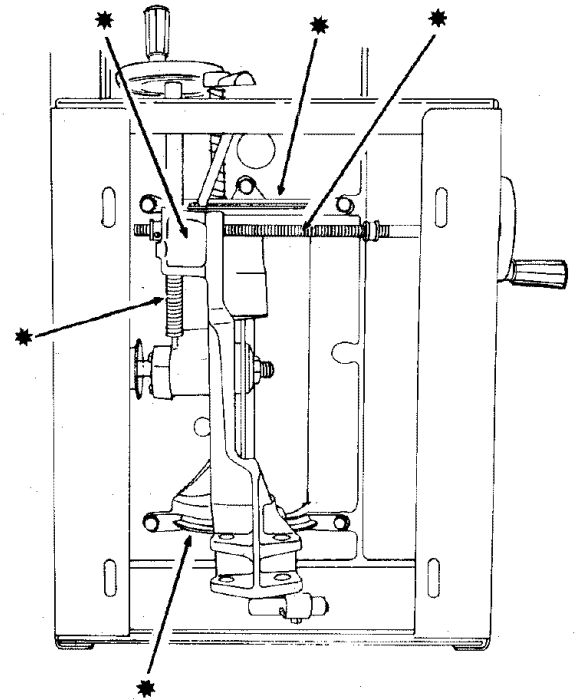
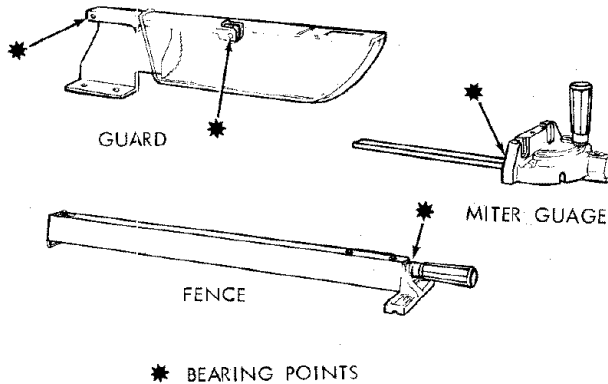

RECOMMENDED ACCESSORIES

| ITEM | CAT. NO. | ITEM | CAT. NO. |
|-------------------------------|--------------------|---|--------------------------|
| Steel Legs | 9-22235 | Work Light | 9-2481 |
| Steel Stand | 9-22214 | 7 In. Dia. Adjustable Dado Head | 9-3261 - 9-3262 - 9-3263 |
| Caster Sets | 9-22222 or 9-22221 | 7 In. Dia. Dado Head | 9-3257 |
| Solid Table Extension | 9-29957 | Sanding Wheel | 9-22723 |
| 7 In. Molding Head Set | 9-3217 | Miter-Gauge Stop Rods | 9-29924 |
| 7 In. Molding Head Set | 9-3218 | Miter-Gauge Hold-Down Clamp | 9-29928 |
| 7 In. Molding Head | 9-3214 | Taper Jig | 9-3233 |
| Molding/Dado Insert for 7 In. | | Universal Jig | 9-3235 |
| Dia. Molding or Dado Head | 9-29997 | Power Tool Know How Handbook | |
| Work Light | 9-2480 | Table Saw | 9-2918 |
| Sawdust Collection System | 9-29966 | 10-Inch Diameter Sawblades with 5/8" Bore | See Catalog |

TROUBLE SHOOTING

WARNING: FOR YOUR OWN SAFETY, TURN SWITCH "OFF" AND ALWAYS REMOVE PLUG FROM POWER SOURCE OUTLET BEFORE TROUBLESHOOTING.

TROUBLE SHOOTING -- GENERAL

| TROUBLE | PROBABLE CAUSE | REMEDY |
|---|---|--|
| Excessive vibration. | <ol style="list-style-type: none"> 1. Blade out of balance. 2. Damaged V-Belt Pulleys or poor belt. | <ol style="list-style-type: none"> 1. Discard Blade and use a different blade. 2. Replace as Indicated. |
| Cannot make square Cut when crosscutting. | <ol style="list-style-type: none"> 1. Miter gauge not adjusted properly. | <ol style="list-style-type: none"> 1. See "Adjustments" section "Miter Gauge." |
| Cut binds, burns or stalls motor when ripping. | <ol style="list-style-type: none"> 1. Dull blade with improper tooth set. 2. Blade is Heeling. 3. Warped board. 4. Rip fence not parallel to blade. 5. Spreader out of alignment | <ol style="list-style-type: none"> 1. Sharpen or replace blade. 2. See "Adjustments" section, "Heeling Adjustment . 3. Make sure concave or hollow side is facing "down," feed slowly. 4. See "Assembly" section, "Aligning Rip Fence" 5. See "Assembly" section, "Installing Blade Guard." |
| Cut not true at 90° or 45° positions. | <ol style="list-style-type: none"> 1. Stop collars not properly adjusted. | <ol style="list-style-type: none"> 1. See "Adjustments" section, "Blade Tilt, or "Squareness of Blade to Table." |
| Tilt and elevating handwheel turn hard. | <ol style="list-style-type: none"> 1. Sawdust on threads of tilt screw or elevating screw. 2. Bearing retainers to tight. | <ol style="list-style-type: none"> 1. See "Maintenance and Lubrication" section. 2. See "Maintenance" section "Tilt and Elevation Mechanism." |

TROUBLE SHOOTING -- MOTOR

NOTE: Motors used on wood-working tools are particularly susceptible to the accumulation of sawdust and wood chips and should be blown out or "vacuumed" frequently to prevent interference with normal motor ventilation.

| TROUBLE | PROBABLE CAUSE | REMEDY |
|--|---|--|
| Excessive noise. | <ol style="list-style-type: none"> 1. Motor. | <ol style="list-style-type: none"> 1. Have motor checked by qualified service technician. Repair service is available at your nearest Sears store. |
| Motor fails to develop full power. NOTE: LOW VOLTAGE: (Power output of motor decreases rapidly with decrease in voltage at motor terminals. For example, a reduction of 10% in voltage causes a reduction of 19% in maximum power output of which the motor is capable, and a reduction of 20% in voltage causes a reduction of 36% in maximum power output.) | <ol style="list-style-type: none"> 1. Circuit overloaded with lights, appliances and other motors. 2. Undersize wires or circuit too long. 3. General overloading of power company facilities. | <ol style="list-style-type: none"> 1. Do not use other appliances or motors on same circuit when using the saw. 2. Increase wire sizes, or reduce length of wiring. See "Motor Specification and Electrical Requirements" section. 3. Request a voltage check from the power company. |

TROUBLE SHOOTING -- MOTOR (Continued)

| TROUBLE | PROBABLE CAUSE | REMEDY |
|--|---|---|
| Motor starts slowly or fails to come up to full speed. | <ol style="list-style-type: none"> 1. Low voltage will not trip relay. 2. Windings burned out or open. 3. Starting relay not operating. | <ol style="list-style-type: none"> 1. Request voltage check from the power company. 2. Have motor repaired or replaced. 3. Have relay replaced. |
| Motor overheats. | <ol style="list-style-type: none"> 1. Motor overloaded. 2. Improper cooling. (Air circulation restricted through motor due to sawdust, accumulating inside of saw). | <ol style="list-style-type: none"> 1. Feed work slower into blade. 2. Clean out sawdust to provide normal air circulation through motor. See "Maintenance and Lubrication" section. |
| Starting switch in motor will not operate. | <ol style="list-style-type: none"> 1. Burned switch contacts (due to extended hold-in periods caused by low line voltage, etc.) 2. Shorted capacitor (when equipped) 3. Loose or broken connections. | <ol style="list-style-type: none"> 1. Have switch replaced and request a voltage check from the power company. 2. Have capacitor tested and replace if defective. 3. Have wiring checked and repaired. |
| Motor stalls (resulting in blown fuses or tripped circuit breakers). | <ol style="list-style-type: none"> 1. Starting switch not operating. 2. Voltage too low to permit motor to reach operating speed. 3. Fuses or circuit breakers do not have sufficient capacity. | <ol style="list-style-type: none"> 1. Have switch replaced. 2. Request voltage check from the power company. 3. Install proper size fuses or circuit breakers. |
| Frequent opening of fuses or circuit breakers. | <ol style="list-style-type: none"> 1. Motor overloaded. 2. Fuses or circuit breakers do not have sufficient capacity. 3. Starting switch not operating (motor does not reach speed). | <ol style="list-style-type: none"> 1. Feed work slower into blade. 2. Install proper size fuses or circuit breakers. 3. Have switch replaced. |

PARTS LIST FOR CRAFTSMAN 10 INCH TABLE SAW
 MODEL NO. 113.298142, 113.298032 & 113.298240

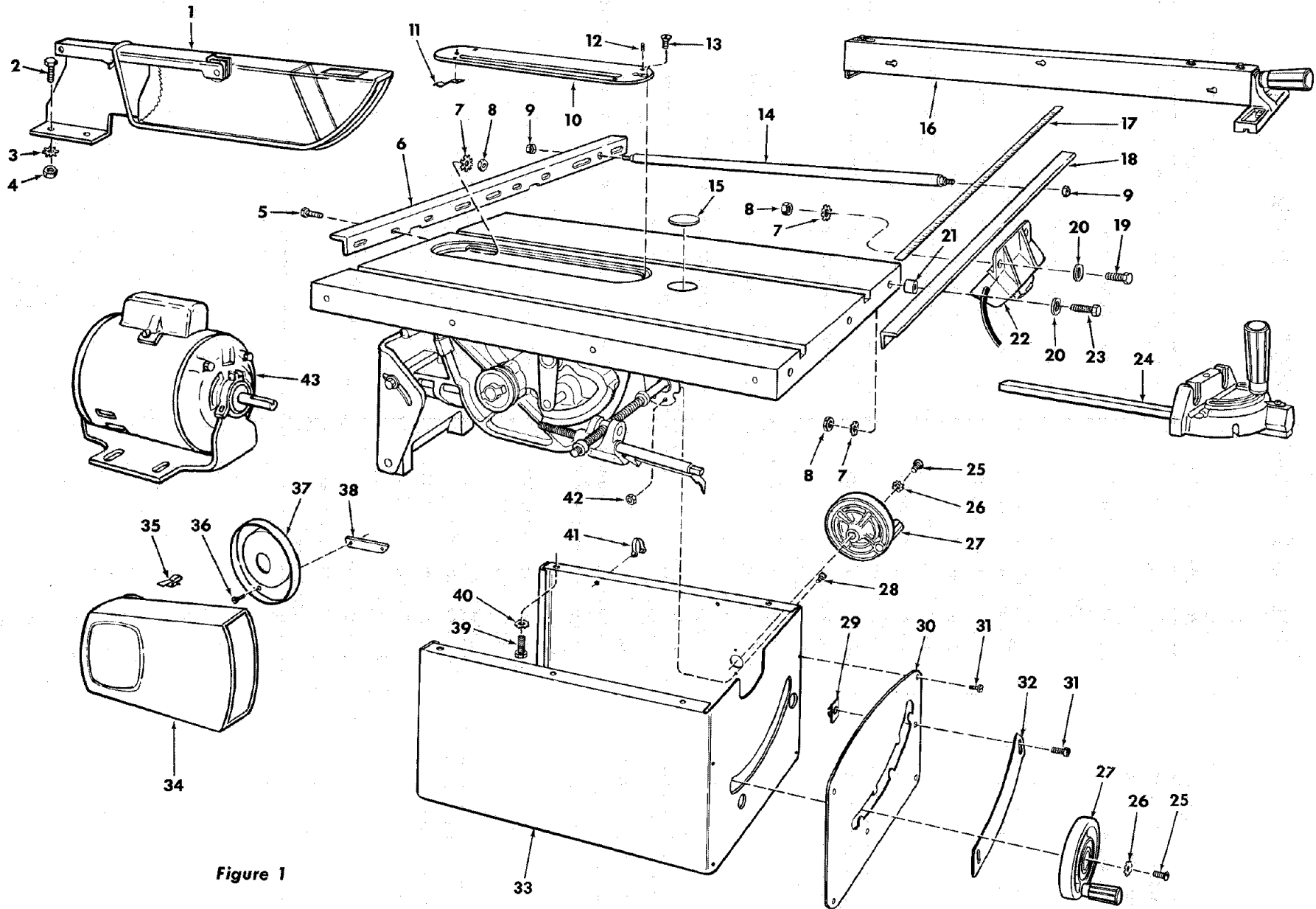

Figure 1

REPAIR PARTS

**PARTS LIST FOR CRAFTSMAN 10 INCH TABLE SAW
MODEL NO. 113.298142, 113.298032 & 113.298240**

Always order by Part Number — not by Key Number.

FIGURE 1 PARTS LIST

| Key No. | Part No. | Description | Key No. | Part No. | Description |
|---------|------------|---|---------|------------|--|
| 1 | 62579 | Guard Assembly (See Fig. 5) | 24 | 62776 | Gauge Assembly, Miter (See Fig. 4) (Model 113.298240) |
| 2 | STD522506 | *Screw, Hex Hd. 1/4-20 x 5/8 | 25 | STD 511107 | *Screw, Pan Hd. 10-32 x 3/4 |
| 3 | STD 551225 | *Lockwasher, External 1/4 | 26 | STD 551210 | *Lockwasher, External No. 10 |
| 4 | STD 541025 | *Nut, Hex 1/4-20 | 27 | 62689 | Handwheel Assembly |
| 5 | STD 523110 | *Screw, Hex 5/16-18 x 1 | 28 | STD 511103 | *Screw, Pan Hd. 10-32 x 3/8 |
| 6 | 62541 | Bar, Fence Rear | 29 | 60354 | Nut, Speed No. 8 |
| 7 | STD 551231 | *Lockwasher, External 5/16 | 30 | 62701 | Panel, Front |
| 8 | STD 541031 | *Nut, Hex 5/16-18 | 31 | STD 610805 | *Screw, Pan Hd. Ty "AB" No. 8 x 1/2 |
| 9 | 60388 | Nut, Self-threading | 32 | 62702 | Scale, Adjustable Bevel |
| 10 | 62703 | Insert Assembly, (Includes Key No. 11 & 12) | 33 | 62700 | Base |
| 11 | 62718 | Clip, Retaining | 34 | 60252 | Guard, Belt |
| 12 | STD 501102 | *Screw, Locking Set 10-32 x 3/16 | 35 | 60255 | Clip, "S" |
| 13 | 133645 | Screw, Flat Hd. 10-32 x 1 | 36 | STD 601105 | *Screw, Pan Hd. Ty "T" 10-32 x 1/2 |
| 14 | 62748 | Rod, Separation (Includes Key No. 9) | 37 | 60253 | Support, Belt Guard |
| 15 | 62493 | Insert, Exact-I-Cut | 38 | 60254 | Bracket, Support |
| 16 | 62773 | Fence Assembly, Rip (See Fig. 3) | 39 | 454896 | *Screw, Hex Hd. 3/8-16 x 1/2 |
| 17 | 62710 | Tape, Fence | 40 | STD 551237 | *Lockwasher, External 3/8 |
| 18 | 62709 | Bar Assembly, Fence Guide (Includes Key No. 17) | 41 | 71165 | Tie, Wire |
| 19 | STD 523107 | *Screw, Hex Hd. 5/16-18 x 3/4 | 42 | STD 541411 | Nut, Lock 10-32 |
| 20 | STD 551031 | *Washer, 21/64 x 5/8 x 1/16 | 43 | 62618 | +Motor (Model 113.298032) |
| 21 | 62539 | Spacer, Fence Guide Bar | 43 | 62680 | +Motor (Model 113.298240) |
| 22 | 60381 | Switch Assembly, Box (See Fig. 6) | | 62750 | Bag of Loose Parts (Not Illustrated) (Includes Bag 62751) |
| 23 | STD 523117 | *Screw, Hex, 5/16-18 x 1-3/4 | | 62751 | Bag of Loose Parts (Not Illustrated) |
| 24 | 62704 | Gauge Assembly, Miter (See Fig. 4) (Model No. 113.298142 & 113.298032) | | 62781 | Owners Manual (Not Illustrated) |

* Standard Hardware Item — May Be Purchased Locally.

NOTE: Shipping and handling charges for standard hardware items (identified by *) such as nuts, screws, washers, etc., make buying these items by mail uneconomical. To avoid shipping and handling charges, you may obtain most of these locally.

+ Stock Item — May be secured through the hardware department of most Sears Retail Stores or Catalog Order Houses.

**PARTS LIST FOR CRAFTSMAN 10 INCH TABLE SAW
MODEL NO. 113.298142, 113.298032 & 113.298240**

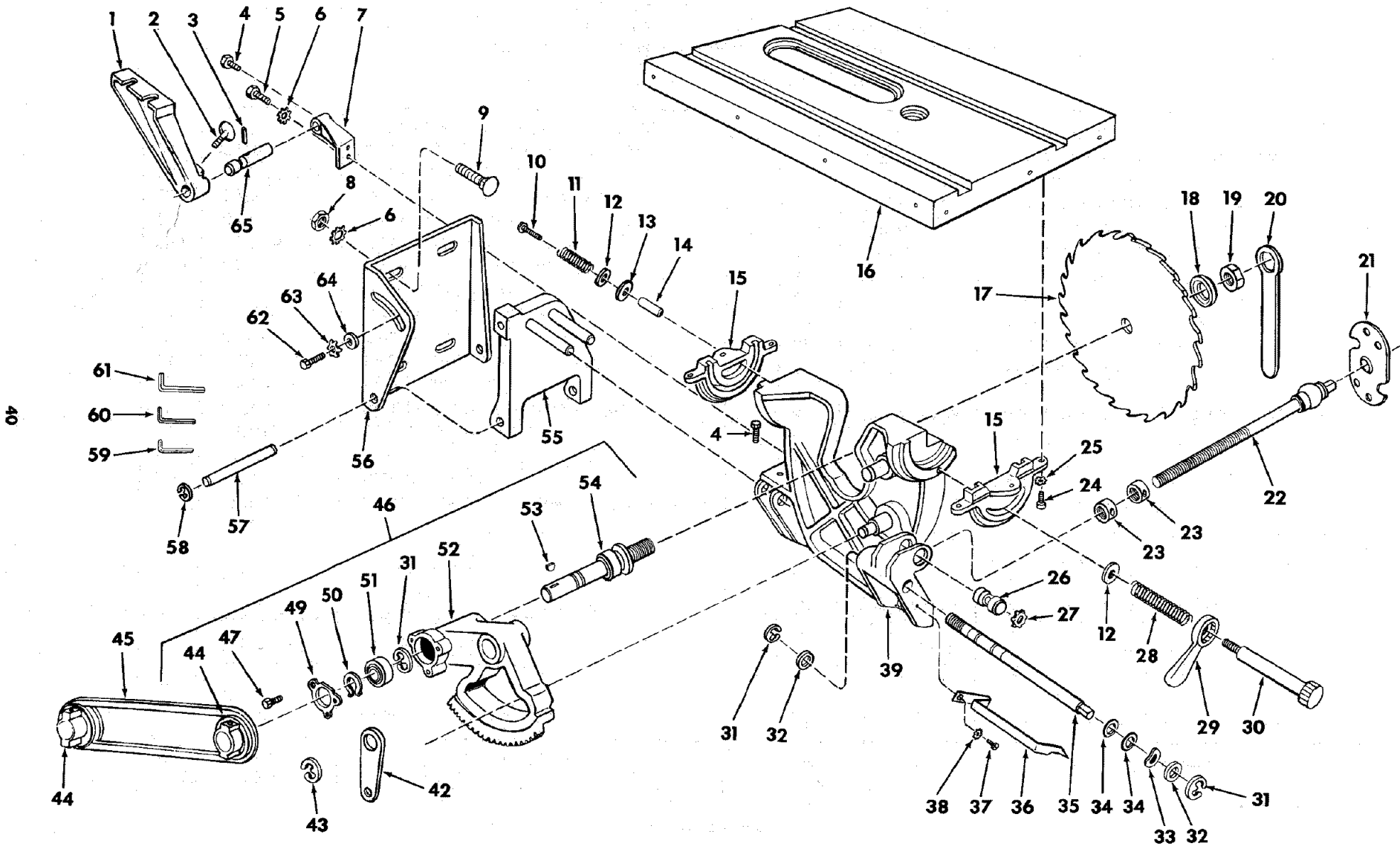

Figure 2

**PARTS LIST FOR CRAFTSMAN 10 INCH TABLE SAW
MODEL NO. 113.298142, 113.298032 & 113.298240**

FIGURE 2 PARTS LIST

| Key No. | Part No. | Description |
|---------|------------|--|
| 1 | 62587 | Support, Spreader |
| 2 | 60204 | Screw, Thumb 5/16-18 x 1 |
| 3 | STD 571812 | *Pin, Roll 3/16 x 1-1/4 |
| 4 | STD 523106 | *Screw, Hex Hd. 5/16-18 x 5/8 |
| 5 | STD 523110 | *Screw, Hex Hd. 5/16-18 x 1 |
| 6 | STD 551231 | *Lockwasher, External 5/16 |
| 7 | 62292 | Support, Guard |
| 8 | STD 541031 | *Nut, Hex 5/16-18 |
| 9 | STD 532507 | *Bolt, Carriage 5/16-18 x 3/4 |
| 10 | 60206 | *Screw, Hex Ind. Wash. Hd. 1/4-20 x 1-1/2 |
| 11 | 60205 | Spring |
| 12 | STD 551037 | *Washer, 380 x 47/64 x 3/32 |
| 13 | 63011 | Washer, Knob Clamp |
| 14 | 62295 | Spacer |
| 15 | 30426 | Table, Trunnion |
| 16 | 62696 | Table, 10 In. Saw |
| 17 | 60175 | +Blade, Saw 10 In. |
| 18 | 62498 | Collar, Blade |
| 19 | 6362 | Nut, Arbor |
| 20 | 3540 | Wrench, Arbor |
| 21 | 62437 | Retainer, Bearing |
| 22 | 62698 | Screw, Tilt |
| 23 | 37900 | Collar, Stop |
| 24 | STD 523710 | Screw, Hex Hd. 3/8-16 x 1 |
| 25 | STD 551237 | Lockwasher, External 3/8 |
| 26 | 37899 | Nut, Tilt |
| 27 | 63054 | Ring, Retaining 3/4 |
| 28 | 37828 | Spring, Clamp Screw |
| 29 | 18 | Handle, Clamp Screw |
| 30 | 37829 | Screw, Clamp |
| 31 | STD 581062 | Ring, Retaining 5/8 |
| 32 | 37838 | Washer .629 x 7/8 x 1/64 |
| 33 | 60178 | Washer, Spring |

| Key No. | Part No. | Description |
|---------|------------|--|
| 34 | STD 302111 | *O-Ring |
| 35 | 62697 | Screw, Lift |
| 36 | 62699 | Pointer |
| 37 | STD 601103 | *Screw, Pan Hd. Ty "T" 10-32 x 3/8 |
| 38 | STD 551210 | *Lockwasher, External No. 10 |
| 39 | 62489 | Cradle (Includes Key No's. 42 and 43) |
| 42 | 62312 | Link |
| 43 | 6527 | Ring, Retaining 3/4 |
| 44 | STD 328022 | *Pulley, 5/8 Bore (Includes Set Screw) |
| 45 | STD 304410 | *Belt, V 1/2 x 41 |
| 46 | 30419 | Housing, Arbor Assembly (Includes Key No's. 44, 47, 49, 50, 51, 52, 53, 54) |
| 47 | STD 600803 | *Screw, Pan Hd. Ty "T" 8-32 x 3/8 |
| 49 | 3508 | Retainer, Arbor Bearing |
| 50 | 37158 | Ring, Retaining 5/8 |
| 51 | 3509 | Bearing, Saw Arbor |
| 52 | 30420 | Housing, Arbor |
| 53 | STD 580025 | *Key, Woodruff |
| 54 | 6532 | Arbor (Includes Key No's. 31, 50, 53) |
| 55 | 37825 | Support, Motor Base |
| 56 | 37824 | Base, Motor |
| 57 | 37823 | Pin, Hinge |
| 58 | STD 581037 | Ring, Retaining 3/8 |
| 59 | 37836 | Wrench, Hex L 3/32 |
| 60 | 37887 | Wrench, Hex L 1/8 |
| 61 | 37837 | Wrench, Hex L 5/32 |
| 62 | 30628 | Screw, Pivot Arm |
| 63 | 6423 | Washer, Spring |
| 64 | STD 551025 | *Washer, 17/64 x 47/64 x 1/16 |
| 65 | 62585 | Rod, Spreader |

* Standard Hardware Item — May Be Purchased Locally.

+ Stock Item — May be secured through the Hardware Department of most Sears Retail Stores or Catalog Order Houses.

**PARTS LIST FOR CRAFTSMAN 10 INCH TABLE SAW
MODEL NO. 113.298142, 113.298032 & 113.298240**

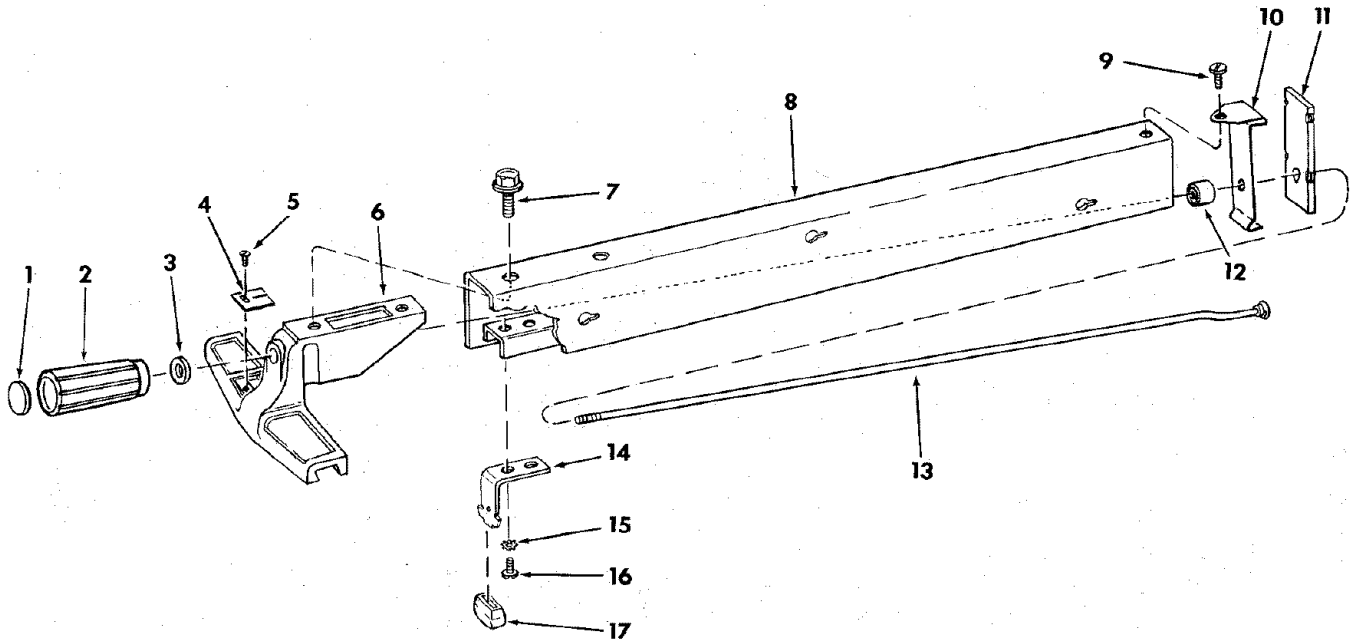
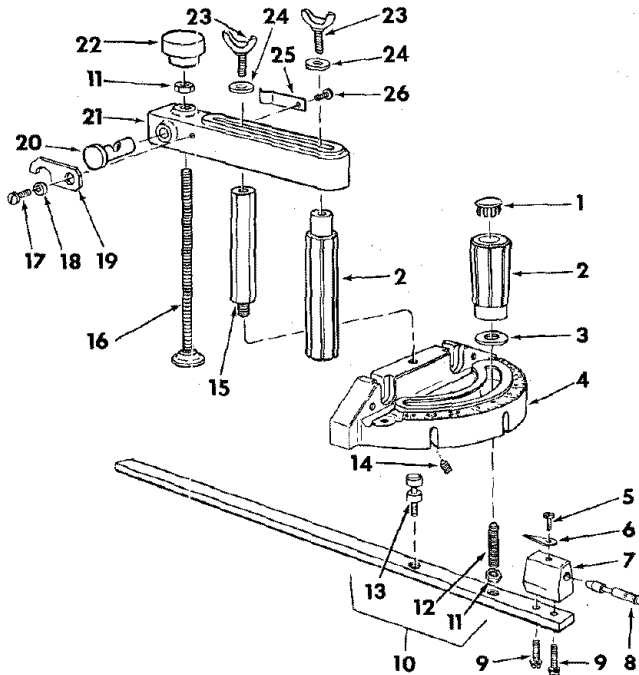

FIGURE 3 – 62773 FENCE ASSEMBLY

| Key No. | Part No. | Description |
|---------|------------|---|
| — | 62773 | Fence Assembly, Rip |
| 1 | 62693 | Plug, Button |
| 2 | 62692 | Knob (Includes Key No. 1) |
| 3 | STD 551031 | *Washer, 21/64 I.D. |
| 4 | 62775 | Indicator, Fence |
| 5 | 9404336 | *Screw, Pan Hd. Type "T" 4-40 x 1/4 |
| 6 | 62774 | Head, Fence Includes Key #4 |
| 7 | 423350 | Screw, Sems 3/8-16 x 1/2 |
| 8 | 62582 | Channel, Fence |
| 9 | STD 600805 | *Screw, Pan Hd. Type "T" 8-32 x 1/2 |
| 10 | 62528 | Spring, Fence Lock |
| 11 | 62529 | Lock, Rear Fence |
| 12 | 62531 | Roller, Rear Fence |
| 13 | 62583 | Rod, Fence Lock |
| 14 | 62533 | Spring, Head Alignment (Includes Key No. 17) |
| 15 | STD 551210 | *Lockwasher, External No. 10 |
| 16 | STD 611005 | *Screw, Type "A", Hex Ind. Sl. Wash. Hd. No. 10 x 1/2 |
| 17 | 62532 | Pad, Alignment |

* Standard Hardware Item — May Be Purchased Locally.

**PARTS LIST FOR CRAFTSMAN 10 INCH TABLE SAW
MODEL NO. 113.298142, 113.298032 & 113.298240**



**FIGURE 4 —
62704 & 62776 MITER GAUGE ASSEMBLY**

| Key No. | Part No. | Description |
|---------|------------|--|
| — | 62704 | +Gauge Assembly, Miter |
| 1 | 62693 | Plug, Button |
| 2 | 62692 | Knob, Miter Gauge (Includes Key No. 1) |
| 2 | 37897 | Handle, Miter Gauge (Model 113.298240 Only) |
| 3 | STD 551031 | *Washer, Plain, 21/64 x 1 x 1/16 |
| 4 | 37893 | Gauge, Miter |
| 5 | STD 510803 | *Screw, Pan Hd. 8-32 x 5/16 |
| 6 | 135 | Indicator |
| 7 | 37895 | Block, Miter Gauge Indicator |
| 8 | 37896 | Pin, Miter Gauge Stop |
| 9 | 9417295 | *Screw, Pan Hd., w/Lockwasher, 8-32 x 5/8 |
| 10 | 62230 | Rod Assembly, Miter Gauge, Consisting of Items 11, 12, 13 |
| 11 | STD 541231 | *Nut, Hex., 5/16-18 |
| 12 | 62225 | Stud, Clamp |
| 13 | 62383 | Stud, Pivot |
| 14 | 60288 | Screw, Locking Set 1/4-20 x 3/8 |
| 15 | 37857 | Rod, Support |
| 16 | 62780 | Screw, Clamp Assembly |
| 17 | STD 601103 | *Screw, Pan Hd. Ty "T" 10-32 x 3/8 |
| 18 | 60425 | Bushing |
| 19 | 62779 | Latch, Clamp Lock |
| 20 | 62778 | Lock, Clamp |
| 21 | 62777 | Support, Clamp |
| 22 | 62482 | Knob |
| 23 | 37858 | Screw, Wing 1/4-20 x 1 |
| 24 | 9414920 | Washer, 17/64 x 5/8 x 1/16 |
| 25 | 37841 | Clip |
| 26 | STD 600803 | *Screw, Pan Hd. Ty "T" 8-32 x 5/16 |

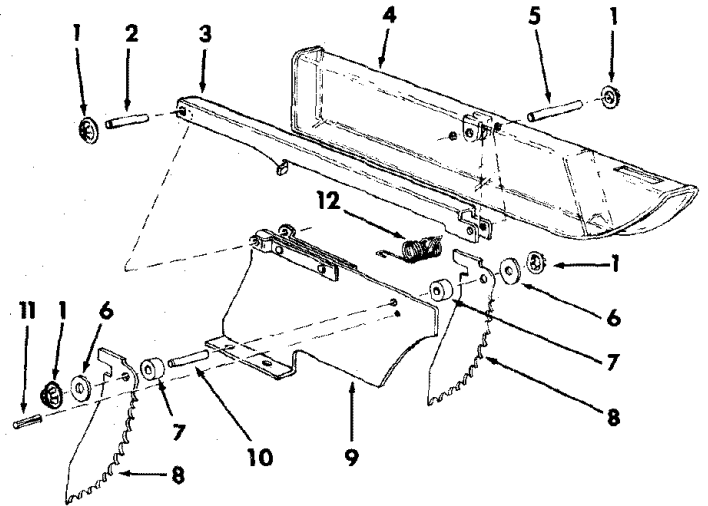

FIGURE 5 — 62579 GUARD ASSEMBLY

| Key No. | Part No. | Description |
|---------|------------|------------------------------|
| — | 62579 | Guard Assembly, Saw |
| 1 | 60297 | Nut, Push |
| 2 | 62391 | Pin 1/4 x 1-1/2" |
| 3 | 62395 | Support, Guard |
| 4 | 62389 | Guard, Saw |
| 5 | 62390 | Pin, 1/4 x 1-3/4" |
| 6 | STD 551025 | *Washer, 17/64 x 5/8 x 1/16" |
| 7 | 62520 | Spacer, Pawl |
| 8 | 62396 | Pawl |
| 9 | 62580 | Spreader, Assembly Blade |
| 10 | 62410 | Pin, 1/4 x 1" |
| 11 | STD 571810 | *Pin, Roll, 3/16 x 15/16" |
| 12 | 62519 | Spring, Pawl |

* Standard Hardware Item — May Be Purchased Locally

+ Stock Item — May be secured through the Hardware Department of most Sears Retail Stores or Catalog Order Houses.

**PARTS LIST FOR CRAFTSMAN 10 INCH TABLE SAW
MODEL NO. 113.298142, 113.298032 & 113.298240**

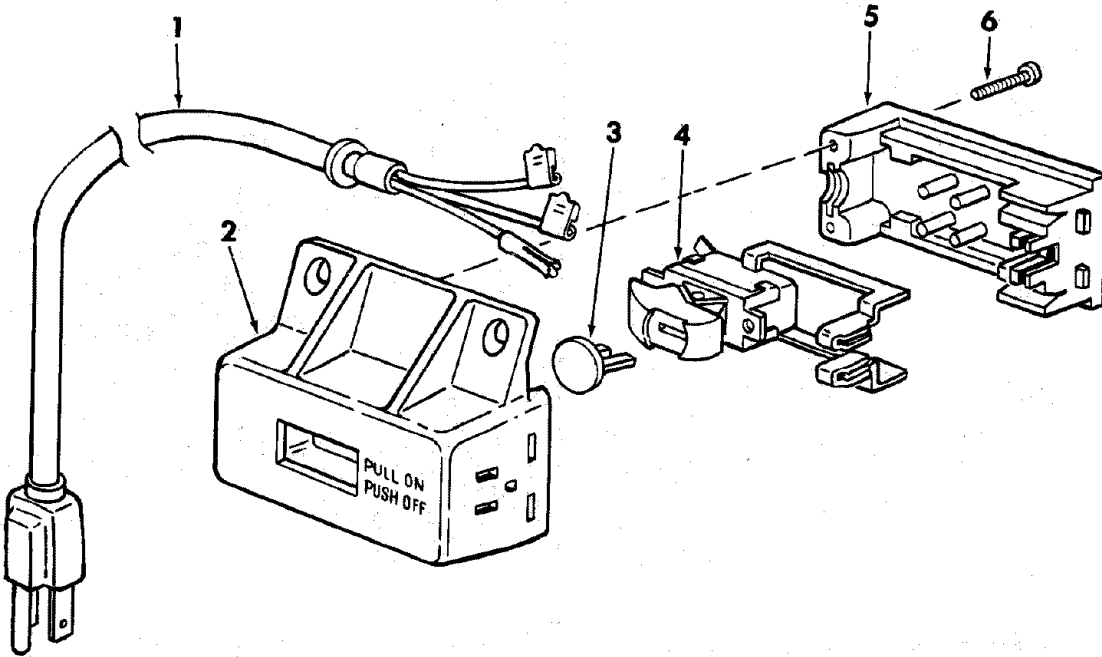
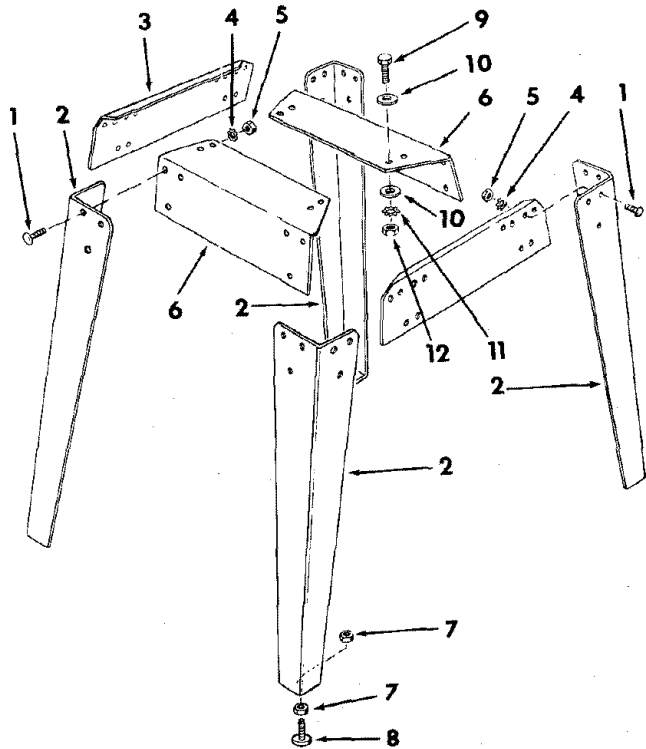

FIGURE 6 – ON/OFF POWER OUTLET 60381

| Key No. | Part No. | Description |
|---------|----------|--------------------------------|
| — | 60381 | • On/Off Power Outlet Complete |
| 1 | 60375 | Cord, Molded |
| 2 | 60380 | Housing, Switch |
| 3 | 60256 | Key, Switch |
| 4 | 60374 | Switch, Locking |
| 5 | 60377 | Cover, Switch |
| 6 | 448007 | Screw, pn Hd. No. 6 x 3/4 |

• Does Not Include Key No. 3
Order Separately If Required.

**PARTS LIST FOR CRAFTSMAN 10 INCH TABLE SAW
MODEL NO. 113.298142, 113.298032 & 113.298240**



**FIGURE 7 -- LEGS SUPPLIED WITH
113.298032 AND 113.298240 ONLY**

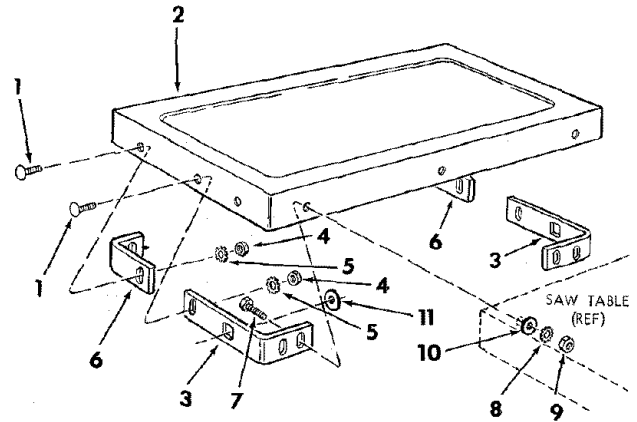

**FIGURE 8 -- TABLE EXTENSION SUPPLIED
WITH MODEL 113.298032 AND 113.298240**

| Key No. | Part No. | Description |
|--|------------|---|
| 1 | 60314 | Screw, Serrated Truss Hd. 1/4-20 x 5/8 |
| 2 | 62552 | Leg |
| 3 | 62554 | Stiffener, Side |
| 4 | STD 551225 | *Lockwasher, Ext. 1/4 |
| 5 | STD 541025 | *Nut, Hex 1/4-20 |
| 6 | 62553 | Stiffener, End |
| 7 | STD 541250 | *Nut, Hex 1/2-13 |
| 8 | 803835 | Foot, Leveling |
| HARDWARE FOR ATTACHING LEGS TO SAW. | | |
| 9 | STD 523112 | *Screw, Hex Hd. 5/16-18 x 1-1/4 |
| 10 | STD 551031 | Washer, 11/32 I.D. |
| 11 | STD 551131 | *Lockwasher, Ext. 5/16 |
| 12 | STD 541031 | *Nut, Hex 5/16-18 |
| | 62752 | Bag of Loose Parts For Legs (not illust.) |

| Key No. | Part No. | Description |
|---------|------------|--|
| — | 62589 | †Extension Assembly, Complete |
| 1 | 60323 | Screw, Serrated Truss Hd., 1/4-20 x 1" |
| 2 | 62590 | Extension |
| 3 | 62549 | Bracket, Corner Support |
| 4 | STD 541025 | *Nut, Hex 1/4-20 |
| 5 | STD 551225 | *Lockwasher, Ext. 1/4 |
| 6 | 62550 | Bracket, Corner Stiffener |
| 7 | STD 523112 | *Screw, Hex Hd. 5/16-18 x 1-1/4 |
| 8 | STD 551131 | *Lockwasher, Ext. 5/16 |
| 9 | STD 541031 | *Nut, Hex 5/6-18 |
| | 62745 | Bag of Loose Parts (not illustrated) |
| 10 | STD 551031 | *Flat Washer, 11/32 I.D. |
| 11 | STD 551025 | *Flat Washer, 17/64 I.D. |

* Standard Hardware Items — May be Purchased Locally.

• Bag contains all Loose Parts for Extensions.

† Stock Item — May be secured through the Hardware Department of most Sears retail stores or catalog order house.

Sears

*owners
manual*

SERVICE

MODEL NO.

113.298142

SAW ONLY

113.298032

SAW WITH LEGS
TWO TABLE EXTENSIONS
AND MOTOR

113.298240

SAW WITH LEGS
TWO TABLE EXTENSIONS
MOTOR AND HOLD DOWN

**HOW TO ORDER
REPAIR PARTS**

10 INCH TABLE SAW

Now that you have purchased your 10-inch table saw should a need ever exist for repair parts or service, simply contact any Sears Service Center and most Sears, Roebuck and Co. stores. Be sure to provide all pertinent facts when you call or visit.

The model number of your 10-inch table saw will be found on a plate attached to your saw, at the left-hand side of the base.

WHEN ORDERING REPAIR PARTS, ALWAYS GIVE THE FOLLOWING INFORMATION:

| PART NUMBER | PART DESCRIPTION |
|---|-----------------------------------|
| MODEL NUMBER 113.298142, 113.298032 or 113.298240 | NAME OF ITEM 10-INCH TABLE SAW |

All parts listed may be ordered from any Sears Service Center and most Sears stores. If the parts you need are not stocked locally, your order will be electronically transmitted to a Sears Repair Parts Distribution Center for handling.

Sold by SEARS, ROEBUCK AND CO., Chicago, IL. 60684 U.S.A.