



***84" Integrated Side-by-Side
Refrigerator***

Owner's Guide

Contents

Electrical Requirements	2
Model Identification	2
Model Diagram	3
Controls	4
Posi-Temp™ System	4
Showroom Switch	4
Power Switch	4
Touchmatic™ Electronic Controls	4
Setting Controls	5
Refrigerator Features	5
Water Filtration System	5
Spillsaver™ Shelves	5
Chill Zone	6
Humidity Controlled Crispers	6
Chef's Pantry™	6
Covered Storage Bucket	7
Dairy Centers	7
Wine Trivet	7
Door Shelves	7
Adjustable Dividers	7
Freezer Features	8
Automatic Ice Maker	8
Ice 'N' Water™ Dispenser (Some models)	8
Water Dispenser Operation	8
Ice Dispenser Operation	8
Removing Ice Bucket (Ice n' Water units only)	9
Dispenser Light (Dispenser units only)	9
Water Quality	9
Care and Cleaning	10
General	10
Odor Removal	10
Adhesives	10
Door Gaskets	10
Glass Shelves	10
Door Stop Adjustment	11
Light Bulbs	11
Drain Pan	12
Energy Tips	12
Vacation Tips	12
Normal Operating Sounds	12
Before Calling For Service	13
Factory Service Centers	14

Keep these instructions for future reference. Be sure this manual stays with refrigerator.

Electrical Requirements

 **Recognize this symbol as a safety precaution.**

 **WARNING**

Electrical Grounding Instructions —This refrigerator is equipped with a three-prong (grounding) plug for protection against possible shock hazards. If a two-prong wall receptacle is encountered, contact a qualified electrician and have the two-prong wall receptacle replaced with a properly grounded three-prong wall receptacle in accordance with the National Electrical Code.

Refrigerator is designed to operate on a separate 103 to 126 volt, 15 amp., 60 cycle line.

Do not under any circumstances cut or remove the round grounding prong from the plug. Refrigerator must be grounded at all times. Do not remove warning tag from power cord.

Do not use a two-prong adapter. Do not use an extension cord.

Model Identification

Thank you for purchasing this refrigerator. Please read this Owner's Manual thoroughly. This manual provides proper maintenance information. Any questions, call the Consumer Affairs Department at **1-800-843-0304** inside U.S.A. and **1-319-622-5511** outside U.S.A.

Complete registration card and promptly return. If registration card is missing, call the Consumer Affairs Department.

When contacting Amana Appliances, provide product information. Product information is on the serial plate, located on the lower right side of refrigerator cabinet hidden by Chef's Pantry. Record the following information:

Model Number: _____

Manufacturing Number: _____

S/N or Serial Number: _____

Date of purchase: _____

Dealer's name and address: _____

Service

Keep a copy of sales receipt for future reference or in case warranty service is required. Any questions or to locate an authorized servicer, call 1-800-NAT-LSVC (1-800-628-5782) inside U.S.A. 319-622-5511 outside U.S.A. Warranty service must be performed by an authorized servicer. Amana Appliances, also recommends contacting an authorized servicer if service is required after warranty expires.

Asure™ Extended Service Plan

Amana Appliances offers long-term service protection for this new refrigerator. Asure™ Extended Service Plan is specially designed to supplement Amana Appliances strong warranty. This plan covers parts, labor, and travel charges. Call 1-800-528-2682 for information.

DANGER

Proper Disposal of Your Refrigerator

IMPORTANT: Child entrapment and suffocation are not problems of the past. Junked or abandoned refrigerators are still dangerous-- even if they will sit for "just a few days." If you discard an old refrigerator, please follow the instructions below to help prevent accidents.

BEFORE YOU THROW AWAY YOUR OLD REFRIGERATOR OR FREEZER:

- Take off the doors.
- Leave the shelves in place so that children may not easily climb inside.

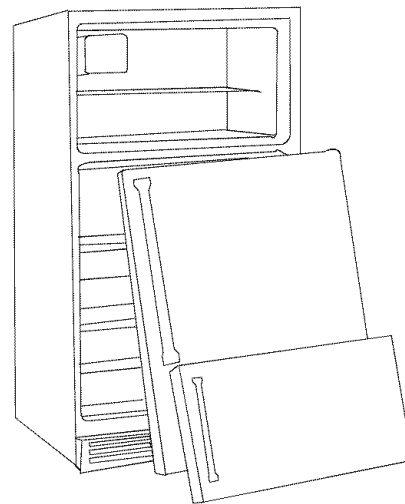

Model Diagram

1. Touchmatic™ Electronic Control
2. Dairy Center
3. 3 piece storage bucket
4. Adjustable door shelves
5. Adjustable divider
6. Chef's Pantry™
7. Humidity controlled crispers
8. Ice storage bucket (non dispensing units only)
9. Freezer non-adjusting interior shelves
10. Deli Center
11. Spillsaver™ shelves
12. Wine Trivet
13. Adjustable freezer shelves
14. Removable freezer door buckets
15. Glide-out freezer baskets
16. Ice dispensing/storage bucket (dispensing units only)
17. Lights

Models without ice and water dispenser

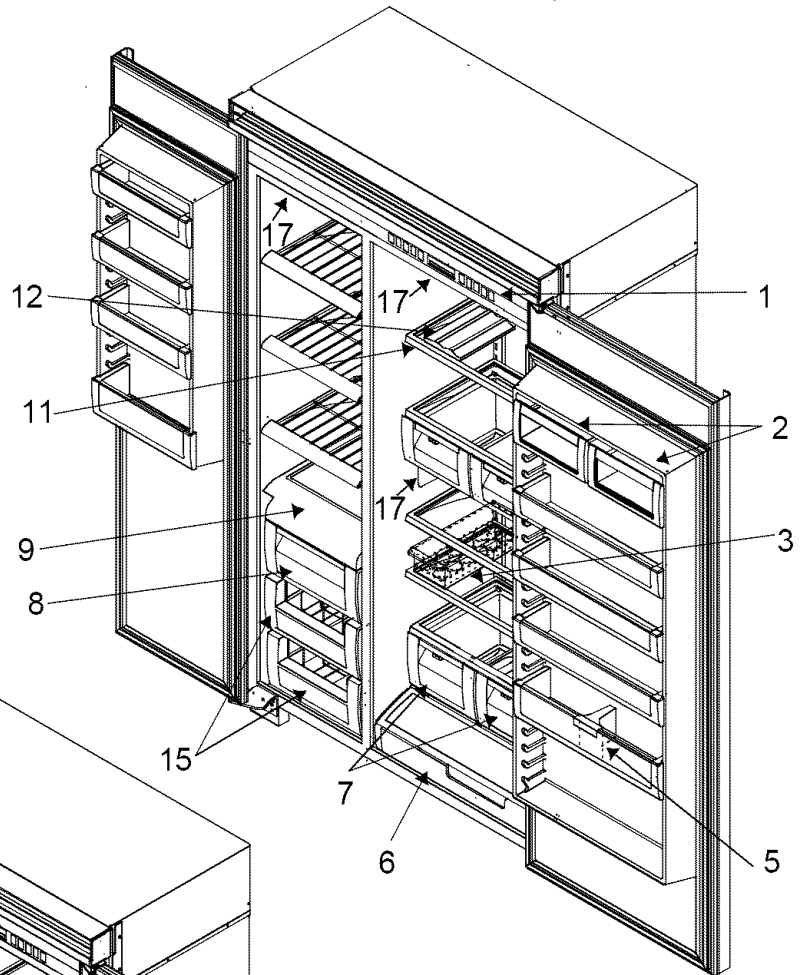

Models with ice and water dispenser

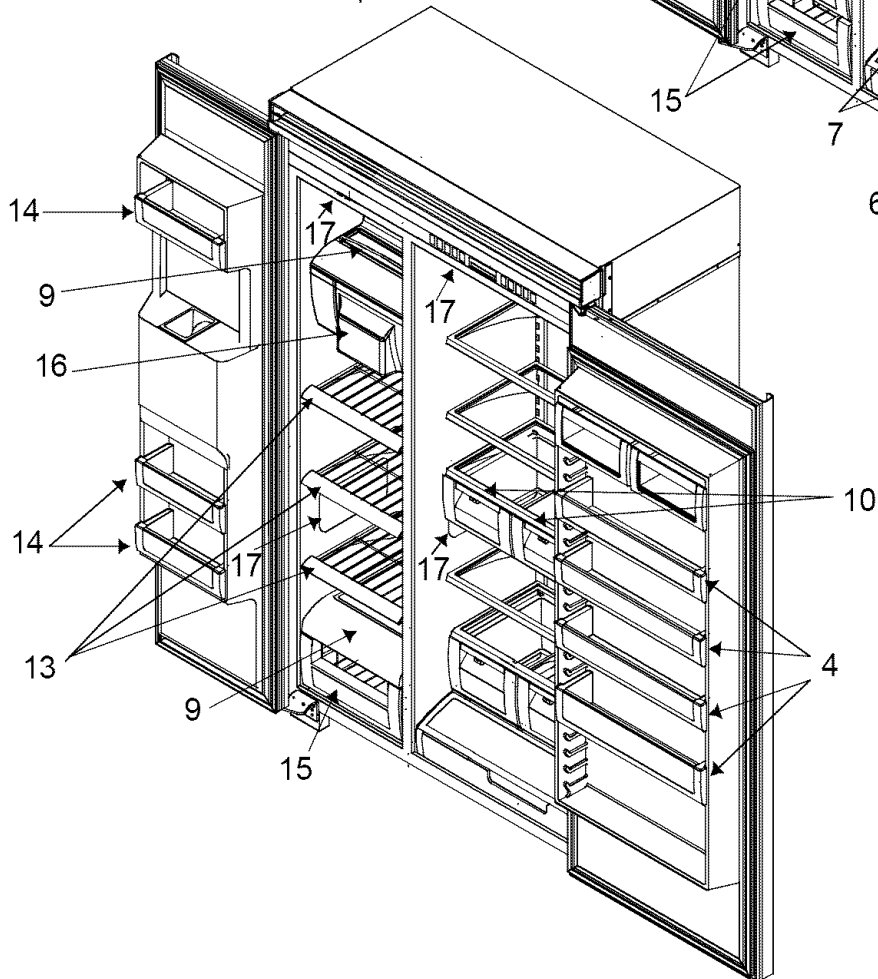

Controls

This refrigerator operates most efficiently in normal household temperatures of 65° to 90°F (18° to 32°C).

Posi-Temp™ System

Posi-Temp™ system automatically maintains selected temperatures in both refrigerator and freezer sections. Refrigerator thermistor controls fresh food fan operation while a separate freezer thermistor controls compressor and freezer fan operation. These thermistors allow foods to cool or freeze quickly and provide even temperatures throughout refrigerator and freezer sections.

Showroom Switch

Showroom switch allows electronic controls and interior lights to function independently of refrigeration system. Showroom switch is located behind air grille to right of control panel. Refrigerator is shipped with showroom switch in unit *off* position.

Power Switch

Use power switch to disconnect power without unplugging refrigerator. Power switch is located behind air grille on top right side. Refrigerator is shipped with power switch in *on* position.

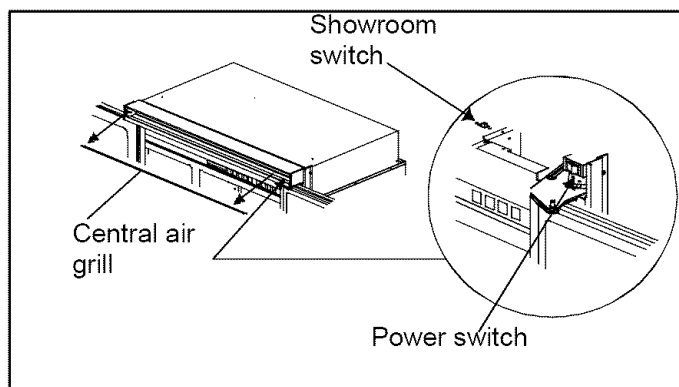

Switch may be accessed by removing center grille louver.

Touchmatic™ Electronic Controls

Touchmatic™ electronic controls are located behind the refrigerator door above the refrigerator section. Press *Display On* pad to activate control panel. All pads except *Alarm Off* pad remain inactive until *Display On* pad is pressed. Once activated, pads remain programmable for at least 10 minutes.

Entry Tone

Entry tone indicates a pad was pressed and command was read and accepted.

- Deactivate entry tone by pressing and holding *Display On* pad for 3 to 5 seconds. Three short beeps indicate instructions were accepted.
- Activate entry tone by pressing and holding *Display On* pad for 3 to 5 seconds.

Refrigerator and freezer controls are preset at 5. Wait 24 hours after connecting power for refrigerator and freezer sections to reach desired temperatures. After 24 hours, adjust controls as desired. 1 is warmest setting and 9 is coldest. Refer to "Setting Controls" section to set controls precisely.

- Adjust refrigerator or freezer temperature by pressing *Display On* pad then *Ref Temp* pad or *Freezer Temp* pad. Press *Warmer* pad or *Colder* pad to adjust temperature setting 1 level at a time. Holding down *Warmer* pad or *Colder* pad adjusts temperature more than 1 level at a time.

Max Refrigerator Mode

Max refrigerator mode adjusts refrigerator temperature to coldest setting. After 10 hours, refrigerator temperature automatically returns to previous setting.

- Activate max refrigerator mode by pressing *Display On* pad then *Max Ref* pad. Indicator light will glow.
- Deactivate max refrigerator mode before automatic reset by pressing *Display On* pad then *Max Ref* pad.

Max Freezer Mode

Max freezer mode adjusts freezer temperature to coldest setting. After 24 hours, freezer temperature automatically returns to previous setting.

- Activate max freezer mode by pressing *Display On* pad then *Max Frz* pad. Indicator light will glow.
- Deactivate max freezer mode before automatic reset by pressing *Display On* pad then *Max Frz* pad.

Refrigerator Features

Door Open Alarm

Door open alarm sounds and indicator light blinks if either door is open for more than 3 minutes.

- Deactivate door open alarm by pressing *Alarm Off* pad or by closing either door.
- Activate door open alarm by pressing *Display On* pad then holding *Alarm Off* pad for 3 to 5 seconds. Three short beeps indicate instructions were accepted.

High Temperature Alarm

High temperature alarm sounds and indicator light glows if refrigerator or freezer temperature is high for 2 hours. A blinking light signals affected compartment. Alarm ends when proper temperature is reached.

- Deactivate high temperature alarm by pressing *Alarm Off* pad.

Thermistor Alarm

Thermistor electronically senses refrigerator and freezer temperatures. Thermistor alarm sounds and indicator lights scroll if refrigerator or freezer thermistor is not operating properly.

- Deactivate display by pressing *Alarm Off* pad.

If thermistor alarm sounds, contact an authorized Amana technician immediately. If *Alarm Off* pad is pressed, thermistor control retests to confirm situation has been corrected. Alarm sounds again if thermistor is still not operating properly. Alarm can be reset by turning power disconnect switch to off position and turning back to on position.

Display Lights

- Deactivate temperature display lights by pressing *Display On* pad then pressing *Display Off* pad.
- Activate temperature display lights by pressing *Display On* pad.

Setting Controls

Set controls precisely with a household thermometer that includes temperatures between -5° to 50°F (-21° to 10°C).

Put thermometer snugly between frozen packages in freezer section. Wait 5-8 hours. If freezer temperature is not 0° to 2°F (-17° to -16°C), adjust control, 1 number at a time. Check again after 5-8 hours.

Put thermometer in a glass of water in middle of refrigerator section. Wait 5-8 hours. If refrigerator temperature is not 38° to 40°F (3° to 4°C), adjust control, 1 number at a time. Check again after 5-8 hours.

Water Filtration System

The Amana® Clean 'n Clear™ water filtration system provides water treatment with a revolutionary 2-stage design. Refer to Clean 'n Clear™ water filtration system installation and operating instructions.

Spillsaver™ Shelves



CAUTION

To avoid personal injury and property damage, confirm shelf is secure before placing items on shelf.

Spillsaver™ shelves are constructed of polypropylene molded around the glass and metal rail. Therefore, Spillsaver™ shelves are completely encapsulated and liquids cannot seep under the glass. This localizes spills and provides easier cleaning. Spillsaver™ shelves also adjust to meet individual storage needs.



CAUTION

To avoid personal injury or property damage, handle tempered glass shelves carefully. Shelves may break suddenly if nicked, scratched, or exposed to sudden temperature change.

- Remove shelves by lifting front, releasing hooks from metal track then pulling out.
- Replace shelves by inserting hooks into metal track and lowering front.

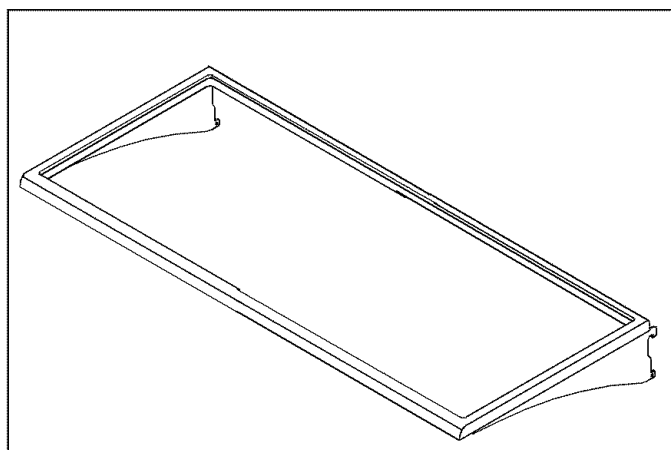

Chill Zone

Chill Zone features 2 humidity controlled crispers and the Chef's Pantry™. Freezer air circulating in the Chill Zone is contained by gaskets in the shelf above the crispers. Chill Zone keeps food up to 3 - 5°F colder than refrigerator temperature.

Chill Zone control is located to the right of the Chef's Pantry™ underneath the Chef's Pantry™ lid. The control adjusts the amount of freezer air circulating in this area. Slide control down for normal refrigerator temperature and up for colder temperature.

Humidity Controlled Crispers

Sealed drawers allow deli and produce items to stay fresh longer. Crisper controls allow you to adjust the humidity levels within the crispers.

The following will also help produce to stay fresh longer.

- Wrap produce tightly.
- Do not wash produce before placing in crispers. Excess moisture could cause produce to spoil prematurely.
- Do not line drawers with paper towels. Paper towels will retain moisture.

Crisper controls are located underneath front trim. Control adjusts crisper humidity. Slide control right for deli items and produce with leaves such as lettuce, spinach, or cabbage. Slide control left for produce with skins such as cauliflower, corn, or tomatoes.

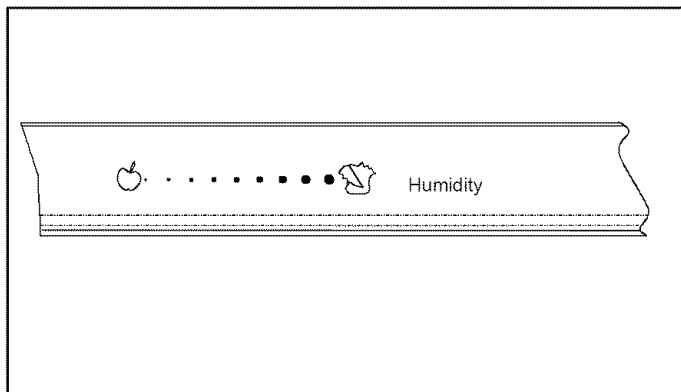

Humidity controlled crispers can temporarily be adjusted to meet storage needs of the Chef's Pantry.

- Remove drawers by lifting and pulling out. Remove shelf by lifting front, releasing hooks from metal track then pulling out.
- Replace shelf by inserting hooks into metal track and lowering front. Replace drawers by sliding in.

- Remove one crisper with 90° door opening, center glide support will slide out for removal of second crisper.

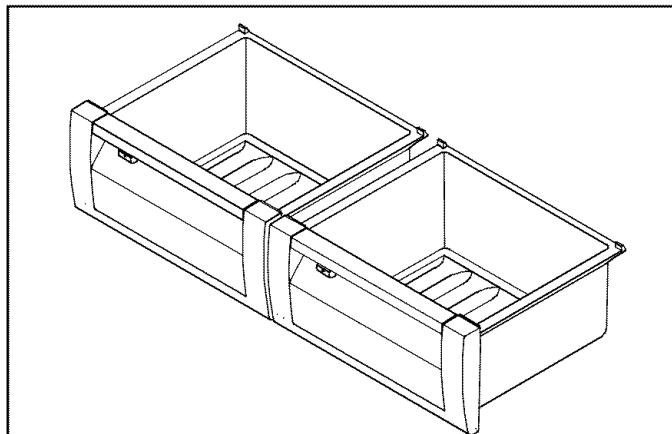

Chef's Pantry™

As the drawer glides forward on an inner and outer track, the lid raises for easy access of items. Chef's Pantry™ holds extra-large deli trays, wine bottles, etc. The lid can also be removed and the crispers repositioned for tall items such as tiered cakes, flower arrangements, etc.

1. Raise humidity controlled crispers. **Chef's Pantry™ cover is not designed for use as shelf when crispers are raised.**
2. Remove lid by lifting back to release hooks then pulling out.
3. Replace lid by inserting hooks into drawer then placing back and front down.
4. Return crispers to original position.

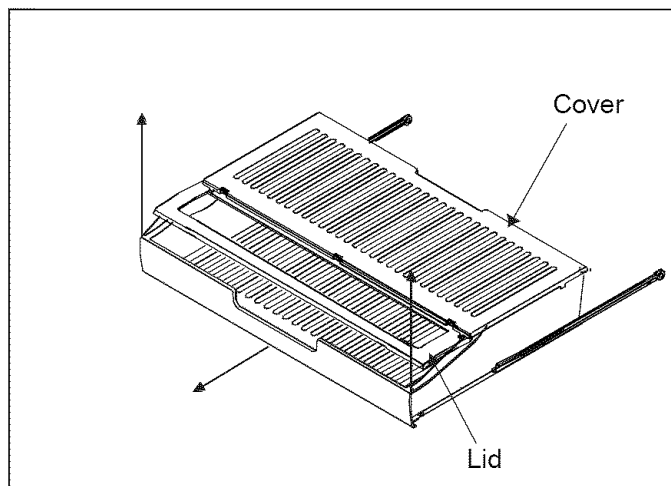

Covered Storage Bucket

Storage bucket has a lid and removable egg tray. When tray is removed, bucket will accept items such as a standard egg carton, ice, etc.

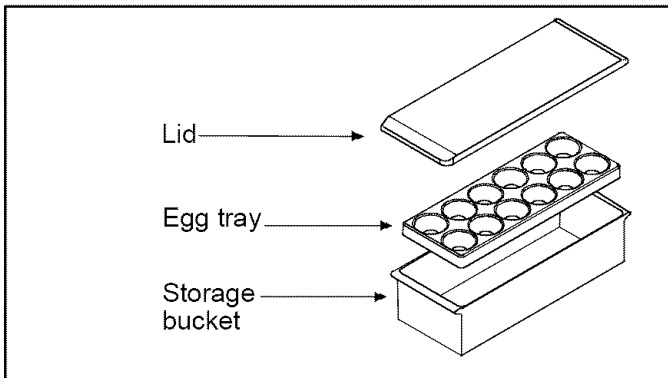

Door Shelves

- Remove door shelves by lifting and pulling out.
- Replace door shelves by placing shelf over glide and sliding down.

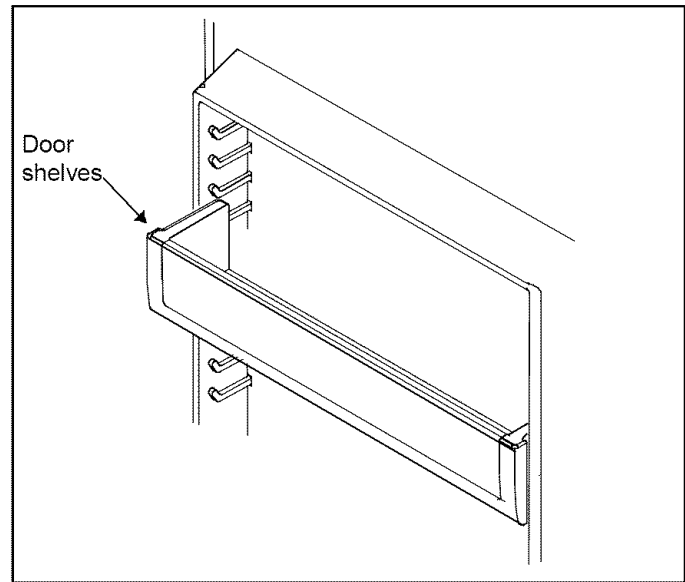

Dairy Centers

Dairy center doors are surrounded by gaskets for a tighter seal which allows items to stay fresh longer. Dairy centers also adjust to meet individual storage needs.

- Remove dairy center by lifting and pulling out.
- Replace dairy center by placing shelf over glide and sliding down.

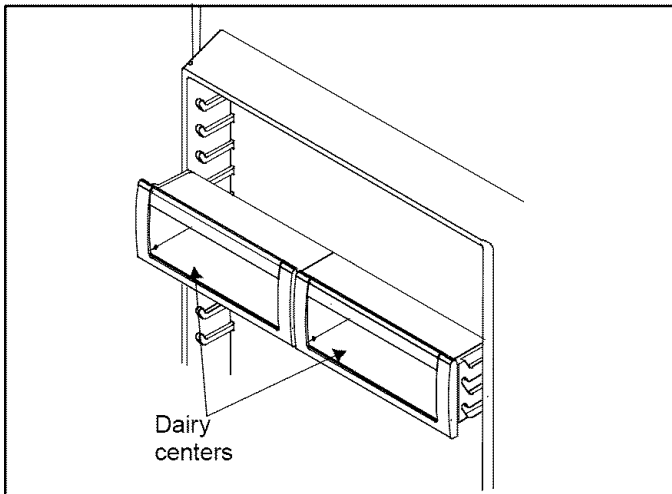

Adjustable Dividers

Adjustable dividers keep items in place and adjust to meet individual storage needs. Dividers fit in any door shelf.

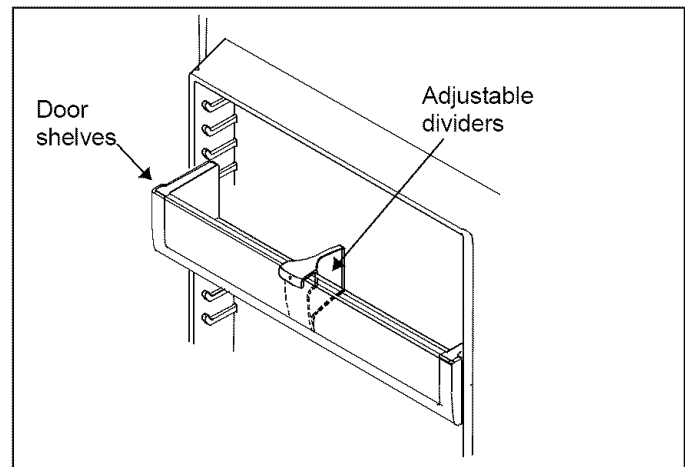

Wine Trivet

Used for horizontal bottle storage on refrigerator shelves. Wine trivets can be interlocked to pyramid up to six bottles.

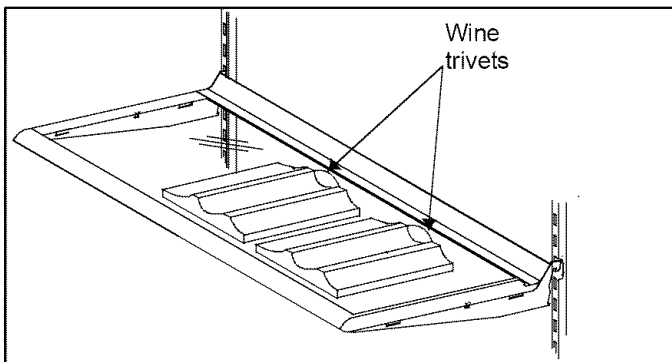

Freezer Features

CAUTION

To avoid personal injury or property damage, confirm shelf is secure before placing items on shelf.

Automatic Ice Maker

Ice maker and slide-out ice bin (non-dispensing models only) are not adjustable. Ice bin slides forward for easy access of ice. Ice maker will not produce ice when ice bin is pulled out.

- After freezer section reaches normal temperature, ice maker fills with water and begins operating. Allow 24-48 hours after installation before first harvest of ice. Ice maker produces 7 to 9 harvests of ice in a 24-hour period under ideal conditions.
- After ice is formed, ice maker drops ice cubes into ice bin. During ice production, ice maker arm raises and lowers. When ice bin is full, ice maker arm turns ice maker off. Discard first 3 harvests of ice after initially connecting refrigerator to household water supply and after extended periods of non-use.
- Stop ice production by raising ice maker arm. A definite click is heard when proper position is reached.
- In nondispensing models ice maker will not function unless ice bin is pushed all the way back into position.

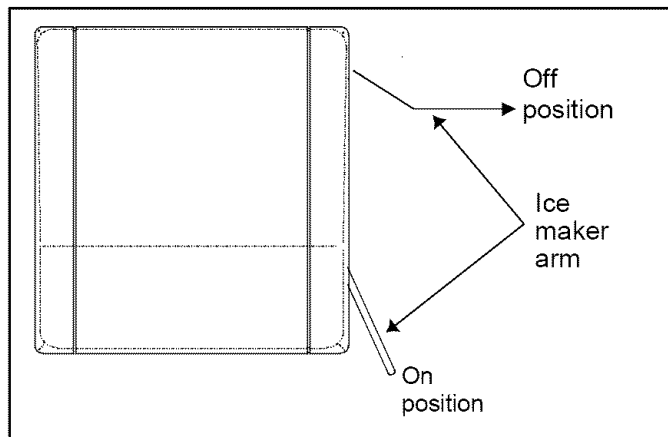

CAUTION

To avoid damage to ice maker, observe the following:

- Do not force ice maker arm down or up, past stop position.
- Do not place or store anything in ice bucket.

Ice 'N' Water™ Dispenser (Some models)

CAUTION

To avoid personal injury or property damage, observe following instructions:

- Do not operate dispenser with freezer door open.
- Do not put fingers, hands, or any foreign object into dispenser opening.
- Do not use sharp objects to break ice.

Water Dispenser Operation

It takes approximately 1 minute after initially connecting refrigerator to household water supply before water dispenses. Discard first 10 to 14 containers of water after initially connecting refrigerator to household water supply and after extended periods of non-use.

- Dispense water by pressing sturdy wide-mouthed container against water dispenser pad.
- Stop water dispensing by releasing pressure on pad. A small amount of water may continue to fall. Spill shelf is not self-draining. Large spills should be wiped dry.

Ice Dispenser Operation

CAUTION

To avoid property damage, do not dispense ice directly into thin glass, fine china, or delicate crystal.

- Select cubed or crushed mode by sliding lever on dispenser panel. Dispense ice by pressing wide mouthed container against ice dispenser pad.
- Stop ice dispensing by releasing pressure on pad before container is full. Some ice will continue to fall. Do not remove container until last of ice falls.

Important

Reduce spraying of crushed ice by holding wide mouthed container directly under ice chute and as high as possible in dispenser area.

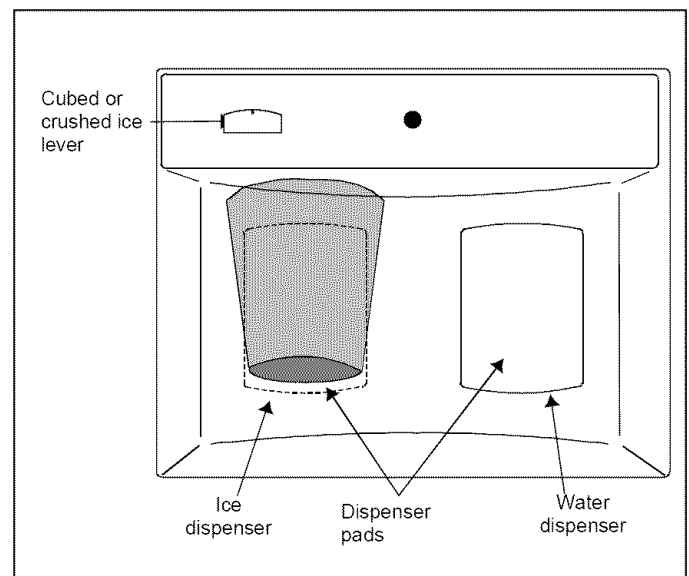

If dispensing ice continuously, dispenser motor is designed to shut off after 3 to 5 minutes. Motor resets after 3 minutes and dispensing can continue.

A slight delay occurs when switching between cubed and crushed modes. Pieces of crushed ice will vary in size and shape. "Snow" may form on door and ice chute when repeatedly dispensing crushed ice. Allow "snow" to evaporate or wipe dry.

Dispenser operates only with cubes of proper size and crescent shape. Do not add purchased ice cubes or other shaped cubes to ice bucket.

Removing Ice Bucket (Ice n' Water units only)

- Remove ice bucket by lifting bucket and pulling out.
- Replace ice bucket by sliding in until bucket locks in place. Ice bucket must be locked in place for proper ice dispensing. If Deepfreeze® door does not close, bucket is not in proper location.

Dispenser Light (Dispenser units only)

A light is activated when dispensing ice or water. Some models feature a night light which comes on automatically when room is darkened.

- Deactivate night light by pushing rocker switch, located underneath dispenser and right of water dispenser bar.

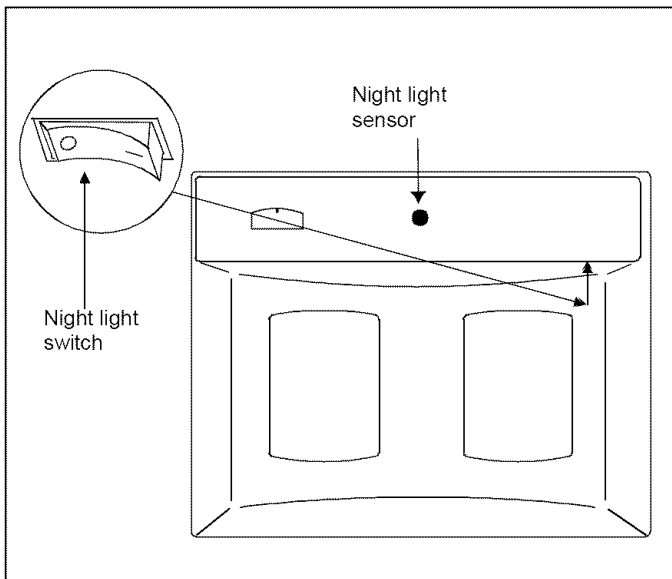

Water Quality

Observe the following to minimize taste and odor difficulties:

- Install water filter, WF60, on water line (shipped with refrigerator).
- Contact local water treatment company for specialized help if difficulties persist.

Care and Cleaning

WARNING

To avoid electrical shock which can cause severe personal injury or death, turn power switch to *off* position before cleaning. After cleaning, return power switch to *on* position.

CAUTION

To avoid personal injury or property damage, read and follow all cleaning product manufacturer's directions.

General

1. Wash surfaces with 4 tablespoons baking soda dissolved in 1 quart warm water and a soft, clean cloth.
 2. Rinse surfaces with warm water. Dry surfaces with a soft, clean cloth.
- Do not use the following items:
 - abrasive or harsh cleaners, ammonia, chlorine bleach, etc.
 - concentrated detergents or solvents
 - metal scouring padsThese items can scratch, crack and discolor surfaces.
 - Do not place buckets, shelves, etc. in dishwasher.

Odor Removal

1. Remove all food and turn power disconnect switch to *off* position.
2. Clean all interior surfaces including ceiling, floor, and walls according to "General" instructions. Pay special attention to corners, crevices, and grooves. Include all drawers, shelves, and gaskets.
3. Turn power disconnect switch to *on* position and return food to refrigerator. Wash and dry all bottles, containers and jars. Foods should not be stored uncovered in your refrigerator. Wrap food or place food in a sealed container. Sealing food retains moisture and flavor while preventing odor transfer to other food items. After 24 hours, check if odor was eliminated.

Complete the following steps if odor was not eliminated.

4. Complete steps 1-2.
5. Place humidity controlled crispers on top shelf of refrigerator section. Pack refrigerator and freezer sections including doors with crumpled sheets of black and white newspaper.
6. Place charcoal briquettes randomly throughout newspaper.
7. Close doors and let stand 24-48 hours.
8. Remove charcoal briquettes and newspapers.
9. Complete steps 2-3.

Contact Consumer Affairs Department if odor was still not eliminated. (1/800-843-0304)

Adhesives

1. Remove glue residue by rubbing toothpaste into adhesive with fingers until adhesive loosens.
2. Rinse surface with warm water. Dry surface with a soft, clean cloth.

Door Gaskets

1. Clean door gaskets every 3 months according to "General" instructions.
2. Apply a light film of petroleum jelly to keep gaskets pliable.

Glass Shelves

CAUTION

To avoid personal injury or property damage, handle tempered glass shelves carefully. Shelves may break suddenly if nicked, scratched, or exposed to sudden temperature change.

Remove shelf by lifting front, releasing hooks from metal track then pulling out. Place shelf on a towel. Allow shelf to adjust to room temperature before cleaning.

Clean crevices by completing the following steps:

1. Dilute mild detergent and brush solution into crevices using a plastic bristle brush. Let set for 5 minutes.
2. Spray warm water into crevices using faucet spray attachment.
3. Dry shelf thoroughly and replace shelf by inserting hooks into metal track and lowering front.

Door Stop Adjustment

WARNING

To avoid electrical shock which can cause severe personal injury or death, turn power switch to *off* position before replacing light bulb or adjusting door stop. After replacing light bulb, return power switch to *on* position.

1. Remove center grille blade from top air grille.
2. Remove top air grille by removing (4) ¼" screws with a magnetic screw driver. Pull assembly forward.
3. Open refrigerator door so door stop arm and shoulder screw are accessible. Shoulder screws should be in 110° door opening position.

4. Remove shoulder screw and place shoulder screw in the 90° or 120° door opening position.
5. Replace air grille assembly.

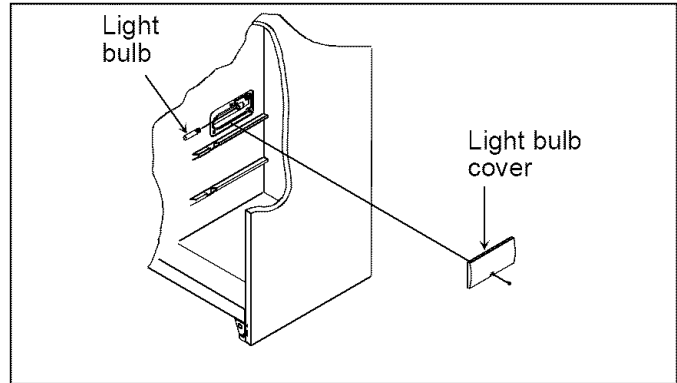
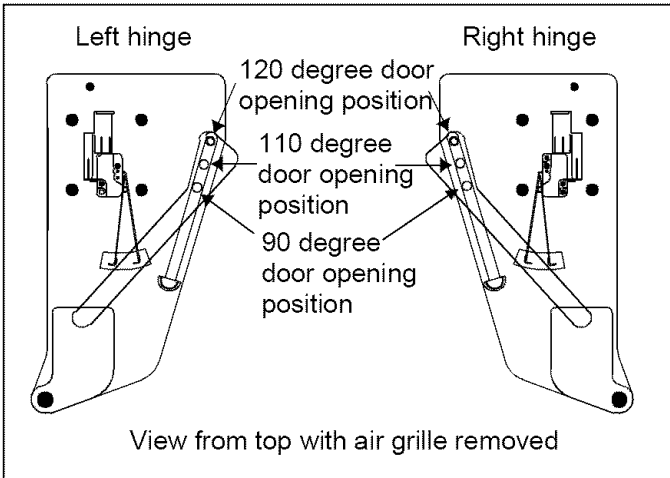

- Remove bulb by turning bulb counterclockwise. Replace bulb with 40 watt bayonet style appliance bulb.
- Lower freezer compartment bulb (dispensing models) is removed by removing 1/4" hex head screw from top of cover. Pull cover bottom tab out of bottom slot.

Light Bulbs

CAUTION

To avoid personal injury or property damage, observe the following:

- Allow light bulb to cool.
- Wear gloves when replacing light bulb.

Upper Light bulbs

- Remove cover by removing screws. Cover drops down. Replace with maximum 40 watt light bulbs.

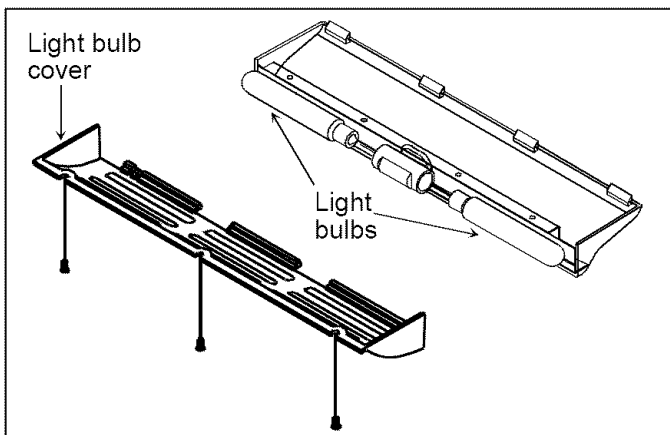

- Replace cover by holding cover against ceiling. Insert and tighten screws.

Lower light bulbs

- Lower refrigerator compartment (and freezer compartment in non dispensing units) bulb is removed by removing 1/4" hex head screw from bottom of cover. Tilt cover up and pull out.

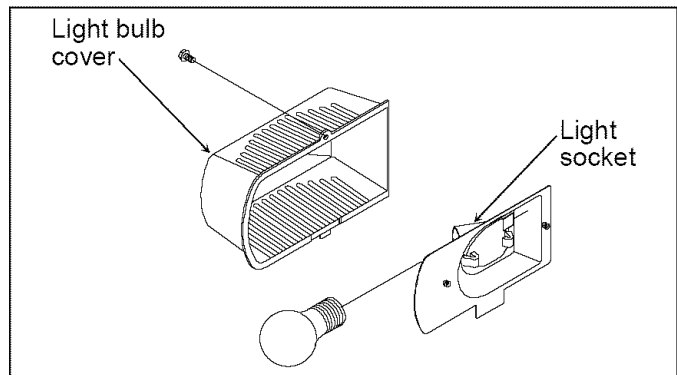

- Remove bulb by turning counterclockwise. Replace bulb with 40 watt appliance bulb.

Drain Pan

Prevent condensation from overflowing by checking drain pan periodically. To remove drain pan, remove 2 screws in toe grille. Pull drain pan forward. Empty any condensation and replace drain pan and toe grille.

Energy Tips

Reduce energy use by observing the following.

- Operate in normal household temperatures of 65° to 90°F (18° to 32°C) away from heat sources and direct sunlight.
- Set refrigerator, freezer, and Chill Zone controls no colder than necessary.
- Keep freezer section full.
- Keep door gaskets clean and pliable. Replace gaskets if worn.

Vacation Tips

Complete the following steps for short vacations.

1. Remove perishable foods. **Warranty does not cover food loss.** Check warranty certificate for specific coverage.
2. Move ice maker arm to *off* position.

Complete the following steps for long vacations.

1. Empty refrigerator and freezer sections.
2. Turn power switch to *off* position.
3. Clean refrigerator and door gaskets according to "General" instructions in "Care and Cleaning" section.
4. Prop doors open, so air can circulate inside.
5. Turn water supply to refrigerator *off*.

Normal Operating Sounds

This new refrigerator may be replacing a differently designed, less efficient or smaller refrigerator. Today's refrigerators have new features and are more energy efficient. As a result, certain sounds may be unfamiliar. These sounds are normal and will soon become familiar. These sounds also indicate refrigerator is operating and performing as designed.

- **Freezer and fresh food fan** air rushes and whirs.
- **Sealed system** (evaporator and heat exchanger) refrigerant flow gurgles, pops or sounds like boiling water.
- **Defrost heater** sizzles, hisses or pops.
- **Condenser fan** air rushes and whirs.
- **Compressor** has a high pitched hum or pulsating sound.
- **Ice cubes** from ice maker drop into ice bucket.
- **Ice maker water valve hookup** buzzes when ice maker fills with water. This occurs whether or not refrigerator is connected to water supply. If refrigerator is not connected to water supply, stop sound by raising ice maker arm to *off* position.
- Foam insulation is very energy efficient and has excellent insulating capabilities. However, foam insulation is not as sound absorbent as previously used fiberglass insulation.

Before Calling For Service

Refrigerator does not operate.

- Confirm showroom switch is in *run* position.
- Confirm power switch is *on*.
- Check fuse or circuit breaker.
- Wait 40 minutes to see if refrigerator restarts. If lights work but fans and compressor are not operating, refrigerator may be in defrost cycle.

Refrigerator still won't operate.

- Turn *off* power switch. Transfer food to another unit or place dry ice in freezer section to preserve food. **Warranty does not cover food loss.** Check warranty certificate for specific coverage.
- Call **1-800-628-5782** inside U.S.A. and **1-319-622-5511** outside U.S.A. to locate an **authorized** Amana technician.

Food temperature appears too warm.

- See above sections.
- Allow time for recently added warm food to reach refrigerator or freezer temperature.
- Check gaskets for proper seal.
- Adjust refrigerator and/or freezer setting.

Chill Zone temperature is too warm.

- Slide control to colder setting.
- Adjust freezer control to colder setting.

Food temperature is too cold.

- Adjust refrigerator control.
- Adjust freezer to warmer setting. Allow several hours for temperature to adjust.

Refrigerator runs too frequently.

- It may be normal to maintain constant temperature.
- Doors may have been opened frequently or for an extended period of time.
- Allow time for recently added warm food to reach refrigerator or freezer temperature.
- Adjust freezer setting.
- Check gaskets for proper seal.

Water droplets form on inside of refrigerator.

- It is normal during high humidity periods or if doors have been opened frequently.

Water droplets form on outside of refrigerator.

- Check door gaskets for proper seal.

Crispers or Chef's Pantry™ does not close freely.

- Check for a package which may prevent drawer from closing properly.
- Confirm drawer is in proper position.
- Clean drawer channels with warm, soapy water. Rinse and dry thoroughly.
- Apply a thin layer of petroleum jelly to drawer channels.
- Confirm refrigerator is level.

Refrigerator has an odor.

- See "Odor Removal" instructions in "Care and Cleaning" section.

Refrigerator or ice maker make unfamiliar sounds or seems too loud.

- It may be normal. See "Normal Operating Sounds" section.

Ice maker is not producing ice.

- Confirm ice maker arm is down.
- Confirm household water supply is reaching water valve.
- Confirm ice maker wiring harness is completely inserted into proper holes.
- Check for kinks in tubing. Remove kinks or replace tubing.
- Check electrical connections to water valve coil.
- Confirm freezer section is operating at proper temperature.
- Water filter cartridge may need to be replaced.

Ice cubes have an odor.

- See "Odor Removal" instructions in "Care and Cleaning" section.
- Discard ice and clean ice bucket more frequently. Ice cubes are porous and absorb odors from other items stored in freezer.
- Water filter cartridge may need replaced.

Ice cubes stick together or "shrink".

- Empty ice bucket more frequently. If used infrequently, ice cubes may stick together or shrink.

Ice forms in inlet tube to ice maker.

- Check water pressure. Low water pressure will cause valve to leak. Self-piercing valves cause low water pressure. **Amana recommends using a saddle valve. Contact 1-800-843-0304 or an Amana dealer for availability. Do not use self-piercing valve. Amana is not responsible for property damage due to improper installation or water connection.**

Warranty



**One Year Anniversary Inspection
Full Three Year Warranty
Full Seven Year Warranty on Sealed System Components
Limited Twelve Year Warranty on Sealed System Components**

One Year Anniversary Inspection

Amana Appliances will inspect the refrigerator for proper operation within 90 days of the first year anniversary date. Inspection is contingent upon the consumer scheduling a service call with an **authorized** Amana technician.

First through Third Years

Amana Appliances will repair or replace, free of charge, any part which is defective due to workmanship or materials. Adjustments covered during first year only.

Fourth through Seventh Years

Amana Appliances will repair or replace, free of charge, any sealed system component (compressor, condenser, evaporator, and interconnecting tubing) which is defective due to workmanship or materials.

Eighth through Twelfth Years

Amana Appliances will replace any sealed system component (compressor, condenser, evaporator and interconnecting tubing), f.o.b. Amana, Iowa, which is defective due to workmanship or materials.

Warranty Limitations

- Begins at date of original purchase.
- Applies to product used within the United States or in Canada if product has Canadian Standards Association listing when shipped from the factory.
- Service must be performed by an **authorized** Amana technician.

Warranty Is Void If

- Serial plate is defaced.
- Product is used on a commercial, rental or leased basis.
- Product has defect or damage due to product accident, alteration, connection to an improper electrical supply, fire, flood, lightning, shipping and handling, or other conditions beyond the control of Amana Appliances.
- Product is improperly installed or used.

Owner's Responsibilities

- Provide proof of purchase (sales receipt).
- Provide normal care and maintenance. Replace owner replaceable items where directions appear in Owner's Manual.
- Make product reasonably accessible for service.
- Pay premium service costs for service outside technician's normal business hours.
- Pay for service calls related to product installation.

In no event shall Amana Appliances be liable for incidental or consequential damages including food loss*.

*This warranty gives you specific legal rights and you may have others which vary from state to state. For example, some states do not allow the exclusion or limitation of incidental or consequential damages so this exclusion may not apply to you.

Any questions regarding the above or to locate an authorized servicer, contact:

Amana Appliances
Amana, Iowa 52204-0001
1-800-628-5782 inside U.S.A.
1-319-622-5511 outside U.S.A.