

OWNERS MANUAL

MODEL NO.
934.53734090
SERIES

KNOW YOUR UNIT

Read this booklet so you will be able to enjoy all the features in your video camera/recorder.

Record in space provided below the Model No. and the Serial No. as found on the label on the rear of your video camera/recorder.

Model No. _____

Serial No. _____

Retain this information for future reference.

L46-381313-3



VHS

VIDEO CAMERA/ RECORDER Operation

WARNING: TO PREVENT FIRE OR SHOCK HAZARD, DO NOT EXPOSE THIS UNIT TO RAIN OR MOISTURE.

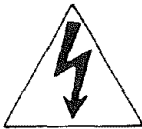

CAUTION
RISK OF ELECTRIC SHOCK
DO NOT OPEN

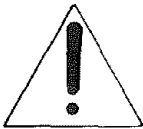

This symbol warns the user that uninsulated voltage within the unit may have sufficient magnitude to cause electric shock. Therefore, it is dangerous to make any kind of contact with any inside part of this unit.

CAUTION: TO REDUCE THE RISK OF ELECTRIC SHOCK, DO NOT REMOVE COVER (OR BACK). NO USER — SERVICEABLE PARTS INSIDE. REFER SERVICING TO QUALIFIED SERVICE PERSONNEL.



This symbol alerts the user that important literature concerning the operation and maintenance of this unit has been included. Therefore, it should be read carefully in order to avoid any problems.

DEW (MOISTURE CONDENSATION)

"DEW" ("POWER") Light indicates condensation on the recorder mechanism. If the video camera/recorder is moved from a cold area to a warm area and the humidity is high, moisture can form on the metal surface of the recording mechanism. If this happens, the tape could be damaged. To prevent damage the video camera/recorder will not operate except for "EJECT". Should "DEW" ("POWER") Light flash with the power on, press "EJECT" and remove the cassette. Wait for the moisture to dry (until "DEW" Light stop flashing).

NOTE: "POWER" Light is used as "DEW" Light. When "POWER" Light is continuously on, it is the "POWER" Indicator. When it flashes, it is the "DEW" Indicator.

"DEW" ("POWER") Light

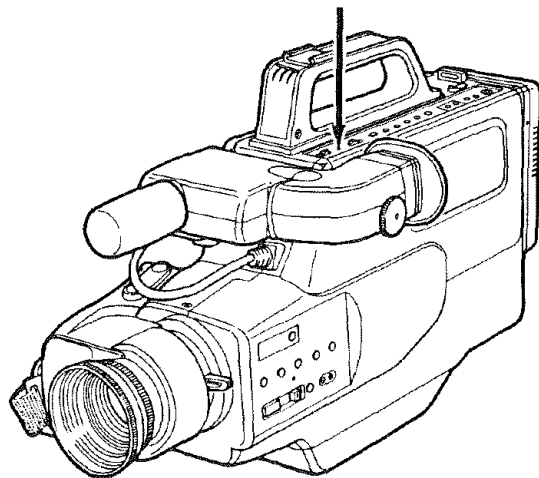

PRECAUTIONS

■ No water, dust or sand

Be careful that no water, dust or sand enters the Camera/Recorder because it may cause damage.

■ The solid-state image sensor is basically immune to direct sunlight or excessively bright objects, however, avoid prolonged exposure to these adverse objects since unnecessary heat may develop.

■ When you are not using the Camera/Recorder, switch off the power and attach the lens cap.

■ When you shoot at a scene which contains an extremely bright object such as the sun or a light source, a bright vertical bar may appear in the picture.

Your Camera/Recorder is functioning properly, but the solid-state pickup device (C.C.D) usually causes this as an inherent characteristic. Try to avoid shooting an excessive bright object directly.

■ Be sure not to leave it in a place where the temperature exceeds 122°F, or the pickup device will deteriorate. Be careful not to leave the unit in the following places:

- Inside a car with the windows closed and in direct sunshine.
- Near heating appliances.
- In direct sunshine in summer.

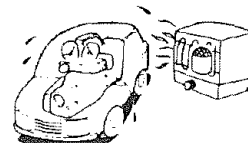
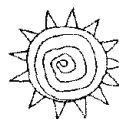

■ Do not leave the viewfinder lens facing sunlight for a prolonged period, or the phosphorescent surface of the cathode ray tube may be damaged.

Congratulations on buying the **VHS** Video Camera/Recorder. For maximum pleasure and convenience please read these simple instructions before operating your Camera/Recorder.

- NOTES:**
- This Video Camera/Recorder is compatible with any video cassette bearing the **VHS** mark.
 - **VHS** is designed to expand your opportunities for in-home TV viewing and not for any usage which might violate the copyright laws.
 - **HQ** The Video Camera/Recorder with this marking incorporates **VHS** high-quality picture technology and is compatible with any Video Cassette Recorders bearing the **VHS** mark.

FEATURES

- CCD solid-state camera pickup
- **HQ** High Quality picture technology
- Auto Focus Power Zoom Lens with macro feature
- Electronic Viewfinder
- Full record and playback capability with standard **VHS** cassette
- Flying Erase Head
- Video dub
- Audio dub
- Time and Date
- Titler
- Index Signal
- High speed shutter
- DC Camera Light

ACCESSORIES

Check to make sure you have the following components and accessories (besides the Camera/Recorder Unit itself) before disposing of the packing material.

1. Carrying Case
2. Lead-acid rechargeable Battery Pack (1-hour type)
3. AC Adaptor/Charger
4. Audio/Video Output Cable
5. DC Camera Light
6. Telephoto Lens
7. Clock Battery 3-volt Micro Lithium Cell (such as Maxell #CR2025 or equivalent)
8. RF Converter and 75-ohm Coaxial Cable with Antenna Adaptor (*) (Part No. 46-83930-3)
9. Wide-angle Lens (*) (Part No. 46-83870-3)
10. Synchro Edit Cord (*) (Part No. 46-23890-3)
11. Car Battery Cord (*) (Part No. 46-23858-3)
12. Earphone (*) (Part No. 33-8-2)
13. Antenna Adaptor (*) (Part No. 46-45733-3)
14. Audio/Video Input Cable (*) (Part No. 46-23765-3)

(*) Optional — not supplied.
Order from any Sears Service/Parts Department, mentioning the part number, Div. 57, Price List 528.

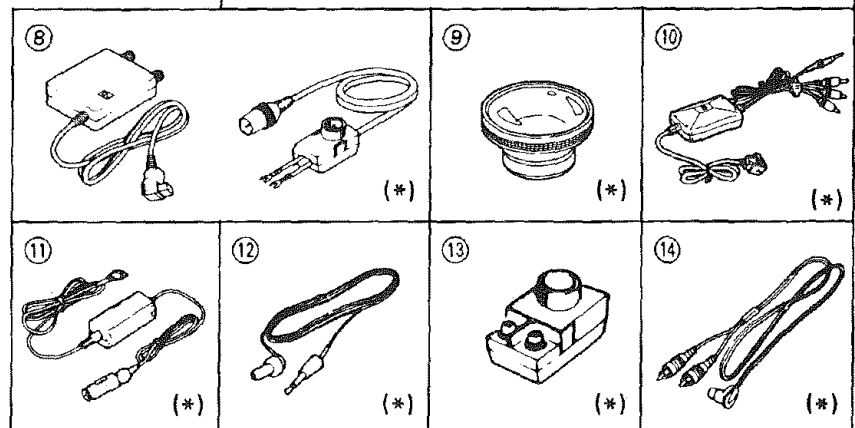
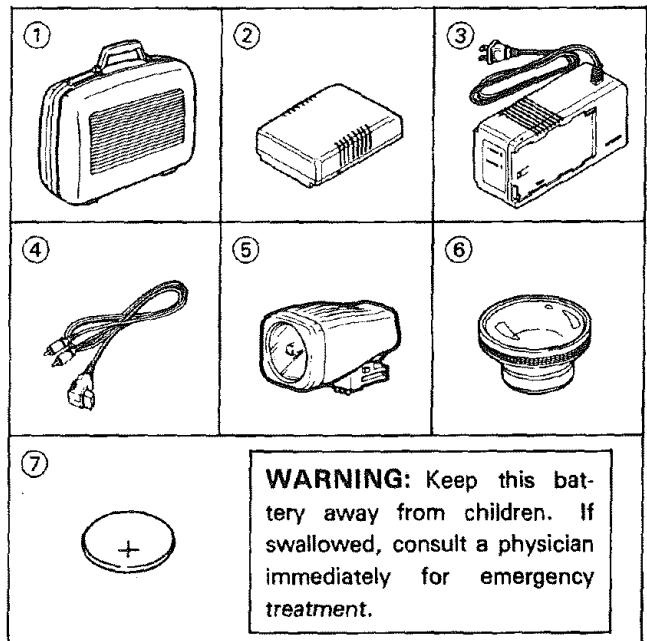

IMPORTANT SAFEGUARDS

In addition to the careful attention devoted to quality standards in the manufacture of your video product, safety is a major factor in the design of every instrument. But, safety is your responsibility too.

This page lists important information that will help to assure your enjoyment and proper use of a Video Camera/Recorder and accessory equipment. Please read it carefully before operating your video product and keep it in a handy place for future reference.

INSTALLATION

- 1 Read and Follow Instructions**—All the safety and operating instructions should be read before the video product is operated. Follow all operating and use instructions.

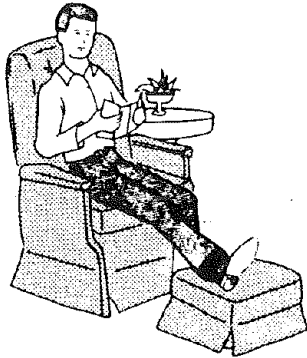

- 2 Retain Instructions**—The safety and operating instructions should be retained for future reference.
- 3 Heed Warnings**—Comply with all warnings on the video product and in the operating instructions.

4 Polarized Plug—This video product is equipped with a polarized alternating-current line plug (a plug having one blade wider than the other). This plug will fit into the power outlet only one way. This is safety feature. If you are unable to insert the plug fully into the outlet, try reversing the plug. If the plug should still fail to fit, contact your electrician to replace your obsolete outlet. To prevent electric shock do not use this polarized plug with an extension cord, receptacle or other outlet unless the blades can be fully inserted without blade exposure. If you need an extension, use a polarized cord.

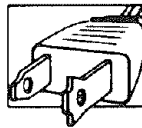

5 Power Sources—This video product should be operated only from the type of power source indicated on the marking label. If you are not sure of the type of power supply to your home, consult your video dealer or local power company. For video products intended to operate from battery power, or other sources, refer to the operating instructions.

6 Overloading—Do not overload wall outlets and extension cords as this can result in a risk of fire or electric shock. Overloaded AC outlets and extension cords are dangerous, and so are frayed power cords, damaged or cracked wire insulation and broken plugs. They may result in a shock or fire hazard. Periodically examine the cord and have it replaced by your service technician if appearance indicates damage or deteriorated insulation.

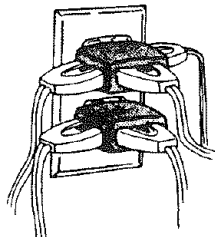

- 7 Power-Cord Protection**—Power-supply cords should be routed so that they are not likely to be walked on or pinched by items placed upon or against them, paying particular attention to cords at plugs, convenience receptacles, and the point where they exit from the appliance.

8 Ventilation—Slots and openings in the cabinet are provided for ventilation to ensure reliable operation of the video product and to protect it from overheating. These openings must not be blocked or covered. The openings should never be blocked by placing the video product on a bed, sofa, rug, or other similar surface. This video product should never be placed near or over a radiator or heat register. This video product should not be placed in a built-in installation such as a bookcase or rack unless proper ventilation is provided or the video product manufacturer's instructions have been followed.

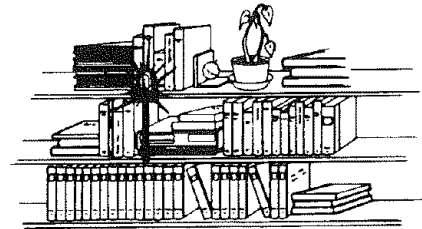

- 9 Attachments**—Do not use attachments unless recommended by the video product manufacturer as they may cause hazards.

Caution: Maintain electrical safety. Powerline operated equipment or accessories connected to this unit should bear the UL listing mark or CSA certification mark on the accessory itself and should not have been modified so as to defeat the safety features. This will help avoid any potential hazard from electric shock or fire. If in doubt, contact qualified service personnel.

- 10 Water and Moisture**—Do not use this video product near water—for example, near a bath tub, wash bowl, kitchen sink, or laundry tub, in a wet basement, or near a swimming pool, and the like.

11 Accessories—Do not place this video product on an unstable cart, stand, tripod, bracket, or table. The video product may fall, causing serious injury to a child or adult, and serious damage to the appliance. Use only with a cart, stand, tripod, bracket, or table recommended by the manufacturer, or sold with the video product. Any mounting of the product should follow the manufacturer's instructions, and should use a mounting accessory recommended by the manufacturer.

11A An appliance and cart combination should be moved with care. Quick stops, excessive force, and uneven surfaces may cause the appliance and cart combination to overturn.



53125A

12 Outdoor Antenna Grounding—If an outside antenna or cable system is connected to the video product, be sure the antenna or cable system is grounded so as to provide some protection against voltage surges and built-up static charges. Section 810 of the National Electrical Code, ANSI/NFPA No. 70-1984, provides information with respect to proper grounding of the mast and supporting structure, grounding of the lead-in wire to an antenna discharge unit, size of grounding conductors, location of antenna-discharge unit, connection to grounding electrodes, and requirements for the grounding electrode. See example below.

EXAMPLE OF ANTENNA GROUNDING

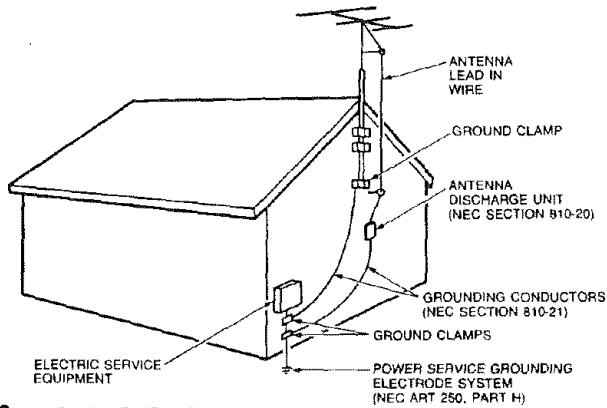

NEC — NATIONAL ELECTRICAL CODE

13 Power Lines—An outside antenna system should not be located in the vicinity of overhead power lines or other electric light or power circuits, or where it can fall into such power lines or circuits. When installing an outside antenna system, extreme care should be taken to keep from touching or approaching such power lines or circuits as contact with them might be fatal. Installing an outdoor antenna can be hazardous and should be left to a professional antenna installer.

USE

14 Cleaning—Unplug this video product from the wall outlet before cleaning. Do not use liquid cleaners or aerosol cleaners. Use a damp cloth for cleaning.

15 Object and Liquid Entry—Never push objects of any kind into this video product through openings as they may touch dangerous voltage points or short-out parts that could result in a fire or electric shock. Never spill liquid of any kind on the video product.

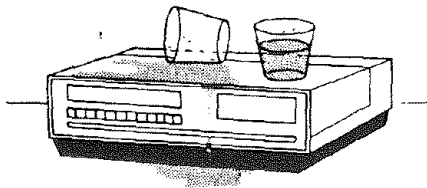

16 Lightning—For added protection for this video product during a lightning storm, or when it is left unattended and unused for long periods of time, unplug it from the wall outlet and disconnect the antenna or cable-system. This will prevent damage to the video product due to lightning and power-line surges.

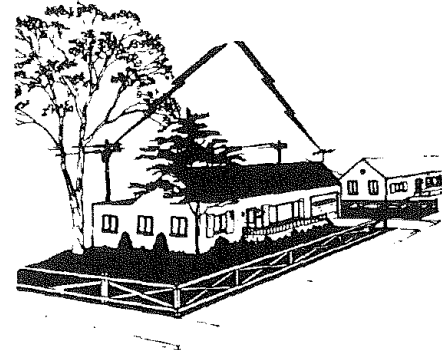

SERVICE

17 Servicing—Do not attempt to service this video product yourself as opening or removing covers may expose you to dangerous voltage or other hazards. Refer all servicing to qualified service personnel.

18 Conditions Requiring Service—Unplug this video product from the wall outlet and refer servicing to qualified service personnel under the following conditions.

- a. When the power-supply cord or plug is damaged.
- b. If liquid has been spilled, or objects have fallen into the video product.
- c. If the video product has been exposed to rain or water.
- d. If the video product does not operate normally by following the operating instructions. Adjust only those controls that are covered by the operating instructions. Improper adjustment of other controls may result in damage and will often require extensive work by a qualified technician to restore the video product to its normal operation.
- e. If the video product has been dropped or the cabinet has been damaged.
- f. When the video product exhibits a distinct change in performance—this indicates a need for service.

19 Replacement Parts—When replacement parts are required, have the service technician verify that the replacements he uses have the same safety characteristics as the original parts. Use of replacements specified by the video product manufacturer can prevent fire, electric shock or other hazards.

20 Safety Check—Upon completion of any service or repairs to this video product, ask the service technician to perform safety checks recommended by the manufacturer to determine that the video product is in safe operating condition.

IMPORTANT SAFETY INSTRUCTIONS FOR AC ADAPTOR/CHARGER

1. **Save these instructions** — This page contains important safety and operating instructions for AC Adaptor/Charger Model VM-AC64AS.
2. Before using AC Adaptor/Charger, read all instructions and cautionary markings on (1) AC Adaptor/Charger, (2) battery and (3) product using battery.
3. Also read all instructions on pages 3 and 4.
4. **Caution** — To reduce risk of injury, charge only rechargeable battery, VM-BP64AS or 57-53982. Other types of batteries may burst causing personal injury and damage.
5. Do not expose charger to rain or snow.
6. Use of an attachment not recommended or sold by the battery charger manufacturer may result in a risk of fire, electric shock, or injury to persons.
7. To reduce risk of damage to electric plug and cord, pull by plug rather than cord when disconnecting charger.
8. Make sure cord is located so that it will not be stepped on, tripped over, or otherwise subjected to damage or stress.
9. Do not operate charger with damaged cord or plug — replace them immediately.

10. An extension cord should not be used unless absolutely necessary. Use of improper extension cord could result in a risk of fire and electric shock. If extension cord must be used, make sure:

- A. That pins on plug of extension cord are the same number, size, and shape as those of plug on charger.
- B. That extension cord is properly wired and in good electrical condition; and
- C. That wire size should be met below:

Minimum AWG size	Length of extension cord (feet)
18	Equal to or less than 100
16	Equal to or less than 150

11. Do not operate charger if it has received a sharp blow, been dropped, or otherwise damaged in any way; take it to a qualified serviceman.
12. Do not disassemble charger; take it to a qualified serviceman when service or repair is required. Incorrect reassembly may result in a risk of electric shock or fire.
13. To reduce risk of electric shock, unplug charger from outlet before attempting any maintenance or cleaning.

TABLE OF CONTENTS

Features.....	2	Title making	29
Accessories.....	2	Eyepiece adjustment	31
Important safeguards.....	3	Producing best color program	31
Important safety instructions for AC Adaptor/Charger.....	5	Viewing the picture played back on your TV	32
Electronic viewfinder position adjustment.....	7	Display button	34
Attaching the telephoto or wide-angle lens.....	7	Linear time counter.....	34
Loading battery for date/clock	7	Memory	35
Power sources	8	Time remaining.....	35
Battery pack checking.....	9	F-search and R-search	36
Charging the battery pack	10	Pause.....	36
Making a sample camera recording.....	11	Edit search	37
Identification and operation of controls.....	13	Operating hints	38
Auto focus	19	Camera/Recorder to VCR dubbing.....	38
Power zoom	21	Flying erase head.....	38
Macro lens	21	Troubleshooting.....	39
Instant review.....	21	Storing the Camera/Recorder in the carrying case	40
Variable shutter speed.....	22	Routine maintenance	41
Auto iris.....	22	Sears service	41
Recording TV program	23	How to order repair parts.....	41
Audio dubbing.....	24	Specifications	41
Video dubbing	25	Using the optional synchro edit cord.....	42
Index signal recording	26		
Date/clock setting	27		
Attaching the DC camera light	28		

“Note to CATV system installer: This reminder is provided to call the CATV system installer’s attention to Article 820–22 of the NEC that provides guidelines for proper grounding and, in particular, specifies that the cable ground shall be connected to the grounding system of the building, as close to the point of cable entry as practical”.

ELECTRONIC VIEWFINDER POSITION ADJUSTMENT

The position of the Electronic Viewfinder can be adjusted so it can be viewed with the left eye as well as the right eye.

- **When viewing with right eye**

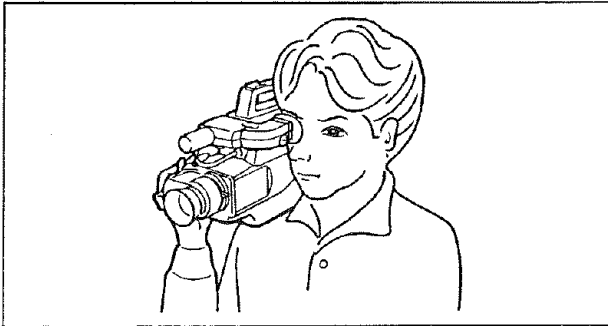

- **When viewing with left eye**

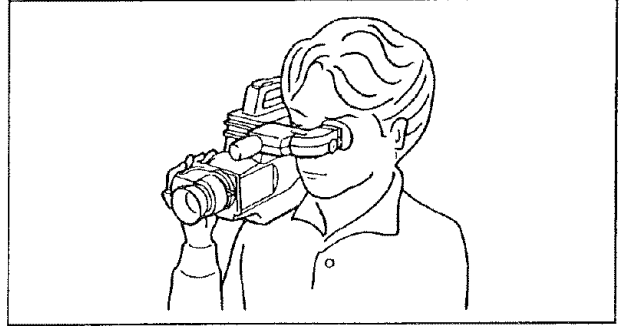

ATTACHING THE TELEPHOTO OR WIDE-ANGLE LENS

Use the Telephoto attachment if you wish to make your subject appear larger or the Wide-angle attachment to make your subject appear wider.

1. To remove Lens Hood, put hand flat against Lens Hood and turn it counterclockwise.

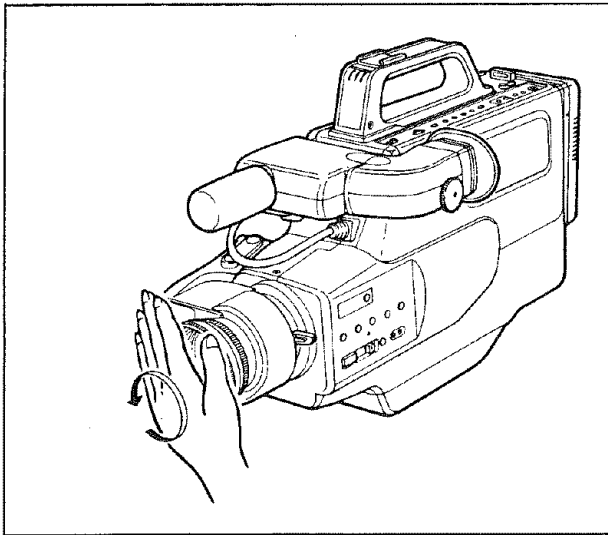

2. Remove both caps of the Telephoto Lens (Accessory No. 6) or Wide-angle Lens (Optional Accessory).
3. Screw the lens into the threads on the front of Video Camera/Recorder lens assembly.

NOTES:

- Auto focusing will not operate correctly when the Telephoto or Wide-angle lens is attached to the Video Camera/Recorder.
- Shading at corners may occur near the Wide-angle end (extreme of your zoom lens) and in the macro position.

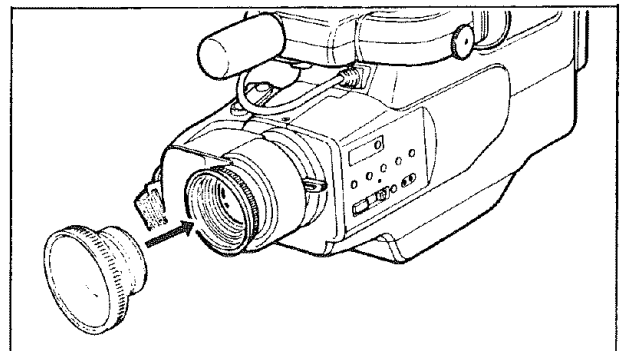

LOADING BATTERY FOR DATE/CLOCK

You may want to install the clock battery (Accessory No. 7) immediately to prevent misplacing it.

1. Pull the tab to open the cover and expose the compartment.
2. Insert the clock battery with the "+" terminal facing out (as illustrated inside the battery cover).
3. Gently push the cover closed until it snaps into place.

NOTES:

- When replacing the batteries, use 3V micro lithium cell such as Maxell CR2025 or equivalent.
- Instructions for setting the time and date are on page 27. You can do that later if desired after you're more familiar with your camera/recorder.

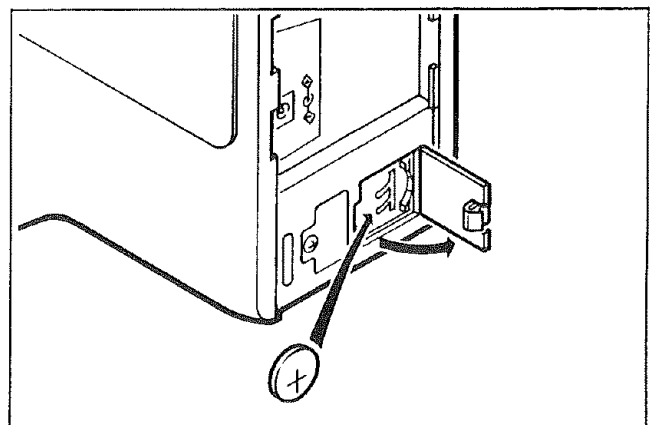

POWER SOURCES

■ WHEN USING WITH THE BATTERY PACK (Accessory No. 2)

1. To attach align the mark "▶" on the side of the Battery Pack (Accessory No. 2) with that on the rear left side of the Video Camera/Recorder so that the Battery fits in the grooves (flat against the rear of the Camera/Recorder), and slide the Battery Pack downward, as illustrated.
2. To remove slide the Battery Pack upward while pushing the "BATTERY" Eject Lever in the direction of the arrow.

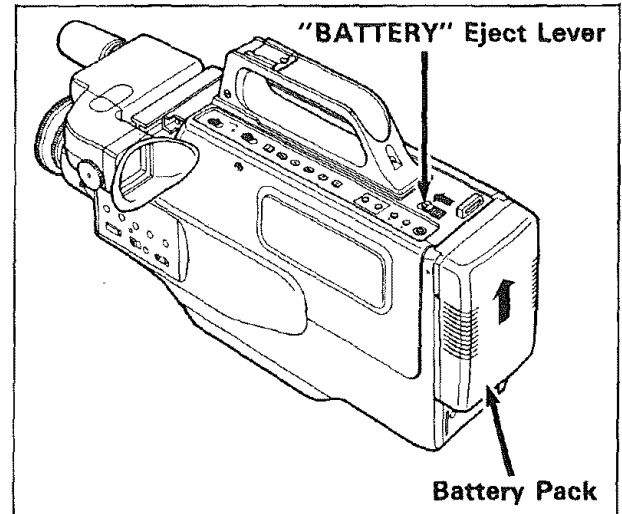
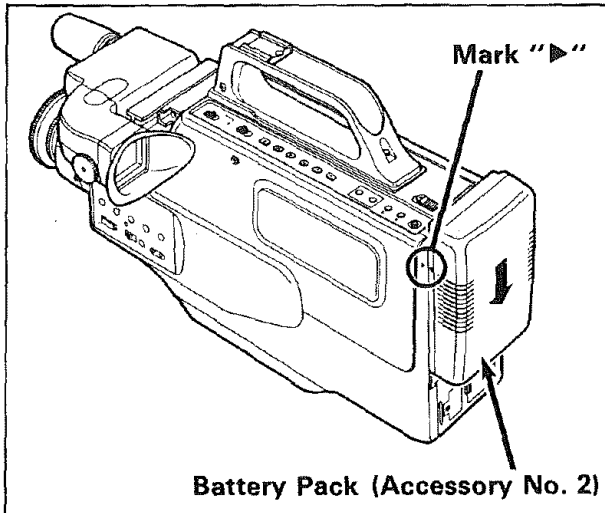

■ WHEN USING WITH THE AC ADAPTOR/CHARGER (Accessory No. 3)

See the rating label of the AC Adaptor/Charger.

1. To attach align the mark "▶" on the side of the AC Adaptor/Charger (Accessory No.3) with that on the side of the Video Camera/Recorder so that it fits into the grooves (flat against the rear of the Camera/Recorder), and slide the AC Adaptor/Charger downward as illustrated.
2. Plug the AC Adaptor/Charger power cord into AC electrical outlet.

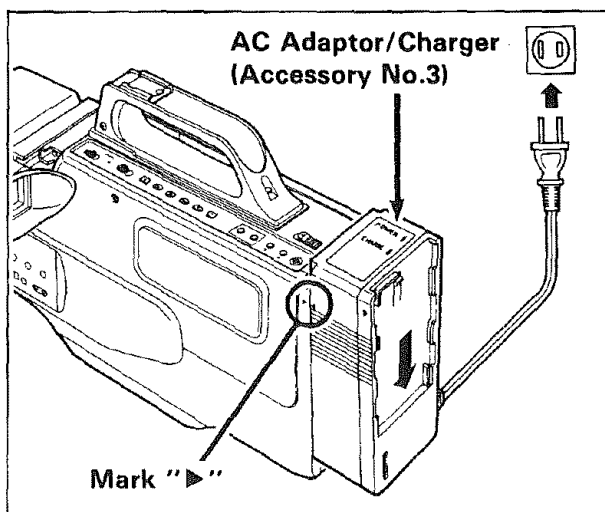

3. To remove slide the AC Adaptor/Charger upward while pushing the "BATTERY" Eject Lever in the direction of the arrow.

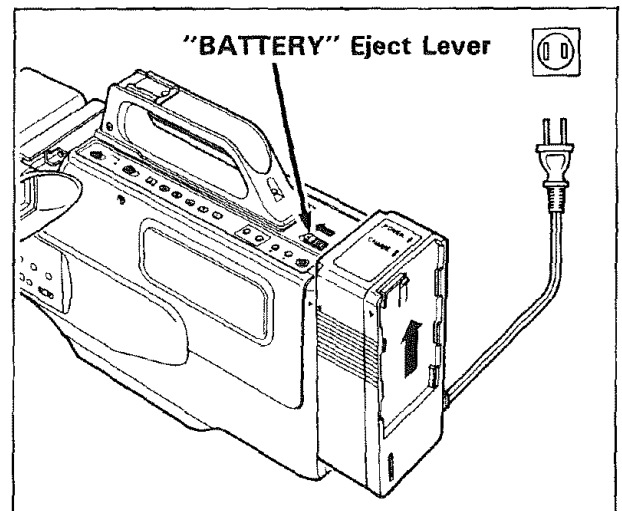

NOTES:

- The AC Adaptor/Charger cannot charge the Battery and operate the Camera/Recorder at the same time. Remove the Battery from the AC Adaptor/Charger to supply power to the Camera/Recorder.
- When using the AC Adaptor/Charger to power the Camera/Recorder, the battery level indicator may display "E—". This indicator is used for battery operation and has no meaning when using the AC Adaptor/Charger to power the Camera/Recorder.

■ WHEN USING WITH THE CAR BATTERY

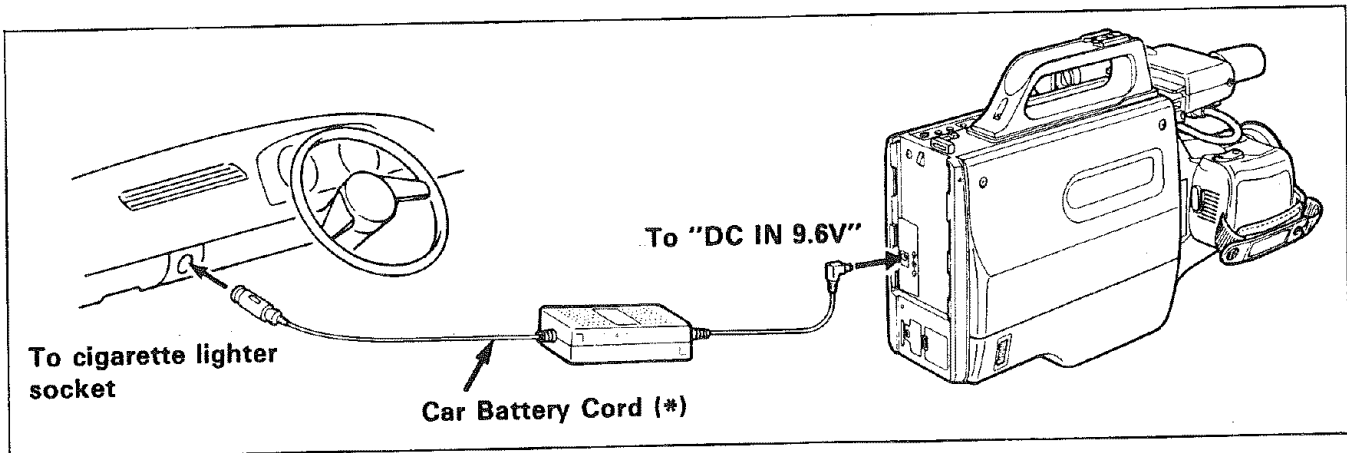

1. Connect the small plug of the Car Battery Cord to the "DC IN 9.6V" jack of the Camera/Recorder.
 2. Connect the other of the Car Battery Cord to the car's cigarette lighter socket.
- (*) Optional — not supplied.
See page 2 for ordering information.

NOTES:

- The Car Battery Cord is designed to be used only with automobiles having a 12-volt negative ground system.
- To avoid possible damage to your Camera/Recorder, make sure the Car Battery Cord you plan to use has positive tip polarity and is capable of converting 12 volts to 9.6 volts such as Sears Part No. 46-23858-3.

BATTERY PACK CHECKING

When the "E" indication in the Electronic Viewfinder appears and flashes while the Video Camera/Recorder is operated with a Battery pack (Accessory No. 2) during recording, it indicates that the battery charge is insufficient. Then, charge it or replace it with a charged battery pack.

NOTE: Whenever the linear time counter or tape remaining display is present in the viewfinder, it appears with a 3-dash read-out indicating the condition of Camera/Recorder battery power. When the battery is fully charged, the display reads "E---F". When the battery is very near empty, only one dash remains and starts blinking. You should find an alternative power source or recharge the battery before continuing to use your Camera/Recorder.

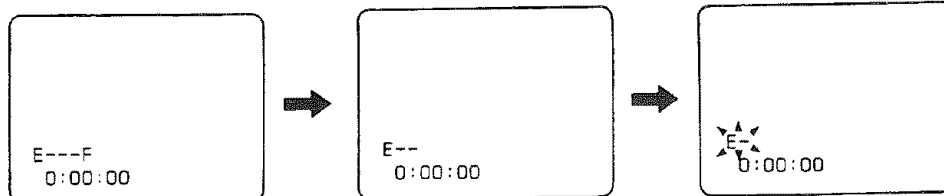
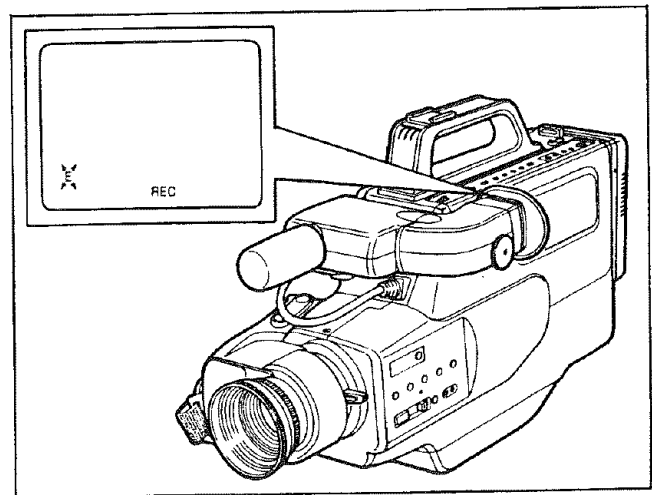

CHARGING THE BATTERY PACK

1. Plug the AC Adaptor/Charger (Accessory No. 3) power cord into AC electrical outlet.
2. Attach the Battery to the AC Adaptor/Charger. Align the reference arrow on the Battery with that of AC Adaptor/Charger and push the Battery flush with the AC Adaptor/Charger and slide it in the direction of arrow.

NOTE: When a Battery is attached to the AC Adaptor/Charger, do not turn them upside down. The Battery may fall off and be damaged or cause injury.

3. The "CHARGE" Light will be lit while the Battery is accepting a charge, and will go out when the Battery is fully charged.

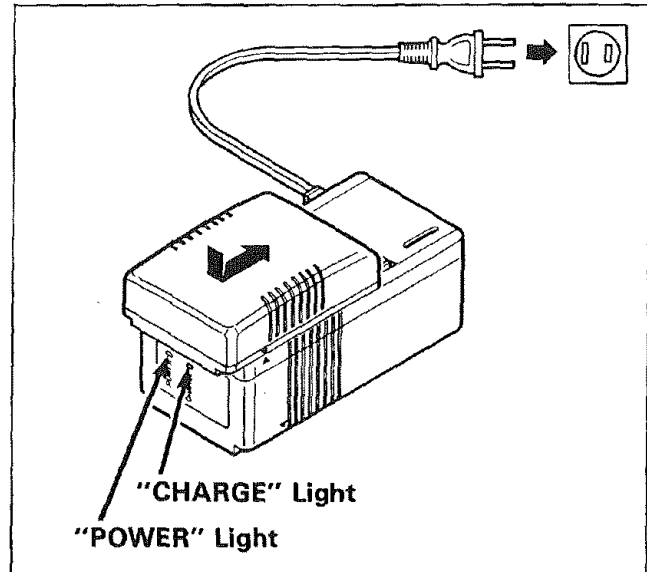

NOTES:

1. The time required for charging the Battery is approx. two hours.
2. When fully charged, the Battery should supply approx. 45 ~ 60 minutes of operating time (depending on how much you use zoom and pause).
3. An optional long play battery (Sears Stock No. 57-53982) may also be charged by the AC Adaptor/Charger. The time for battery charging is approx. three hours.
4. Charge the Battery after use and store it at normal room temperature.
5. Recharge your Battery at least once every six months. The Battery is a Lead-acid Battery. This Battery tends to discharge if not used for an extended period of time. If the Battery is stored for a extended length of time without being recharged, you may not be able to recharge it.
6. A Battery charged after being stored for a long period may not supply power for the specified time. Additional rechargings will help restore the Battery's operation time.
7. The Battery should be charged at a temperature of 32°F — 95°F (0°C — 35°C) to prevent damage.
8. Do not operate the Battery at temperatures below 14°F (—10°C) or above 95°F (35°C). The Battery may be damaged if operated at temperatures above 122°F (50°C). Operation time will decrease at extremely low temperatures.
9. After repeated chargings and use, the operation time will gradually decrease. When operation time becomes too short to be useful, it is time to replace the Battery.
10. If "CHARGE" and "POWER" Lights on the AC Adaptor/Charger start flashing, remove the battery and then reattach it. If after several attempts both Lights continue to flash, this means your battery cannot take a charge and must be replaced with a new one. Both Lights will also flash if a hot battery is attached to the AC Adaptor/Charger. Attaching an extremely hot Battery to the AC Adaptor/Charger is not recommended; it should be allowed to cool down before being attached.
11. Do not short the Battery's terminal.
12. Do not attempt to disassemble or modify the Battery. There are no user-serviceable parts inside.
13. Throwing the Battery into a fire or exposing the Battery to excessive heat — over 149°F (65°C) could be hazardous.

MAKING A SAMPLE CAMERA RECORDING

1. Connect the POWER SOURCE. (See pages 8 and 9.)
2. Press "EJECT" Button and insert the cassette so the transparent window is toward you and the arrow toward the Cassette Holder. Slide the Cassette into Cassette Holder as far as it will go.
NOTE: If the power source is not connected to Camera/Recorder, the Cassette Holder will not open.
3. Press the Cassette Holder. The Holder will latch in the operating position.

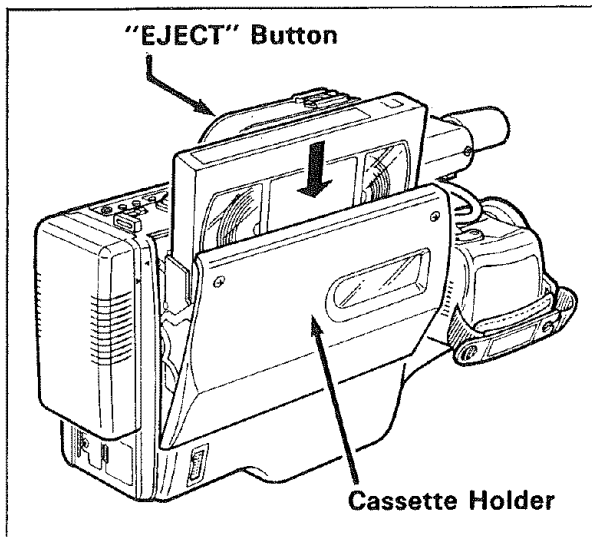

4. Set "VCR/CAM" Select Switch to "CAM" position.
5. Press "POWER" ON/OFF Button on. The Video Camera/Recorder will enter record/pause mode automatically.

NOTE: If the erase prevention tab on the cassette is removed or no cassette is inserted, "TAPE" in the viewfinder will flash for several seconds and the Camera/Recorder will not enter record/pause mode and recording is not possible.

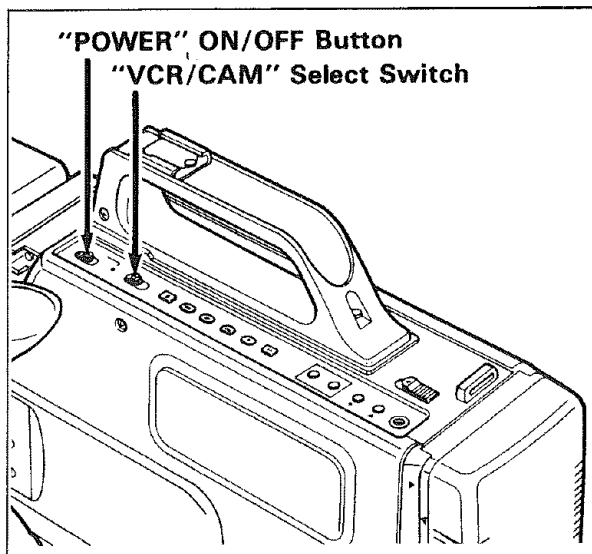

6. Set "FOCUS AUTO/MAN" Switch to "AUTO".
NOTE: See page 31 for "EYEPIECE ADJUSTMENT".

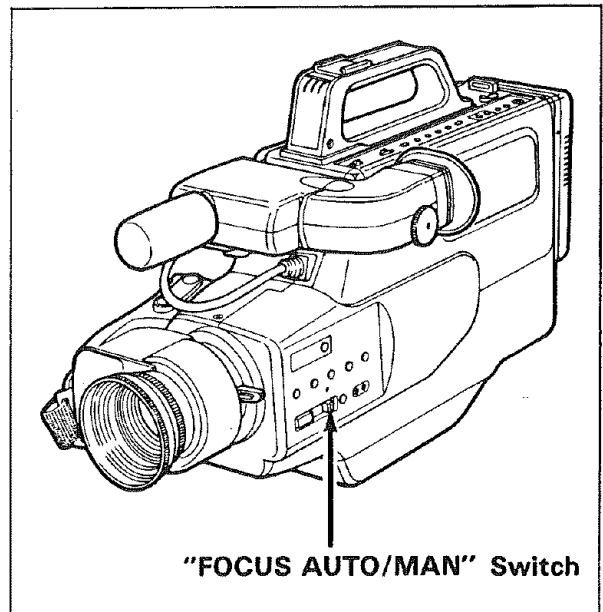

7. Now, press Record Start/Stop Button to start shooting the picture. "REC" indication appears in the viewfinder and you are now recording the picture you see through the Electronic Viewfinder.
8. Press Record Start/Stop Button to stop recording. Press the Button again to resume recording. The "REC" indication in the Electronic Viewfinder goes off in the record/pause (stand-by) mode.

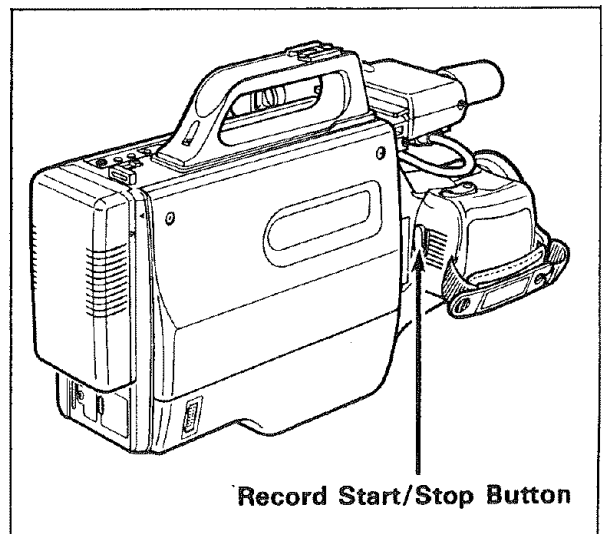

9. After recording, set "VCR/CAM" Select Switch to "VCR", and the Camera/Recorder will be now in the stop mode.

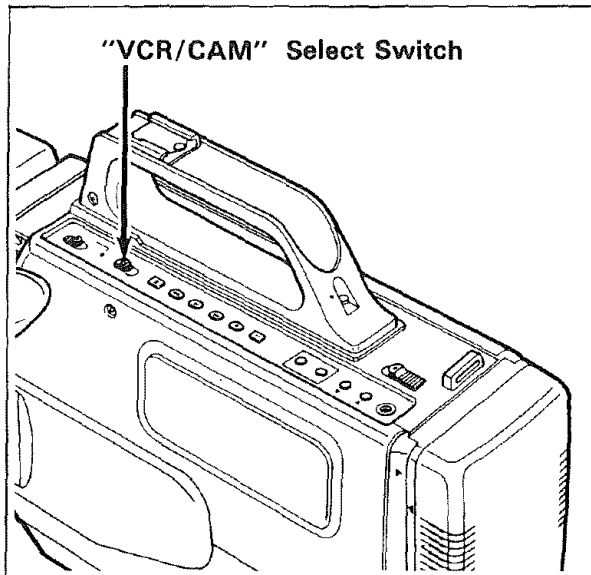

13. Press "POWER" ON/OFF Button off and then "EJECT" Button to remove cassette.

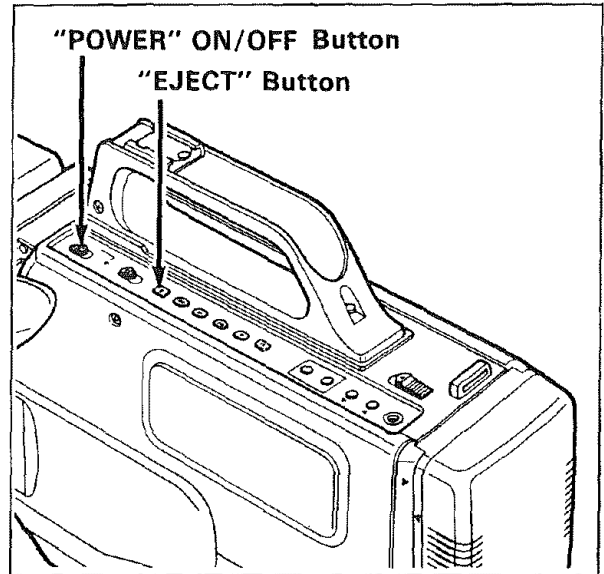

10. Press "REW" Button. The tape will be rewound to the beginning.
11. Press "PLAY" Button. The picture you just recorded will be seen through the Viewfinder and sound can be heard by earphone (Not supplied).
- NOTE:** If you connect the Video Camera/Recorder to your TV, you can see the picture played back on your TV. Refer to **VIEWING THE PICTURE PLAYED BACK ON YOUR TV** on pages 32 and 33.
12. After playing, press "STOP" Button.

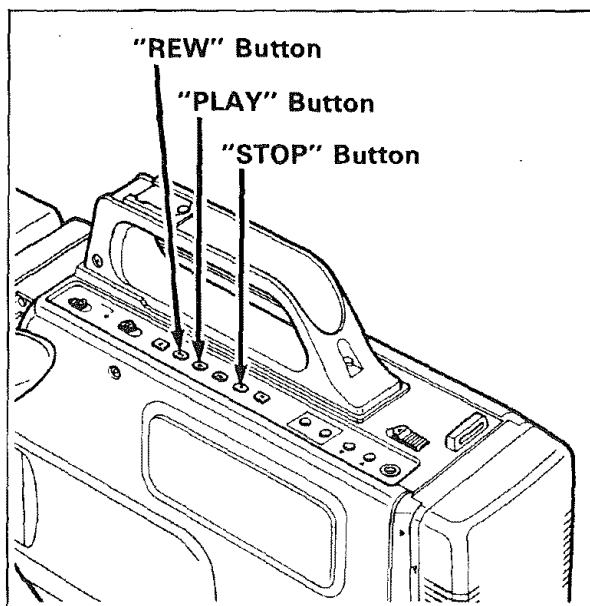

14. Always remove the power source from the Video Camera/Recorder after use.

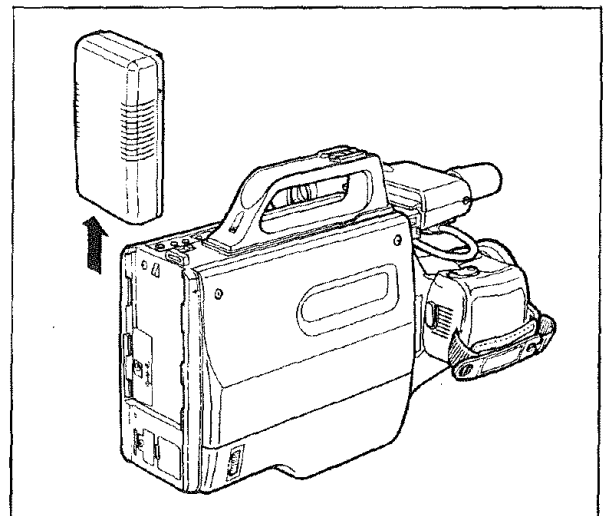

To prevent an accidental erasure of recorded material:

If you have a cassette tape that has already been partially recorded on and you want to record on the remaining blank section, see "EDIT SEARCH" on page 37.

IDENTIFICATION AND OPERATION OF CONTROLS

"MEMORY" Button

If this Button is pressed while the linear time counter or time remaining read-out is displayed in the viewfinder, "M" appears in the display and it memorizes the tape position of "0:00:00".

(See page 35.)

"DISPLAY" Button

Pressing this Button once causes a 5 digit linear time counter and battery indicator to appear in the Camera/Recorder's viewfinder.

Pressing the Button again will cause battery indicator and the amount of time remaining on the cassette in the Camera/Recorder. Press a third time to delete all displays.

Microphone

Sensitive to sounds coming from the direction in which the camera is pointed.

Zoom Ring (Manual Zooming)

The picture size can be magnified 6 times with the use of the zoom feature. Just rotate the Zoom Ring for a close up (T) or wide angle (W) picture. Macro close-up, as close as 1 cm from object, is feasible.

Auto Focus Window

To automatically focus the camera lens, this window transmits and receives infrared light which is reflected off the object. Make sure you don't obstruct this window when recording.

Focus Ring

Do not attempt to manually turn the Focus Ring when the Camera/Recorder is in the auto focus mode.

Lens (with Lens Cap)

F1.4 (9 ~ 54 mm) 6:1 power zoom lens features auto focus and auto iris functions.

"MACRO" Button

Used to shoot objects as close as 1 cm from the lens tip.

(See "MACRO LENS" on page 21.)

Cover for Camera Light Terminal

When the DC camera light (provided) is attached to the accessory shoe, this cover slides and power can be supplied to the DC camera light.

Caution: To help avoid any potential hazard from electric shock, do not open this cover when the camera light is not attached and the camera/recorder is turned on.

"PUSH AUTO" Focus Button

Auto focusing can be also performed during manual focus mode by pushing this Button.

Accessory Shoe

Used to attach the DC Camera Light (Accessory No. 5).

"BATTERY" Eject Lever

Releases the Battery or AC Adaptor/Charger attached to the Video Camera/Recorder.

Electronic Viewfinder (EVF)

Displays what the Camera/Recorder lens sees. The electronic viewfinder also functions as a convenient black-and-white monitor during playback of recorded material.

Diopter Control

To use the electronic viewfinder without eyeglasses on, turn this control knob for your optimum focus adjustment.

"SHUTTER" Button

Used to control the shutter speed during recording and/or record/pause (stand-by) mode. (See "VARIABLE SHUTTER SPEED" on page 22.)

"REVIEW" Button

Used to review the last few seconds of the recorded segment in the record/pause mode. (See page 21.)

"TITLE" Button

Press this Button to create and record personalized titles on your videos with the Camera/Recorder's built-in titler. (See "TITLE MAKING" on page 29.)

"RESET/T-160" Button

When the linear time counter is displayed in the viewfinder, pressing this Button resets the counter to "0:00:00".

When the time-remaining read-out is displayed, pressing this Button changes the display for extended length T-160 tapes, the indicator under the T-160 Button will light.

"DATE/TIME" Adjust Buttons

Used to set the date and clock during pause (stand-by) mode. (See "DATE/CLOCK SETTING" on page 27.)

"DATE/TIME ON/OFF" Button

Press this Button to display the date and clock in the viewfinder.

Whenever the date and clock appear in the viewfinder, they will be recorded on the tape.

"FOCUS AUTO/MAN" Switch

Set this Switch to the "AUTO" position for automatic focusing, and to the "MAN" position for focusing with the Focus Ring.

"EJECT" Button

Operates with "POWER" either on or off, if a power source is connected to the Camera/Recorder.

"POWER" Light and Dew Indicator Light

Flashing of the Light indicates dew condensation on Camera/Recorder mechanism. While this Light is flashing, the unit will not operate. Leave the power on until the Light stops flashing. Then the unit can be operated.

"POWER" ON/OFF Button

Press "POWER" ON/OFF Button to turn Camera/Recorder on. Press again to turn Camera/Recorder off.

"POWER" Light illuminates when "POWER" ON/OFF Button is pressed and Camera/Recorder is on.

"PLAY" Button

Used for playback of tape recorded in the SP mode.

NOTE: When the Camera/Recorder is in record/pause (stand-by) mode, pressing and holding this Button will play the tape at normal.

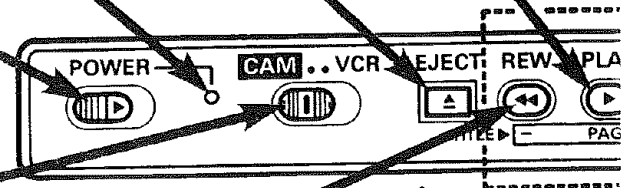

"VCR/CAM"era Select Switch

This Switch changes the Camera/Recorder to the record mode or to the playback mode. The Switch must be in "CAM"era position for recording.

"REWIND" Button

Press this Button during Stop or Fast forward mode, and fast-rewinding starts. "REWIND" appears in the viewfinder whenever the linear time counter or time remaining is present. Press the Button during playback of tape, and the tape is played back in the rewind direction approximately 3 times faster than the normal speed to confirm the recorded contents. Press "PLAY" Button to return to normal playback mode or press "STOP" Button to stop tape movement.

NOTE: You can also visually scan backward when the Camera/Recorder is in record/pause (stand-by) mode by pressing and holding this Button.

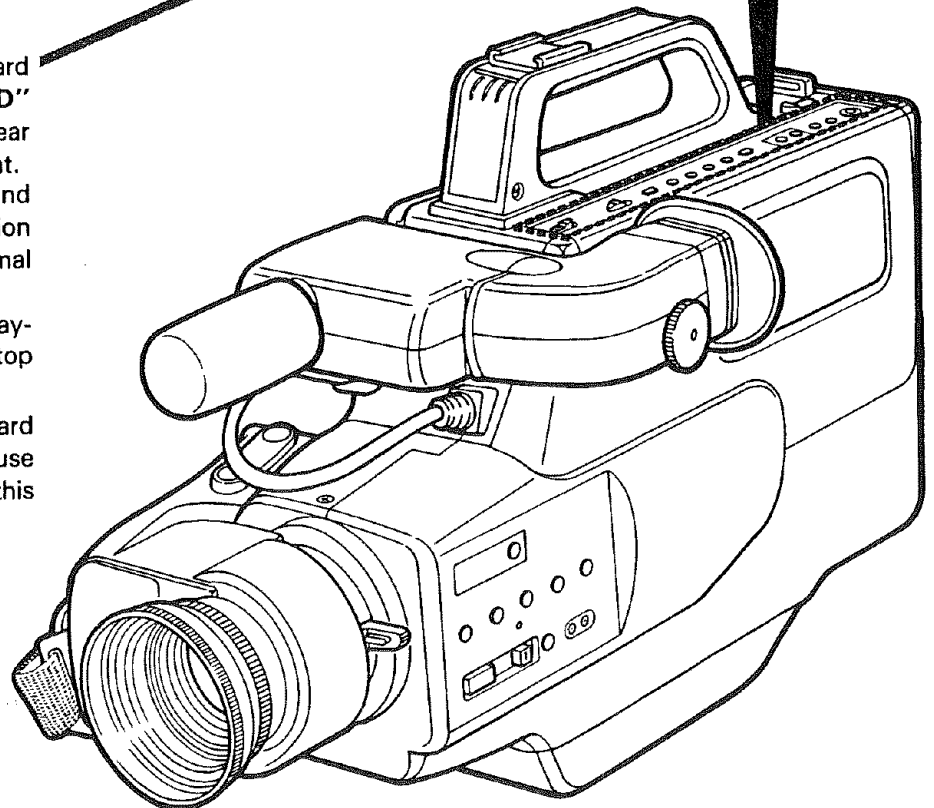

These buttons are used for title making buttons when the "TITLE" button is pressed. (See "TITLE MAKING" on page 29.)

"PAUSE/REC" Button

When this Button is pressed during recording, the tape stops and the Camera/Recorder enters the record/pause (stand-by) mode. When this Button is pressed again, the tape runs to resume recording.

NOTE: This Button may be also used to display a still picture during playback mode.

"AUDIO DUB" Button

This button is used to record new audio in place of existing audio without erasing the video. See page 24.

"TRACKING" Control

Used when playing a tape recorded on another VCR. Adjust for best picture. Ejecting the cassette returns the tracking to the normal position.

"EAR"phone Jack

Sound being recorded by the microphone or played back may be monitored by attaching earphone (Not supplied) to this jack.

"VIDEO DUB" Button

This Button is used to record new video in place of existing video without erasing the audio. See page 25.

"STOP" Button

The "STOP" Button is used to stop playback, rewind, and fast forward operations. The "STOP" Button has no effect during record operation.

"F.FWD" Button

Press this Button during Stop or Rewind mode, and fast-forwarding starts. "FAST FWD" appears in the viewfinder whenever the linear time counter or time remaining is present. Press the Button during playback of tape, and the tape is played back in the forward direction approximately 3 times faster than the normal speed to confirm the recorded content. Press "PLAY" Button to return to normal playback mode or press "STOP" Button to stop tape movement.

NOTE: You can also visually scan forward when the Camera/Recorder is in record/pause (stand-by) mode by pressing and holding this Button.

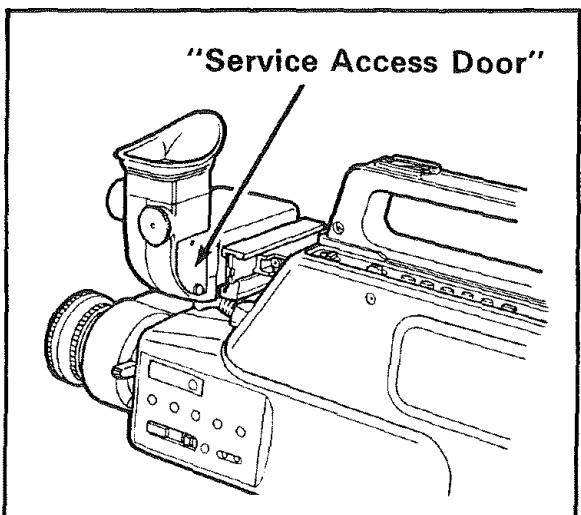
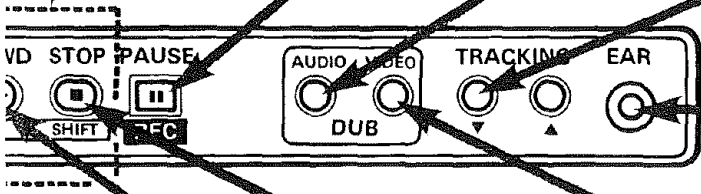

"AV OUT" Jack

Connect the Audio/Video Output Cable (Accessory No. 4) to this jack and to the audio and video inputs of your TV/monitor receiver. You may also connect the RF Converter Unit (Optional) to this jack and your TV receiver.

Cassette Holder

Press "EJECT" Button to open the Cassette Holder. Be aware of the Cassette direction when inserting.

NOTE: Power source must be connected to open the Cassette Holder.

Clock Battery Compartment

Pull the tab to open the cover and install the Clock Battery (Accessory No. 7).

"DC IN 9.6V" Jack

When using the Car Battery Cord (optional), connect this jack and the car's cigarette lighter socket.

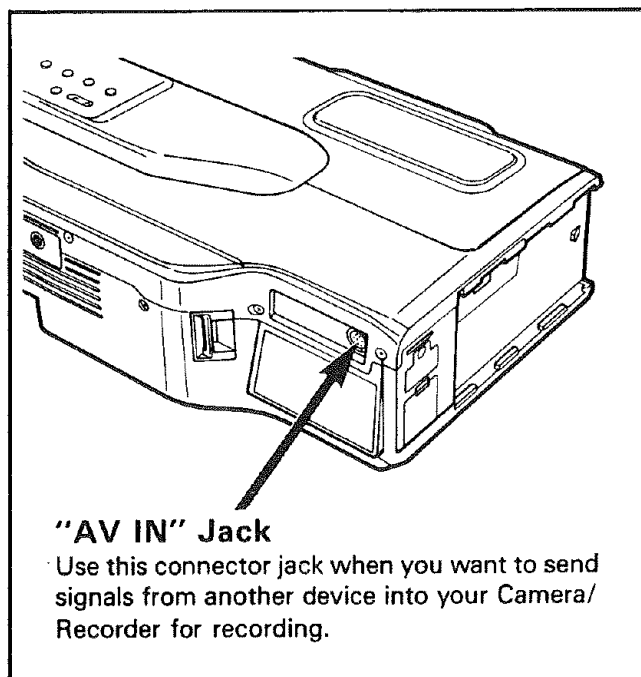

"AV IN" Jack

Use this connector jack when you want to send signals from another device into your Camera/Recorder for recording.

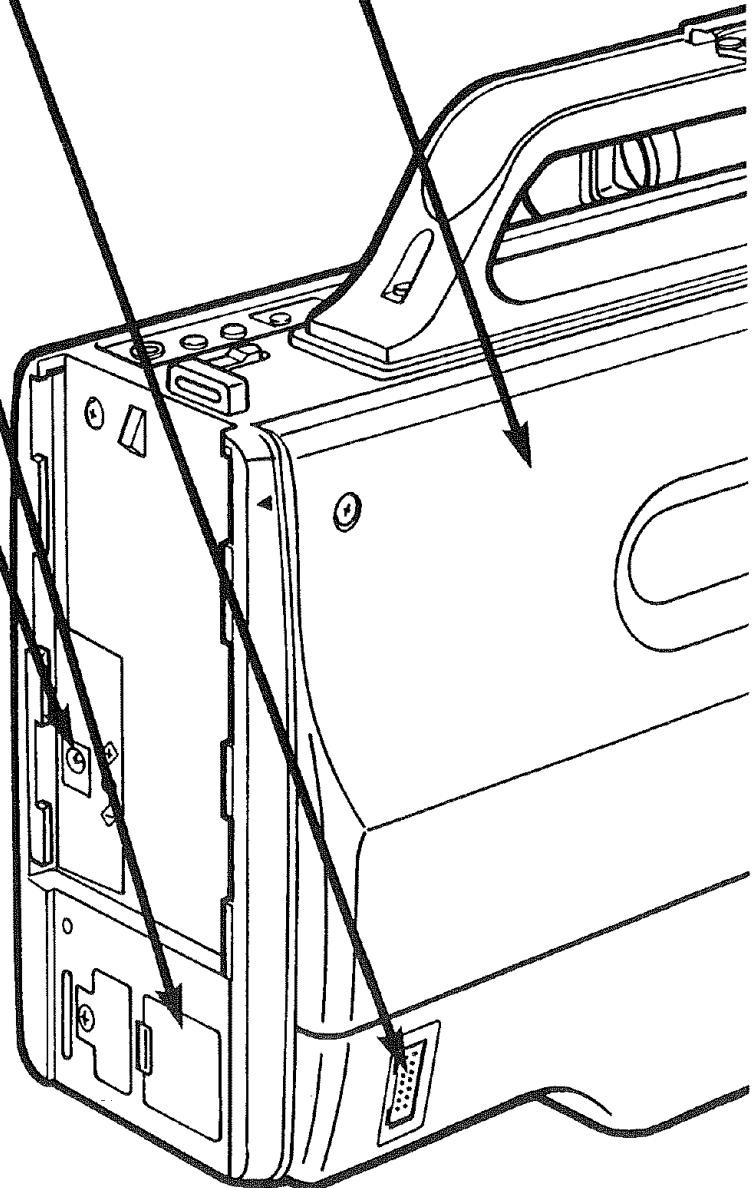

Graphics in the Electronic Viewfinder

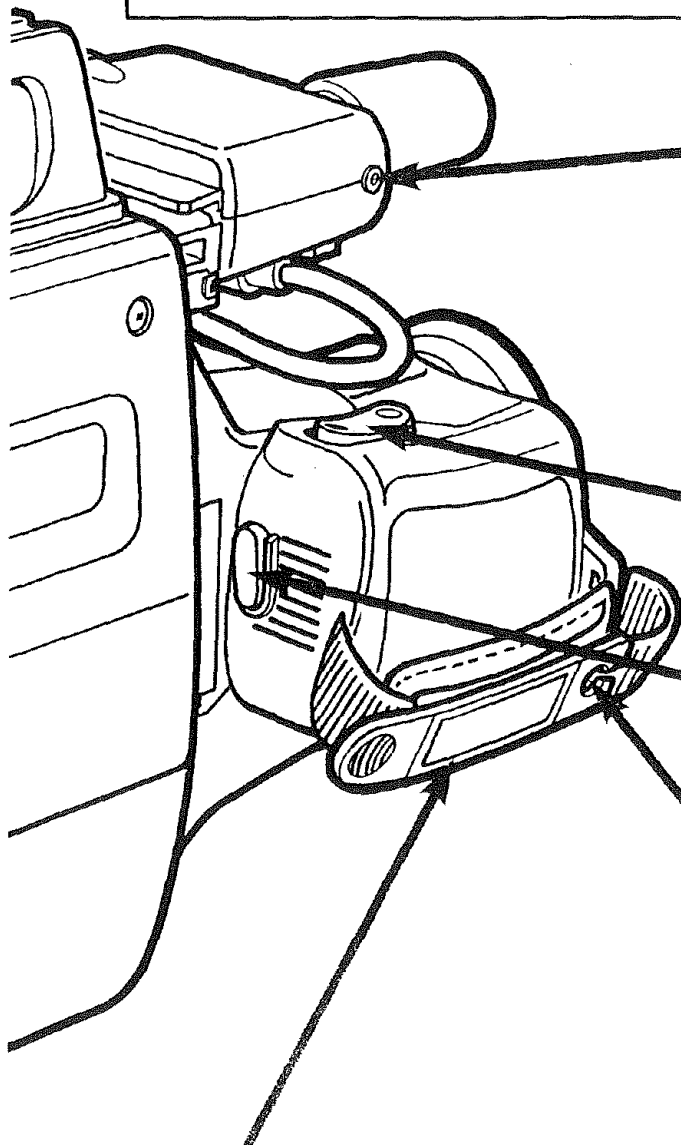
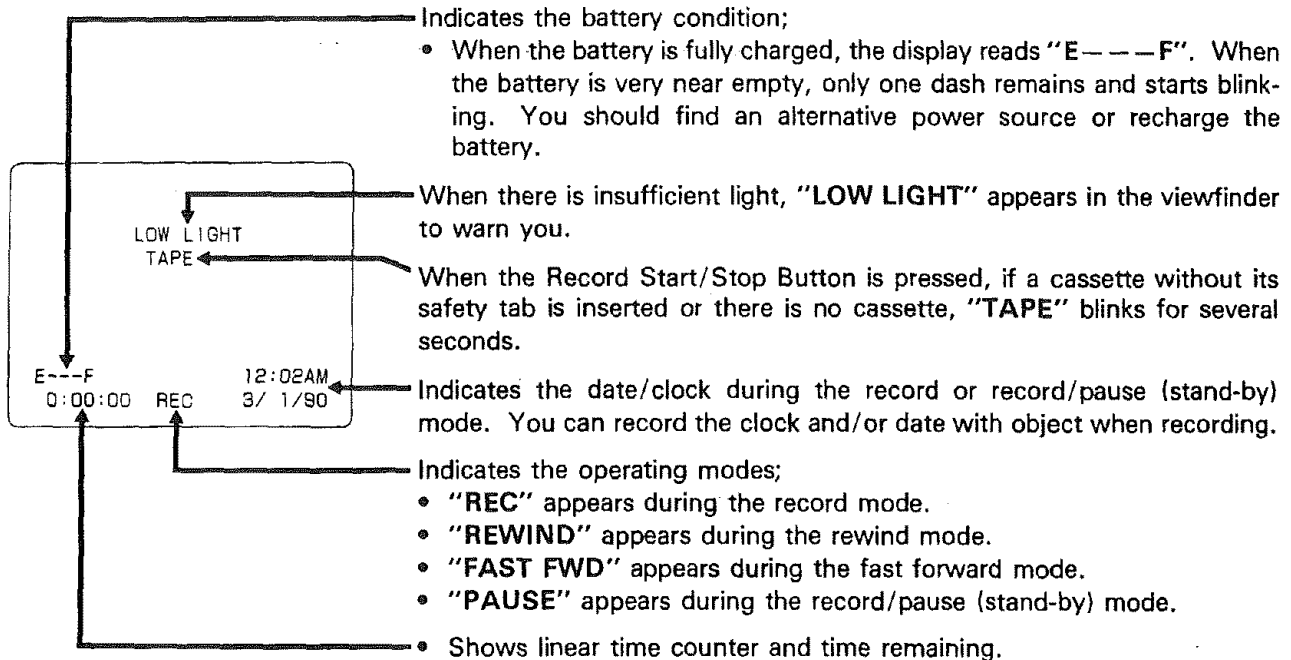

"MIC" Jack

Connect an external microphone (Not supplied) here to record sound from the external microphone.

NOTE: Connecting an external microphone automatically switches off the built-in microphone.

Power Zoom Switch

This switch performs zooming electrically.

"W": Picture becomes wider gradually.

"T": Picture becomes telescopic gradually.

Record Start/Stop Button

This Button is used to control the Camera/Recorder. When this Button is pressed with the Camera/Recorder set to the recording mode, the tape runs to start recording. "REC" appears in the viewfinder.

When this Button is pressed again, "PAUSE" appears instead of "REC" and the tape stops and the Camera/Recorder enters the record/pause (stand-by) mode.

Lens Cap Tab

Place the lens cap on this tab when you are ready to record a scene. The tab also prevents the lens cap from swinging around on its cord.

Hand Strap

Adjust to best fit to your hand.

AUTO FOCUS

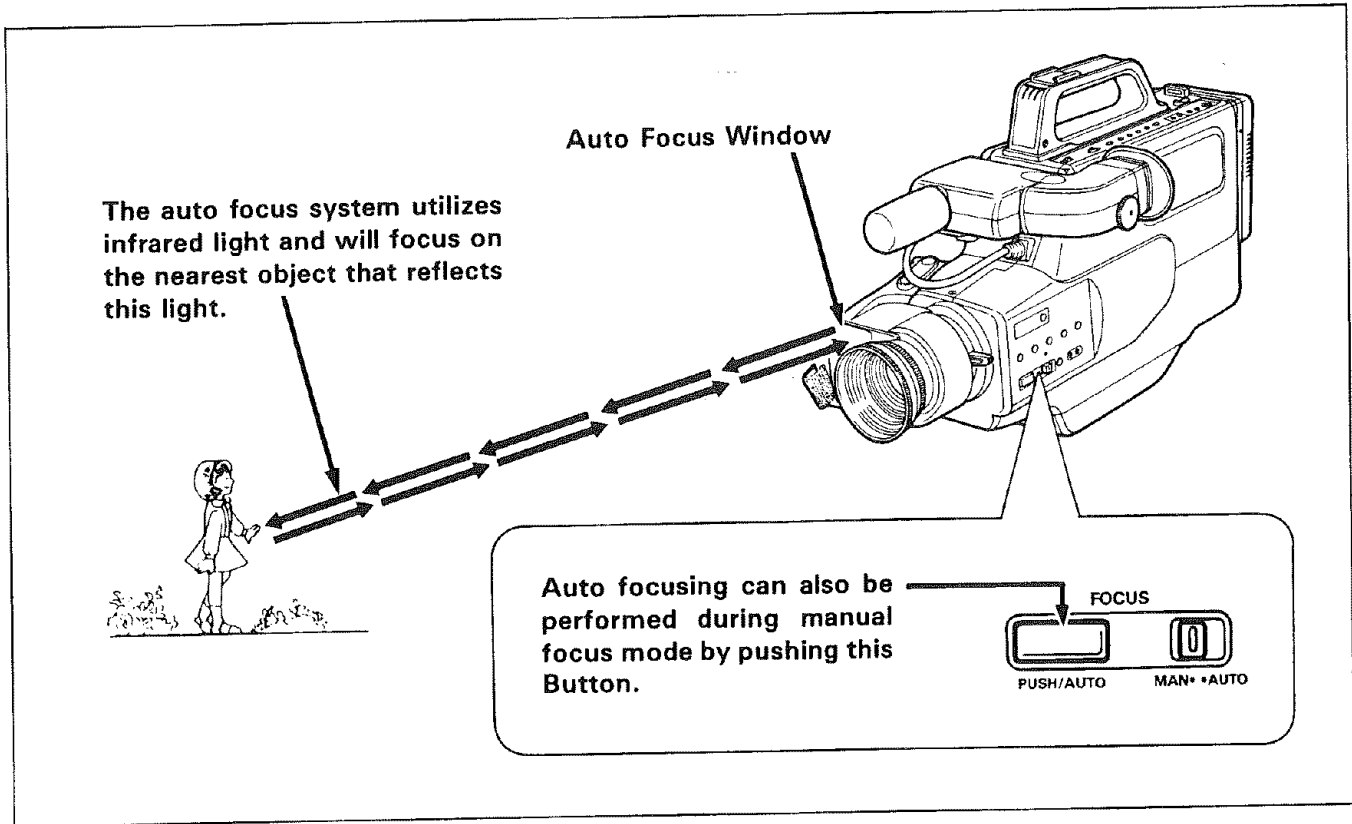

With the "FOCUS AUTO/MAN" Switch set to "AUTO" position, ordinary objects are automatically in optimum focus.

■ OBJECTS HARD TO AUTO FOCUS

The distance between the Auto Focus Window and the object is measured, and the Focus Ring is automatically turned for focusing. However, with the scenes such as shown below, the auto focusing may not operate properly, and manual focus must be performed. See next page.

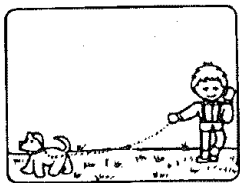

1. Object is not in the center.

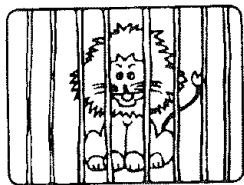

2. Object in far and near positions at the same time.

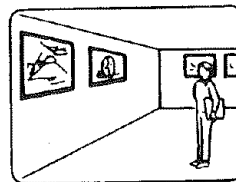

3. Object with continuous variation from far to near positions.

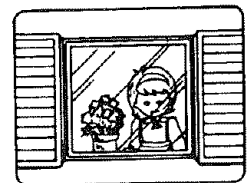

4. Object behind glass.

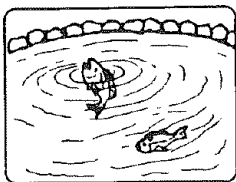

5. Black object or water which does not reflect infrared light.



6. Object always moving such as a crowd.



7. Object in the snow or fog.

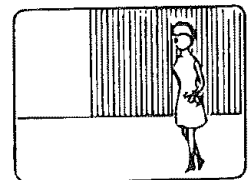

8. Objects with equal pitches.

■ MANUAL FOCUSING

1. Set "FOCUS AUTO/MAN" Switch to "MAN" position.
2. Zoom in on the object by pressing the Power Zoom Switch on the "T" side.

NOTE: See page 21 for "POWER ZOOM".

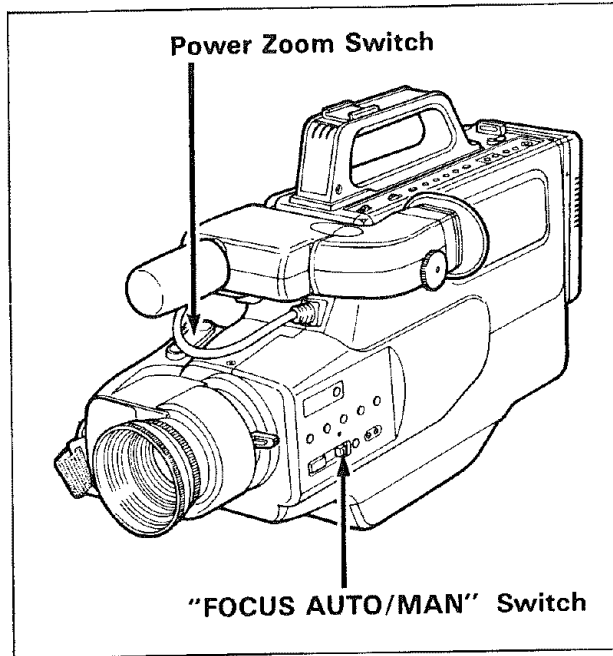

3. Focus on the object by turning the Focus Ring.
- NOTE: If focusing is performed without zooming up first, the picture may become out of focus when the zoom-in is done during actual picture taking.
4. Then, zoom out from the object as desired.

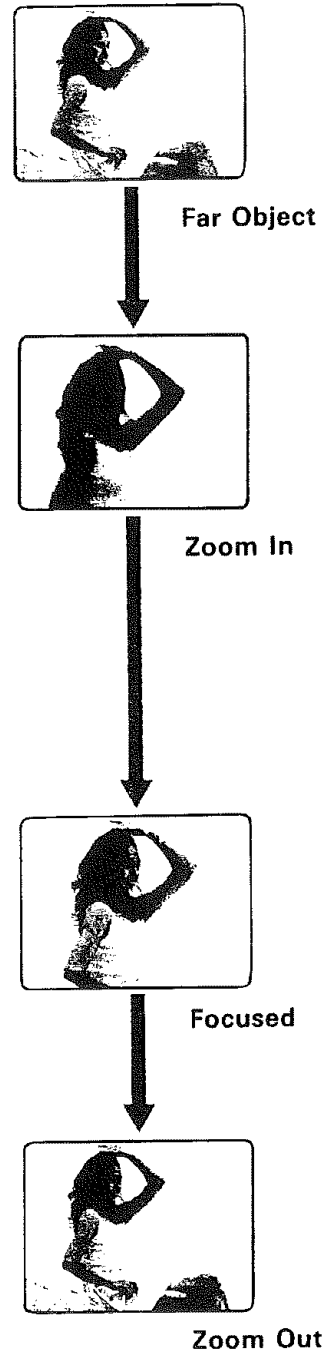
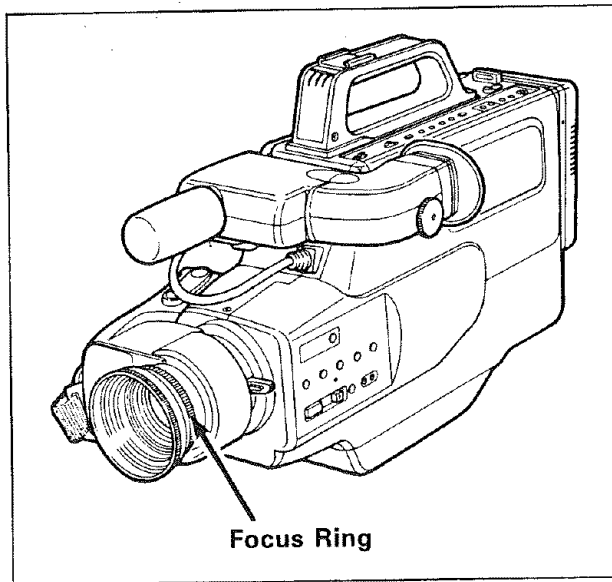

NOTES:

- The Auto focusing will not function if the lens is left in macro mode.
- Auto-Focus will not operate properly when the Telephoto or Wide-angle lens is attached to the Video Camera/Recorder.

POWER ZOOM

- Press Power Zoom Switch on the "W" side, and the picture gradually widens.



- Press Power Zoom Switch on the "T" side, and the picture gradually becomes telescopic.

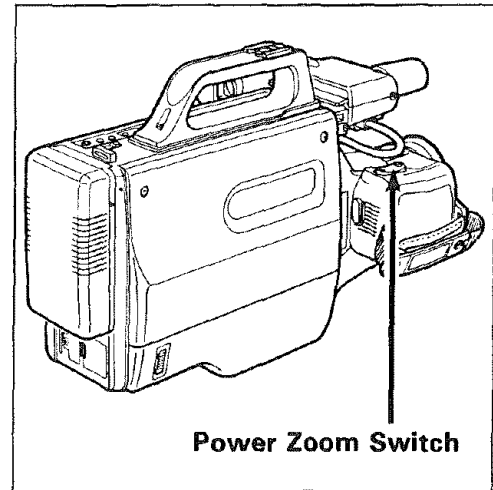

MACRO LENS

Allows you to shoot objects as close as 1 cm from the lens tip.

1. Set "FOCUS AUTO/MAN" Switch to "MAN" position.
2. Turn the Zoom Lever to "MACRO" while pressing "MACRO" Button.
3. Turn the Zoom Ring within the "MACRO" range (green line on the zoom ring) for focusing.

NOTE: Be sure to release the macro mode after using. If you fail to release the macro mode before returning to normal shooting, the pictures will be out of focus and Auto-Focus will not operate.

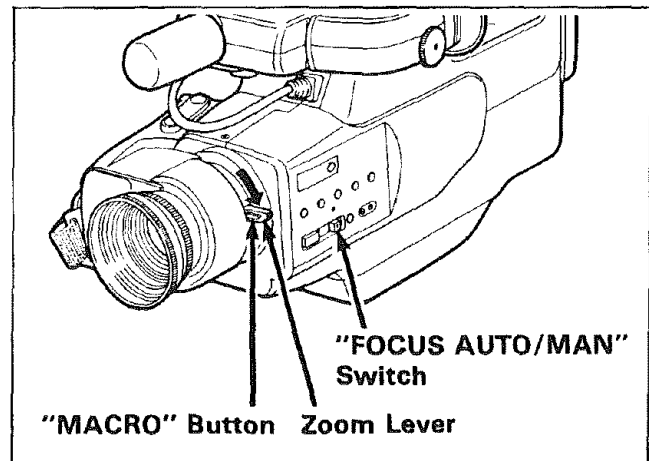

INSTANT REVIEW

1. In record/pause (stand-by) mode, press "REVIEW" Button, and the recorded scene of the last few seconds is played back in the reverse direction and then played back in the forward direction.

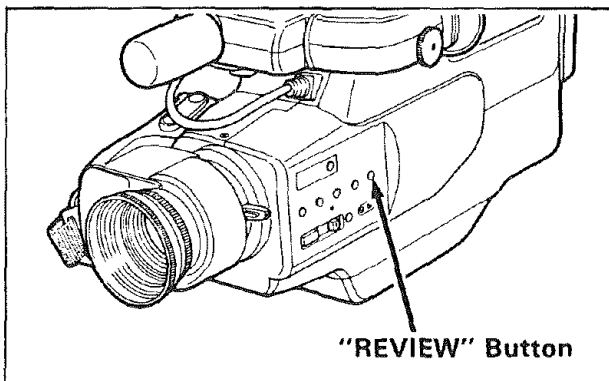

2. When the tape reaches the end of the scene you have just recorded, the Video Camera/Recorder returns to the record/pause (stand-by) mode. Recording starts again when the Record Start/Stop Button is pressed again.

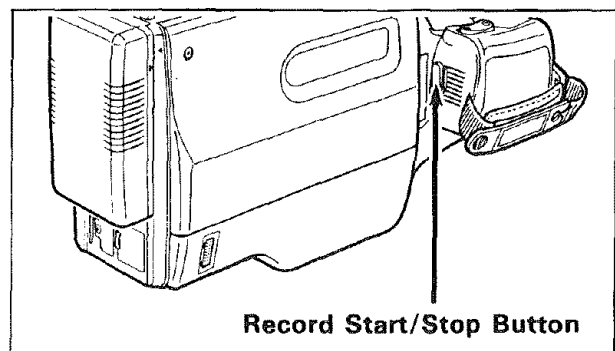

VARIABLE SHUTTER SPEED

Use this feature to shoot tennis and golf shots that contain rapid movement. You can replay the still pictures at the crucial moments without any fluctuations.

Normally the shutter speed is 1/60 seconds. The speed can be changed up to 1/500 seconds or 1/1000 seconds.

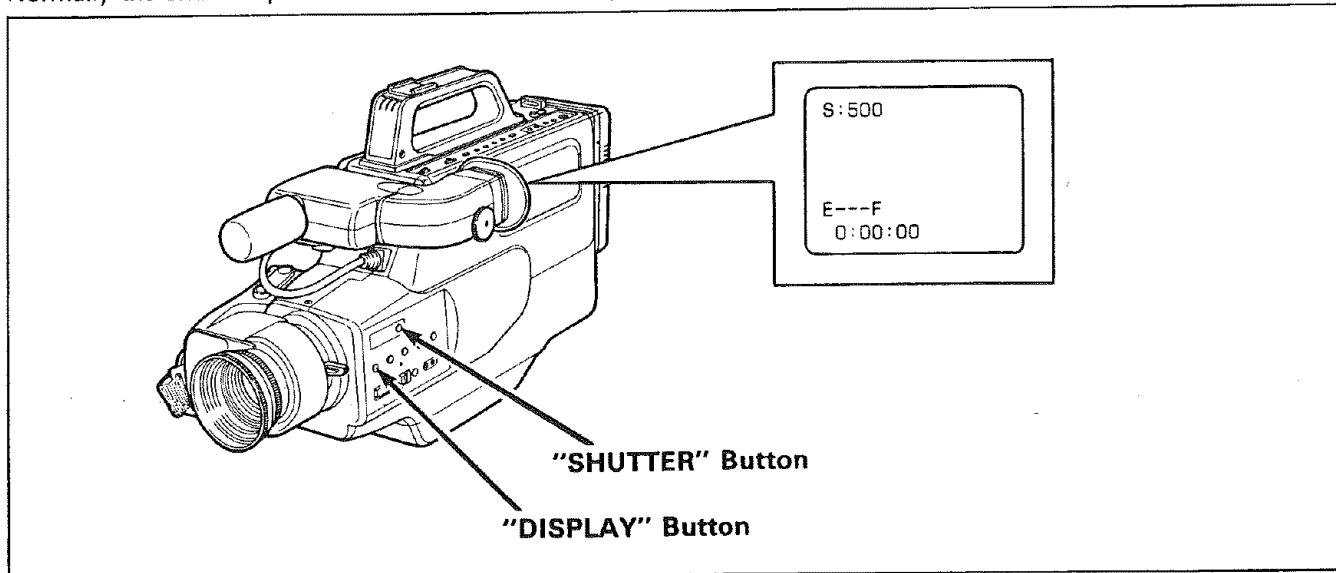

1. In record/pause (stand-by) or record mode, press **"DISPLAY"** Button to display battery level indicator in the viewfinder.

2. Press **"SHUTTER"** Button once or twice. The shutter speed will change 1/500 or 1/1000 and then back to 1/60 seconds. The shutter speed is displayed in the viewfinder.

For example, the speed is 1/1000 seconds, **"S:1000"** will be displayed.

NOTE: When the shutter speed is 1/60 seconds, **"S:60"** will not be displayed in the viewfinder.

3. Press Record Start/Stop or **"PAUSE/REC"** Button to start recording.

NOTES:

- After use, press **"SHUTTER"** Button so that display of 1/500 or 1/1000 will disappear.
- When shooting at the 1/1000 speed, more light is required because the pictures become darker than the normal shooting at 1/60 speed. When there is insufficient light, **"LOW LIGHT"** appears in the viewfinder to warn you.
- When a tape that was recorded using the high speed shutter feature is played back, scenes changes will not be seen as a smooth motion.
- When the camera is pointed at an object that is moving rapidly, it may not be focused in the auto focus mode. In this case, focus manually.
- When you are recording with the 1/500 seconds shutter speed or play back the tape on which recording was made with this shutter speed, the top and bottom of the picture may be lost on some TVs connected to the camera/recorder, but this does not indicate a fault.

AUTO IRIS

This Camera/Recorder is provided with an auto iris mechanism which automatically adjusts the lens aperture in accordance with the incident light. When the object is dark, the iris opens automatically, and it closes when the object is bright. When the power is switched off, the iris is automatically set to the fully closed position.

RECORDING TV PROGRAM

If your TV or VCR has an audio/video out jacks, you can record the TV program with Camera/Recorder.

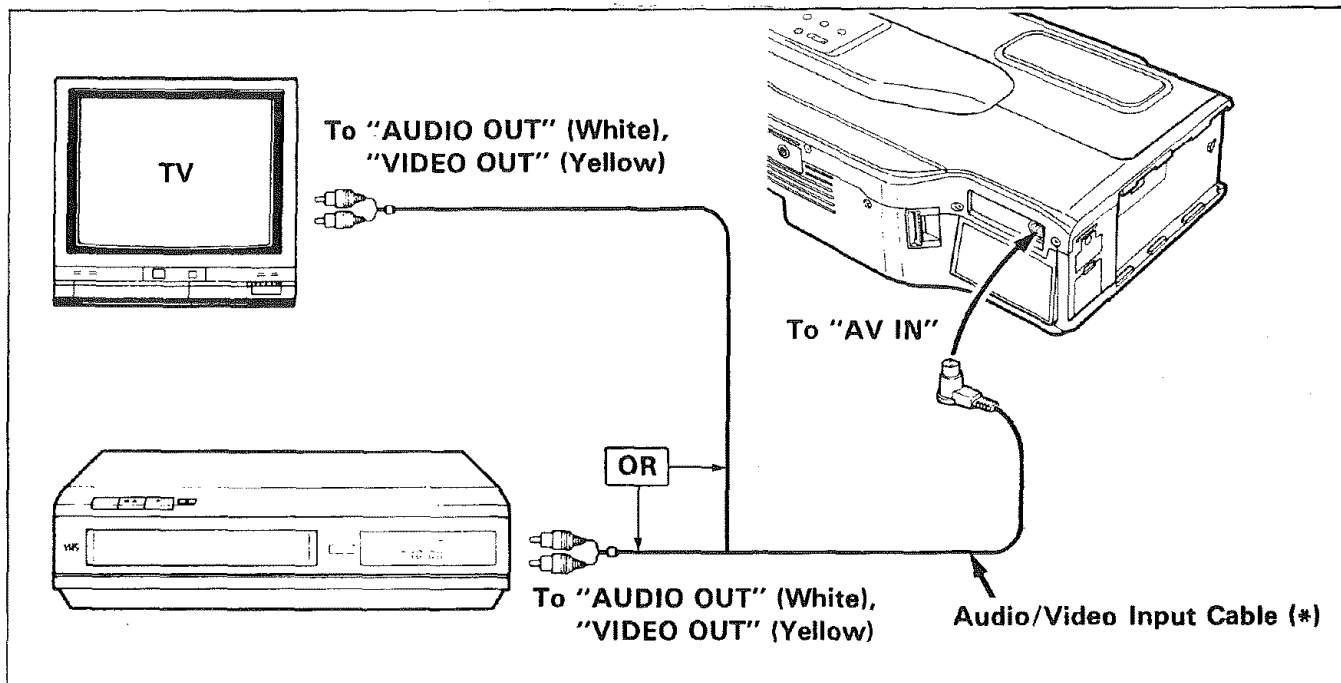

1. Connect the Audio/Video Input Cable to "AUDIO OUT" and "VIDEO OUT" of your TV or VCR.
2. Connect the other end to "AV IN" of Camera/Recorder.
3. Slide "VCR/CAM" Select Switch to "CAM" position.
4. Insert the cassette.
NOTE: Power source must be connected to the Camera/Recorder.
5. Turn on power of Camera/Recorder.
6. Turn on your TV or VCR and tune it to the channel you wish to record.
7. Press Record Start/Stop or "PAUSE/REC" Button to start recording. You are now recording the TV program.
8. Press Record Start/Stop or "PAUSE/REC" Button to stop recording.
9. After recording turn off power of Camera/Recorder and then press "EJECT" Button to remove the cassette.

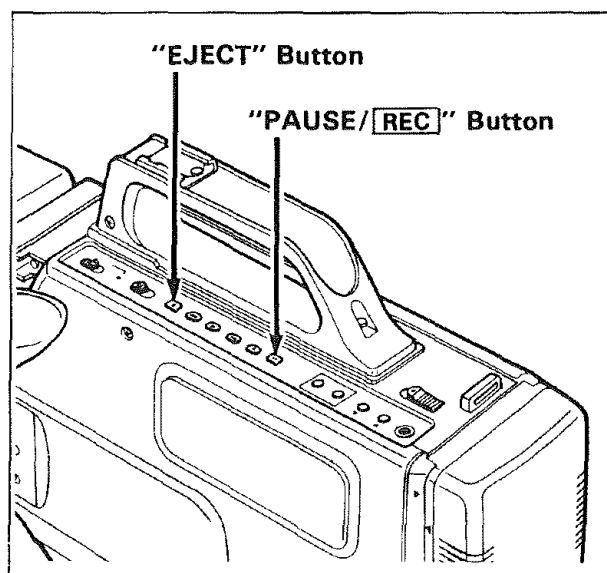
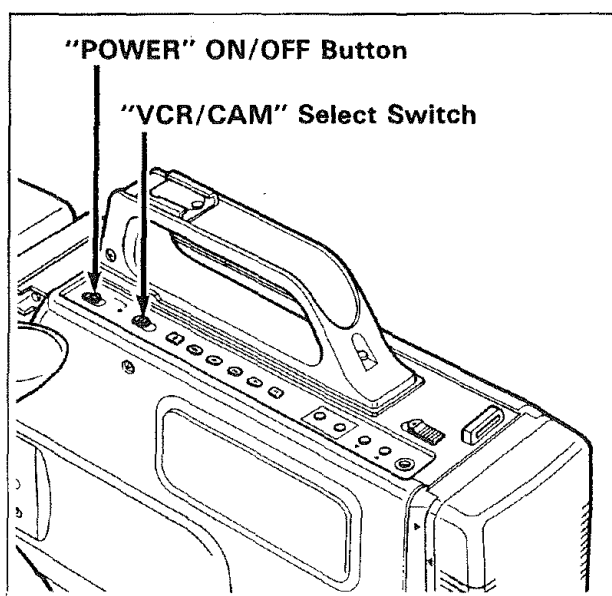

(*) Optional — not supplied.
See page 2 for ordering information.

AUDIO DUBBING

The audio dubbing feature lets you record new audio (sound) on a previous recorded tape without erasing the original video (picture).

When you audio dub a tape, the previous audio is erased and replaced with new sound.

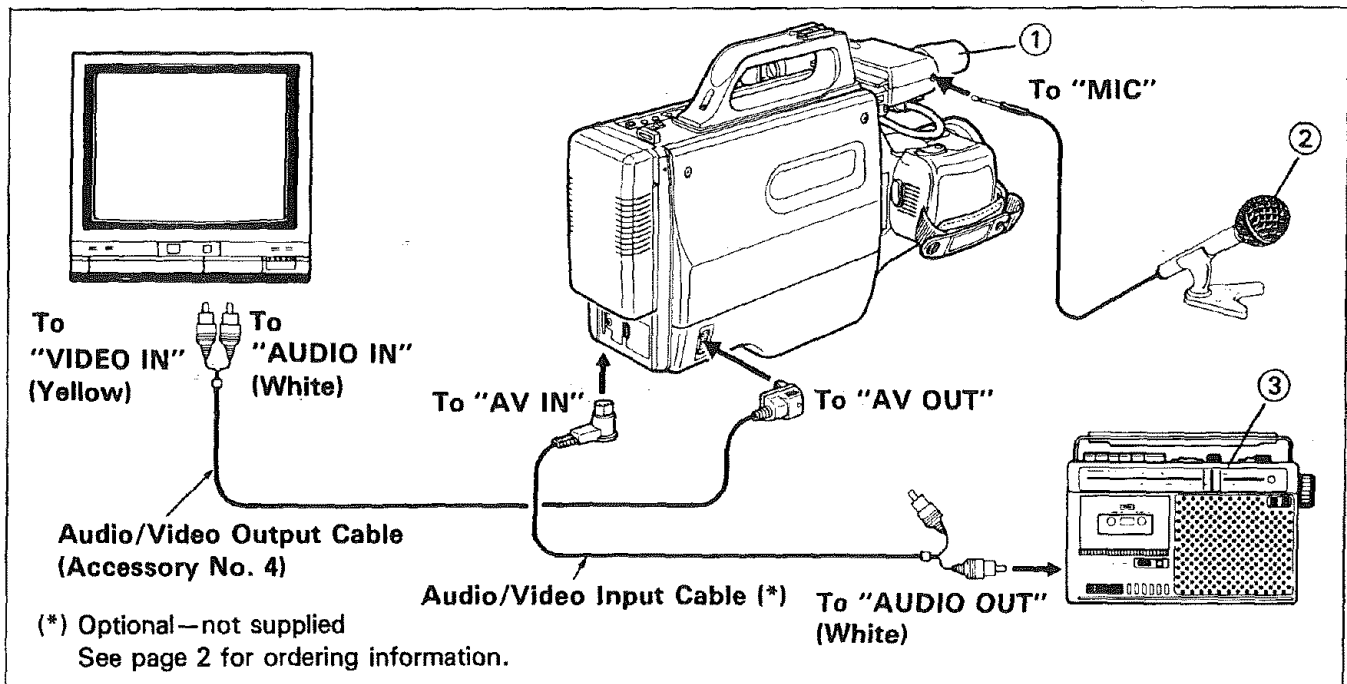

- NOTES:**
- Sound from the built-in microphone, external microphone and the AV IN jack can be dubbed.
 - Do not connect the "AV IN" jack when dubbing audio from the external microphone or built-in microphone. Connecting an external microphone also switches off the built-in microphone automatically.

1. Insert a recorded tape.
Be sure that the record safety tab is not missing.
2. Set "VCR/CAM" Select Switch to "VCR".
3. Play the tape and press "PAUSE/REC" Button where you want to dub audio.
 - The Camera/Recorder enters the still play mode.
4. Press "AUDIO DUB" and "PLAY" Buttons at the same time.
 - "A.DUB" appears in the viewfinder.
5. Press "PAUSE/REC" Button to start audio dubbing.
6. Press "STOP" Button to stop audio dubbing.

NOTE: If counter memory "M" appears in the viewfinder, the tape stops automatically at the reading of "0:00:00" and audio dubbing stops.

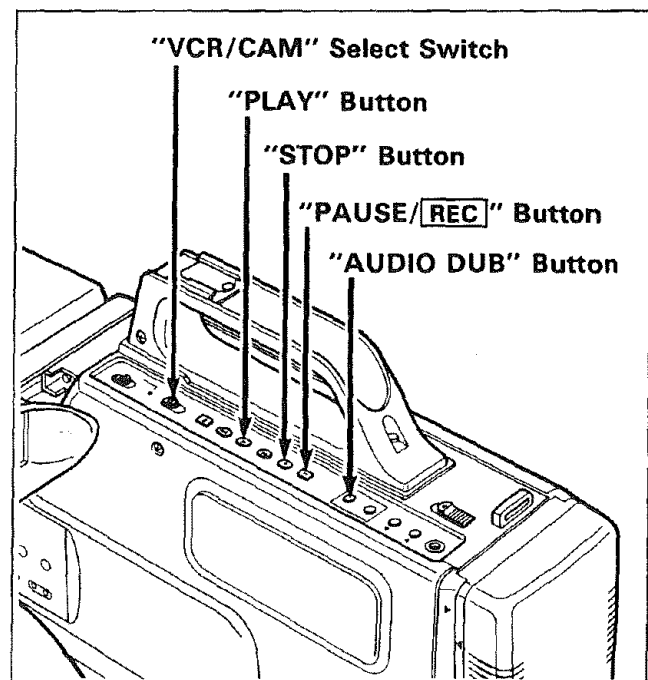

VIDEO DUBBING

The video dubbing feature lets you record new video (pictures) on a previously recorded tape without erasing the original audio (sound).

When you video dub a tape, the previous video is erased and replaced with the new pictures. The replacement video can be the picture taken by the camera or from a video source connected to "AV IN" on the Camera/Recorder.

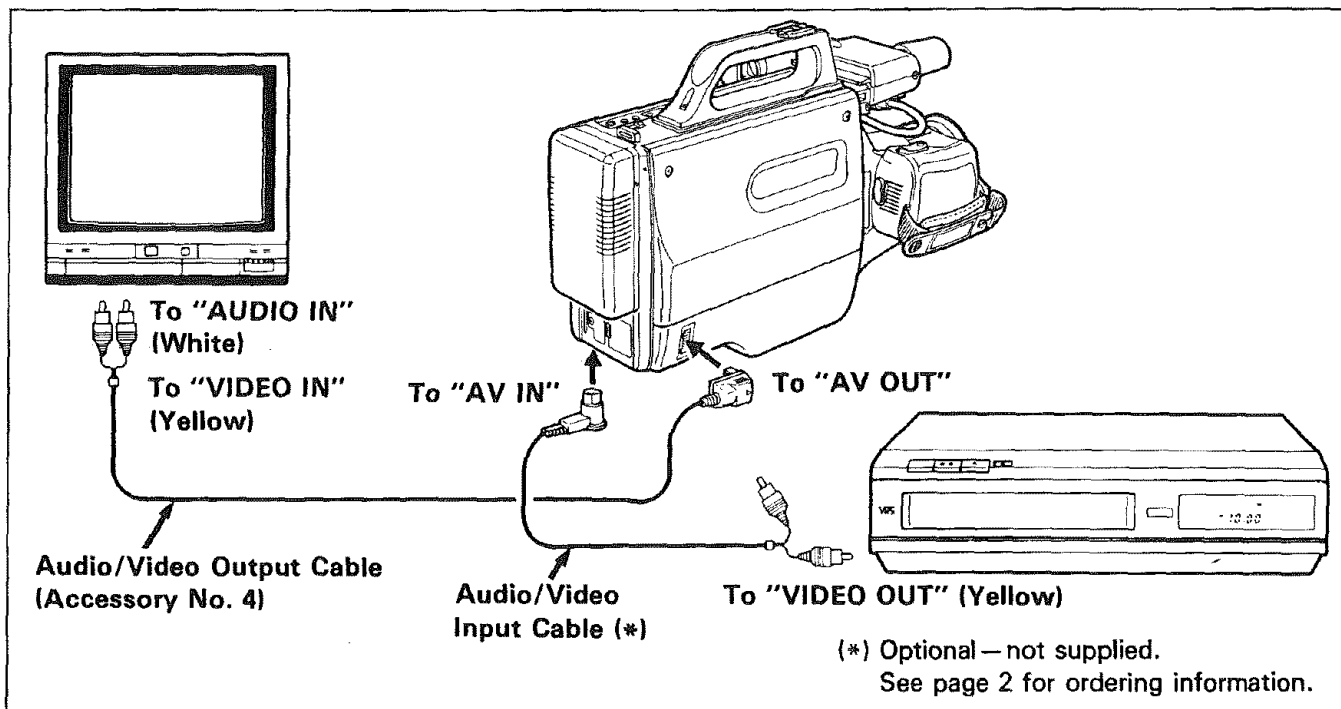

1. Insert a recorded tape.

Be sure that the record safety tab is not missing.

2. Set "VCR/CAM" Select Switch to "VCR".

3. Press "PLAY" Button and then "REW" or "F.FWD" Button to search to the approximate position of the tape on which you want to dub a picture.

4. Press "PLAY" Button again to search the exact position where you wish to stop dubbing and then press "PAUSE/REC" Button at the exact position.

5. Press "DISPLAY" Button so linear time counter appears and then press "RESET/T-160" Button to set the counter reading to "0:00:00".

6. Press "MEMORY" Button so counter memory "M" appears.

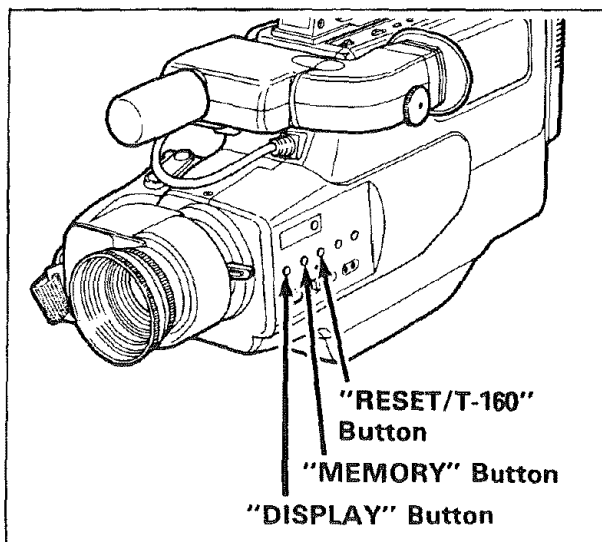
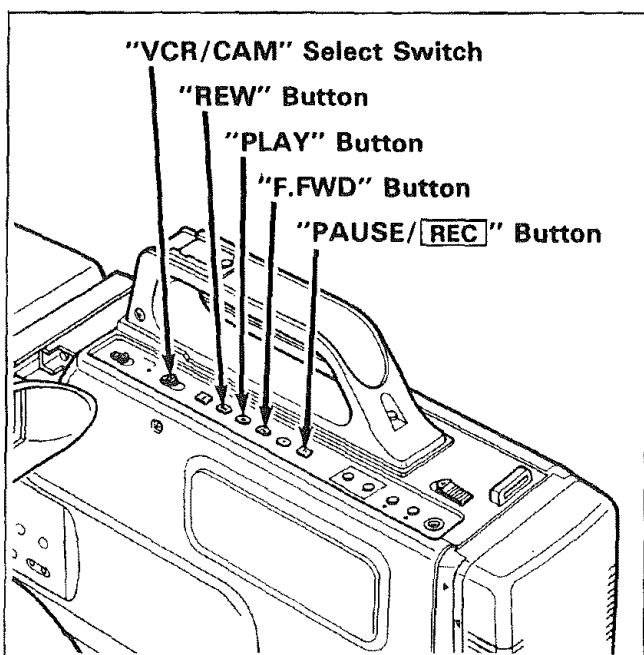

7. Press "REW" Button to rewind the tape to the approximate position from which you want to start dubbing.

8. Press "PLAY" Button, and when the exact position to start dubbing is reached, press "PAUSE/REC" Button.

9. Press "VIDEO DUB" and "PLAY" Buttons simultaneously. "V.DUB" is displayed in the viewfinder, and at the same time the picture to be dubbed appears.

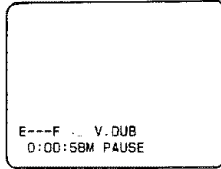

10. Press "PAUSE/REC" Button.
Video dubbing will start and will stop when the counter reads "0:00:00".

NOTE: You can also dub both the video and audio simultaneously if desired. To do so, press "AUDIO DUB" and "PLAY" Buttons first, then press "VIDEO DUB" and "PLAY" Buttons in step 9 above.

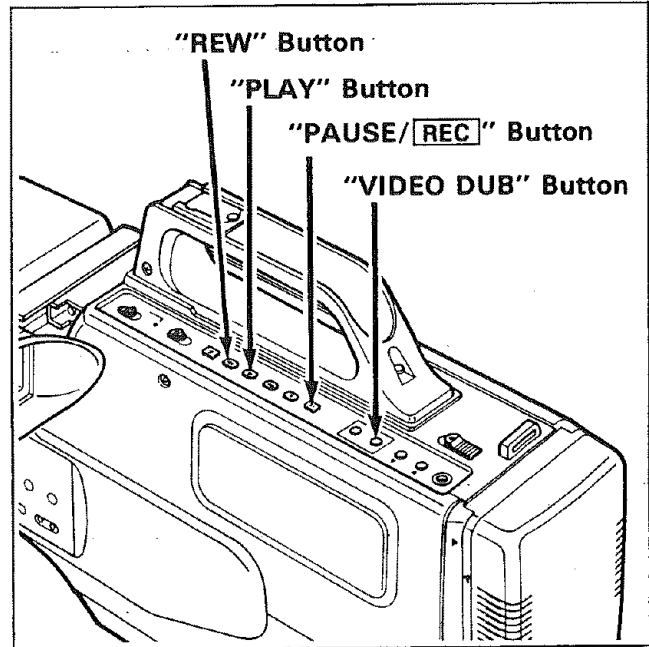

INDEX SIGNAL RECORDING

Each time you begin recording (after the Camera/Recorder has been turned off at least four hours), the Camera/Recorder will automatically record an index mark at the beginning of the new recording.

Later, when you play back the indexed tape in a VCR that has a compatible indexing feature called "VHS Index Search System", the invisible marks can be located automatically. See your VCR's owner's manual for index playback instructions.

The word "INDEX" will appear briefly in the viewfinder to let you know the Camera/Recorder is recording an index mark.

NOTES:

- The Camera/Recorder automatically records an index mark only once—at the start of each day's recording session (or whenever it hasn't been used for more than four hours).
- It does not automatically record index marks each time you stop and start recording—only the first time you turn on the Camera/Recorder and start recording.

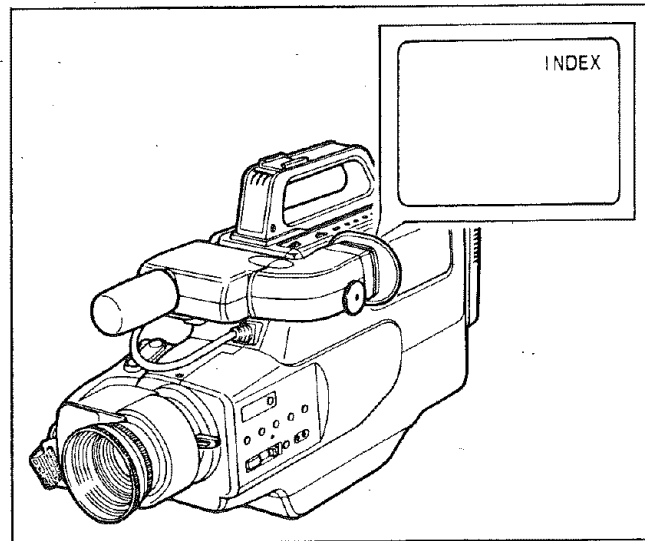

DATE/CLOCK SETTING

The date and clock can be recorded on your tapes to act as a handy reference when viewing them at a later time. Use the following procedure to set up this display for the current date and time.

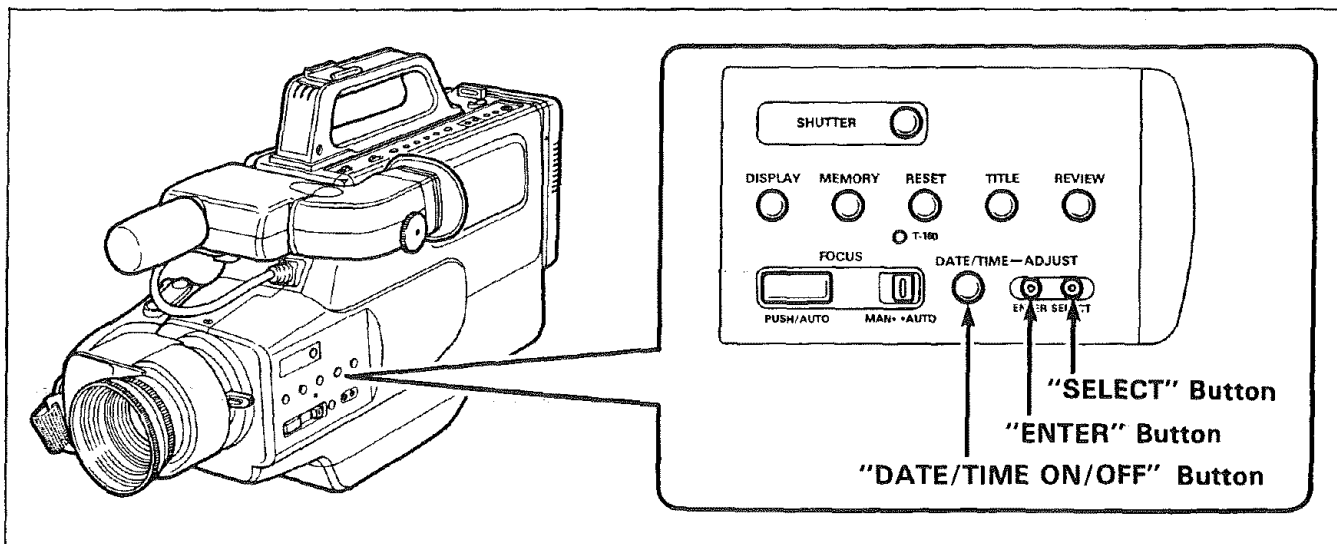

1. Load the camera/recorder's date/clock battery as described on page 8.
2. Turn on power of Camera/Recorder.
3. Set "VCR/CAM" Select Switch to "CAM".
4. Press "DATE/TIME ON/OFF" Button.
Date and time appear in the viewfinder and "1" flashes.

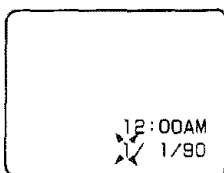

5. Press "SELECT" Button to select correct month. Hold Button down to advance rapidly. When the correct month appears, press "ENTER" Button.

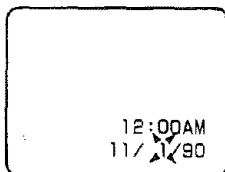

6. Press "SELECT" Button to select correct date. Hold Button down to advance rapidly. When the correct date appears, press "ENTER" Button.

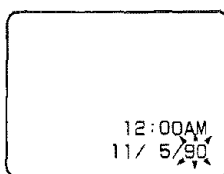

7. Press "SELECT" Button to select year, and then press "ENTER" Button.

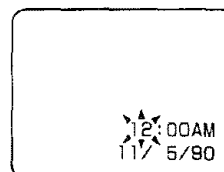

8. Press "SELECT" Button as many times as may be required to select correct hour, and then press "ENTER" Button.

9. Repeat step 8 to select minute and AM/PM.

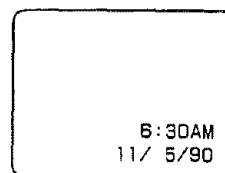

10. After setting AM or PM, press "ENTER" Button again to erase the flashing cursor and start the internal clock.

NOTES:

- To correct date/clock information during programming or after starting the date/clock, press "ENTER" Button until the incorrect digit is flashing. Then use "SELECT" Button to enter the correct digit.
- The date/clock graphics will be recorded whenever they appear in the viewfinder. To display date and clock together, press "DATE/TIME ON/OFF". To display date only, press "DATE/TIME ON/OFF" again. Pressing "DATE/TIME ON/OFF" a third time removes both graphics.

ATTACHING THE DC CAMERA LIGHT

Use the DC camera light if you wish to shoot objects in dark places.

NOTES:

- The DC camera light operates when a battery pack or AC Adaptor/Charger is attached to the camera/recorder. It does not operate with the car battery cord.
- The power consumption of the DC camera light is much more than that of the camera/recorder. Therefore, if the camera light turns on when a fully charged battery pack is attached, the operation time by the battery becomes less than half.
- When the camera/recorder is turned on, current always flows to the terminal with which the DC camera light is in contact. Never touch the terminal with your fingers in this condition.

1. Make sure that a fully charged battery pack or AC Adaptor/Charger is attached.
2. Check that the camera/recorder is turned off.

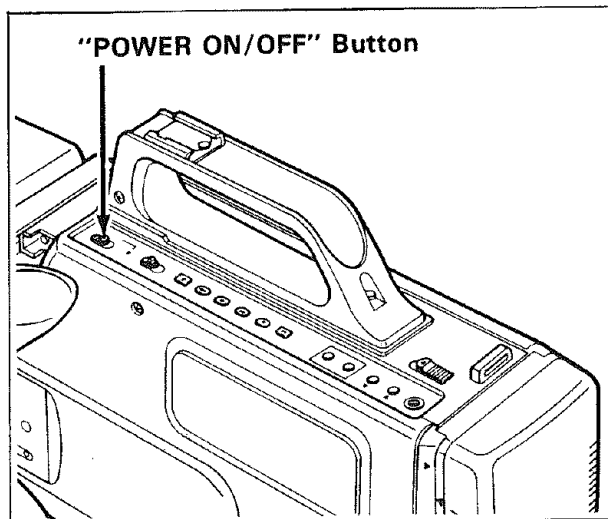

3. Attach the DC camera light to the accessory shoe.

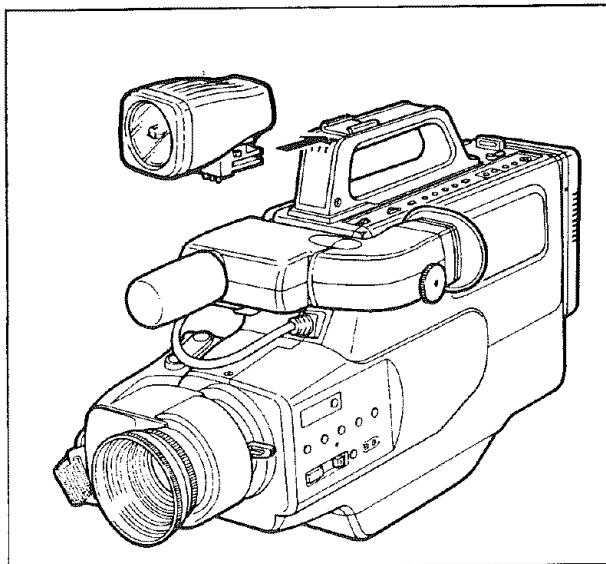

4. Turn on power of the camera/recorder and then press the "POWER" Button of the DC camera light when required.

NOTE: Turn on the camera light only when you need it. Otherwise the operation time of the battery pack becomes shorter because the power consumption of the camera light is high.

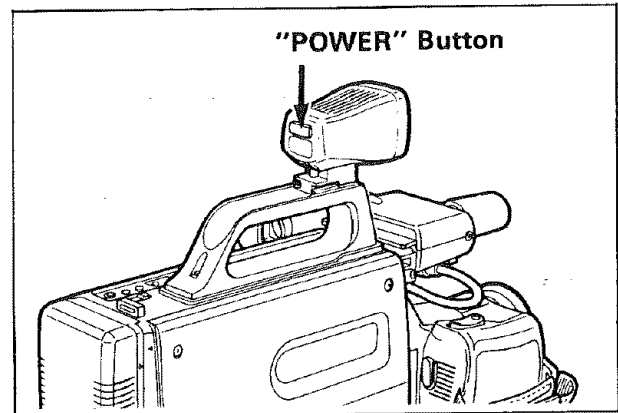

5. To remove the camera light, slide the camera light to the direction of arrow while pressing the lock button.

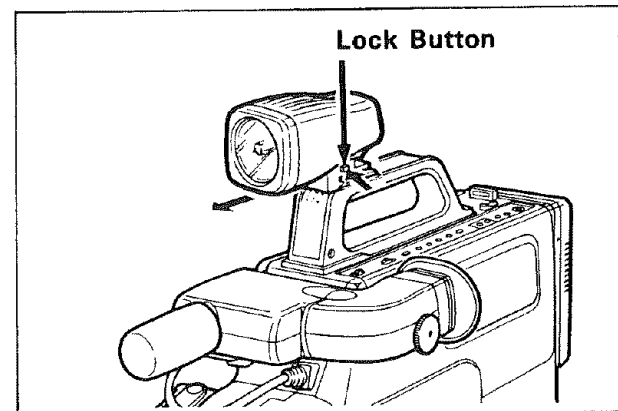

NOTES:

- During operation and/or after use of the camera light, the front surface and lamp of the camera light will be very hot. To avoid burns, do not touch them with your hand.
- When the camera light is on, do not allow water to drop on the light.
- When the camera light is on, avoid subjecting the camera light to impacts or sharp vibrations.
- Do not allow the cooling vents to become blocked. Also, do not cover the camera light with paper or other objects, since the air flow will be interrupted, resulting in possible overheating hazard.
- Never use the camera light in the vicinity of explosive or highly inflammable materials.
- When storing the camera light in the camera case following use, be sure to allow it sufficient time to fully cool down before placing it in the case.
- Replace only with 57-53985 bulb (optional accessory), to reduce the risk of fire.

TITLE MAKING

You can easily create and record personalized titles on your videos with the Camera/Recorder's built-in titler. The titler will store 2 different title pages in memory. Once a title is stored, it can be displayed and recorded at any time. Each title page can contain one line of 16 characters each. The character contains 47 different characters for creating titles.

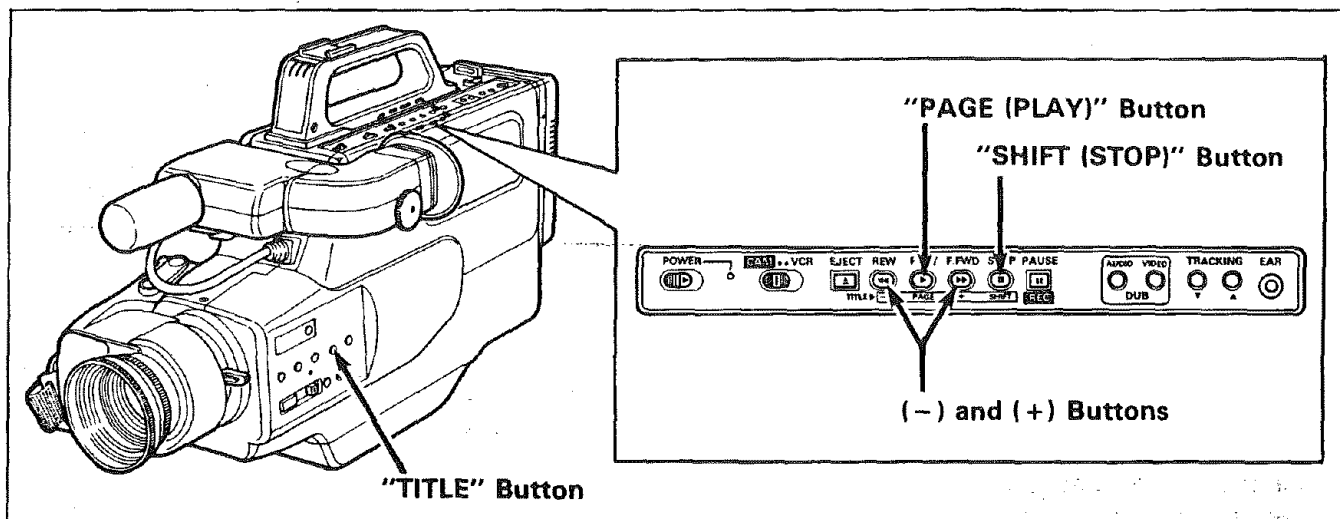

■ Creating a Title

1. Attach a power source to the Camera/Recorder and press "POWER" ON/OFF Button on.
NOTE: "VCR/CAM" Select Switch may be "VCR" or "CAM".
2. Press "TITLE" Button. The flashing cursor will appear in the viewfinder.

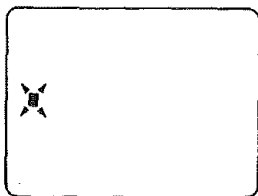

3. Press "SHIFT" Button repeatedly to move the flashing cursor to the place you want to begin your title.
4. Select the first character for your title by pressing the (-) or (+) Button repeatedly until the desired character appears.

NOTE: Each title can contain up to one line of 16 characters each. A chart showing the characters contained in the registers is located below.

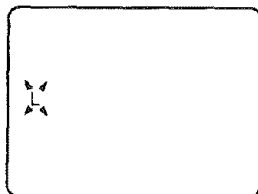

5. After you have selected the first character, press "SHIFT" Button to move the flashing cursor to the place you want the next character.

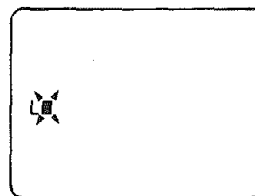

6. Repeat steps 4 and 5 until you have completed the title.

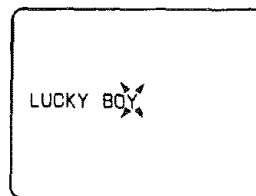

NOTE: Character may flash, however it will be recorded correctly without flashing.

7. After completing your title, press "PAGE" Button and create the title on another title page.
8. After creating the title, press "TITLE" Button to remove the title graphics from the viewfinder. Now title graphics is stored in memory.

■ Chart of Characters available by using the CHARACTER control

A	B	C	D	E	F	G	H	I	J	K	L	M	N	O	P	Q	R
S	T	U	V	W	X	Y	Z	0	1	2	3	4	5	6	7	8	9
?	'	.	/	,	-	;	:	<	>	!							

■ Correcting Errors During Programming

1. Press "SHIFT" Button repeatedly until the character to be corrected flashes.
2. Press either "-" or "+" Button until the correct character appears.

NOTE: The corrected character may flash, however it will be recorded correctly without flashing.

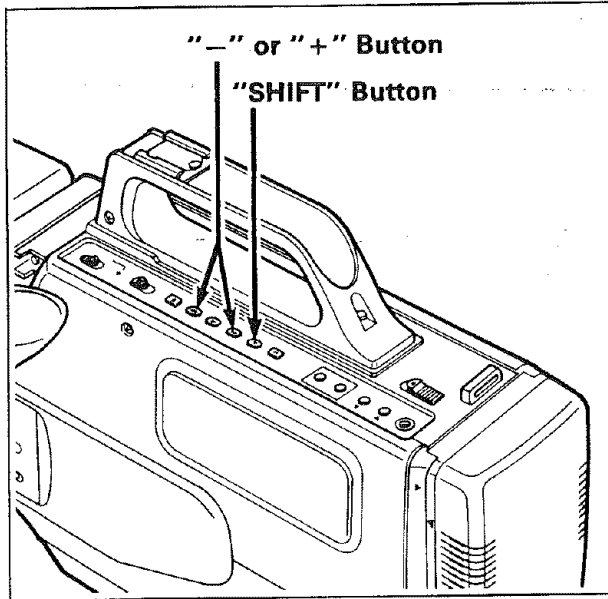

■ Recording Titles on Another VCR while playing a Tape Back with the Camera/Recorder

1. Connect the Camera/Recorder and VCR. (See page 38.)
2. Select the title you wish to record (from page 1 or page 2).
The last title selected will appear first. Press "TITLE" Button to turn title off.
3. Set the VCR in the recording mode and Camera/Recorder in the playback mode.
4. Press "TITLE" Button when you see the scene where you want to record the title.
5. Press "TITLE" Button to erase the display from the viewfinder.

■ Recording Titles on a Tape in the Camera/Recorder

1. Press "POWER" ON/OFF Button on and set "VCR/CAM" Select Switch to "VCR".
2. Locate the position on the tape that you wish to record the title.
3. Set "VCR/CAM" Select Switch to "CAM".
4. Press "TITLE" Button to display the title graphics.
5. Press "PAGE" Button until the title you wish to record appears in the viewfinder.
6. Press Record Start/Stop Button or "PAUSE/REC" Button to start the title recording.
7. Press "TITLE" Button to remove the title graphics from the viewfinder.
The Camera/Recorder will now record as normal.

EYEPIECE ADJUSTMENT

To use the electronic viewfinder without eyeglasses on, adjust the Diopter Control for optimum focus.

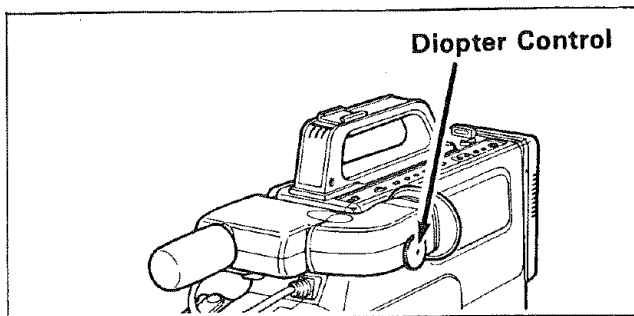

PRODUCING BEST COLOR PROGRAM

LIGHTING — Lighting should be uniform from the top —

Essential points on lighting people

1. A key light should be provided at the upper left in front of the person.
2. A weaker base light (spot) should be provided at the upper right and balanced with the key light. (Adjusting so that the left:right ratio is 2 : 1.5 by moving the lights backwards and forwards.)
3. Use one more light behind the subject. This emphasizes the person's head and shoulders and prevents the subject from being lost in the background.

Caution: Do not place lighting equipment near the Video Camera/Recorder as heat from the lighting equipment can cause the Video Camera/Recorder to malfunction.

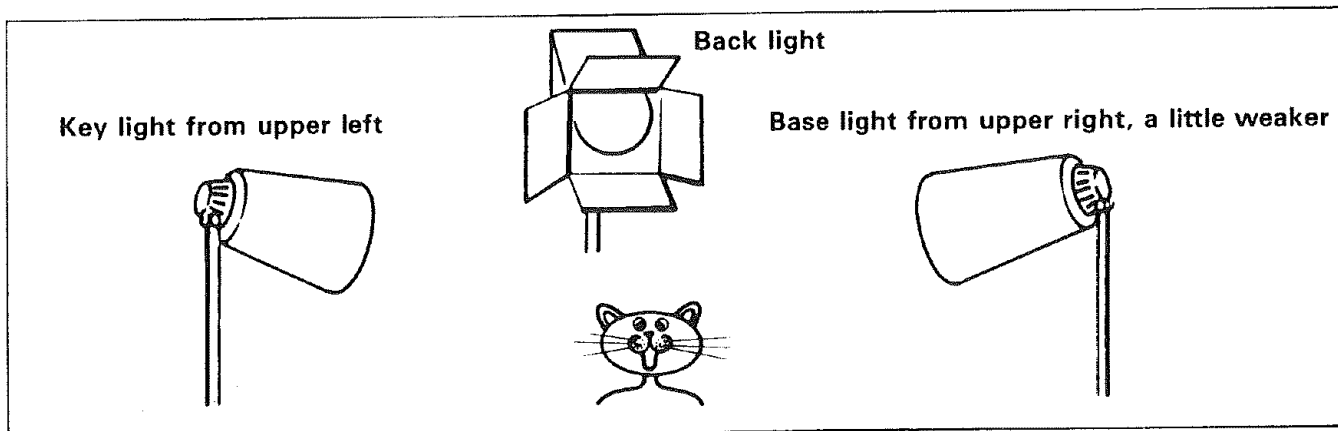

Approximate brightness value (for reference only)

Unit: lux

Illumination of 500 to 100,000 lux is required for clearest pictures, though the camera can shoot an object in illumination of 3 to 100,000 lux. Increase illumination when object illumination is less than 500 lux. Install an ND (Neutral Density) filter (46 mm dia. and 0.75 mm pitch) on the lens if an object's illumination exceeds 100,000 lux.

10	<ul style="list-style-type: none"> • Candle at 20 cm (10—15) • Cigarette lighter at 30 cm (15) • During intermission at a movie theater (15—35)
100	<ul style="list-style-type: none"> • Workshop in a machinery factory (150—200) • Arcade at night (150—200) • Flashlight at 1 meter (250) • Study desk with fluorescent lighting (400) • Office with fluorescent lighting (400—500) • Library reading room (400—500) • Bowling alley (500) • Sales floor of a department store (500—700)
1,000	<ul style="list-style-type: none"> • Clear day one hour before sunset (1,000) • Cloudy day one hour after sunrise (2,000)
10,000	<ul style="list-style-type: none"> • Cloudy day at 10 AM (25,000) • Cloudy day at noon (32,000) • Clear day at 3 PM (35,000) • Clear day at 10 AM (65,000)
100,000	<ul style="list-style-type: none"> • Clear day at noon (100,000)

VIEWING THE PICTURE PLAYED BACK ON YOUR TV

To play back a tape recorded on your Video Camera/Recorder and view it on your TV receiver, you must connect the Video Camera/Recorder to the TV receiver using either Audio/Video Output-Cable (Accessory No. 4) or RF Converter Unit (Optional Accessory).

You may also play back the tape recorded by your Video Camera/Recorder on any other VHS video cassette recorder. The Video Camera/Recorder records and plays back in VHS standard speed (SP). A tape recorded in long play (LP) or extra long play (EP) cannot be played back on this Video Camera/Recorder.

Example 1: If your TV is a regular TV,

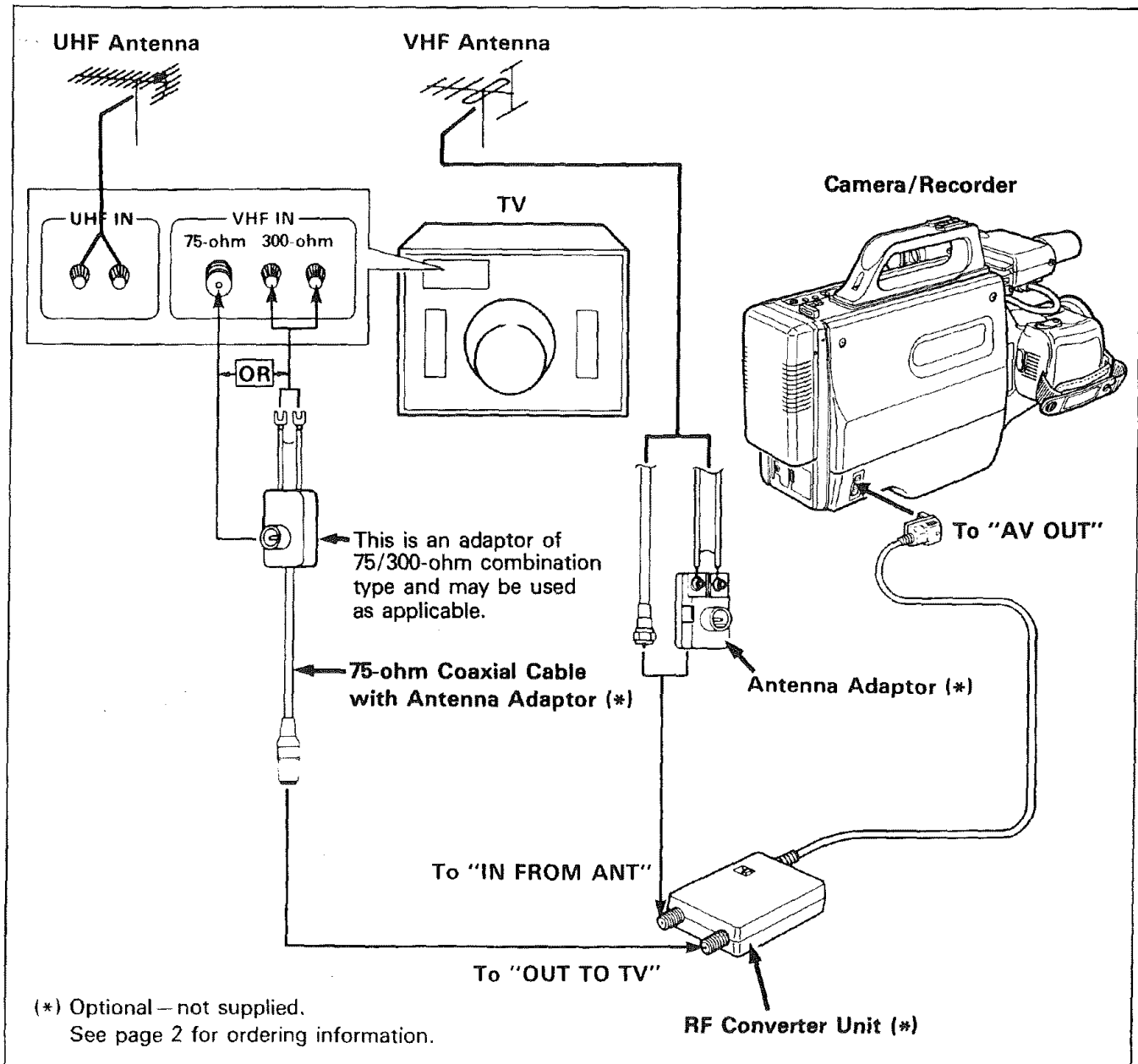

1. Disconnect the VHF antenna leads from the rear of the TV receiver.

NOTE: Leave the UHF antenna leads connected to the TV.

2. Connect the VHF antenna lead to "IN FROM ANT" on the RF Converter Unit. If the cable is round (75-ohm), it will connect directly to the "IN FROM ANT". If it is the flat type (300-ohm), connect it to the Antenna Adaptor and slip the Adaptor on to the "IN FROM ANT" terminal.

3. Connect the 75-ohm Coaxial Cable with Antenna Adaptor to "OUT TO TV" on the RF Converter Unit.
4. Connect the other end to the VHF antenna terminal on the TV, as illustrated.
5. Connect the Connector Cable from RF Converter Unit to "AV OUT" jack on the Video Camera/Recorder.
6. Turn on the TV and set to Channel 3 unless Channel 3 is one of the TV stations in your area. If Channel 3 is used in your area, set your TV to Channel 4.
7. Set the RF Channel Selector on the RF Converter Unit to "CH3" or "CH4" to match the channel selector on your TV. This is the Video Camera/Recorder channel on your TV set. Your TV receiver must be tuned to this channel any time a video cassette is played back on the Video Camera/Recorder.

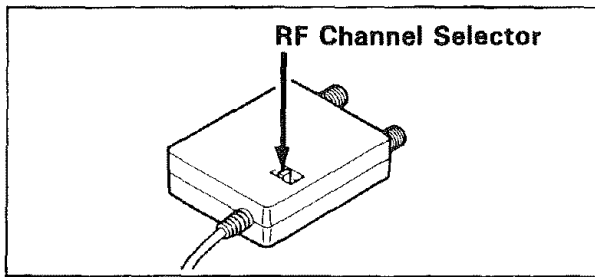

8. Press "EJECT" Button on the Video Camera/Recorder and then insert the cassette.

9. Set "VCR/CAM" Select Switch to "VCR" position.
10. Press "POWER" ON/OFF Button on.
11. Press "PLAY" Button.
12. After playing press "STOP" Button.

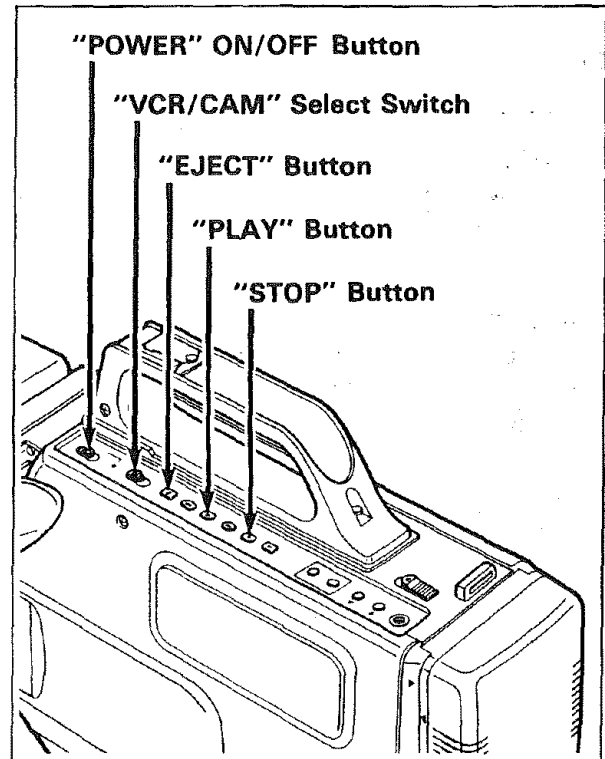

NOTE: If you want to watch a TV program with Video Camera/Recorder connected as illustrated, press "POWER" ON/OFF Button of the Video Camera/Recorder off, or disconnect the connector cable of RF Converter Unit from "AV OUT" jack on the Video Camera/Recorder.

Example 2: If your TV has "VIDEO IN" and "AUDIO IN" jacks,

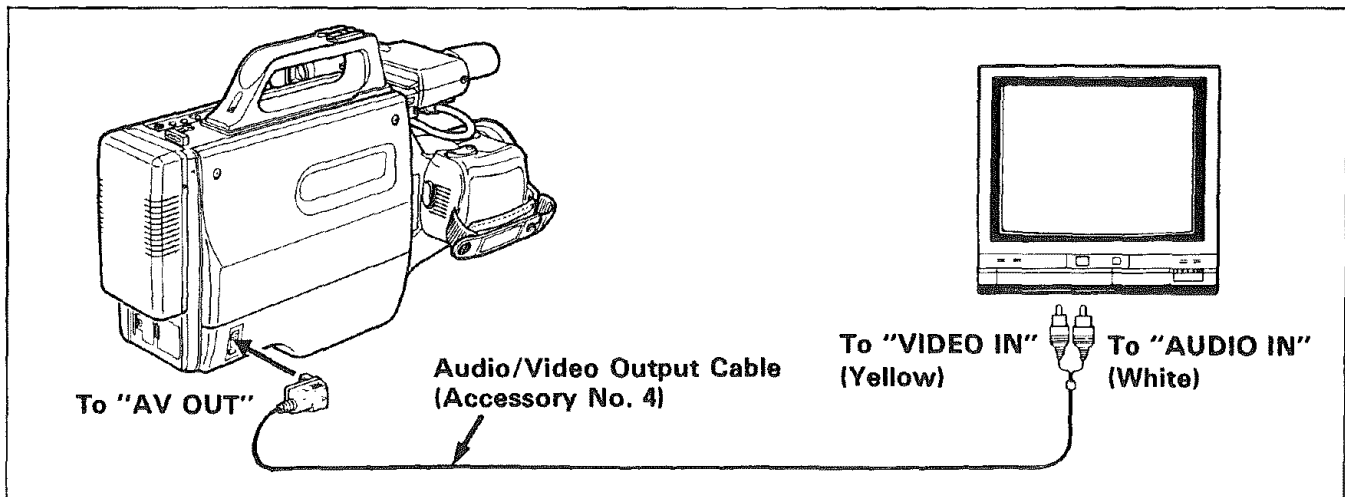

1. Connect the Audio/Video Output Cable (Accessory No. 4) to "AUDIO IN" and "VIDEO IN" of your TV.
2. Connect the other end of the Audio/Video Output Cable to "AV OUT" of your Video Camera/Recorder.
3. Turn on TV.
4. Perform same procedures in Steps 8 through 12 of "Example 1" above.

DISPLAY BUTTON

Pressing the "DISPLAY" button lets you check several special displays in the viewfinder.

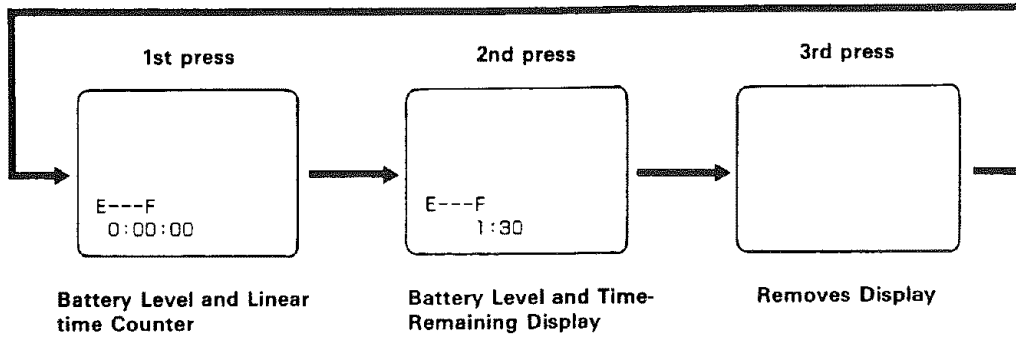
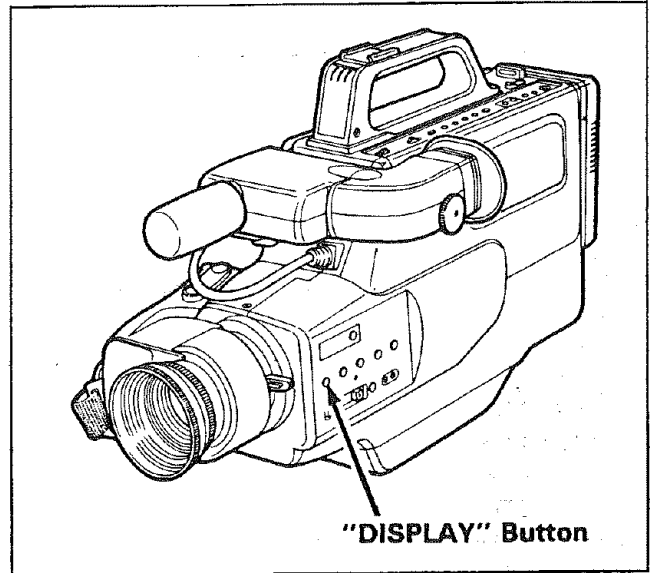

LINEAR TIME COUNTER

Shows length of tape run in hours, minutes and seconds. Press "DISPLAY" Button to select the linear time counter display.

Load a cassette into the camera/recorder and perform recording or playback; the counter indicates the elapsed time.

NOTE:

- The linear time counter does not operate when nothing is recorded on the tape.
- Counter changes to 0:00:00 when cassette is ejected.

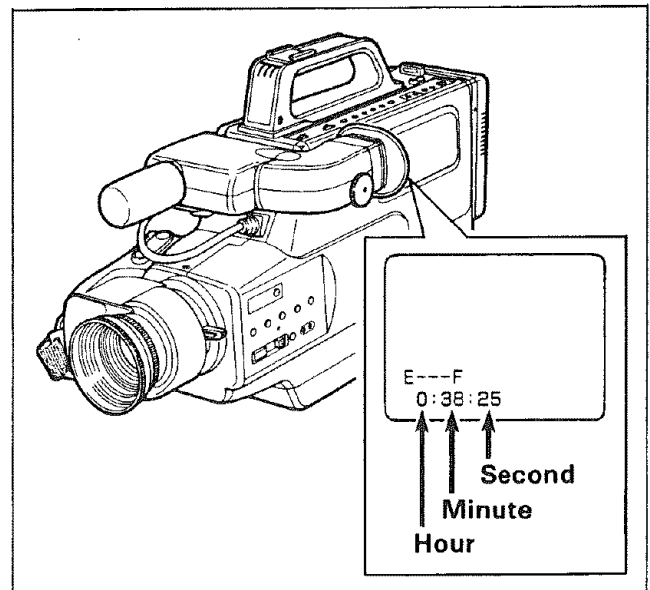

MEMORY

When the linear time counter with memory indication appears in the viewfinder, a tape that is being rewound automatically stops when the counter reads "0:00:00". This is useful if there is a section of tape you want to review immediately after recording or if you want to return to the same point several times in a row.

1. Press "DISPLAY" Button until the linear time counter is displayed.
2. Press "MEMORY" Button. (The indication "M" appears on the display).
3. Start playing or recording a tape.
4. At the point you want playback to start, press "RESET/T-160" Button to reset the counter to "0:00:00".
5. Continue to play or record.
6. Press "STOP" Button.
7. Press "REW" Button. The tape will be rewound to the preselected point, at "0:00:00" indication.

NOTE: The tape will also stop approximately at "0:00:00" during fast forward mode.

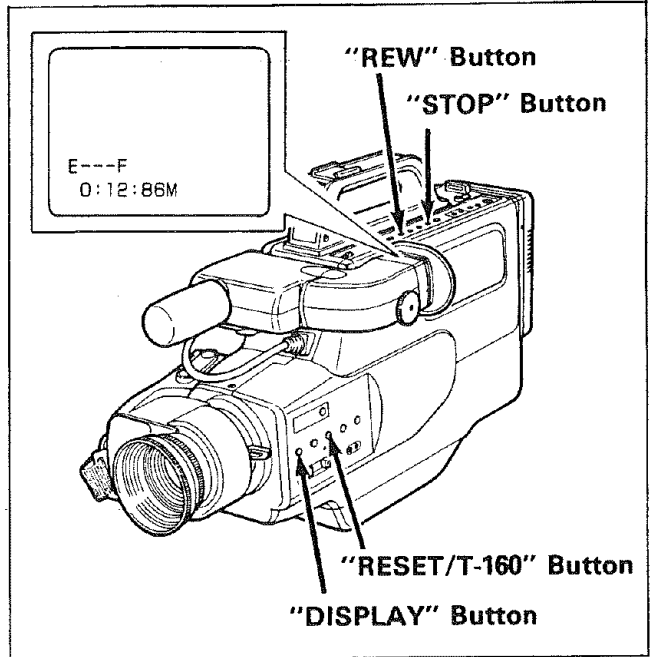

TIME REMAINING

When the linear time counter is present in the viewfinder, pressing "DISPLAY" Button again will change the display to a read-out showing the amount of recording or playback time left on the tape. Pressing "DISPLAY" Button once more clears all graphics from the viewfinder.

NOTE: When using an extended length T-160 cassette, you must press "RESET/T-160" Button to adapt the camera/recorder's time remaining system for an accurate read-out. (If the linear time counter is being displayed, "RESET/T-160" Button resets the counter to "0:00:00".)

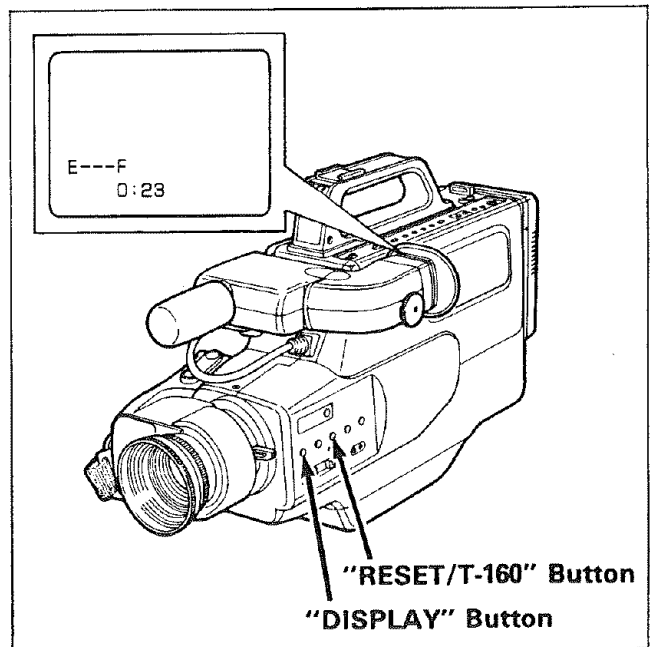

F-SEARCH AND R-SEARCH

When you press "F.FWD" or "REWIND" Button during playback, the tape will be played back at a speed about 3 times faster than the normal playback speed, and you can easily locate a certain spot on the tape.

NOTE: There will be some noise (interference) in the F-search or R-search pictures.

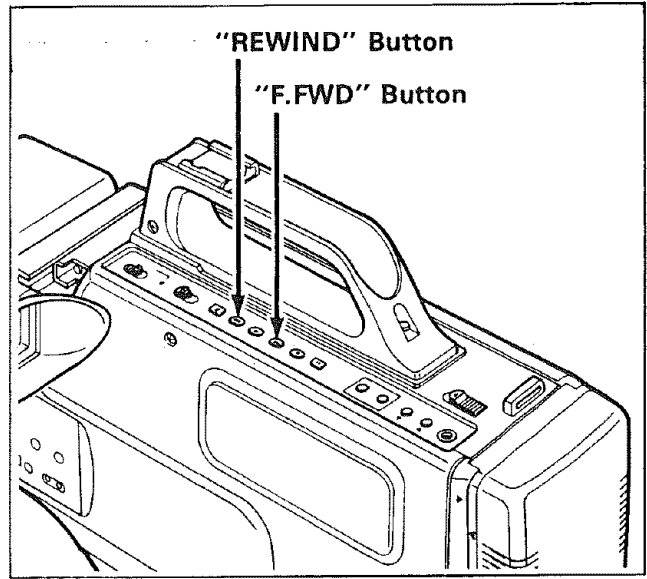
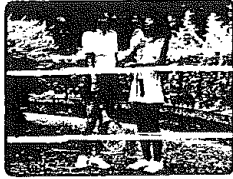

PAUSE

When "PAUSE" Button is pressed during playback, a still picture can be seen. To start again press "PAUSE" Button and playback will be resumed.

NOTES:

- There will be some noise (interference) in the still picture.
- After about 5 minutes of continuous still (play/pause) mode, the Camera/Recorder will go into the stop mode.

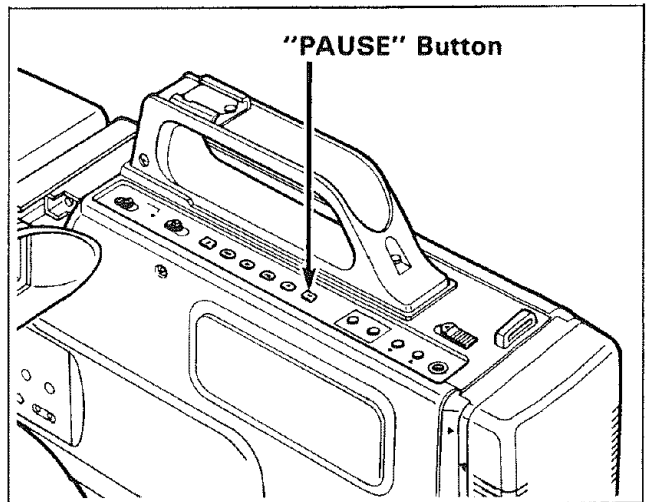

EDIT SEARCH

Edit Search means that you can use "F.FWD", "REW" and "PLAY" Buttons to precisely position the tape even while the "VCR/CAM" Select Switch is in "CAM" position.

Since you can do this while the Camera/Recorder is in the camera mode, without the tape unloading, it is possible to precisely position the tape for the next scene—eliminating the "between-scene glitches" that are common on Camera/Recorders without this feature. To permit smooth editing while recording, "F.FWD", "REW" and "PLAY" Buttons can be pressed while the "VCR/CAM" Select Switch is in "CAM" mode.

- Holding "REW" lets you quickly reverse scan recorded material.
- Holding "F.FWD" lets you quickly forward scan recorded material.
- Holding "PLAY" lets you view recorded material at normal speed. When you release the "PLAY" button, the Camera/Recorder will stop playing and prepare to record at that spot.

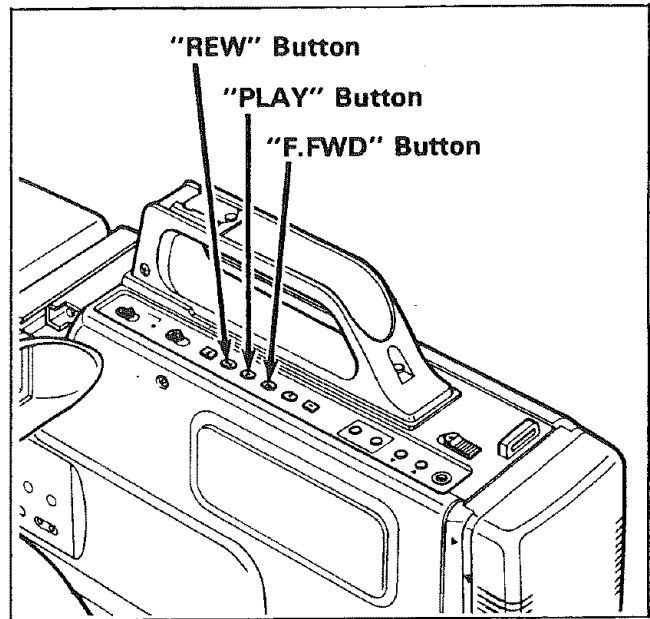

OPERATING HINTS

- * After you have finished using the Camera/Recorder, remove the cassette and the power source from the Camera/Recorder and attach the Lens Cap.

CAMERA/RECORDER TO VCR DUBBING

If you wish to exchange or copy some of your friend's favorite home recordings, the following instructions can be used to connect Video Camera/Recorder to VCR for this purpose.

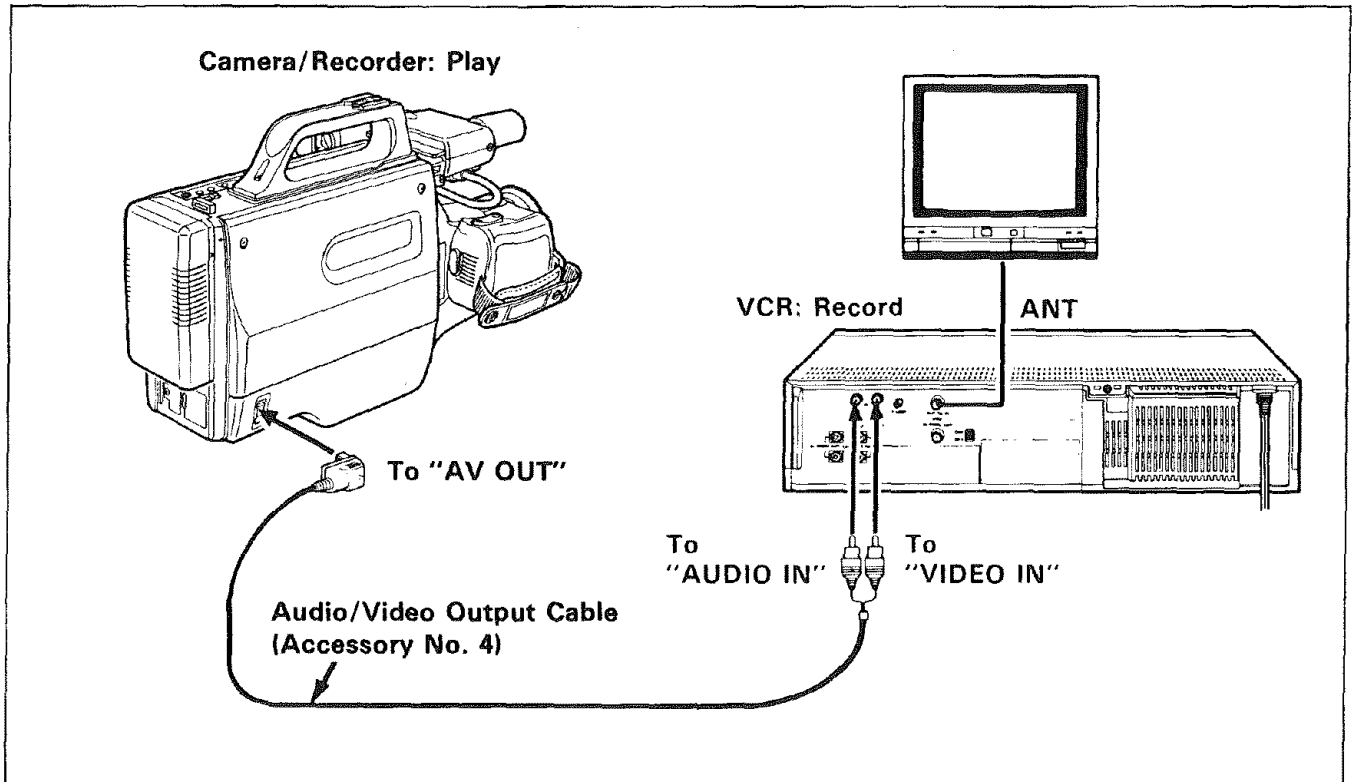

1. Connect the Audio/Video Output Cable (Accessory No. 4) to "AV OUT" of your Camera/Recorder.
2. Connect the other ends to "AUDIO IN", "VIDEO IN" respectively.
3. Play the tape on the Camera/Recorder and record it on the VCR.

NOTE: If you connect the "VHF OUT TO TV" connector of VCR to the "TV ANT" connector, as illustrated and set "VCR/TV" Selector of the VCR to "VCR" mode, the picture being dubbed by VCR can be monitored.

FLYING ERASE HEAD

A rotating erase head eliminates glitches and rainbow noise that occur at the joints between recordings. It also makes possible the new video dub feature of this Camera/Recorder.

TROUBLESHOOTING

Your Video Camera/Recorder is a highly sophisticated instrument. It has been carefully checked and adjusted at the factory under the most rigid quality control and inspection systems. However, should problems develop, check the following points and take necessary corrective measures.

INSERTING OR REMOVING THE CASSETTE

Symptom	Check Point & Correction
Cassette Holder cannot be opened when you press "EJECT" Button.	* Connect the Power Source.
Cassette cannot be inserted into Cassette Compartment.	* Load cassette in direction indicated by arrow on cassette.
	* Cassette window must be toward outside.

CAMERA RECORDING

Symptom	Check Point & Correction
Picture does not appear in the Viewfinder.	* Remove the Lens Cap.
	* Press "POWER" ON/OFF Button on.
	* Set "VCR/CAM" Select Switch to "CAM" position.
The Camera/Recorder will not go into the recording mode, even when Record Start/Stop Button is pressed.	* The cassette has had the erase prevention tab removed. Stick a piece of cellophane tape over the erase prevention hole or select a different cassette.
	* Set "VCR/CAM" Select Switch to "CAM" position.
Picture is out of focus.	* Set "FOCUS AUTO/MAN" Switch to "AUTO".
Auto-Focus does not operate.	* The Video Camera/Recorder is set to "MACRO" mode. Turn the Zoom Lever to release "MACRO" mode, and then focus on the object.
	* Auto-Focus does not operate if the Telephoto or Wide-angle lens is attached.

RECORDING TV PROGRAMS OFF THE AIR

Symptom	Check Point & Correction
The Camera/Recorder will not go into the recording mode, even when Record Start/Stop Button is pressed.	* The cassette has had the erase prevention tab removed. Stick a piece of cellophane tape over erase prevention tab hole or select a different cassette.
	* Set "VCR/CAM" Select Switch to "CAM" position.

PLAYBACK OF PRE-RECORDED CASSETTE

Symptom	Check Point & Correction
"PLAY" Button cannot be engaged.	* Set "VCR/CAM" Select Switch to "VCR" position.
No picture appears on television screen when "PLAY" Button is pressed. (TV is connected to the Camera/Recorder by using RF Converter Unit.)	* Set the television to the Camera/Recorder channel (3 or 4) depending upon the selected channel on the RF Channel Select Switch of RF Converter Unit.
Interference on playback picture.	* Adjust "TRACKING" Control.
	* When you see the playback picture on your TV, adjust fine tuning knob on television set to obtain best picture.
	* The pre-recorded tape is LP or EP recording. This Camera/Recorder is for use in SP recording only.
	* Take the Camera/Recorder to Sears Service Center for service.
Picture bends at the top of TV screen.	* TV receiver is of older type. It needs to be modified to work properly with Camera/Recorder.
	* Tape is damaged. Try another cassette.
Color of your TV screen is too bright, too faint or change.	* TV set has VIR circuit. Turn it off during playback.

DEW LIGHT

Symptom	Check Point & Correction
"DEW (POWER)" Light flashes.	* Condensation on the Camera/Recorder mechanism — wait until the Unit has reached normal room temperature, and condensation has dried. "DEW (POWER)" Light will then stop flashing.

BATTERY CONDITION

Symptom	Check Point & Correction
The "E" indication in the Electronic Viewfinder flashes to indicate Battery is discharged.	* Try another Battery or charge the Battery.

STORING THE CAMERA/RECORDER IN THE CARRYING CASE

- Place the cassette tape in the area marked "CASSETTE TAPE".
(Do not store the tape in the Camera/Recorder.)
- Place the Camera/Recorder in the case. (The handle should be near the case handle and the lens should point to the right.)
- Slide the viewfinder down as far as possible. (Don't force.) Rotate the eyepiece until it points toward the case handle. The viewfinder will now slide down a little further.

ROUTINE MAINTENANCE

Your Video Camera/Recorder is a highly sophisticated electro/mechanical device. It is normal for it to require routine cleaning and maintenance after approximately 1,000 hours of use. The exact schedule will depend on the condition in which it is used.

The necessity of maintenance will generally be indicated by a slight degeneration in picture or sound quality. Because of the delicate nature of Video Camera/Recorder, it is recommended that you take the Video Camera/Recorder to a Sears Service Center to have it cleaned and restored to "like new" operation.

SEARS SERVICE

Your Sears Video Camera/Recorder has added value when you consider that Sears has service units nationwide staffed with Sears trained technicians . . . professional technicians specifically trained on Sears home entertainment products, having the parts, tools and equipment to insure that we meet our pledge to you . . . "We Service What We Sell".

If you should take your Camera/Recorder to Sears Service for any reason, be sure you include the following accessories:

1. Audio/Video Output Cable (Accessory No. 4)
2. AC Adaptor/Charger (Accessory No. 3)

HOW TO ORDER REPAIR PARTS

Now that you have purchased your Video Camera/Recorder, should a need ever exist for repair parts or service, simply contact any Sears Service Center or Sears, Roebuck and Co. store. Be sure to provide all pertinent facts when you call or visit. When ordering parts by mail, selling prices will be furnished on request, or parts will be shipped at current selling prices and you will be billed accordingly.

The Model Number will be found on the bottom of cabinet. Always mention the Model Number when requesting service or repair parts for your Video Camera/Recorder.

WHEN ORDERING REPAIR PARTS, ALWAYS GIVE THE FOLLOWING INFORMATION:

1. NAME of ITEM Sears Video Camera/Recorder
2. MODEL NUMBER
3. PART DESCRIPTION

SPECIFICATIONS

■ General

Power requirements	9.6V DC
Power consumption	9.6 watts (nominal)
Dimensions	4-3/4"(W) x 9"(H) x 14-1/2"(D) 121(W) x 228(H) x 368(D) mm
Weight	4.9 lbs (2.2 kg)

■ Video Recorder Section

Format	VHS
Record/playback system	Two video record/playback heads plus a flying erase head
Video signal	EIA standard NTSC color
Tape speed	33.35 mm/sec.
Video input	1.0 Vp-p, 75 ohm
Video output	1.0 Vp-p, 75 ohm
Audio input	-7.8 dBs (316 m Vrms), more than 47K ohms
Audio output	-7.8 dBs (316 m Vrms), less than 1K ohm
Fast forward/rewind time	Less than 10 minutes with T-160 cassette

■ Camera Section

Scanning	525 lines/60 fields/30 frames
Required minimum illumination	2 lux
Pickup device	1/2" C.C.D.
Lens diameter	46 mm

USING THE OPTIONAL SYNCHRO EDIT CORD

Synchro edit allows your Camera/Recorder to control a compatible VCR (one that has a camera pause jack) while tapes are being copied from the Camera/Recorder to the VCR. The "REVIEW" Button on the Camera/Recorder causes the VCR to start recording and the "REW", "F.FWD", "STOP" and "PAUSE" Buttons cause the VCR to stop recording. This is convenient when you want to record only selected segments from a previously recorded tape.

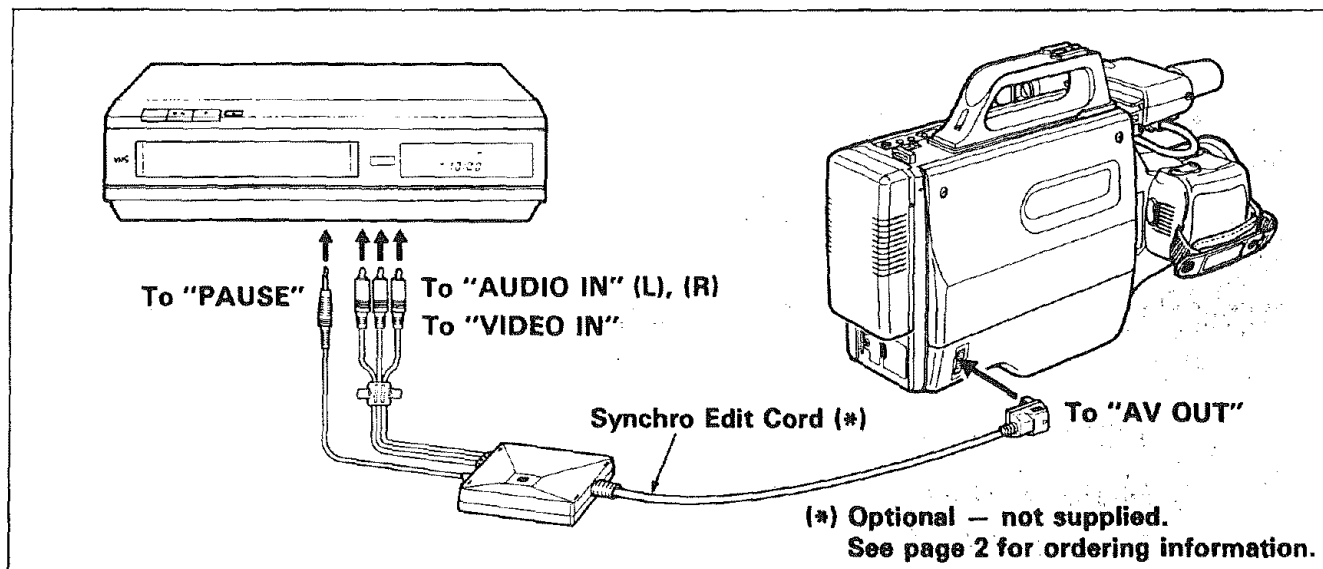

1. Connect your Camera/Recorder to a compatible VCR as shown above. An optional synchro edit cord is required.

NOTE: If your VCR has a single (mono) audio input, connect either the left or right audio plug to the audio input on the VCR.

2. Insert the recorded tape into the Camera/Recorder and blank tape into the recording VCR.
3. Press "PLAY" Button on the Camera/Recorder and then press "PAUSE" Button where you want to copy.
4. Press "RECORD" Button on the VCR. The VCR automatically enters record/pause mode.

NOTE: If the VCR begins to record instead of pausing, you will need to change the position of the switch on the synchro edit cord. Stop the VCR, change the switch, and then press "RECORD" Button on the VCR again.

5. Pressing "REVIEW" Button on the Camera/Recorder puts the Camera/Recorder in the review mode for several seconds and then into the playback mode. The recording VCR starts recording automatically.

6. Pressing "REW", "F.FWD", "STOP" or "PAUSE" on the Camera/Recorder automatically put the VCR into the record/pause mode. This allows you to search (forward or backward), fast-forward or rewind the tape in the Camera/Recorder without disturbing the tape in the VCR.

- To search forward (or backward), press "F.FWD" (or "REW") Button. Press "PLAY" Button, the Camera/Recorder will resume normal playback. To begin copying again, press "PAUSE" Button and then the "REVIEW" Button.
- To fast-forward (or rewind) the tape, press "STOP" then "F.FWD" (or "REW"). To begin copying again, press "STOP", then "PLAY", then "PAUSE" to pause the Camera/Recorder, and "REVIEW" to begin copying.

OWNERS MANUAL

MODEL NO.
934.53734090
SERIES

VHS

VIDEO CAMERA/ RECORDER

WARRANTY

FULL ONE YEAR WARRANTY ON VIDEO CAMERA/RECORDER

For one year from the date of purchase, Sears will repair any defect in material or workmanship in this video camera/recorder, free of charge.

The above warranty coverage applies only to video camera/recorders which are used for private household purposes.

TO OBTAIN WARRANTY SERVICE, SIMPLY RETURN THE VIDEO CAMERA/RECORDER TO THE NEAREST SEARS SERVICE CENTER/DEPARTMENT IN THE UNITED STATES.

This warranty gives you specific legal rights, and you may also have other rights which vary from state to state.

Sears, Roebuck and Co.

Dept. 731CR-W, Sears Tower, Chicago, IL 60684