

IMPORTANT MANUAL

DO NOT THROW AWAY

**SEARS
OWNER'S
MANUAL**

**MODEL NO.
536.884351**

**Caution:
Read and Follow
All Safety Rules
and Instructions
Before Operating
This Equipment**

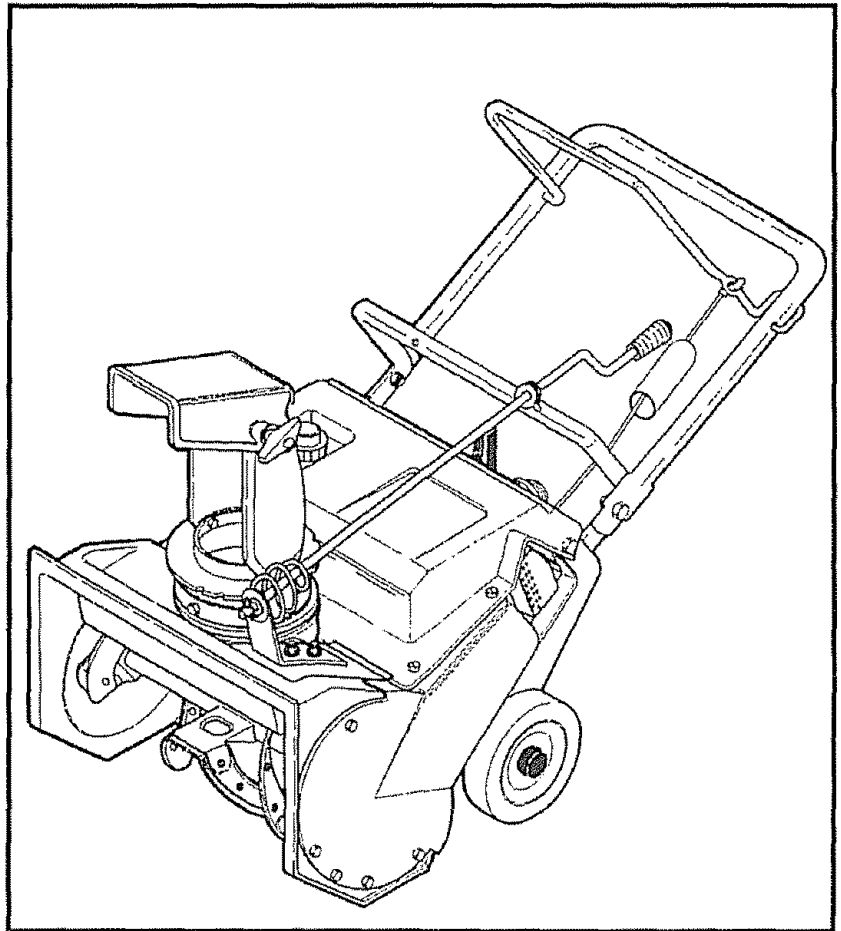

CRAFTSMAN®

**3 HORSEPOWER
20" SINGLE STAGE
AUGER PROPELLED
120V ELECTRIC START
SNOW THROWER**

- Assembly
- Operation
- Customer Responsibilities
- Service and Adjustments
- Repair Parts

SEARS, ROEBUCK AND CO., Hoffman Estates, IL 60179 U.S.A.

SAFETY RULES



CAUTION. ALWAYS DISCONNECT SPARK PLUG WIRE AND PLACE WIRE WHERE IT CANNOT CONTACT SPARK PLUG TO PREVENT ACCIDENTAL STARTING WHEN SETTING-UP, TRANSPORTING, ADJUSTING OR MAKING REPAIRS.



IMPORTANT

SAFETY STANDARDS REQUIRE OPERATOR PRESENCE CONTROLS TO MINIMIZE THE RISK OF INJURY. YOUR SNOW THROWER IS EQUIPPED WITH SUCH CONTROLS. DO NOT ATTEMPT TO DEFEAT THE FUNCTION OF THE OPERATOR PRESENCE CONTROL UNDER ANY CIRCUMSTANCES.

BEFORE USE

- Read the Owner's Manual carefully. Be thoroughly familiar with the controls and the proper use of the snow thrower. Know how to stop the snow thrower and disengage the controls quickly.
- Do not operate the snow thrower without wearing adequate winter outer garments. Wear footwear that will improve footing on slippery surfaces.
- Keep the area of operation clear of all persons, particularly small children, and pets.
- Thoroughly inspect the area where the snow thrower is to be used and remove all doormats, sleds, boards, wires, and other foreign objects.
- Use extension cords and receptacles as specified by the manufacturer for all snow throwers with electric drive motors or with factory-installed or optional starting motors.
- Use only attachments and accessories approved by the manufacturer of the snow thrower (such as electric starter kits, etc.)
- Never operate the snow thrower without good visibility or light. Always be sure of your footing, and keep a firm hold on the handles. Walk; never run.
- This snow thrower is for use on sidewalks, driveways, and other ground level surfaces. CAUTION should be exercised while using on steep sloping surfaces. DO NOT USE SNOW THROWER ON SURFACES ABOVE GROUND LEVEL such as roofs of residences, garages, porches or other such structures or buildings.
- Check all bolts at frequent intervals for proper tightness to be sure the snow thrower is in safe working condition.
- Disengage clutch before starting the engine.
- Let engine and snow thrower adjust to outdoor temperatures before starting to clear snow.

FUEL SAFETY

- Handle fuel with care; it is highly flammable.
- Use an approved fuel container.
- Check fuel supply before each use, allowing space for expansion as the heat of the engine and/or sun can cause fuel to expand.
- Fill fuel tank outdoors with extreme care. Never fill fuel tank indoors.
- Replace fuel tank cap securely and wipe up spilled fuel.
- Never remove fuel tank cap or add fuel to a running engine or hot engine.
- Never store fuel or snow thrower with fuel in the tank inside a building where fumes may reach an open flame or spark.

OPERATING SAFETY

- Never allow children or young teenagers to operate the snow thrower and keep them away while it is operating. Never allow adults to operate the snow thrower without proper instruction. Do not carry passengers.
- Always wear safety glasses or eye shields during operation or while performing an adjustment or repair to protect eyes from foreign objects that may be thrown from the snow thrower.
- Exercise extreme caution when operating on or crossing gravel drives, walks, or roads. Stay alert for hidden hazards or traffic.
- Do not put hands or feet near or under rotating parts. Keep clear of the discharge opening at all times.
- Exercise caution to avoid slipping or falling, especially when operating in reverse or backing up.
- Do not clear snow across the face of slopes. Exercise caution when changing direction on slopes. Do not attempt to clear steep slopes.
- Never operate the snow thrower without proper guards, plates or other safety protective devices in place.

SAFETY RULES

8. Do not run the engine indoors, except when starting the engine and for transporting the snow thrower in or out of the building. Open the outside doors; exhaust fumes are dangerous (containing CARBON MONOXIDE, an ODORLESS and DEADLY GAS).
9. Do not clear snow across the face of slopes. Exercise caution when changing direction on slopes. Do not attempt to clear steep slopes.
10. Never operate the snow thrower without proper guards, plates or other safety protective devices in place.
11. Never operate the snow thrower near glass enclosures, automobiles, window wells, drop-offs, and the like without proper adjustment of the snow discharge angle. Keep children and pets away.
12. Do not overload the machine capacity by attempting to clear snow at too fast a rate.
13. Never operate the snow thrower at high transport speeds on slippery surfaces. Look behind and use care when backing.
14. Never direct discharge at bystanders or allow anyone in front of the snow thrower.
15. Disengage power to the auger/impeller when snow thrower is transported or not in use.
16. Use only attachments and accessories approved by the manufacturer of the snow thrower (such as tire chains, electric start kits, etc.).
17. Never operate the snow thrower without good visibility or light. Always be sure of your footing, and keep a firm hold on the handles. Walk; never run.

MAINTENANCE AND STORAGE

1. Check shear bolts and other bolts frequently for improper tightness to be sure the snow thrower is in safe working condition.
2. Never store the snow thrower with fuel in the fuel tank inside a building where ignition sources are present such as hot water and space heaters, clothes dryers, and the like. Allow the engine to cool before storing in any enclosure.
3. Always refer to operator's manual instructions for important details if the snow thrower is to be stored for an extended period.
4. Maintain or replace safety and instruction labels, as necessary.
5. Run the snow thrower a few minutes after throwing snow to prevent freeze-up of the auger/impeller.

WARNING

This snow thrower is for use on sidewalks, driveways, and other ground level surfaces.

CAUTION should be exercised while using on steep sloping surfaces. **DO NOT USE SNOW THROWER ON SURFACES ABOVE GROUND LEVEL** such as roofs of residences, garages, porches or other such structures or buildings.

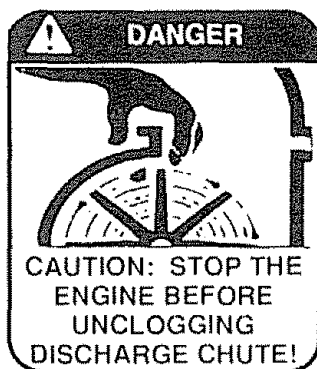

LOOK FOR THIS SYMBOL TO POINT OUT IMPORTANT SAFETY PRECAUTIONS. IT MEANS--ATTENTION!!! BECOME ALERT!!! YOUR SAFETY IS INVOLVED.

CONGRATULATIONS on your purchase of a Sears Craftsman Snow Thrower. It has been designed, engineered and manufactured to give you the best possible dependability and performance.

Should you experience any problem you cannot easily remedy, please contact your nearest Sears Service Center/Department. Sears has competent, well-trained technicians and the proper tools to service or repair this unit.

Please read and retain this manual. The instructions will enable you to assemble and maintain your snow thrower properly. Always observe the "SAFETY RULES."

<p>MODEL NUMBER 536 884351</p> <p>SERIAL NUMBER _____</p> <p>DATE OF PURCHASE _____</p> <p>THE MODEL AND SERIAL NUMBERS WILL BE FOUND ON A DECAL ATTACHED TO THE REAR OF THE SNOW THROWER HOUSING.</p> <p>YOU SHOULD RECORD BOTH SERIAL NUMBER AND DATE OF PURCHASE AND KEEP IN A SAFE PLACE FOR FUTURE REFERENCE.</p>
--

PRODUCT SPECIFICATIONS

HORSE POWER:	3 hp
DISPLACEMENT:	6.0 cu. in.
GASOLINE CAPACITY:	1 quart Unleaded
FUEL/OIL MIX RATIO:	40:1 (3.2 oz of air-cooled engine 2 cycle oil specified for 40:1 ratio per 1 gal of gas)
SPARK PLUG : (GAP .030 in.)	Champion RJC8Y or CJ8Y

MAINTENANCE AGREEMENT

A Sears Maintenance Agreement is available on this product. Contact your nearest Sears Store for details.

CUSTOMER RESPONSIBILITIES

- Read and observe the safety rules
- Follow a regular schedule in maintaining, caring for and using your snow thrower.
- Follow the instructions under "Customer Responsibilities" and "Storage" sections of this Owner's Manual.

ONE YEAR LIMITED WARRANTY ON CRAFTSMAN SNOW THROWER

For one year from the date of purchase, when this Craftsman Snow Thrower is maintained, lubricated and tuned-up according to the instructions in the owner's manual, Sears will repair, free of charge, any defect in material and workmanship.

If this Craftsman Snow Thrower is used for commercial or rental purposes, this warranty applies for only 90 days from the date of purchase.

This warranty does not cover:

- Expendable items which become worn during normal use, such as spark plugs, drive belts and shear pins
- Repairs necessary because of operator abuse or negligence, including bent crankshafts and the failure to maintain the equipment according to the instructions contained in the owner's manual.

WARRANTY SERVICE IS AVAILABLE BY RETURNING THE CRAFTSMAN SNOW THROWER TO THE NEAREST SEARS SERVICE CENTER/DEPARTMENT IN THE UNITED STATES. THIS WARRANTY APPLIES ONLY WHILE THIS PRODUCT IS IN USE IN THE UNITED STATES.

This warranty gives you specific legal rights, and you may also have other rights which may vary from state to state.

SEARS, ROEBUCK AND CO , D/817WA, HOFFMAN ESTATES, IL 60179

TABLE OF CONTENTS

SAFETY RULES	2-3	OPERATION	8-12
PRODUCT SPECIFICATIONS	4	SERVICE AND ADJUSTMENTS	14-16
CUSTOMER RESPONSIBILITIES	4,13	STORAGE	17
WARRANTY	4	TROUBLE SHOOTING	18
TABLE OF CONTENTS	5	REPAIR PARTS (SNOW THROWER)	20-27
INDEX	5	REPAIR PARTS (ENGINE)	28-30
ASSEMBLY	6-7	PARTS ORDERING/SERVICE	Back Cover

INDEX

<p style="text-align: center;">A</p> <p>Adjustment:</p> <ul style="list-style-type: none"> Auger Control Cable 14 Auger 16 Drive Belt 15 Carburetor 14 Spark Plug 13, 16 <p>Assembly:</p> <ul style="list-style-type: none"> Check list 7 Chute Control Rod Assembly 7 Handle Assembly 7 Unpacking 6 <p style="text-align: center;">B</p> <p>Belt:</p> <ul style="list-style-type: none"> Adjust Belt 15 Belt Maintenance 15 Replace Belt 15 <p style="text-align: center;">C</p> <p>Carburetor, Adjustment 14</p> <p>Choke Control 8, 11, 12</p> <p>Primer Button 8, 11, 12</p> <p>Controls:</p> <ul style="list-style-type: none"> Auger 8, 9 Snow Thrower 8-9, 11, 12 <p>Customer Responsibilities 4,13</p> <ul style="list-style-type: none"> Agreement 4 Carburetor 13 Engine 13 Lubrication Chart 13 Spark Plug 13 General Recommendations 13 <p style="text-align: center;">D</p> <p>Drive, Auger 9, 15</p> <p>Deflector, Snow Chute 8-9, 12</p>	<p style="text-align: center;">E</p> <p>Engine:</p> <ul style="list-style-type: none"> Controls 8, 11, 12 Fuel Mix Ratio 4, 10 Oil Type 4, 10 Starting, Electric 11 Starting, Recoil 11, 12 Storage 17 <p>Electric Start 8, 11</p> <p style="text-align: center;">F</p> <p>Fuel Mix Ratio 4, 10</p> <p>Fuel, Type 4, 10</p> <p>Fuel, Storage 10, 17</p> <p style="text-align: center;">H</p> <p>Handle, Upper 7</p> <p style="text-align: center;">I</p> <p>Ignition, Key 8, 11, 12</p> <p>Index 5</p> <p style="text-align: center;">L</p> <p>Levers:</p> <ul style="list-style-type: none"> Choke Control 8, 11, 12 Chute Control 8-9, 12 <p>Lubrication:</p> <ul style="list-style-type: none"> Chute Control Rod 14, 13 Chute Flange 13 <p style="text-align: center;">O</p> <p>Oil:</p> <ul style="list-style-type: none"> Engine 10 Storage 17 Type 4, 10 <p>Operation:</p> <ul style="list-style-type: none"> Carburetor 11 Engine and Auger Controls 8, 11, 12, 16 Operating Snow Thrower 8-9, 12 Operating Tips 12 Starting the Engine, Electric 11 Starting the Engine, Recoil 11-12 Snow Thrower Controls 8-9, 12 	<p style="text-align: center;">P</p> <p>Parts 20-30</p> <p>Primer Button 8, 11-12</p> <p>Product Specifications 4</p> <p style="text-align: center;">R</p> <p>Repair/Replacement Parts 20-30</p> <p>Recoil Starter 8, 11-12</p> <p>Replacement, Belts 15</p> <p style="text-align: center;">S</p> <p>Safety Rules 2-3</p> <p>Service and Adjustments:</p> <ul style="list-style-type: none"> Auger 16 Auger Control Cable 14 Drive Belt 15 Belt Replacement 15 Carburetor 14 Spark Plug 13, 16 Specifications 4 Starting the Engine, Electric 11 Starting the Engine, Recoil 11-12 Stopping the Snow Thrower 9 Shipping Carton 6 Storage 17 <p style="text-align: center;">T</p> <p>Table of Contents 5</p> <p>Trouble Shooting Chart 18</p> <p>Tools Required for Assembly 6</p> <p style="text-align: center;">W</p> <p>Warranty 4</p>
---	--	---

CONTENTS OF HARDWARE PACK

CONTENTS OF PARTS BAG (not shown full size)

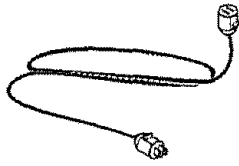

1 - Electric Starter Cord 10 Ft.



1 - 3.2 ounce container
Craftsman 2-cycle oil

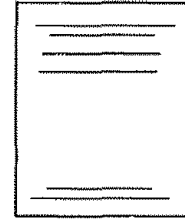

1 - Owner's manual

Parts packed separately in carton (not shown full size)

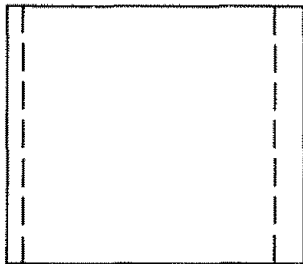

1 - Parts Bag

ASSEMBLY

TOOLS REQUIRED FOR ASSEMBLY

- 1 - Knife to cut carton



CAUTION: Always wear safety glasses or eye shields while assembling snow thrower.

Figure 1 shows the snow thrower completely assembled. Reference to the right and left hand side of the snow thrower is from the operator position at the handle.

TO REMOVE SNOW THROWER FROM CARTON

- Locate and remove container of Craftsman 2-cycle oil.
- Remove the inserts positioned around the unit and the packing material
- Cut down all four corners of the carton and lay the panels flat
- Pull snow thrower out of the carton.

ASSEMBLY

TO ASSEMBLE THE HANDLE

- Remove wrap on upper handle and along the side of both handles. Discard wrap.
- Loosen the tee knobs on each side of the upper handle (See Fig. 1).
- Raise the upper handle to the operating position as shown in Fig. 1. **NOTE:** Hold upper handle apart to prevent scratching lower handle.
- Check to be sure the clutch cable is not caught in the handle. Tighten the tee knobs.
- Remove wrap from handle of the chute control rod.

TO ASSEMBLE THE CHUTE CONTROL ROD

- Cut tie holding chute control rod to bracket.
- Remove the cotter pin, wave washer and flatwasher from the worm end of the chute control rod and set aside (See Fig. 2).
- Insert the worm end of the chute control rod through the hole in the chute control rod bracket while inserting the worm into the notches in the discharge chute rotation ring (See Fig. 2).
- Secure the end of the chute control rod in the chute control rod bracket with the wave washer, flatwasher and cotter pin (See Fig. 2).
- Rotate the chute control rod fully clockwise and counterclockwise. The discharge chute should rotate freely without binding.

✓ CHECKLIST

BEFORE YOU OPERATE AND ENJOY YOUR NEW SNOW THROWER, WE WISH TO ASSURE THAT YOU RECEIVE THE BEST PERFORMANCE AND SATISFACTION FROM THIS QUALITY PRODUCT.

PLEASE REVIEW THE FOLLOWING CHECKLIST:

- ✓ All assembly instructions have been completed
- ✓ The discharge chute rotates freely.
- ✓ No remaining loose parts in carton

WHILE LEARNING HOW TO USE YOUR SNOW THROWER, PAY EXTRA ATTENTION TO THE FOLLOWING IMPORTANT ITEMS:

- ✓✓ Make sure gas tank is filled with the correct mixture of gasoline and oil.
- ✓✓ Become familiar with all controls-their location and function. Operate controls before starting engine.

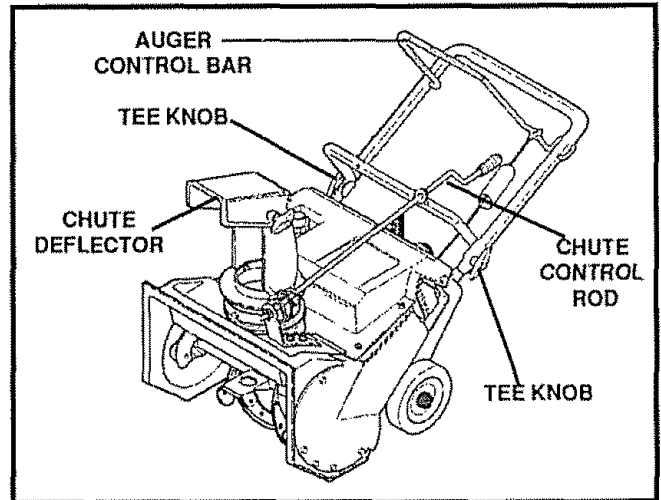

FIG. 1

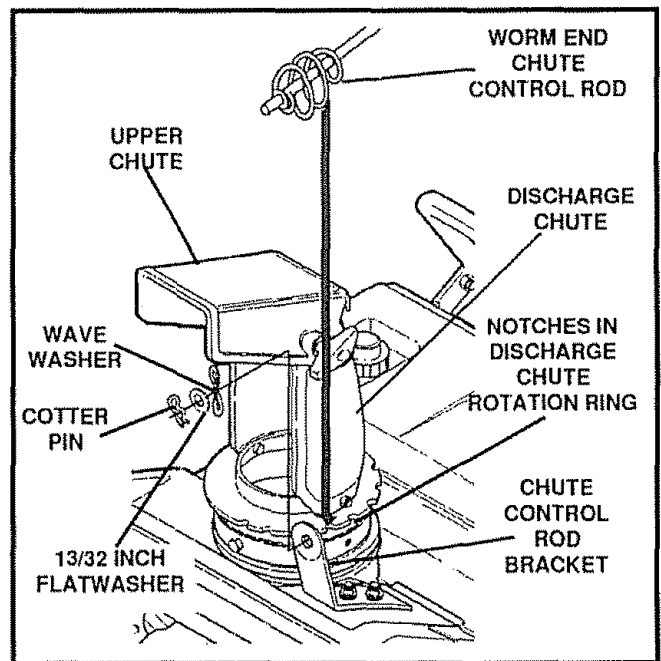

FIG. 2

OPERATION

KNOW YOUR SNOW THROWER

READ THIS OWNER'S MANUAL AND SAFETY RULES BEFORE OPERATING YOUR SNOW THROWER. Compare the illustrations with your snow thrower to familiarize yourself with the location of various controls and adjustments. Save this manual for future reference.

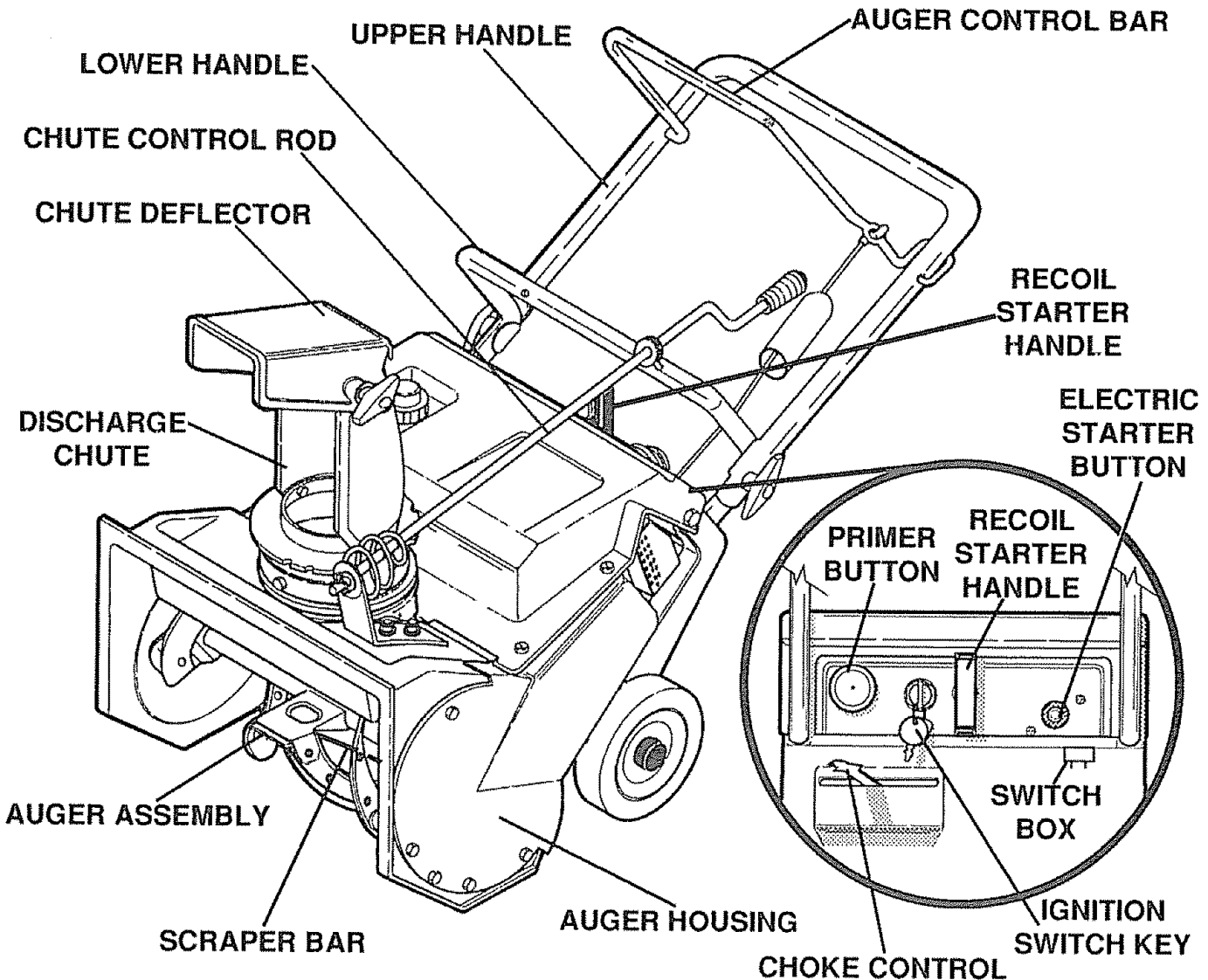

FIG. 2

SEARS SNOW THROWERS conform to the safety standards of the American National Standards Institute B71.3-1984

AUGER CONTROL BAR - Starts and stops the auger which propels the snow thrower

CHUTE CONTROL ROD - Changes the direction of snow discharge.

CHUTE DEFLECTOR - Changes the distance the snow is thrown.

DISCHARGE CHUTE - Changes the direction the snow is thrown.

IGNITION SWITCH KEY - Must be inserted and turned to the ON position to start the engine

CHOKER CONTROL - Used to start a cold engine.

PRIMER BUTTON - Injects fuel directly into the carburetor manifold for fast starts in cold weather.

RECOIL STARTER HANDLE - Starts the engine manually.

ELECTRIC STARTER BUTTON - Used to start the engine using the 120 V electric starter

OPERATION



The operation of any snow thrower can result in foreign objects being thrown into the eyes, which can result in severe eye damage. Always wear safety glasses or eye shields while operating the snow thrower.

We recommend standard safety glasses or a wide vision safety mask for over your glasses, available at SEARS Retail Stores or SEARS Service Centers

HOW TO USE YOUR SNOW THROWER

TO STOP YOUR SNOW THROWER

- To stop the auger, release the auger control bar.

NOTE: If the auger continues to creep, refer To Adjust Auger Control Cable paragraph on page 14.

- To stop the engine, turn key to the OFF position.

TO CONTROL SNOW DISCHARGE

- Turn the chute control rod to set the **direction** of the snow throwing.
- Loosen the wing knob on the chute deflector and move the deflector to set the **distance**. Move the deflector **UP** for more distance, **DOWN** for less distance. Then tighten the wing knob (See Fig. 3).

TO USE AUGER PROPEL ACTION

- Squeeze the auger control bar down against the upper handle to allow the auger to turn.
- To propel forward, raise the handle to allow the rubber auger blades to contact the ground (See Fig 4).

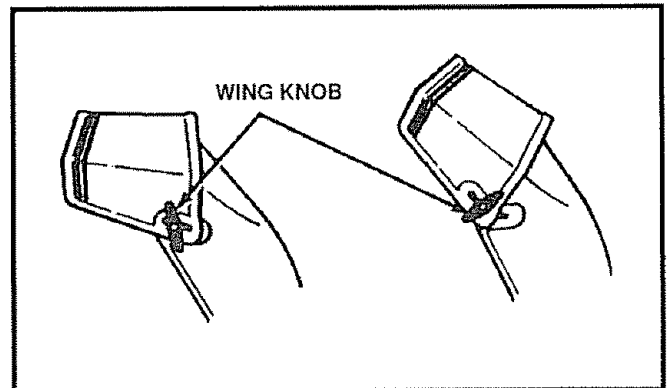

FIG. 3

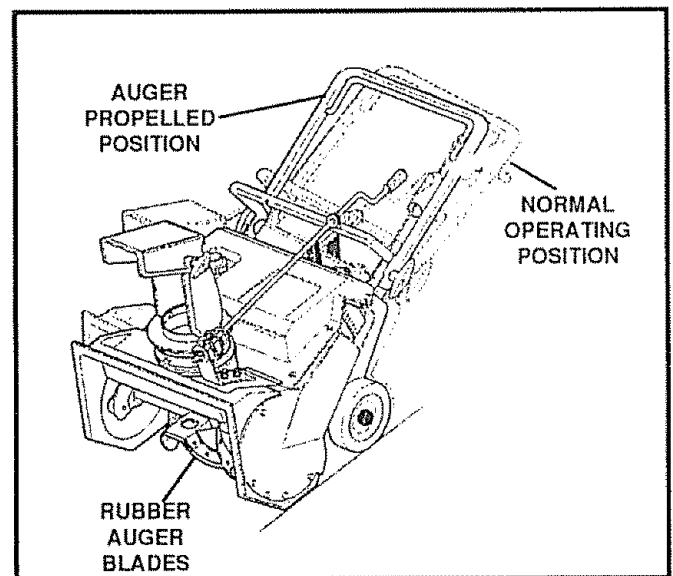

FIG. 4

CAUTION: READ OWNER'S MANUAL BEFORE OPERATING MACHINE.



NEVER DIRECT DISCHARGE TOWARD BYSTANDERS.

RELEASE THE AUGER CONTROL BAR AND STOP THE ENGINE BEFORE UN-CLOGGING DISCHARGE CHUTE OR AUGER HOUSING AND BEFORE LEAVING THE MACHINE.

OPERATION

BEFORE STARTING ENGINE

WARNING: Experience indicates that alcohol blended fuels (called gasohol or those using ethanol or methanol) can attract moisture which leads to separation and formation of acids during storage. Acidic gas can damage the fuel system of an engine while in storage. To avoid engine problems, the fuel system should be emptied before storage for 30 days or longer. Start engine and let it run until fuel lines and carburetor are empty. Use carburetor bowl drain to empty residual gasoline from float chamber (See Fig. 16). Use fresh fuel next season. (See Storage Instructions on page 17 for additional information.)

Never use engine or carburetor cleaner products in the fuel tank or permanent damage may occur.

FILL GAS

The two cycle engine used on this snow thrower requires a mixture of gasoline and oil for lubrication of the bearings and other moving parts. The correct fuel mixture ratio is 40:1 (3.2 oz. oil per gallon of gas - see Fuel Mixture Chart). Gasoline and oil must be pre-mixed in a clean gasoline container. Always use fresh, clean, unleaded gasoline.

FUEL MIX CHART (Mixture 40:1)

U. S.		IMPERIAL		S. I. (METRIC)	
GAS	OIL	GAS	OIL	GAS	OIL
1 Gal.	3.2 oz.	1 Gal.	3.7 oz.	4 Liters	100ML

GASOLINE AND OIL MIXTURE

Mix gasoline and oil (See Fig. 5) as follows:

- Pour 1 U.S. quart of fresh, clean, unleaded automotive gasoline to a gallon gasoline container.
- Add (3.2 oz.) of clean, high quality, Craftsman two-cycle oil into the gasoline container. (One-3.2 ounces of oil provided)

IMPORTANT: DO NOT USE OUTBOARD MOTOR OIL OR AUTOMOBILE OILS, SUCH AS SAE 30 OIL, OR MULTI-VIS-COSITY OILS, SUCH AS 10W-30 OR 10W-40

- Reinstall the cap on the gasoline container and shake container vigorously so the oil mixes with the gasoline
- Add an additional 3 U.S. quarts of gasoline to the gallon container and shake the container again.



CAUTION: GASOLINE IS FLAMMABLE AND CAUTION MUST BE USED WHEN HANDLING OR STORING IT. DO NOT FILL FUEL TANK WHILE SNOW THROWER IS RUNNING, HOT, OR WHEN SNOW THROWER IS IN AN ENCLOSED AREA. KEEP AWAY FROM OPEN FLAME OR ELECTRICAL SPARK, AND DO NOT SMOKE WHILE MIXING FUEL OR FILLING FUEL TANK. NEVER FILL FUEL TANK COMPLETELY, BUT FILL TANK TO WITHIN 1/4 -1/2 INCH FROM TOP TO PROVIDE SPACE FOR EXPANSION OF FUEL. ALWAYS FILL FUEL TANK OUTDOORS AND USE A FUNNEL OR SPOUT TO PREVENT SPILLING. MAKE SURE TO WIPE UP ANY SPILLED FUEL BEFORE STARTING ENGINE.

STORE GASOLINE IN A CLEAN, APPROVED CONTAINER, AND KEEP CAP IN PLACE ON CONTAINER. KEEP GASOLINE IN A COOL, WELL VENTILATED PLACE, NEVER IN THE HOUSE. NEVER BUY MORE THAN A 30 DAY SUPPLY OF GASOLINE TO ASSURE VOLATILITY. GASOLINE IS INTENDED TO BE USED AS A FUEL FOR INTERNAL COMBUSTION ENGINES; THEREFORE, DO NOT USE GASOLINE FOR ANY OTHER PURPOSE. SINCE MANY CHILDREN LIKE THE SMELL OF GASOLINE, KEEP IT OUT OF THEIR REACH BECAUSE THE FUMES ARE DANGEROUS TO INHALE, AS WELL AS BEING EXPLOSIVE.

DO NOT FILL THE FUEL TANK WITH GASOLINE THAT DOES NOT HAVE OIL MIXED IN IT. SHAKE THE GASOLINE CONTAINER BEFORE EACH FILLING OF THE FUEL TANK.

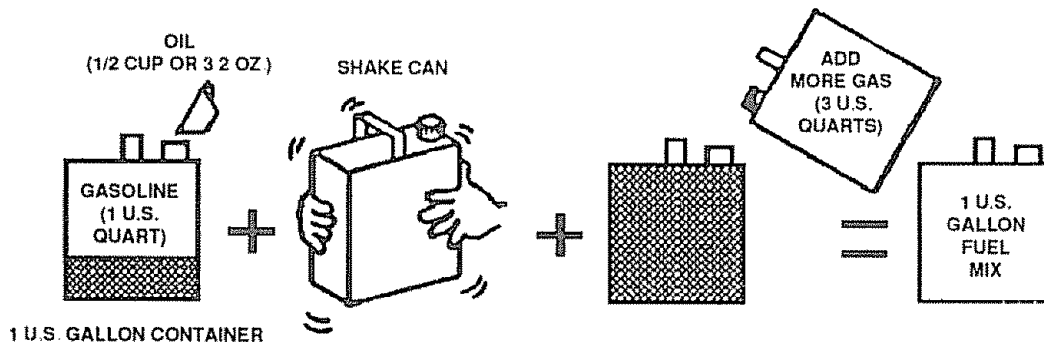

FIG. 5

OPERATION

TO STOP ENGINE (Fig. 6)

- To stop the engine, turn the key to OFF and remove key. Keep key in a safe place. The engine will not start without the key.

TO START ENGINE (Electric Starter) Fig. 6

The snow thrower engine is equipped with a 120 volt AC electric starter and recoil starter. Before starting the engine, be certain that you have read the following information:

COLD START

- Insert the key and turn ON.
- Move the choke control to the FULL position
- Connect the power cord to the switch box on the snow thrower.
- Plug the other end of the power cord into a three hole, grounded 120 volt AC receptacle.
- Push the primer button while covering the vent holes as follows: (Remove finger from primer button between primes).

Do not prime if temperature is above 50°F.

Two times if temperature is 50°F to 15° F.

Four times if temperature is below 15° F.

- Push down on the starter button until the engine starts. Do not crank for more than 10 seconds at a time. This electric starter is thermally protected. If overheated it will stop automatically and can be restarted only when it has cooled to a safe temperature (a wait of about 5 to 10 minutes is required).
- Disconnect the power cord from the receptacle first and then from the switch box on the snow thrower.
- As the engine warms up and begins to operate evenly, move the choke control slowly to the OFF position. If the engine falters, return to 1/2 choke until it runs smoothly, then move to OFF position.

NOTE: Allow engine to warm up for a few minutes before using the snow thrower as the engine will not develop full power until it reaches operating temperature.

WARM START

- Be sure the choke is in the OFF position and pull the starter handle until the engine starts.
- Do not prime a warm engine. If the engine fails to start, follow the Cold Start instructions above

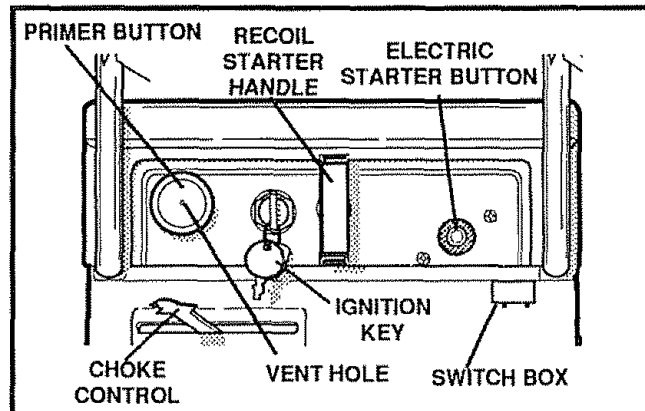

FIG. 6



CAUTION: THIS STARTER IS EQUIPPED WITH A THREE-WIRE POWER CORD AND PLUG AND IS DESIGNED TO OPERATE ON 120 VOLT AC HOUSEHOLD CURRENT. IT MUST BE PROPERLY GROUNDED AT ALL TIMES TO AVOID THE POSSIBILITY OF ELECTRICAL SHOCK WHICH MAY BE INJURIOUS TO OPERATOR. FOLLOW ALL INSTRUCTIONS CAREFULLY AS SET FORTH IN THE "TO START ENGINE" SECTION. DETERMINE THAT YOUR HOUSE WIRING IS A THREE-WIRE GROUNDED SYSTEM. ASK A LICENSED ELECTRICIAN IF YOU ARE NOT SURE. IF YOUR HOUSE WIRE SYSTEM IS NOT A THREE-WIRE SYSTEM, DO NOT USE THIS ELECTRIC STARTER UNDER ANY CONDITIONS. IF YOUR SYSTEM IS GROUNDED AND A THREE-HOLE RECEPTACLE IS NOT AVAILABLE AT THE POINT YOUR STARTER WILL NORMALLY BE USED, ONE SHOULD BE INSTALLED BY A LICENSED ELECTRICIAN. WHEN CONNECTING 120 VOLT AC POWER CORD, ALWAYS CONNECT THE CORD TO THE SWITCH BOX ON THE ENGINE FIRST, THEN PLUG THE OTHER END INTO THE THREE-HOLE GROUNDED RECEPTACLE. WHEN DISCONNECTING POWER CORD, ALWAYS UNPLUG THE END IN THE THREE-HOLE GROUNDED RECEPTACLE FIRST.

TO STOP ENGINE (Fig. 6)

- To stop the engine, turn the key to OFF and remove key. Keep key in a safe place. The engine will not start without the key.

TO START THE ENGINE (Recoil Starter) Fig. 6

Before starting the engine, be certain that you have read and understood all the instructions on the preceding pages.

COLD START

- Insert the key and turn ON.
- Move the choke control to the FULL position.

OPERATION

- Push the primer button while covering the vent holes as follows: (Remove finger from primer button between primes).

Do not prime if temperature is above 50° F.

Two times if temperature is 50° F to 15° F.

Four times if temperature is below 15° F.

- Pull the starter handle with a smooth rapid movement. Do not allow the starter rope to snap back. Rewind smoothly while holding the starter handle. If the engine fires but does not start, pull the starter handle until the engine starts.
- After three pulls, repeat the priming and pulling steps again.
- As the engine warms up and begins to operate evenly, move the choke control slowly to the OFF position. If the engine falters, return to 1/2 choke until it runs smoothly, then move to OFF position.

NOTE: Allow the engine to warm up for a few minutes before using snow thrower, as the engine will not develop full power until it reaches operating temperature.

WARM START

- Be sure the choke is in the OFF position and pull the starter handle until the engine starts.
- Do not prime a warm engine. If the engine fails to start, follow the Cold Engine Start instructions above.



CAUTION: NEVER RUN ENGINE INDOORS OR IN ENCLOSED, POORLY VENTILATED AREAS. ENGINE EXHAUST CONTAINS CARBON MONOXIDE, AN ODORLESS AND DEADLY GAS.

ALWAYS STAND BEHIND SNOW THROWER (OPERATOR'S POSITION) WHEN STARTING ENGINE.

DO NOT PUT HANDS, FEET, HAIR OR LOOSE CLOTHING IN OR NEAR THE DISCHARGE CHUTE DEFLECTOR OR AUGER HOUSING WHILE THE ENGINE IS RUNNING. THE TEMPERATURE OF THE MUFFLER AND NEARBY AREAS MAY EXCEED 150° F.; AVOID THESE AREAS ALSO.



CAUTION: OBJECTS SUCH AS GRAVEL, ROCKS OR OTHER DEBRIS, IF STRUCK BY THE AUGER, MAY BE THROWN WITH SUFFICIENT FORCE TO CAUSE PERSONAL INJURY OR PROPERTY DAMAGE.

SNOW THROWING TIPS

- This snow thrower will propel itself forward when the handle is raised enough to cause the auger blades to contact the ground. The auger should stop when auger control bar is released. If it does not, refer to Adjust Auger Control Cable paragraph on page 14.
- For most efficient snow throwing, turn the discharge chute deflector to throw snow downwind, and slightly overlap each swath. In light snow take up to a full cut and in heavy snow take less than a full cut.
- The distance snow will be discharged can be adjusted by moving the discharge chute deflector. Raise the deflector for more distance or lower the deflector for less distance.
- In windy conditions, lower the chute deflector to direct discharged snow close to the ground where it is less likely to blow into unwanted areas.
- Keep the area to be cleared free of stones, toys and other foreign objects for safety and to prevent damage to the snow thrower.
- Do not use the auger propelling feature when clearing gravel or crushed rock driveways. Move the handle down to raise the auger slightly.
- The allowable forward speed of the snow thrower is dependent on the depth and weight of the snow. Experience will establish the most effective method of using the snow thrower under different conditions.

DRY AND AVERAGE SNOW

- Snow up to eight inch depth can be removed rapidly and easily by walking at a moderate rate. For snow or drifts of a greater depth you may find it desirable to slow your pace to allow the discharge chute to dispose of the snow as rapidly as the auger receives the snow.
- Plan to have the snow discharged in the direction the wind is blowing.

WET PACKED SNOW

- Move slowly into snow of this condition. The greater the depth, the slower you should go. When it appears that the wet, packed snow is causing the auger to slow down and the chute to clog, back off and begin a series of short jabs into the snow. These short back and forth, 4 to 6 inch, jabbing motions will "belch" the snow from the chute.

SNOW BANKS AND DRIFTS

- In snow of greater depth than the unit, use the "jabbing" technique described above. Turn the discharge chute away from the snow bank. More time will be required to remove snow of this type than level snow.

CUSTOMER RESPONSIBILITIES

SERVICE RECORDS Fill in dates as you complete regular service	SCHEDULE					SERVICE DATES			
	Before Each Use	After first 12 Hours	As Needed	Before Storage	Before Each Season				
Tighten All Screws and Nuts		✓	✓						
Check Spark Plug					✓				
Check Drive Belts					✓				
Lubricate Chute Control Flange				✓					
Check Fuel	✓								
Drain Fuel				✓					

GENERAL RECOMMENDATIONS

The warranty on this snow thrower does not cover items that have been subjected to operator abuse or negligence. To receive full value from the warranty, the operator must maintain the snow thrower as instructed in this manual. Some adjustments will need to be made periodically to properly maintain your snow thrower.

All adjustments in the Service and Adjustments section of this manual should be checked at least once each season.

SNOW THROWER

AFTER FIRST USE

- Check for any loose or damaged parts after each use.
- Tighten any loose fasteners.

AFTER EACH USE

- Run the machine to clear the auger of snow.
- Remove all snow and slush from the snow thrower to prevent freezing of auger or controls.

LUBRICATION - AS REQUIRED

- Lubricate the flange on the discharge chute before storage.
- See Lubrication Chart diagram for lubrication points and type of lubricant.

ENGINE

SPARK PLUG

- Clean the spark plug and reset the gap periodically. To service or replace spark plug, see To Replace the Spark Plug paragraph on page 16.
- Make sure that the spark plug is tightened securely into the engine and the spark plug wire is attached to the spark plug.
- If a torque wrench is available, torque plug to 18 to 23 foot pounds.

LUBRICATION CHART

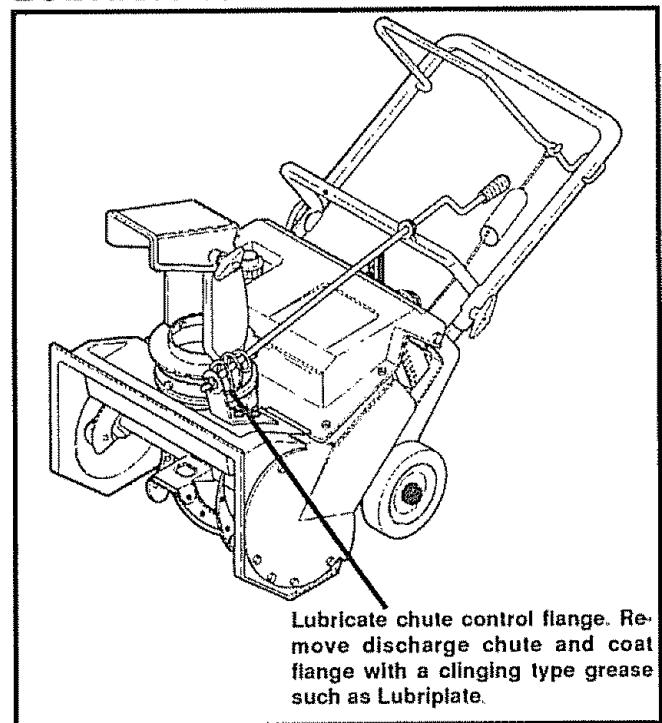

- Clean the area around the spark plug base before removal to prevent dirt from entering the engine.

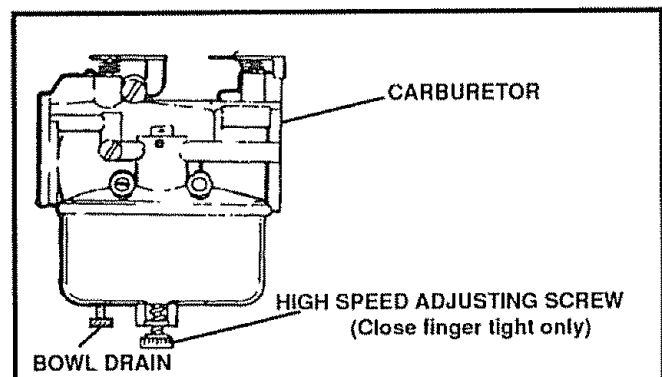

FIG. 7

SERVICE AND ADJUSTMENTS

IMPORTANT: IF YOU THINK THE CARBURETOR IS NOT OPERATING PROPERLY, CONTACT YOUR NEAREST SEARS SERVICE CENTER

CARBURETOR ADJUSTMENT

The carburetor has been pre-set at the factory and readjustment should not be necessary. However, if the carburetor does need to be adjusted, proceed as follows:

- Close high speed adjusting screw by hand. Do not over tighten (See Fig. 7, page 13)
- Open it 1-1/4 to 1-1/2 turns.
- Start the engine and let it warm up.
- Adjust the high speed adjusting screw in (clockwise) until the engine speed or sound alters. Adjust the screw out (counter-clockwise) until the engine speed or sound alters. Note the difference between the two limits and set the screw in the middle of the range.
- If the engine tends to stall under load, adjust the high speed screw out in 1/8 turn increments until the problem is resolved.
- Let the engine run undisturbed for 30 seconds between each setting to allow the engine to react to the previous adjustment

NOTE: On two cycle engines the adjustment must be as far out as possible without resulting in poor engine performance to prevent engine damage.

TO ADJUST THE CHUTE CRANK ASSEMBLY

If you cannot rotate the chute crank fully to the left and to the right, you need to adjust the chute crank (See Fig. 8).

- Loosen both 1/2" nuts on the crank adjusting bracket (using 1/2" wrenches).
- Swivel the crank adjusting bracket to allow about 1/8" clearance between the notch in the flange and the outer diameter of the worm.
- Once this clearance is set, tighten the nuts.

TO ADJUST THE AUGER CONTROL CABLE

The auger control cable is set at the factory for proper operation. If you need to adjust the cable, because the control bar does not properly engage or disengage the auger, do the following:

- Remove "Z" hook from the auger control bar (See Fig. 9).
- Slide the boot toward the loose end of the cable (See Fig. 10A).
- Push the cable down through the hole in the top of the cable adjustment bracket to provide slack in the cable (See Fig. 10B).

- Remove the "Z" hook from the top hole in the cable adjustment bracket and move to the next hole away from the top of the bracket (See Fig. 10B).
- Pull cable slack through cable adjustment bracket and insert in the control bar (See Fig. 10B)
- Replace boot over cable adjustment bracket.
- Insert "Z" hook in the auger control bar.
- Start the snow thrower and check that the auger does not continue to turn when the auger control bar is released.

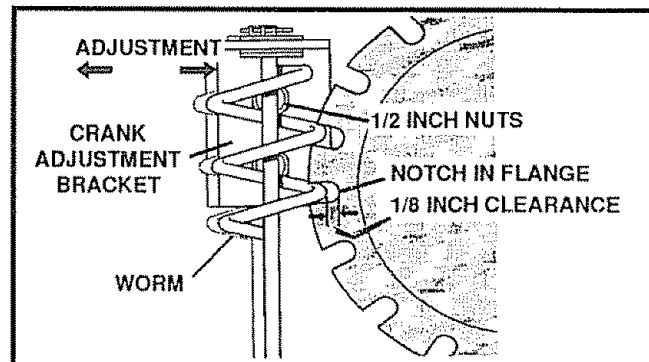

FIG. 8

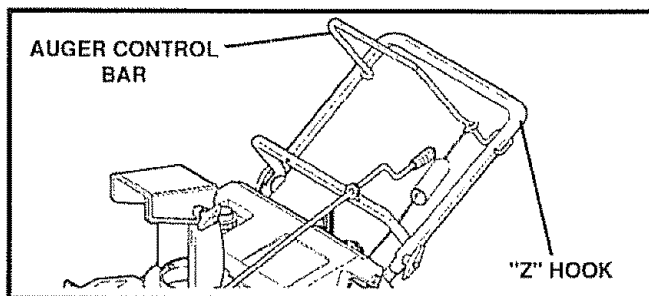

FIG. 9

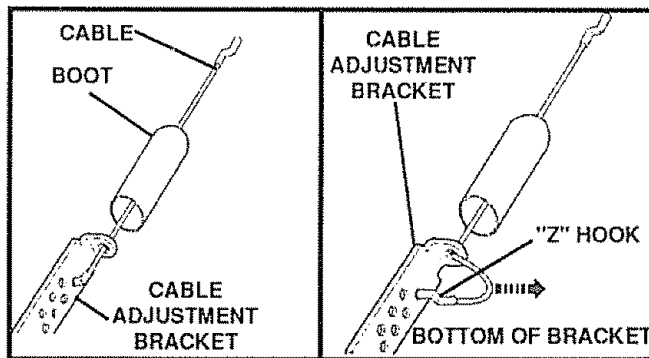

FIG. 10A

FIG. 10B

TO REMOVE BELT COVER

- Remove the belt cover (see Fig. 11, page 15) by removing the 10 screws. There are 5 screws on the front of the belt cover, 1 screw on the bottom of the belt cover, 2 screws on the top cover and 2 screws on the bottom cover (the front screw is shorter than the rear and top screws).
- Pull the belt cover away from the snow thrower.

SERVICE AND ADJUSTMENTS

TO ADJUST THE DRIVE BELT

If the engine drive pulley and the auger drive pulley are not aligned properly, excessive belt wear will occur. To check the pulley alignment, proceed as follows:

- Remove belt cover (see To Remove Belt Cover on page 14).
- Place a straight edge approximately 16" long across the large auger pulley, touching two points and extending to the engine pulley (See Fig. 12A). The outside of the engine pulley must be flush with the straight edge. If the pulleys are aligned, skip to the last step (See Fig. 11).

To adjust the engine pulley:

- Loosen the 2 set screws on the engine pulley.
- Slide the engine pulley in or out on the shaft until the pulley is flush with the straight edge.
- Tighten the 2 set screws on the engine pulley.
- Reinstall the belt cover.

If the drive belt is damaged or worn excessively, replace it with a new belt.

TO REPLACE THE DRIVE BELT

The drive belt on this unit is of special construction and must be replaced with the same type belt available at your nearest Sears Service Center.

- Remove the belt cover (See to Remove the Belt Cover paragraph on page 14).
- Move belt guide away from belt (See Fig. 12).
(Belt may come out without loosening belt guide.)
- Carefully press idler pulley down to release brake pressure on belt.
- Remove belt from between brake pad and roller.
- Remove old belt.
- Replace with new belt by carefully pressing down on the idler pulley and placing the belt between the brake pad and roller with belt ribs down.
- Release belt pulley.
- Attach new belt to the engine pulley and auger pulley.
- Make sure the belt is seated properly.
- Move belt guide into position. (The belt guide should be 3/32" from belt when belt is engaged as shown in Fig. 12B, page 16).
- Check the drive belt adjustment (See to Adjust the Drive Belt paragraph above).
- Reinstall belt cover. Make sure the shorter screw is in the front position (see Fig. 11).

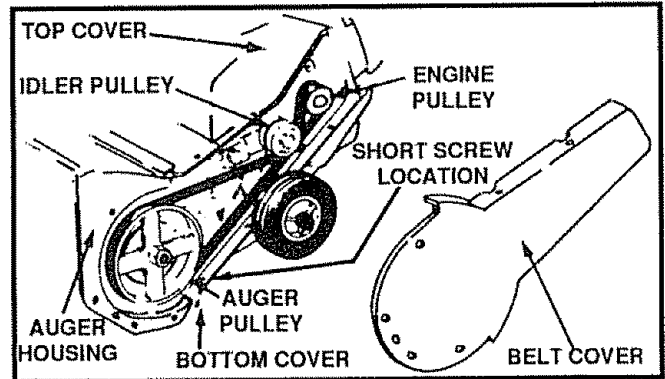

FIG. 11

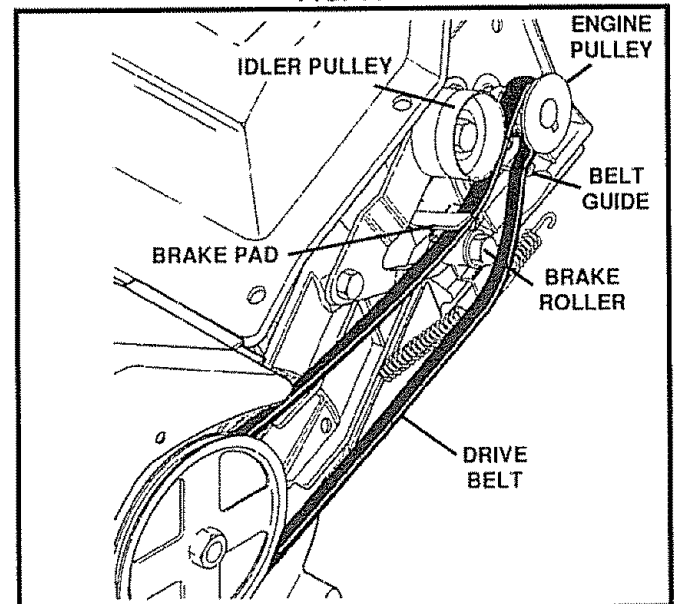

FIG. 12

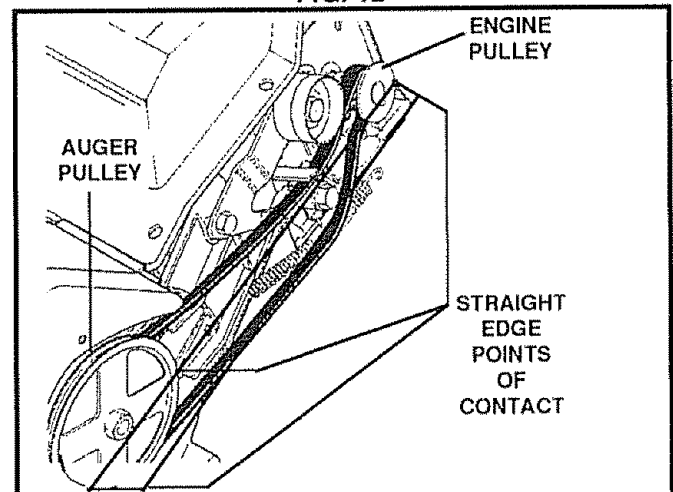

FIG. 12A

SERVICE AND ADJUSTMENTS

TO REPLACE THE AUGER

- Remove the belt cover (See To Remove Belt Cover paragraph on page 14) and the drive belt. See the Drive Belt Replacement paragraph on page 15.
- Remove the auger pulley (See Fig. 13) from the auger shaft (threads are left hand; turn clockwise to remove). Place a piece of wood (2x4) on the center paddle area to secure auger to keep from turning.
- Remove the bearing assembly from the left frame of snow thrower by removing the two nuts (See Fig. 13).
- Slide the auger assembly out of the bearing assembly on the right side of the snow thrower.
- Tip the auger assembly enough to allow it to slide out of the auger housing.
- Install the new auger assembly in reverse order of removal.

NOTE: Check the drive belt adjustment before reinstalling the belt cover (see To Adjust the Drive Belt paragraph on page 15).

TO REPLACE THE SPARK PLUG

The spark plug is housed in the engine compartment under the top cover (See Fig. 14) and cannot be seen under normal conditions.

- Remove the 5 screws from the top cover. Remove the cover.
- Remove the spark plug wire.
- Clean the area around the plug base to prevent dirt from entering the engine when the plug is removed.
- Remove the spark plug. If it is cracked, fouled or dirty, it must be replaced (see page 4 for the proper replacement plug).
- Set the gap between the electrodes of the new spark plug at .030 inch. Next, install the spark plug in the cylinder head. Torque plug to 18 to 20 ft. lb. If you do not use a torque wrench, tighten the plug firmly (See Fig. 15).
- Push the spark plug wire onto the spark plug.
- Reinstall the top cover.

ENGINE SERVICE

Unless the operator is fully qualified to make engine repairs or adjustments, we recommend that such work should be done by technicians trained to work on snow thrower type engines. Take your snow thrower to your nearest Sears Service Center for repair and adjustment.

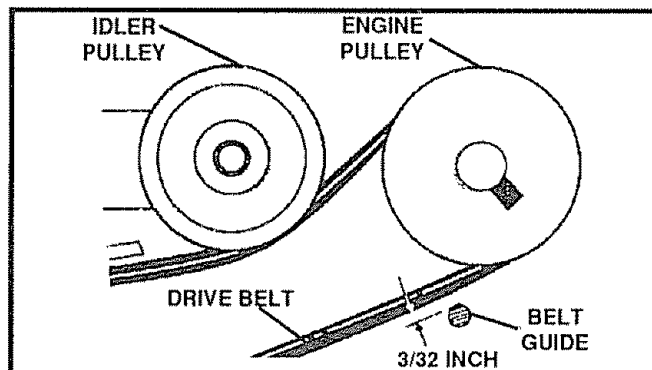

FIG. 12B

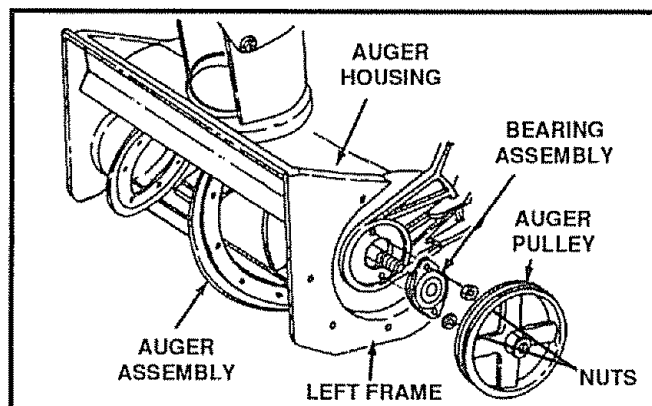

FIG. 13

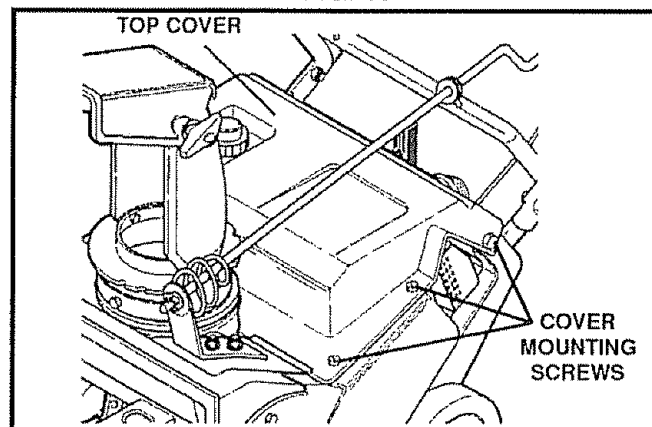

FIG. 14

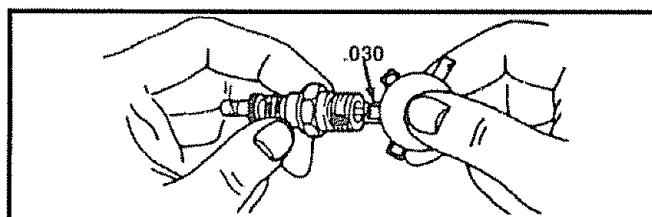

FIG. 15

ADJUST ENGINE SPEED

Your engine speed has been factory set. Do not attempt to change engine speed or it may result in personal injury. If you believe that the engine is running too fast or too slow, take your snow thrower to your nearest Sears Service Center for repair and adjustment.

STORAGE



CAUTION: NEVER STORE YOUR SNOW THROWER INDOORS OR IN AN ENCLOSED, POORLY VENTILATED AREA IF GASOLINE REMAINS IN THE TANK. FUMES MAY REACH AN OPEN FLAME, SPARK OR PILOT LIGHT FROM A FURNACE, WATER HEATER, CLOTHES DRYER, CIGARETTE, ETC.

To prevent engine damage (if snow thrower is not used for more than 30 days) follow the steps below.

SNOW THROWER STORAGE

- Thoroughly clean the snow thrower.
- Lubricate all the lubrication points (see the Customer Responsibilities section, page 13).
- Be sure that all nuts, bolts and screws are securely fastened. Inspect all visible moving parts for damage, breakage and wear. Replace if necessary.
- Touch up all rusted or chipped paint surfaces; sand lightly before painting.
- Cover the bare metal parts of the blower housing and auger with rust preventative, such as a spray lubricant.

ENGINE STORAGE

Gasoline must be removed or treated to prevent gum deposits from forming in the tank, filter, hose, and carburetor during storage. Also during storage, alcohol blended gasoline that uses ethanol or methanol (sometimes called gasohol) attracts water. It acts on the gasoline to form acids which damage the engine.

- To remove gasoline, run the engine until the tank is empty and the engine stops. Then drain remaining gasoline from carburetor by pressing upward on bowl drain located on the bottom of carburetor (See Fig. 16).
- If you do not want to remove gasoline, a fuel stabilizer (such as Craftsman fuel stabilizer No. 33500) may be added to any gasoline left in the tank to minimize gum deposits and acids. If the tank is almost empty, mix stabilizer with fresh gasoline in a separate container and add some to the tank. **ALWAYS FOLLOW INSTRUCTIONS ON STABILIZER CONTAINER. THEN RUN ENGINE AT LEAST 10 MINUTES AFTER STABILIZER IS ADDED TO ALLOW MIXTURE TO REACH CARBURETOR. STORE SNOW THROWER IN A SAFE PLACE. SEE WARNING ABOVE.**

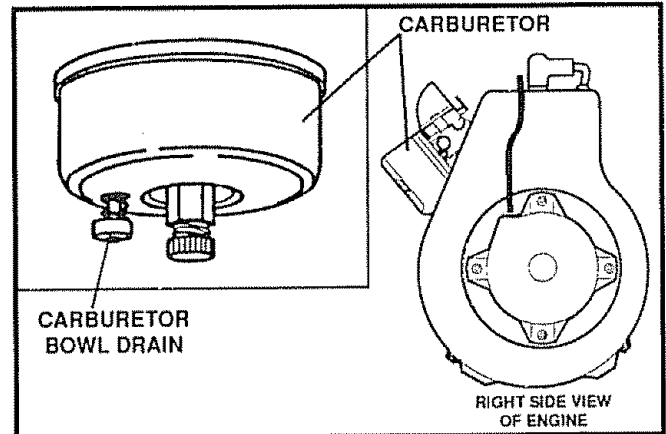

FIG. 16

You can keep your engine in good operating condition during storage by:

- Lubricating the piston/cylinder area. This can be done by first removing the spark plug and squirting a few drops of clean engine oil into the spark plug hole. Then cover the spark plug hole with a rag to absorb oil spray. Next, rotate the engine by pulling the starter rope fully out two or three times. Finally, reinstall spark plug and attach spark plug wire.

OTHER

- If possible, store your snow thrower indoors with the gas removed and cover it to give protection from dust and dirt.
- If the machine must be stored outdoors, block up the snow thrower to be sure the entire machine is off the ground.
- Cover the snow thrower with a suitable protective cover that does not retain moisture. Do not use plastic or vinyl.

NOTE: A yearly checkup or tune-up at a Sears Service Center is a good way of ensuring that your snow thrower will provide maximum performance for the next season.

TROUBLE SHOOTING POINTS

TROUBLE	CAUSE	CORRECTION
Difficult starting	Defective spark plug	Replace defective plug
Engine stalls	Unit running on CHOKE	Move choke lever to OFF position
Engine runs erratically; or Loss of power	Blocked fuel line or low on fuel	Clean fuel line; check fuel supply; add fresh gasoline (gasoline/oil mixture if 2 cycle engine)
	Water or dirt in fuel system	Use carburetor bowl drain to flush and refill with fresh fuel
	Carburetor out of adjustment	See carburetor adjustment section on page 14
Excessive vibration	Loose parts; damaged impeller	Stop engine immediately and disconnect spark plug wire Tighten all bolts and make all necessary repairs. If vibration continues, have the unit serviced by a competent repairman
	Damaged auger	Repair or replace auger assembly
Unit fails to propel itself	Drive belt loose or damaged	Replace drive belt
	Incorrect adjustment of auger control cable	Adjust auger control cable
Unit fails to discharge snow	Auger drive belt loose or damaged	Adjust auger drive belt; replace if damaged
	Auger control cable not adjusted correctly	Adjust auger control cable
	Discharge chute clogged	Stop engine immediately and disconnect spark plug wire Clean discharge chute and inside of auger housing
	Foreign object lodged in auger	Stop engine immediately and disconnect spark plug wire. Remove object from auger

NOTES