



SCHWINN FITNESS

SR23
RECUMBENT
ASSEMBLY GUIDE



Table of Contents

Hardware	2
Exploded View	4
Parts List	5
Assembly Instructions	6

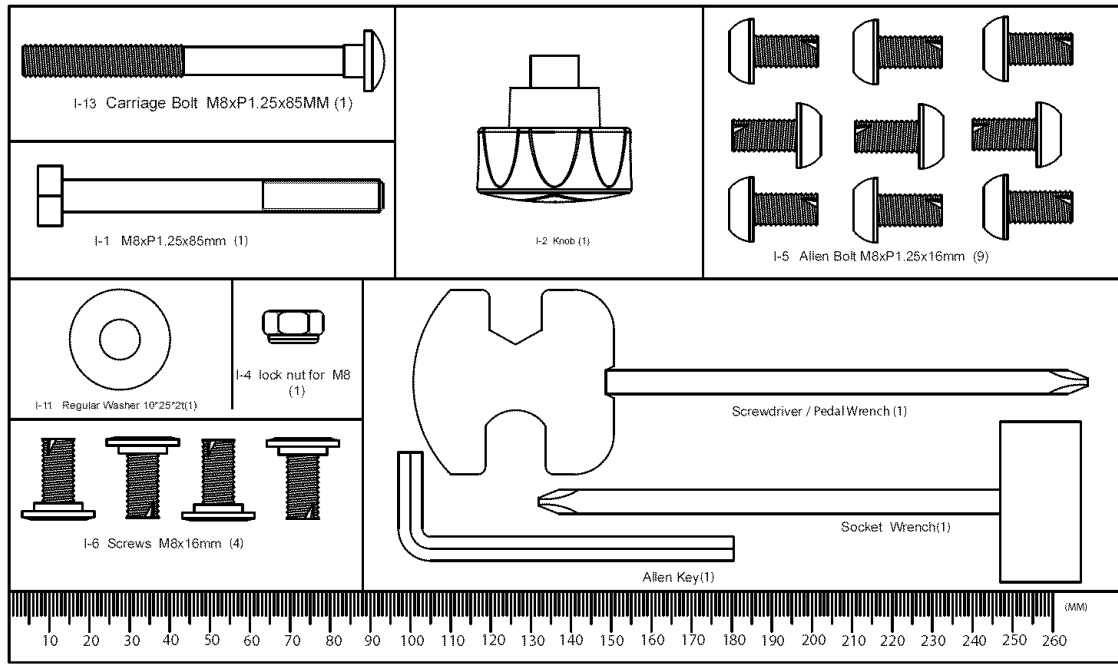

Note: Please verify you have all correct parts and quantities before assembling unit.

If you are missing items, are short quantities, or have damaged components, please contact Schwinn at 1.800.864.1270

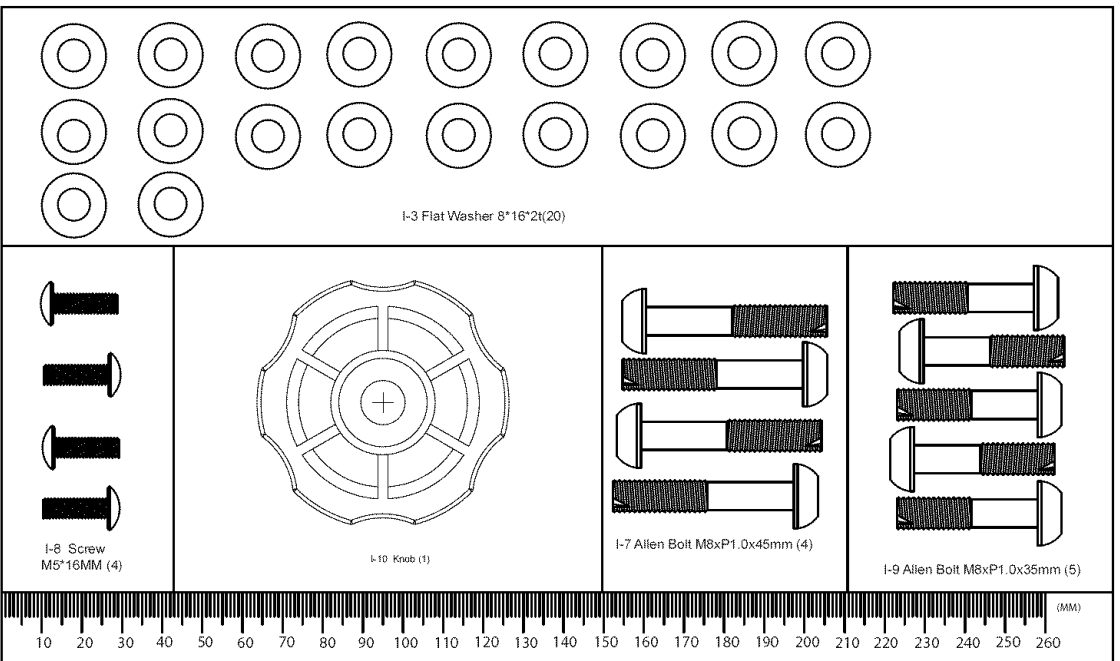

Note: Please verify you have all correct parts and quantities before assembling unit.
 If you are missing items, are short quantities, or have damaged components, please contact Schwinn at 1.800.884.1270

EXPLODED VIEW

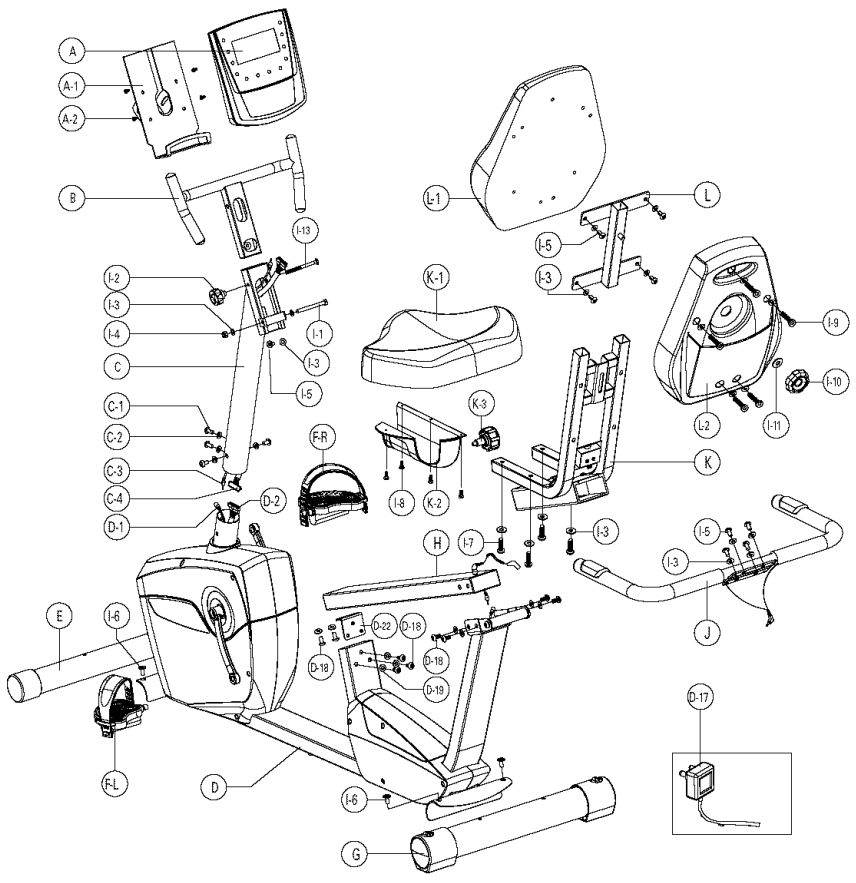

PARTS LIST

Ref.	Description	Qty
A	Computer	1
A-1	Computer bracket	1
A-2	Screw M5x14L	4
B	Handlebar	1
C	Handlebar mast	1
C-1	Screw M8x1.25x16	4
C-2	Curved washer	4
C-3	Upper heart rate wire	1
C-4	Upper computer wire	1
D	Main frame	1
D-1	Lower heart rate wire	1
D-2	Lower computer wire	1
D-17	AC adaptor	1
D-18	Screw M8x1.25x16L	9
D-19	Flat washer 8x16	11
D-22	Seat rail bracket	1
E	Front stabilizer	1
F	Pedal pair	1
G	Rear stabilizer	1
H	Seat rail	1
I-1	Screw M8xP1.25x85L	1
I-2	Angle adjust knob	1
I-3	Flat washer 8x16x2t	20
I-4	Nylon nut	1
I-5	Screw M8x16	9
I-6	Screw M8x16 Flat	4
I-7	Screw M8x1x45	4
I-8	Screw M5x16	4
I-9	Screw M8x35	5
I-10	Seat adjust knob	1
I-11	Flat washer 10x25x2t	1
I-13	Carriage Bolt M8x1.25x85	1
J	Seat handlebar	1
K	Seat frame	1
K-1	Seat bottom	1
K-2	Water bottle holder	1
K-3	Seat adjustment knob	1
L	Seat bracket	1
L-1	Seat back	1
L-2	Seat back cover w/ magazine Holder	1

Basic Assembly Principles

Here are a few basic tips that will aid in the assembly process . By using these principles, you can simplify each process and save yourself extra time and effort.

1. To make the assembly process go faster, gather the pieces you need for each step and thoroughly read the assembly instructions for that step prior to starting assembly for the step.
2. When attaching two pieces, gently lift and look through the bolt holes to help guide the bolt through the holes.
3. As a general rule, and for all bolts and nuts, turn bolts or nuts toward the right to tighten and left to loosen. Or you can remember the mnemonic: "Righty tighty, lefty loosey."

Step 1 Install Front and Rear Stabilizers

Parts:

- Main frame (Ref. D)
- Front Stabilizer (Ref. E)
- Rear Stabilizer (Ref. G)
- M8x16 Screws (Ref. I-6)

Tools:

- Supplied Allen Wrench

1-1 Attach the Rear Stabilizer (G) to the rear of the Main Frame using two M8 X 16mm screws (I-6).

1-2 Attach the Front Stabilizer (E) with the UP sticker and wheels toward the front of the Main Frame using two M8 X 16mm screws.

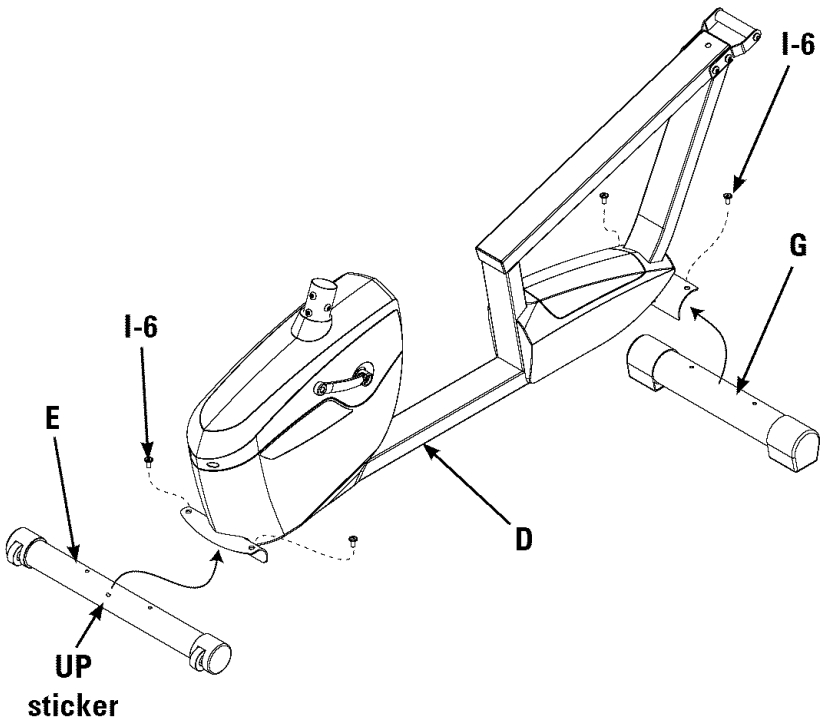

Step 2 Install Pedals

Parts:

- Right Pedal (F-R)
- Left Pedal (F-L)

Tools:

- Supplied Pedal Wrench

2-1 Screw the Left Pedal (has an " L " stamped into the end of the pedal) into the Left Crank Arm.

Note: The Left Pedal has a left handed thread and screws in counter clockwise.

2-2 Screw the Right Pedal (has an " R " stamped into the end of the pedal) into the Right Crank Arm.

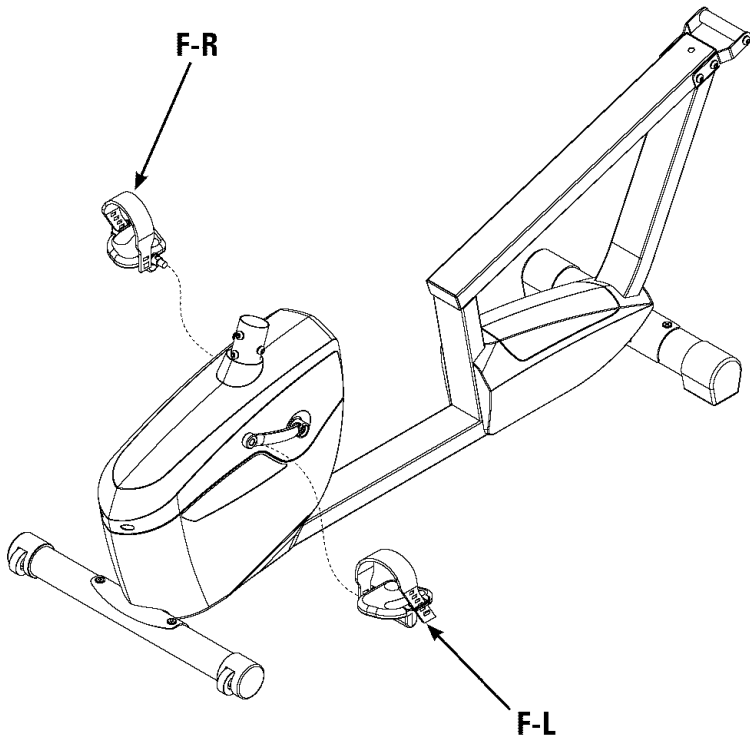

Step 3 Install Handlebar

Parts:

- Seat Frame (Ref. K)
- Handlebar (Ref. J)
- Four M8x16 screws (Ref. I-5)
- Four 8x16x2 Washers (Ref. I-3)

Tools:

- Supplied Allen Wrench

3-1 Align Handlebar with holes in Seat Frame.

3-2 Route the handlebar heart rate wire under the junction box making sure that the wires won't be pinched. Connect the handlebar heart rate wire to the jack on the Seat Frame junction box labeled "PULSE INPUT".

3-3 Install and completely tighten the hardware.

NOTE: Be careful not to pinch the wires when tightening the hardware.

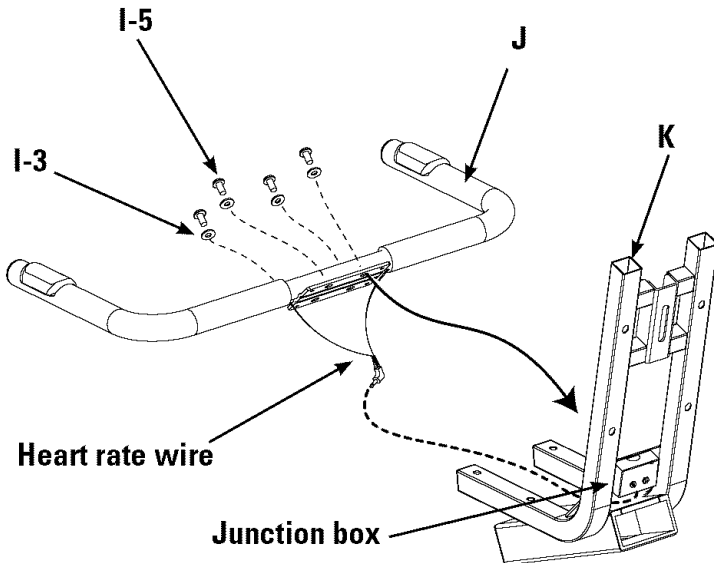

Step 4 Install Bottle Holder

Parts:

- Water Bottle Holder (Ref. K-2)
- Four M5x16 Screws (Ref. I-8)
- Seat Bottom (Ref. K-1)

Tools:

- Supplied Phillips Head Screwdriver

4-1 Align the Water Bottle Holder under the left side of the Seat Bottom.

4-2 Install and completely tighten the hardware.

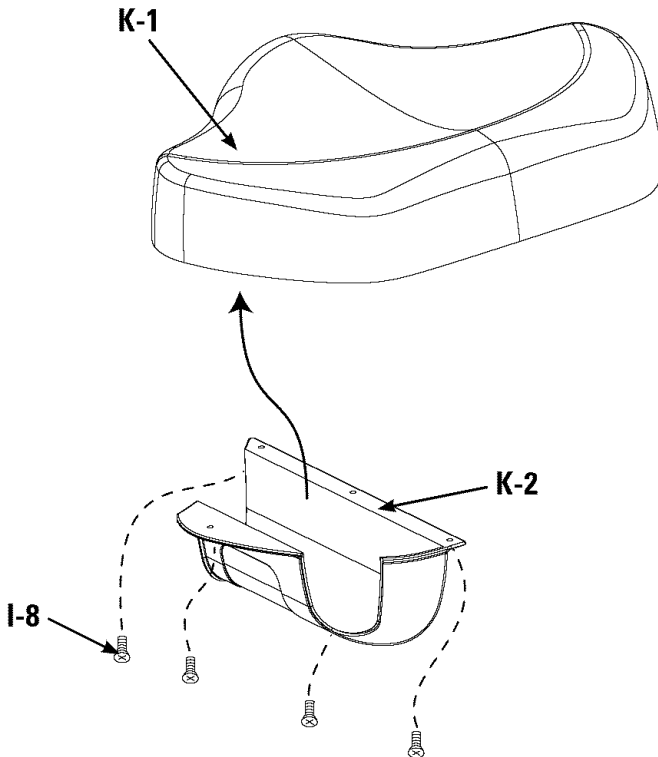

Step 5 Install Seat Bottom

Parts:

- Seat Bottom (Ref. K-1)
- Four M8x1x45 Screws (Ref. I-7)
- Four 8x16x2 Washers (Ref. I-3)

Tools:

- Supplied Allen Wrench

5-1 Align the Seat Bottom (K-1) with the Seat Frame (K).

5-2 Install and completely tighten the hardware.

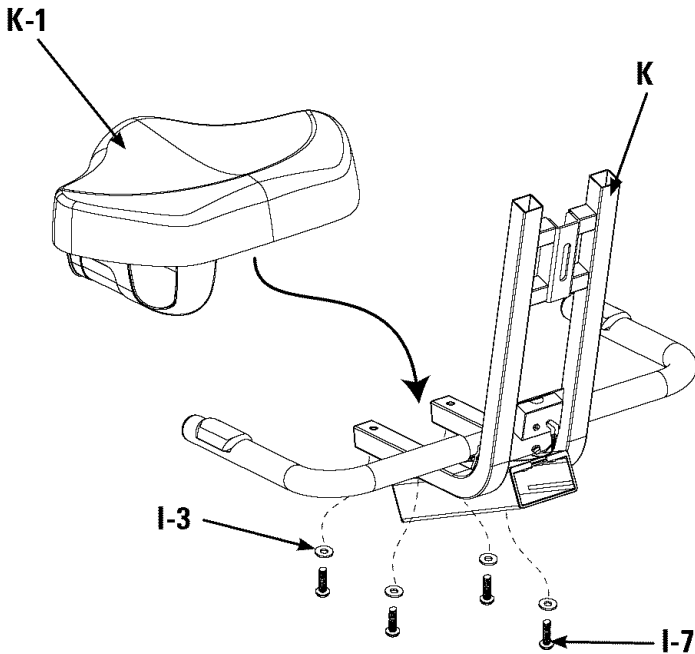

Step 6 Install Seat bracket

Parts:

- Seat Bracket (Ref. L)
- Seat Back (Ref L-1)
- Four M8x16 Screws (Ref. I-5)
- Four 8x16x2 Washers (Ref. I-3)

Tools:

- Supplied Allen Wrench

6-1 Align the Seat Bracket(L) with the Seat Back (L-1).

6-2 Install and completely tighten the hardware.

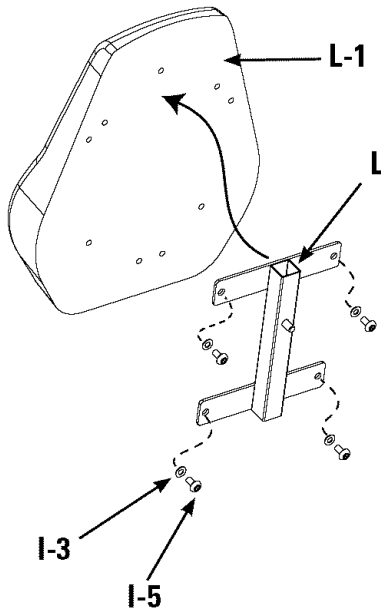

Step 7 Install Seat Back Assy and Seat Back Cover

Parts:

- Seat Back Cover (Ref. L-2)
- Seat Back Assy (From step 5)
- Five M8x35 Screws (Ref. I-9)
- Five 8x16x2 Washers (Ref. I-3)
- Seat Adjust Knob (Ref. I-10)
- Washer 10x25x2t (Ref. I-11)

Tools:

- Supplied Allen Wrench

7-1 Place the threaded post on the Seat Bracket (L) through the slot in the Seat Frame (K).

7-2 Attach the Seat Back Cover to the Seat Back Assembly using five M8x35 Screws (I-9) and five 8x16x2 Washers (I-3).

7-3 Install the Seat Adjust Knob (I-10) and washer 10x25x2t (I-11) onto the threaded post.

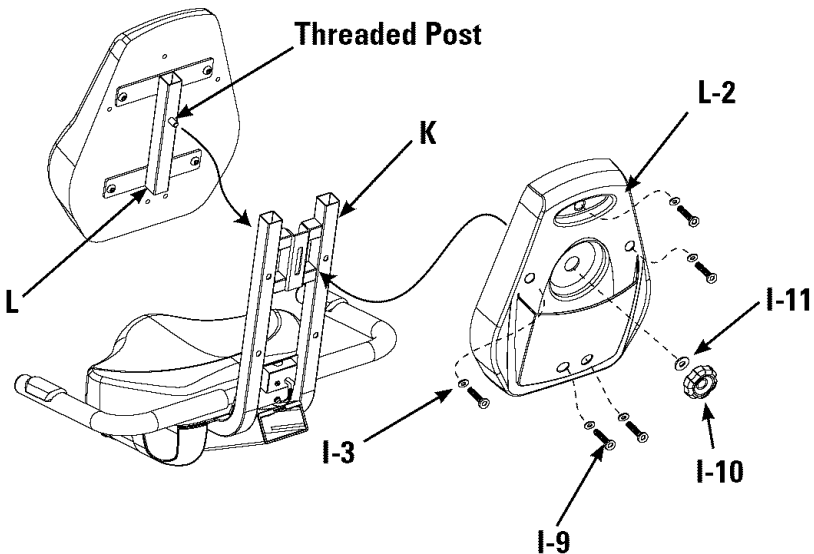

Step 8 Prepare to Install Seat Assembly

Tools:

- Supplied Allen Wrench

8-1 Unscrew the seven screws and washers (D-18) that secure the Seat Rail (H) and remove the Seat Rail from the unit. (Figure A)

Note: You will have to disconnect the Heart Rate Wire (M).
Do not let the Heart Rate Wire fall into the frame.

8-2 Unscrew the two screws and washers (D-18) that secure the Seat Rail Bracket (D-22) and remove the bracket from the Seat Rail. (Figure B)

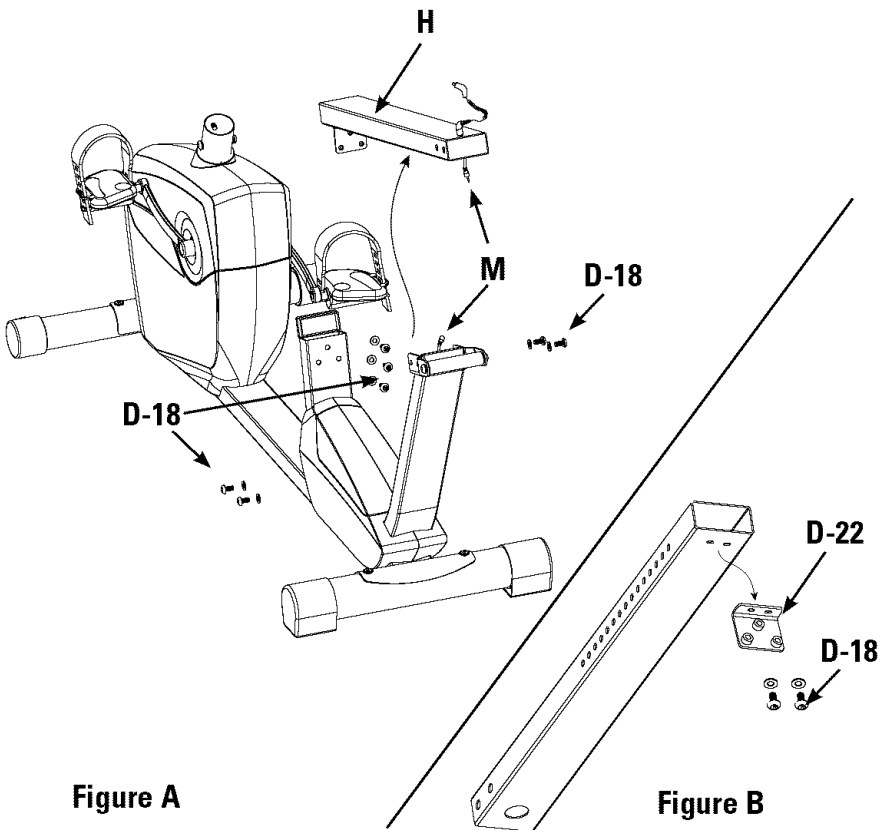

Step 9 Install Seat Assembly

Parts:

- Seat Assembly (From Steps 3 through 7)
- Seat Rail (Ref. H)
- Seat Rail Bracket (Ref. D-22)

Tools:

- Supplied Allen Wrench

NOTE: To ease assembly, use two people for this step.

- 9-1** Pull out on the Seat Adjustment Knob (K-3) while sliding the Seat Assembly onto the Seat Rail (H). Release the Adjustment Knob to lock the Seat Assembly in place.

NOTE: Make sure the seat Adjustment Knob is on the side of the Seat Rail that has the holes.

- 9-2** Reinstall the Seat Rail Bracket to the Seat Rail making sure the Tab of the Bracket faces forward.

- 9-3** Reconnect the Heart Rate Wires and reinstall the Seat Rail with Seat Assembly on the main unit. (Figure A)

NOTE: After reconnecting the Heart Rate Wires, tuck them into the hole in the frame to avoid pinching the wires.

- 9-4** Connect the Heart Rate Wire (M) to the jack on the junction box labeled "HAND PULSE". (Figure B)

NOTE: To access the Junction Box you may have to loosen the knob on the Seat Back, raise it upward then re-tighten the knob. This also how you adjust the Seat Back to position the lumbar support to your preference.

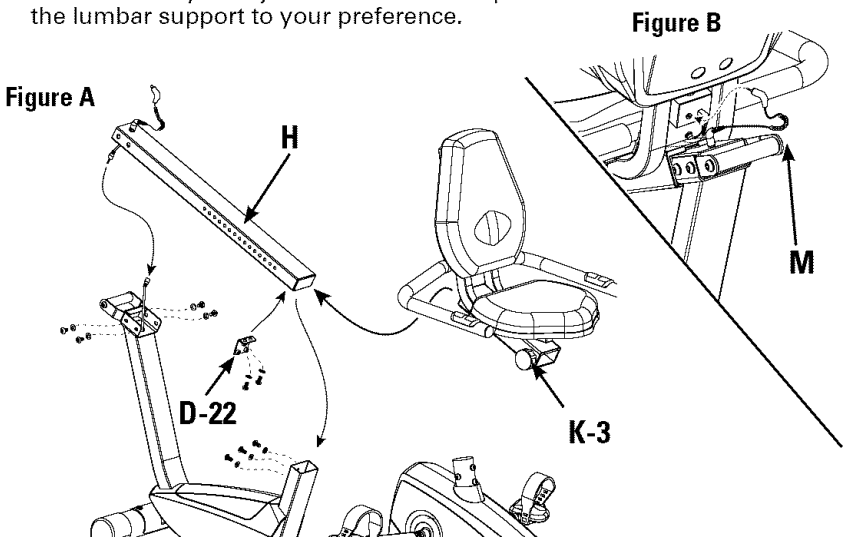

Step 10 Install Handlebar Mast

Parts:

- Handlebar Mast (Ref C)

Tools:

- Supplied Allen Wrench

10-1 Remove the four Allen Bolts (C-1) and Curved Washers (C-2) from the frame .

10-2 Connect the Upper and Lower Computer Wires and Heart Rate Wires. (Detail A)

10-3 Insert the Handlebar Mast (C) into the main unit.

10-4 Re-install the four Allen Bolts and Curved Washers and completely tighten.

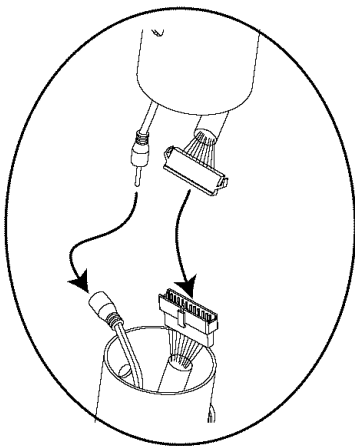

Detail A

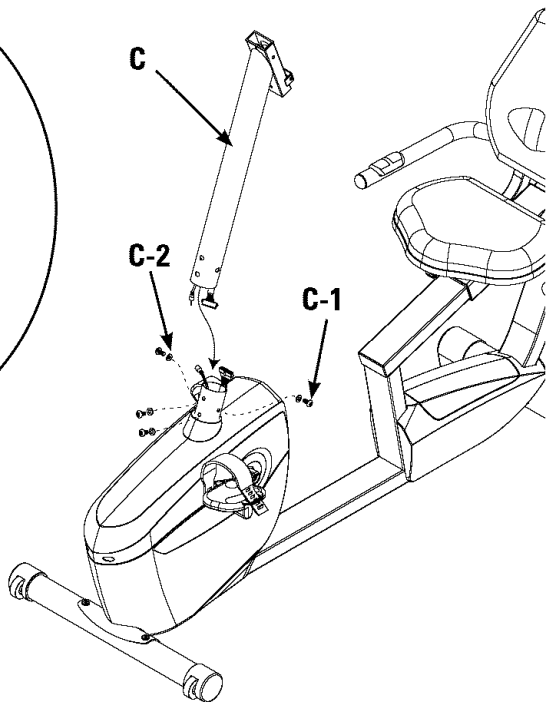

Step 11 Install Handlebar

Parts:

- Handlebar (Ref B)
- Washer (Ref I-3)
- Screw M8x16 (Ref I-5)

11-1 Tuck the Computer Wires into the Mast to allow insertion of the Handlebar .

11-2 Slide the Handlebar (B) into the Mast and secure with the Console M8x16 Screw (I-5) and Washer (I-3) . (Figure A)

11-3 Pull the Computer Wires back up through the Handlebar as shown. (Figure B)

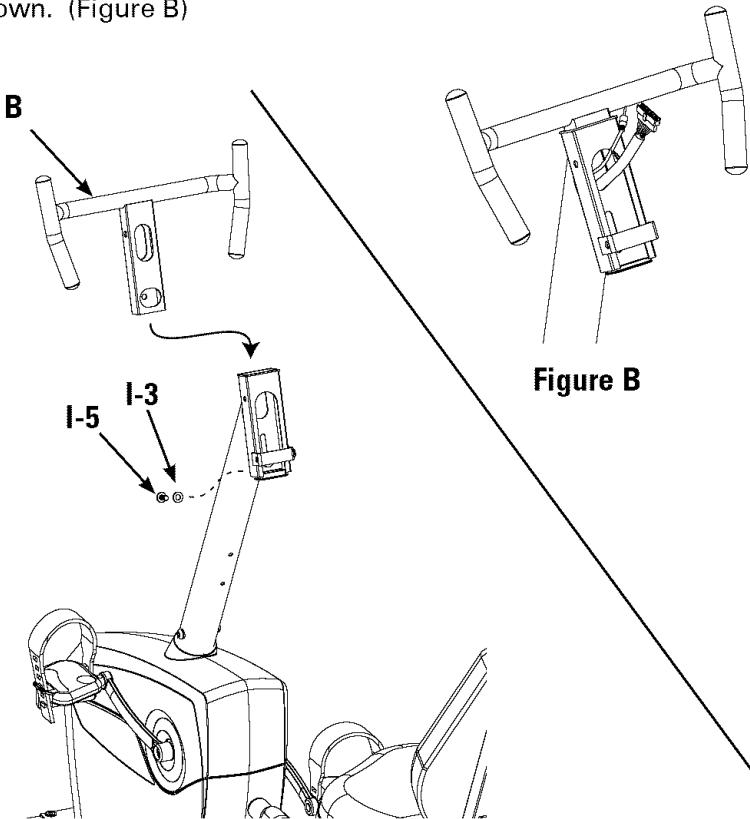

Figure A

Figure B

Step 12 Install Computer Bracket

Parts:

- Computer Bracket (Ref. A-1)
- Angle Adjust Knob (Ref. I-2)
- Carriage Bolt M8x1.25x85 (Ref. I-13)
- Screw M8x85 (Ref. I-1)
- 2 Washers (Ref. I-3)
- Hex Nut (Ref. I-4)

Tools:

- Supplied Socket and Flat Wrenches

12-1 Align the Computer Bracket (A-1) with the holes in the Mast.
(See assembled view for reference)

12-2 Install and completely tighten the hardware.

Note: Use the Angle Adjust Knob to position the Computer to fit individual preferences.

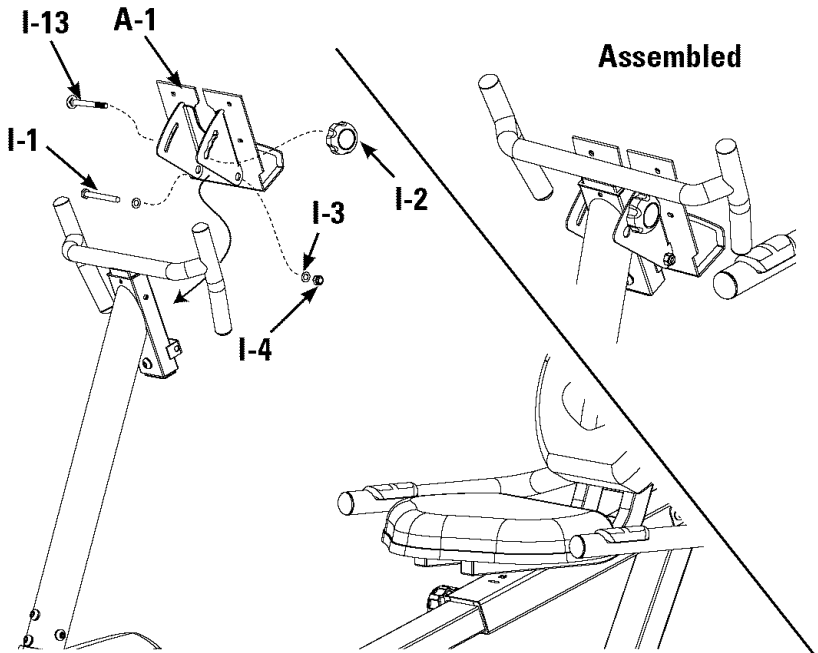

Step 13 Install Computer

Parts:

- Computer (Ref. A)

Tools:

- Supplied Phillips Head Screwdriver

13-1 Remove the four screws from the back of the Computer.

13-2 Connect the Computer Wire and Heartrate Wire to the connectors on the back of the Computer as shown.

13-3 Align the Computer with the holes in the Computer Bracket.
(A-1)

13-4 Install and completely tighten the hardware.

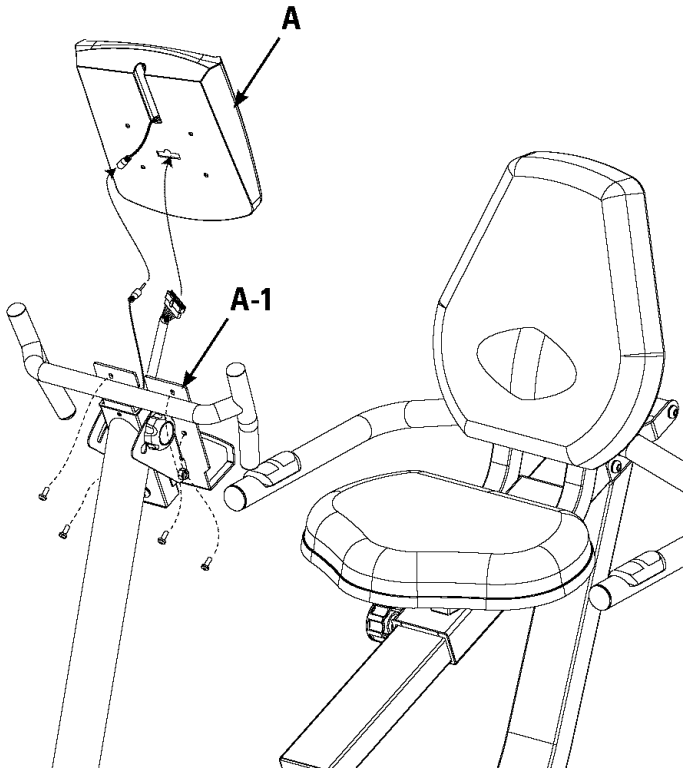

Step 14 Plug in AC Adapter

Parts:

- AC Adapter (Ref. D-17)

14-1 Plug the AC Adapter (P) into the receptacle on the front right of the unit and into a 110 volt outlet.

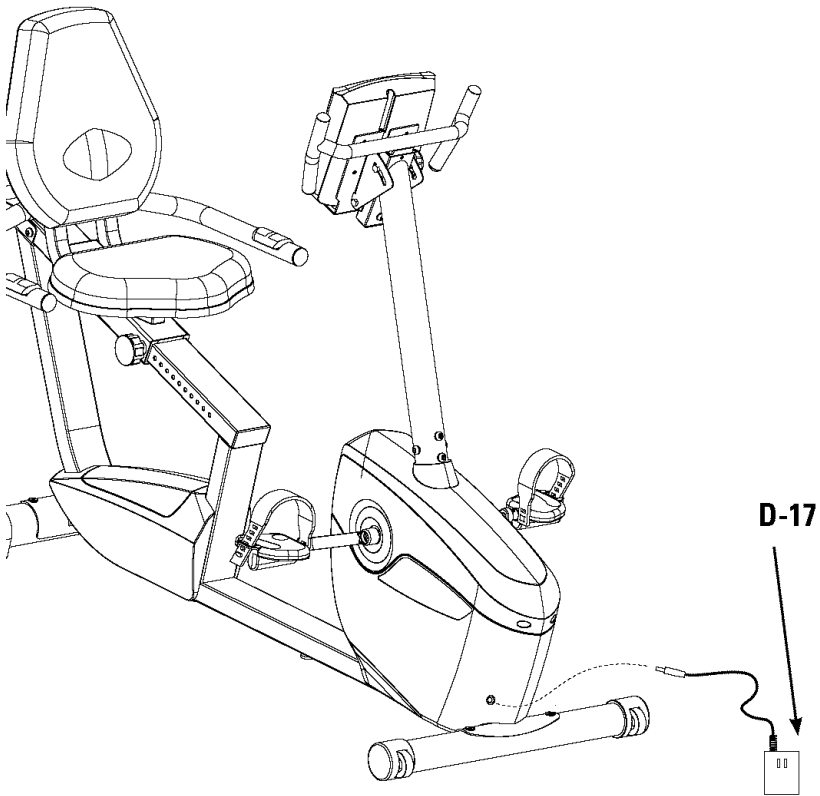

Assembly is complete!

Please reference the Owner's Manual for information regarding computer operation, product maintenance, Warranty information, and general fitness and exercise guidelines.

If you need assistance, please refer to your owners manual for warranty and contact information.

