



Model • Modèle • Modelo
DWC512BL

For service, contact
your nearest service depot or call:
1-800-26D-anby
to recommend a depot in
your area.

Pour obtenir le service, consultez
votre succursale régionale de
service ou téléphonez:
1-800-26D-anby
qui vous recommandera un
centre régional.

Para servicio, comuníquese con
su departamento de servicios más
cercano o llame al:
1-800-26D-anby
para que le recomienden un
departamento de servicios
en su zona.

DELUXE WINE COOLER

The model number of your wine cooler is found on the serial plate located on the back, top left-hand corner of the refrigerator.

All repair parts available for purchase or special order when you visit your nearest service depot. To request service and/or the location of the service depot nearest you, call the toll free number listed to the left in Canada and the U.S.

When requesting service or ordering parts, always provide the following information:

- Product Type
- Model Number
- Part Number
- Part Description

REFROIDISSEUR DE VIN

Le numéro de modèle de votre refroidisseur de vin se trouve sur la plaque d'identification qui se trouve sur le coin du haut gauche de l'arrière du réfrigérateur.

Toutes les pièces de rechange sont disponibles immédiatement ou peuvent être commandées de votre Centre de Service régional. Pour obtenir le service et/ou le Centre de Service le plus proche, téléphonez le numéro sans-frais indiqué à gauche pour le Canada et les États-Unis.

Ayez les informations suivantes à la portée de la main lors de la commande de pièces ou service:

- Genre de produit
- Numéro de modèle
- Numéro de pièce
- Description de la pièce

REFRIGERADOR PARA VINOS

El número del modelo de su refrigerador para vinos se encuentra en la placa de serie ubicada en el ángulo posterior superior izquierdo del refrigerador.

Todas las piezas de repuesto se encuentran disponibles para la compra o por pedido especial cuando Ud. visite su departamento de servicio más cercano. Para solicitar servicio y/o la ubicación del departamento de servicio más cercano, llame al número de marcando gratis que aparece a la izquierda en el Canadá y en los E.U.

Cuando solicite servicio o encargue repuestos, siempre proporcione la siguiente información:

- Tipo de producto
- Número de modelo
- Número del repuesto
- Descripción del repuesto

Danby Products Limited, PO Box 1778, Ontario, Canada N1H 6Z9
Danby Products Inc., PO Box 669, Findlay, Ohio, USA 45839-0669



**OWNER'S MANUAL
MANUEL D'UTILISATION
MANUAL DEL PROPIETARIO**

**Model • Modèle • Modelo
DWC512BL**

CAUTION:

Read and follow all safety rules and operating instructions before first use of this product.

PRÉCAUTION:

Veuillez lire attentivement les consignes de sécurité et les instructions d'utilisation avant l'utilisation initiale de ce produit.

PRECAUCIÓN:

Lea y observe todas las reglas de seguridad y las instrucciones de operación antes de usar este producto por primera vez.

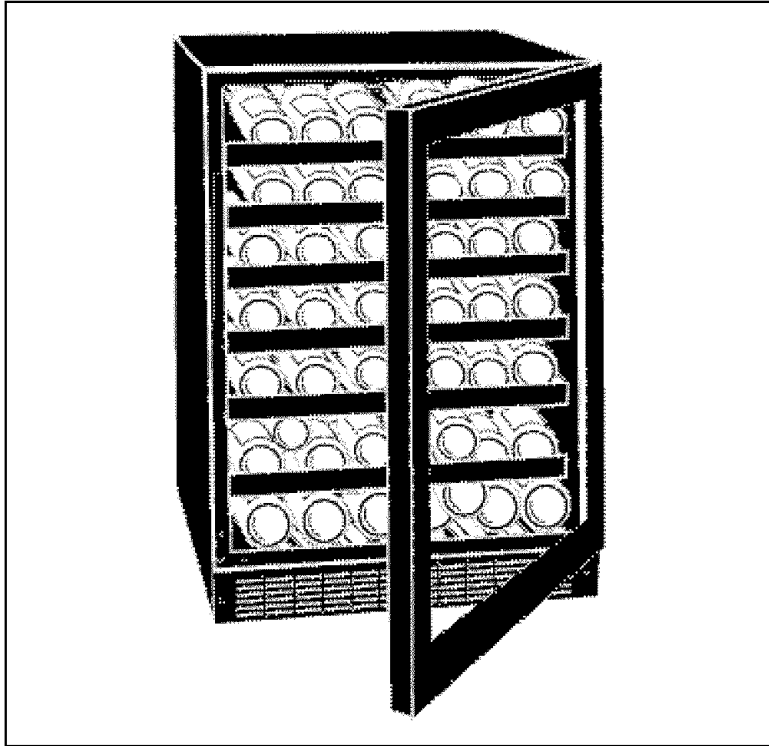

DELUXE WINE COOLER

Owner's Manual1-5

- Safety Instructions
- Installation
- Operation
- Care and Maintenance

REFROIDISSEUR DE VIN

Manuel d'utilisation6-10

- Consignes de sécurité
- Installation
- Fonctionnement
- Soins et entretien

REFRIGERADOR PARA VINOS

Manual del propietario11-15

- Instrucciones de seguridad
- Instalación
- Operación
- Cuidado y Mantenimiento



LIMITED PRODUCT WARRANTY

This quality product is warranted to be free from manufacturer's defects in material and workmanship, provided that the unit is used under the normal operating conditions intended by the manufacturer.

This warranty is available only to the person to whom the unit was originally sold by Danby or by an authorized distributor of Danby, and is non-transferable.

TERMS OF WARRANTY

Plastic parts (ie. evaporator door, door rails, covers and trays are warranted for thirty (30) days only from purchase date, with no extensions provided.

2 Years During the first two years (2), any electrical parts of this product found to be defective, including any sealed system units, will be repaired or replaced, at warrantor's option, at no charge to the ORIGINAL purchaser. Consumable parts (ie. light bulbs) are not warranted or guaranteed for any length of time.

Third Through Fifth Year During the next three years (3) any part of the sealed system found to be defective (consisting of compressor, condenser, evaporator, dryer and all related tubing) will be replaced without charge. The purchaser shall pay for all labour and return freight during this three year (3) period for repair or replacement of any sealed system components. Any unit being diagnosed as non-functional due to sealed system failure and warranting an exchange during the existing three (3) years will be subject to an appropriate depreciation or user fee, including any and all freight charges being levied against the consumer.

To obtain Service Danby reserves the right to limit boundaries of "In Home Service" due to the proximity of an Authorized Service Depot. Any appliance requiring service outside the limited boundaries of "In Home Service", it will be the customer's responsibility to transport the appliance to the closest Authorized Service Depot at their own expense. Contact your dealer from whom your unit was purchased, or contact your nearest authorized Danby service depot, where service must be performed by a qualified service technician. If service is performed on the units by anyone other than an authorized service depot, or the unit is used for commercial application, all obligations of Danby under this warranty shall be at an end.

The following clause refers to single and double door refrigerators, supplied with or without a separate freezer section. Nothing within this warranty shall imply that Danby will be responsible or liable for any spoilage or damage to food or other contents of this appliance, whether due to any defect of the appliance, or its use, whether proper or improper.

EXCLUSIONS

Save as herein provided, Danby Products Limited (Canada) or Danby Products Inc. (U.S.A.), there are no other warranties, conditions, representations or guarantees, express or implied, made or intended by Danby Products Limited or its authorized distributors and all other warranties, conditions, representations or guarantees, including any warranties, conditions, representations or guarantees under any Sale of Goods Act or like legislation or statute is hereby expressly excluded. Save as herein provided, Danby Products Limited (Canada) or Danby Products Inc. (U.S.A), shall not be responsible for any damages to persons or property, including the unit itself, howsoever caused or any consequential damages arising from the malfunction of the unit and by the purchase of the unit, the purchaser does hereby agree to indemnify and save harmless Danby Products Limited from any claim for damages to persons or property caused by the unit.

GENERAL PROVISIONS

No warranty or insurance herein contained or set out shall apply when damage or repair is caused by any of the following:

- 1) Power Failure.
- 2) Damage in transit or when moving the appliance.
- 3) Improper power supply such as low voltage, defective house wiring or inadequate fuses.
- 4) Accident, alteration, abuse or misuse of the appliance such as inadequate air circulation in the room or abnormal operating conditions, (extremely high or low room temperature).
- 5) Use for commercial or industrial purposes.
- 6) Fire, water damage, theft, war, riot, hostility, acts of God such as hurricanes, floods etc.
- 7) Service calls resulting in customer education.

Proof of purchase date will be required for warranty claims; so, please retain bills of sale. In the event warranty service is required, present this document to our AUTHORIZED SERVICE DEPOT.

Warranty Service	
With-In Canada	With-In United State
In Home	In Home

Danby Products Limited
PO Box 1778, 5070 Whitelaw Road,
Guelph, Ontario, Canada N1H 6Z9
Telephone: (519) 837-0920 FAX: (519) 837-0449

Danby Products Inc.
PO Box 669, 101 Bentley Court,
Findlay, Ohio, U.S.A. 45839-0669
Telephone: (419) 425-8627 FAX: (419) 425-8629

SAFETY INSTRUCTIONS

GROUNDING INSTRUCTIONS

This wine cooler must be grounded in the event of an electrical short circuit. Grounding reduces the risk of electrical shock. This wine cooler is equipped with a power cord having a grounding wire with a grounding plug. The wine cooler plug must be plugged into a properly installed and grounded electrical outlet.

WARNING IMPROPER USE OF THE GROUNDING PLUG CAN RESULT IN THE RISK OF ELECTRIC SHOCK. Consult a qualified electrician or service person if the grounding instructions are not completely understood.

CAUTION: Read and follow all safety rules and operating instructions before using this product.

INSTALLATION INSTRUCTIONS

Remove the exterior and interior packaging. Use a soft dry cloth to thoroughly wipe the outside of the wine cooler. Use a wet, lukewarm cloth to wipe the inside of the wine cooler.

Air must circulate freely in front of the wine cooler. Avoid placing the wine cooler near any heat source, direct sunlight or moisture. Direct sunlight may affect the finish of the wine cooler. Nearby heat sources will cause higher electricity consumption.

INSTALLATION OF SHELVES

WOOD SHELVES

1. Place wood shelves on grooves at height desired.
2. Insert metal stoppers (knobs) in the holes (pre-drilled) on both sides of black liner.

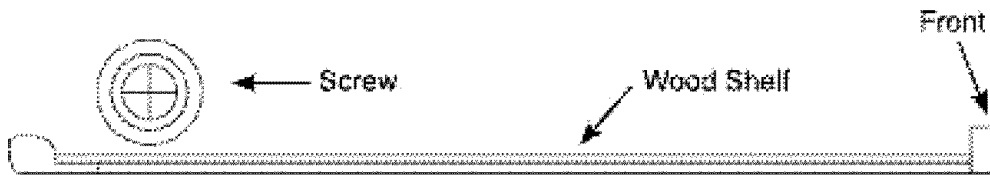

Attention

- Store wine in sealed bottles.
- Do not overload the cabinet.
- Do not open the door unless necessary
- DO NOT cover shelves with aluminum foil or any other shelf material which may prevent air circulation.
- Should the wine cooler be stored without use for long periods it is suggested, after a careful cleaning, to leave the door ajar to allow air to circulate inside the cabinet in order to avoid possible formations of condensation, mold or odors.

DOOR REVERSAL

To facilitate door reversal, we recommend someone assist you during this process.

Tools required: Phillips Screwdriver

1. Lay the unit in it's back.
2. Open the door until the screws securing the lower door support bracket are exposed on the bottom of the door.
This will require the door to be opened to a 90 degree angle.
Remove the screw closest to the bracket, as shown if Fig #1.
This will require someone to hold the door in the open position while the screw is being removed.
3. Close the door.
4. Remove the remaining screw in the lower door support.
5. Lift the door upwards and remove from the cabinet of the wine cooler.
6. Remove the 3 screws each securing the top and bottom hinge.

NOTE: Keep these hinges in a safe place in the event you ever need to revert back to a right hand door swing.

7. Remove the plastic screw caps from the left hand side of the door frame.

There are six (6) plastic caps to be removed.

8. Install the left hand top and bottom hinge (supplied with the unit) There are three (3) screws for each hinge.
9. Insert the lower door support onto the bottom hinge. Do not secure with screws until the door is installed.
10. Carefully re-position the door onto the lower door support and cabinet.
11. With door closed against the cabinet install one screw into the lower door support bracket.
12. Open the door to 90 degrees and install the second screw.
13. Close the door and check the door alignment and gasket seal.
14. Install the plastic screw caps in the right side of the cabinet.
15. Return the wine cooler to it's upright position.
16. Check the door again for proper sealing.

NOTE: Allow the unit to stand upright for 1 hour before putting the unit into operation.

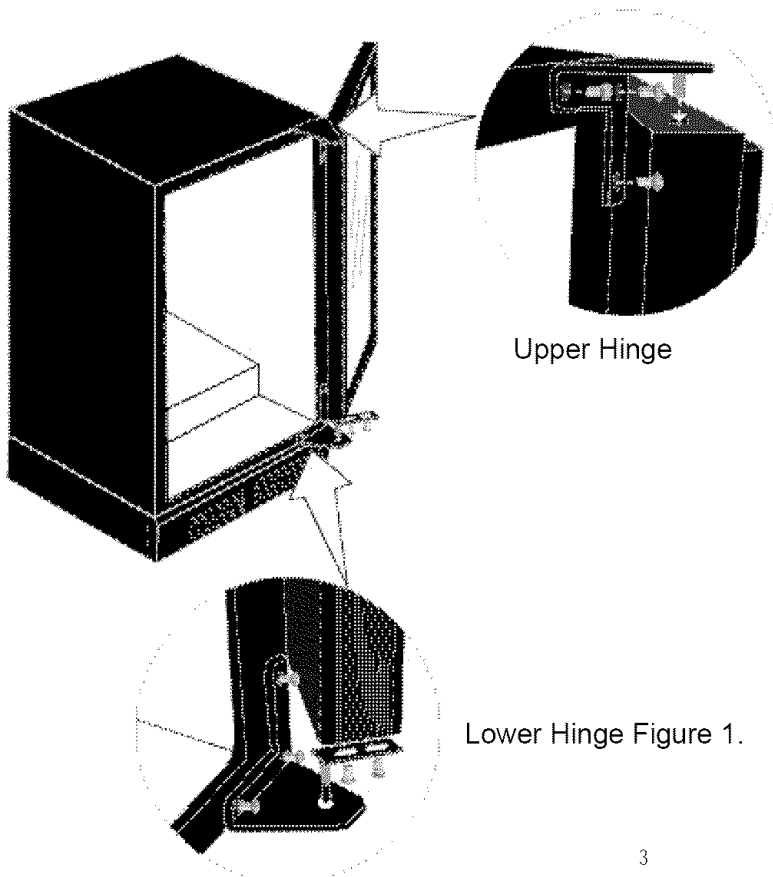

OPERATION:

Before turning on the wine cooler, ensure that the cabinet is level. This will eliminate any vibrations.

NOTE: The power (RUN) indicator light is located on the LED control panel inside the unit and will illuminate when the compressor (cooling) cycle is operational. Set the desired cooling temperature by pressing the buttons adjacent to the “up”/“down” arrows. Each depression of the buttons will increase/decrease the set temperature in increments of 1degree. The set temperature will be displayed in the LED (TEMPSET) window. It is possible to display temperatures in either Celsius or Fahrenheit. To change the setting, press and hold both buttons simultaneously for approximately 5 seconds. The green pilot light adjacent to the mode selection will illuminate the selection made.

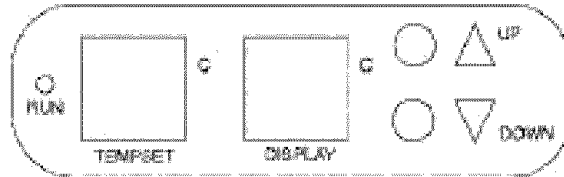

To temporarily disconnect the cooling cycle, unplug the wine cooler. When disengaging the cooling function for long periods of time, disconnect the plug and leave the door partially open.

NOTE: Wait 3 to 5 minutes before restarting the wine cooler if operation has been interrupted.

INTERIOR LIGHT

The interior light can operate “manually” or “automatically”. The light automatically comes on with the opening of the door and goes out when the door is closed. To operate the light manually, press the light/toggle switch located at the bottom right of the wine cooler exterior cabinet to the “on” position. To turn the light off, toggle the switch to the “off” position.

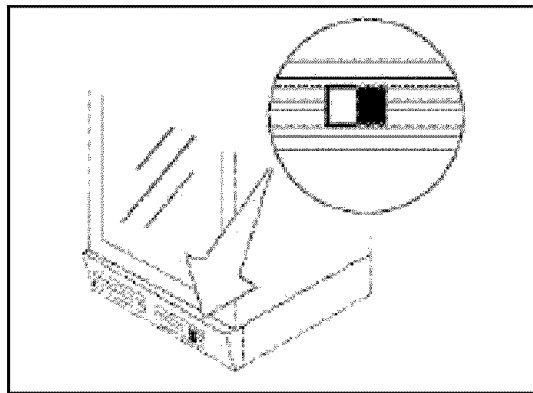

DEFROSTING/CONDENSATION

Your wine cooler is designed with an “Auto-Cycle” defrost system. During the “Off Cycle” the refrigerated surfaces of the wine cooler defrost automatically. Defrost water from the wine cooler storage compartment drains automatically, and is channeled into a condensate drain pan which is located in the back of the wine cooler next to the compressor. The heat transferred from the compressor evaporates any condensation that has collected in the pan.

CARE & MAINTENANCE

Upon receiving your wine cooler, leave the door open for 24 hours. When cleaning the inside of the wine cooler you can use a solution of a tablespoon of baking soda to one (1) quart of water, or a mild soap suds solution, or some mild detergent. Wood shelving does not require cleaning. To clean the exterior cabinet of your wine cooler, use a soft damp cloth with mild detergent or appliance cleaner.

STORING YOUR WINE COOLER

If you intend not to use the wine cooler for short periods of time, leave the control panel at its usual settings.

During longer periods of absences:

1. Remove bottles from wine cooler.
2. Unplug wine cooler from the electrical outlet.
3. Thoroughly clean the inside and outside of the wine cooler.
4. Leave the door open to avoid possible formations of condensation, mold or odors.

WHAT TO DO REGARDING POWER FAILURE

Most power failures are corrected within a short period of time. An hour or two loss of power will not affect your wine cooler temperatures. To protect your wines while the power is off, you should minimize the number of door openings. For power failures of longer durations, take steps to protect your wine.

IF YOU HAVE TO MOVE YOUR WINE COOLER

Remove ALL bottles from the wine cooler and securely fasten down all loose items inside the wine cooler. To avoid damaging the levelling legs, turn them all the way into the base of the unit.

HUMIDITY MAINTENANCE SYSTEM

The wine cooler is equipped with a system for maintaining the correct level of humidity. If humidity is too low, insert the small plastic reservoir on to the top rack of the wine cooler. Fill this reservoir 3/4 full with water. Check water level occasionally and refill as necessary.

REPLACING INTERIOR LIGHT BULBS

To replace an interior light bulb:

1. Remove the screw holding the light bulb cover. Remove the cover.
2. Unscrew light bulb. Replace the light bulb. NOTE: The light bulb should not exceed 25 watts.
3. Replace light bulb cover. Re-install screw to secure cover.

FEATURES AND BENEFITS

Powder coated, heavy duty steel cabinet with high density thermal insulation.

1. **DIGITAL ELECTRONIC THERMOSTAT:** Controls the temperature inside the wine cooler.
The compressor will cycle on as soon as the temperature rises above the desired level.
2. **WOODEN SHELVES:** Easily removable for easy access to your wine.
3. **MAGNETIC DOOR GASKET:** Tight fitting magnetic door seal keeps all the cooling power and humidity sealed inside.
4. **TEMPERED, REVERSIBLE GLASS DOOR:** Tempered glass door is tinted for UV protection allows for easy interior visibility
5. **INTERIOR LIGHT:** Allows for manual operation of interior lights to enable viewing of wines prior to opening of the door.

STORAGE OF WINE

The upper shelves are recommended for storing "Red" wine.

The lower shelves are recommended for storing "White" wine.

The humidior should be positioned in the center of the top rack.

To achieve maximum storage capacity it will be necessary to position (store) the bottles alternately on the racks. (see below diagram)

