

Installation Instructions

DDW1802W

Dishwashers

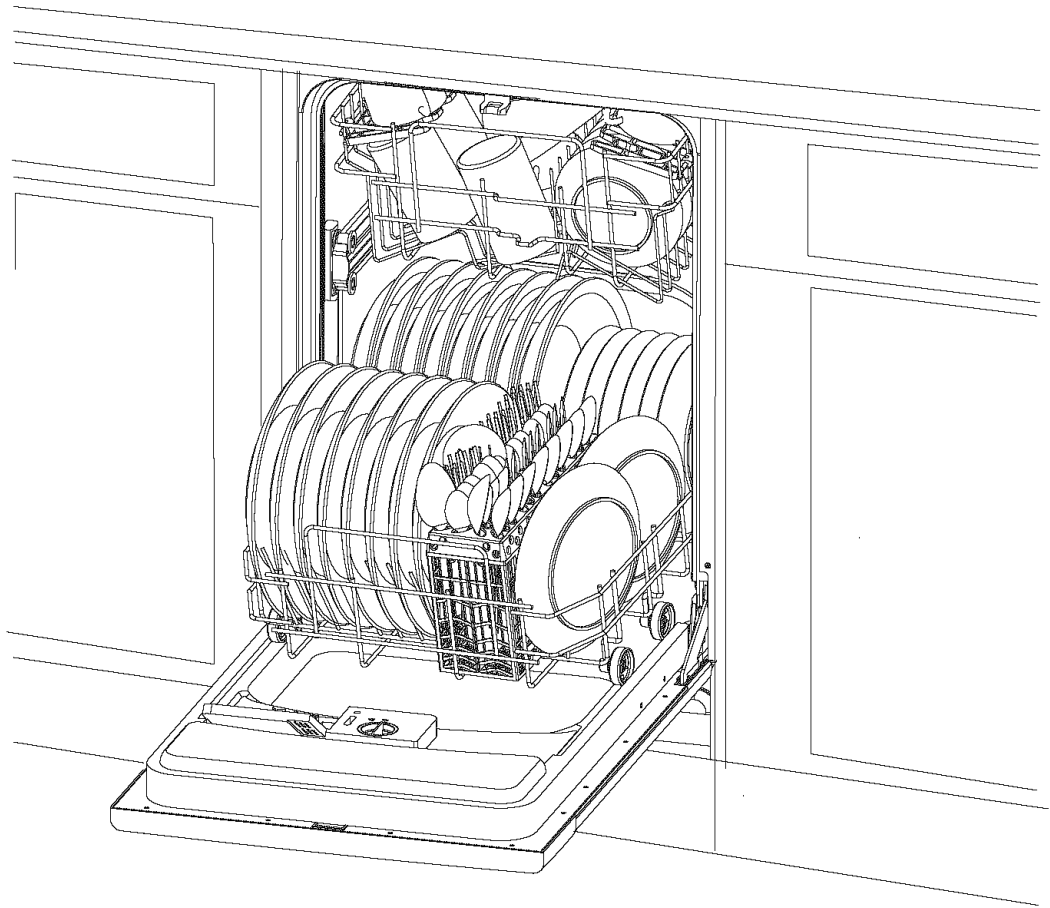

Write the model and serial numbers here:

Model # _____

Serial # _____

You can find them on the tub wall just inside the door or the lower part of back.

SAVE THESE INSTRUCTIONS



BEFORE INSTALLATION

Read these instructions completely and carefully.

⚠ WARNING ⚠	
	Electric Shock Hazard Disconnect electrical power at the fuse box or circuit breaker box before beginning installation. Failure to follow this warning could result in serious injury or death.

Note to Installer

Be sure to leave Installation Instructions and User Instructions with owner.

Note to Consumer

Keep these instructions with your Owners Manual for future reference.

Skill level

Installation of this dishwasher requires basic mechanical and electrical skills. Improper installation can result in product failure which is not covered under the Product Warranty.

IMPORTANT

The dishwasher must be installed so as to allow for future removal from the enclosure in the event service is required.

Before You Begin—Examine the dishwasher carefully, if the product is damaged, you should immediately contact one of the following:

- Danby Product Ltd. Customer Service Department
@ 1-800-26-DANBY
- Danby authorized service depot. (see authorized service depot listing enclosed with product)

⚠ WARNING ⚠	
Tip Over Hazard	
Do not use dishwasher until completely installed.	
Do not push down on open door.	
Failure to follow this warning can result in serious injury.	

CONTENTS

Material You Will Need	1
Tools	1
Unit Dimensions	2
Prepare the Location	2
Corner Installation	2
Drain Connections.....	2
Prepare Electrical Wiring.....	3
Electrical Requirement.....	3
Prepare Water Line	4
Adjust Door Balance	4
Remove Kick-Plate	4
Install Power Cord	5
Position Water Line and House Wiring.....	5
Insert Drain Hose through Cabinet and Connect Water Line	5
Slide Dishwasher into Cabinet	5
Level Dishwasher, Secure to Cabinet.....	6
Connect Drain Hose	7
Connect Power Supply	8
Pre-Test Check List	8
Dishwasher Wet Test	9
Replace Kick-Plate	9
Literature	9

Installation Preparation

MATERIALS YOU WILL NEED (INCLUDED)

- 2 #8 x 5/8" flat head wood screws to secure dishwasher to underside of countertop.
- Strain Relief for electrical connections.

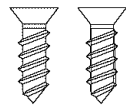

Wood Screws



Air Gap



Waste Tee

MATERIALS YOU WILL NEED (NOT INCLUDED)

- 3/8" Male (N.P.T.) 90° Elbow.
- Flexible Braid Hot Water Line (Use Engineered Polymer Braid type hose designed specifically for dishwasher installations only, available at most Hardware Stores) **DO NOT USE REGULAR (TYPE) RUBBER HOSE OR GARDEN HOSE FOR INCOMING WATER LINE.**
- Hand Shut-off Valve (5/8" O.D. tube x 3/8" O.D. tube)
- Seal (Teflon) Tape
- Electrical Cable (12 ~ 14 Gauge Wire)
- Wire Nuts (for 12 ~ 14 gauge wire)
- Air Gap Kit (depending on drain method used)
- Waste Tee (depending on drain method used)
- Drain Hose Clamps
- Drain Hose Coupler



Hand Shut-off Valve



Thread Seal Tape

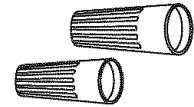

Wire Nuts

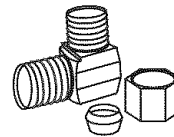

90° Elbow, Ferrule and Compression nut



Electrical Cable



Dishwasher Approved Flexible Braid Hot Water Line



Drain Hose Clamps

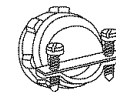

Strain Relief

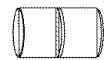

Drain Hose Coupler

TOOLS

- Head screwdriver
- 5/16" and 1/4" nutdriver
- 6" Adjustable wrench
- Level
- Carpenters square
- Measuring tape
- Safety glasses
- Flashlight
- Bucket to catch water when flushing the line
- 15/16" socket (optional for skid removal)
- Gloves
- Tubing cutter
- Drill and appropriate bits
- Hole saw set

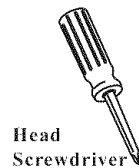

Head Screwdriver



1/4" and 5/16" Nutdriver

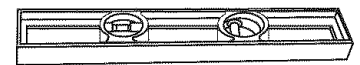

Level

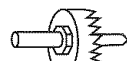

Hole Saw Set



Flashlight

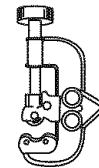

Tubing Cutter

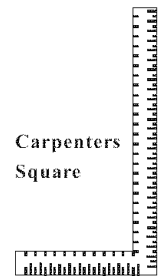

Carpenters Square



Gloves



Safety Glasses

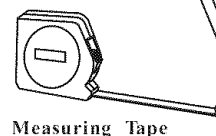

Measuring Tape

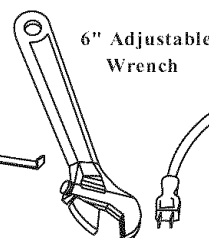

6" Adjustable Wrench

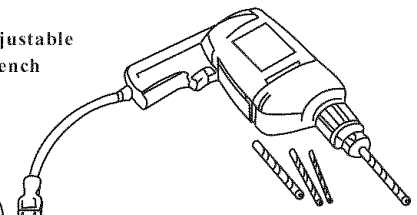

Drill and Bits

Installation Preparation

UNIT DIMENSIONS

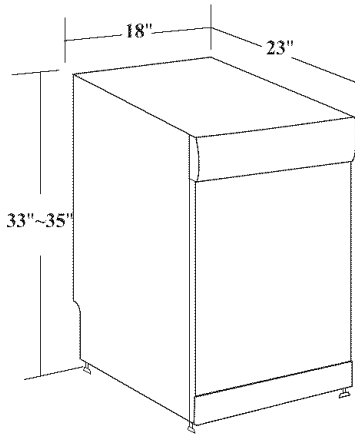

DEPTH: 23"(580mm)
 WIDTH: 18"(450mm)
 HEIGHT: 33"~35" (840~890mm)

Figure 1

PREPARE THE LOCATION

For ease of installation, the dishwasher should be installed as close as possible to the kitchen sink (plumbing) to facilitate incoming water and drain supply lines. **Note:** Built-in dishwashers must be completely enclosed on all exposed sides; (top, sides and rear)

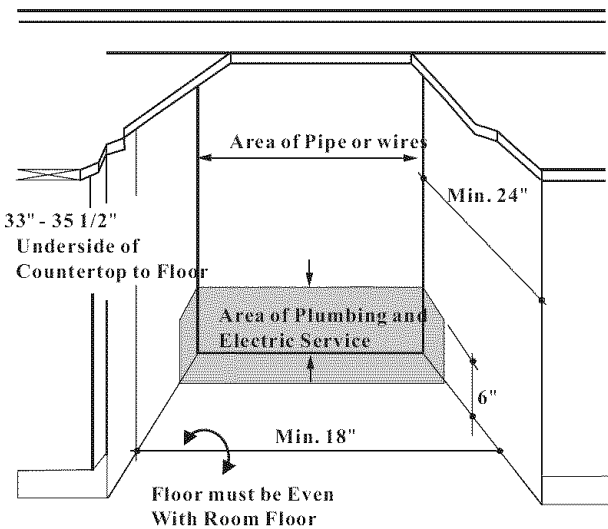
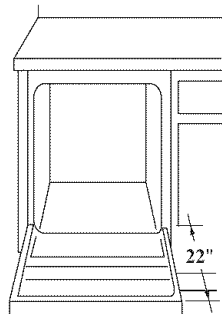

Figure 2

DEPTH: 24"(610mm)
 WIDTH: 18"(460mm)
 HEIGHT: 33"~35-1/2"(840~900mm)

CORNER INSTALLATION

If you install the dishwasher into a corner, allow 2" min. Clearance between dishwasher and adjacent cabinet, wall or other appliances. Allow 22" min. Clearance from the front of the dishwasher for door opening.



Minimum Clearance 2"

Figure 3

TYPE OF DRAIN CONNECTION:

The dishwasher comes with a factory installed drain hose. Drill 2" diameter hole to allow the drain hose to pass through the cabinet and connect to drain. (under sink)
 Review the different ways of connecting the dishwasher to the drain system. (See Figs 4, 5, 6, 7) and choose a method that best suits your (application) needs. Local codes may require that you install an air gap kit (not include) on your dishwasher, check with a qualified plumber if in doubt.

A) air gap with waste tee

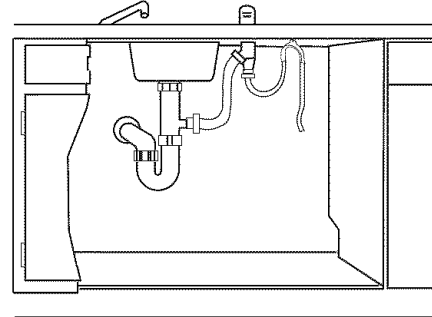

Figure 4

B) air gap with disposer

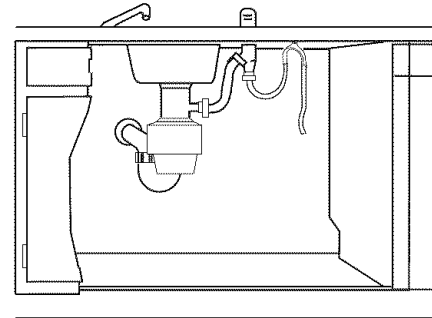

Figure 5

C) waste tee

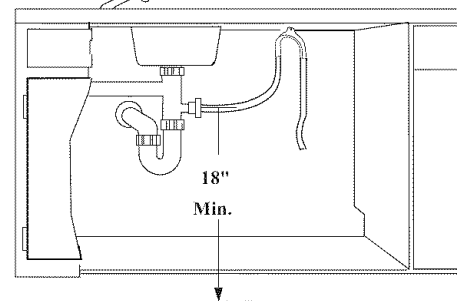

Figure 6

D) disposer

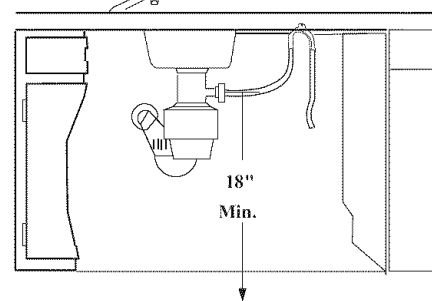

Figure 7

Installation Preparation

PREPARE ELECTRICAL WIRING

⚠ WARNING!

FOR PERSONAL SAFETY:

Disconnect electrical power at the fuse box or circuit breaker before beginning installation. Do not use extension cords or (plug) adapters with this appliance. Such can result in fire, electrical shock or other personal injury. Failure to follow these instructions could result in serious injury or death.

⚠ WARNING!

GROUNDING INSTRUCTIONS:

The dishwasher must be connected to a grounded metal, permanent wiring system. The equipment-grounding conductor must be run with the circuit conductors and connected to the appliance's equipment grounding terminal or lead. It is the customer's responsibility to contact a qualified installer (or electrician) to make sure the electrical installation conforms with the National Electrical Code and local codes and ordinances.

Do not connect the dishwasher to the power supply until the appliance is permanently grounded.

All wiring connections must be properly enclosed inside the electrical junction box.

Failure to follow these instructions could result in serious injury or death.

ELECTRICAL REQUIREMENT

This dishwasher operates on a 120 volt, 60 Hz electrical supply. You must provide a separate (individual) circuit with a fuse or circuit breaker rated for at least 15 amps, but not more than 20 amps. Your dishwasher circuit should not be used for any other appliance while the dishwasher is operational, as the dishwasher will require the full capacity of the circuit.

If the electric supply provided does not meet the above specifications, immediately contact a qualified electrician to investigate and correct any electrical supply problem(s).

The electrical connection (junction box) is located on the right front side of the dishwasher behind the kick-plate. (See Fig. 11) For cable direct (hard wire) connections, route the electrical cable as shown. (Fig. 8) The cable must extend a minimum of 24" from the rear wall to the front cabinet.

IMPORTANT: THE ELECTRICAL POWER LINE MUST NOT SHARE THE SAME OPENING (HOLE) AS THE WATER LINE.

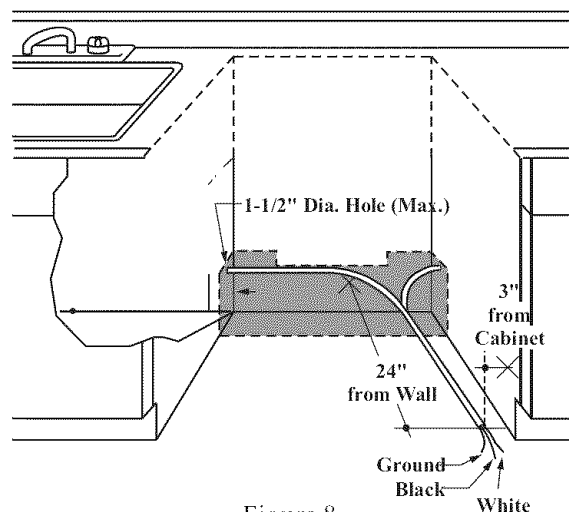

Figure 8

Installation Instructions

REMOVE KICK-PLATE

Before you can make the water/electrical connections to the dishwasher, the "kick-plate" must first be removed.

To remove the kick-plate, lay the dishwasher on it's back. Remove 4 screws (2 on each side) from the underside of the kick-plate. (See Fig.11)

It is not necessary to reinstall these screws once removed, as the kick-plate simply snaps into position when reinstalled.

To remove kick-plate, insert fingers under one side and pull upward, this may require applying some force (pressure) before the kick-plate releases. Repeat the same procedure on the opposite side.

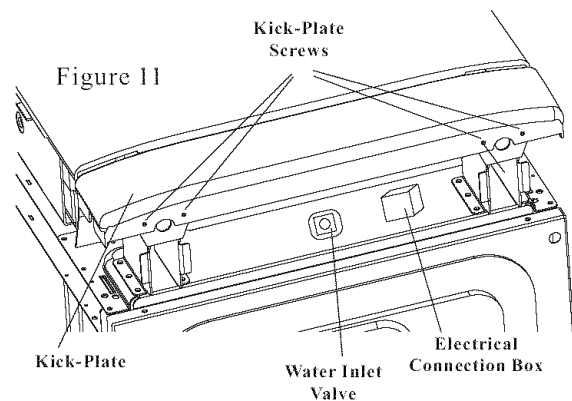

PREPARE WATER LINE

The water line should enter from the left side of the cabinet. (See Fig. 9) Drill 1-1/2" diameter hole to allow water line to pass through the cabinet. Drill a secondary 1/2" diameter hole to allow the electrical power line to pass through the cabinet.

IMPORTANT: THE WATER LINE AND ELECTRICAL LINE SHOULD NOT SHARE THE SAME HOLE/OPENING.

The dishwasher must be installed on the "hot" water line, using no less than 3/8" O.D. copper tubing, or alternatively 3/8" flexible braid (high pressure, high temperature) hose engineered/signed specifically for dishwasher installations. (this type of hose is available at most local hardware stores)

It is also recommended to install a shut-off valve in an accessible location (i.e. under the sink) between the incoming hot water supply and the dishwasher connection.

The dishwasher water "inlet valve" is located at the lower front center of the dishwasher behind the kick-plate. (See Fig. 11) Incoming water temperature should be at least 120°F (49°C) and the water pressure should be between 20~120 psi.

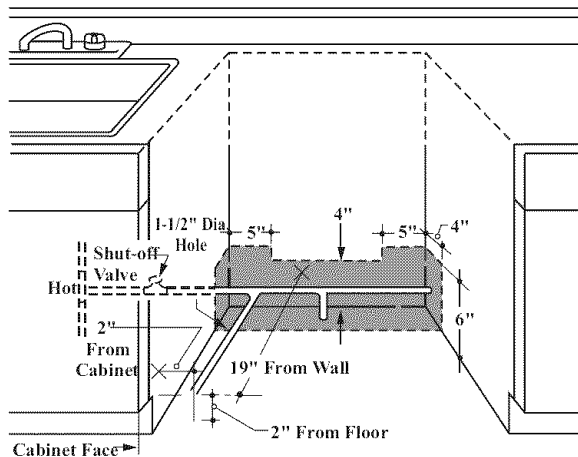

Figure 9

ADJUST DOOR BALANCE

The balance of the door is set for moderate opening/closing tension.

If you feel it is not adjusted to your satisfaction, it can be adjusted by increasing/decreasing the tension of the door springs. (See Fig. 10)

Remove the spring holding pin and reposition to higher/lower hole opening.

The higher hole openings will increase door tension.

The lower hole openings will decrease door tension.

WARNING: Always exercise extreme caution when making adjustments to the door and door springs and make sure the door is fully closed before attempting any such adjustments.

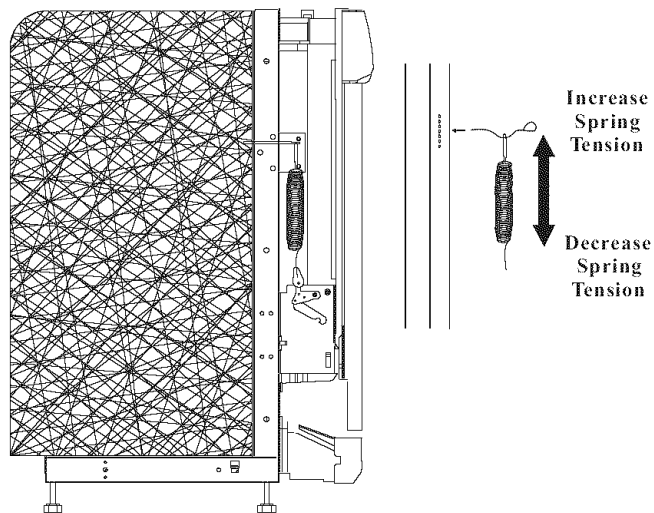

Figure 10

Installation Instructions

PREPARE DRAIN CONNECTION:

The dishwasher comes with a factory installed drain hose.

Drill 2" diameter hole to allow the drain hose to pass through the cabinet and connect to drain. (under sink)

Review the different ways of connecting the dishwasher to the drain system, (See Fig's 4, 5, 6, 7) and choose a method that best suits your (application) needs.

Local codes may require that you to install an air gap kit (not include) on your dishwasher, check with a qualified plumber if in doubt.

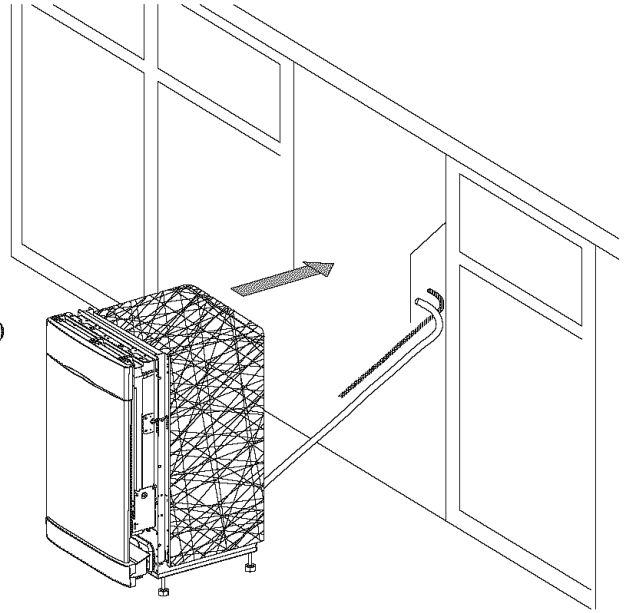

Figure 14

Installation Instructions

LEVEL DISHWASHER

IMPORTANT-- Dishwasher must be level for proper dish rack operation and wash performance.

- * Place level on door and rack track inside the tub as shown to check that the dishwasher is level.
- * Level the dishwasher by adjusting the four leveling legs.

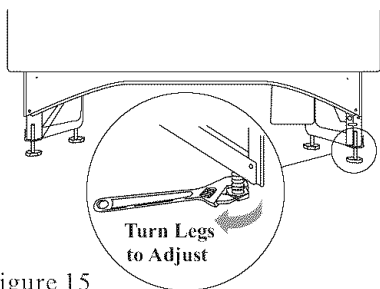

Figure 15

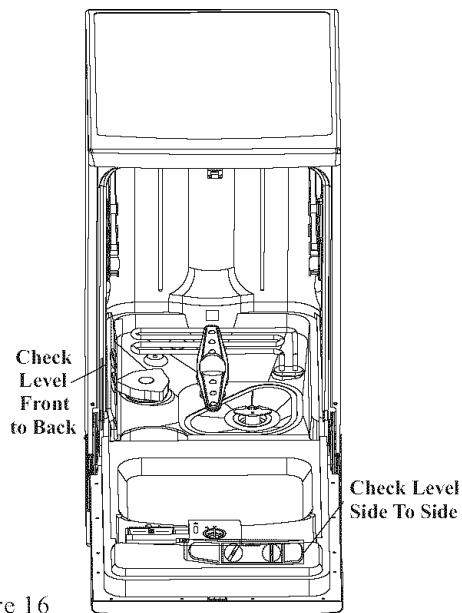

Figure 16

CONNECT WATER SUPPLY

IMPORTANT: Check and make sure the dishwasher does not rub against the incoming water supply line. The dishwasher must be installed on a "hot" water line, using no less than 3/8" O.D. copper tubing, or alternatively a Speedi-Plumb Flexible Braid (High Pressure, High Temperature) Hose Engineered/Designed specifically for dishwasher installations. (this type of hose is available at most local hardware stores) Using the flexible type hose as described above, will allow you to easily disconnect the dishwasher from the water supply line in the event the dishwasher ever has to be moved and/or serviced. Wrap (large thread) 90° elbow with pipe seal tape (or joint compound) and thread elbow into the dishwasher water inlet valve, do not over tighten. Make sure the 90° valve (connection) is facing the left side of the dishwasher. Connect one end the water line to the shut-off valve and route the other end of the water line across the (left side) kick-plate bracket and connect to the 90° elbow and tighten. (See Fig. 19)

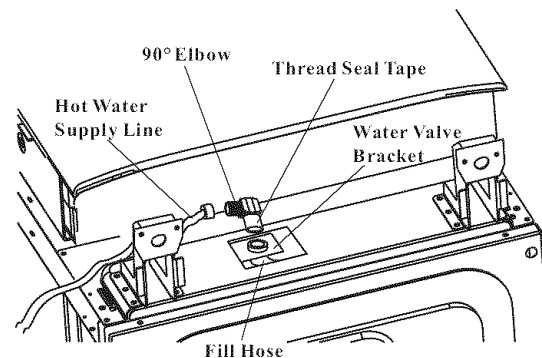

Figure 19

Installation Instructions

CONNECT DRAIN LINE

FOLLOW ALL LOCAL CODES AND ORDINANCES.

If a longer drain hose is required, add up to 42" of length for a total of 10 ft. length to the factory installed hose. Use 5/8" or 7/8" inside diameter hose and a coupler to connect the two hose ends. Secure the connection with hose clamps.

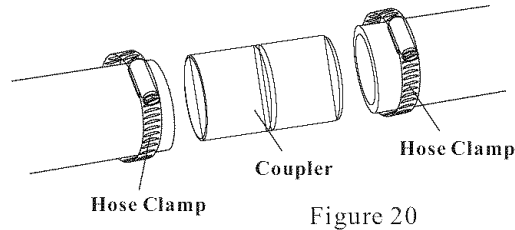

* Secure the drain hose to the air gap, waste tee or disposer with clamps.

NOTE: TOTAL DRAIN HOSE LENGTH MUST NOT EXCEED 10 FEET FOR PROPER DRAIN OPERATION.

* Connect drain line to air gap, waste tee or disposer using either previously determined method.

Method 1 --Air gap with waste tee of disposer

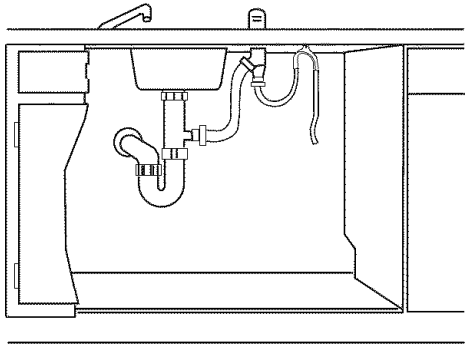

Figure 21--air gap with waste tee

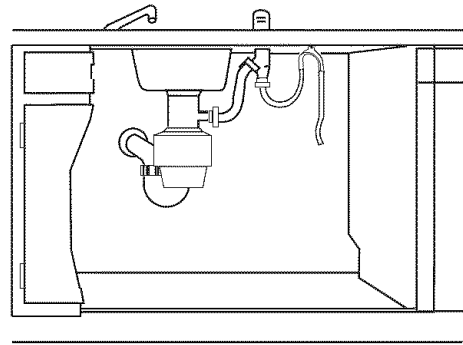

Figure 22--air gap with disposer

Method 2 --Waste tee of disposer

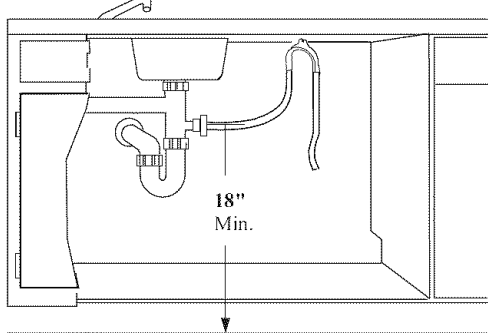

Figure 23--waste tee

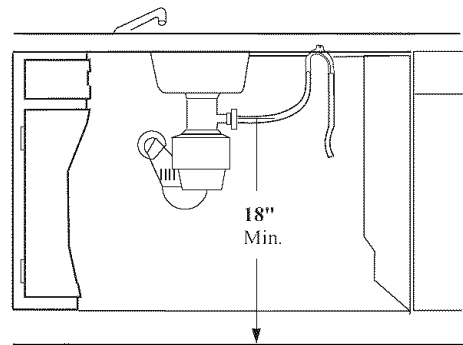

Figure 24--disposer

IMPORTANT

If drain plug of disposer or waste tee has not been removed, the dishwasher will not drain.

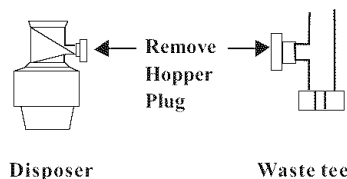

Figure 25

Installation Instructions

ELECTRICAL CONNECTIONS:

WARNING: Make sure electrical power has been disconnected at fuse box or circuit breaker box before making electrical connections.

The electrical connection (dishwasher junction box) is located on the right front side of the dishwasher behind the kick-plate. (See Fig. 11)

For cable direct (hard wire) connections, route the electrical cable as shown. (Fig. 8) The cable must extend a minimum of 24" from the rear wall to the front cabinet.

IMPORTANT: THE WATER LINE AND ELECTRICAL LINE SHOULD NOT SHARE THE SAME HOLE/OPENING.

All electrical connections must comply with the National Electrical Code and/or local codes and ordinances.

1. Remove screw securing Junction Box Cover.
2. Locate the three internal dishwasher wires;
White Wire (Neutral)
Black Wire (Hot)
Green Wire (Ground)
inside the junction box.
3. Route house wiring (power supply) to the back of junction box, secure through the strain relief, stabilize and tighten.
4. Connect incoming electrical wires and internal dishwasher wires using wire nuts as follows.
White (Neutral) to White (Neutral)
Black (Hot) to Black (Hot)
Attach Green (Ground) wires together under head of "grounding" screw inside junction box and tighten.

DO NOT USE WIRE NUTS TO MAKE GROUND CONNECTIONS.

5. Check all electrical connections are secure, replace junction box cover and screw.

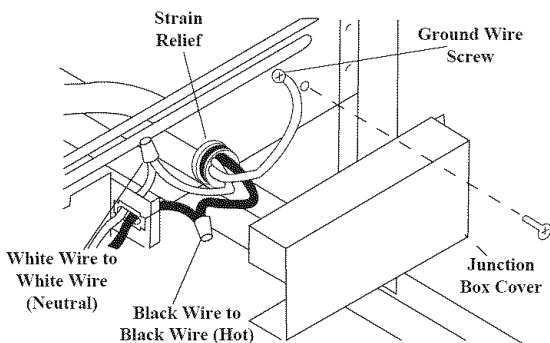

Figure 26

⚠ WARNING!

If house wiring is not 2-wire with ground, a ground must be provided by the installer. When house wiring is aluminum, be sure to use UL Listed anti-oxidant compound and aluminum-to-copper Connectors

PRE-TEST CHECK LIST

Review this list after installing your dishwasher to avoid charges for a service call that is not covered by your warranty

- Check to be sure power is OFF
- Open door and remove all foam and paper packaging.
- Locate the owner's Manual in the literature package.
- Read the owner's Manual for operating Instruction.
- Check door opening and closing. If door does not open and close freely or tends to fall, check spring cable routing.
- Check to be sure that wiring is secure under the Dishwasher, not pinched or in contact with door springs or other components.
- Check door alignment with tub. If door hits tub, level dishwasher
- Pull lower rack out, about half way. Check to be sure it does not roll back or forward on the door. If the rack moves, adjust leveling legs.
- Check door alignment with cabinet. If door hits cabinet, reposition dishwasher
- Check that door spring does not contact water line, fill hose, wiring or other components.
- Verify water supply and drain lines are not kinked or in contact with other components. Contact with motor or dishwasher frame could cause noise.
- Add 1.5 quarts of water to the bottom of the dishwasher to lubricate the pump seal.
- Turn on water supply. Check for leaks. Tighten connections if needed.

Installation Instructions

SLIDE DISHWASHER INTO CABINET:

To avoid damage, do not push against the front door panel with your knee when sliding the dishwasher into the cabinet.

Slide the dishwasher into the cabinet by (slowly) pushing the unit from side to side (See Fig. 15) As the dishwasher is pushed back, carefully pull the drain hose through the cabinet opening to prevent the hose from becoming kinked. Also make sure there is no other interference with the water/electrical lines or any other components.

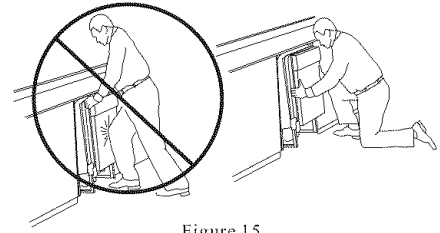

Figure 15

POSITION DISHWASHER, SECURE TO CABINET

The dishwasher must be secured to the countertop or the cabinet sides. When countertops are made of wood, use Method 1. Some models are supplied with side mounting brackets for use when countertops are granite or other materials that will not accept screws.

Method 1

Secure dishwasher to wood countertop. Position dishwasher so that the door lines up with the front face of adjacent cabinet.

IMPORTANT -- Check to be sure the dishwasher is centered in the opening and there is no interference with adjacent cabinets when opening or closing the door top with the 2 Phillips screws provided.

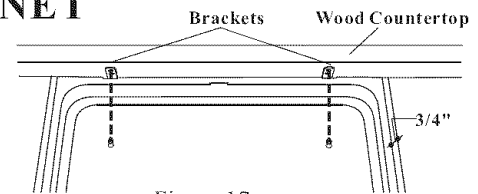

Figure 17

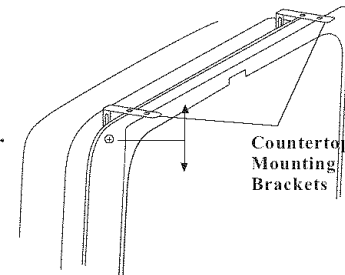
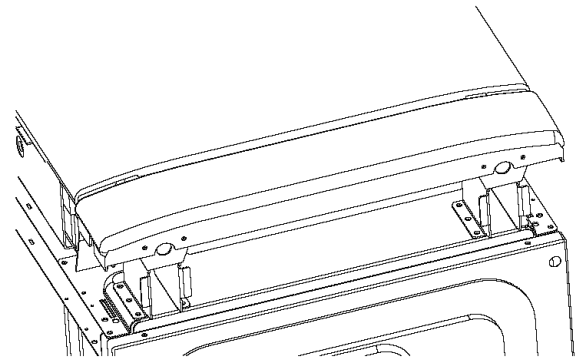

Figure 18

DISHWASHER WET TEST

- Turn on power supply
- Start with normal wash.
- Check to be sure that water enters the dishwasher
If water does not enter the dishwasher, check to be sure that water and power supply is turned on.
- Check for leaks under the dishwasher. If leak is found, turn power supply off, then tighten connections turn on power again after leak is corrected.
- Check for leaks around the door. A leak around the door could be caused by door rubbing or hitting against adjacent cabinetry reposition the dishwasher if necessary
- Check drain lines when draining. If leaks are found, turn power off, correct as necessary.
- When draining is over, open dishwasher door and make sure water has drained. If not, check that disposer plug has been removed and/or air gap is not plugged.
- Let dishwasher run through another fill and drain cycle. Check again for leaks and correct as required.

REINSTALL KICK-PLATE



Align the lock tabs on the kick-plate with the lock holes located on the front of the kick-plate brackets and push to lock into position. It is not necessary to replace the 4 mounting screws removed earlier.

LITERATURE Be sure to leave complete literature package and installation instructions with the consumer.