

Save This Manual  
For Future Reference

**SEARS**

**owner's  
manual**

**MODEL NO.  
113.234600**

**10" COMPOUND  
MITER SAW**

Serial  
Number \_\_\_\_\_  
Model and serial numbers  
may be found on the motor  
cover.  
You should record both  
model and serial number in  
a safe place for future use.

**FOR YOUR  
SAFETY:**

**READ ALL  
INSTRUCTIONS  
CAREFULLY**

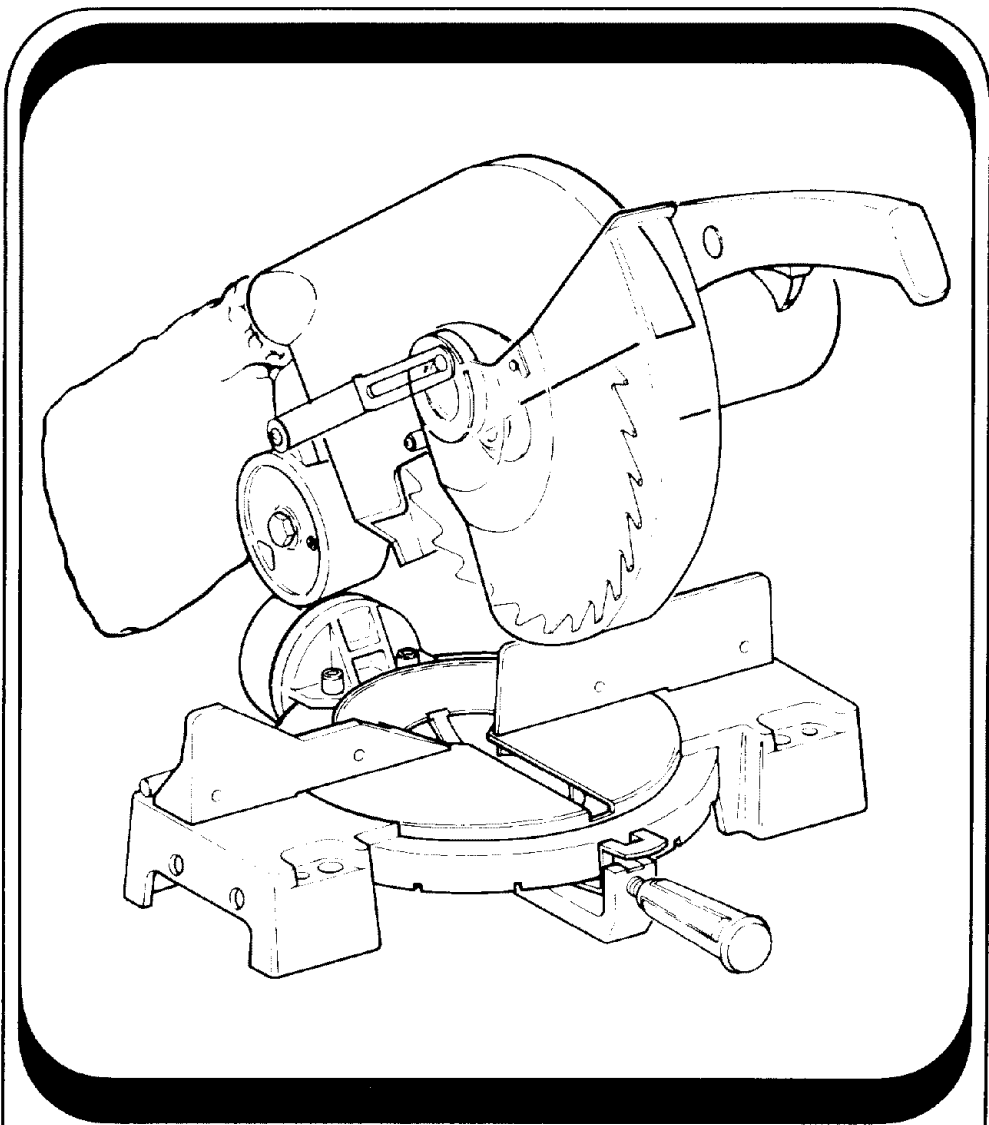

**SEARS / CRAFTSMAN®**

**10-INCH COMPOUND  
MITER SAW**

- assembly
- operating
- repair parts

Sold by SEARS, ROEBUCK AND CO., Chicago, IL 60684 U.S.A.

Part No. SP5404

Printed in Taiwan.

## FULL ONE YEAR WARRANTY ON CRAFTSMAN MITER SAW

If within one year from the date of purchase, this Craftsman Miter Saw fails due to a defect in material or workmanship, Sears will repair it, free of charge.

WARRANTY SERVICE IS AVAILABLE BY SIMPLY CONTACTING THE NEAREST SEARS SERVICE CENTER/DEPARTMENT THROUGHOUT THE UNITED STATES.

This warranty applies only while this product is used in the United States.

This warranty gives you specific legal rights, and you may also have other rights which vary from state to state.

SEARS, ROEBUCK AND CO., D/817 WA Hoffman Estates, IL 60195

## SAFETY INSTRUCTIONS FOR MITER SAW

Safety is a combination of common sense, staying alert and knowing how your miter saw works. Read this manual to understand this miter saw.

### BEFORE USING THE MITER SAW:

**WARNING:** To avoid mistakes that could cause serious, permanent injury, do not plug the miter saw in until the following steps are completed.

- Assembly and alignment. (See pages 9-13)
- Learn the use and function of the ON-OFF switch, upper and lower blade guards, handle latch, bevel clamp, cover plate stop screw, and fence clamps. (See page 8).
- Review and understand all safety instructions and operating procedures in this manual.
- Review the maintenance methods for this miter saw. (See page 23).

Read the following DANGER label found on the top of the miter saw:

<b>DANGER</b>	<b>FOR YOUR OWN SAFETY</b>	Know this tool. Read and understand the Owner's Manual before using this tool.
• Wear safety goggles complying with ANSI Z87.1	• Never reach behind or beneath the saw blade	
• Tighten arbor screw and all clamps before sawing	• Wait for blade to stop before moving workpiece, servicing or adjusting tool	
• Keep guards in place and working properly	• To avoid electrical shock, do not expose to rain	
• Keep hands out of sawblade path	• Never cut anything free hand	
• NEVER cut anything free hand		
<b>DOUBLE INSULATED</b>		Electrical: 120 volts, 60 Hz AC only, 15 amps, 5200 RPM
When servicing use only identical replacement parts.		UL

### WHEN INSTALLING OR MOVING THE MITER SAW.

Before moving the saw, lock the miter, bevel and power head positions. Unplug the power cord.

To avoid back injury, get help whenever you need to lift the miter saw more than 10 inches.

NEVER carry the saw by the cord or power head handle. Damage to insulation could cause an electric shock. Damage to wire connections could cause a fire.

AVOID DANGEROUS ENVIRONMENT. Use the miter saw in a dry, indoor place protected from rain. Keep work area well lighted.

Place the miter saw so neither the user nor bystanders are forced to stand in line with the blade. Thrown debris could injure people in its path.

### To avoid injury from unexpected saw movement:

- Put the miter saw on a firm level surface where there is plenty of room for handling and properly supporting the workpiece.
- Support the miter saw so the table is level and the saw does not rock.
- Bolt or clamp the saw to its support.
- NEVER STAND ON TOOL. Serious injury could occur if the tool tips or you accidentally hit the cutting tool. Do not store anything above or near the tool where anyone might stand on the tool to reach them.

### To avoid injury or death from electrical shock:

- THIS TOOL IS DOUBLE INSULATED to give you added protection. Double insulation does not take the place of normal safety precautions when operating this tool. When servicing this double insulated tool, use only identical parts.
- Make sure your fingers do not touch the plug's metal prongs when plugging or unplugging the miter saw.

### BEFORE EACH USE:

#### Inspect your miter saw.

DISCONNECT THE MITER SAW. To avoid injury from accidental starting, unplug the saw, before changing the setup, changing the blade or adjusting anything.

Compare the direction of rotation arrow on the guard to the direction arrow on the blade. The blade teeth should always point downward at the front of the saw.

Tighten the arbor screw.

Tighten the cover plate stop screw.

**CHECK DAMAGED PARTS. Check for:**

- Alignment of moving parts,
- Damaged electric cords.
- Binding of moving parts,
- Broken parts,
- Stable mounting,
- Function of arm return spring and lower guard: Push the arm all the way down, then let it rise up until it stops by itself. Check the lower guard to see if it closed fully. If it did not, follow the instructions in the Trouble Shooting section.
- Other conditions that may affect the way the miter saw works.

**KEEP GUARDS IN PLACE**, in working order, and in proper adjustment.

If any part is missing, bent, or broken in any way, or any electrical parts don't work, turn the saw off and unplug it. **REPLACE** damaged, missing, or failed parts before using the saw again.

**MAINTAIN TOOLS WITH CARE.** Keep the miter saw clean for best and safest performance. Follow instructions for lubricating. **DON'T** put lubricants on the blade while it's spinning.

**REMOVE ADJUSTING KEYS AND WRENCHES** from tool before turning it on.

**To avoid injury from jams, slips or thrown pieces:**

- **USE ONLY RECOMMENDED ACCESSORIES.** (See page 23). Consult this Owner's manual for recommended accessories. Follow the instructions that come with the accessories. The use of improper accessories may cause risk of injury to persons.
- Choose the right 10" inch diameter blade for the material and the type of cutting you plan to do.
- Make sure the blade is sharp, undamaged and properly aligned. With the saw unplugged, push the power-head all the way down. Hand spin the blade and check for clearance. Tilt the power-head to 45 degree bevel and repeat the check. If the blade hits anything, make the adjustments shown in the Maintaining Maximum Cutting Capacity section.
- Make sure the blade and arbor collars are clean.
- Make sure the arbor collar's recessed sides are facing the blade.
- Using a 1/2-inch box wrench, make sure the arbor cap screw is firmly hand tightened.
- Make sure all clamps and locks are tight and no parts have excessive play.
- **KEEP WORK AREA CLEAN.** Cluttered areas and benches invite accidents. Floor must not be slippery.

To avoid burns or other fire damage, never use the miter saw near flammable liquids, vapors or gases.

**Plan ahead to protect your eyes, hands, face, ears.**

**KNOW YOUR MITER SAW.** Read and understand the owner's manual and labels affixed to the tool. Learn its application and limitations as well as the specific potential hazards peculiar to this tool.

To avoid injury from accidental contact with moving parts, don't do layout, assembly, or setup work on the miter saw while any parts are moving.

**AVOID ACCIDENTAL STARTING.** Make sure switch is "OFF" before plugging miter saw into a power outlet.

**Plan your work.**

**USE THE RIGHT TOOL.** Don't force tool or attachment to do a job it was not designed to do. Use a different tool for any workpiece that can't be held in a solidly braced, fixed position.

**CAUTION: This machine is not designed for cutting ferrous metals (steel, iron and iron based metals). Use this miter saw to cut only wood, wood like products or soft metals like aluminum. Other materials may shatter, bind on the blade, or create other dangers.**

**CAUTION: When cutting any metals, sparks or hot fragments could cause a fire. To avoid this, disconnect any dust collecting hose from the miter saw, and remove all traces of wood dust from inside dust traps in the miter saw.**

**Dress for safety.**



Any power miter saw can throw foreign objects into the eyes. This can cause permanent eye damage. Wear safety goggles (not glasses) that comply with ANSI Z87.1 (shown on package). Everyday eyeglasses have only impact resistant lenses. They are not safety glasses. Safety goggles are available at Sears retail catalog stores. Glasses or goggles not in compliance with ANSI Z87.1 could seriously hurt you when they break.

- Do not wear loose clothing, gloves, neckties or jewelry (rings, wrist watches) They can get caught and draw you into moving parts.
- Wear nonslip footwear.
- Tie back long hair.

- Roll long sleeves above the elbow.
- Noise levels vary widely. To avoid possible hearing damage, wear ear plugs or muffs when using miter saw for hours at a time.
- For dusty operations, wear a dust mask along with the safety goggles.

**Inspect your workpiece.**

- Make sure there are no nails or foreign objects in the part of the workpiece to be cut.

**Plan your work to avoid THROWBACKS—when the workpiece binds on the blade and is torn from your hands.**

Plan the way you will hold the workpiece from start to finish:

Avoid awkward operations and hand positions where a sudden slip could cause fingers or hand to move into the blade.

**DON'T OVERREACH.** Keep good footing and balance.

Keep your face and body to one side, out of line with a possible throwback.

**Never cut FREEHAND:**

- Brace your workpiece solidly against the fence and table top so it will not rock or twist during the cut.
- Make sure there's no debris between the workpiece and its supports.
- Make sure no gaps between the workpiece, fence and table will let the workpiece shift after it is cut in two.
- Keep the cut off piece free to move sideways after it's cut off. Otherwise, it could get wedged against the blade and thrown violently.
- Clear everything except the workpiece and related support devices off the table before turning the miter saw on.
- **SECURE WORK.** Use clamps or a vise to help hold the work when it's practical.

**Use extra caution with large, very small or awkward workpieces:**

- Use extra supports (tables, saw horses, blocks, etc.) for any workpieces large enough to tip when not held down to the table top.
- **NEVER** use another person as a substitute for a table extension, or as additional support for a workpiece that is longer or wider than the basic miter saw table, or to help feed, support or pull the workpiece.
- Do not use this saw to cut pieces too small to let you easily hold the work while you keep the thumb side of your index (pointer) finger against the outside edge of the fence.
- When cutting irregularly shaped workpieces, plan your work support so it will not slip, pinch the blade and be torn from your hands. A piece of molding, for example, must lie flat or be held by a fixture or jig that will not let it twist, rock or slip while being cut.
- Properly support round material such as dowel rods, or tubing. They have a tendency to roll while being cut, causing the blade to "bite". To avoid this, always use a fixture designed to properly hold your workpiece.

**WARNING: If planning to cut aluminum or other non-ferrous metals: Under adverse conditions, the blade can grab and throw the workpiece suddenly and unexpectedly. To avoid injury, follow all applicable safety instructions, as you normally would, and:**

- Use only sawblades specifically recommended for non-ferrous metal cutting.
- Do not cut metal workpieces that must be hand held. Use auxiliary clamps or other equipment as needed.
- Cut non-ferrous metals only if you are experienced or under the supervision of an experienced person.

**WHENEVER SAW IS RUNNING.**

**WARNING: Don't let familiarity (gained from frequent use of your miter saw) cause a careless mistake. A careless fraction of a second is enough to cause a severe injury.**

Before starting your cut, watch the miter saw while it runs. If it makes an unfamiliar noise or vibrates a lot, stop immediately. Turn the miter saw off. Unplug the miter saw. Do not restart until finding and correcting the problem.

**KEEP CHILDREN AWAY.** Keep all visitors a safe distance from the miter saw. Make sure bystanders are clear of the miter saw and workpiece.

Never confine the piece being cut off. Never hold it, clamp it, touch it, or use length stops against it while the blade is spinning. It must be free to move sideways on its own. If confined, it could get wedged against the blade and thrown violently.

Let the blade reach full speed before cutting.

**DON'T FORCE TOOL.** It will do the job better and safer at its designed rate. Feed the blade into the workpiece only fast enough to let it cut without bogging down or binding.

**Before freeing any jammed material:**

- Turn switch "OFF".
- Unplug the miter saw.
- Wait for all moving parts to stop.

**After finishing a cut:**

- Keep holding the power head down.
- Release the switch, and wait for all moving parts to stop before moving your hands.
- If blade doesn't stop within 6 seconds, unplug the saw and follow the instructions in the Trouble Shooting section for fixing the blade brake before using the saw again.

**BEFORE LEAVING THE SAW:**

**NEVER LEAVE TOOL RUNNING UNATTENDED.** Turn power off. Wait for all moving parts to stop.

Make workshop child-proof. Lock the shop. Disconnect master switches. Remove the yellow switch key. Store it away from children and others not qualified to use the tool.

# glossary of terms for woodworking

## Arbor

The shaft on which a cutting tool is mounted.

## Bevel Cut

An angle cutting operation made through the face of the work piece.

## Compound Cut

A simultaneous bevel and miter cutting operation.

## Crosscut

A cutting operation made across the width of the work-piece.

## Freehand

Performing a cut without the use of fence (guide), hold down or other proper device to prevent the workpiece from twisting during the cutting operation. Twisting of the workpiece can cause it to be thrown.

## Gum

A sticky, sap based residue from wood products.

## Heel

Misalignment of the blade.

## Kerf

The amount of material removed by the blade in a through cut or the slot produced by the blade in a non-through or partial cut.

## Miter Cut

An angle cutting operation made across the width of the work piece.

## Resin

A sticky, sap based substance that has hardened.

## Revolutions Per Minute (RPM)

The number of turns completed by a spinning object in one minute.

## Sawblade Path

The area of the workpiece or table top directly in line with either the travel of the blade or the part of the workpiece which will be, or has been, cut by the blade.

## Set

The distance that the tip of the sawblade tooth is bent (or set) outward from the face of the blade.

## Workpiece

The item on which the cutting operation is being performed. The surfaces of a workpiece are commonly referred to as faces, ends, and edges.

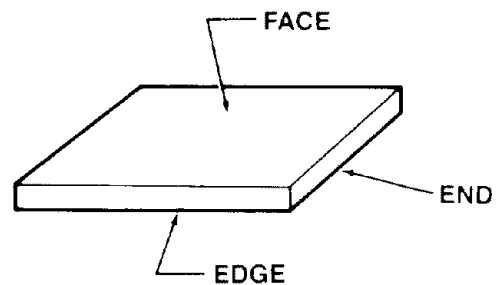

## electrical connections

### POWER SUPPLY

#### Motor Specifications

The AC motor used in this saw is a universal, nonreversible type having the following specifications:

H.P. ....	3
Voltage ....	120
Amperes ....	15
Hertz (Cycles) ....	60
Phase ....	Single
RPM ....	5200
Rotation of Shaft ....	Clockwise
Brake ....	Automatic

**WARNING:** To avoid electrical hazards, fire hazards, or damage to the tool, use proper circuit protection. Your saw is wired at the factory for 120V operation. Connect to a 120V, 15-AMP, branch circuit and use a 15-AMP time delay fuse or circuit breaker. To avoid shock or fire, if power cord is worn or cut, or damaged in any way, have it replaced immediately.

### DOUBLE INSULATED

The miter saw is double insulated to provide a double thickness of insulation between you and the tool's electrical system. All exposed metal parts are isolated from the internal metal motor components with protecting insulation.

Your unit has a plug that looks like the one shown below.

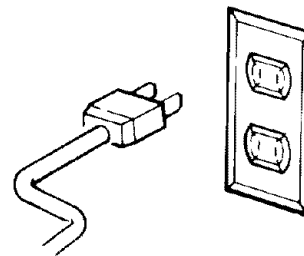

This power tool is equipped with a 2-conductor cord listed by Underwriters Laboratories (UL). The plug permits you to use any conventional 120-volt electrical outlet without necessity for maintaining a ground connection.

**CAUTION:** Double insulation does not take the place of normal safety precautions when operating this tool.

#### DANGER: To avoid electrocution:

1. Use only identical replacement parts when servicing a tool with double insulation. Servicing should be performed by a qualified service technician.
  2. Do not use in rain or where floor is wet.
- This tool is intended for indoor residential use only.

## MOTOR SAFETY PROTECTION

**CAUTION: To avoid motor damage, this motor should be blown out or vacuumed frequently to keep sawdust from interfering with normal motor ventilation.**

1. Connect this tool to a 120V, 15-amp branch circuit with a 15-amp time delay fuse or circuit breaker. Using the wrong size fuse can damage the motor.
2. If the motor won't start, release the trigger switch immediately. UNPLUG THE TOOL. Check the saw blade to make sure it turns freely. If the blade is free, try to start the motor again. If the motor still does not start, refer to the "Motor Trouble-Shooting Chart."
3. If the motor suddenly stalls while cutting wood, release the trigger switch, unplug the tool, and free the blade from the wood. The motor may now be restarted and the cut finished.
4. Fuses may "blow" or circuit breakers may trip frequently if:
  - a. MOTOR IS OVERLOADED—Overloading can occur if you feed too rapidly or make too many start/stops in a short time.
  - b. Voltages not more than 10% above or below the nameplate voltage can handle normal loads. For heavy loads, however, the voltage at motor terminals must equal the voltage specified on nameplate.

5. Most motor troubles may be traced to loose or incorrect connections, overload, low voltage (such as small size wire in the supply circuit) or to overly long supply circuit wire. Always check the connections, the load and the supply circuit whenever motor doesn't work well. Check wire sizes and length with the Wire Size Chart below.

For circuits that are farther than 100 feet away from electrical service box, the wire size must be increased proportionately in order to deliver ample voltage to the saw motor.

## WIRE SIZES

The use of any extension cord will cause some loss of power. To keep this to a minimum and to prevent overheating and motor burn-out, use the table below to determine the minimum wire size (A.W.G.) extension cord.

Length of the Conductor	Wire Sizes Required For 120V (American Wire Gage Number)
0–25 Ft.	16
26–50 Ft.	14
51–100 Ft.	12

## contents

	Page	Page	
Guarantee . . . . .	2	Assembly and Alignment . . . . .	9
Safety Instructions for Miter Saw . . . . .	2	Mounting the Saw . . . . .	13
Glossary of Terms for Woodworking . . . . .	5	Basic Saw Operations . . . . .	18
Electrical Connections . . . . .	5	Maintenance and Lubrication . . . . .	23
Unpacking and Preassembly . . . . .	7	Trouble Shooting . . . . .	24
Knowing Your Miter Saw . . . . .	8	Repair Parts . . . . .	26

## UNPACKING AND PREASSEMBLY

**WARNING:** To avoid injury from unexpected starting or electrical shock, do not plug the power cord into a source of power during unpacking and assembly. This cord must remain unplugged whenever you are working on the saw.

Model 113.234600 is shipped complete in one box.

**WARNING:** Although small, this saw is heavy. To avoid back injury, get help whenever you have to lift the saw more than 10 inches.

1. Remove the miter saw from the carton by lifting the saw by the base.

**WARNING:** If any part is missing or damaged, do not plug the saw in until the missing or damaged part is correctly replaced. To avoid electric shock, use only identical replacement parts when servicing double insulated tools.

2. Place the saw on a secure stationary work surface and look the saw over carefully.

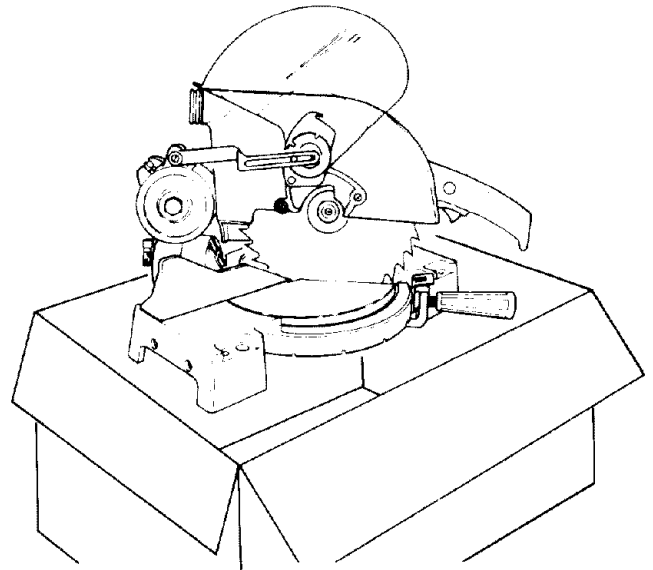

## tools needed

Tools required for assembly and alignment of Miter Saw:

- Medium Screwdriver
- #2 Phillips Screwdriver
- Combination Square
- 1/2" Box End/Open End Wrench or Socket
- 2 - 15/16" Box End/Open End Wrenches or Adjustable Wrenches or Socket Wrenches
- 5/16" Hex "L" Wrench

### COMBINATION SQUARE MUST BE TRUE

DRAW LIGHT LINE ON BOARD ALONG THIS EDGE

STRAIGHT EDGE OF BOARD 3/4" THICK THIS EDGE MUST BE PERFECTLY STRAIGHT

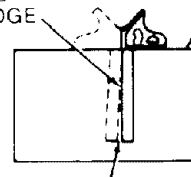

SHOULD BE NO GAP OR OVERLAP WHEN SQUARE IS FLIPPED OVER IN DOTTED POSITION

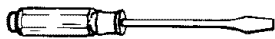

MEDIUM SCREWDRIVER

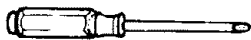

#2 PHILLIPS SCREWDRIVER



COMBINATION SQUARE



5/16" HEX "L" WRENCH

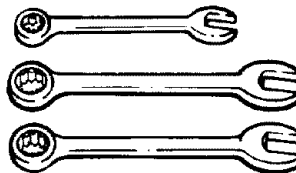

1/2" WRENCH

15/16" BOX END/OPEN END WRENCHES



ADJUSTABLE WRENCH



1/2" SOCKET



15/16" SOCKETS & SOCKET WRENCHES

# knowing your miter saw

1. Warning label.
2. Handle Latch—The miter saw can be locked in the lowered position for compact storage.
3. Fence Lock Handles—The fence has two positions for increased crosscut capacity. The lock handles secure the fence to the base. The saw is shipped with the fence in the front position.

**NOTE:** If the fence is being used in the rear position, the two fence lock handles must be loosened before changing the miter angle. Then tighten the fence handle at the desired miter angle before starting a cut.

4. Miter Lock Handle—The miter lock handle securely locks the miter saw at a desired miter angle. Index points have been provided at 0, 22.5 R/L, and 45 R/L.
5. Bevel Lock Handle—The bevel lock handle locks the miter saw at a desired bevel angle.
6. Lower Blade Guard—The blade guard helps protect your hands from the blade in the raised position. To avoid binding on the workpiece, it retracts as the blade is lowered.
7. Miter Saw Handle—The saw handle contains the trigger switch with a lock-off button. The blade is lowered into the workpiece by pushing down on the handle. The saw will return to its upright position when the handle is released.

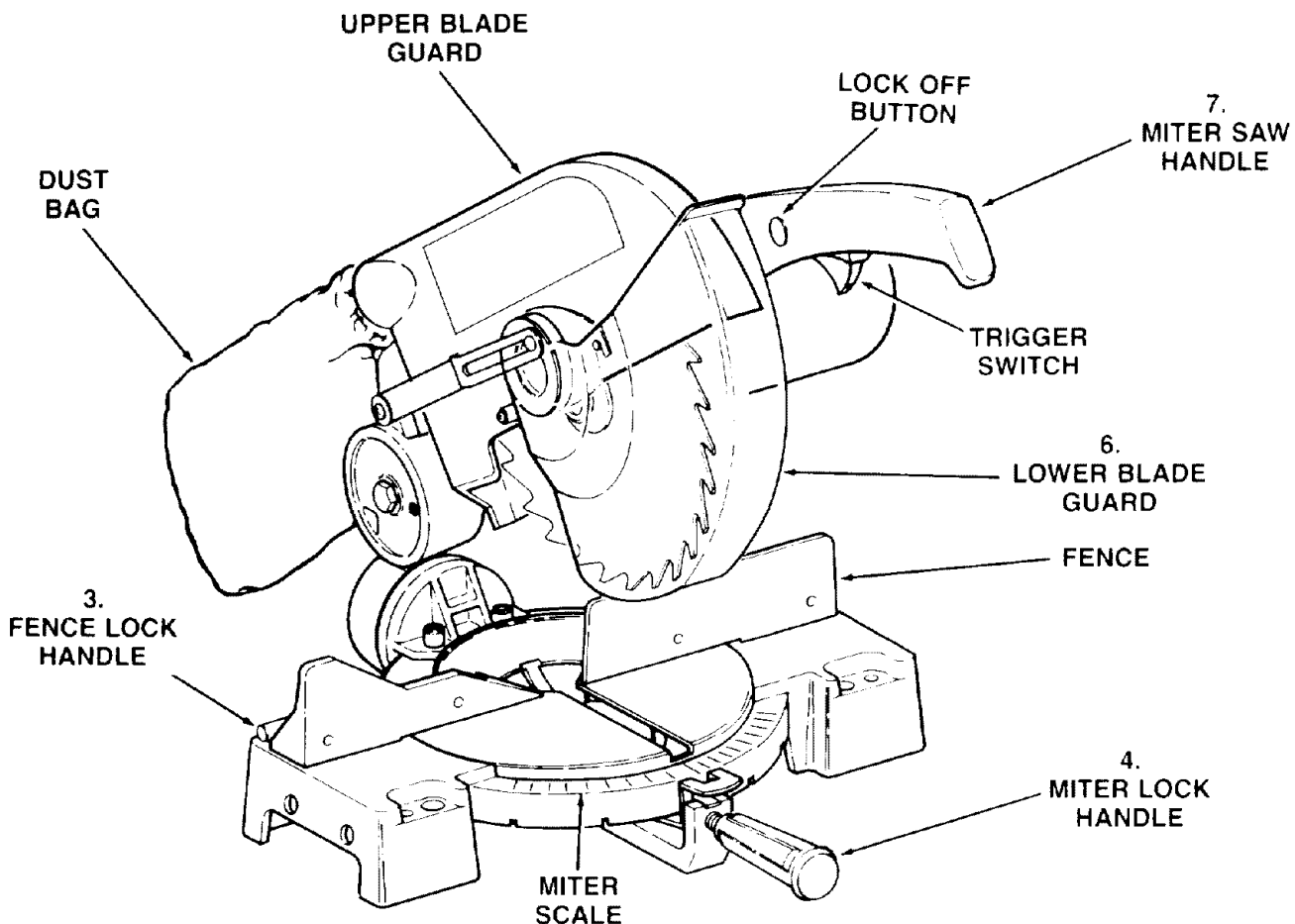
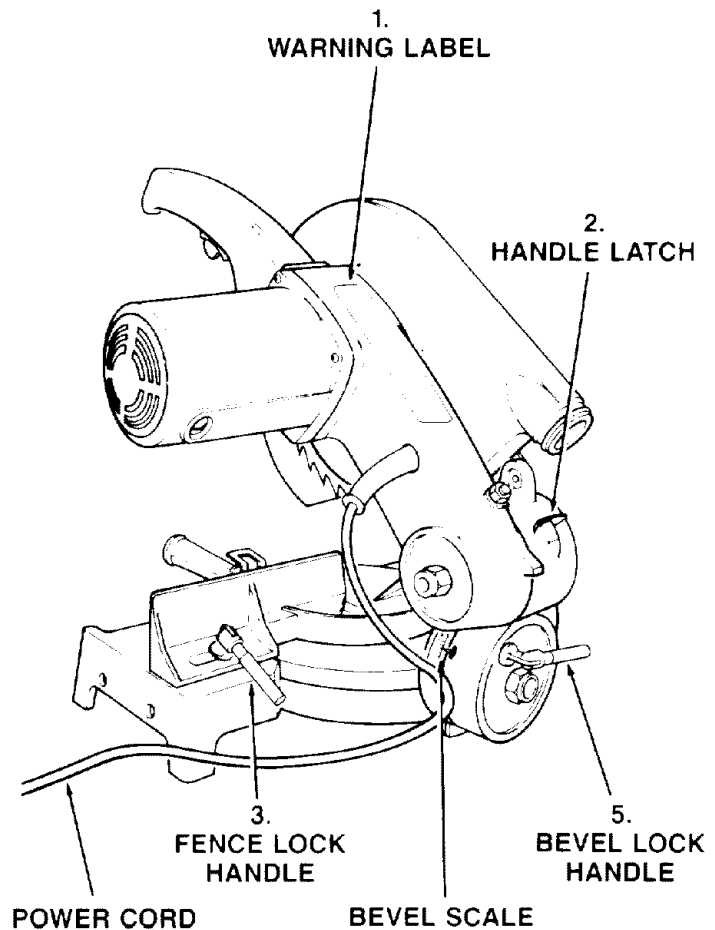



# assembly and alignment

## ASSEMBLY AND ALIGNMENT

### Assembling the Lower Blade Guard

**NOTE:** For compact shipment the lower blade guard has been partially disconnected.

1. The miter saw is equipped with a handle latch used to lock the miter saw in the lowered position. To release, push the handle down slightly and turn the handle latch to the other side.
2. Release the handle latch and raise the saw to its up position.
3. Slide the lower guard assembly down until the groove in the mounting plate rests on the front screw. Tighten the screw with a phillips screwdriver.
4. Remove the 1/4-20 shoulder screw from the pivot casting as illustrated. Attach the blade guard link to the pivot casting with a phillips screwdriver.

**NOTE:** With the blade guard link attached, the guard should raise as the blade is lowered towards the work table and drop to cover the blade as the power head is raised. This link helps prevent guard hangups and binding while you are cutting.

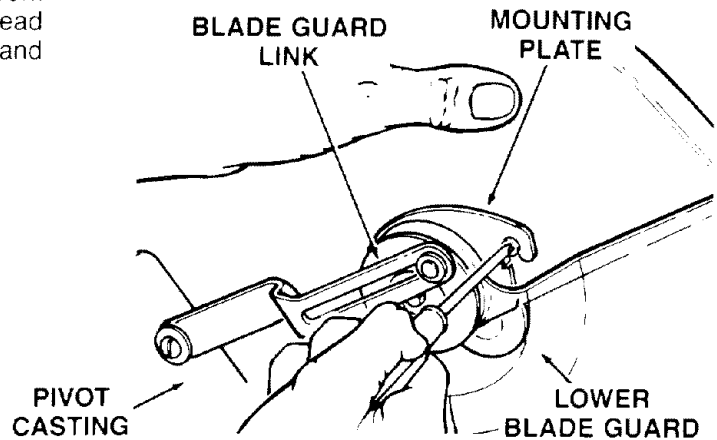
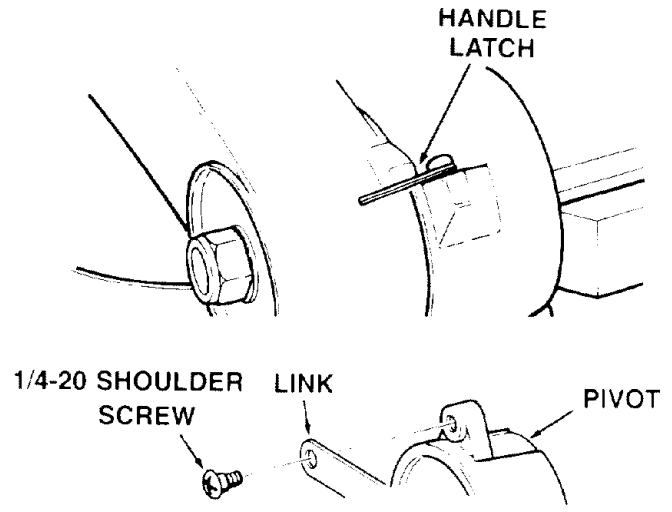

## Assembly and Alignment

### Step One—Blade Square to Table

**NOTE:** The miter saw was assembled, aligned, and inspected before shipment. Alignment should be checked and any adjustments made to insure accurate cuts.

1. Check miter lock handle setting. The miter lock handle should be at the 0° position. To reset the miter angle, turn the miter lock handle counter clockwise and press down the index spring.
2. Lower the blade and lock the handle latch. Use the combination square to check blade squareness to table. If the blade does not contact the full length of the square, follow the alignment procedure.
  - a. Loosen bevel lock handle.
  - b. Grasping metal upper guard, move the cutting head left or right until blade makes contact with the full length of the square.
  - c. Tighten the bevel lock handle.
3. Check the bevel indicator. If indicator needs adjustment use a phillips screwdriver and slide the indicator to the 0° on the scale.

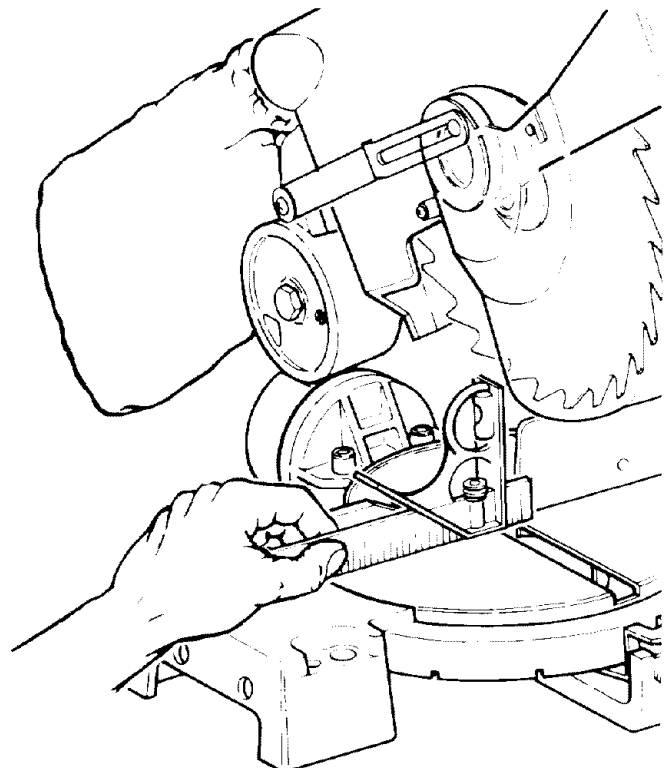

## Step Two—Checking and Aligning Blade with Turn Table Slot

1. The blade should look like it's parallel to the sides of the turn table slot. The blade should be  $\frac{1}{8}$ " closer to left side than right.
2. If blade looks parallel with turn table slot proceed to step three. If necessary, realign blade with turn table slot, adjust as follows.
  - a. Use a  $\frac{5}{16}$ " hex "L" wrench to loosen (but do not remove) the two cap screws that attach pivot support to turn table. Move blade power-head so it is parallel with turn table slot. Securely tighten cap screws. Recheck blade position and readjust if necessary. Always check blade clearance to table when the miter saw is fully tilted to the left.

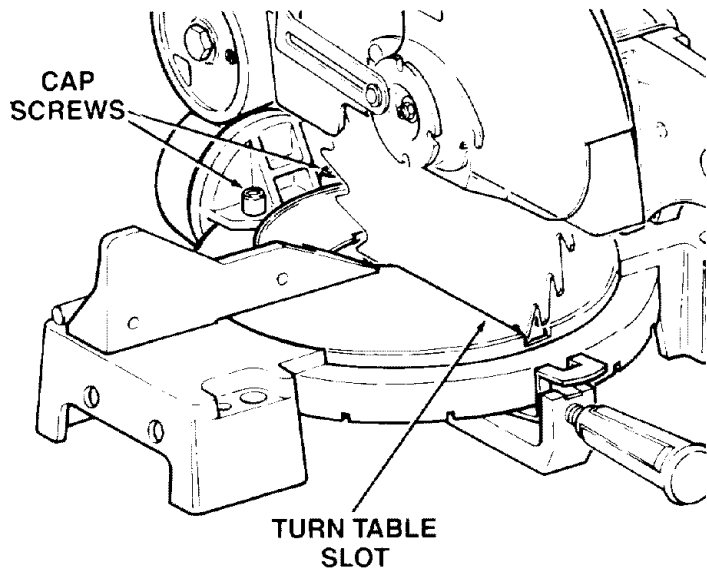

## Step Three—Checking and Adjusting Blade Squareness to Fence (Front Fence Position)

1. To check blade squareness to fence, use a combination square. Place the square against the fence and next to the blade as illustrated. Place the square so the set in the teeth won't hold it from the blade. The blade should contact the full length of the square.
2. If blade contacts full length of square, proceed to next step. If blade is not square to the fence, follow the alignment procedure.
  - a. Loosen miter lock handle a half turn. The latch handle should still be secured with blade in lowered position.

**NOTE:** Take the saw off its stand, bench or plywood base if readjustment is necessary.

**CAUTION:** To keep from losing control of the unit, steady the base with one hand while loosening the two bolts with the other hand.

- b. With the unit securely resting on a large stable surface, tilt the unit by lifting up on one side or the other of the base. Loosen the two miter arm bolts on the underside of the turn table with a  $\frac{1}{2}$ " wrench or socket. Tilt the unit by lifting up on one side or the other of the base.
- c. Return the saw to its normal resting position. Make sure the miter lock handle is loose but do not release the index spring.
- d. Use the miter saw handle to turn the turn table and saw so that the blade contacts the full length of the square. Watch out for tooth set. Turn the miter lock handle clockwise to lock saw square to fence.
- e. Tilt saw as in Step B and tighten bolts.
- f. Recheck blade squareness to fence and readjust if necessary.

## Adjustment of Miter Scale Indicator

1. Loosen the phillips screws that hold the indicator in place. Reposition the indicator and retighten screw.

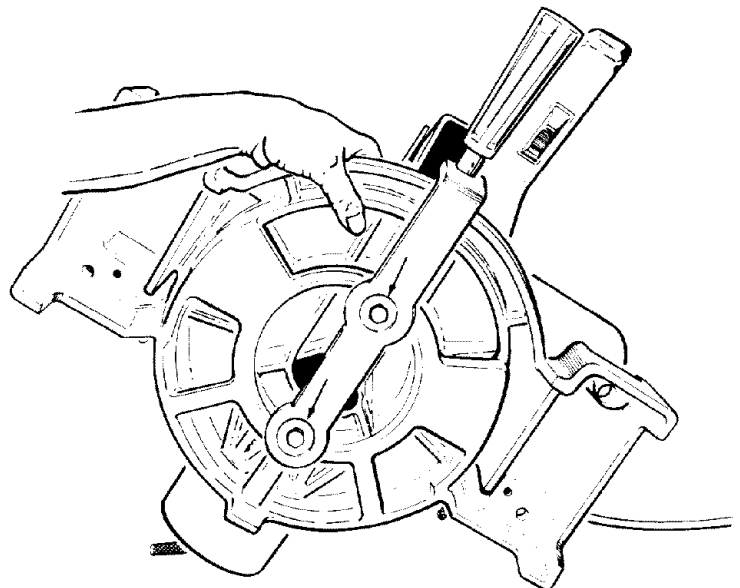
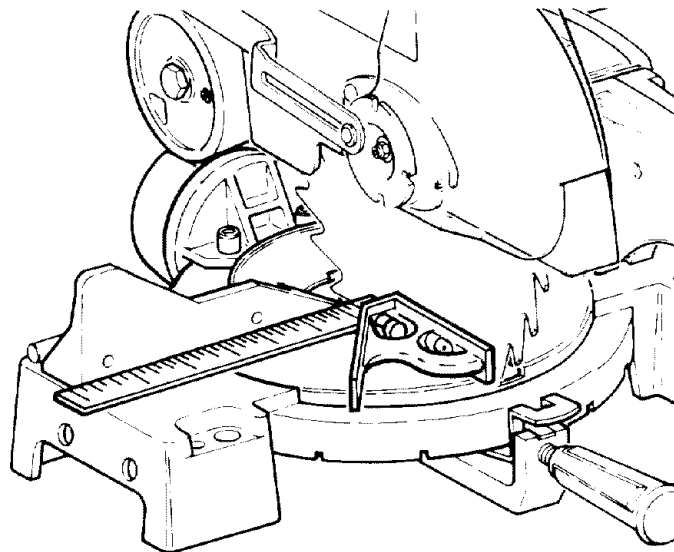

### Step Four—Pivot Adjustments

**NOTE:** These adjustments were made at the factory and normally do not require readjustment.

1. The miter saw should rise completely to the up position by itself. If the saw will not raise by itself or if there is play in the pivot joints the following adjustments are necessary.

#### Travel Pivot Adjustments

- a. Hold the pivot bolt with an adjustable or  $1\frac{5}{16}$ " wrench. Loosen the hex lock nut with an adjustable or  $1\frac{5}{16}$ " wrench.
- b. Recheck the saw travel. Saw should rise freely to its up travel stop. Check to see that the saw will raise from all positions and there is no looseness in the pivot. If saw still won't fully rise, have Sears Service check and repair it.

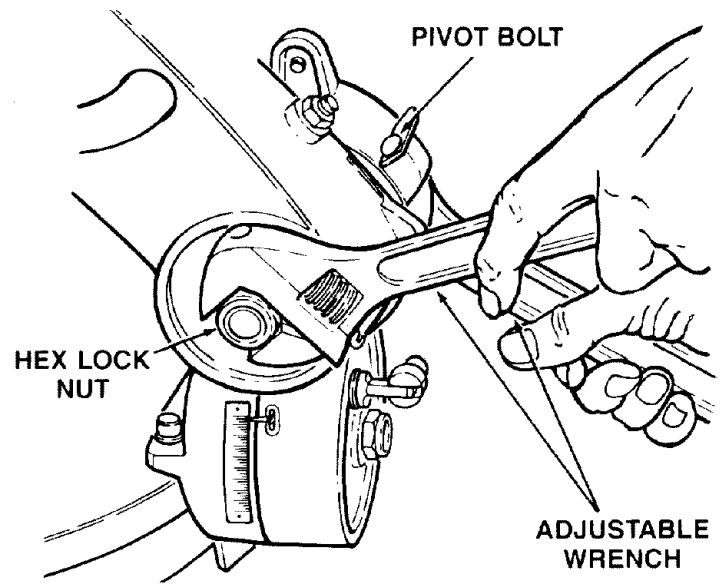

#### Bevel Pivot Adjustment

1. The miter saw should bevel easily by loosening the bevel lock handle and tilting the power head to the left. If movement is tight or if there is looseness in the pivot follow the adjustment procedure.
  - a. Loosen the bevel lock handle.
  - b. Turn the hex lock nut with an adjustable or  $1\frac{5}{16}$ " wrench.
  - c. Recheck bevel movement of the miter saw. Re-adjust if necessary.

#### Depth Stop

The depth stop limits the blades downward travel. It allows the blade to go below the work table enough to maintain full cutting capacities. The depth stop positions the blade  $\frac{1}{4}$ " from the cast iron table support. The depth stop is factory set and should never need adjustment.

#### Maintaining Maximum Cutting Capacity

**WARNING: To avoid injury from unexpected starting or electrical shock, do not plug the power cord into a source of power during unpacking and assembly. This cord must remain unplugged whenever you are working on the saw.**

Unplug the saw before any adjustment is attempted.

This tool is factory set to provide maximum cutting capacity for the 10" saw blade provided. When the diameter of the blade has been reduced due to sharpening, it may be necessary to adjust depth stop to provide maximum cutting capacity. When a new blade is installed, it is necessary to check the clearance of the blade to the turn table structure.

1. To adjust the depth stop use an adjustable wrench and loosen the hex nut at the rear of the miter saw arm.
2. Use a flat blade screwdriver to adjust the depth stop adjusting bolt. The saw blade is lowered by turning the bolt counterclockwise and raised by turning the bolt clockwise.

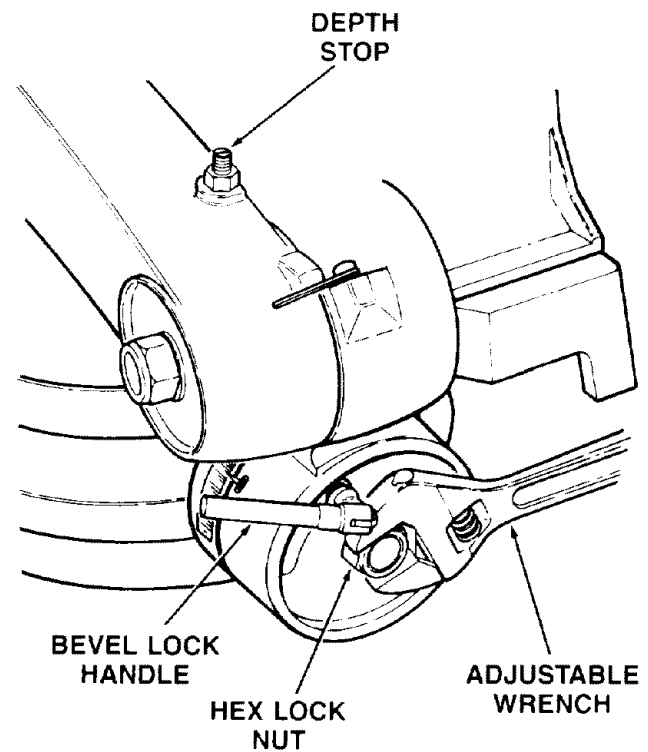

Assembly and Alignment

3. Lower the blade into the slot of the turn table. Check blade clearance and maximum cutting distance (distance from fence where blade enters) to front of turn table slot. Readjust if necessary.

**WARNING: Do not start the miter saw without checking for interference between the blade and the turn table structure. Damage could result to the blade if it strikes the turn table structure during operation of the saw.**

4. Tighten the hex nut with an adjustable wrench while carefully holding the depth stop adjusting bolt with the flat blade screwdriver so it will not turn while tightening hex nut.

## Fence Positions

The miter saw has two fence positions. The front fence position is used for workpieces up to standard 2 x 4 for cut off and bevel operation, floor and ceiling moldings, and door casings. The rear fence position is used for cut off and bevel operation for a standard 2 x 6 workpiece.

Standard 2 x 4 measures 1½" x 3½"

Standard 2 x 6 measures 1½" x 5½"

The base on either side of the work table has two sets of holes for locating the fence. To change the fence position, remove the two fence lock handles. Put the fence in the other fence position and install the fence lock handles.

The rear fence position is designed to slide side to side when the miter setting is changed. This feature lets the fence move to provide maximum support for the workpiece. If it is necessary to change the miter cut in the rear position, first loosen the fence lock handles. Release the miter lock handle and move it to the desired miter angle. Tighten the miter lock handle and the fence lock handles.

**CAUTION: Do not try to change the miter position while the fence is in the rear fence position before loosening the fence lock handles. You might damage the fence alignment arm.**

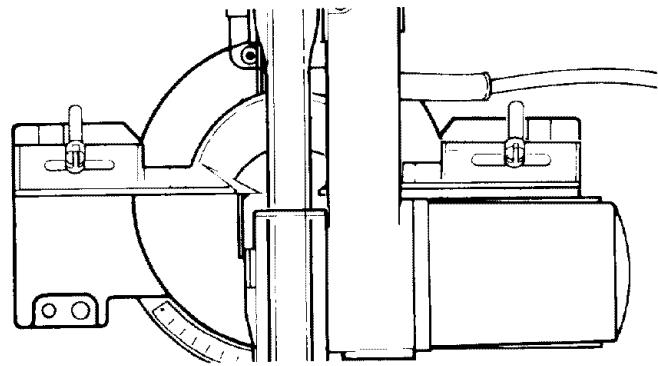

FRONT FENCE POSITION

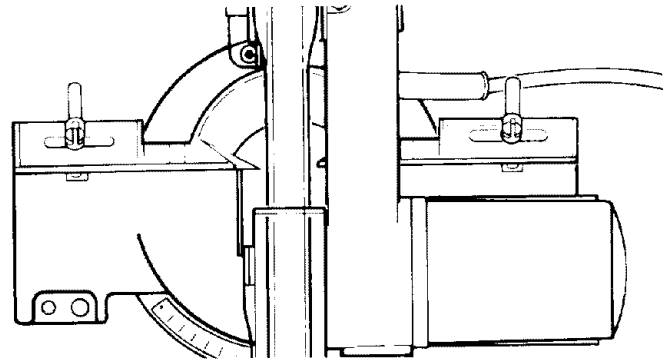

REAR FENCE POSITION

## On/Off Trigger Switch

To prevent the trigger from being accidentally engaged, a lock-off button is provided. To start the tool, press in the lock-off button and squeeze the trigger. Release the trigger to stop the miter saw.

## Removing or Installing the Blade

**WARNING: To avoid injury from a thrown workpiece or thrown pieces of blade, do not use a blade larger or smaller than 10" diameter.**

**WARNING: To avoid injury from unexpected starting, unplug the saw whenever you are removing or installing the blade.**

1. Unplug the saw from the outlet.
2. Loosen the screw holding the lower guard mounting plate to the upper guard with phillips screwdriver.
3. Lift the lower guard up and tilt the lower guard assembly back so the arbor screw is exposed.
4. Find the arbor lock between the upper guard and the miter saw handle. Place a ½" box end wrench over arbor screw.
5. Press the arbor lock and hold it in firmly while turning the wrench **clockwise**. The arbor lock will engage after some turning of the wrench.
6. Remove the arbor screw, arbor washer, outer blade collar, and the blade.

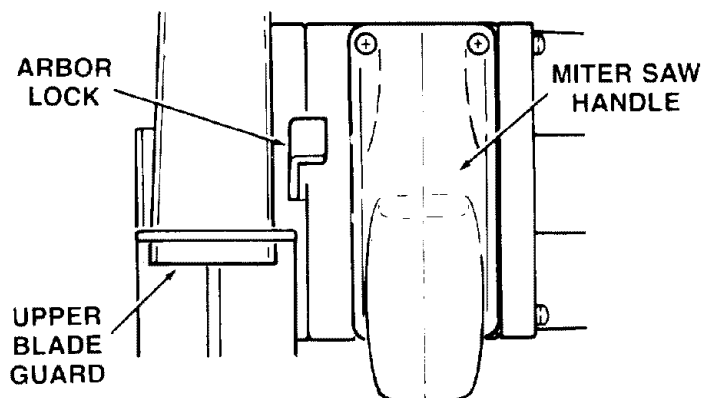
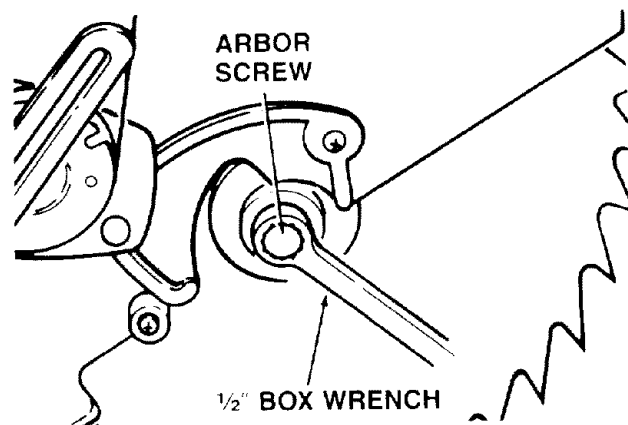

**NOTE:** Pay attention to pieces removed, noting their position and direction they face (see illustration). Wipe the blade collars clean of any sawdust before installing the new blades.

8. Install the new 10" blade (see recommended accessory list). Make sure the rotation arrow on the blade matches the clockwise rotation arrow on the upper guard.
9. Install the outer blade collar, arbor washer and arbor screw. Press the arbor lock and turn the 1/2" wrench counter clockwise to secure the blade. Tighten arbor screw securely.
10. Lower the lower blade guard until the slot in mounting plate rests all the way down on the locking screw. Tighten the screw with phillips screwdriver.

**DANGER:** Never use saw without mounting plate securely in place. It keeps the arbor screw from falling out if it accidentally loosens, and prevents the spinning blade from coming off the machine.

11. Be sure the arbor lock is released so the blade turns freely.

**NOTE:** The arbor lock can be damaged by improper use. If the arbor lock will not hold, lower the blade down on to a scrap piece of wood positioned against the fence. This will serve as an alternate locking means.

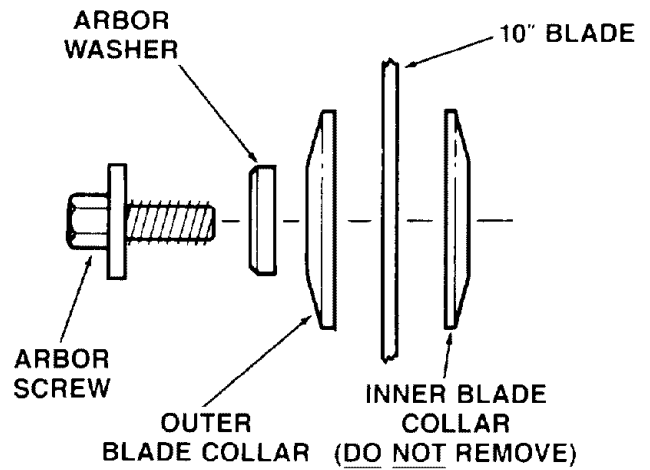

**WARNING:** After installing a new blade, make sure the blade clears the table slot at the 0° and 45° bevel positions. Lower the blade into the lower table and check for any contact with the base or turn table structure.

If blade contacts turn table, refer to assembly and alignment, step two, for adjustment.

If blade bottoms out on turn table structure, refer to assembly and alignment, depth stop section for adjustment.

## MOUNTING THE SAW

**WARNING:** To avoid injury from unexpected saw movement:

- a. Before moving the saw, lock the miter, bevel and power-head positions. Unplug electric cord.
- b. To avoid back injury, get help when you need to lift the saw more than 10 inches. Hold the tool close to your body. Bend your knees so you can lift with your legs, not your back. Lift by using the hand-hold areas at the bottom of the base.
- c. Never carry the miter saw by the power cord or the plastic handle. Carrying the tool by the power cord could cause damage to the insulation or the wire connections resulting in electric shock or fire.
- d. Place the saw so other people cannot stand behind it. Thrown debris could injure people in its path.
- e. Place the saw on a firm, level surface where there is plenty of room for handling and properly supporting the workpiece.
- f. Support the saw so the table is level and the saw does not rock.
- g. Bolt or clamp the saw to its support.

Place the saw in the desired location either on a work bench or the recommended leg set. The base of the saw has four holes to mount the miter saw (see illustration). If the saw is to be used in one location, fasten it to the work bench or leg set.

(DUST BAG: REMOVED FOR CLARITY)

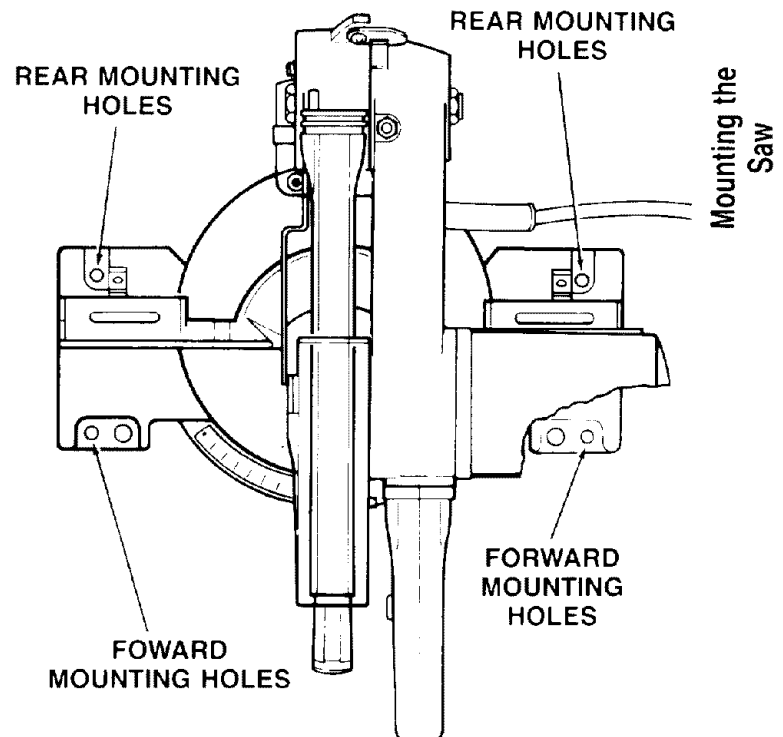

**NOTE:** Fence has been moved forward for access to rear mounting holes.

If the saw is to be used in a portable application, mount the saw to a  $\frac{3}{4}$ " piece of plywood. The mounting board can then be clamped down to prevent it from tipping.

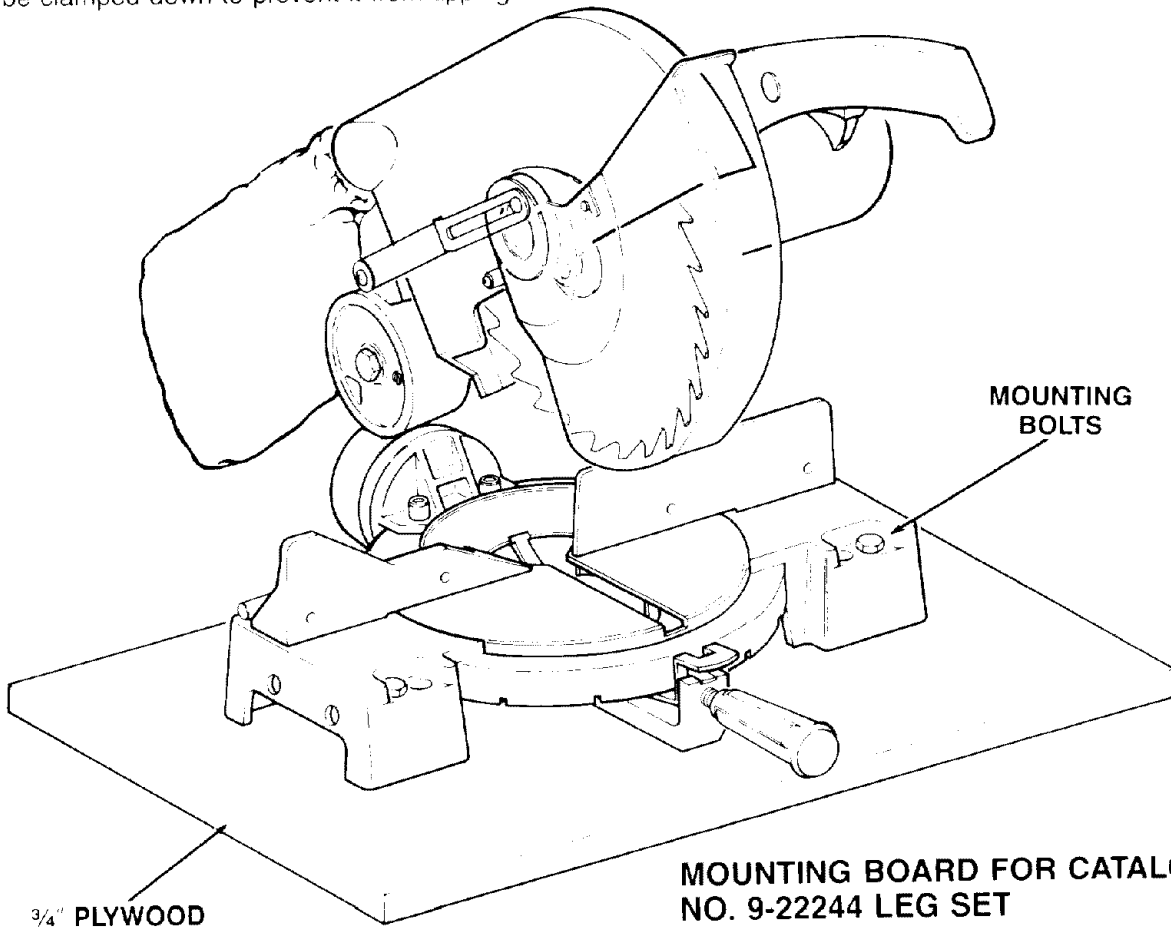

**MOUNTING BOARD FOR CATALOG NO. 9-22244 LEG SET**

**NOTE:** Attach the mounting board to the leg set first. Then mount the miter saw to the mounting board using the recommended hardware (not included)

**CATALOG NO. 9-22246 LEG SET MOUNTING HOLES FOR MODEL 113.234600 MITER SAW**

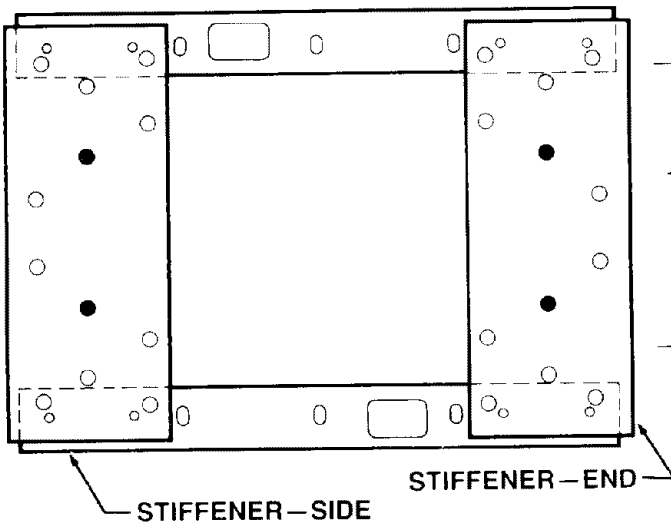

Attach miter saw to holes indicated

- Recommended mounting hardware (not included)
- 4- $\frac{5}{16}$ -18 x 3 hex head bolts
  - 4- $\frac{5}{16}$  flat washers
  - 4- $\frac{3}{16}$  lock washers
  - 4- $\frac{5}{16}$  hex nuts

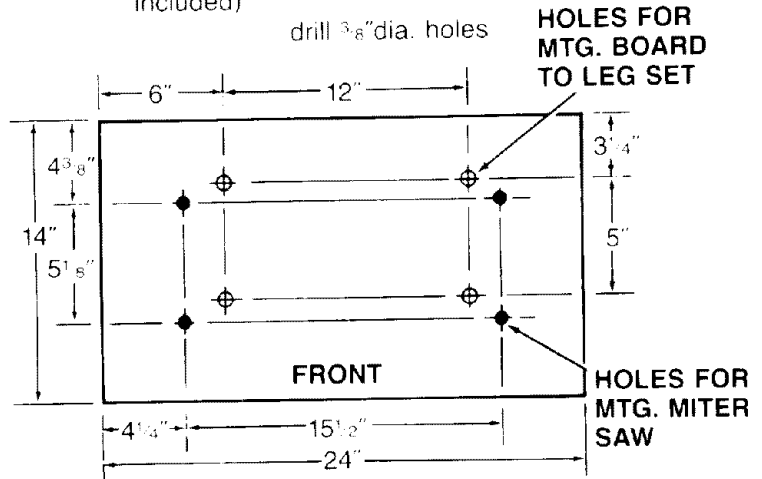

- Recommended hardware (not included)
- Mounting board to legset
  - 4- $\frac{5}{16}$ -18 x  $\frac{1}{2}$  hex head bolts
  - 4- $\frac{5}{16}$  flat washers
  - 4- $\frac{3}{16}$  lock washers
  - 4- $\frac{5}{16}$  hex nuts

- Mounting miter saw to mounting board
- 4- $\frac{5}{16}$ -18 x  $3\frac{1}{2}$  hex head bolts
  - 4- $\frac{5}{16}$  flat washer
  - 4- $\frac{3}{16}$  lock washer
  - 4- $\frac{5}{16}$  hex nuts

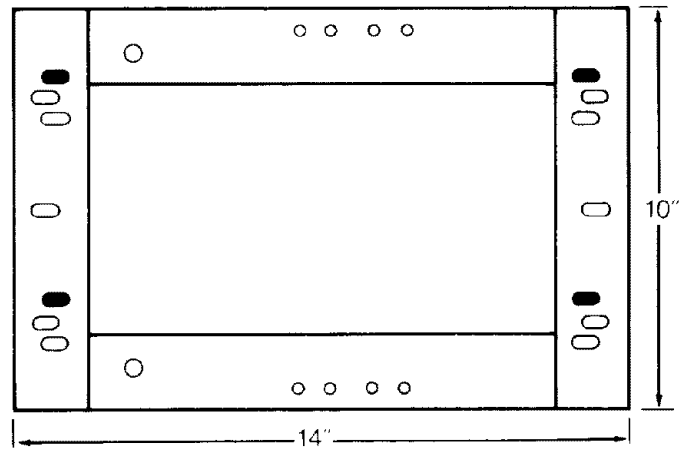
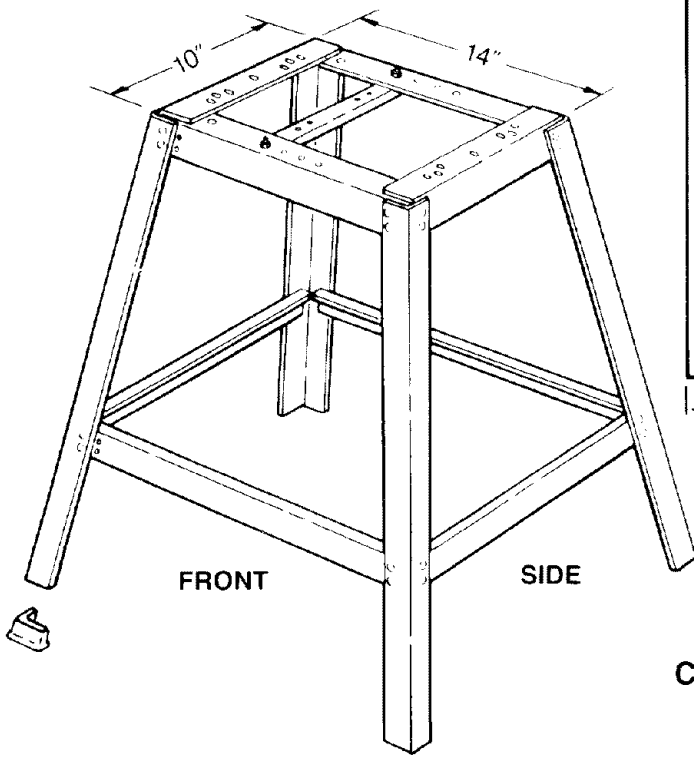

Attach mounting board to holes indicated.

**CATALOG NO. 9-22244 LEG SET**

## BEFORE USING THE MITER SAW:

**WARNING:** To avoid mistakes that could cause serious, permanent injury, do not plug the miter saw in until the following steps are completed.

- Assembly and alignment. (See pages 9-13 ).
- The saw is properly mounted. (See pages 13-15).
- Learn the use and function of the ON-OFF switch, upper and lower blade guards, handle latch, bevel clamp, cover plate stop screw, and fence clamps. (See page 8).
- Review and understand all safety instructions and operating procedures in this manual.
- Review the maintenance methods for this miter saw. (See page 23).

### To avoid injury or death from electrical shock:

- Make sure your fingers do not touch the plug's metal prongs when plugging or unplugging the miter saw.

## BEFORE EACH USE:

### Inspect your miter saw.

**DISCONNECT THE MITER SAW.** To avoid injury from accidental starting, unplug the saw, before changing the setup, changing the blade or adjusting anything.

Compare the direction of rotation arrow on the guard to the direction arrow on the blade. The blade teeth should always point downward at the front of the saw.

Tighten the arbor screw.

Tighten the cover plate stop screw.

### CHECK DAMAGED PARTS. Check for:

- Alignment of moving parts,
- Damaged electric cords.
- Binding of moving parts,
- Broken parts,
- Stable mounting,
- Function of arm return spring and lower guard: Push the arm all the way down, then let it rise up until it stops by itself. Check the lower guard to see if it closed fully. If it did not, follow the instructions in the Trouble Shooting section.
- Other conditions that may affect the way the miter saw works.

**KEEP GUARDS IN PLACE,** in working order, and in proper adjustment.

If any part is missing, bent, or broken in any way, or any electrical parts don't work, turn the saw off and unplug it. **REPLACE** damaged, missing, or failed parts before using the saw again.

**MAINTAIN TOOLS WITH CARE.** Keep the miter saw clean for best and safest performance. Follow instructions for lubricating. **DON'T** put lubricants on the blade while it's spinning.

**REMOVE ADJUSTING KEYS AND WRENCHES** from tool before turning it on.

### To avoid injury from jams, slips or thrown pieces:

- **USE ONLY RECOMMENDED ACCESSORIES.** (See page 23). Consult this Owner's manual for recommended accessories. Follow the instructions that come with the accessories. The use of improper accessories may cause risk of injury to persons.
- Choose the right 10" inch diameter blade for the material and the type of cutting you plan to do.
- Make sure the blade is sharp, undamaged and properly aligned. With the saw unplugged, push the power-head all the way down. Hand spin the blade and check for clearance. Tilt the power-head to 45 degree bevel and repeat the check. If the blade hits anything, make the adjustments shown in the Maintaining Maximum Cutting Capacity section.
- Make sure the blade and arbor collars are clean.
- Make sure the arbor collar's recessed sides are facing the blade.
- Using a 1/2-inch box wrench, make sure the arbor cap screw is firmly hand tightened.
- Make sure all clamps and locks are tight and no parts have excessive play.
- **KEEP WORK AREA CLEAN.** Cluttered areas and benches invite accidents. Floor must not be slippery.

To avoid burns or other fire damage, never use the miter saw near flammable liquids, vapors or gases.

## Plan ahead to protect your eyes, hands, face, ears.

**KNOW YOUR MITER SAW.** Read and understand the owner's manual and labels affixed to the tool. Learn its application and limitations as well as the specific potential hazards peculiar to this tool.

To avoid injury from accidental contact with moving parts, don't do layout, assembly, or setup work on the miter saw while any parts are moving.

**AVOID ACCIDENTAL STARTING.** Make sure switch is "OFF" before plugging miter saw into a power outlet.

### Plan your work.

**USE THE RIGHT TOOL.** Don't force tool or attachment to do a job it was not designed to do. Use a different tool for any workpiece that can't be held in a solidly braced, fixed position.

**CAUTION:** This machine is not designed for cutting ferrous metals (steel, iron and iron based metals). Use this miter saw to cut only wood, wood like products or soft metals like aluminum. Other materials may shatter, bind on the blade, or create other dangers.

**CAUTION:** When cutting any metals, sparks or hot fragments could cause a fire. To avoid this, disconnect any dust collecting hose from the miter saw, and remove all traces of wood dust from inside dust traps in the miter saw.



## Dress for safety.

Any power miter saw can throw foreign objects into the eyes. This can cause permanent eye damage. Wear safety goggles (not glasses) that comply with ANSI Z87.1 (shown on package). Everyday eyeglasses have only impact resistant lenses. They are not safety glasses. Safety goggles are available at Sears retail catalog stores. Glasses or goggles not in compliance with ANSI Z87.1 could seriously hurt you when they break.

- Do not wear loose clothing, gloves, neckties or jewelry (rings, wrist watches) They can get caught and draw you into moving parts.
- Wear nonslip footwear.
- Tie back long hair.
- Roll long sleeves above the elbow.
- Noise levels vary widely. To avoid possible hearing damage, wear ear plugs or muffs when using miter saw for hours at a time.
- For dusty operations, wear a dust mask along with the safety goggles.

## Inspect your workpiece.

- Make sure there are no nails or foreign objects in the part of the workpiece to be cut.

## Plan your work to avoid THROWBACKS—when the workpiece binds on the blade and is torn from your hands.

Plan the way you will hold the workpiece from start to finish:

Avoid awkward operations and hand positions where a sudden slip could cause fingers or hand to move into the blade.

**DON'T OVERREACH.** Keep good footing and balance.

Keep your face and body to one side, out of line with a possible throwback.

## Never cut FREEHAND:

- Brace your workpiece solidly against the fence and table top so it will not rock or twist during the cut.
- Make sure there's no debris between the workpiece and its supports.
- Make sure no gaps between the workpiece, fence and table will let the workpiece shift after it is cut in two.
- Keep the cut off piece free to move sideways after it's cut off. Otherwise, it could get wedged against the blade and thrown violently.
- Clear everything except the workpiece and related support devices off the table before turning the miter saw on.
- **SECURE WORK.** Use clamps or a vise to help hold the work when it's practical.

## Use extra caution with large, very small or awkward workpieces:

- Use extra supports (tables, saw horses, blocks, etc.) for any workpieces large enough to tip when not held down to the table top.
- **NEVER** use another person as a substitute for a table extension, or as additional support for a workpiece that is longer or wider than the basic miter saw table, or to help feed, support or pull the workpiece.
- Do not use this saw to cut pieces too small to let you easily hold the work while you keep the thumb side of your index (pointer) finger against the outside edge of the fence.
- When cutting irregularly shaped workpieces, plan your work support so it will not slip, pinch the blade and be torn from your hands. A piece of molding, for example, must lie flat or be held by a fixture or jig that will not let it twist, rock or slip while being cut.
- Properly support round material such as dowel rods, or tubing. They have a tendency to roll while being cut, causing the blade to "bite". To avoid this, always use a fixture designed to properly hold your workpiece.

**WARNING:** If planning to cut aluminum or other non-ferrous metals: Under adverse conditions, the blade can grab and throw the workpiece suddenly and unexpectedly. To avoid injury, follow all applicable safety instructions, as you normally would, and:

- Use only sawblades specifically recommended for non-ferrous metal cutting.
- Do not cut metal workpieces that must be hand held. Use auxiliary clamps or other equipment as needed.
- Cut non-ferrous metals only if you are experienced or under the supervision of an experienced person.

## WHENEVER SAW IS RUNNING.

**WARNING:** Don't let familiarity (gained from frequent use of your miter saw) cause a careless mistake. A careless fraction of a second is enough to cause a severe injury.

Before starting your cut, watch the miter saw while it runs. If it makes an unfamiliar noise or vibrates a lot, stop immediately. Turn the miter saw off. Unplug the miter saw. Do not restart until finding and correcting the problem.

**KEEP CHILDREN AWAY.** Keep all visitors a safe distance from the miter saw. Make sure bystanders are clear of the miter saw and workpiece.

Never confine the piece being cut off. Never hold it, clamp it, touch it, or use length stops against it while the blade is spinning. It must be free to move sideways on its own. If confined, it could get wedged against the blade and thrown violently.

Let the blade reach full speed before cutting.

**DON'T FORCE TOOL.** It will do the job better and safer at its designed rate. Feed the blade into the workpiece only fast enough to let it cut without bogging down or binding.

**Before freeing any jammed material:**

- Turn switch "OFF".
- Unplug the miter saw.
- Wait for all moving parts to stop.

**After finishing a cut:**

- Keep holding the power head down.
- Release the switch, and wait for all moving parts to stop before moving your hands.
- If blade doesn't stop within 6 seconds, unplug the saw and follow the instructions in the Trouble Shooting section for fixing the blade brake before using the saw again.

**BEFORE LEAVING THE SAW:**

**NEVER LEAVE TOOL RUNNING UNATTENDED.** Turn power off. Wait for all moving parts to stop.

Make workshop child-proof. Lock the shop. Disconnect master switches. Remove the yellow switch key. Store it away from children and others not qualified to use the tool.

**WARNING: For your convenient use, your saw has a blade brake. The brake is not a safety device. Never rely on it to replace proper use or the guard on your saw. If the blade does not stop within 6 seconds, unplug the saw and follow the instructions in the Trouble Shooting section for fixing the brake before using saw again.**

**Body and Hand Position**

Proper positioning of your body and hands when operating the miter saw will make cutting easier and safer. Never place hands near cutting area. Place hand at least 4" from path of blade. Hold workpiece firmly to the fence to prevent movement toward the blade. Keep hands in position until trigger has been released and the blade has completely stopped. Before making a cut, make a "dry run" with the power off so you can see the path of the blade.

**WARNING: Do not try to cut short pieces. You cannot properly support the workpiece and keep your hold down hand the required distance from the blade.**

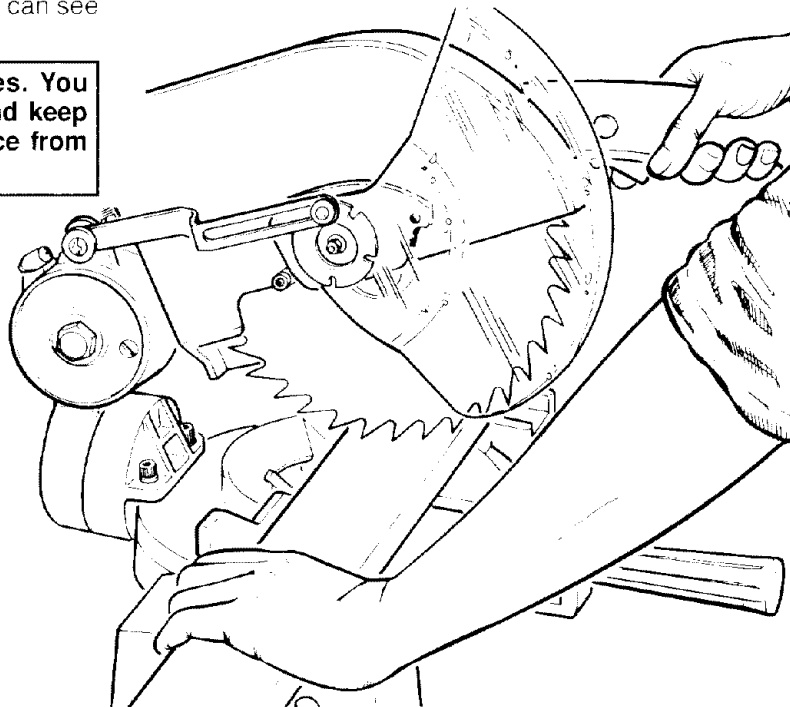

Basic Saw Operations

### Miter Cut

When a miter cut is required, move the saw to the desired angle. Do not stand in front of the saw table. Move with the handle to the miter angle to make the cut.

**NOTE:** Remember to loosen the fence lock handles before changing the miter angle with the fence in the rear position.

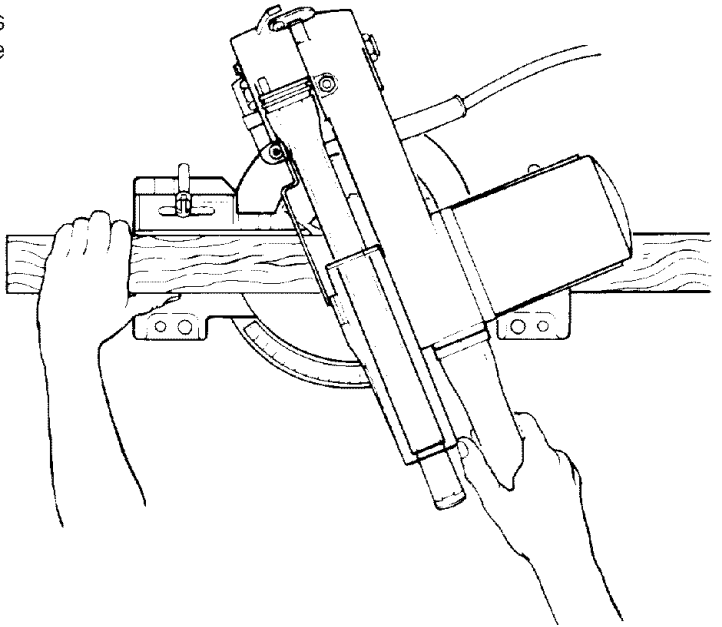

---

### Bevel Cut

When a bevel cut is required, tilt the blade to desired bevel angle. Stand to the left side of the handle to make the cut.

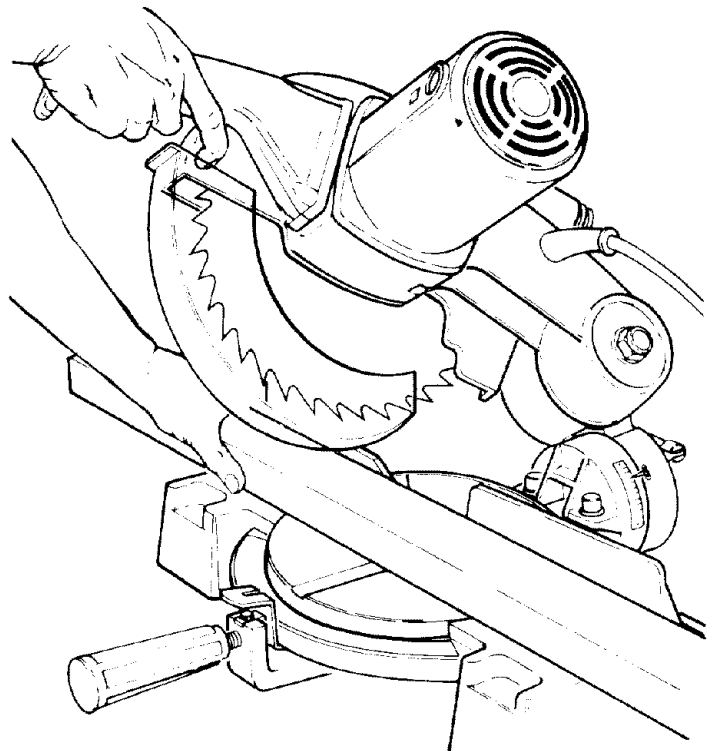

### Compound Cut

When a compound cut is required, select the correct bevel and miter position. Move with the handle to the miter angle to make the cut. If the fence is in the rear position, loosen the two lock handles before changing the miter angle.

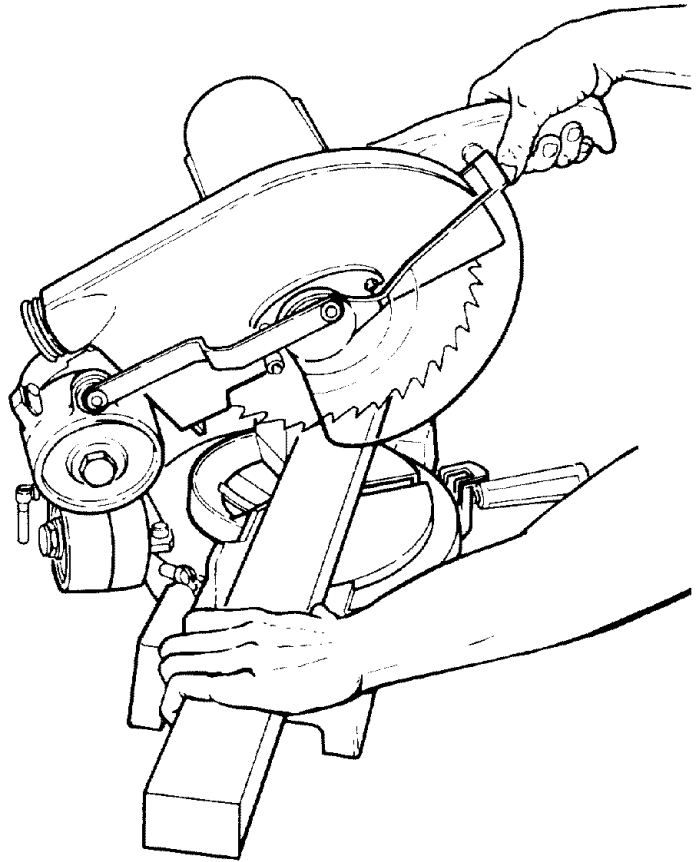

---

### Cutting Bowed Material

Before cutting a workpiece, check to make sure it is not bowed. If it is bowed the workpiece must be positioned and cut as illustrated. Do not position workpiece incorrectly or try to cut the workpiece without the support of the fence. This will cause pinching of the workpiece on the blade. The workpiece could suddenly jump or move and your hand could hit the blade.

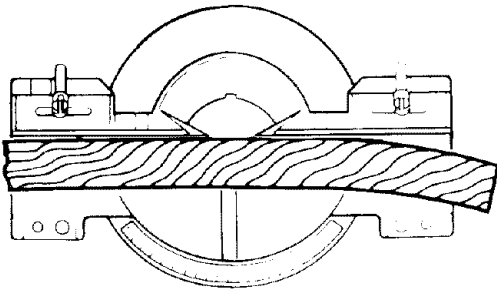

**CORRECT**

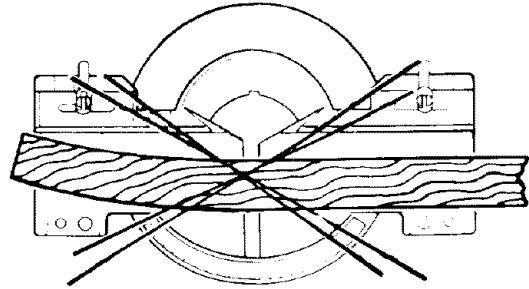

**INCORRECT**

## Workpiece Support

Long pieces need extra supports. The supports should be placed along the workpiece so the workpiece does not sag and your hand holding the workpiece is positioned 4" or more from the blade path. The support should let the workpiece lay flat on the base and work table during the cutting operation.

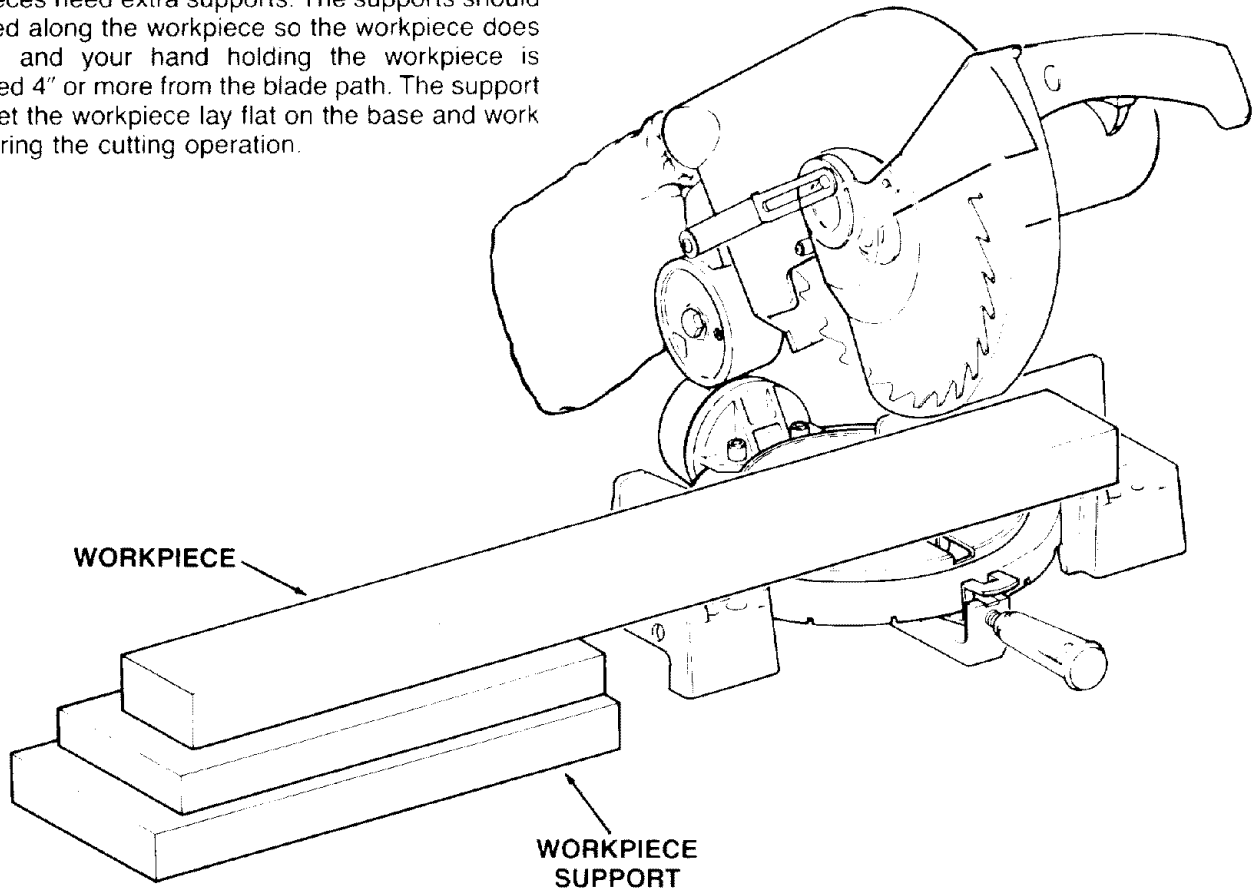

## Auxiliary Fence

Certain types of molding need a fence face extension due to the size and position of the workpiece. Holes are provided in the fence to attach an auxiliary fence made of straight wood typically 1/2 inch thick by 3 inches high by 20 inches long. The auxiliary fence is used with the saw in the 0° bevel position. If a bevel cut is desired, the auxiliary fence will have to be removed.

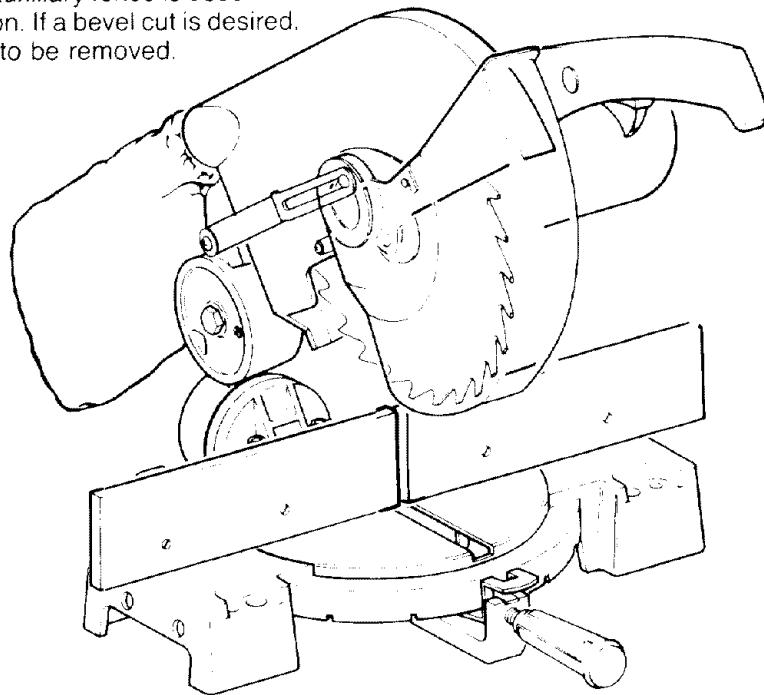

### Filler Blocks for Cutting Crown Moldings

The majority of crown moldings have contact surfaces of 52° and 38° to the rear surface of the molding. When joining the face of the filler block these angles must be maintained. The following illustrations show two methods that can be used when cutting crown moldings depending on how the filler block is attached to the fence.

When the filler blocks are attached with the face of the filler blocks pointing upwards, the molding must be

placed on the table upside down.

When the filler blocks are attached to the fence with the face of the filler blocks pointing downwards, the molding must be placed on the table right side up. This is the same position as it would be when nailed between the ceiling and wall.

Make 2 filler blocks 10 inches long. Fasten blocks securely to fence. For block face pointing downward, you may need to drill new fastener holes in the fence.

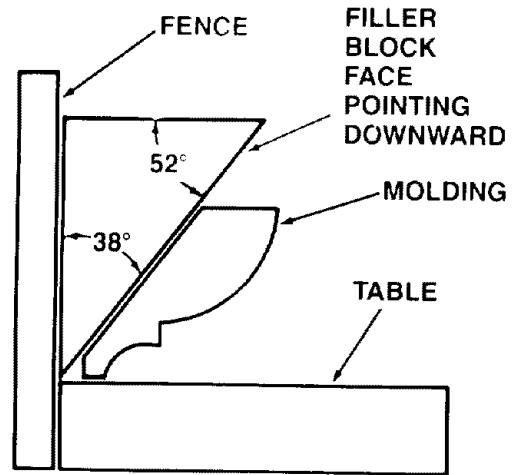
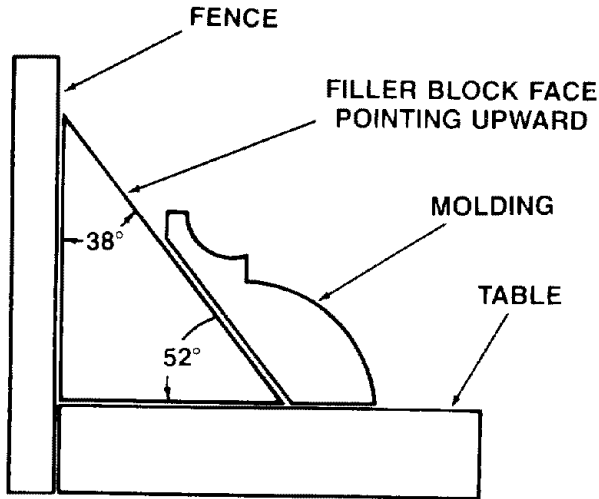

### Vertical Bevel Cutting

To make a miter cut in a 2 x 4 workpiece (actual 1<sup>5</sup>/<sub>8</sub>" x 3<sup>1</sup>/<sub>2</sub>") in the vertical position (on edge) a spacer, such as the auxiliary fence described on the previous page, is required. Fence is located in the front fence position.

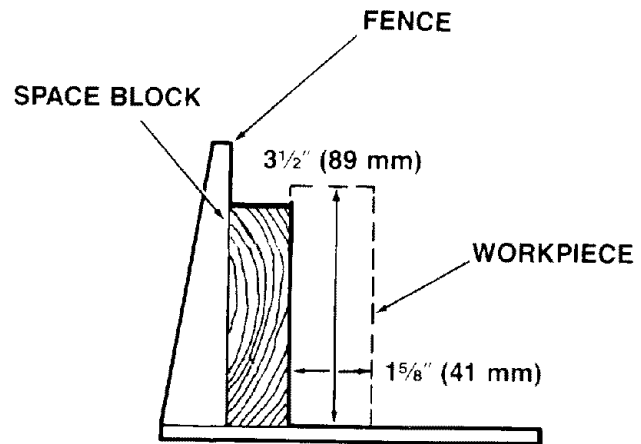

# maintenance and lubrication

## Maintenance

Always unplug the power cord before any maintenance check on this saw.

**DANGER: Never put lubricants on the blade while it's spinning.**

**WARNING: To avoid injury from unexpected starting or electrical shock, unplug the power cord before working on the saw.**

**WARNING: For your safety, this saw is double insulated. To avoid electrical shock, fire or injury, use only parts identical to those identified in the parts list. Reassemble exactly as original assembly to avoid electrical hazards.**

## Replacing Carbon Brushes

The carbon brushes furnished will last approximately 50 hours of running time or 10,000 on/off cycles. Replace both carbon brushes when either has less than 1/4" length of carbon remaining. To inspect or replace first unplug the saw. Then remove the black plastic cap on the side of the motor (caution, this cap is spring loaded by the brush assembly). Then pull out the brush. Repeat for the other side. To reassemble reverse the procedure. The ears on the metal end of the brush assembly go in the same hole the carbon part fits into. Tighten the cap snugly but do not overtighten.

**NOTE:** To reinstall the same brushes, first make sure the brushes go back in the way they came out. This will avoid a break in period that reduces performance and increases wear.

## Lower Blade Guard

Do not use the saw without the lower guard. The lower blade guard is attached to the saw for protection. Should the lower guard become damaged, do not use the saw until damaged guard has been replaced. Develop a regular check to make sure the lower guard is working properly. Clean the lower guard of any dust or build up with a damp cloth.

**CAUTION: Do not use solvents on the guard. They could make the plastic "cloudy" and brittle.**

**WARNING: When cleaning lower guard unplug the saw from the outlet to avoid unexpected start-up.**

## Saw Dust

Periodically, sawdust will accumulate under the work table and base. This could cause difficulty in the movement of the work table when setting up a miter cut. Frequently blow out or vacuum up the sawdust.

**WARNING: If blowing sawdust, wear proper eye protection to keep debris from blowing into eyes.**

## Recommended Accessories

**WARNING: To avoid injury from unsafe accessories, use only accessories shown on the recommended accessories list in this manual.**

Prohibited Accessories—The use of any cutting tool except 10" saw blades which meet the requirement under recommended accessories is prohibited. Do not use accessories such as shaper cutters or dado sets. Ferrous metal (metal with iron in it) cutting and the use of abrasive wheels are prohibited. See **DANGER NOTE** (BASIC SAW OPERATIONS) if planning to saw non-ferrous metal.

Leg Sets	9-22244
Carbide-Tipped Blades:	9-22246
Trim Saw	See Catalog
Cut-Off	See Catalog
Combination	See Catalog
Plywood/Particle Board	See Catalog
Non-Carbide Tipped Blades:	
Cross Cut/Plywood	See Catalog
Combination	See Catalog
Miter Saw Accessory Pack	9-23469

## Basic Blade Requirements

- 10" Diameter
- Blades marked for 5,500 RPM or higher.
- 5/8" Arbor Hole

## Lubrication

All the motor bearings in this tool are lubricated with a sufficient amount of high grade lubricant for the life of the unit under normal operating conditions, therefore, no further lubrication is required. (See below.)

## Infrequent Lubrication as Required:

1. Lubrication of arm pivot for free movement.
  - a. By loosening nut and applying oil to washer and to contact face (minor).
  - b. Dis-assembly means required to grease pivot bolt and contact faces (major).

**NOTE:** Disassembly should be done by an authorized service technician. Removal of the upper guard and the bolt stop is necessary before pivot can be disassembled. Pay close attention to the spring-end positions in the castings....mark with chalk to avoid later confusion.

2. Lubrication of mechanism which pivots lower guard: Use light household oil (sewing machine oil) on metal-to-metal or metal-to-plastic guard contact areas as required for smooth, quiet operation. Avoid excess oil, to which sawdust will cling

## TROUBLE SHOOTING GUIDE - MOTOR

PROBLEM	PROBABLE CAUSE	SUGGESTED CORRECTIVE ACTION
<b>Brake does not stop blade within 2–3 seconds.</b>	1. Brushes not seated or lightly sticking.	– Inspect/clean/replace brushes (see maintenance section).
	2. Motor brake winding—overheated from use of not-recommended accessory or rapid on/off cycling.	– Use a recommended blade. – Let cool down.
	3. Arbor screw loose.	– Retighten
	4. Other.	– Authorized service. Check motor brake winding, switch, condition of commutator.
<b>Motor does not start.</b>	1. Fuse.	– 15-Amp time delay fuse, or CKT. breaker.
	2. Brushes worn.	– See "Maintenance," page 21.
	3. Other.	– Authorized service.
<b>Brush sparking when switch released.</b>	1. Normal—automatic brake working properly.	

## TROUBLE SHOOTING GUIDE - GENERAL

PROBLEM	PROBABLE CAUSE	SUGGESTED CORRECTIVE ACTION
<b>Blade hits table.</b>	1. Misalignment.	– See Assembly and Alignment, page 10.
	2. Damaged depth stop.	– Get authorized Sears Service.
<b>Angle of cut not accurate.</b>	1. Misalignment.	– See Assembly and Alignment, page 10.
<b>Can't move miter adjustment.</b>	1. Fence in rear position and clamp tight.	– Loosen fence clamps. Retighten before starting next cut.
	2. Sawdust under table.	– Vacuum or blow out dust. <b>WEAR EYE PROTECTION</b>
<b>Power-head wobbles.</b>	1. Loose pivot points.	– See Assembly and Alignment, Step 4, page 12.
<b>Power-head won't fully rise.</b>	1. Pivot misadjustment.	– See Assembly and Alignment, Step 4, page 12.
	2. Part failure.	– Get authorized Sears Service.
	3. Pivot spring not replaced properly after service.	– Get authorized Sears Service.
<b>Blade binds, jams, burns wood.</b>	1. Improper operation.	– See Basic Saw Operation, page 16.
	2. Dull blade.	– Replace or sharpen blade.
	3. Improper blade	– Replace with 10" diameter blade designed for the material being cut.
	4. Warped blade.	– Replace blade.
<b>Tool vibrates or shakes.</b>	1. Saw blade not round.	– Replace blade.
	2. Saw blade damaged.	– Replace blade.
	3. Saw blade loose.	– Tighten arbor screw.
	4. Other.	– Get authorized Sears Service.



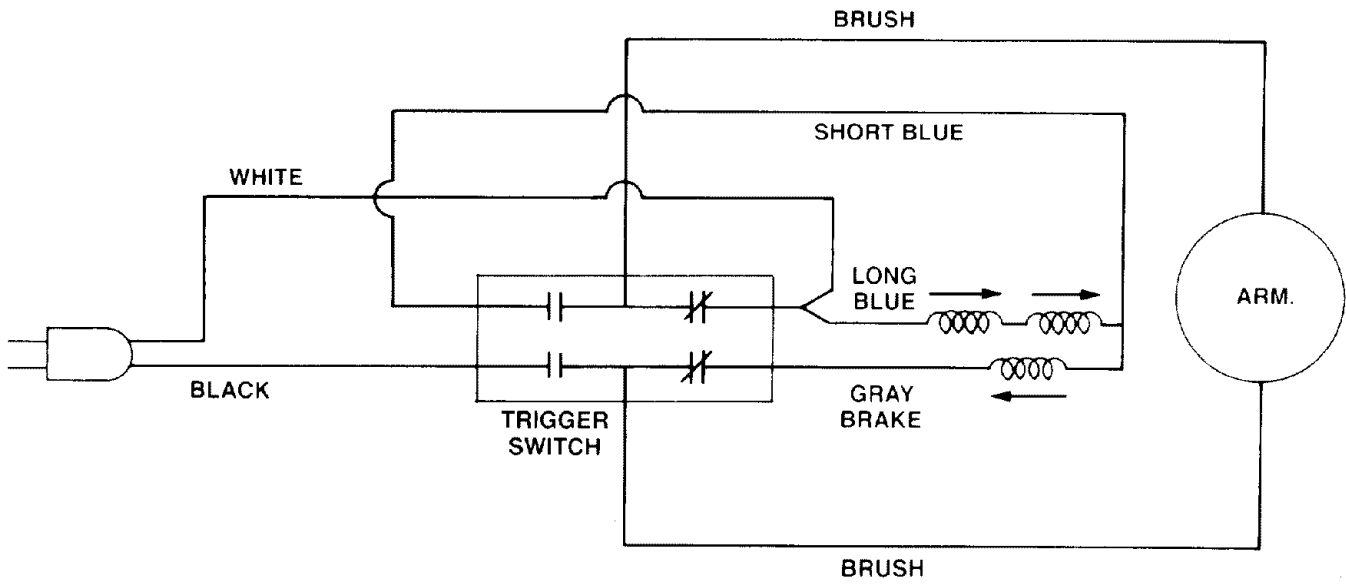

CIRCUIT DIAGRAM

NOTES

---

---

---

---

---

---

---

---

---

---

---

---

---

---

---

---

---

---

---

---

---

---

---

---

**PARTS LIST FOR CRAFTSMAN 10" COMPOUND MITER SAW  
MODEL NO. 113.234600**

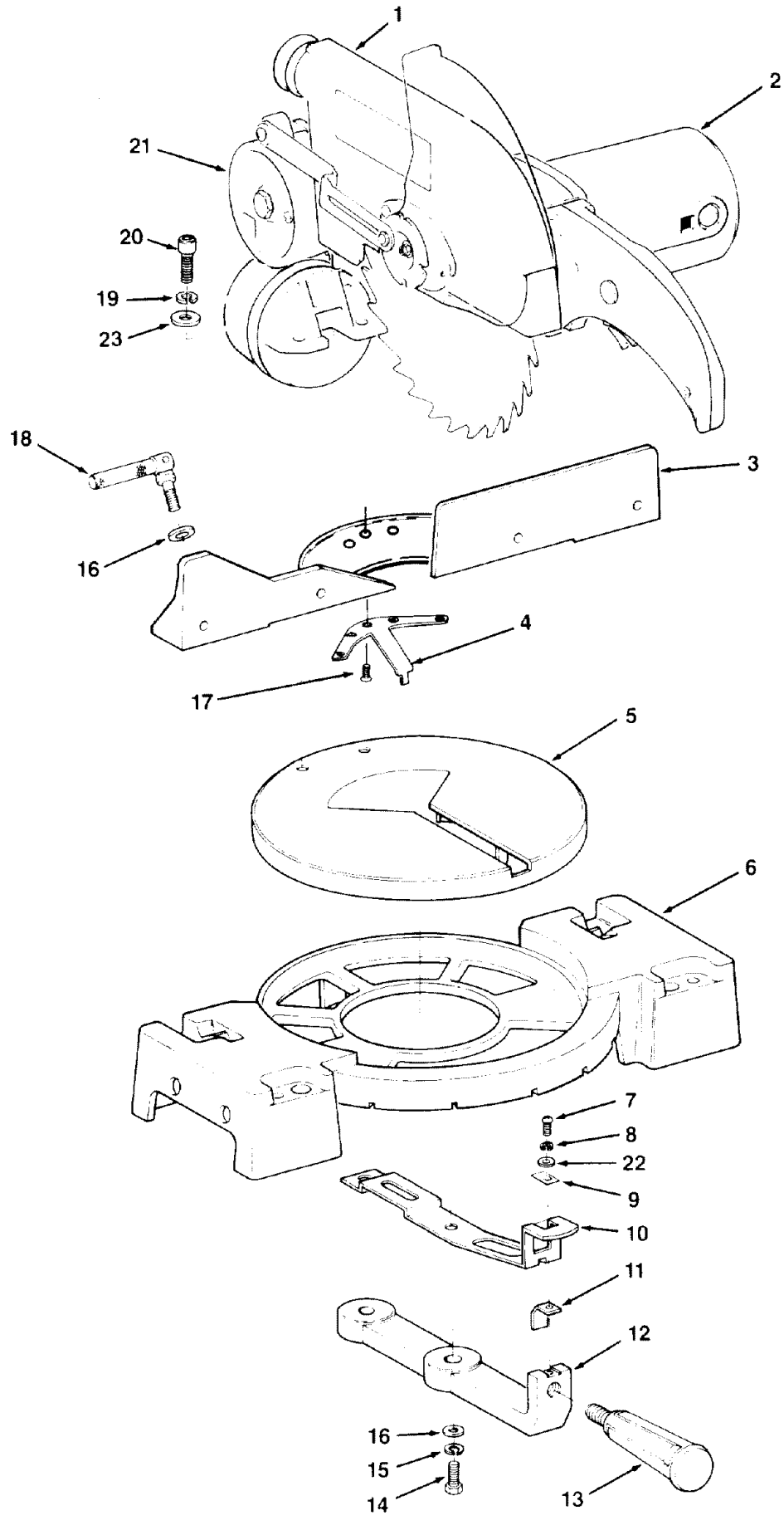

# repair parts

## PARTS LIST FOR CRAFTSMAN 10" COMPOUND MITER SAW MODEL NO. 113.234600

Always order by Part Number—Not by Key Number

FIGURE 1

Key No.	Part No.	Description	Key No.	Part No.	Description
1	—	Blade Guard Asm. (see Fig. 4)	13	816669	Handle-Miter
2	—	Motor Asm. (see Fig. 2)	14	STD523108	* Bolt-Hex HD. 5/16-18 x 7/8
3	821664	Fence	15	STD551131	* Lockwasher 5/16
4	820010	Arm-Fence	16	STD551031	* Washer 11/32 x 11/16 x 1/16
5	816673-1	Table	17	809727	* Screw Flat HD. Type "T" 8-32 x 5/8
6	816678	Base (Includes Scale)	18	816863-1	Clamp-Bolt
7	STD510802	* Screw Pan HD. 8-32 x 5/16	19	STD551137	* Lockwasher 3/8
8	STD551108	* Lockwasher #8	20	141594-44	* Screw Soc HD. Cap 3/8-16 x 1 1/2
9	816716	Indicator-Miter	21	—	Pivot Asm. (see Fig. 3)
10	816691	Spring-Index	22	STD851004	* Washer 4 x 10 x 0.8mm
11	816690	Plate-Clamp	23	817182	Washer 10 x 19 x 1.8mm
12	816685	Arm-Miter			

\* Standard Hardware Item—May Be Purchased Locally.

**⚠ WARNING: These Items Are Important To The Safety Of This Tool. Do Not Substitute Common Parts.**

**PARTS LIST FOR CRAFTSMAN 10" COMPOUND MITER SAW  
MODEL NO. 113.234600**

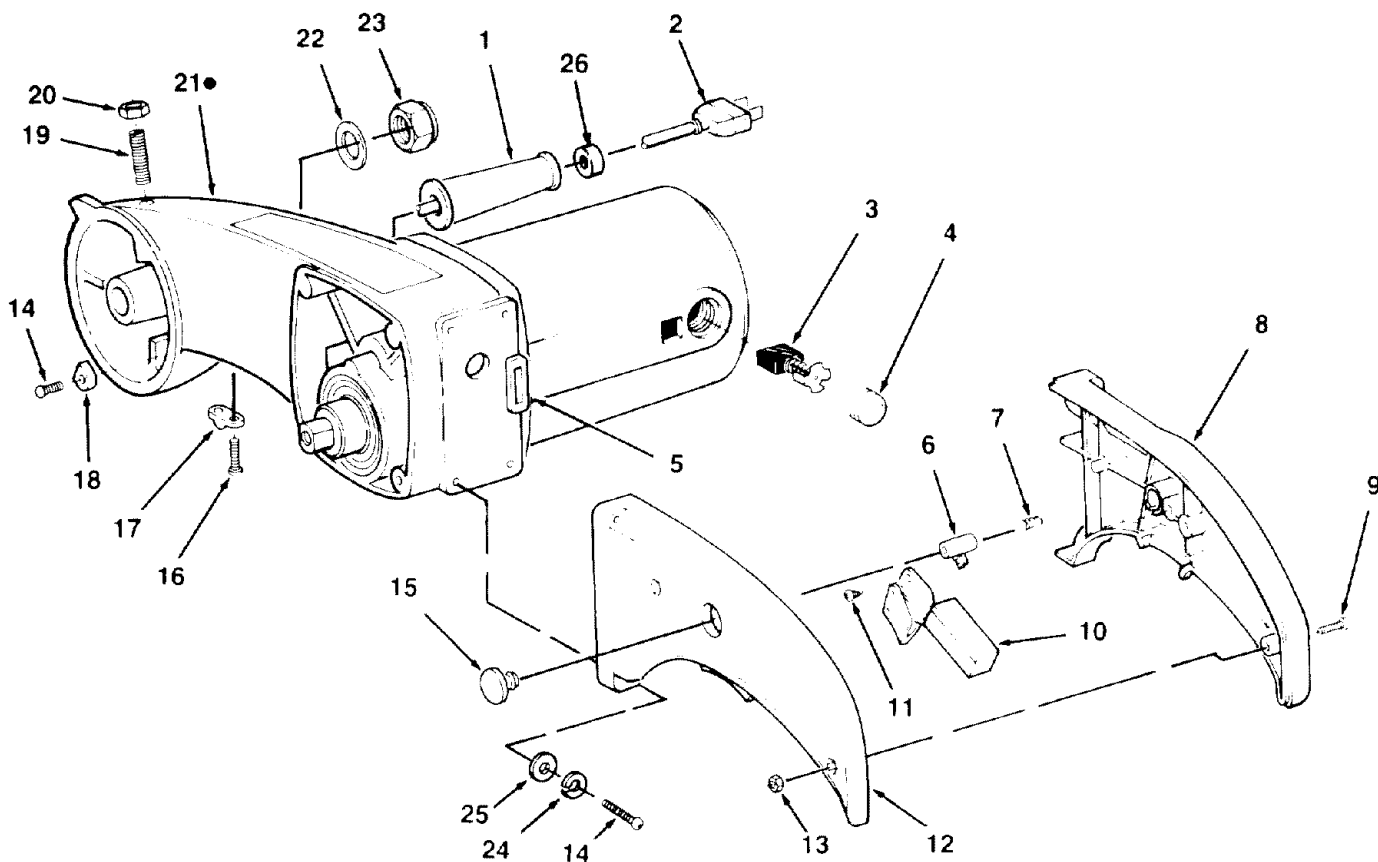

Always order by Part Number – Not by Key Number  
**FIGURE 2 — ARM AND MOTOR ASSEMBLY**

**WARNING:** For your safety, this miter saw is specially insulated. To avoid electrical shock, fire or injury, use only parts identical to those identified in the parts list. Reassemble exactly as originally assembled.

Key No	Part No.	Description
1	821122	▲ • Guard-Cord
2	816704	▲ • Cord w/Plug
3	816768	▲ Brush
4	816770	▲ Cover-Brush
5	816740	Protector-Wire
6	816697	▲ Lock-Switch
7	816696	▲ † Spring-Switch Lock
8	818964	Handle-R.H.
9	816743-1	Screw Pan Hd M4 x 0.7-20
10	816700	▲ • Switch
11	817143	Screw Pan Hd TY "AB" M4 x 0.7-15
12	818965	Handle-L.H.
13	STD840407	* Nut Hex M4 x 0.7
14	816755	Screw Pan Hd M5 x 0.8-20
15	816701	Button-Switch

Key No	Part No.	Description
16	816743	Screw Pan HD M4 x 0.7-15
17	816725	Clamp-Cord
18	816668	Cushion
19	816698	▲ Screw-Set Slotted M10 x 1.5
20	STD841015	* Nut Hex M10 x 1.5
21	816689-1	▲ • Motor & Arm Asm. (Includes Keys 1, 2, 3, 4, 5, 16, 17)
22	60047	▲ Washer .630 x 1 x 1/32
23	816723	▲ Nut Lock M16
24	STD551110	* Lockwasher #10
25	818043	Washer .350 x .170 x .03
26	821121	Bushing
—	SP5404	Owner's Manual (Not Illustrated)

• **WARNING:** Any Attempt To Repair Or Replace Electrical Parts On This Unit May Create A HAZARD Unless Repair Is Done By A Qualified Service Technician. Repair Service Is Available At Your Nearest Sears Store.

\* Standard Hardware Item—May Be Purchased Locally.

† See Mechanical Assembly Caution on page 31.

▲ **WARNING:** These Items Are Important To The Safety Of This Tool. Do Not Substitute Common Parts.

# repair parts

## PARTS LIST FOR CRAFTSMAN 10" COMPOUND MITER SAW MODEL NO. 113.234600

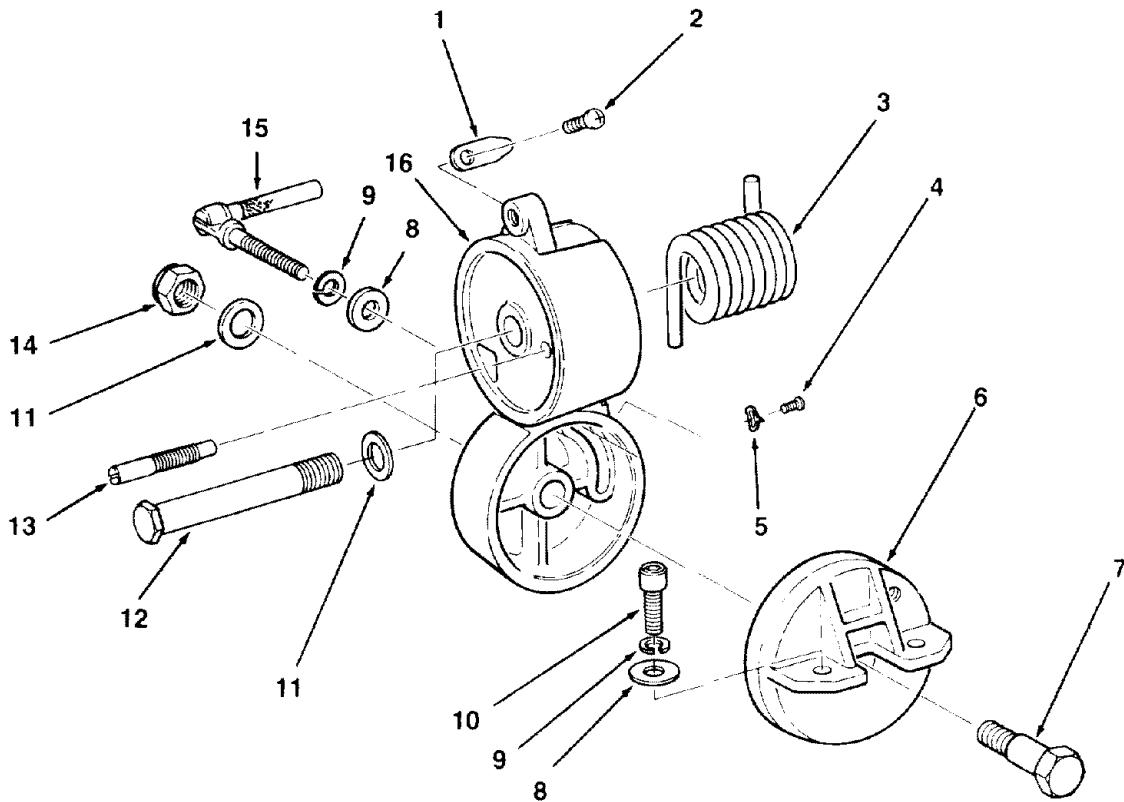

Always order by Part Number—Not by Key Number

**FIGURE 3—PIVOT ASSEMBLY**

Key No.	Part No.	Description
1	816664	Plate-Lock
2	816674	Screw Pan HD. Shoulder M6
3	816671	⚠ ‡ Spring-Torsion
4	STD510602	* Screw Pan HD. 6-32 x 1/4
5	816686	Indicator-Bevel
6	507815	Pivot-Support
7	816722	⚠ Bolt-Bevel
8	817182	Washer 10 x 19 x 1.8

Key No.	Part No.	Description
9	STD551137	* Lockwasher 3/8
10	141594-44	Screw Soc HD. Cap 3/8-16 x 1-1/2
11	60047	Washer .630 x 1 x 1/32
12	816721	⚠ Bolt-Pivot
13	816666	Bolt-Stop
14	816723	⚠ Nut Lock M16
15	816863-2	Clamp-Bolt
16	818071	Pivot

\*Standard Hardware Item—May Be Purchased Locally.

‡See Mechanical Assembly Caution on page 29.

**⚠ WARNING: These Items Are Important To The Safety Of This Tool. Do Not Substitute Common Parts.**

# repair parts

## PARTS LIST FOR CRAFTSMAN 10" COMPOUND MITER SAW MODEL NO. 113.234600

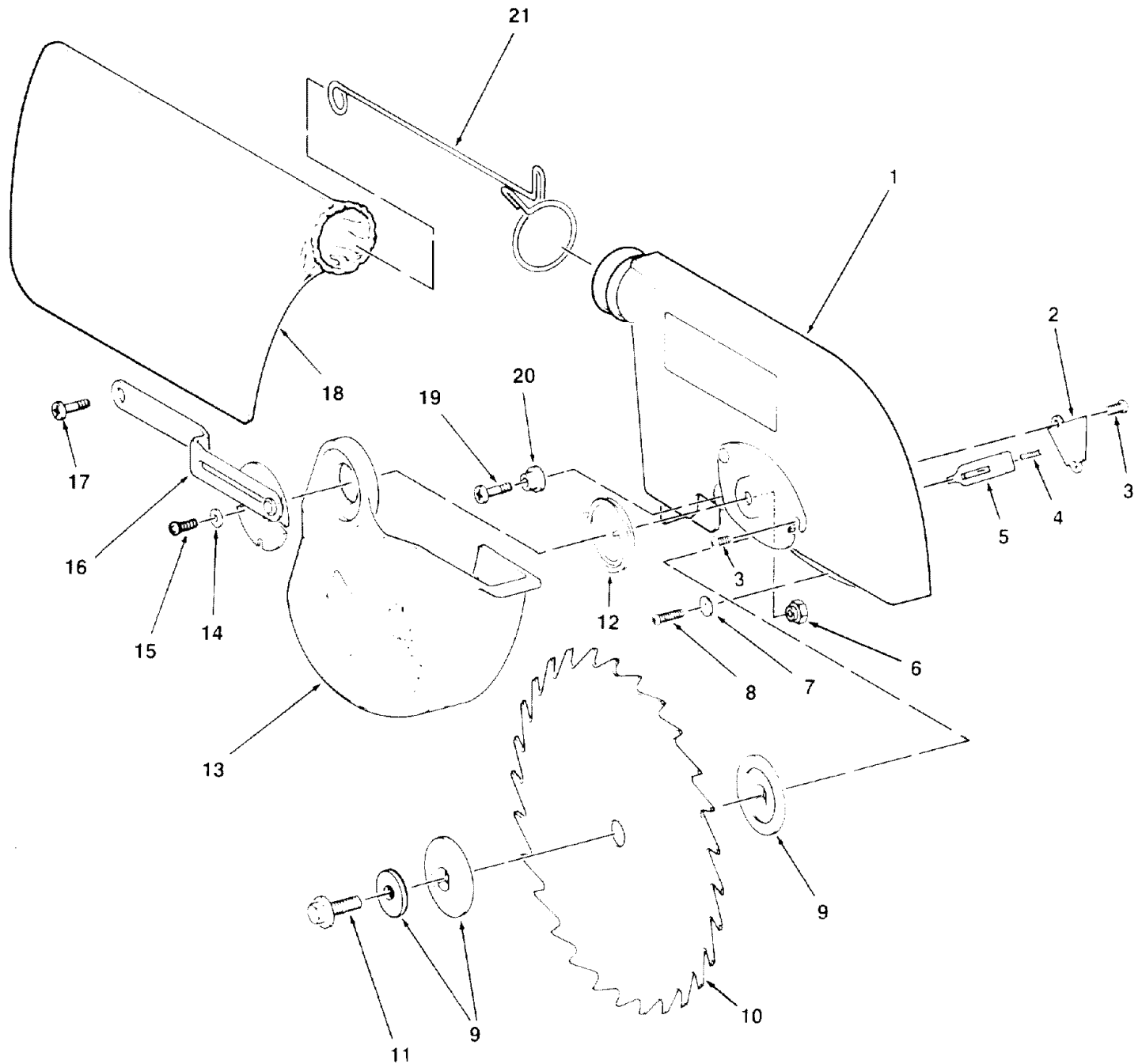

# repair parts

## PARTS LIST FOR CRAFTSMAN 10" COMPOUND MITER SAW MODEL NO. 113.234600

Always order by Part Number—Not by Key Number

**FIGURE 4. Blade & Blade Guard Asm.‡**

Key No.	Part No.	Description	Key No.	Part No.	Description
1	507758	Guard Asm.	12	816677	‡ Spring-Guard
2	816706	Plate-Retainer	13	816711	‡ Guard-Lower
3	STD511103	* Screw Pan HD. 10-32 x 3/8	14	60041	⚠ * Washer 13/64 x 7/16 x 1/32
4	816708	Spring	15	816333-1	⚠ * Screw Pan HD. TY "TT" 10-32 x 1/2
5	816707	Lock-Spindle	16	507757	Lever Asm.-Actuator
6	818962	⚠ Bushing Hex	17	817144	Screw-Shoulder 1/4-20 x 1/2
7	STD852005	⚠ * Lockwasher 5mm	18	816811	Bag-Dust
8	816755-2	⚠ Screw Pan HD. M5 x 15	19	817145	Screw-Shoulder 10-32 x 7/8
9	507759	⚠ Collar-Blade Set (Includes Key #13)	20	816818	Sleeve-Rubber
10	9-32668	† 10-in. Chisel Tooth Saw Blade	21	816812	Clamp-Bag
11	816703	⚠ Scr. Hex Washer HD. L.H. M8 x 1.25			

\*Standard Hardware Item—May Be Purchased Locally.

‡See following Mechanical Assembly Caution.

† Stock Item May Be Secured Through The Hardware Department Of Most Sears Retail Or Catalog Order Houses.

**⚠ WARNING: These Items Are Important To The Safety Of This Tool. Do Not Substitute Common Parts.**

**CAUTION: Mechanical assembly, to qualified service technician.**

1. Wear approved eye protection when working with coil springs including spring, switch lock 816696.
2. Incorrect re-assembly of torsion spring 816671 can cause an unsafe condition because cutting head fails to rise fully to stop, or because spring fails through over-stress.
3. Improper re-assembly of mechanisms controlling movement of lower guard 816711 can cause an unsafe condition because guard fails to operate freely as cutting head is moved up and down; or because, with cutting head up, manually rotated guard is not (lightly) restored to the closed position by guard spring 816677.

## CARBIDE TIPPED BLADES

### SAFETY INSTRUCTIONS & WARNINGS

OSHA required industrial users to inspect tool prior to mounting for cracks, chipped or bent teeth, or cutting edges that are not sharp. The tool must be completely clean to allow proper inspection.

See CFR § 1910.213

WOODWORKING MACHINERY REQUIREMENTS-ITEM S-7

“All cracked saws shall be removed from service.”

Do not operate saw machine without proper saw blade guard in place. Other important instructions and warnings regarding your safety are contained in saw machine owner's manual. If you do not have such a manual, contact the machine manufacturer to obtain one before using the saw machine with this blade.

Carbide is a very hard but brittle material. Care should be taken while mounting, using and storing carbide blades to prevent accidental damage. Slight shocks, such as striking tip during handling, can seriously damage the blade. Foreign objects in the workpiece, such as wire or nails, can also cause tips to crack or break off.

Never use blade on saw machine that will exceed maximum recommended blade R.P.M.

Always wear proper eye protection which complies with current ANSI Standard Z87.1 when using any power tool.

Before using, Always:

- Visually examine blade and tips for cracks breakage, missing or loose tips, or other damage. **DO NOT USE IF DAMAGE IS SUSPECTED.**
- Mount blade securely in proper rotation direction.
- Never leave a running machine unattended.

**FAILURE TO HEED THESE INSTRUCTIONS AND WARNINGS REGARDING USE OF THIS PRODUCT CAN RESULT IN SERIOUS BODILY INJURY.**



**SEARS**

**owner's  
manual**

**SERVICE**

**MODEL NO.  
113.234600**

**10" COMPOUND  
MITER SAW**

**HOW TO ORDER  
REPAIR PARTS**

## **10-INCH COMPOUND MITER SAW**

Now that you have purchased your 10-inch Compound Miter Saw, should a need ever exist for repair parts or service, simply contact any Sears Service Center and most Sears, Roebuck and Co. stores. Be sure to provide all pertinent facts when you call or visit.

The model number of your 10-inch Compound Miter Saw will be found on a plate attachment to your saw, at the side of the Miter Saw arm.

WHEN ORDERING REPAIR PARTS, ALWAYS GIVE THE FOLLOWING INFORMATION:

<b>PART NUMBER</b>	<b>PART DESCRIPTION</b>
<b>MODEL NUMBER</b> 113.234600	<b>NAME OF ITEM</b> 10" COMPOUND MITER SAW

All parts listed may be ordered from any Sears Service Center and most Sears stores. If the parts you need are not stocked locally, your order will be electronically transmitted to a Sears Repair Parts Distribution Center for handling.

**Sold by SEARS, ROEBUCK AND CO., Chicago, IL 60684 U.S.A.**