

**SEARS**

# **CRAFTSMAN<sup>®</sup>**

**MODEL NUMBER 917.258670 OWNER'S MANUAL**

**EZ<sup>3</sup>**

- Assembly
- Operation
- Customer Responsibilities
- Service and Adjustments
- Repair Parts

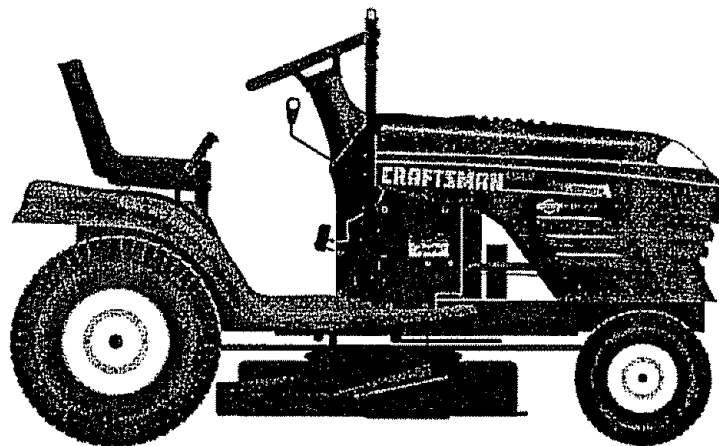

**CAUTION: Read and follow all safety rules and instructions before operating this equipment.**  
FOR CONSUMER ASSISTANCE HOT LINE, CALL THIS TOLL FREE NUMBER: 1-800-659-5917

**Sears, Roebuck and Co., Hoffman Estates, IL 60179 U.S.A.**



# SAFETY RULES



## Safe Operation Practices for Ride-On Mowers

**IMPORTANT: THIS CUTTING MACHINE IS CAPABLE OF AMPUTATING HANDS AND FEET AND THROWING OBJECTS. FAILURE TO OBSERVE THE FOLLOWING SAFETY INSTRUCTIONS COULD RESULT IN SERIOUS INJURY OR DEATH.**

### I. GENERAL OPERATION

- Read, understand, and follow all instructions in the manual and on the machine before starting.
- Only allow responsible adults, who are familiar with the instructions, to operate the machine.
- Clear the area of objects such as rocks, toys, wire, etc., which could be picked up and thrown by the blade.
- Be sure the area is clear of other people before mowing. Stop machine if anyone enters the area.
- Never carry passengers.
- Do not mow in reverse unless absolutely necessary. Always look down and behind before and while backing.
- Be aware of the mower discharge direction and do not point it at anyone. Do not operate the mower without either the entire grass catcher or the guard in place.
- Slow down before turning.
- Never leave a running machine unattended. Always turn off blades, set parking brake, stop engine, and remove keys before dismounting.
- Turn off blades when not mowing.
- Stop engine before removing grass catcher or unclogging chute.
- Mow only in daylight or good artificial light.
- Do not operate the machine while under the influence of alcohol or drugs.
- Watch for traffic when operating near or crossing roadways.
- Use extra care when loading or unloading the machine into a trailer or truck.

### II. SLOPE OPERATION

Slopes are a major factor related to loss-of-control and tipover accidents, which can result in severe injury or death. All slopes require extra caution. If you cannot back up the slope or if you feel uneasy on it, do not mow it.

#### DO:

- Mow up and down slopes, not across.
- Remove obstacles such as rocks, tree limbs, etc.
- Watch for holes, ruts, or bumps. Uneven terrain could overturn the machine. *Tall grass can hide obstacles.*
- Use slow speed. Choose a low gear so that you will not have to stop or shift while on the slope.
- Follow the manufacturer's recommendations for wheel weights or counterweights to improve stability.
- Use extra care with grass catchers or other attachments. These can change the stability of the machine.
- Keep all movement on the slopes *slow and gradual*. Do not make sudden changes in speed or direction.
- Avoid starting or stopping on a slope. If tires lose traction, disengage the blades and proceed slowly *straight* down the slope.

#### DO NOT:

- *Do not* turn on slopes unless necessary, and then, turn slowly and gradually downhill, if possible.
- *Do not* mow near drop-offs, ditches, or embankments. The mower could suddenly turn over if a wheel is over the edge of a cliff or ditch, or if an edge caves in.
- *Do not* mow on wet grass. Reduced traction could cause sliding.
- *Do not* try to stabilize the machine by putting your foot on the ground.
- *Do not* use grass catcher on steep slopes.

### III. CHILDREN

Tragic accidents can occur if the operator is not alert to the presence of children. Children are often attracted to the machine and the mowing activity. *Never* assume that children will remain where you last saw them.

- Keep children out of the mowing area and under the watchful care of another responsible adult.
- Be alert and turn machine off if children enter the area.
- Before and when backing, look behind and *down* for small children.
- Never carry children. They may fall off and be seriously injured or interfere with safe machine operation.
- Never allow children to operate the machine.
- Use extra care when approaching blind corners, shrubs, trees, or other objects that may obscure vision.

### IV. SERVICE

- Use extra care in handling gasoline and other fuels. They are flammable and vapors are explosive.
  - Use only an approved container.
  - Never remove gas cap or add fuel with the engine running. Allow engine to cool before refueling. Do not smoke.
  - Never refuel the machine indoors.
  - Never store the machine or fuel container inside where there is an open flame, such as a water heater.
- Never run a machine inside a closed area.
- Keep nuts and bolts, especially blade attachment bolts, tight and keep equipment in good condition.
- Never tamper with safety devices. Check their proper operation regularly.
- Keep machine free of grass, leaves, or other debris build-up. Clean oil or fuel spillage. Allow machine to cool before storing.
- Stop and inspect the equipment if you strike an object. Repair, if necessary, before restarting.
- Never make adjustments or repairs with the engine running.
- Grass catcher components are subject to wear, damage, and deterioration, which could expose moving parts or allow objects to be thrown. Frequently check components and replace with manufacturer's recommended parts, when necessary.
- Mower blades are sharp and can cut. Wrap the blade(s) or wear gloves, and use extra caution when servicing them.
- Check brake operation frequently. Adjust and service as required.



Look for this symbol to point out important safety precautions. It means **CAUTION!!! BECOME ALERT!!! YOUR SAFETY IS INVOLVED.**



**CAUTION:** Always disconnect spark plug wire and place wire where it cannot contact spark plug in order to prevent accidental starting when setting up, transporting, adjusting or making repairs.

## WARNING

The engine exhaust from this product contains chemicals known to the State of California to cause cancer, birth defects, or other reproductive harm.

**CONGRATULATIONS** on your purchase of a Sears Tractor. It has been designed, engineered and manufactured to give you the best possible dependability and performance.

Should you experience any problem you cannot easily remedy, please contact your nearest Sears Authorized Service Center/Department. We have competent, well-trained technicians and the proper tools to service or repair this tractor.

Please read and retain this manual. The instructions will enable you to assemble and maintain your tractor properly. Always observe the "SAFETY RULES".

MODEL NUMBER	917.258670
SERIAL NUMBER	_____
DATE OF PURCHASE	_____
THE MODEL AND SERIAL NUMBERS WILL BE FOUND ON A PLATE UNDER THE SEAT.	
YOU SHOULD RECORD BOTH SERIAL NUMBER AND DATE OF PURCHASE AND KEEP IN A SAFE PLACE FOR FUTURE REFERENCE.	

### MAINTENANCE AGREEMENT

A Sears Maintenance Agreement is available on this product. Contact your nearest Sears store for details.

### CUSTOMER RESPONSIBILITIES

- Read and observe the safety rules.
- Follow a regular schedule in maintaining, caring for and using your tractor.
- Follow the instructions under "Customer Responsibilities" and "Storage" sections of this owner's manual.

**WARNING:** This tractor is equipped with an internal combustion engine and should not be used on or near any unimproved forest-covered, brush-covered or grass-cov-

### PRODUCT SPECIFICATIONS

HORSEPOWER:	19.5
GASOLINE CAPACITY AND TYPE:	3.5 GALLONS UNLEADED REGULAR
OIL TYPE (API-SF/SG):	SAE 30 (above 32°F) SAE 5W-30 (below 32°F)
OIL CAPACITY:	3.0 PINTS
SPARK PLUG: (GAP: .030")	CHAMPION RJ19LM
VALVE CLEARANCE:	INTAKE: .004" - .006" EXHAUST: .007" - .009"
GROUND SPEED (MPH):	FORWARD: 0 - 5.5 REVERSE: 0 - 2.4
TIRE PRESSURE:	FRONT: 14 PSI REAR: 10 PSI
CHARGING SYSTEM:	3 AMPS BATTERY 5 AMPS HEADLIGHTS
BATTERY:	AMP/HR: 30 MIN. CCA: 240 CASE SIZE: U1R
BLADE BOLT TORQUE:	30-35 FT. LBS.

ered land unless the engine's exhaust system is equipped with a spark arrester meeting applicable local or state laws (if any). If a spark arrester is used, it should be maintained in effective working order by the operator.

In the state of California the above is required by law (Section 4442 of the California Public Resources Code). Other states may have similar laws. Federal laws apply on federal lands. A spark arrester for the muffler is available through your nearest Sears Authorized Service Center/Department (See REPAIR PARTS section of this manual).

### LIMITED TWO YEAR WARRANTY ON CRAFTSMAN RIDING EQUIPMENT

For two (2) years from the date of purchase, if this Craftsman Riding Equipment is maintained, lubricated and tuned up according to the instructions in the owner's manual, Sears will repair or replace, free of charge, any parts found to be defective in material or workmanship.

This Warranty does not cover:

- Expendable items which become worn during normal use, such as blades, spark plugs, air cleaners, belts, etc.
- Tire replacement or repair caused by punctures from outside objects, such as nails, thorns, stumps, or glass.
- Repairs necessary because of operator abuse, negligence, improper storage or accident or the failure to maintain the equipment according to the instructions contained in the owner's manual.
- Riding equipment used for commercial or rental purposes.

### LIMITED 90 DAY WARRANTY ON BATTERY

For ninety (90) days from date of purchase, if any battery included with this riding equipment proves defective in material or workmanship and our testing determines the battery will not hold a charge, Sears will replace the battery at no charge.

IN-HOME WARRANTY SERVICE ON YOUR CRAFTSMAN RIDING EQUIPMENT IS AVAILABLE AT NO-CHARGE FOR 30 DAYS FROM THE DATE OF PURCHASE. PLEASE CONTACT YOUR NEAREST SERVICE CENTER. AFTER 30 DAYS FROM THE DATE OF PURCHASE, WARRANTY SERVICE IS AVAILABLE BY TAKING YOUR CRAFTSMAN RIDING EQUIPMENT TO YOUR NEAREST SEARS SERVICE CENTER. (IN-HOME WARRANTY SERVICE WILL STILL BE AVAILABLE AFTER 30 DAYS FROM THE DATE OF PURCHASE BUT A STANDARD TRIP CHARGE WILL APPLY.) THIS WARRANTY APPLIES ONLY WHILE THIS PRODUCT IS IN THE UNITED STATES.

This Warranty gives you specific legal rights, and you may also have other rights which may vary from state to state.

SEARS, ROEBUCK AND CO., D/817 WA, HOFFMAN ESTATES, IL 60179

# TABLE OF CONTENTS







SAFETY RULES .....	2	OPERATION .....	11-16
PRODUCT SPECIFICATIONS .....	3	MAINTENANCE SCHEDULE .....	17
CUSTOMER RESPONSIBILITIES .....	3, 17-20	SERVICE AND ADJUSTMENTS .....	21-27
WARRANTY .....	3	STORAGE .....	28
TABLE OF CONTENTS .....	4	TROUBLESHOOTING .....	29-30
INDEX .....	4	REPAIR PARTS - TRACTOR .....	32-47
TRACTOR ACCESSORIES .....	5	REPAIR PARTS - ENGINE .....	48-53
ASSEMBLY .....	7-10	PARTS ORDERING/SERVICE .....	BACK PAGE

## INDEX

<b>A</b>		<b>E</b>		<b>O</b>	
Accessories .....	5	Electrical:		Oil:	
Adjustments:		Interlocks and Relays .....	26	Cold Weather Conditions .....	14,19
Brake .....	24	Schematic .....	31	Engine .....	19
Carburetor .....	27	Wiring Diagram .....	32	Storage .....	28
Mower:		Engine:		Operation .....	11-16
Front-To-Back .....	22	Air Filter .....	19	Operating Mower .....	14
Side-To-Side .....	22	Air Screen .....	19	Options:	
Throttle Control Cable .....	26-27	Cooling Fins, Engine .....	20	Accessories .....	5
Air Filter, Engine .....	19	Oil Change .....	19	Spark Arrester .....	3,40
Air Screen, Engine .....	19	Oil Level .....	14,19	<b>P</b>	
Assembly .....	7-10	Oil Type .....	19	Parking Brake .....	12-13
<b>B</b>		Preparation .....	14	Parts Bag .....	6
Battery:		Repair Parts .....	48-53	Parts, Replacement/Repair .....	32-47
Charging .....	18	Starting .....	14	Product Specifications .....	3
Cleaning .....	18	Storage .....	28	<b>R</b>	
Starting with Weak Battery .....	26	<b>F</b>		Repair Parts .....	32-47
Storage .....	28	Filters:		<b>S</b>	
Terminals .....	18	Air .....	19	Safety Rules .....	2
Belts:		Fuel .....	20	Seal .....	8
Motion Drive		Fuel:		Service and Adjustments .....	21-27
Removal/Replacement .....	24	Type .....	14	Brake .....	24
Mower Drive		Storage .....	28	Carburetor .....	27
Removal/Replacement .....	23	Fuse .....	26	Fuse .....	26
Mower Blade Drive		<b>G</b>		Hood Removal/Installation .....	28
Removal/Replacement .....	23	Gauge Wheels .....	9,14	Motion Drive Belt	
Blade:		<b>H</b>		Removal/Replacement .....	24
Sharpening .....	18	Hood Removal/Installation .....	26	Mower Drive	
Replacement .....	18	<b>L</b>		Removal/Replacement .....	23
Brake Adjustment .....	24	Leveling Mower Deck .....	21-22	Mower Blade Drive Belt	
<b>C</b>		Lubrication Chart .....	17	Removal/Replacement .....	23
Carburetor Adjustment .....	27	<b>M</b>		Mower Adjustment:	
Controls, Tractor .....	13	Maintenance Schedule .....	17	Front-to-Back .....	22
Customer Responsibilities .....	3,17-20	Mower:		Side-to-Side .....	22
Engine:		Adjustment, Front-to-Back .....	22	Mower Installation .....	21
Air Filter .....	19	Adjustment, Side-to-Side .....	22	Mower Removal .....	21
Air Screen, Engine .....	19	Blade Sharpening .....	18	Tire Care .....	8,18,25
Battery .....	18	Blade Replacement .....	18	Slope Guide Sheet .....	55
Cooling Fins, Engine .....	19	Cutting Height .....	13	Spark Plugs .....	20
Engine Oil .....	20	Installation .....	9,21	Specifications .....	3
Fuel Filler .....	20	Operation .....	11-16	Starting the Engine .....	14-15
Spark Plugs .....	18	Removal .....	21	Steering Wheel .....	7,25
Tractor:		Mowing Tips .....	16	Stopping the Tractor .....	13
Blades .....	18	Muffler .....	20	Storage .....	28
Lubrication Chart .....	17	Spark Arrester .....	3,40	<b>T</b>	
Maintenance Schedule .....	17	Mulcher Plate .....	10	Throttle Control Cable Adjustment .....	26
Tire Care .....	8,18,25	<b>M</b>		Tires .....	8,18,25
Cutting Height, Mower .....	13	<b>O</b>		Trouble Shooting Chart .....	29-30

# ACCESSORIES AND ATTACHMENTS

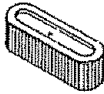
These accessories and attachments were available through most Sears retail outlets and service centers when the tractor was purchased. Most Sears stores can order these items for you when you provide the model number of your tractor.

ENGINE					MAINTENANCE	
SPARK PLUG	GAS CAN	ENGINE OIL	FUEL STABILIZER	AIR FILTER	BLADES	BELTS
						

## PERFORMANCE

Sears offers a wide variety of attachments that fit your tractor. Many of these are listed below with brief explanations of how they can help you. This list was current at the time of publication; however, it may change in future years - more attachments may be added, changes may be made in these attachments, or some may no longer be available or fit your model. Contact your nearest Sears store for the accessories and attachments that are available for your tractor.

Most of these attachments do not require additional hitches or conversion kits (those that do are indicated) and are designed for easy attaching and detaching.

**AERATOR** promotes deep root growth for a healthy lawn. Tapered 2.5-inch steel spikes mounted on 10-inch diameter discs puncture holes in soil at close intervals to let moisture soak in. Steel weight tray for increased penetration.

**BAGGER** lets you collect grass clippings and leaves for a healthier, neater looking lawn. Two Permanex containers hold 30-gallon plastic bags.

**BUMPER** protects front end of tractor from damage.

**CARTS** make hauling easy. Variety of sizes available, plus accessories such as side panel kits, tool caddy, cart cover, protective mat and dolly.

**CORING AERATOR** takes small plugs out of soil to allow moisture and nutrients to reach grass roots. 36-inch swath. 24 hardened steel coring tips. 150 lb. capacity weight tray.

**EASY OIL DRAIN VALVE** makes oil changes easier, faster.

**FRONT NOSE ROLLER** canters in front of mower deck to reduce chances of "scalping" on uneven terrain.

**GANG HITCH** lets you tow 2 or 3 pull-behind attachments at once, such as sweepers, dethatchers, aerators (not for use with rollers, carts or other heavy attachments).

**GAUGE WHEELS** on both sides of the mower deck reduce chances of "scalping" on uneven terrain. For mower decks not so equipped.

**MULCH RAKE/DETHATCHER** loosens soil and flips thatch and matted leaves to lawn surface for easy pickup. Twenty spring line teeth. Useful to prepare bare areas for seeding. Available for front or rear mounting. **HIGH PERFORMANCE REEL-ACTION SPRING TINE DETHATCHER** covers 36-inch wide path and tosses thatch into large hopper. Mounts behind tractor.

**MULCHING CLOSE-OUT PLATE KIT**, once installed, lets you mulch, discharge or bag clippings (bagger optional) without changing blades. For models not equipped as 3-in-1 Convertible mowers. See "MOWER" in the Repair Parts section of this manual.

**RAMP TOPS AND FEET** let you load and unload tractor from a pickup truck. Use with 2 x 8 or 2 x 10 lumber.

**ROLLER** for smoother lawn surface. 36-inch wide, 18-inch diameter water-tight drum holds up to 390 lbs. of weight. Rounded edges prevent harm to turf. Adjustable scraper automatically cleans drum.

**SNOW BLADE** for snow removal only. 14-inch high, 48-inch wide blade clears 42-inch path when angled left or right. Raises, lowers with side lever. Adjustable skids; replaceable, reversible scraper bar. (Use with tire chains and wheel weights and/or rear drawbar weight.)

**SNOWTHROWER** has 40-inch swath. Drum-type auger handles powdery and wet/heavy snow. Mounts easily with simple pin arrangement. Discharge chute adjusts from tractor seat. 6-inch diameter spout discharges snow 10 to 50 feet. Lift controlled at tractor seat. (Use with chains and wheel weights and/or rear drawbar weight.)

**SPRAYERS** use 12-volt DC electric motor that connects to the tractor battery or other 12-volt source. Includes booms for automatic spraying and hand held wand for spot spraying. Wand has adjustable spray pattern. For applying herbicides, insecticides, fungicides and liquid fertilizers.

**SPREADER/SEEDERS** make seeding, fertilizing, and weed killing easy. Broadcast spreaders are also useful for granular deicers and sand.

**SWEEPERS** let you collect grass clippings and leaves.

**TILLER** has 5 hp engine and 36-inch swath to prepare seed beds, cultivate and compost garden residue. Tiller has its own built-in lift and depth control system and does NOT require a sleeve hitch. Fits any lawn, yard or garden tractor. Simply hook up to the tractor drawbar and go! **Optional accessories** convert unit for dethatching, aerating, hilling, without tools.

**TIRE CHAINS** are heavy duty; closely spaced extra-large cross links give smooth ride, outstanding traction.

**TRACTOR CAB** has heavy duty vinyl fabric over tubular steel frame, ABS plastic top; clear plastic windshield offers 360 degree visibility. Hinged metal doors with catch. Keeps operator warm and dry. Remove vinyl sides and windshields for use as sun protector in summer. **Optional accessories include:** tinted/tempered solid safety glass windshield with hand operated wiper; 12-volt amber caution light for mounting on cab top.

**VACS** for powerful collection of heavy grass clippings and leaves. **Optional wand attachment** to pick up debris in hard-to-reach places. **VAC/CHIPPER** includes a chipper-shredder.

**WEIGHT BRACKET** for drawbar for snow removal applications. Uses (1) 55 lb weight.

**WHEEL WEIGHTS** for rear wheels provide needed traction for snow removal or dozing heavy materials.

# CONTENTS OF HARDWARE PACK

## Parts Bag contents shown full size

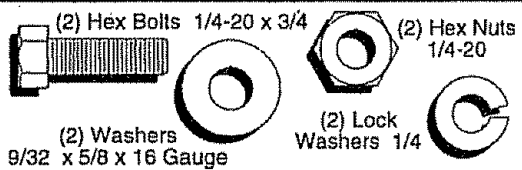
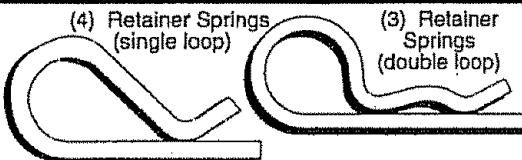
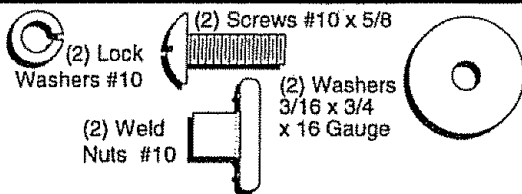
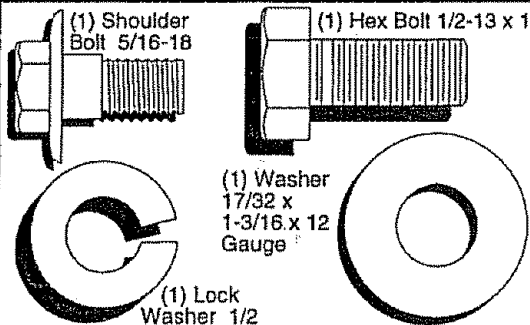
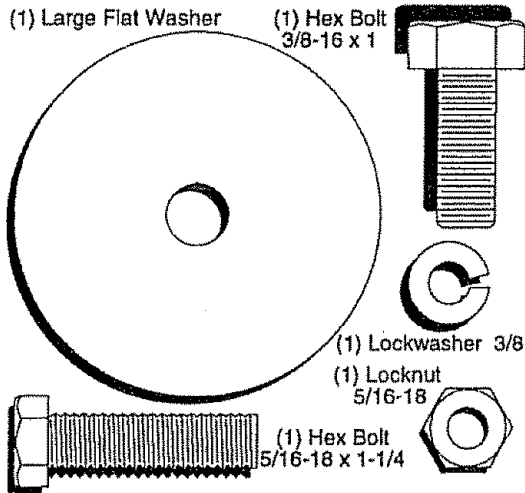

## Parts packed separately in carton

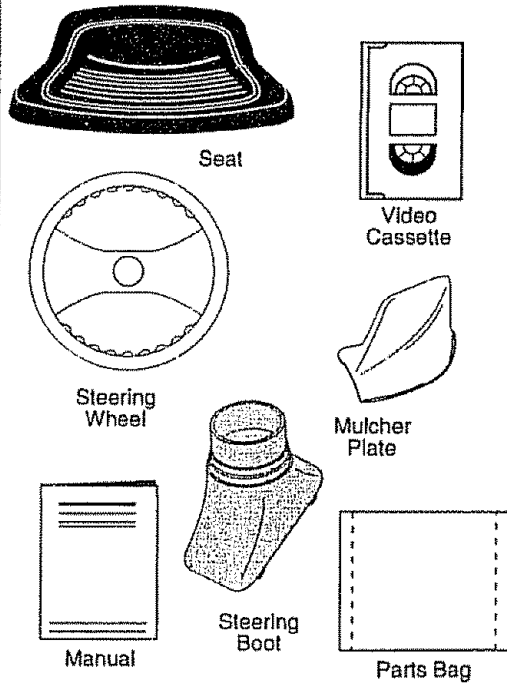

## Parts bag contents not shown full size

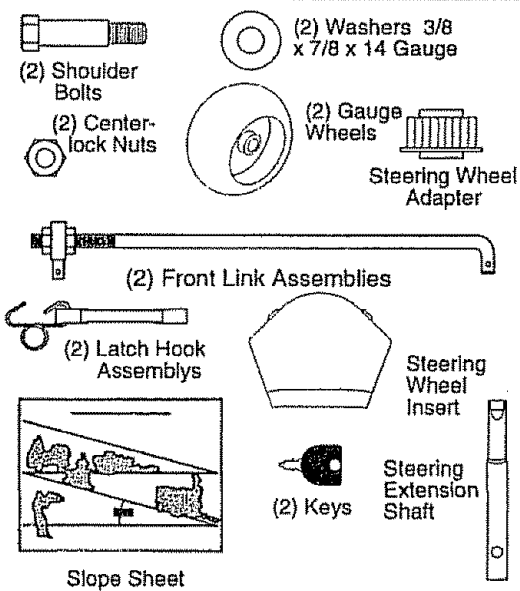

# ASSEMBLY

Your new tractor has been assembled at the factory with exception of those parts left unassembled for shipping purposes. To ensure safe and proper operation of your tractor all parts and hardware you assemble must be tightened securely. Use the correct tools as necessary to insure proper tightness.

## TOOLS REQUIRED FOR ASSEMBLY

A socket wrench set will make assembly easier. Standard wrench sizes are listed.

- |                    |                                 |
|--------------------|---------------------------------|
| (1) 9/16" wrench   | (1) 3/4" Socket w/drive ratchet |
| (2) 7/16" wrenches | Phillips Screwdriver            |
| (2) 1/2" wrench    | Tire pressure gauge             |
| (1) 3/4" wrench    | Utility knife                   |
|                    | Pliers                          |

When right or left hand is mentioned in this manual, it means when you are in the operating position (seated behind the steering wheel).

## TO REMOVE TRACTOR FROM CARTON UNPACK CARTON

- Remove all accessible loose parts and parts cartons from carton (See page 6).
- Cut, from top to bottom, along lines on all four corners of carton, and lay panels flat.
- Remove mower and package materials.
- Check for any additional loose parts or cartons and remove.

## BEFORE ROLLING TRACTOR OFF SKID

### ATTACH STEERING WHEEL (See Fig. 1)

#### ASSEMBLE EXTENSION SHAFT AND BOOT

- Slide extension shaft onto lower steering shaft. Align mounting holes in extension and lower shafts and install 5/16 hex bolt and locknut. Tighten securely.

**IMPORTANT: TIGHTEN BOLT AND NUT SECURELY TO 18-22 FT. LBS TORQUE**

- Place tabs of steering boot over tab slots in dash and push down to secure.

#### INSTALL STEERING WHEEL

- Position front wheels of the tractor so they are pointing straight forward.
- Slide steering wheel adapter onto steering shaft extension.
- Position steering wheel and sleeve assembly so cross bars are horizontal (left to right) and slide onto adapter.
- Assemble large flat washer, 3/8 lock washer, 3/8 hex bolt and tighten securely.
- Snap steering wheel insert into center of steering wheel.
- Remove protective plastic from tractor hood and grill.

**IMPORTANT: CHECK FOR AND REMOVE ANY STAPLES IN SKID THAT MAY PUNCTURE TIRES WHERE TRACTOR IS TO ROLL OFF SKID**

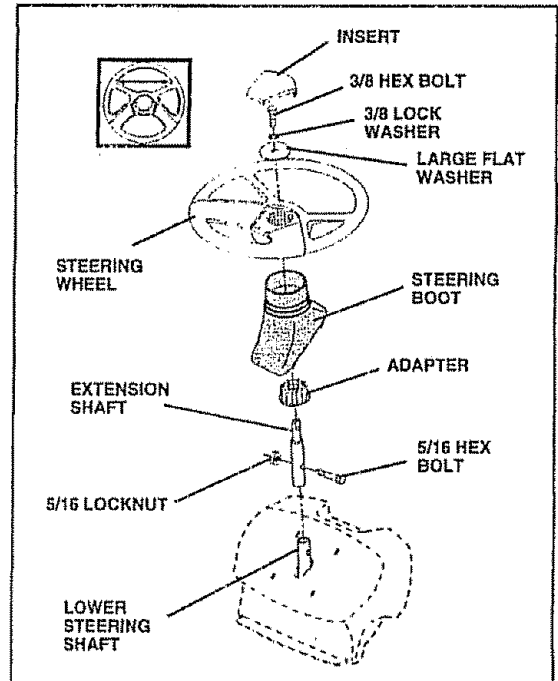

FIG. 1

## TO ROLL TRACTOR OFF SKID (See Operation section for location and function of controls)

- Press lift lever plunger and raise attachment lift lever to its highest position.
- Release parking brake by depressing clutch/brake pedal.
- Place freewheel control in freewheeling position to disengage transmission (See "TO TRANSPORT" in the Operation section of this manual).
- Roll tractor backwards off skid.
- Remove banding holding discharge guard up against tractor.

# ASSEMBLY

## HOW TO SET UP YOUR TRACTOR

### CONNECT BATTERY (See Fig. 2)



**CAUTION:** Do not short battery terminals. Before connecting battery, remove metal bracelets, wristwatch bands, rings, etc.

Positive terminal must be connected first to prevent sparking from accidental grounding.

- Lift hood to raised position.
- Open terminal access doors, remove terminal protective caps and discard.
- If this battery is put into service after month and year indicated on label (label located between terminals) charge battery for minimum of one hour at 6-10 amps.
- First connect RED battery cable to positive (+) battery terminal with hex bolt, flat washer, lock washer and hex nut as shown. Tighten securely.
- Connect BLACK grounding cable to negative (-) battery terminal with remaining hex bolt, flat washer, lock washer and hex nut. Tighten securely.
- Close terminal access doors

Use terminal access doors for:

- Inspection for secure connections (to tighten hardware).
- Inspection for corrosion.
- Testing battery.
- Jumping (if required).
- Periodic charging.

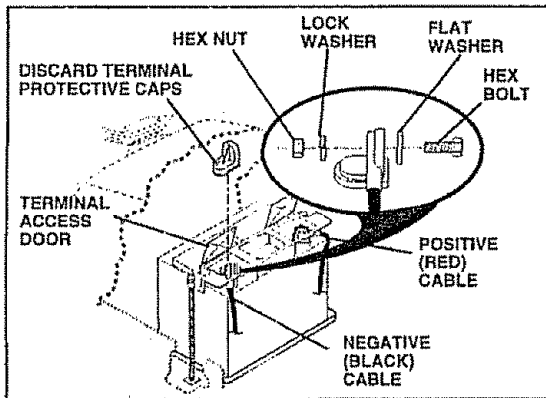

FIG. 2

### INSTALL SEAT (See Fig. 3)

Adjust seat before tightening adjustment bolt.

- Remove cardboard packing on seat pan.
- Place seat on seat pan and assemble shoulder bolt.
- Assemble adjustment bolt, lock washer and flat washer loosely. Do not tighten.
- Tighten shoulder bolt securely.
- Lower seat into operating position and sit on seat.
- Slide seat until a comfortable position is reached which allows you to press clutch/brake pedal all the way down.
- Get off seat without moving its adjusted position.
- Raise seat and tighten adjustment bolt securely.

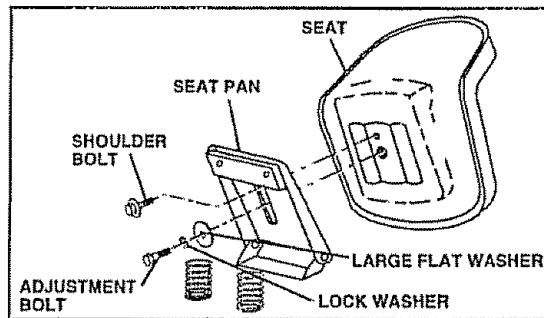

FIG. 3

### CHECK TIRE PRESSURE

The tires on your tractor were overinflated at the factory for shipping purposes. Correct tire pressure is important for best cutting performance.

- Reduce tire pressure to PSI shown in "PRODUCT SPECIFICATIONS" on page 3 of this manual.

### CHECK BRAKE SYSTEM

After you learn how to operate your tractor, check to see that the brake is properly adjusted. See "TO ADJUST BRAKE" in the Service and Adjustments section of this manual.

# ASSEMBLY

## INSTALL MOWER AND DRIVE BELT (See Figs. 4 and 7)

Be sure tractor is on level surface and mower suspension arms are raised with attachment lift control. Engage parking brake.

- Cut and remove ties securing anti-sway bar and belts. Swing anti-sway bar to left side of mower deck.
- Slide mower under tractor with discharge guard to right side of tractor.

**IMPORTANT: CHECK BELT FOR PROPER ROUTING IN ALL MOWER PULLEY GROOVES. INSTALL BELT INTO ENGINE PULLEY GROOVE.**

- Install one front link in top hole of the L.H. front mower bracket and L.H. front suspension bracket. Retain with two single loop retainer springs as shown.
- Install second front link in R.H. front suspension bracket and retain with single loop retainer spring as shown.
- Slide right side of mower back and install link in top hole of R.H. front mower bracket. Retain with single loop retainer spring as shown.
- Turn height adjustment knob counterclockwise until it stops.
- Lower mower linkage with attachment lift control.
- Place the suspension arms on outward pointing deck pins. If necessary, rock and raise front of mower to align deck pins with the holes in suspension arms. Retain with double loop retainer springs with loops down as shown.

- Connect anti-sway bar to chassis bracket under left footrest and retain with double loop retainer spring.
- Install clutch rod in clutch lever. Secure with retainer spring.
- Turn height adjustment knob clockwise to remove slack from mower suspension.
- Raise deck to highest position.
- Assemble gauge wheels as shown using long shoulder bolts, 3/8 washers, and 3/8-16 center locknuts. Tighten securely.
- Adjust gauge wheels before operating mower as shown in the Operation section of this manual.

## CHECK MOWER LEVELNESS

For best cutting results, mower should be properly leveled. See "TO LEVEL MOWER HOUSING" in the Service and Adjustments section of this manual.

## CHECK FOR PROPER POSITION OF ALL BELTS

See the figures that are shown for replacing motion, mower drive, and mower blade drive belts in the Service and Adjustments section of this manual. Verify that the belts are routed correctly.

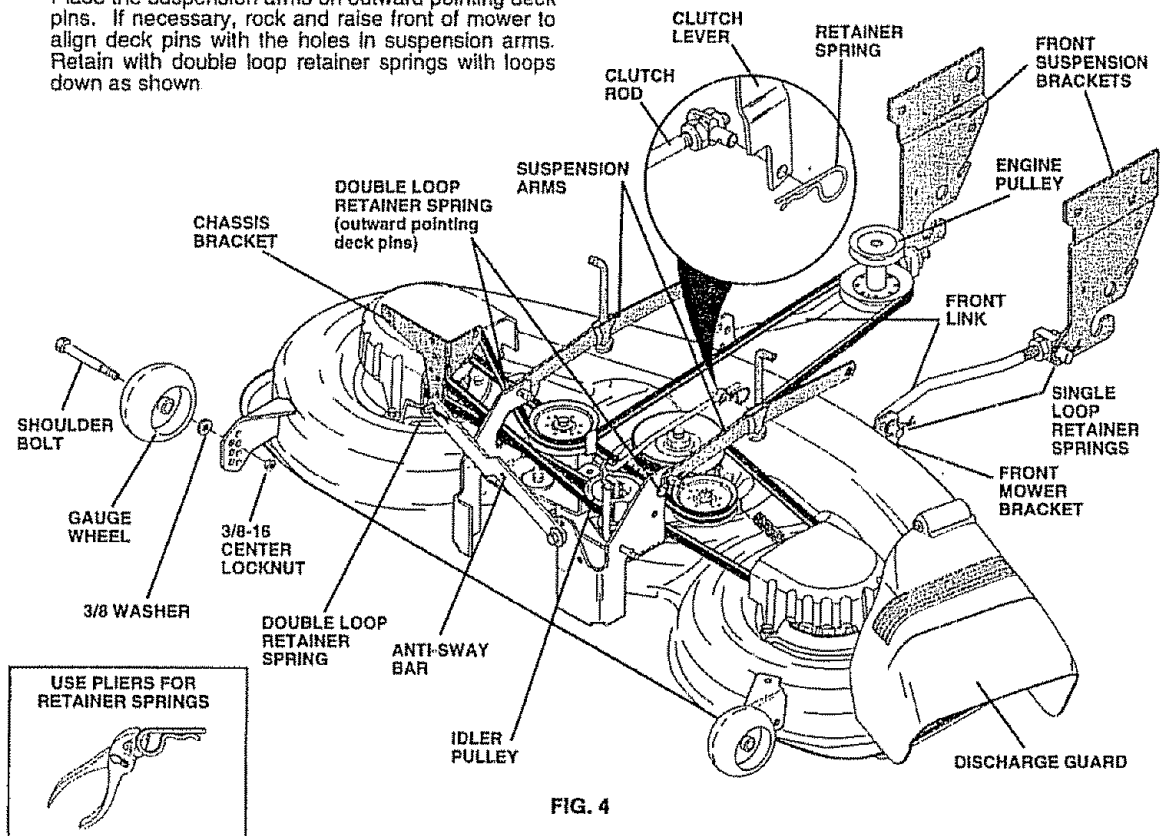

FIG. 4

# ASSEMBLY

## INSTALL MULCHER PLATE (See Figs. 5 and 6)

- Install two latch hooks to mulcher plate using screw, washer, lock washer, and weld nut as shown.

**NOTE:** Pre-assemble weld nut to latch hook by inserting weld nut from the top with hook pointing down.

- Tighten hardware securely.
- Raise and hold deflector shield in upright position.
- Place front of mulcher plate over front of mower deck opening and slide into place, as shown.
- Hook front latch into hole on front of mower deck.
- Hook rear latch into hole on back of mower deck.



**CAUTION:** Do not remove discharge guard from mower. Raise and hold guard when attaching mulcher plate and allow it to rest on plate while in operation.

## TO CONVERT TO BAGGING OR DISCHARGING

Simply remove mulcher plate and store in a safe place. Your mower is now ready for discharging or installation of optional grass catcher accessory.

**NOTE:** It is not necessary to change blades. The mulcher blades are designed for discharging and bagging also.

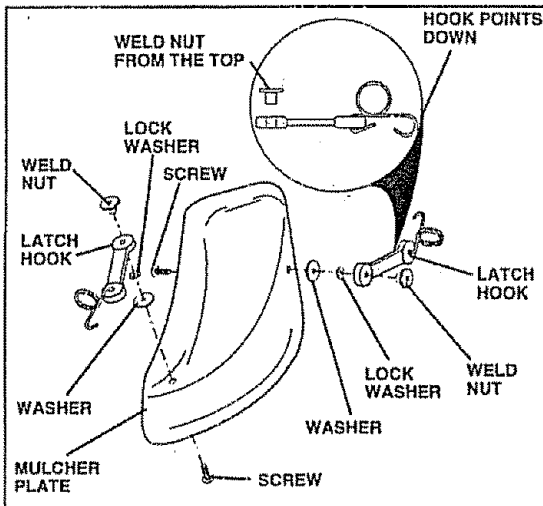

FIG. 5

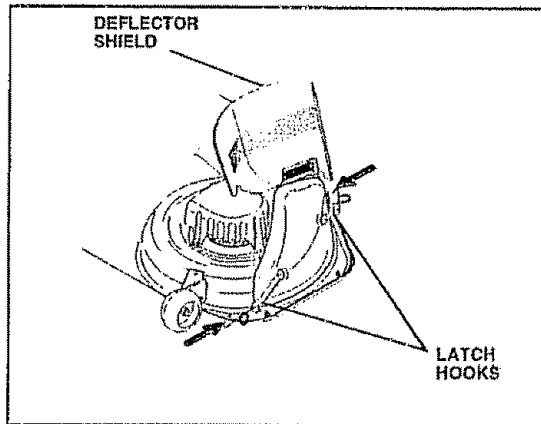

FIG. 6

## ✓CHECKLIST

*BEFORE YOU OPERATE AND ENJOY YOUR NEW TRACTOR, WE WISH TO ASSURE THAT YOU RECEIVE THE BEST PERFORMANCE AND SATISFACTION FROM THIS QUALITY PRODUCT.*

*PLEASE REVIEW THE FOLLOWING CHECKLIST:*

- ✓ All assembly instructions have been completed.
- ✓ No remaining loose parts in carton.
- ✓ Battery is properly prepared and charged. (Minimum 1 hour at 6 amps).
- ✓ Seat is adjusted comfortably and tightened securely.
- ✓ All tires are properly inflated. (For shipping purposes, the tires were overinflated at the factory).
- ✓ Be sure mower deck is properly leveled side-to-side/front-to-rear for best cutting results. (Tires must be properly inflated for leveling).
- ✓ Check mower and drive belts. Be sure they are routed properly around pulleys and inside all belt keepers.
- ✓ Check wiring. See that all connections are still secure and wires are properly clamped.
- ✓ Before driving tractor, be sure freewheel control is in drive position.

*WHILE LEARNING HOW TO USE YOUR TRACTOR, PAY EXTRA ATTENTION TO THE FOLLOWING IMPORTANT ITEMS:*

- ✓ Engine oil is at proper level.
- ✓ Fuel tank is filled with fresh, clean, regular unleaded gasoline.
- ✓ Become familiar with all controls - their location and function. Operate them before you start the engine.
- ✓ Be sure brake system is in safe operating condition.
- ✓ It is important to purge the transmission before operating your tractor for the first time. Follow proper starting and transmission purging instructions (See "TO START ENGINE" and "PURGE TRANSMISSION" in the Operation section of this manual).

# OPERATION

These symbols may appear on your tractor or in literature supplied with the product. Learn and understand their meaning.



BATTERY



CAUTION OR WARNING



REVERSE



FORWARD



FAST



SLOW



ENGINE ON



ENGINE OFF



OIL PRESSURE



CLUTCH



LIGHTS ON



LIGHTS OFF



FUEL



CHOKE



MOWER HEIGHT

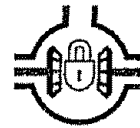

DIFFERENTIAL LOCK



PARKING BRAKE LOCKED



UNLOCKED



MOWER LIFT

**R**

REVERSE

**N**

NEUTRAL

**H**

HIGH

**L**

LOW



PARKING BRAKE



ATTACHMENT CLUTCH ENGAGED



ATTACHMENT CLUTCH DISENGAGED



IGNITION



DANGER, KEEP HANDS AND FEET AWAY

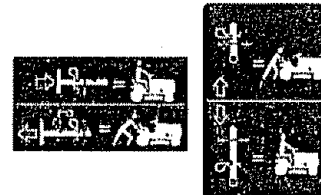

HYDROSTATIC FREE WHEEL  
(Hydro Models only)

# OPERATION

## KNOW YOUR TRACTOR

### READ THIS OWNER'S MANUAL AND SAFETY RULES BEFORE OPERATING YOUR TRACTOR

Compare the illustrations with your tractor to familiarize yourself with the locations of various controls and adjustments. Save this manual for future reference.

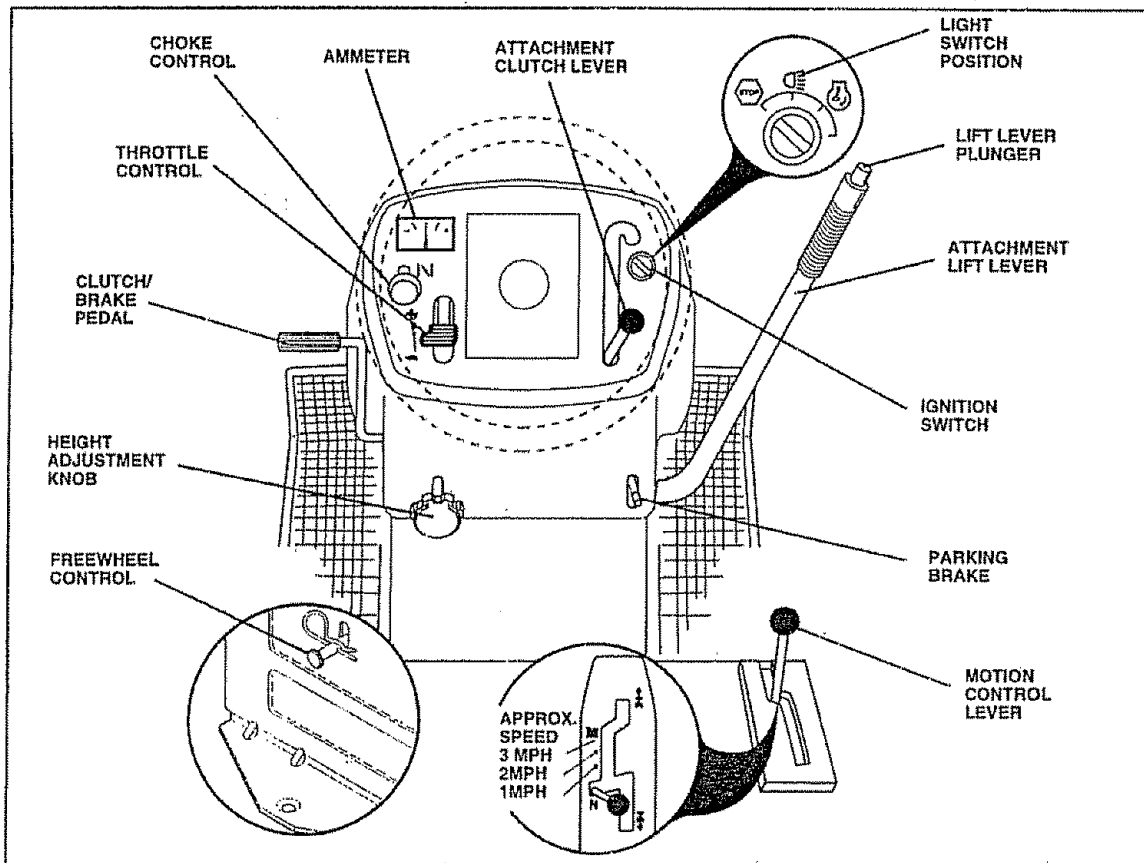

FIG. 7

Our tractors conform to the safety standards of the American National Standards Institute.

**ATTACHMENT CLUTCH LEVER:** Used to engage the mower blades, or other attachments mounted to your tractor.

**LIGHT SWITCH:** Turns the headlights on and off.

**THROTTLE CONTROL:** Used to control engine speed.

**CLUTCH/BRAKE PEDAL:** Used for declutching and braking the tractor and starting the engine.

**PARKING BRAKE:** Locks clutch/brake pedal into the brake position.

**FREEWHEEL CONTROL:** Disengages transmission for pushing or slowly towing the tractor with the engine off.

**CHOKER CONTROL:** Used when starting a cold engine.

**MOTION CONTROL LEVER:** Selects the speed and direction of the tractor.

**ATTACHMENT LIFT LEVER:** Used to raise and lower the mower deck or other attachments mounted to your tractor.

**LIFT LEVER PLUNGER:** Used to release attachment lift lever when changing its position.

**IGNITION SWITCH:** Used for starting and stopping the engine.

**HEIGHT ADJUSTMENT KNOB:** Used to adjust the mower cutting height.

**AMMETER:** Indicates battery charging (+) or discharging (-).

# OPERATION



The operation of any tractor can result in foreign objects thrown into the eyes, which can result in severe eye damage. Always wear safety glasses or eye shields while operating your tractor or performing any adjustments or repairs. We recommend a wide vision safety mask over the spectacles or standard safety glasses.

## HOW TO USE YOUR TRACTOR

### TO SET PARKING BRAKE (See Fig. 8)

Your tractor is equipped with an operator presence sensing switch. When engine is running, any attempt by the operator to leave the seat without first setting the parking brake will shut off the engine.

- Depress clutch/brake pedal into full "BRAKE" position and hold.
- Place parking brake lever in "ENGAGED" position and release pressure from clutch/brake pedal. Pedal should remain in "BRAKE" position. Make sure parking brake will hold tractor secure.

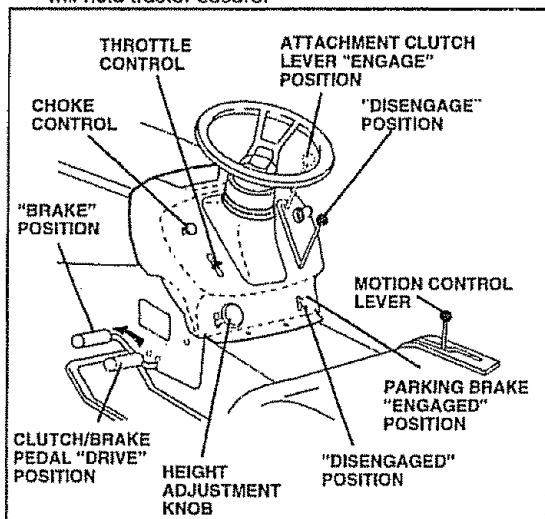

FIG. 8

### STOPPING (See Fig. 8)

#### MOWER BLADES -

- Move attachment clutch lever to "DISENGAGED" position.

#### GROUND DRIVE -

- Depress clutch/brake pedal into full "BRAKE" position.
- Move motion control lever to neutral (N) position.

**IMPORTANT:** THE MOTION CONTROL LEVER DOES NOT RETURN TO NEUTRAL (N) POSITION WHEN THE CLUTCH/BRAKE PEDAL IS DEPRESSED.

#### ENGINE -

- Move throttle control to slow (🐢) position.

**NOTE:** Failure to move throttle control to slow (🐢) position and allowing engine to idle before stopping may cause engine to "backfire".

- Turn ignition key to "OFF" position and remove key. Always remove key when leaving tractor to prevent unauthorized use.
- Never use choke to stop engine.

**NOTE:** Under certain conditions when tractor is standing idle with the engine running, hot engine exhaust gases may cause "browning" of grass. To eliminate this possibility, always stop engine when stopping tractor on grass areas.



**CAUTION:** Always stop tractor completely, as described above, before leaving the operator's position; to empty grass catcher, etc.

### TO USE THROTTLE CONTROL (See Fig. 8)

Always operate engine at full throttle.

- Operating engine at less than full throttle reduces the battery charging rate.
- Full throttle offers the best bagging and mower performance.

### TO USE CHOKE CONTROL (See Fig. 8)

Use choke control whenever you are starting a cold engine. Do not use to start a warm engine.

- To engage choke control, pull knob out. Slowly push knob in to disengage.

### TO MOVE FORWARD AND BACKWARD (See Fig. 8)

The direction and speed of movement is controlled by the motion control lever.

- Start tractor with motion control lever in neutral (N) position.
- Release parking brake and clutch/brake pedal.
- Slowly move motion control lever to desired position.

### TO ADJUST MOWER CUTTING HEIGHT (See Fig. 8)

The cutting height is controlled by turning the height adjustment knob in desired direction.

- Turn knob clockwise (↻) to raise cutting height.
- Turn knob counterclockwise (↺) to lower cutting height.

The cutting height range is approximately 1-1/2" to 4". The heights are measured from the ground to the blade tip with the engine not running. These heights are approximate and may vary depending upon soil conditions, height of grass and types of grass being mowed.

- The average lawn should be cut to approximately 2-1/2 inches during the cool season and to over 3 inches during hot months. For healthier and better looking lawns, mow often and after moderate growth.
- For best cutting performance, grass over 6 inches in height should be mowed twice. Make the first cut relatively high; the second to desired height.

### TO ADJUST GAUGE WHEELS (See Fig. 9)

Adjust gauge wheels with tractor on a flat level surface.

- Adjust mower to desired cutting height (See "TO ADJUST MOWER CUTTING HEIGHT" in the Operation section of this manual).

# OPERATION

- With mower in desired height of cut position, gauge wheels should be assembled so they are slightly off the ground. Install gauge wheel in appropriate hole with shoulder bolt, 3/8 washer, and 3/8-16 locknut and tighten securely.
- Repeat for opposite side installing gauge wheel in same adjustment hole.

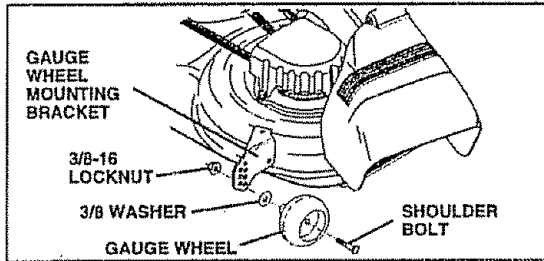

FIG. 9

## TO OPERATE MOWER (See Fig. 10)

Your tractor is equipped with an operator presence sensing switch. Any attempt by the operator to leave the seat with the engine running and the attachment clutch engaged will shut off the engine.

- Select desired height of cut.
- Lower mower with attachment lift control.
- Start mower blades by engaging attachment clutch control.
- TO STOP MOWER BLADES - disengage attachment clutch control.



**CAUTION:** Do not operate the mower without either the entire grass catcher, on mowers so equipped, or the discharge guard in place.

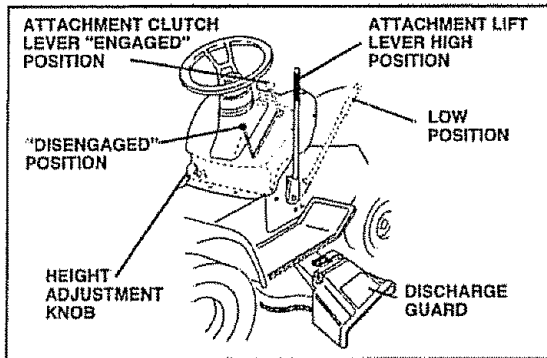

FIG. 10

## TO OPERATE ON HILLS



**CAUTION:** Do not drive up or down hills with slopes greater than 15° and do not drive across any slope.

- Choose the slowest speed before starting up or down hills.
- Avoid stopping or changing speed on hills.
- If slowing is necessary, move throttle control lever to slower position.

- If stopping is absolutely necessary, push clutch/brake pedal quickly to brake position and engage parking brake.
- Move motion control lever to neutral (N) position.  
**IMPORTANT:** THE MOTION CONTROL LEVER DOES NOT RETURN TO NEUTRAL (N) POSITION WHEN THE CLUTCH/BRAKE PEDAL IS DEPRESSED.
- To restart movement, slowly release parking brake and clutch/brake pedal.
- Slowly move motion control lever to slowest setting.
- Make all turns slowly

## TO TRANSPORT (See Fig. 11)

When pushing or towing your tractor, be sure to disengage transmission by placing freewheel control in freewheeling position. Free wheel control is located at the rear drawbar of tractor.

- Raise attachment lift to highest position with attachment lift control.
- Pull freewheel control knob out and hold in position by inserting retainer spring into forward hole of control rod.
- Do not push or tow tractor at more than two (2) MPH.
- To reengage transmission, reverse above procedure.

**NOTE:** To protect hood from damage when transporting your tractor on a truck or a trailer, be sure hood is closed and secured to tractor. Use an appropriate means of tying hood to tractor (rope, cord, etc.).

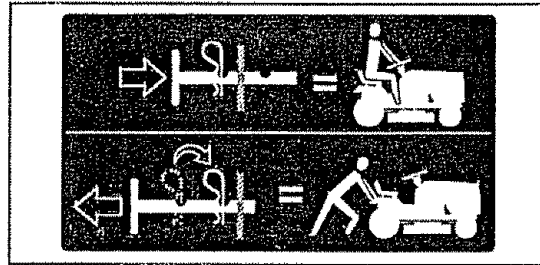

FIG. 11

## BEFORE STARTING THE ENGINE

### CHECK ENGINE OIL LEVEL (See Fig. 15)

- The engine in your tractor has been shipped, from the factory, already filled with summer weight oil.
- Check engine oil with tractor on level ground.
- Remove oil fill cap/dipstick and wipe clean, reinsert the dipstick and screw cap tight, wait for a few seconds, remove and read oil level. If necessary, add oil until "FULL" mark on dipstick is reached. Do not overfill.
- For cold weather operation you should change oil for easier starting (See "OIL VISCOSITY CHART" in the Customer Responsibilities section of this manual).
- To change engine oil, see the Customer Responsibilities section in this manual.

### ADD GASOLINE

- Fill fuel tank. Use fresh, clean, regular unleaded gasoline with a minimum of 87 octane. (Use of leaded gasoline will increase carbon and lead oxide deposits and reduce valve life). Do not mix oil with gasoline. Purchase fuel in quantities that can be used within 30 days to assure fuel freshness.

**IMPORTANT:** WHEN OPERATING IN TEMPERATURES BELOW 32°F (0°C), USE FRESH, CLEAN WINTER GRADE GASOLINE TO HELP INSURE GOOD COLD WEATHER STARTING.

# OPERATION

**WARNING:** Experience indicates that alcohol blended fuels (called gasohol or using ethanol or methanol) can attract moisture which leads to separation and formation of acids during storage. Acidic gas can damage the fuel system of an engine while in storage. To avoid engine problems, the fuel system should be emptied before storage of 30 days or longer. Drain the gas tank, start the engine and let it run until the fuel lines and carburetor are empty. Use fresh fuel next season. See Storage Instructions for additional information. Never use engine or carburetor cleaner products in the fuel tank or permanent damage may occur.



**CAUTION:** Fill to bottom of gas tank filler neck. Do not overfill. Wipe off any spilled oil or fuel. Do not store, spill or use gasoline near an open flame.

## TO START ENGINE (See Fig. 8)

When starting the engine for the first time or if the engine has run out of fuel, it will take extra cranking time to move fuel from the tank to the engine.

- Depress clutch/brake pedal and set parking brake.
- Place motion control lever in neutral (N) position.
- Move attachment clutch to "DISENGAGED" position.
- Move throttle control to fast (F) position.
- Pull choke control out for a cold engine start attempt. For a warm engine start attempt the choke control may not be needed.

**Note:** Before starting, read the warm and cold starting procedures below.

- Insert key into ignition and turn key clockwise to "START" position and release key as soon as engine starts. Do not run starter continuously for more than fifteen seconds per minute. If the engine does not start after several attempts, push choke control in, wait a few minutes and try again. If engine still does not start, pull the choke control out and retry.

## WARM WEATHER STARTING (50° F and above)

- When engine starts, slowly push choke control in until the engine begins to run smoothly. If the engine starts to run roughly, pull the choke control out slightly for a few seconds and then continue to push the control in slowly.
- The attachments and ground drive can now be used. If the engine does not accept the load, restart the engine and allow it to warm up for one minute using the choke as described above.

## COLD WEATHER STARTING (50° F and below)

- When engine starts, slowly push choke control in until the engine begins to run smoothly. Continue to push the choke control in small steps allowing the engine to accept small changes in speed and load, until the choke control is fully in. If the engine starts to run roughly, pull the choke control out slightly for a few seconds and then continue to push the control in slowly. This may require an engine warm-up period from several seconds to several minutes, depending on the temperature.

## HYDROSTATIC TRANSMISSION WARM UP

- Before driving the unit in cold weather, the transmission should be warmed up as follows:
  - Be sure the tractor is on level ground.

- Place the motion control lever in neutral. Release the parking brake and let the clutch/brake slowly return to operating position.
- Allow one minute for transmission to warm up. This can be done during the engine warm up period.
- The attachments can be used during the engine warm-up period after the transmission has been warmed up and may require the choke control be pulled out slightly.

**NOTE:** If at a high altitude (above 3000 feet) or in cold temperatures (below 32 F) the carburetor fuel mixture may need to be adjusted for best engine performance. See "TO ADJUST CARBURETOR" in the Service and Adjustments section of this manual.

## PURGE TRANSMISSION



**CAUTION:** Never engage or disengage freewheel lever while the engine is running.

To ensure proper operation and performance, it is recommended that the transmission be purged before operating tractor for the first time. This procedure will remove any trapped air inside the transmission which may have developed during shipping of your tractor.

**IMPORTANT:** SHOULD YOUR TRANSMISSION REQUIRE REMOVAL FOR SERVICE OR REPLACEMENT, IT SHOULD BE PURGED AFTER REINSTALLATION BEFORE OPERATING THE TRACTOR.

- Place tractor safely on level surface with engine off and parking brake set.
- Disengage transmission by placing freewheel control in freewheeling position (See "TO TRANSPORT" in this section of manual).
- Sitting in the tractor seat, start engine. After the engine is running, move throttle control to slow (S) position. With motion control lever in neutral (N) position, slowly disengage clutch/brake pedal.
- Move motion control lever to full forward position and hold for five (5) seconds. Move lever to full reverse position and hold for five (5) seconds. Repeat this procedure three (3) times.

**NOTE:** During this procedure there will be no movement of drive wheels. The air is being removed from hydraulic drive system.

- Move motion control lever to neutral (N) position. Shut-off engine and set parking brake.
- Engage transmission by placing freewheel control in driving position (See "TO TRANSPORT" in this section of manual).
- Sitting in the tractor seat, start engine. After the engine is running, move throttle control to half (1/2) speed. With motion control lever in neutral (N) position, slowly disengage clutch/brake pedal.
- Slowly move motion control lever forward, after the tractor moves approximately five (5) feet, slowly move motion control lever to reverse position. After the tractor moves approximately five (5) feet return the motion control lever to the neutral (N) position. Repeat this procedure with the motion control lever three (3) times.
- Your tractor is now purged and now ready for normal operation.

# OPERATION

## MOWING TIPS

- Tire chains cannot be used when the mower housing is attached to tractor.
- Mower should be properly leveled for best mowing performance. See "TO LEVEL MOWER HOUSING" in the Service and Adjustments section of this manual.
- The left hand side of mower should be used for trimming.
- Drive so that clippings are discharged onto the area that has been cut. Have the cut area to the right of the tractor. This will result in a more even distribution of clippings and more uniform cutting.
- When mowing large areas, start by turning to the right so that clippings will discharge away from shrubs, fences, driveways, etc. After one or two rounds, mow in the opposite direction making left hand turns until finished (See Fig. 12A).
- If grass is extremely tall, it should be mowed twice to reduce load and possible fire hazard from dried clippings. Make first cut relatively high; the second to the desired height.
- Do not mow grass when it is wet. Wet grass will plug mower and leave undesirable clumps. Allow grass to dry before mowing.
- Always operate engine at full throttle when mowing to assure better mowing performance and proper discharge of material. Regulate ground speed by selecting a low enough gear to give the mower cutting performance as well as the quality of cut desired.
- When operating attachments, select a ground speed that will suit the terrain and give best performance of the attachment being used.

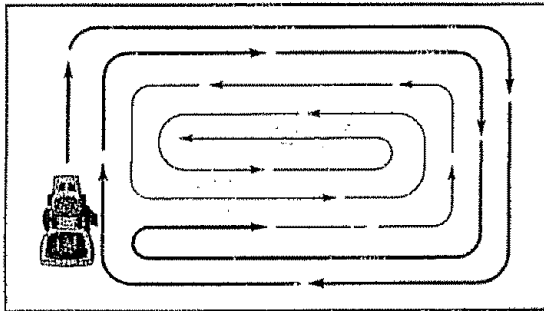

FIG. 12A

## MULCHING MOWING TIPS

**IMPORTANT:** FOR BEST PERFORMANCE, KEEP MOWER HOUSING FREE OF BUILT-UP GRASS AND TRASH. CLEAN AFTER EACH USE.

- The special mulching blade will recut the grass clippings many times and reduce them in size so that as they fall onto the lawn they will disperse into the grass and not be noticed. Also, the mulched grass will biodegrade quickly to provide nutrients for the lawn. Always mulch with your highest engine (blade) speed as this will provide the best recutting action of the blades.
- Avoid cutting your lawn when it is wet. Wet grass tends to form clumps and interferes with the mulching action. The best time to mow your lawn is the early afternoon. At this time the grass has dried and the newly cut area will not be exposed to the direct sun.
- For best results, adjust the mower cutting height so that the mower cuts off only the top one-third of the grass blades (See Fig. 12B). For extremely heavy mulching, reduce your width of cut and mow slowly.
- Certain types of grass and grass conditions may require that an area be mulched a second time to completely hide the clippings. When doing a second cut, mow across or perpendicular to the first cut path.
- Change your cutting pattern from week to week. Mow north to south one week then change to east to west the next week. This will help prevent matting and graining of the lawn.

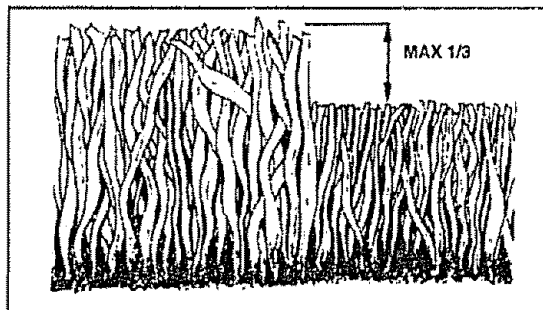

FIG. 12B

# CUSTOMER RESPONSIBILITIES

MAINTENANCE SCHEDULE		BEFORE EACH USE							SERVICE DATES				
FILL IN DATES AS YOU COMPLETE REGULAR SERVICE		BEFORE EACH USE	FIRST 2 HOURS	EVERY 8 HOURS	EVERY 25 HOURS	EVERY 50 HOURS	EVERY 100 HOURS	EVERY SEASON	BEFORE STORAGE				
TRACTOR	Check Brake Operation	✓	✓										
	Check Tire Pressure	✓	✓										
	Check for Loose Fasteners	✓					✓ <sub>7</sub>	✓					
	Sharpen/Replace Mower Blades				✓ <sub>1</sub>								
	Lubrication Chart			✓				✓					
	Check Battery Level/Recharge			✓ <sub>6</sub>									
	Clean Battery and Terminals			✓				✓					
	Check Transaxle Cooling			✓									
	Adjust Blade Belt(s) Tension						✓ <sub>5</sub>						
	Adjust Motion Drive Belt(s) Tension						✓ <sub>6</sub>						
ENGINE	Check Engine Oil Level	✓	✓										
	Change Engine Oil		✓	✓ <sub>1,2,3</sub>				✓					
	Clean Air Filter			✓ <sub>2</sub>									
	Clean Air Screen			✓ <sub>2</sub>									
	Inspect Muffler/Spark Arrester				✓								
	Replace Oil Filter (If equipped)						✓ <sub>1,2</sub>						
	Clean Engine Cooling Fins						✓ <sub>2</sub>						
	Replace Spark Plug						✓	✓					
	Replace Air Filter Paper Cartridge						✓ <sub>2</sub>						
	Replace Fuel Filter							✓					

1 - Change more often when operating under a heavy load or in high ambient temperatures  
 2 - Service more often when operating in dirty or dusty conditions  
 3 - If equipped with oil filter, change oil every 50 hours  
 4 - Replace blades more often when mowing in sandy soil.

5 - If equipped with adjustable system  
 6 - Not required if equipped with maintenance-free battery  
 7 - Tighten front axle pivot bolt to 35 ft.-lbs. maximum.  
 Do not overtighten.

## GENERAL RECOMMENDATIONS

The warranty on this tractor does not cover items that have been subjected to operator abuse or negligence. To receive full value from the warranty, operator must maintain tractor as instructed in this manual.

Some adjustments will need to be made periodically to properly maintain your tractor.

All adjustments in the Service and Adjustments section of this manual should be checked at least once each season.

- Once a year you should replace the spark plug, clean or replace air filter, and check blades and belts for wear. A new spark plug and clean air filter assure proper air-fuel mixture and help your engine run better and last longer.

## BEFORE EACH USE

- Check engine oil level.
- Check brake operation.
- Check tire pressure.
- Check for loose fasteners.

## LUBRICATION CHART

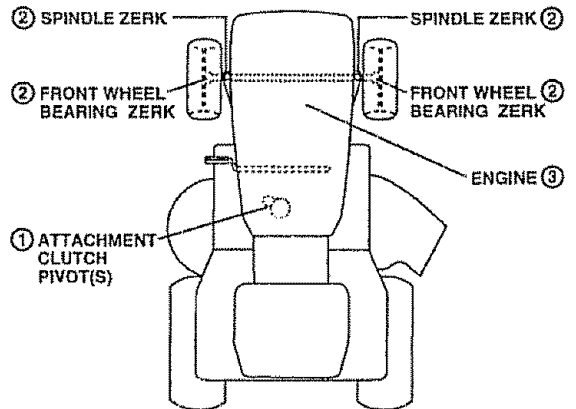

- ① SAE 30 OR 10W30 MOTOR OIL
  - ② GENERAL PURPOSE GREASE
  - ③ REFER TO CUSTOMER RESPONSIBILITIES "ENGINE" SECTION
- IMPORTANT: DO NOT OIL OR GREASE THE PIVOT POINTS WHICH HAVE SPECIAL NYLON BEARINGS. VISCOUS LUBRICANTS WILL ATTRACT DUST AND DIRT THAT WILL SHORTEN THE LIFE OF THE SELF-LUBRICATING BEARINGS. IF YOU FEEL THEY MUST BE LUBRICATED, USE ONLY A DRY, POWDERED GRAPHITE TYPE LUBRICANT SPARINGLY.

# CUSTOMER RESPONSIBILITIES

## TRACTOR

Always observe safety rules when performing any maintenance.

## BRAKE OPERATION

If tractor requires more than six (6) feet stopping distance at high speed in highest gear, then brake must be adjusted. (See "TO ADJUST BRAKE" in the Service and Adjustments section of this manual).

## TIRES

- Maintain proper air pressure in all tires (See "PRODUCT SPECIFICATIONS" on page 3 of this manual).
- Keep tires free of gasoline, oil, or insect control chemicals which can harm rubber.
- Avoid stumps, stones, deep ruts, sharp objects and other hazards that may cause tire damage.

## BLADE CARE

For best results mower blades must be kept sharp. Replace bent or damaged blades.

## BLADE REMOVAL (See Fig. 13)

- Raise mower to highest position to allow access to blades.
- Remove hex bolt, lock washer and flat washer securing blade.
- Install new or resharpened blade with trailing edge up towards deck as shown.
- Reassemble hex bolt, lock washer and flat washer in exact order as shown.
- Tighten bolt securely (30-35 Ft. Lbs. torque).

**IMPORTANT:** BLADE BOLT IS GRADE 8 HEAT TREATED.

**NOTE:** We do not recommend sharpening blade - but if you do, be sure the blade is balanced.

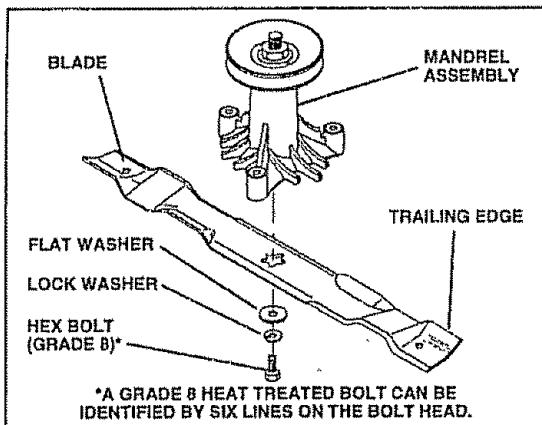

FIG. 13

## TO SHARPEN BLADE (See Fig. 14)

Care should be taken to keep the blade balanced. An unbalanced blade will cause excessive vibration and eventual damage to mower and engine.

- The blade can be sharpened with a file or on a grinding wheel. Do not attempt to sharpen while on the mower.
- To check blade balance, you will need a 5/8" diameter steel bolt, pin, or a cone balancer. (When using a cone balancer, follow the instructions supplied with balancer).
- Slide blade on to an unthreaded portion of the steel bolt or pin and hold the bolt or pin parallel with the ground. If blade is balanced, it should remain in a horizontal position. If either end of the blade moves downward, sharpen the heavy end until the blade is balanced.

**NOTE:** Do not use a nail for balancing blade. The lobes of the center hole may appear to be centered, but are not.

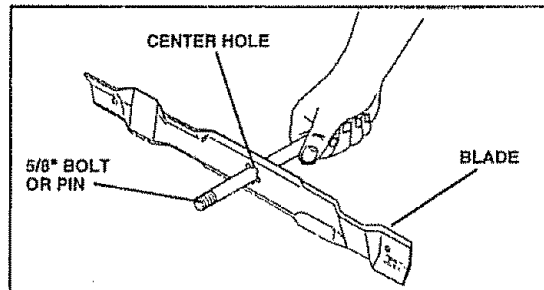

FIG. 14

## BATTERY

Your tractor has a battery charging system which is sufficient for normal use. However, periodic charging of the battery with an automotive charger will extend its life.

- Keep battery and terminals clean.
- Keep battery bolts tight.
- Keep small vent holes open.
- Recharge at 6-10 amperes for 1 hour.

## TO CLEAN BATTERY AND TERMINALS

Corrosion and dirt on the battery and terminals can cause the battery to "leak" power.

- Remove terminal guard.
- Disconnect BLACK battery cable first then RED battery cable and remove battery from tractor.
- Rinse the battery with plain water and dry.
- Clean terminals and battery cable ends with wire brush until bright.
- Coat terminals with grease or petroleum jelly.
- Reinstall battery (See "CONNECT BATTERY" in the Assembly section of this manual).

# CUSTOMER RESPONSIBILITIES

## V-BELTS

Check V-belts for deterioration and wear after 100 hours of operation and replace if necessary. The belts are not adjustable. Replace belts if they begin to slip from wear.

## TRANSAXLE COOLING

The fan and cooling fins of transmission should be kept clean to assure proper cooling.

Do not attempt to clean fan or transmission while engine is running or while the transmission is hot.

- Inspect cooling fan to be sure fan blades are intact and clean.
- Inspect cooling fins for dirt, grass clippings and other materials. To prevent damage to seals, do not use compressed air or high pressure sprayer to clean cooling fins.

## TRANSAXLE PUMP FLUID

The transaxle was sealed at the factory and fluid maintenance is not required for the life of the transaxle. Should the transaxle ever leak or require servicing, contact your nearest authorized service center/department.

## ENGINE

### LUBRICATION

Only use high quality detergent oil rated with API service classification SF or SG. Select the oil's SAE viscosity grade according to your expected operating temperature.

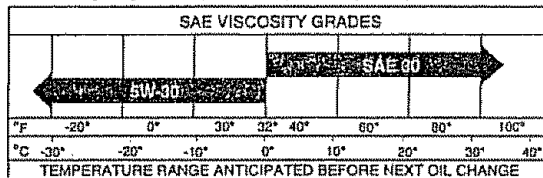

FIG. 15

**NOTE:** Although multi-viscosity oils (5W30, 10W30 etc.) improve starting in cold weather, these multi-viscosity oils will result in increased oil consumption when used above 32°F. Check your engine oil level more frequently to avoid possible engine damage from running low on oil.

Change the oil after the first two hours of operation and every 25 hours thereafter or at least once a year if the tractor is not used for 25 hours in one year.

Check the crankcase oil level before starting the engine and after each eight (8) hours of operation. Tighten oil fill cap/dipstick securely each time you check the oil level.

### TO CHANGE ENGINE OIL (See Figs. 15 and 16)

Determine temperature range expected before oil change. All oil must meet API service classification SF or SG.

- Be sure tractor is on level surface.
- Oil will drain more freely when warm.
- Catch oil in a suitable container.
- Remove oil fill cap/dipstick. Be careful not to allow dirt to enter the engine when changing oil.
- Remove drain plug.

- After oil has drained completely, replace oil drain plug and tighten securely.
- Refill engine with oil through oil fill dipstick tube. Pour slowly. Do not overfill. For approximate capacity see "PRODUCT SPECIFICATIONS" on page 3 of this manual.
- Use gauge on oil fill cap/dipstick for checking level. Be sure dipstick cap is tightened securely for accurate reading. Keep oil at "FULL" line on dipstick.

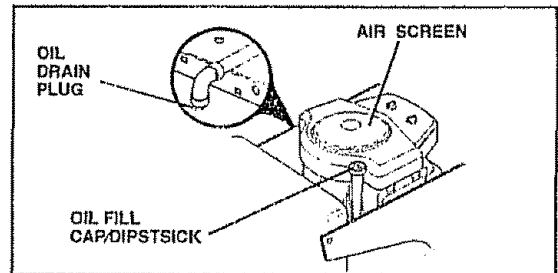

FIG. 16

### CLEAN AIR SCREEN (See Fig. 16)

Air screen must be kept free of dirt and chaff to prevent engine damage from overheating. Clean with a wire brush or compressed air to remove dirt and stubborn dried gum fibers.

### AIR FILTER (See Fig. 17)

Your engine will not run properly using a dirty air filter. Clean the foam pre-cleaner after every 25 hours of operation or every season. Service paper cartridge every 100 hours of operation or every season, whichever occurs first.

Service air cleaner more often under dusty conditions.

- Remove knob(s) and cover.

### TO SERVICE PRE-CLEANER

- Slide foam pre-cleaner off cartridge.
- Wash it in liquid detergent and water.
- Squeeze it dry in a clean cloth.
- Saturate it in engine oil. Wrap it in clean, absorbent cloth and squeeze to remove excess oil.
- If very dirty or damaged, replace pre-cleaner.
- Reinstall pre-cleaner over cartridge.
- Reinstall cover and secure with knob(s).

### TO SERVICE CARTRIDGE

- Remove wing nuts and cartridge plate.
- Carefully remove cartridge to prevent debris from entering carburetor.
- Clean cartridge by tapping gently on flat surface. If very dirty or damaged, replace cartridge.
- Reinstall cartridge plate, wing nuts, pre-cleaner, cover and secure with knob(s).

# CUSTOMER RESPONSIBILITIES

**IMPORTANT:** PETROLEUM SOLVENTS, SUCH AS KEROSENE, ARE NOT TO BE USED TO CLEAN THE CARTRIDGE. THEY MAY CAUSE DETERIORATION OF THE CARTRIDGE. DO NOT OIL CARTRIDGE. DO NOT USE PRESSURIZED AIR TO CLEAN OR DRY CARTRIDGE.

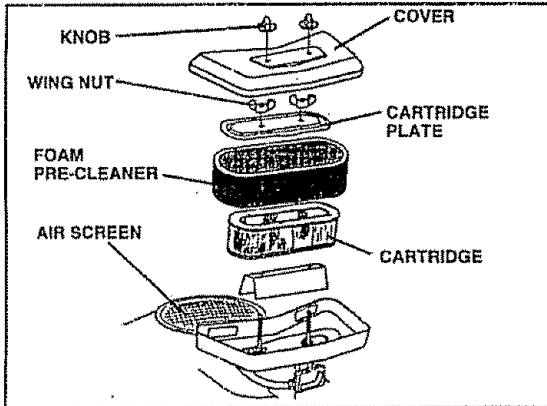

FIG. 17

## ENGINE COOLING FINS (See Fig. 18)

Remove any dust, dirt or oil from engine cooling fins to prevent engine damage from overheating. Air guide covers must be removed. Remove side panels and hood (See "TO REMOVE HOOD AND GRILL ASSEMBLY" in the Service and Adjustments section of this manual).

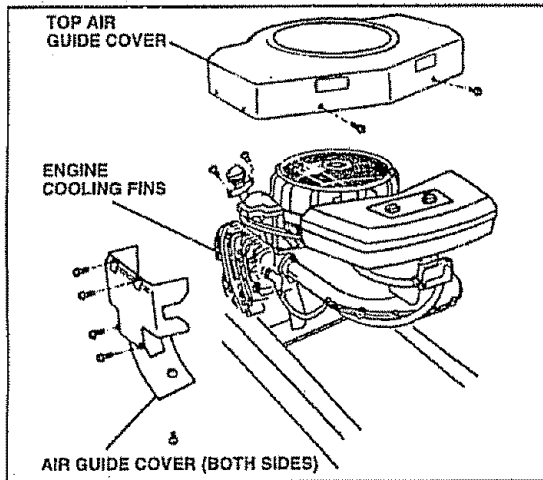

FIG. 18

## MUFFLER

Inspect and replace corroded muffler and spark arrester (if equipped) as it could create a fire hazard and/or damage.

## SPARK PLUGS

Replace spark plugs at the beginning of each mowing season or after every 100 hours of operation, whichever occurs first. Spark plug type and gap setting are shown in "PRODUCT SPECIFICATIONS" on page 3 of this manual.

## IN-LINE FUEL FILTER (See Fig. 19)

The fuel filter should be replaced once each season. If fuel filter becomes clogged, obstructing fuel flow to carburetor, replacement is required.

- With engine cool, remove filter and plug fuel line sections.
- Place new fuel filter in position in fuel line with arrow pointing towards carburetor.
- Be sure there are no fuel line leaks and clamps are properly positioned.
- Immediately wipe up any spilled gasoline.

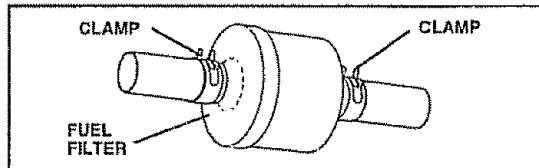

FIG. 19

## CLEANING

- Clean engine, battery, seat, finish, etc. of all foreign matter.
- Keep finished surfaces and wheels free of all gasoline, oil, etc.
- Protect painted surfaces with automotive type wax.

We do not recommend using a garden hose to clean your tractor unless the electrical system, muffler, air filter and carburetor are covered to keep water out. Water in engine can result in a shortened engine life.

# SERVICE AND ADJUSTMENTS



## CAUTION: BEFORE PERFORMING ANY SERVICE OR ADJUSTMENTS:

- Depress clutch/brake pedal fully and set parking brake.
- Place motion control lever in neutral (N) position.
- Place attachment clutch in "DISENGAGED" position.
- Turn ignition key "OFF" and remove key.
- Make sure the blades and all moving parts have completely stopped.
- Disconnect spark plug wire from spark plug and place wire where it cannot come in contact with plug.

## TO REMOVE MOWER (See Fig. 20)

- Place attachment clutch in "DISENGAGED" position.
- Turn height adjustment knob to lowest setting.
- Lower mower to its lowest position.
- Disconnect clutch rod from clutch lever by removing retainer spring.
- Remove retainer spring holding anti-swaybar to chassis bracket and disengage anti-swaybar from bracket.
- Remove retainer springs from suspension arms at deck and disengage arms from deck.
- Raise attachment lift to its highest position.
- Remove two retainer springs from each front link and remove links.

- Slide mower forward and remove belt from engine pulley.
- Slide mower out from under right side of tractor.

**IMPORTANT:** IF AN ATTACHMENT OTHER THAN THE MOWER DECK IS TO BE MOUNTED ON THE TRACTOR, REMOVE THE FRONT LINKS.

## TO INSTALL MOWER

Follow procedure described in "INSTALL MOWER AND DRIVE BELT" in the Assembly section of this manual.

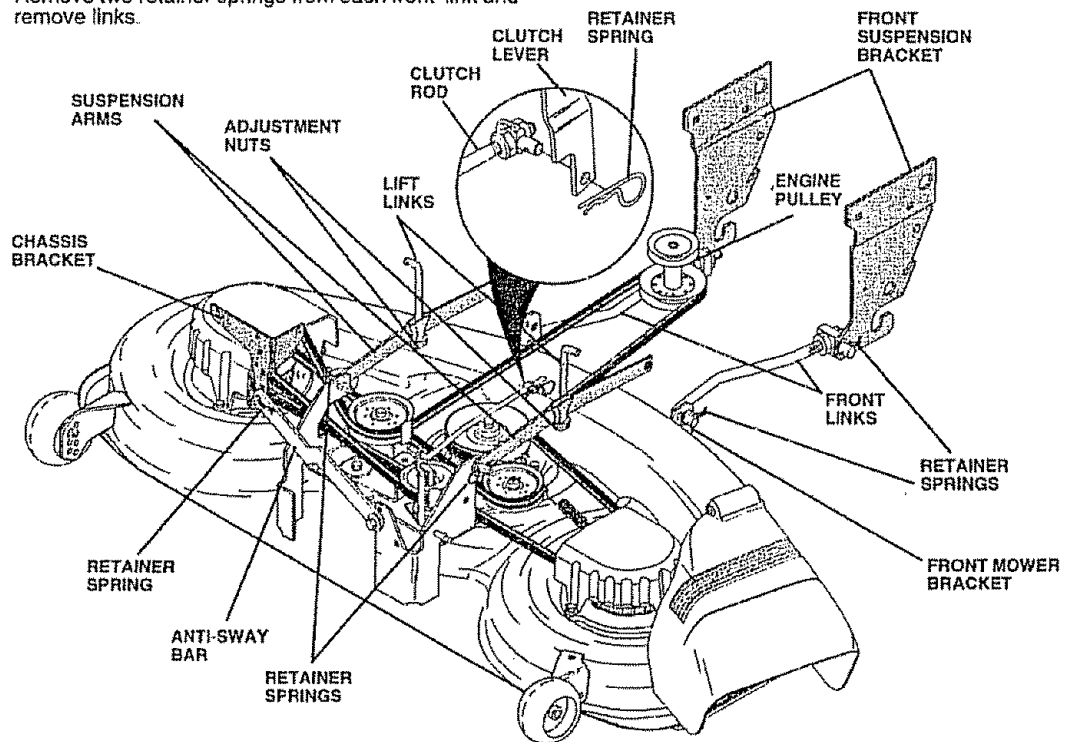

FIG. 20

# SERVICE AND ADJUSTMENTS

## TO LEVEL MOWER HOUSING

Adjust the mower while tractor is parked on level ground or driveway. Make sure tires are properly inflated (See "PRODUCT SPECIFICATIONS" on page 3 of this manual). If tires are over or underinflated, you will not properly adjust your mower.

### SIDE-TO-SIDE ADJUSTMENT (See Figs. 21 and 22)

- Raise mower to its highest position.
- At the midpoint of both sides of mower, measure height from bottom edge of mower to ground. Distance "A" on both sides of mower should be the same or within 1/4" of each other.
- If adjustment is necessary, make adjustment on one side of mower only.
- To raise one side of mower, tighten lift link adjustment nut on that side.
- To lower one side of mower, loosen lift link adjustment nut on that side.

**NOTE:** Each full turn of adjustment nut will change mower height about 1/8".

- Recheck measurements after adjusting.

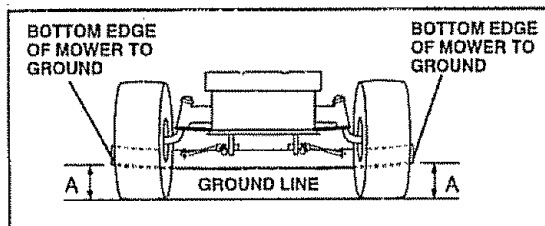

FIG. 21

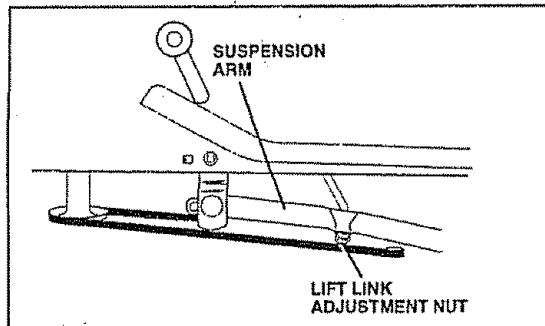

FIG. 22

### FRONT-TO-BACK ADJUSTMENT (See Figs. 23 and 24)

**IMPORTANT:** DECK MUST BE LEVEL SIDE-TO-SIDE IF THE FOLLOWING FRONT-TO-BACK ADJUSTMENT IS NECESSARY, BE SURE TO ADJUST BOTH FRONT LINKS EQUALLY SO MOWER WILL STAY LEVEL SIDE-TO-SIDE.

To obtain the best cutting results, the mower housing should be adjusted so that the front is approximately 1/8" to 1/2" lower than the rear when the mower is in its highest position.

Check adjustment on right side of tractor. Measure distance "D" directly in front and behind the mandrel at bottom edge of mower housing as shown.

- Before making any necessary adjustments, check that both front links are equal in length. Both links should be approximately 10-3/8".
- If links are not equal in length, adjust one link to same length as other link.
- To lower front of mower loosen nut "E" on both front links an equal number of turns.
- When distance "D" is 1/8" to 1/2" lower at front than rear, tighten nuts "F" against trunnion on both front links.
- To raise front of mower, loosen nut "F" from trunnion on both front links. Tighten nut "E" on both front links an equal number of turns.
- When distance "D" is 1/8" to 1/2" lower at front than rear, tighten nut "F" against trunnion on both front links.
- Recheck side-to-side adjustment.

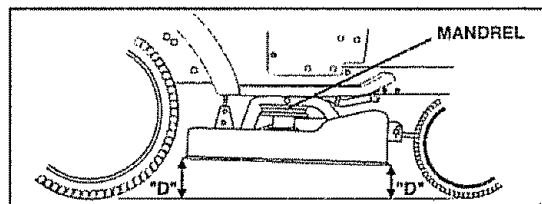

FIG. 23

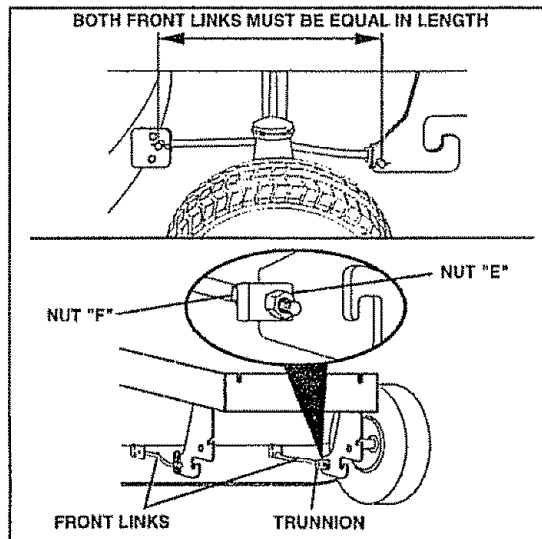

FIG. 24

# SERVICE AND ADJUSTMENTS

## TO REPLACE MOWER DRIVE BELT

### MOWER DRIVE BELT REMOVAL (See Fig. 25)

- Park tractor on a level surface. Engage parking brake. Disengage attachment clutch control.
- Remove four screws from L.H. mandrel cover and remove cover.
- Roll belt over the top of L.H. mandrel pulley.
- Remove belt from engine pulley.
- Remove belt from idler pulleys.
- Remove any dirt or grass clippings which may have accumulated around mandrels and entire upper deck surface.
- Check primary idler arm and two idlers to see that they rotate freely.

### MOWER DRIVE BELT INSTALLATION (See Fig. 25)

- Install belt in both idlers. Make sure belt is in both belt keepers at the idlers as shown.
- Install new belt onto engine pulley
- Roll belt into upper groove of L.H. mandrel pulley.
- Carefully check belt routing making sure belt is in the grooves correctly and inside belt keepers.
- Reassemble L.H. mandrel cover.

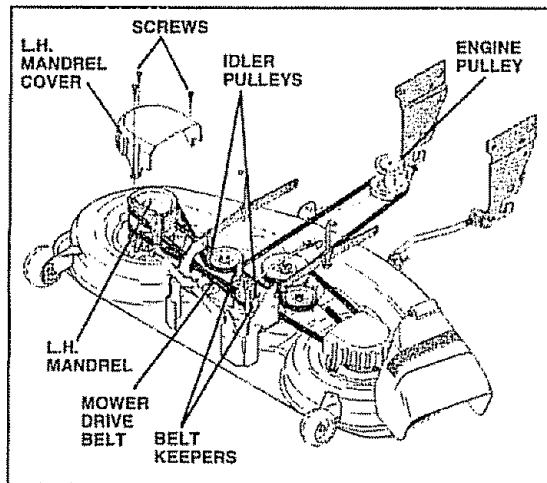

FIG. 25

## TO REPLACE MOWER BLADE DRIVE BELT (See Fig. 26)

Park the tractor on level surface. Engage parking brake.

- Remove mower drive belt (See "TO REPLACE MOWER DRIVE BELT" in this section of this manual).
- Remove mower (See "TO REMOVE MOWER" in this section of this manual).
- Remove four screws from R.H. mandrel cover and remove cover.
- Disconnect secondary clutch rod from pivot rod by removing retainer spring.
- Carefully roll belt off R.H. mandrel pulley.
- Remove belt from center mandrel pulley, idler pulley, and L.H. mandrel pulley.
- Remove any dirt or grass which may have accumulated around mandrels and entire upper deck surface.
- Check secondary idler arm and idler to see that they rotate freely.
- Be sure spring is hooked in secondary idler arm and sway-bar bracket.
- Install new belt in lower groove of L.H. mandrel pulley, idler pulley, and center mandrel pulley as shown.
- Roll belt over R.H. mandrel pulley. Make sure belt is in all grooves properly.
- Reconnect secondary clutch rod to pivot rod with retainer spring.
- Reinstall R.H. mandrel cover.
- Reinstall mower to tractor (See "INSTALL MOWER AND DRIVE BELT" in the Assembly section of this manual).
- Reassemble mower drive belt (See "TO REPLACE MOWER DRIVE BELT" in this section of this manual).

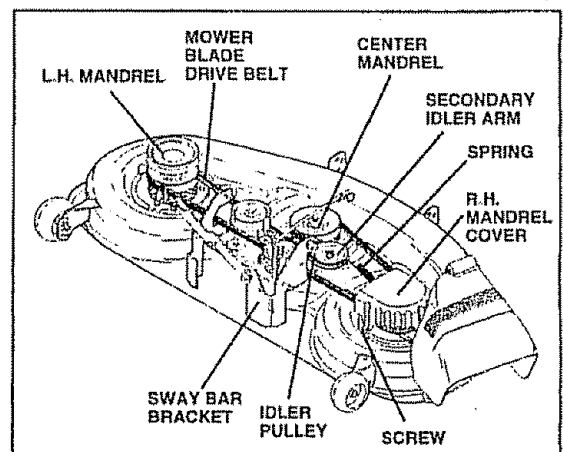

FIG. 26

# SERVICE AND ADJUSTMENTS

## TO ADJUST BRAKE (See Fig. 27)

Your tractor is equipped with an adjustable brake system which is mounted on the side of the transaxle.

If tractor requires more than six (6) feet stopping distance at high speed in highest gear, then brake must be adjusted.

- Depress clutch/brake pedal and engage parking brake.
- Measure distance between brake operating arm and nut "A" on brake rod.
- If distance is other than 1-3/4", loosen jam nut and turn nut "A" until distance becomes 1-3/4". Retighten jam nut against nut "A".
- Road test tractor for proper stopping distance as stated above. Readjust if necessary. If stopping distance is still greater than six (6) feet in highest gear, further maintenance is necessary. Contact your nearest authorized service center/department.

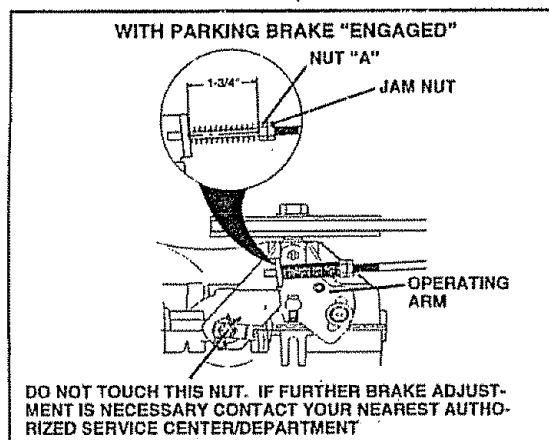

FIG. 27

## TO REPLACE MOTION DRIVE BELT (See Fig. 28)

Park the tractor on level surface. Engage parking brake. For assistance, there is a belt installation guide decal on bottom side of left footrest.

- Remove mower (See "TO REMOVE MOWER" in this section of this manual.)
- Remove upper belt keeper.
- Remove belt from stationary idler and clutching idler.
- Pull belt slack toward rear of tractor. Carefully remove belt upwards from transmission input pulley and over cooling fan blades.
- Pull belt toward front of tractor and remove downward from around engine pulley.
- Install new belt by reversing above procedure.

**IMPORTANT: MAKE SURE UPPER BELT KEEPER IS POSITIONED PROPERLY BETWEEN LOCATOR TABS.**

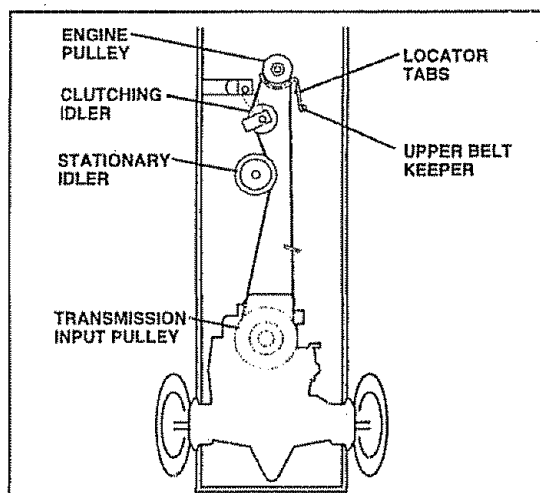

FIG. 28

# SERVICE AND ADJUSTMENTS

## TO ADJUST MOTION CONTROL LEVER (See Fig. 29)

The motion control lever has been preset at the factory and adjustment should not be necessary.

If for any reason the motion control lever will not hold its position while at a selected speed, it may be adjusted at the friction pack located on the right side of transmission.

- Park tractor on level surface. Stop tractor by turning ignition key to "OFF" position, and engage parking brake.
- Adjust motion control lever by tightening adjustment locknut one half (1/2) turn.

**NOTE:** If for any reason the effort to move the motion control lever becomes too excessive, reverse the above adjustment procedure by loosening locknut 1/4 to 1/2 turn. Road test tractor after adjustment and repeat procedure if necessary.

## TRANSMISSION REMOVAL/REPLACEMENT

Should your transmission require removal for service or replacement, it should be purged after reinstallation and before operating the tractor. See "PURGE TRANSMISSION" in the Operation section of this manual.

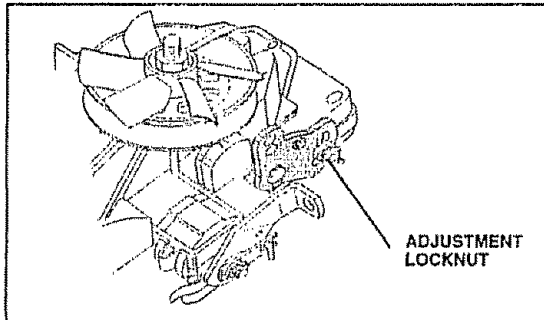

FIG. 29

## TO ADJUST STEERING WHEEL ALIGNMENT

If steering wheel crossbars are not horizontal (left to right) when wheels are positioned straight forward, remove steering wheel and reassemble per Instructions in the Assembly section of this manual.

## FRONT WHEEL TOE-IN/CAMBER

The front wheel toe-in and camber are not adjustable on your tractor. If damage has occurred to affect the front wheel toe-in or camber, contact your nearest authorized service center/department.

## TO REMOVE WHEEL FOR REPAIRS (See Fig. 30)

- Block up axle securely.
- Remove axle cover, retaining ring and washers to allow wheel removal (rear wheel contains a square key - Do not lose).
- Repair tire and reassemble.
- On rear wheels only: align grooves in rear wheel hub and axle. Insert square key.
- Replace washers and snap retaining ring securely in axle groove.
- Replace axle cover.

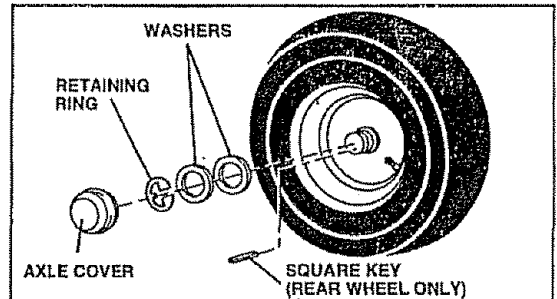

FIG. 30

# SERVICE AND ADJUSTMENTS

## TO START ENGINE WITH A WEAK BATTERY (See Fig. 31)



**CAUTION:** Lead-acid batteries generate explosive gases. Keep sparks, flame and smoking materials away from batteries. Always wear eye protection when around batteries.

If your battery is too weak to start the engine, it should be recharged. If "jumper cables" are used for emergency starting, follow this procedure:

**IMPORTANT:** YOUR TRACTOR IS EQUIPPED WITH A 12 VOLT NEGATIVE GROUNDED SYSTEM. THE OTHER VEHICLE MUST ALSO BE A 12 VOLT NEGATIVE GROUNDED SYSTEM. DO NOT USE YOUR TRACTOR BATTERY TO START OTHER VEHICLES.

### TO ATTACH JUMPER CABLES -

- Connect each end of the RED cable to the POSITIVE (+) terminal of each battery, taking care not to short against chassis.
- Connect one end of the BLACK cable to the NEGATIVE (-) terminal of fully charged battery.
- Connect the other end of the BLACK cable to good CHASSIS GROUND, away from fuel tank and battery

### TO REMOVE CABLES, REVERSE ORDER -

- BLACK cable first from chassis and then from the fully charged battery.
- RED cable last from both batteries.

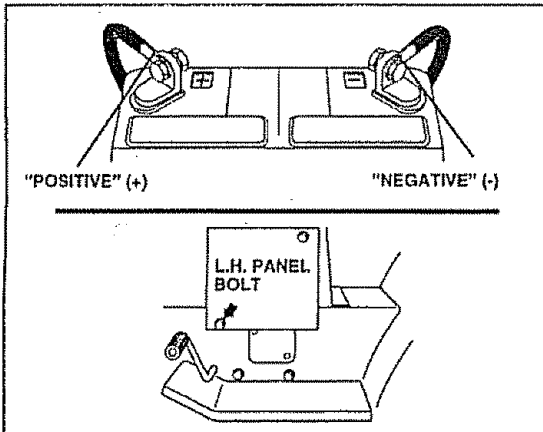

FIG. 31

## TO REPLACE HEADLIGHT BULB

- Raise hood.
- Pull bulb holder out of the hole in the backside of the grill.
- Replace bulb in holder and push bulb holder securely back into the hole in the backside of the grill.
- Close hood.

## INTERLOCKS AND RELAYS

Loose or damaged wiring may cause your tractor to run poorly, stop running, or prevent it from starting.

- Check wiring. See electrical wiring diagram in the Repair Parts section of this manual.

## TO REPLACE FUSE

Replace with 30 amp automotive-type plug-in fuse. The fuse holder is located behind the dash.

## TO REMOVE HOOD AND GRILL ASSEMBLY (See Fig. 32)

- Raise hood
- Unsnap headlight wire connector.
- Stand in front of tractor. Grasp hood at sides, tilt toward engine and lift off of tractor.
- To replace, reverse above procedures.

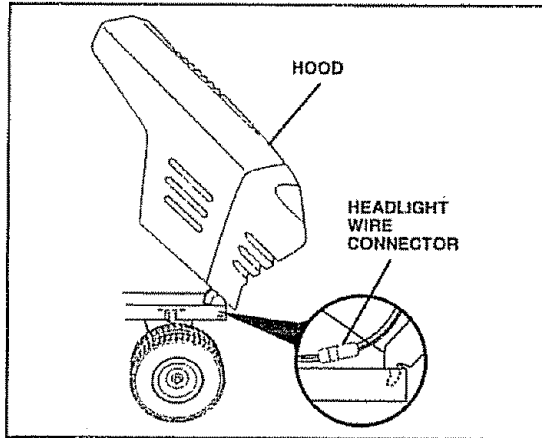

FIG. 32

## ENGINE

### TO ADJUST THROTTLE CONTROL CABLE (See Fig. 33)

The throttle control has been preset at the factory and adjustment should not be necessary. Check adjustment as described below before loosening cable. If adjustment is necessary, proceed as follows:

- With engine not running, move throttle control lever to fast (F) position.
- Check that swivel is against side of quarter circle. If it is not, loosen cable clamp screw and pull cable back until swivel is against quarter circle. Tighten cable clamp screw securely.

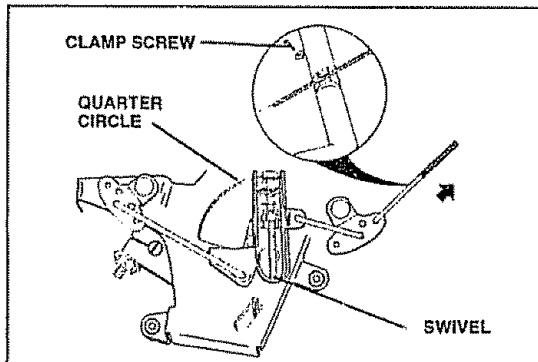

FIG. 33

# SERVICE AND ADJUSTMENTS

## TO ADJUST CHOKE CONTROL (See Fig. 34)

The choke control has been preset at the factory and adjustment should not be necessary. Check adjustment as described below before loosening cable. If adjustment is necessary, proceed as follows:

- With engine not running, move choke control (located on dash panel) to full choke (N) position.
- Remove air cleaner cover, filter and cartridge plate to expose carburetor choke (see "AIR FILTER" in the Customer Responsibilities section of this manual).
- Choke should be closed. If it is not, loosen casing clamp screw and move choke cable until choke is completely closed. Tighten casing clamp screw securely.
- Reassemble air cleaner.

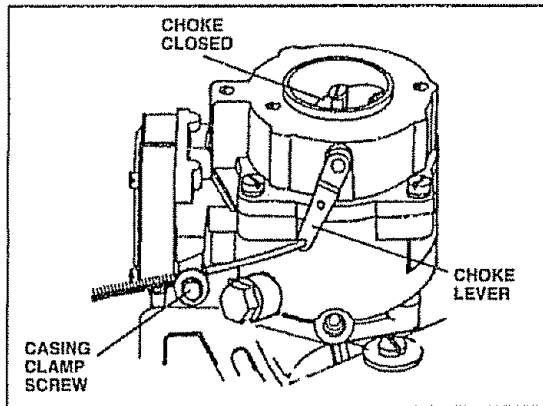

FIG. 34

## TO ADJUST CARBURETOR (See Figs. 35 & 36)

The carburetor has been preset at the factory and adjustment should not be necessary. However, minor adjustment may be required to compensate for differences in fuel, temperature, altitude or load. If the carburetor does need adjustment, proceed as follows:

In general, turning the mixture screw in (clockwise) decreases the supply of fuel to the engine giving a leaner fuel/air mixture. Turning the mixture screw out (counterclockwise) increases the supply of fuel to the engine giving a richer fuel/air mixture.

**IMPORTANT:** DAMAGE TO THE NEEDLES AND THE SEATS IN CARBURETOR MAY RESULT IF SCREW IS TURNED IN TOO TIGHT.

### PRELIMINARY SETTING -

- Be sure you have a clean air filter, and the throttle control cable and choke are adjusted properly (see above).
- With engine off turn idle mixture screw in (clockwise) closing it finger tight and then turn out (counterclockwise) 1-1/4 to 1-1/2 turns.

### FINAL SETTING -

- Start engine and allow to warm for five minutes. Make final adjustments with engine running and shift/motion control lever in neutral (N) position.

- With throttle control lever in slow (S) position, hold throttle lever against idle speed screw and adjust idle speed screw to obtain 1200 to 1400 RPM.
- While still holding throttle lever against idle speed screw, turn idle mixture screw in (clockwise) until engine begins to die and then turn out (counterclockwise) until engine runs rough. Turn screw to a point midway between those two positions.
- Continue to hold throttle lever against idle speed screw and adjust idle speed screw to obtain 900 to 1200 RPM. Release throttle lever.

### ACCELERATION TEST -

- Move throttle control lever from slow (S) to fast (F) position: If engine hesitates or dies, turn idle mixture screw out (counterclockwise) 1/8 turn. Repeat test and continue to adjust, if necessary, until engine accelerates smoothly.

High speed stop is factory adjusted. Do not adjust - damage may result.

**IMPORTANT:** NEVER TAMPER WITH THE ENGINE GOVERNOR, WHICH IS FACTORY SET FOR PROPER ENGINE SPEED. OVERSPEEDING THE ENGINE ABOVE THE FACTORY HIGH SPEED SETTING CAN BE DANGEROUS. IF YOU THINK THE ENGINE-GOVERNED HIGH SPEED NEEDS ADJUSTING, CONTACT YOUR NEAREST AUTHORIZED SERVICE CENTER/DEPARTMENT, WHICH HAS PROPER EQUIPMENT AND EXPERIENCE TO MAKE ANY NECESSARY ADJUSTMENTS.

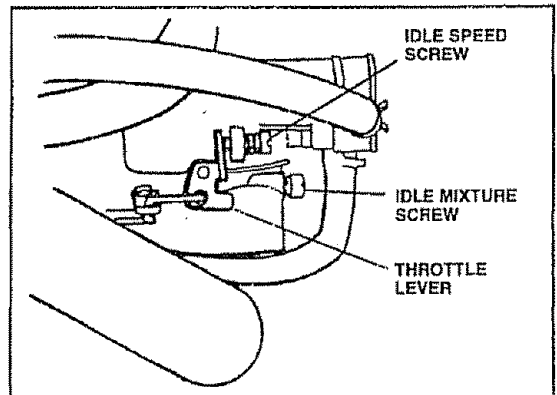

FIG. 35

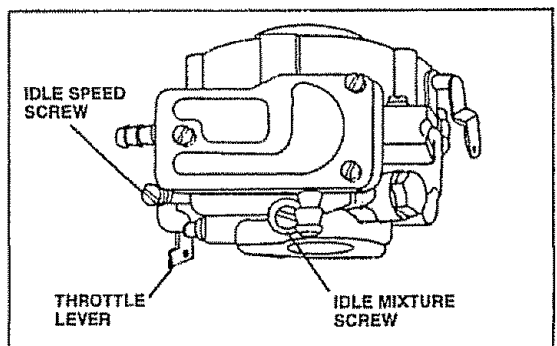

FIG. 36

---

# STORAGE

---

Immediately prepare your tractor for storage at the end of the season or if the tractor will not be used for 30 days or more.



**CAUTION:** Never store the tractor with gasoline in the tank inside a building where fumes may reach an open flame or spark. Allow the engine to cool before storing in any enclosure.

## TRACTOR

Remove mower from tractor for winter storage. When mower is to be stored for a period of time, clean it thoroughly, remove all dirt, grease, leaves, etc. Store in a clean, dry area.

- Clean entire tractor (See "CLEANING" in the Customer Responsibilities section of this manual).
- Inspect and replace belts, if necessary (See belt replacement instructions in the Service and Adjustments section of this manual).
- Lubricate as shown in the Customer Responsibilities section of this manual.
- Be sure that all nuts, bolts and screws are securely fastened. Inspect moving parts for damage, breakage and wear. Replace if necessary.
- Touch up all rusted or chipped paint surfaces; sand lightly before painting.

## BATTERY

- Fully charge the battery for storage.
- After a period of time in storage, battery may require recharging.
- To help prevent corrosion and power leakage during long periods of storage, battery cables should be disconnected and battery cleaned thoroughly (see "TO CLEAN BATTERY AND TERMINALS" in the Customer Responsibilities section of this manual).
- After cleaning, leave cables disconnected and place cables where they cannot come in contact with battery terminals.
- Be sure battery drain tube is securely attached.
- If battery is removed from tractor for storage, do not store battery directly on concrete or damp surfaces.

## ENGINE

### FUEL SYSTEM

**IMPORTANT:** IT IS IMPORTANT TO PREVENT GUM DEPOSITS FROM FORMING IN ESSENTIAL FUEL SYSTEM PARTS SUCH AS CARBURETOR, FUEL FILTER, FUEL HOSE, OR TANK DURING STORAGE. ALSO, EXPERIENCE INDICATES THAT ALCOHOL BLENDED FUELS (CALLED GASOHOL OR USING ETHANOL OR METHANOL) CAN ATTRACT MOISTURE WHICH LEADS TO SEPARATION AND FORMATION OF ACIDS DURING STORAGE. ACIDIC GAS CAN DAMAGE THE FUEL SYSTEM OF AN ENGINE WHILE IN STORAGE.

- Drain the fuel tank.
- Start the engine and let it run until the fuel lines and carburetor are empty.
- Never use engine or carburetor cleaner products in the fuel tank or permanent damage may occur.
- Use fresh fuel next season.

**NOTE:** Fuel stabilizer is an acceptable alternative in minimizing the formation of fuel gum deposits during storage. Add stabilizer to gasoline in fuel tank or storage container. Always follow the mix ratio found on stabilizer container. Run engine at least 10 minutes after adding stabilizer to allow the stabilizer to reach the carburetor. Do not drain the gas tank and carburetor if using fuel stabilizer.

### ENGINE OIL

Drain oil (with engine warm) and replace with clean engine oil. (See "ENGINE" in the Customer Responsibilities section of this manual).

### CYLINDERS

- Remove spark plug(s).
- Pour one ounce of oil through spark plug hole(s) into cylinder(s).
- Turn ignition key to "START" position for a few seconds to distribute oil.
- Replace with new spark plug(s).

### OTHER

- Do not store gasoline from one season to another.
- Replace your gasoline can if your can starts to rust. Rust and/or dirt in your gasoline will cause problems.
- If possible, store your tractor indoors and cover it to give protection from dust and dirt.
- Cover your tractor with a suitable protective cover that does not retain moisture. Do not use plastic. Plastic cannot breathe which allows condensation to form and will cause your tractor to rust.

**IMPORTANT:** NEVER COVER TRACTOR WHILE ENGINE AND EXHAUST AREAS ARE STILL WARM.

# TROUBLESHOOTING POINTS

PROBLEM	CAUSE	CORRECTION
Will not start	<ol style="list-style-type: none"> <li>1 Out of fuel.</li> <li>2 Engine not "CHOKED" properly</li> <li>3 Engine flooded</li> <li>4 Bad spark plug.</li> <li>5 Dirty air filter.</li> <li>6 Dirty fuel filter.</li> <li>7 Water in fuel.</li>   <li>8 Loose or damaged wiring</li> <li>9 Carburetor out of adjustment</li>   <li>10 Engine valves out of adjustment.</li> </ol>	<ol style="list-style-type: none"> <li>1 Fill fuel tank.</li> <li>2 See "TO START ENGINE" in Operation section.</li> <li>3 Wait several minutes before attempting to start</li> <li>4 Replace spark plug.</li> <li>5 Clean/replace air filter.</li> <li>6 Replace fuel filter.</li> <li>7 Drain fuel tank and carburetor. refill tank with fresh gasoline and replace fuel filter.</li> <li>8 Check all wiring.</li> <li>9 See "To Adjust Carburetor" in Service Adjustments section.</li> <li>10 Contact an authorized service center/department.</li> </ol>
Hard to start	<ol style="list-style-type: none"> <li>1 Dirty air filter.</li> <li>2 Bad spark plug</li> <li>3 Weak or dead battery</li> <li>4 Dirty fuel filter.</li> <li>5 Stale or dirty fuel.</li> <li>6 Loose or damaged wiring</li> <li>7 Carburetor out of adjustment.</li>   <li>8 Engine valves out of adjustment</li> </ol>	<ol style="list-style-type: none"> <li>1 Clean/replace air filter</li> <li>2 Replace spark plug.</li> <li>3 Recharge or replace battery</li> <li>4 Replace fuel filter.</li> <li>5 Drain fuel tank and refill with fresh gasoline</li> <li>6 Check all wiring.</li> <li>7 See "To Adjust Carburetor" in Service Adjustments section.</li> <li>8 Contact an authorized service center/department.</li> </ol>
Engine will not turn over	<ol style="list-style-type: none"> <li>1 Clutch/brake pedal not depressed</li> <li>2 Attachment clutch is engaged.</li> <li>3 Weak or dead battery.</li> <li>4 Blown fuse</li> <li>5 Corroded battery terminals</li> <li>6 Loose or damaged wiring</li> <li>7 Faulty ignition switch</li> <li>8 Faulty solenoid or starter</li> <li>9 Faulty operator presence switch(es)</li> </ol>	<ol style="list-style-type: none"> <li>1 Depress clutch/brake pedal.</li> <li>2 Disengage attachment clutch</li> <li>3 Recharge or replace battery.</li> <li>4 Replace fuse.</li> <li>5 Clean battery terminals.</li> <li>6 Check all wiring</li> <li>7 Check/replace ignition switch</li> <li>8 Check/replace solenoid or starter</li> <li>9 Contact an authorized service center/department.</li> </ol>
Engine clicks but will not start	<ol style="list-style-type: none"> <li>1 Weak or dead battery</li> <li>2 Corroded battery terminals.</li> <li>3 Loose or damaged wiring</li> <li>4 Faulty solenoid or starter</li> </ol>	<ol style="list-style-type: none"> <li>1. Recharge or replace battery.</li> <li>2. Clean battery terminals.</li> <li>3. Check all wiring.</li> <li>4. Check/replace solenoid or starter</li> </ol>
Loss of power	<ol style="list-style-type: none"> <li>1. Cutting too much grass/too fast.</li> <li>2. Throttle in "CHOKED" position.</li> <li>3. Build-up of grass, leaves and trash under mower.</li> <li>4. Dirty air filter.</li> <li>5. Low oil level/dirty oil.</li> <li>6. Faulty spark plug.</li> <li>7. Dirty fuel filter</li> <li>8. Stale or dirty fuel</li> <li>9. Water in fuel.</li>   <li>10. Spark plug wire loose</li> <li>11. Dirty engine air screen/lens</li> <li>12. Dirty/clogged muffler.</li> <li>13. Loose or damaged wiring</li> <li>14. Carburetor out of adjustment</li>   <li>15. Engine valves out of adjustment</li> </ol>	<ol style="list-style-type: none"> <li>1. Set in "Higher Cut" position/reduce speed</li> <li>2. Adjust throttle control.</li> <li>3. Clean underside of mower housing.</li> <li>4. Clean/replace air filter.</li> <li>5. Check oil level/change oil</li> <li>6. Clean and regap or change spark plug</li> <li>7. Replace fuel filter</li> <li>8. Drain fuel tank and refill with fresh gasoline.</li> <li>9. Drain fuel tank and carburetor. refill tank with fresh gasoline and replace fuel filter.</li> <li>10. Connect and tighten spark plug wire.</li> <li>11. Clean engine air screen/lens.</li> <li>12. Clean/replace muffler</li> <li>13. Check all wiring.</li> <li>14. See "To Adjust Carburetor" in Service Adjustments section.</li> <li>15. Contact an authorized service center/department.</li> </ol>
Excessive vibration	<ol style="list-style-type: none"> <li>1 Worn, bent or loose blade</li> <li>2 Bent blade mandrel.</li> <li>3. Loose/damaged part(s).</li> </ol>	<ol style="list-style-type: none"> <li>1. Replace blade Tighten blade bolt</li> <li>2. Replace blade mandrel.</li> <li>3. Tighten loose part(s) Replace damaged parts</li> </ol>

# TROUBLESHOOTING POINTS

PROBLEM	CAUSE	CORRECTION
Engine continues to run when operator leaves seat with attachment clutch engaged	1. Faulty operator-safety presence control system	1. Check wiring, switches and connections. If not corrected, contact an authorized service center/department.
Poor cut - uneven	1. Worn, bent or loose blade 2. Mower deck not level 3. Buildup of grass, leaves, and trash under mower 4. Bent blade mandrel 5. Clogged mower deck vent holes from buildup of grass, leaves, and trash around mandrels	1. Replace blade. Tighten blade bolt. 2. Level mower deck. 3. Clean underside of mower housing 4. Replace blade mandrel 5. Clean around mandrels to open vent holes.
Mower blades will not rotate	1. Obstruction in clutch mechanism. 2. Worn/damaged mower drive belt. 3. Frozen idler pulley. 4. Frozen blade mandrel	1. Remove obstruction. 2. Replace mower drive belt 3. Replace idler pulley. 4. Replace blade mandrel
Poor grass discharge	1. Engine speed too slow 2. Travel speed too fast. 3. Wet grass 4. Mower deck not level 5. Low/uneven tire air pressure. 6. Worn, bent or loose blade 7. Buildup of grass, leaves and trash under mower. 8. Mower drive belt worn 9. Blades improperly installed. 10. Improper blades used. 11. Clogged mower deck vent holes from buildup of grass, leaves, and trash around mandrels	1. Place throttle control in "FAST" position. 2. Shift to slower speed. 3. Allow grass to dry before mowing 4. Level mower deck. 5. Check tires for proper air pressure. 6. Replace/sharpen blade. Tighten blade bolt. 7. Clean underside of mower housing 8. Replace mower drive belt. 9. Reinstall blades sharp edge down 10. Replace with blades listed in this manual. 11. Clean around mandrels to open vent holes.
Headlight(s) not working (if so equipped)	1. Switch is "OFF" 2. Bulb(s) burned out 3. Faulty light switch 4. Loose or damaged wiring 5. Blown fuse.	1. Turn switch "ON" 2. Replace bulb(s) 3. Check/replace light switch. 4. Check wiring and connections. 5. Replace fuse.
Battery will not charge	1. Bad battery cell(s) 2. Poor cable connections. 3. Faulty regulator (if so equipped) 4. Faulty alternator.	1. Replace battery 2. Check/clean all connections 3. Replace regulator 4. Replace alternator
Loss of drive	1. Freewheel control in "disengaged" position 2. Motion drive belt worn, damaged, or broken. 3. Air trapped in transmission during shipment or servicing.	1. Place freewheel control in "engaged" position. 2. Replace motion drive belt 3. Purge transmission.
Engine "backfires" when turning engine "OFF"	1. Engine throttle control not set at "SLOW" position for 30 seconds before stopping engine.	1. Move throttle control to "SLOW" position and allow to idle for 30 seconds before stopping engine

# TRACTOR - - MODEL NUMBER 917.258670

## SCHEMATIC

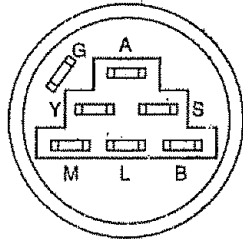
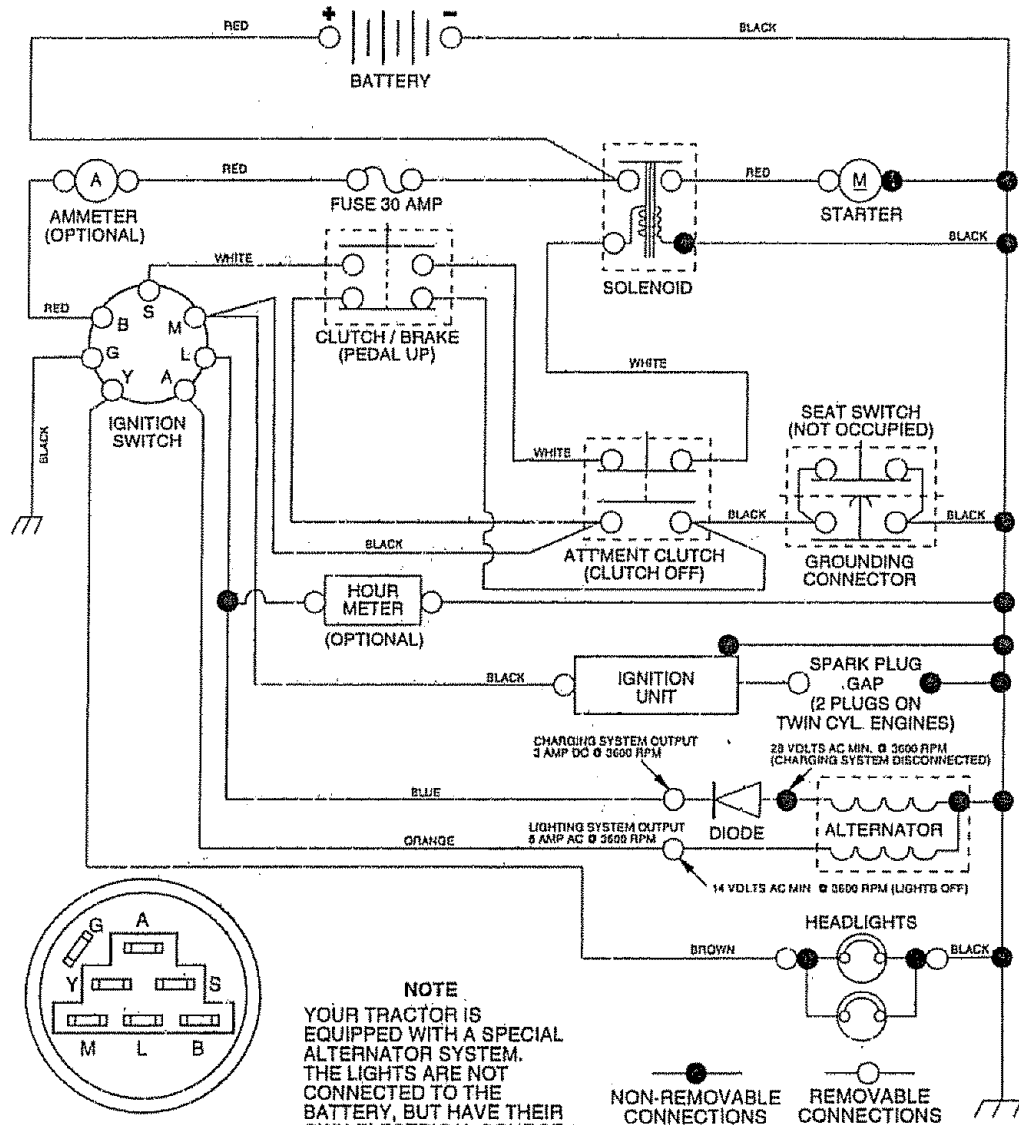

**IGNITION SWITCH**

POSITION	CIRCUIT	"MAKE"
OFF	G + M + L	NONE
RUN/LIGHT	B + L	A + Y
RUN	B + L	NONE
START	B + L + S	NONE

**NOTE**  
YOUR TRACTOR IS EQUIPPED WITH A SPECIAL ALTERNATOR SYSTEM. THE LIGHTS ARE NOT CONNECTED TO THE BATTERY, BUT HAVE THEIR OWN ELECTRICAL SOURCE. BECAUSE OF THIS, THE BRIGHTNESS OF THE LIGHTS WILL CHANGE WITH ENGINE SPEED. AT IDLE THE LIGHTS WILL DIM. AS THE ENGINE IS SPEEDED UP, THE LIGHTS WILL BECOME THEIR BRIGHTEST.

NON-REMOVABLE CONNECTIONS      REMOVABLE CONNECTIONS

**WIRING INSULATED CLIPS**  
**NOTE:** IF WIRING INSULATED CLIPS WERE REMOVED FOR SERVICING OF UNIT, THEY SHOULD BE REPLACED TO PROPERLY SECURE YOUR WIRING

# REPAIR PARTS

TRACTOR -- MODEL NUMBER 917.258670

## ELECTRICAL

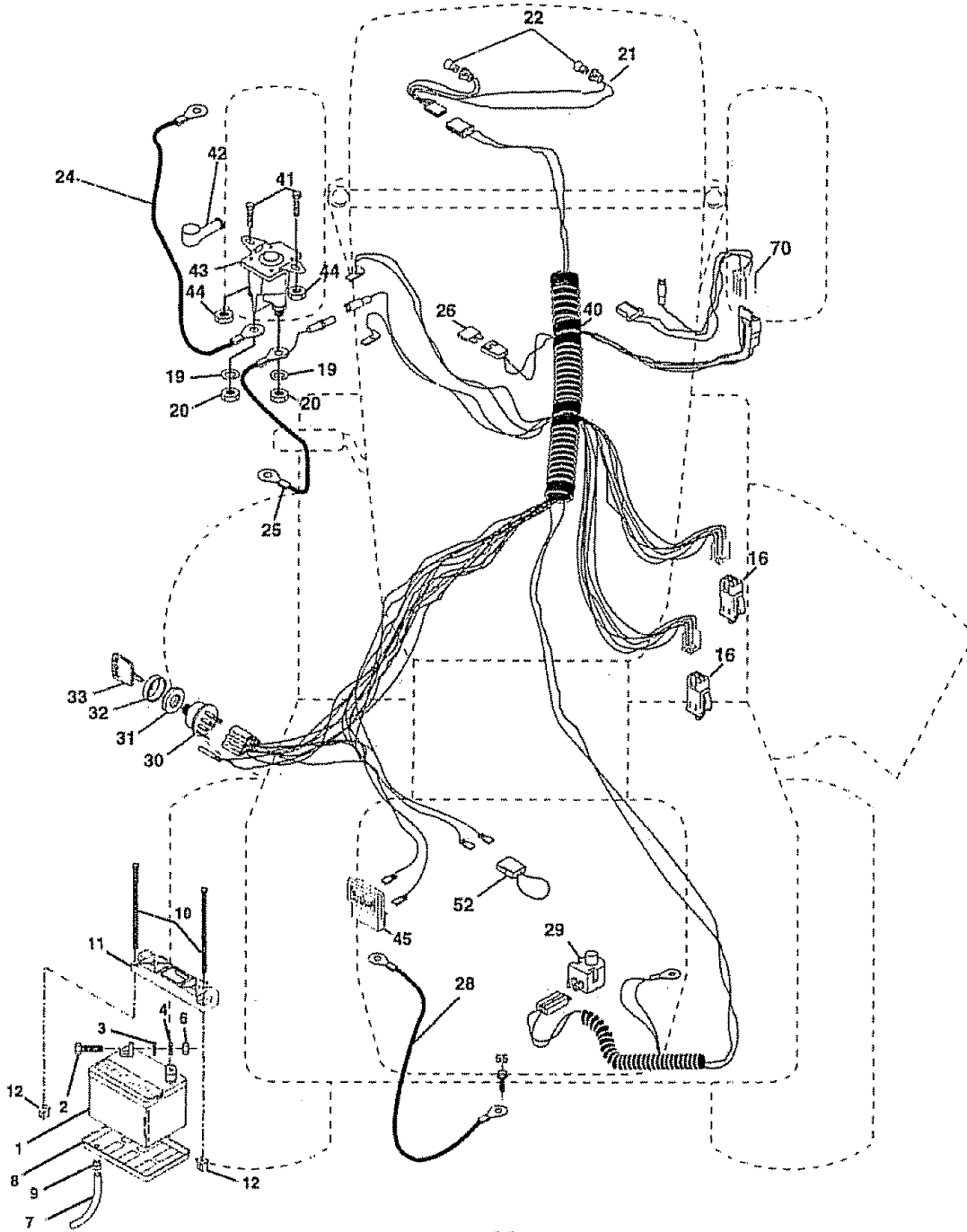

# REPAIR PARTS

TRACTOR - - MODEL NUMBER 917.258670

## ELECTRICAL

KEY NO.	PART NO.	DESCRIPTION
1	144926	Battery
2	74760412	Bolt, Hex 1/4-20 x 3/4
3	STD551025	Washer 9/32 x 5/8 x 16 Gauge
4	STD551125	Washer, Lock 1/4
6	STD541025	Nut, Hex 1/4-20
7	7697J	Tube
8	7603J	Tray, Battery
9	109596X	Clamp, Hose
10	145211	Bolt, Bir Front 1/4-20 x 7-1/2
11	150109	Holddown Battery Front Mount
12	145769	Nut, Push Nylon Battery Front 1/4
16	153664	Switch Interlock Push-In
19	STD551125	Washer, Lock 1/4
20	73350400	Nut, Hex, Jam 1/4-20
21	147430	Harness, Light Socket (w/4152J)
22	4152J	Light Bulb
24	4799J	Cable, Battery
25	14614B	Cable, Battery
26	108824X	Fuse
28	145491	Cable, Ground
29	121305X	Switch, Seat
30	140301	Switch, Ignition 4 Position
31	124211X	Nut, Ignition
32	141226	Cover, Ignition Switch
33	109310X	Key, Molded, Craftsman
40	156442	Harness, Ignition
41	71110408	Bolt Blk Fin Hex 1/4-20 UNC x 1/2
42	131563	Cover, Terminal
43	145673	Solenoid
44	73640400	Nut Keps Blk Hex 1/4-20 UNC
45	121433X	Ammeter Rectangular 6 Amp
52	141940	Protection Wire Loop (Hour Meter)
55	17490508	Screw Thdrol 5/16-18 x 1/2
70	140413	Harness Engine B&S/Tec Dual

NOTE: All component dimensions given in U.S. inches  
1 inch = 25.4 mm

# REPAIR PARTS

TRACTOR - - MODEL NUMBER 917.258670

## CHASSIS AND ENCLOSURES

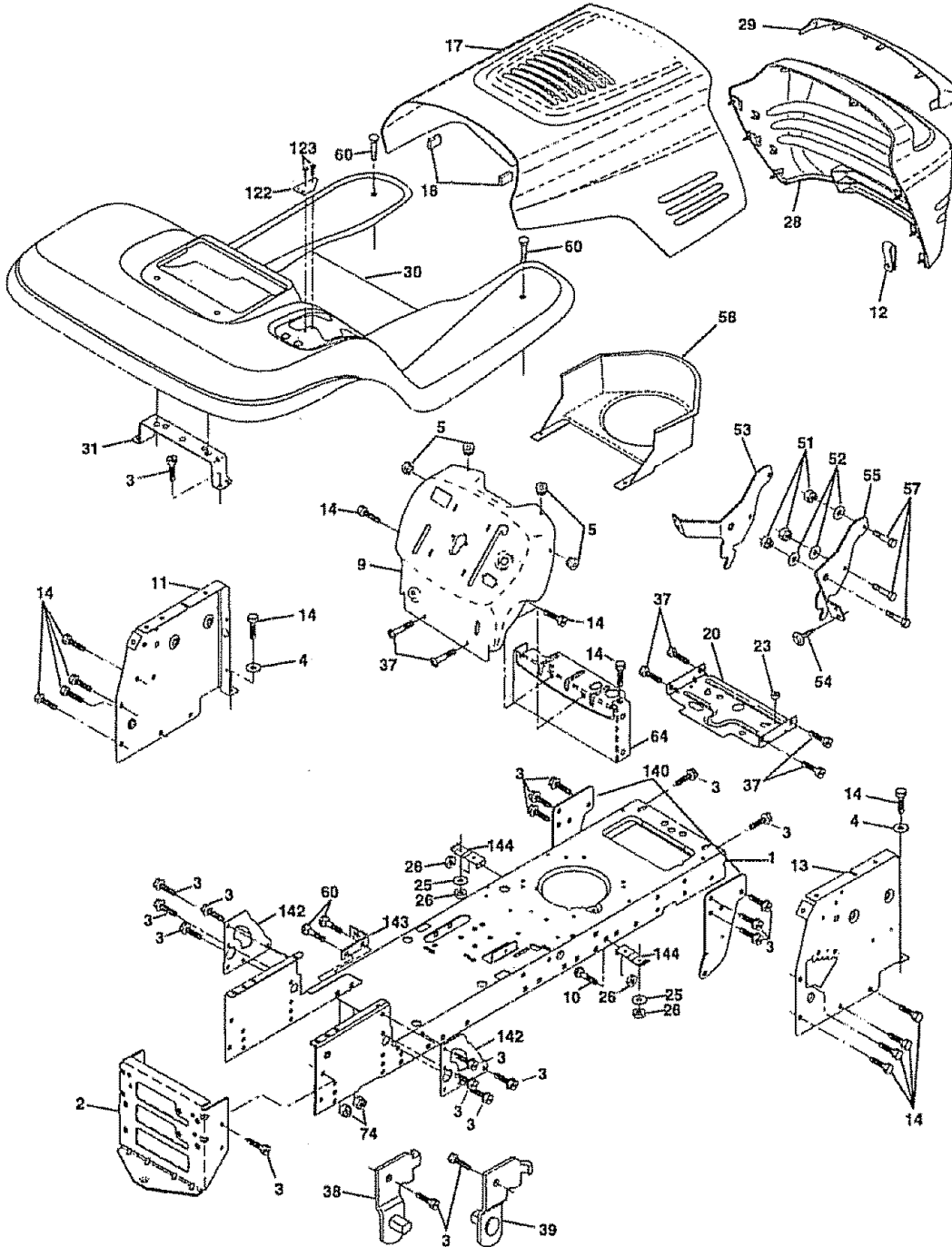

# REPAIR PARTS

## TRACTOR - - MODEL NUMBER 917.258670

### CHASSIS AND ENCLOSURES

KEY NO.	PART NO.	DESCRIPTION
1	153871	Chassis
2	140356	Drawbar
3	17490612	Screw, Thd., Roll. 3/8-16 x 3/4 Type TT
4	STD551025	Washer 13/32 x 3/4 x 16 Gauge
5	155272	Bumper Hood/Dash
9	150156X011	Dash, Silkscreened
10	STD533710	Bolt, Carriage 3/8-16 x 1
11	155927	Panel, Dash, LH
12	145660	Clip Tinnerman Grille P/L
13	155936	Panel, Dash, RH
14	17490608	Screw, Thd., Roll. 3/8-16 x 1/2 Type TT
17	144983X558	Hood Assembly
18	126938X	Bumper Hood
20	156437	Plate Mtg Battery Fuel Tank
23	124028X	Bushing, Snap, Nylon, Fuel Line
25	19131312	Washer 13/32 x 13/16 x 12 Gauge
26	STD541437	Locknut, Hex, with Insert 3/8-16 UNC
28	145198X558	Grille, W/Clips MS-558
29	145200	Lens, Grille
30	151287X558	Fender/Footrest
31	139976	Bracket, Fender/Support
37	17490508	Screw, Thdrol 5/16-18 x 1/2 TYT
38	139886	Pivot Bracket Assembly, LH, Mower, Rear
39	139887	Pivot Bracket Assembly, RH, Mower, Rear
51	73800400	Nut Lock W/Insert 1/4 - 20 UNC
52	19091416	Washer 9/32 X 7/8 X 16 Ga.
53	145201	Bracket Grille Pickoff LH
54	17030814	Screw, Hex Head, Spiderlock #8 x 7/8 AB
55	145202	Bracket Grille Pickoff RH
57	STD552507	Bolt FinHex 1/4 -20 UNC X.75
58	140547	Air Duct P/L 18HP B&S Opp. Twin
60	72140606	Bolt Rdhd Sqnk 3/8-16 UNC x 3/4
64	154798	Dash Lower STLT
74	STD541437	Nut Crownlock 3/8-16 UNC
122	157301	Bracket, Shift STLT
123	152927	Screw TT #10-32 . 5 . 3/8 Flange
140	158418	Bracket Suspension Front
142	156095	Plate Reinforcement STLT
143	154966	Backrest Swaybar Chassis
144	154207	Bracket Footrest STLT

NOTE: All component dimensions given in U.S. inches  
1 inch = 25.4 mm

# REPAIR PARTS

TRACTOR - - MODEL NUMBER 917.258670

## DRIVE

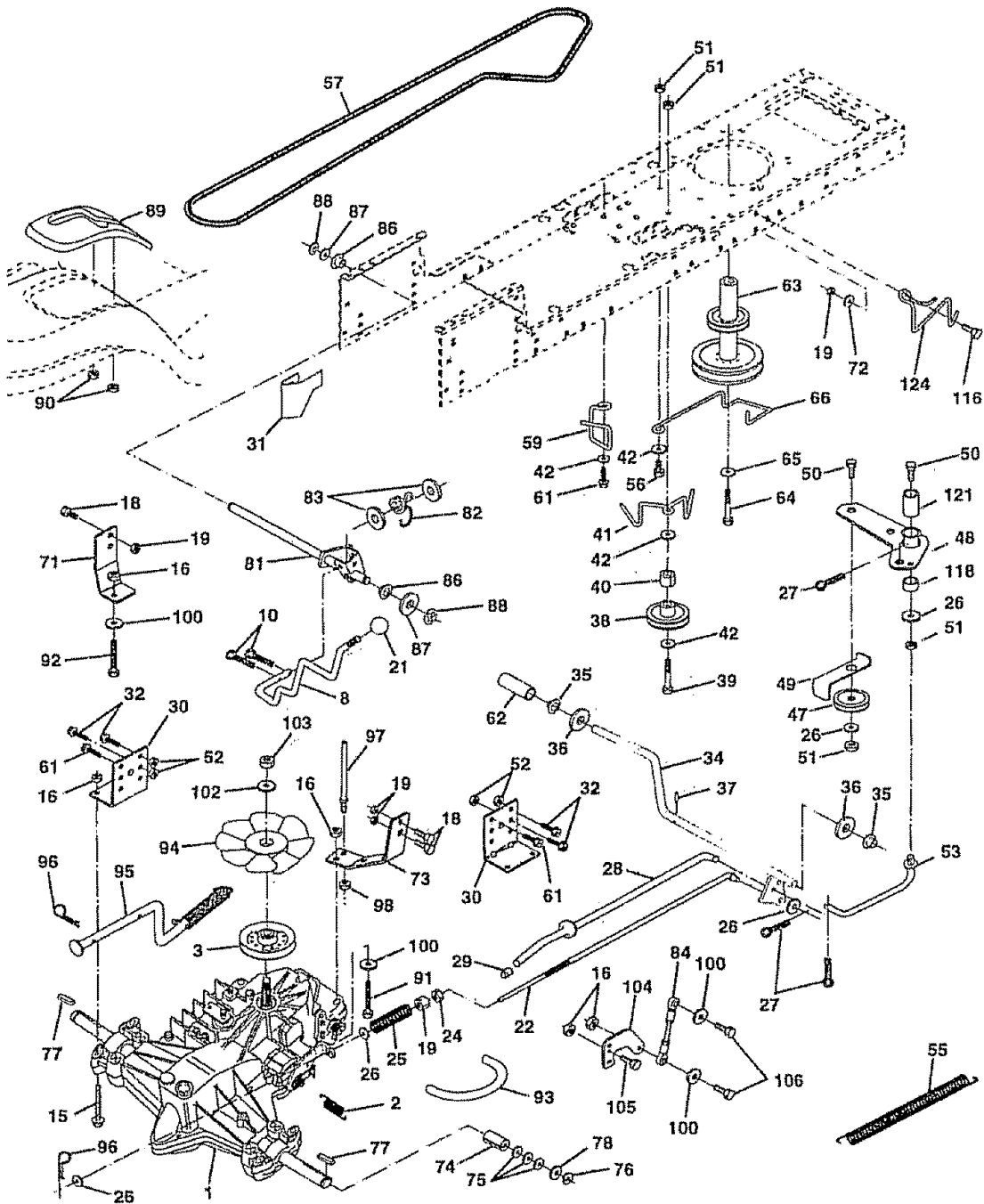

# REPAIR PARTS

TRACTOR - - MODEL NUMBER 917.258670

## DRIVE

KEY NO.	PART NO.	DESCRIPTION	KEY NO.	PART NO.	DESCRIPTION
1	150071	Transaxle ( See Breakdown)	62	8883R	Cover, Pedal
		Hydro Gear Model No. 310-0650	63	140186	Pulley, Engine
2	142431	Spring, Return, Brake	64	71170764	Bolt Hex 7/16-20 x 4 Gr. 5
3	143995	Pulley, Transaxle	65	STD551143	Washer
8	154792	Rod Shift Fender STLT	66	154778	Keeper Belt Engine Full-Proof
10	STD561210	Pin Cotter 1/8 x 1 CAD	71	140158	Strap Torque Lh Hydro 18/20" T
15	74490544	Bolt Hex Fighd 5/16-18 Gr. 5	72	19132012	Washer 13/32 x 1-1/4 x 12 Ga.
16	STD541431	Nut Lock Hex W/Ins. 5/16-18 Unc	73	156347	Strap Torque Rh Hydro 0650
18	STD523710	Bolt Fin Hex 3/8-16 Unc x 1 Gr. 5	74	121199X	Spacer, Split
19	STD541437	Nut Lock Hex W/Wsh 3/8-16 Unc	75	121749X	Washer 25/32 x 1-1/4 x 16 Gauge
21	130564	Knob, Deluxe 1/2-13	76	STD581075	E-Ring
22	145627	Rod, Brake Hydro	77	123583X	Key, Square
24	73350600	Nut, Hex Jam 3/8-16 Unc	78	121748X	Washer 25/32 x 1-5/8 x 16 Gauge
25	106888X	Spring, Brake Rod	81	156046	Shaft Asm. Cross Hydro 20" Tires
26	STD551037	Washer	82	123782X	Spring Torsion T/A
27	STD561210	Pin Cotter 1/8 x 3/4 CAD.	83	19171216	Washer 17/32 x 3/4 x 16 Ga.
28	145204	Rod, Parking Brake	84	140548	Rod, Tie Hydro 20" Tires
29	124236X	Cap, Parking Brake	86	71208	Bushing Rod Strig 629/632 ID
30	130807	Bracket, Transaxle	87	19212016	Washer 21/32 x 1-1/4 x 16 Ga.
31	127275X	Keeper Belt Lh	88	12000008	Ring Klip #5304-62
32	74760512	Bolt Hex Hd 5/16-18 Unc x 3/4	89	154882	Console, Shift
34	155071	Shaft, Foot Pedal	90	124346X	Nut Self-Thd Wsh-hd 1/4 Zinc
35	120183X	Bearing, Nylon	91	74780536	Bolt Fin Hex 5/16-18 x 2-1/4
36	19211616	Washer	92	74780524	Bolt Fin Hex 5/6-18 Unc x 1-1/2
37	1572H	Pin, Roll	93	142564	Line Fuel Hydro 4"
38	123674X	Pulley, Idler, Flat	94	140462	Fan, Hydro 7"
39	STD523727	Bolt	95	144643	Control Bypass Hydro 20" Tires
40	4470J	Spacer, Split	96	4497H	Retainer Spring 1" Zinc/Cad
41	154777	Keeper, Belt Idler	97	140469	Keeper Bolt Rh Hydro 0750 18/20"
42	19131312	Washer 13/32 x 13/16 x 12 Gauge	98	73510600	Nut Keps Hex 3/8-16 Unc
47	127783	Pulley, Idler, V-Groove	100	19111216	Washer 11/32 x 3/4 x 16 Ga.
48	154604	Bellcrank Assembly	102	141322	Washer Bellville .501D x 1.50D
49	123205X	Retainer, Belt	103	73940800	Nut Hex Jam Toplock 1/4-20 Unf
50	STD523715	Bolt	104	140156	Arm, Control Hydro
51	STD541437	Nut Crownlock 3/8-16 UNC	105	71070516	Screw Cap Hex 5/16 x 18 x 1
52	STD541431	Nut, Crownlock 5/16-18 Unc	106	74780520	Bolt Fin Hex 5/16-18 Unc x 1-1/4
53	105710X	Link, Clutch	116	72110610	Bolt Carr. 3/8-16 x 1.25
55	105709X	Spring, Return, Clutch	118	154774	Spacer Bellcrank
56	STD523712	Bolt Hex 3/8-16 x 1-1/4	121	154419	Myliner Clutching STL
57	140294	V-Belt, Ground Drive	124	156470	Guide Belt RH Engine
59	140312	Keeper, Center Span			
61	17490612	Screw Thdrol. 3/8-16 x 3/4 Ty. TT			

NOTE: All component dimensions given in U.S. inches  
1 inch = 25.4 mm



# REPAIR PARTS

TRACTOR - - MODEL NUMBER 917.258670

## STEERING ASSEMBLY

KEY NO.	PART NO.	DESCRIPTION
1	139768	Wheel Steering Std Black
2	154427	Axle Asm Front
3	154422	Spindle Asm Lh
4	154423	Spindle Asm Rh
5	6266H	Bearing Race Thrust Harden
6	121748X	Washer 25/32 X 1 5/8 X 16ga
7	19272016	Washer 27/32 X 1 1/4 X 16 Ga
8	12000029	Ring Klip #15304-75
9	3366R	Bearing Col Strg Blk
10	156438	Link Drag Extended Stamped
11	STD551137	Washer Lock Hvy Hlcl Spr 3/8
13	154779	Bearing Axle STLT/GT
15	73901000	Locknut Flange 5/8-11 UNC
17	156546	Shaft Asm Strg Private Label
18	57079	Washer Thrust 515x 750x 033
19	124035X	Support Shaft
20	126684X	Washer Shim 1/4 X 5/8 X .062
21	STD551125	Washer Lock Hvy Helical 1/4
22	71100410	Screw Cap Sckt Hd Phos & Oil
23	127501	Shaft Asm Pittman
25	154406	Bracket Steering
26	126847X	Bushing Rod Tie Blk Lt
27	136874	Gear Sector
28	19131416	Washer 13/32 X 7/8 X 16ga
29	17490612	Screw Thdrol 3/8-16x3/4 Ty-It
30	STD561210	Pin Cotter 1/8 X 3/4 Cad
32	130465	Rod Tie Wire Form 19 75 Mech
36	155099	Bushing Strg 5/8 Id Dash
37	152927	Screw TT #10-32x5x3/8 Flange
38	139769	Insert Cap Strg Wheel Std Blk
39	19133808	Washer 13/32 X 2-3/8 X 8 Ga
40	7810H	Nut Lock Center 3/8-24 UNF
41	100711L	Adaptor Wheel Strg
42	145054	Boot Shaft Steering
43	121749X	Washer 25/32 X 1 1/4 X 16 Ga
44	153720	Extension Steering Non-Adjust
46	121232X	Cap Spindle Fr Top Blk
47	6855M	Fitting Grease
51	73800500	Nut Lock Hex W/Ins 5/16 -18 UNC
54	74780520	Bolt Fin Hex 5/16 - 18 UNC X 1 -1/4
62	156594	Kit, Steering Assembly
63	74780616	Bolt Fin Hex 3/8-16unc x 1 Gr.5
65	154780	Spacer Axle
66	154404	Bearing Arm Pittman
67	74781044	Bolt Fin Hex 5/8-11 UNC x 2-3/4
68	154429	Axle Brace

NOTE: All component dimensions given in U.S. inches  
1 Inch = 25.4 mm

# REPAIR PARTS

TRACTOR - - MODEL NUMBER 917.258670

## ENGINE

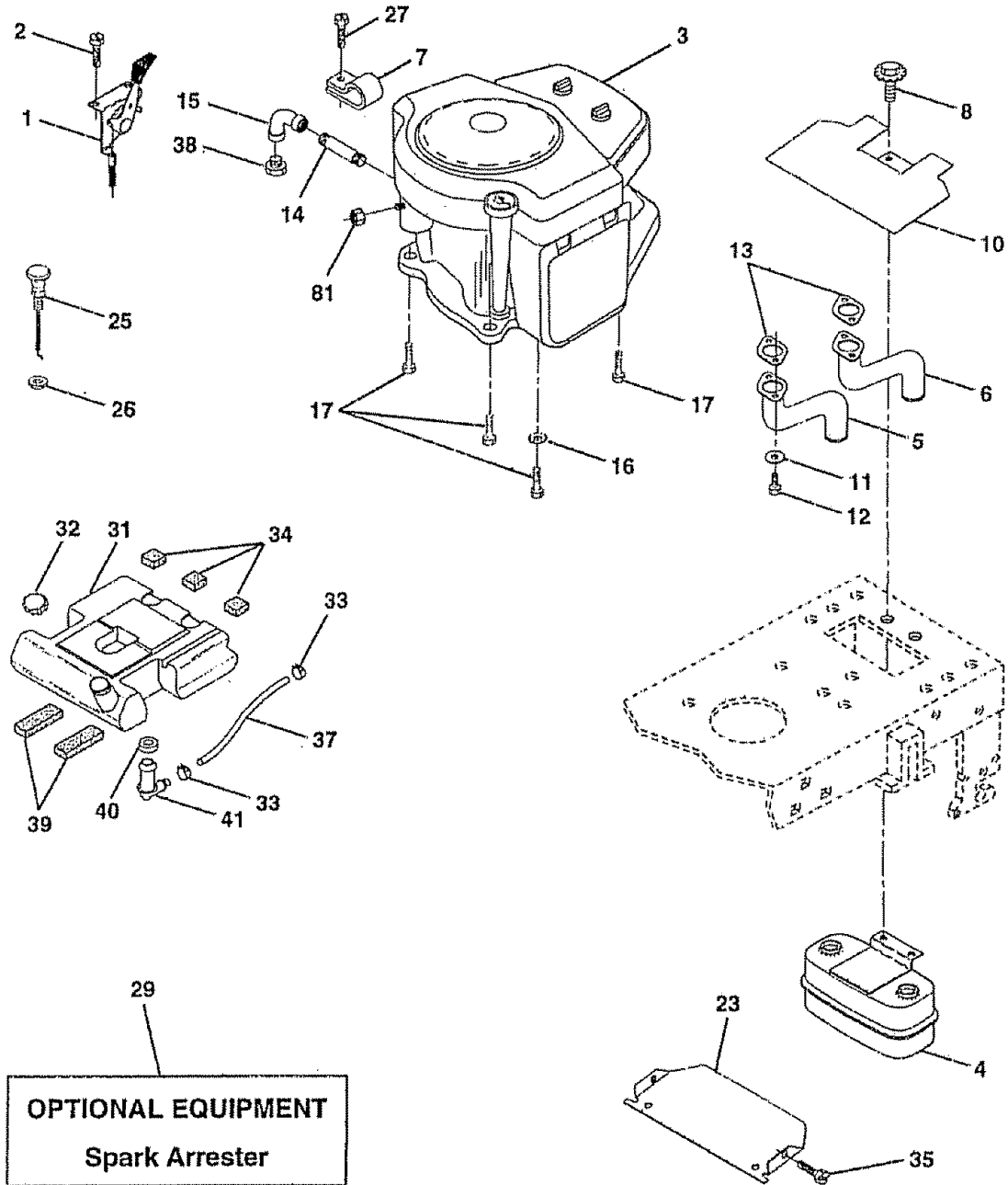

# REPAIR PARTS

TRACTOR - - MODEL NUMBER 917.258670

## ENGINE

KEY NO.	PART NO.	DESCRIPTION
1	151273	Control Throt Paddle 32 22
2	17720410	Screw Hex Thd Cut 1/4-20x5/8 T
3	-----	Engine (See Breakdown) Briggs Model No. 42E707-1631-01
4	149723	Muffler Exhaust
5	144069	Exhaust Asm. Left
6	144068	Exhaust Asm. Right
7	138129	Clamp Tube Double Engine
8	150176	Bolt 5/16 - 18 UNC X 3/4 W/Sems
10	145552	Heat Shield Lt
11	STD551125	Washer Lock Hvy. Helical 1/4
12	STD522507	Bolt Fin Hex 1/4-20 x 3/4
13	272250	Gasket Muffler
14	13280336	Nipple Pipe 4-1/2"
15	13200300	Elbow Std 90 Degree 3/8-18 Npt
16	STD551237	Washer Lock Ext Tooth 3/8
17	17490624	Screw Thdrol 3/8-16x1-1/2 Tytt
23	156123	Shield Browning
25	145996	Control Choke
26	73920600	Nut Keps 3/8-24 Unf
27	152927	Screw TT #10-32 x 5 x 3/8 Flange
29	137180	Arrestor Spark
31	153630	Tank Fuel 3 50 Rear
32	155971	Cap Fuel Guage STL.T
33	123487X	Clamp Hose Blk
34	106082X	Spacer Pad
35	17490512	Screw Thdrol 5/16-18 x 3/4 TYT
37	8543R	Line Fuel
38	-----	Plug Oil Drain (Order From Engine Manufacturer)
39	109227X	Pad Idler 1.75 x .75 x .06
40	3645J	Bushing
41	139277	Stem Tank Fuel
81	128861	Nut, Flange 1/4-20 Starter Nut

**NOTE:** All component dimensions given in U.S. Inches  
1 inch = 25.4 mm

# REPAIR PARTS

TRACTOR - - MODEL NUMBER 917.258670

## MOWER LIFT

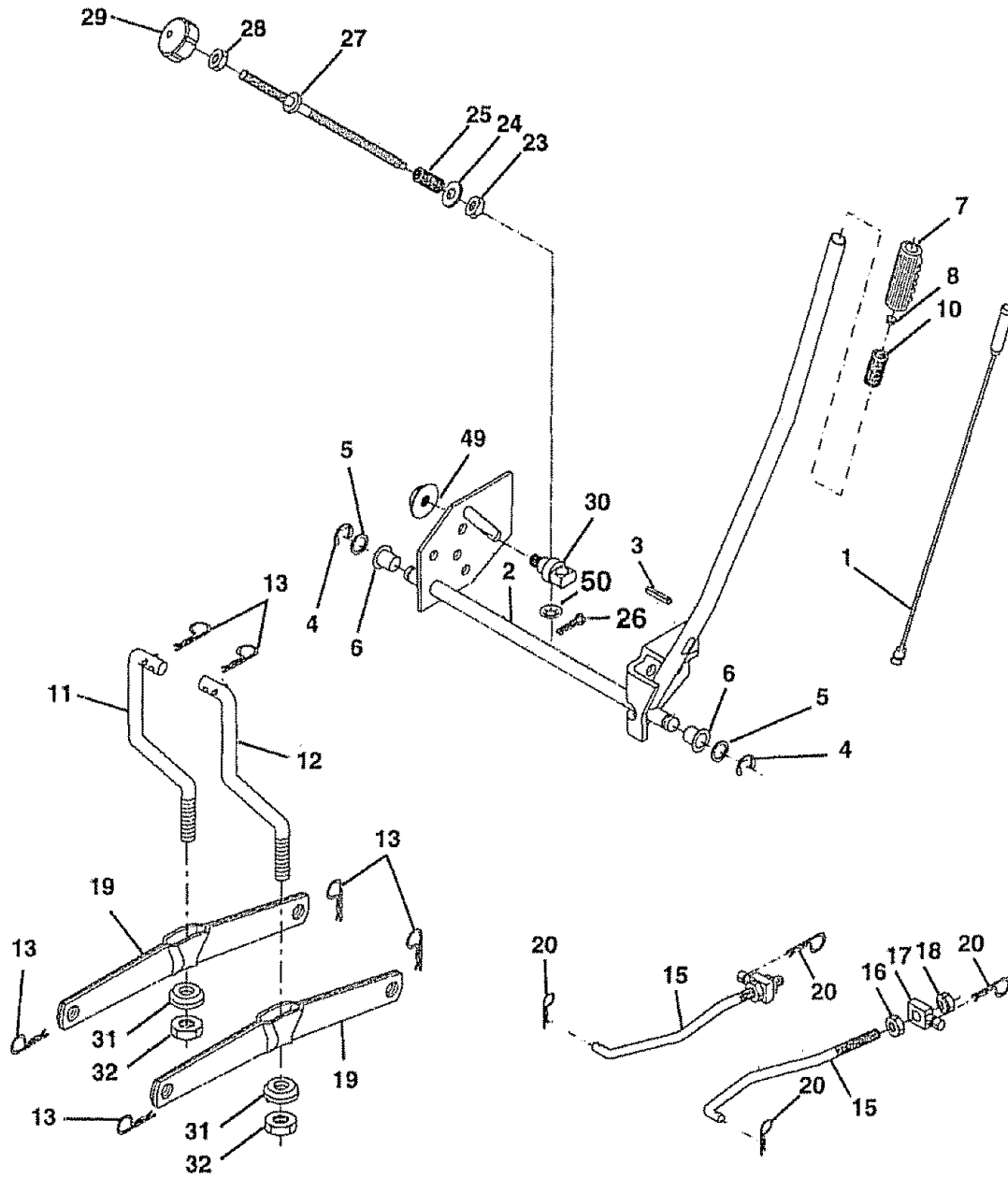

# REPAIR PARTS

TRACTOR - - MODEL NUMBER 917.258670

## MOWER LIFT

KEY NO.	PART NO.	DESCRIPTION
1	136973	Wire Assy., Inner, with Plunger
2	145117	Shaft Asm. Lift
3	105767X	Pin Groove
4	12000002	E Ring #5133-62
5	19211621	Washer 21/32 x 1 x 21 Ga.
6	120183X	Bearing Nylon
7	125631X	Grip Handle Fluted
8	122365X	Button Plunger Read
10	122512X	Spring Cprsn
11	139865	Link Lift Lh Fixed Length
12	139866	Link Lift Rh Fixed Length
13	STD624008	Retainer Spring
15	127218	Link Front
16	73350800	Nut Jam Hex 1/2-13 Unc
17	130171	Trunnion Blk Zinc
18	73800800	Nut Lock W/Wsh 1/2-13 Unc
19	139868	Arm Suspension Rear
20	STD624008	Retainer Spring
23	110807X	Nut Spring
24	19131016	Washer 13/32 x 5/8 x 16 Ga.
25	2876H	Spring 2-1/8"
26	76020308	Pin cotter 3/32 x 1/2
27	126971X	Rod Adj. Lift
28	73350600	Nut Hex Jam 3/8-16
29	138057	Knob Inf. 3/8-16
30	150233	Trunnion Infin. Height
31	140302	Bearing, Pivot, Lift, Special
32	73540600	Nut, Crownlock 3/8-24
49	145212	Nut Flange Lock

NOTE: All component dimensions given in U.S. inches  
1 inch = 25.4 mm

# REPAIR PARTS

TRACTOR -- MODEL NUMBER 917.258670

## MOWER DECK

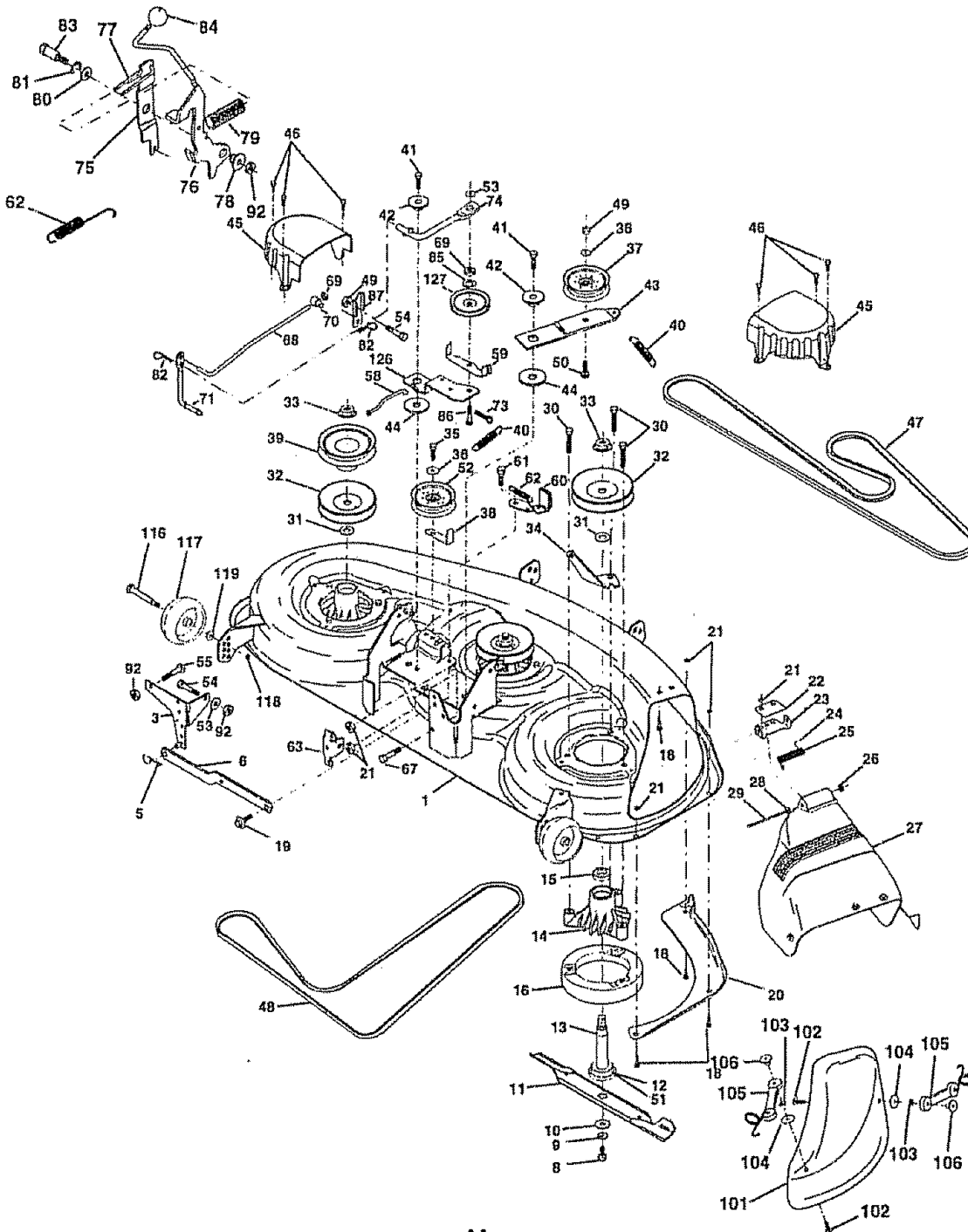

# REPAIR PARTS

## TRACTOR - - MODEL NUMBER 917.258670

### MOWER DECK

KEY NO.	PART NO.	DESCRIPTION	KEY NO.	PART NO.	DESCRIPTION
1	156948	Deck Asm., Mower 46"	52	156493	Pulley, Idler, 97 46 Prf. Drive
3	138457	Bracket Asm., Sway Bar	53	19131312	Washer, 13/32 x 13/16 x 12 Ga.
5	4939M	Retainer Spring	54	74780616	Bolt, Fin. Hex 3/8-16 x 1 Gr. 5
6	130832	Arm, Suspension, Rear (Sway Bar)	55	72140608	Bolt, RDHD Sqnk. 3/8-16 UNC x 1
8	850857	Bolt, Patched 3/8-24 x 1-1/4 Gr. 8	58	156488	Link, Brake 46" Mech
9	10030600	Washer, Lock Hvy., Unplated 3/8	59	157034	Guide, Belt 46" Mower
10	140296	Washer, Hard Blade, Mower Vented	60	156722	Arm Asm. Brake 46"
11	152443	Blade, 46" Mower Deck	61	139888	Bolt, Shoulder 5/16-18 Type TT
12	129695	Bearing, Ball, Mandrel #6204	62	131870	Spring Return
13	137553	Shaft Asm. w/Lower Bearing (Includes Key No. 12)	63	156473	Bracket, Clutch Rod Pivot
14	137152	Housing, Mandrel	67	74760512	Bolt, Hex Head 5/16-18 x 3/4
15	110485X	Bearing, Ball, Mandrel	68	156487	Rod, Clutch
16	140329	Stripper, Mower Round	69	73350600	Nut, Hex Jam 3/8-16 UNC
18	72140505	Bolt, Carriage 5/16-18 x 5/8	70	142028	Trunnion, Adj. 94
19	132827	Bolt, Hex Head, Shoulder 5/16-18	71	133551	Rod, Pivot with Nibs
20	145055	Baffle, Vortex Mower 46"	72	19111116	Washer 11/32 x 11/16 x 16 Ga.
21	73680500	Nut, Crownlock 5/16-18 UNC	73	76020412	Pin, Cotter 1/8 x 3/4
22	134753	Stiffener, Bracket	74	156474	Link, Clutch 46" Mech.
23	131267	Bracket, Deflector	75	127847	Arm, Clutch Secondary
24	105304X	Cap, Sleeve	76	154809	Lever, Asm. Clutch Primary
25	123713X	Spring, Torsion, Deflector	77	127845	Keeper, Spring
26	110452X	Nut, Push	78	127498	Bushing, .747 OD. x .794 ID.
27	157788	Shield, Deflector Mower	79	153701	Spring, Mower Clutch
28	19111016	Washer 11/32 x 5/8 x 16 Ga.	80	121748X	Washer 25/32 x 1-5/8 x 16 Ga.
29	131491	Rod, Hinge	81	12000029	Ring, Clip
30	138776	Screw, Hex Head, Thdroll	82	4497H	Retainer Spring 1"
31	129963	Washer, Spacer Mower Vented	83	129803	Bolt, Shoulder 3/8-16 Unc
32	153531	Pulley, Mandrel	84	149846	Knob, Custom Oval
33	137266	Nut, Fig. Top Lock Cntr. 9/16	87	156373	Bracket, Extension
34	144945	Anchor, Spring Deck 46"	92	73800600	Locknut, Hex, w/Insert 3/8-16 UNC
35	17490628	Screw, Thdroll 3/8-16 x 1-3/4 Tytt	94	149846	Knob Custom Oval
36	19131316	Washer 13/32 x 13/16 x 16 Ga.	101	145579	Cover, Mulching
37	131494	Pulley, Idler, Flat	102	71161010	Screw
38	156086	Keeper, Belt, Idler	103	10071000	Washer, Lock #10
39	144917	Pulley, Idler, Driven	104	19061216	Washer
40	137273	Spring, Secondary 44/46/50 Vent	105	130758	Latch Asm. Bagger
41	17490620	Screw, Thdroll 3/8-16 x 1-1/4 Tytt	106	2029J	Nut, Weld
42	122052X	Spacer, Retainer	116	137644	Bolt, Shoulder
43	144949	Arm, Idler Secondary	117	133957	Gauge Wheel, Wide
44	133943	Washer, Hardened	118	73930600	Nut, Centerlock 3/8-16 UNC
45	145059	Cover, Mandrel Deck	119	19121414	Washer 3/8 x 7/8 x 14 Ga.
46	137729	Screw, Thdroll. 1/4-20 x 5/8	126	156472	Arm, Idler, Deck 46" Mech.
47	144959	V-Belt, Mower, Secondary	127	146763	Pulley, Idler, V-Groove Dim. 4.25
48	139573	V-Belt, Mower, Primary	---	157112	Deck Complete (Std. Deck-Order separately mulcher plate and gauge wheel components Key Nos. 101-106 and 116-118)
49	73680600	Nut, Crownlock 3/8-16 UNC	---	143651	Mandrel Asm. Service
50	72110612	Bolt, Carriage 3/8-16 x 1-1/2 Gr. 5	NOTE: All component dimensions given in U.S. inches		
51	153390	Washer, Felt	1 inch = 25.4 mm		

# REPAIR PARTS

TRACTOR - - MODEL NUMBER 917.258670

## SEAT ASSEMBLY

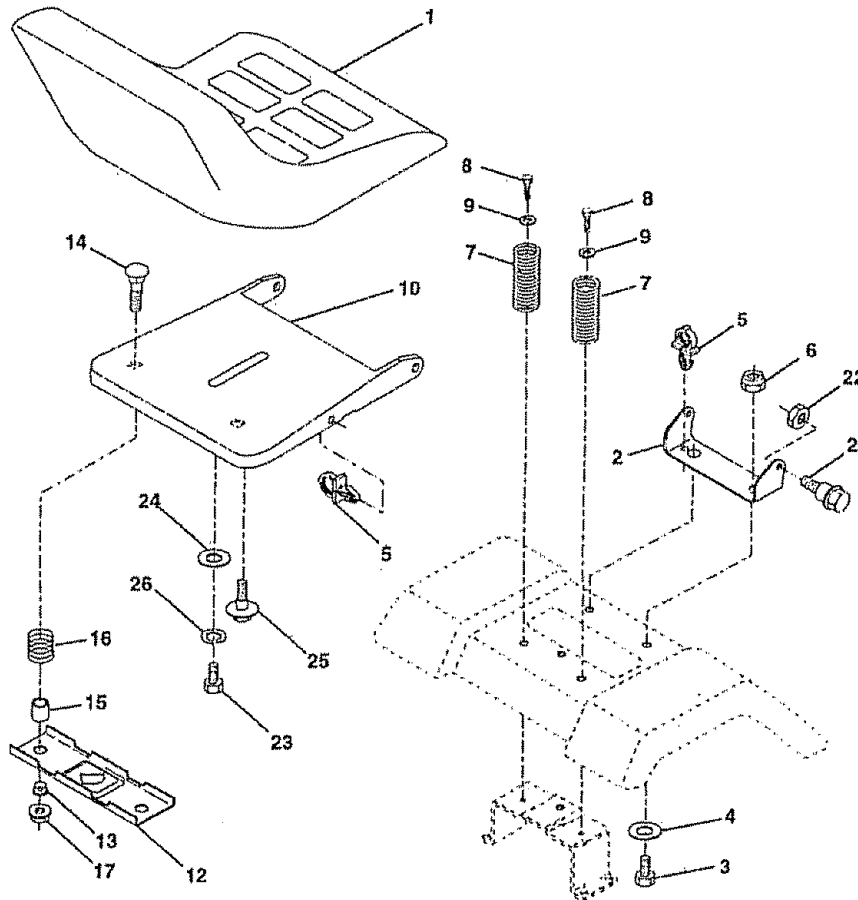

KEY NO.	PART NO.	DESCRIPTION	KEY NO.	PART NO.	DESCRIPTION
1	140123	Seat	13	121248X	Bushing Snap Blk Nyl 50 Id
2	140551	Bracket Pnt Pivot Seat (blk )	14	72050411	Bolt Rdhd Sht Nk 1/4-20x1-3/8
3	74760616	Bolt Fin Hex 3/8-16 UNC x 1	15	134300	Spacer Split 28 X 96 Zinc
4	19131610	Washer Flat 13/32 x 1 x 10 Ga	16	121250X	Spring Cprsn 1 27 Blk Pnt
5	145006	Clip Push-In	17	123976X	Nut Lock 1/4 Lge Fig Gr 5 Zinc
6	STD541437	Nut Lock Hex W/Ins 3/8 -16 UNC	21	153236	Bolt Shoulder 5/16-18 Unc
7	124181X	Spring Seat Cprsn 2 250 Blk Zi	22	STD541431	Nut Lock Hex W/Ins 5/16-18
8	17490616	Screw 3/8-16x1	23	74780814	Bolt Fin Hex 1/2-13 X 7/8 Gr 5
9	19131614	Washer 13/32 x 1 x 14 Ga	24	19171912	Washer 17/32 X 1-3/16 X 12 Ga
10	155925	Pan Pnt Seat (blk )	25	127018X	Bolt Shoulder 5/16-18 X 62
12	121246X	Bracket Pnt Mounting Switch	26	STD551150	Washer Lock Hvy Hlcl Spr 1/2

**NOTE:** All component dimensions given in U.S. Inches  
1 inch = 25.4 mm

# REPAIR PARTS

## TRACTOR - - MODEL NUMBER 917.258670

### DECALS

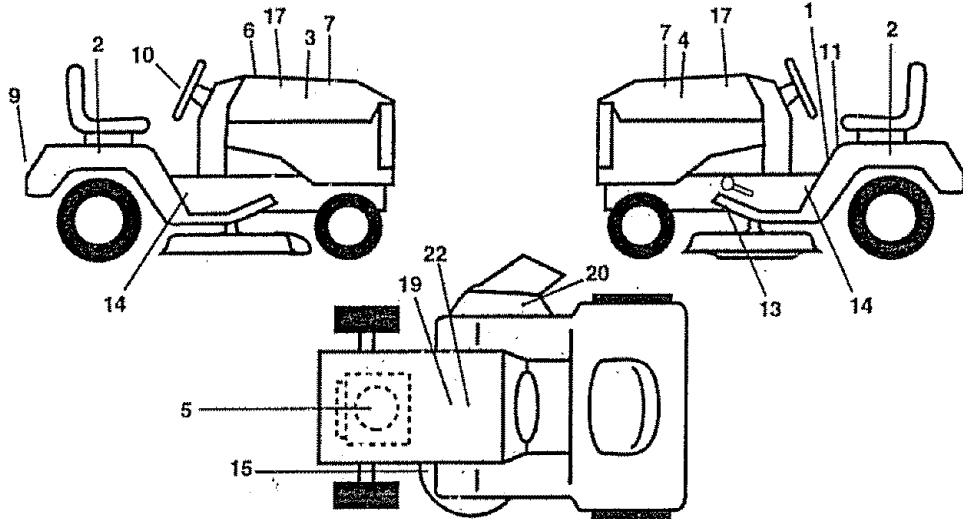

KEY NO.	PART NO.	DESCRIPTION
1	156439	Decal Fender Danger Sears
2	156810	Decal Fend Auto Sears Gold
3	151299	Decal Hood Rh Craftsman
4	151300	Decal Hood Lh Craftsman
5	273503	Decal HP Engine
6	133644	Decal Maint Customer Sears Dom
7	150927	Decal Panel Side B&S5
9	146709	Decal Fender Craftsman Gold
10	150333	Decal, Cap CNSMR Help Line SRS
11	156811	Decal Fender STLTH Oper Inst E/S
13	146046	Decal V-belt Dr Sch Tractor E
14	151401	Decal Chassis Hydro 46"
15	139346	Decal Mower Drive Schematic

KEY NO.	PART NO.	DESCRIPTION
17	158215	Decal, Insert, Hood
19	138047	Decal, Battery Diehard Sears
20	156787	Decal Deck Mower EZ3 Mulching
22	149516	Decal Battery
--	138311	Decal Lift Handle
--	142341	Decal, Drawbar Cntrl. Mvt. Hyd. Lt.
--	157322	Manual, Owner's (English)
--	157323	Manual, Owner's (Spanish)
--	154515	Pad Footrest Lh STLT
--	154516	Pad Footrest Rh STLT

### WHEELS & TIRES

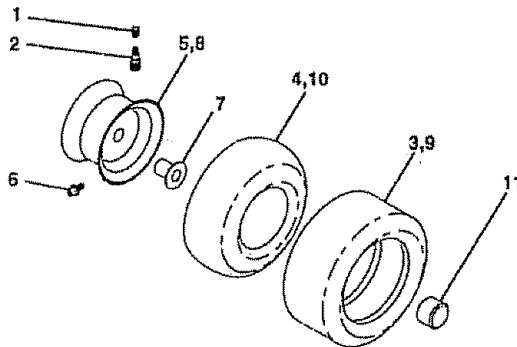

KEY NO.	PART NO.	DESCRIPTION
1	59192	Valve Cap, Tire
2	65139	Stem, Valve
3	106222X	Tire, Front
4	59904	Tube, Front Tire (Not Provided, Service Item Only)
5	106732X427	Rim, Front
6	278H	Fitting, Grease (Front Wheel Only)
7	9040H	Bearing, Flange (Front Wheel Only)
8	106108X427	Rim, Rear
9	122082X	Tire, Rear
10	7152J	Tube, Rear Tire (Not Provided, Service Item Only)
11	104757X	Cap, Axle
--	144334	Sealant, Tire (10 oz. Tube)

NOTE: All component dimensions given in U. S. inches  
1 inch = 25.4 mm

# REPAIR PARTS

TRACTOR - - MODEL NUMBER 917.258670

HYDRO GEAR TRANSAXLE - MODEL NUMBER 310-0650

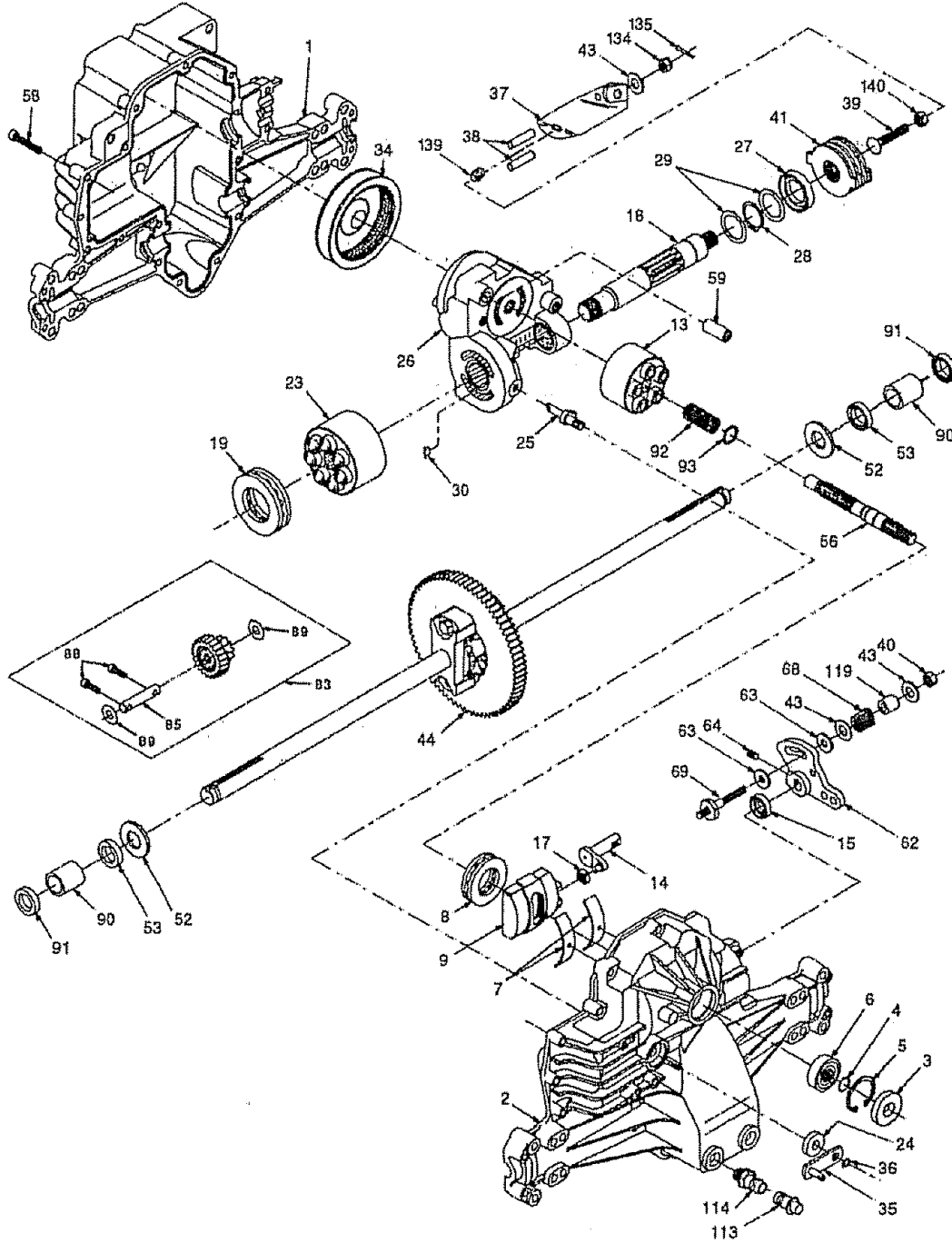

# REPAIR PARTS

TRACTOR - - MODEL NUMBER 917.258670

HYDRO GEAR TRANSAXLE - MODEL NUMBER 310-0650

KEY PART NO. NO.	DESCRIPTION	KEY PART NO. NO.	DESCRIPTION
1 142930	Housing, Lower	43 142884	Washer 7/16 x 7/8 x .060
2 142931	Assembly, Upper Housing	44 150829	Differential Assembly
3 142932	Seal, Lip	52 142991	Washer 3/4 x 1.5 x .13
4 142928	Ring, Wire Retaining	53 142961	Seal .75 x 1.25 x .250
5 142933	Ring, Retaining	56 142963	Shaft, Input
6 142934	Bearing, Shaft Ball	58 142964	Bolt 1/4-20 x 1.38
7 142935	Bearing, Cradle	59 142965	Pin .5 OD x .43 ID x .750
8 150771	Bearing, Thrust 30 x 52 x 13	62 142966	Arm, Control
9 142937	Swashplate, Variable	63 142967	Puck, Dampener
13 142938	Block, Cylinder Assembly	64 142920	Set Screw
14 142939	Arm, Trunnion	68 142969	Spring
15 142940	Seal, Lip	69 144610	Stud 5/16-24
17 142941	Guide, Slot	83 142971	Jackshaft Assembly
18 150772	Shaft, Motor	85 150806	Jackshaft
19 150773	Bearing, Thrust 42 x 68 x 16	88 142973	Screw, Cap
23 142944	Block, Cylinder Assembly	89 142974	Washer 7/16 x 1 x 1/2
24 142945	Seal, Lip 10 x 25 x 7	90 142975	Sleeve Bearing
25 142946	Actuator, Bypass	91 142976	Seal, Wiper
26 150774	Center Section Assembly Kit	92 142977	Spring, Block
27 142948	Seal, Lip 26 x 42 x 8	93 142978	Washer, Block Thrust
28 142949	Ring, Retaining	113 142917	Cap, Vent Assembly
29 142950	Washer 26 x 35 x 1	114 142918	Fitting, O-Ring Assembly
34 142951	Oil Filter Element	119 142980	Spacer
35 142952	Arm, Bypass	134 144607	Nut, Castle 5/16-24
36 142953	Ring, Retaining	135 144608	Pin, Cotter
37 142954	Arm, Actuating	139 150775	Spring, Compression
38 142955	Pin, Actuating	140 150776	Nut, Hex 5/16-24
39 150777	Bolt 5/16-24 x 1-3/4		
40 150778	Locknut, Hex 5/16-24 UNJC		
41 142958	Brake Rotor/Stator Kit		

NOTE: All component dimensions given in U.S. inches  
1 inch = 25.4 mm

# REPAIR PARTS

TRACTOR - - MODEL NUMBER 917.258670

BRIGGS & STRATTON ENGINE - MODEL NUMBER 42E707, TYPE NUMBER 1631-01

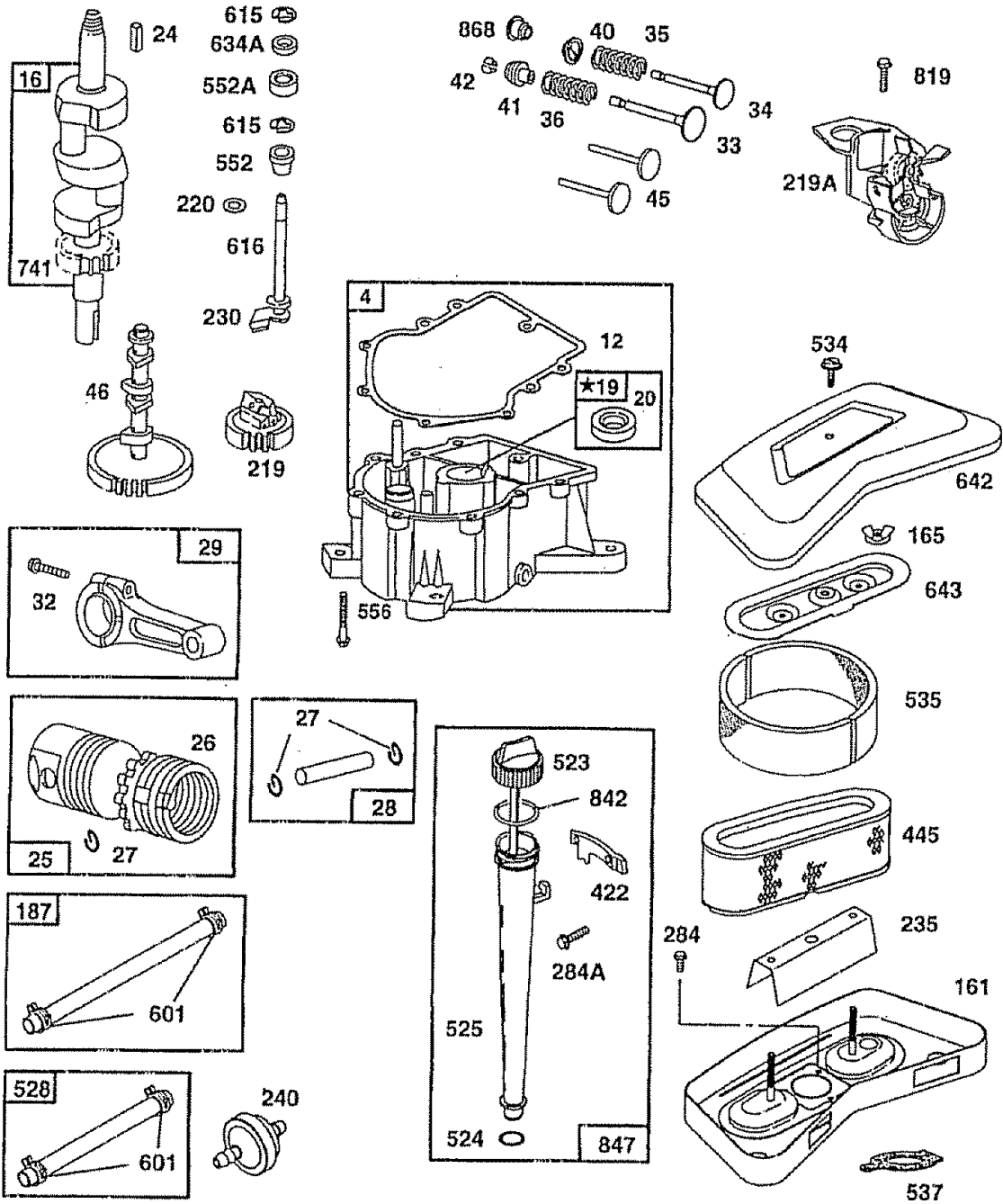

# REPAIR PARTS

TRACTOR - - MODEL NUMBER 917.258670

BRIGGS & STRATTON ENGINE - MODEL NUMBER 42E707, TYPE NUMBER 1631-01

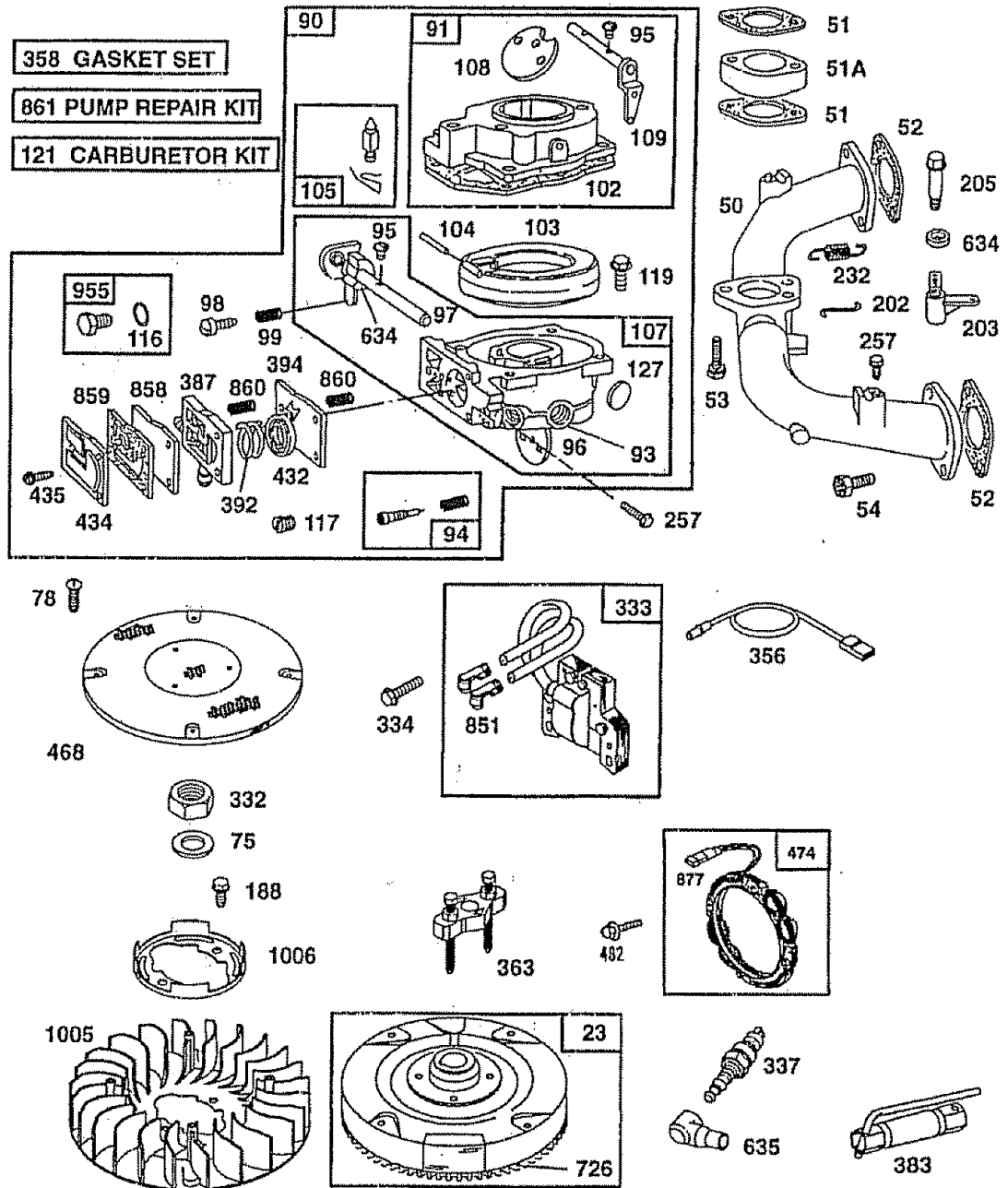

# REPAIR PARTS

TRACTOR - - MODEL NUMBER 917.258670

BRIGGS & STRATTON ENGINE - MODEL NUMBER 42E707, TYPE NUMBER 1631-01

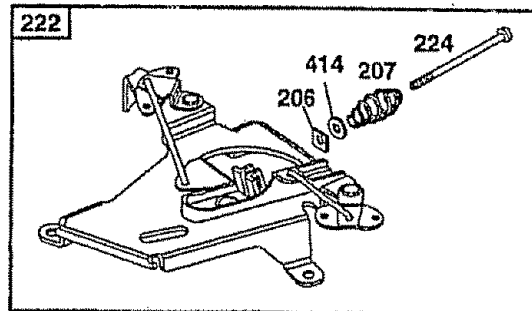
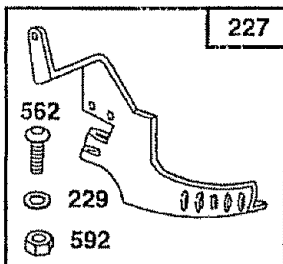
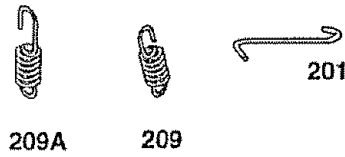
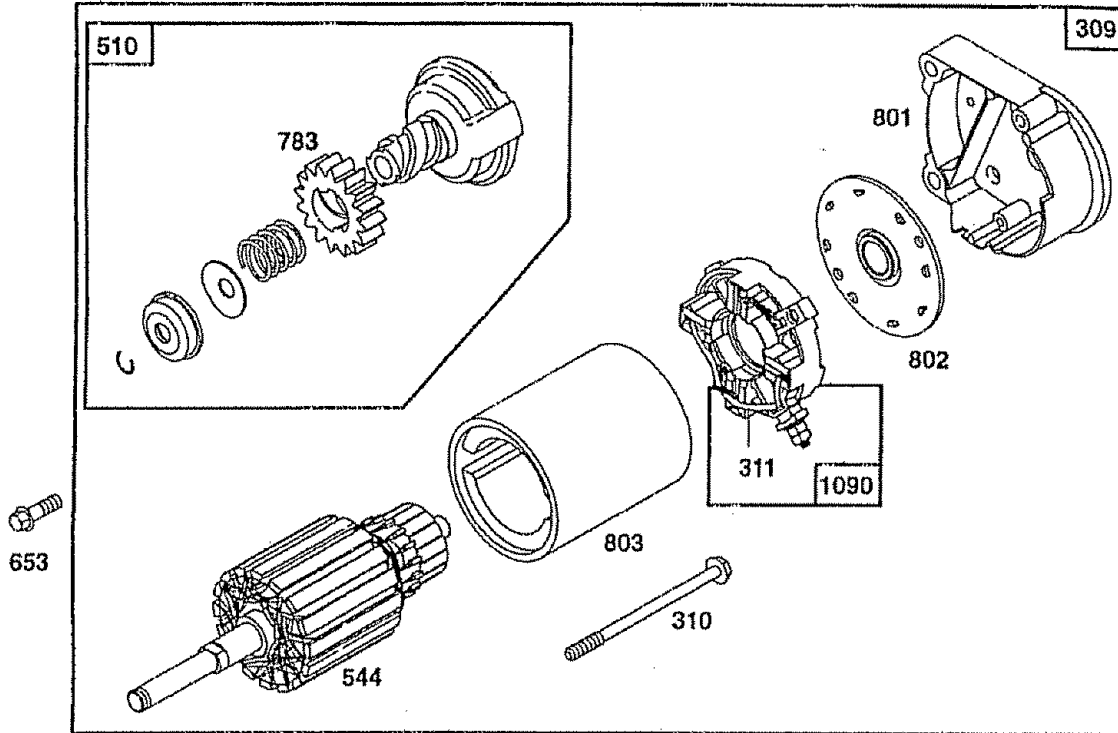

# REPAIR PARTS

TRACTOR - - MODEL NUMBER 917.258670

BRIGGS & STRATTON ENGINE - MODEL NUMBER 42E707, TYPE NUMBER 1631-01

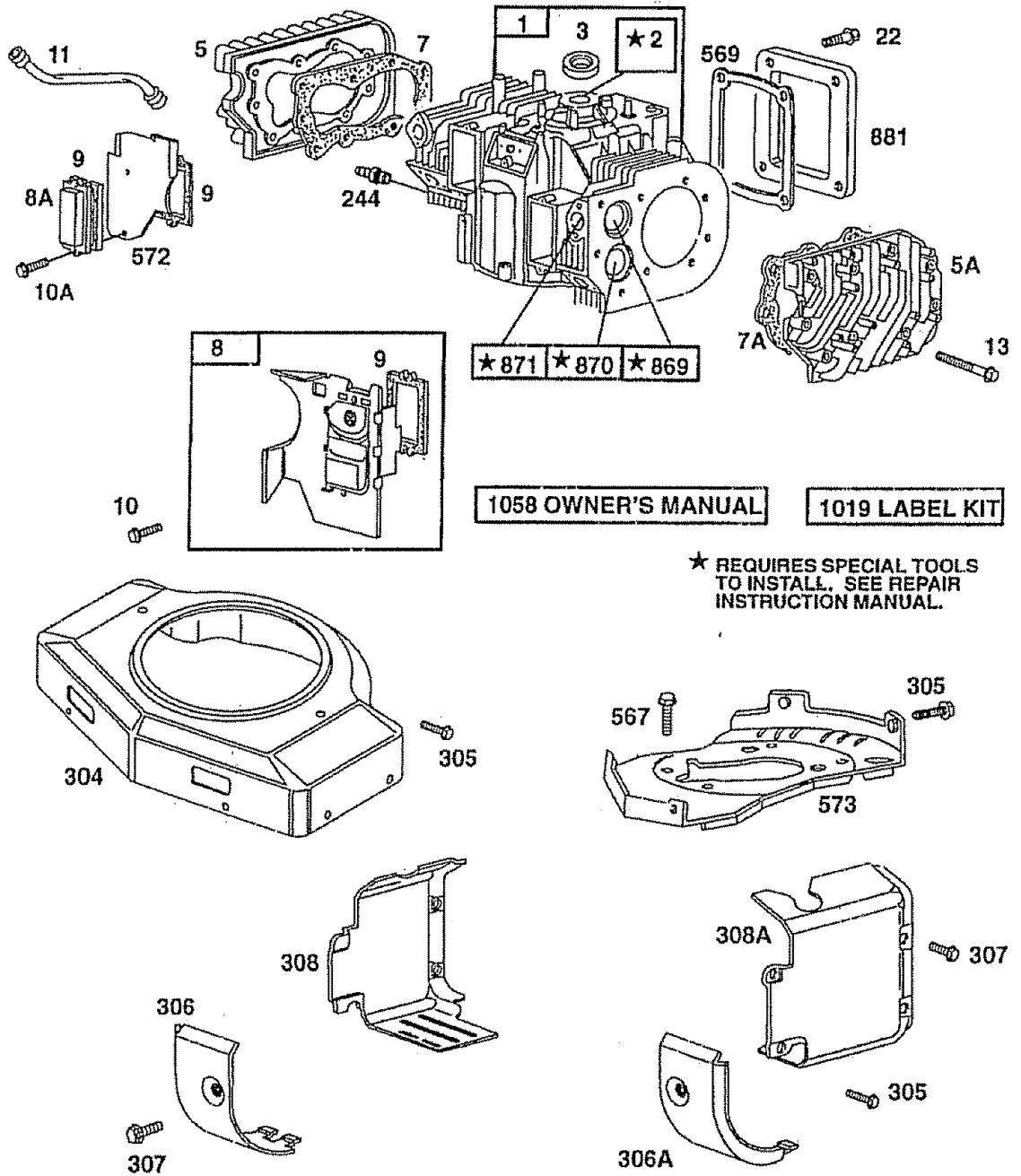

# REPAIR PARTS

TRACTOR - - MODEL NUMBER 917.258670

BRIGGS & STRATTON ENGINE - MODEL NUMBER 42E707, TYPE NUMBER 1631-01

KEY PART NO.	NO.	DESCRIPTION	KEY PART NO.	NO.	DESCRIPTION
1	497074	Cylinder Assembly	54	93208	Screw, Phillips
2	399265	Bushing	75	222511	Washer, Spring
3	391086	* Seal, Oil	78	95039	Screw, Hex
4	493304	Sump, Engine	90	495181	Carburetor
5	493457	Head, Cylinder #1	91	495035	Body Assembly, Upper
5A	493458	Head, Cylinder #2	93	231209	Bushing, Throttle Shaft
7	271867	* Gasket, Cylinder Head #1	94	491538	** Valve, Idle Adjust
7A	271868	* Gasket, Cylinder Head #2	95	93499	Screw, Sems
8	495754	Breather Assembly #1	98	221939	Valve, Throttle
8A	222892	Cover, Breather Cylinder #2 (Used Only on Key #572, Air Baffle with Holes for Mounting)	97	392672	Shaft, Throttle
			98	91920	Screw, Fillister Head
			99	26157	Spring, Throttle Adjust
9	27803	* Gasket, Breather	102	271607	** Gasket, Carburetor Body
10	94382	Screw, Sems	103	298514	Float, Carburetor
10A	94830	Screw, Sems	104	231435	** Pin, Float Hinge
11	280225	Tube, Breather	105	394683	** Valve, Needle
12	273208	* Gasket, Crankcase, .015" Thick	107	491543	Body Assembly, Lower
	271188	* Gasket, Crankcase, .005" Thick	108	223534	Valve, Choke
	271189	* Gasket, Crankcase, .009" Thick	109	392673	Shaft, Choke
13	94565	Screw, Cylinder Head	116	280474	* O-Ring
15	94239	Plug, Oil Drain	117	231338	Jet, Needle Valve, Fixed
16	394028	Crankshaft		231333	Jet, Needle Valve, Fixed, High Altitude
	94196	Timing Gear Key	119	94152	Screw, Hex Head
20	291675	* Seal, Oil	121	491539	Carburetor Kit
22	94724	Screw, Sems	127	223472	** Plug, Welch
23	491180	Flywheel	161	496599	Base, Air Cleaner
24	222698	Key, Flywheel	165	94289	Nut, Wing
25	498584	Piston Assembly, Standard Size	187	299146	Line, Fuel, 28" Long (Cut to Suit)
	498585	Piston Assembly, .010" Oversize	188	94627	Screw
	498586	Piston Assembly, .020" Oversize	201	262683	Link
	498587	Piston Assembly, .030" Oversize	202	262684	Link
26	394959	Ring Set, Standard Size	203	280997	Crank, Bell
	394960	Ring Set, .010" Oversize	205	93971	Screw, Hex Head
	394961	Ring Set, .020" Oversize	206	94298	Nut
	394962	Ring Set, .030" Oversize	207	262337	Spring, Control, Rod
27	263129	Lock, Piston Pin	209	262352	Spring, Governor
28	498319	Pin, Piston, Standard Size	209A	261563	Spring, Governor Idle
	391286	Pin, Piston, .005" Oversize	219	394348	Gear, Governor
29	394306	Rod, Connecting, Standard Size	219A	393415	Oil Slinger
	397158	Rod, Connecting, .020" Undersize	220	222773	Washer, Thrust
32	94671	Screw, Connecting Rod	222	491282	Bracket, Control
33	390420	Valve, Exhaust	224	94297	Screw, Torx®
34	261528	Valve, Intake			
35	65906	Spring, Valve, Intake			
36	26828	Spring, Valve, Exhaust			
40	221596	Retainer, Valve, Intake			
41	292260	Retainer, Valve, Exhaust			
42	494553	Keeper, Valve			
45	261368	Tappet, Valve			
46	213520	Gear, Cam			
50	213290	Manifold, Intake			
51	271412	**** Gasket, Carburetor Mounting			
51A	281411	Spacer, Carburetor			
52	270884	* Gasket, Intake Manifold Mounting			
53	93970	Screw, Hex Head, Carburetor to Manifold			

NOTE: All component dimensions given in U.S. Inches  
1 inch = 25.4 mm

# REPAIR PARTS

## TRACTOR - - MODEL NUMBER 917.258670

BRIGGS & STRATTON ENGINE - MODEL NUMBER 42E707, TYPE NUMBER 1631-01

KEY PART NO.	NO.	DESCRIPTION	KEY PART NO.	NO.	DESCRIPTION
227	491297	Lever Assembly, Governor	556	93585	Screw, Hex Head
229	62199	Washer	562	93853	Bolt, Governor Lever
230	223882	Washer, Governor Crank, Inside	567	94811	Screw, Hex Head, Back Plate to Cylinder
235	224995	Shield, Fuel Spray	569	272645	* Gasket, Base
240	394358	Filter, Fuel	572	224816	Baffle, Air, Cylinder #2
244	230318	Connector, Fuel Line	573	491304	Plate, Back
257	93897	Screw, Sems	592	92278	Nut, Hex.
258	94623	Screw, Sems	601	93053	Clamp, Hose
259	223890	Bracket, Cable	615	94296	Retainer, E-Ring
265	221535	Clamp, Casing	615A	263080	Retainer
267	94906	Screw, Sems	616	491530	Crank, Governor
284	94674	Screw, Hex Head	634	271013	** Washer, Throttle Shaft
284A	94882	Screw, Hex Head	634A	491287	* Seal, Governor Shaft
304	495469	Housing, Blower, Red	635	66538	Boot, Spark Plug
305	94786	Screw, Sems	642	225008	Cover, Air Cleaner
306	222846	Shield, Cylinder	643	496700	Plate, Air Cleaner
306A	223734	Shield, Cylinder	653	93585	Screw, Hex Head
307	94930	Screw, Self-Tapping	726	391362	Gear, Ring (includes Mounting Parts)
308	224774	Cover, Air Guide	741	262989	Gear, Timing
308A	224775	Cover, Air Guide	783	280104	Gear, Starter
309	497596	Motor, Starter	801	394860	Cap, Drive
310	94003	Bolt, Thru	802	497607	Cap, End
311	497608	Brush Set	803	497604	Housing, Starter
332	230674	Nut, Hex	819	94675	Screw, Hex Head
333	394891	Armature, Magneto	842	270920	* Seal, Cap
334	94731	Screw, Sems	847	495715	Tube Assembly, Oil
337	802592	Plug, Spark	851	493880	Terminal, Cable
356	494705	Wire, Stop	858	270989	*** Diaphragm, Carburetor
358	491856	Gasket Set	859	271025	*** Gasket, Pump
363	19203	Flywheel Puller	860	261358	*** Spring, Diaphragm
363	89838	Wrench, Spark Plug	861	393397	Repair Kit, Pump
387	280197	Body, Pump	868	497212	Seal, Valve
392	261395	*** Spring, Diaphragm	869	261463	Seat, Valve, Intake
394	270988	*** Diaphragm, Carburetor	870	213316	Seat, Valve, Exhaust
414	220680	Washer	871	261961	Bushing, Guide (Exhaust Only)
422	222875	Bracket, Oil Fill		231218	Bushing, Guide (Intake, Brass)
432	221377	*** Cap, Spring	877	393456	Wire, Alternator
434	223688	Cover, Diaphragm	881	495901	Plate, Cover
435	93829	Screw, Diaphragm Cover	955	397882	Plug and Seal, Solenoid
445	394019	Filler, Air	1005	281053	Fan, Flywheel
468	497908	Screen, Rotating	1006	224901	Retainer, Fan
474	393474	Alternator	1019	496726	Label Kit
482	93621	Screw,	1058	272112	Owner's Manual
510	497606	Drive, Starter	1090	497605	Retainer, Brush
523	494947	Cap, Oil Fill			* Included in Gasket Set (495868)
524	271157	* Seal, Fill Tube			** Included in Carburetor Kit (491539)
525	495348	Tube, Oil Fill (Includes Seals)			*** Included in Carburetor Kit (491539), and Pump Repair Kit (393397)
528	393815	Hose, Vacuum			**** Included in Gasket Set (495868), and Carburetor Kit (491539)
534	94823	Screw, Air Cleaner			
535	272490	Filter, Air			
537	271411	**** Gasket, Air Cleaner			
544	497603	Armature, Starter			
552	262332	Lower Bushing, Governor			
552A	262331	Upper Bushing, Governor			

NOTE: All component dimensions given in U.S. Inches  
1 inch = 25.4 mm

---

## SERVICE NOTES

---

---

## SERVICE NOTES

---

---

## SERVICE NOTES

---

# SUGGESTED GUIDE FOR SIGHTING SLOPES FOR SAFE OPERATION

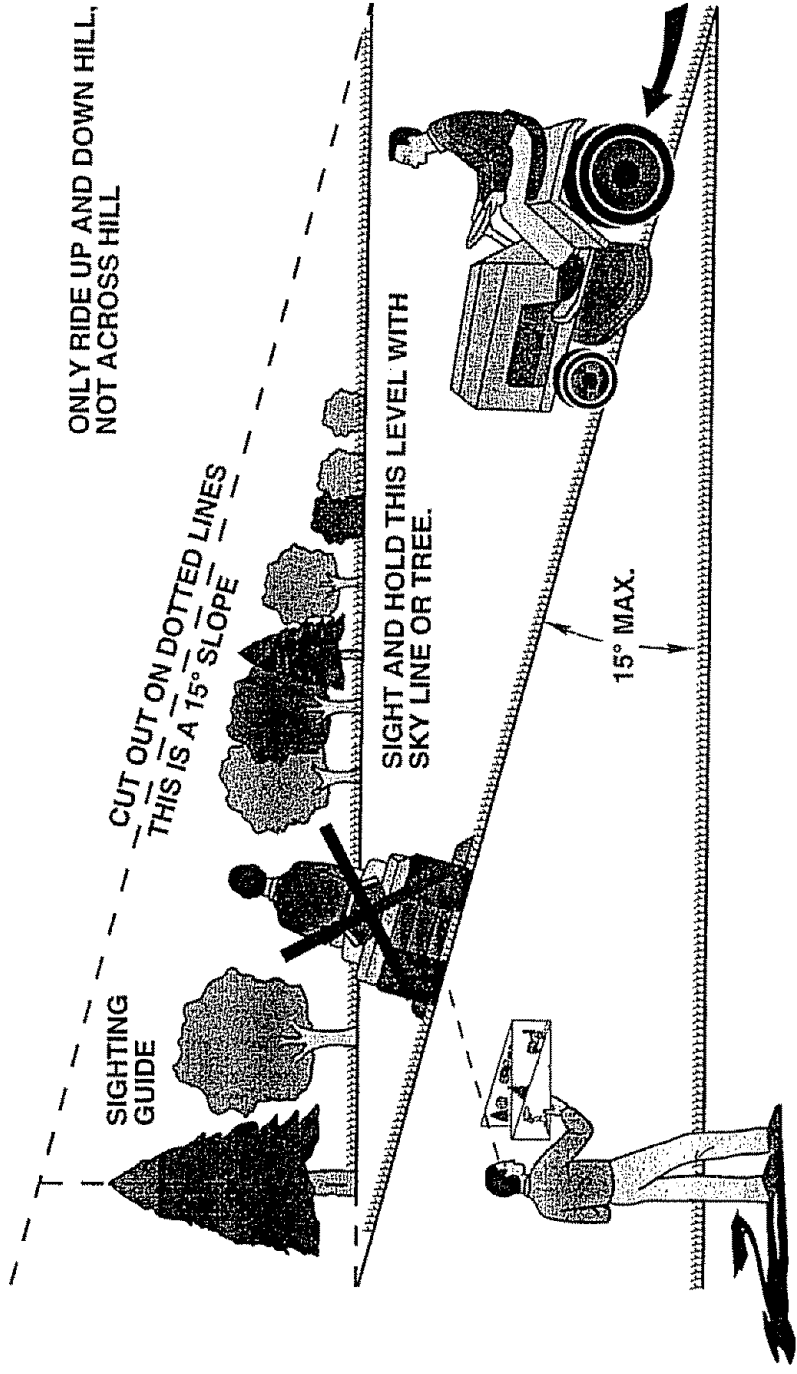

 Operate your Tractor up and down the face of slopes (not greater than 15°), never across the face. Make turns gradually to prevent tipping or loss of control. Exercise extreme caution when changing direction on slopes.

**SEARS**

**OWNER'S  
MANUAL**

**MODEL NO.  
917.258670**

**IF YOU NEED  
REPAIR SERVICE  
OR PARTS:**

FOR REPAIR SERVICE, CALL  
THIS TOLL FREE NUMBER:

**1-800-4-REPAIR**  
(1-800-473-7247)

FOR REPLACEMENT PARTS  
INFORMATION AND  
ORDERING, CALL THIS  
TOLL FREE NUMBER:

**1-800-FON-PART**  
(1-800-366-7278)

FOR CONSUMER ASSISTANCE  
HOT LINE, CALL THIS  
TOLL FREE NUMBER:

**1-800-659-5917**

**CRAFTSMAN®**

**19.5 HP  
ELECTRIC START  
46" MOWER  
AUTOMATIC (HYDROSTATIC)  
LAWN TRACTOR**

Each tractor has its own model number. Each engine has its own model number.

The model number for your tractor will be found on the model plate located under the seat.

The model number for your engine will be found on the blower housing of the engine.

All parts listed herein may be ordered from any Sears, Roebuck and Co. Service Center/Department and most Retail Stores.

**WHEN ORDERING REPAIR PARTS, ALWAYS GIVE THE  
FOLLOWING INFORMATION:**

- PRODUCT - TRACTOR
- MODEL NUMBER - 917.258670
- ENGINE MODEL NO. - 42E707-1631-01
- PART NUMBER
- PART DESCRIPTION

Your Sears merchandise has added value when you consider Sears has service units nationwide staffed with Sears trained technicians... professional technicians specifically trained to insure that we meet our pledge to you, we service what we sell.