

# INSTALLATION INSTRUCTIONS

## 30" (76 CM) FREESTANDING ELECTRIC RANGES

### Table of Contents

<b>RANGE SAFETY</b> .....	1
<b>INSTALLATION REQUIREMENTS</b> .....	2
Tools and Parts .....	2
Location Requirements.....	2
Electrical Requirements .....	3
<b>INSTALLATION INSTRUCTIONS</b> .....	4
Unpack Range .....	4
Install Anti-Tip Bracket.....	5
Electrical Connection .....	6
Verify Anti-Tip Bracket Location.....	9
Level Range.....	9
Complete Installation .....	10
Moving the Range.....	10
<b>ANTI-TIP BRACKET TEMPLATE</b> .....	11

## RANGE SAFETY

### Your safety and the safety of others are very important.

We have provided many important safety messages in this manual and on your appliance. Always read and obey all safety messages.



This is the safety alert symbol.

This symbol alerts you to potential hazards that can kill or hurt you and others.

All safety messages will follow the safety alert symbol and either the word "DANGER" or "WARNING."

These words mean:

**⚠ DANGER**

You can be killed or seriously injured if you don't immediately follow instructions.

**⚠ WARNING**

You can be killed or seriously injured if you don't follow instructions.

All safety messages will tell you what the potential hazard is, tell you how to reduce the chance of injury, and tell you what can happen if the instructions are not followed.



### ⚠ WARNING

#### Tip Over Hazard

A child or adult can tip the range and be killed.

Connect anti-tip bracket to rear range foot.

Reconnect the anti-tip bracket, if the range is moved.

Failure to follow these instructions can result in death or serious burns to children and adults.

### IMPORTANT:

Save for local electrical inspector's use.

# INSTALLATION REQUIREMENTS

## Tools and Parts

Gather the required tools and parts before starting installation. Read and follow the instructions provided with any tools listed here.

### Tools needed

- Tape measure
- Flat-blade screwdriver
- Level
- Hammer
- Hand or electric drill
- Wrench or pliers
- Marker or pencil
- Masking tape
- $\frac{3}{8}$ " drive ratchet
- $\frac{1}{4}$ " nut driver
- $\frac{3}{8}$ " and  $\frac{5}{16}$ " nut driver
- $\frac{1}{8}$ " (3.2 mm) drill bit (for wood floors)
- $\frac{3}{16}$ " (4.8 mm) carbide-tipped masonry drill bit (for concrete/ceramic floors)

### Parts supplied

Check that all parts are included.

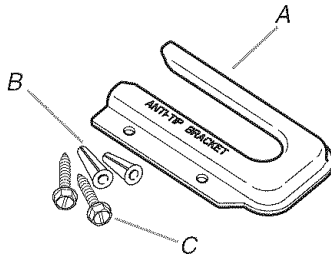

A. Anti-tip bracket  
B. Plastic anchors (2)  
C. #10 x 1 1/2" screws (2)

- Anti-tip brackets must be securely mounted to subfloor. Thickness of flooring may require longer screws to anchor bracket to subfloor. Longer screws are available from your local hardware store.

### Parts needed

If using a power supply cord kit:

- A UL listed power supply cord kit marked for use with ranges. The cord should be rated at 250 volts minimum, 40 amps or 50 amps that is marked for use with nominal 1 3/8" (3.5 cm) diameter connection opening and must end in ring terminals or open-end spade terminals with upturned ends.
- A UL listed strain relief.

Check local codes. Check existing electrical supply. See "Electrical Requirements" section.

All electrical connections should be made by a licensed, qualified electrical installer.

## Location Requirements

**IMPORTANT:** Observe all governing codes and ordinances.

- It is the installer's responsibility to comply with installation clearances specified on the model/serial rating plate. The model/serial rating plate is located on the left side frame behind the storage drawer panel.
- The range should be located for convenient use in the kitchen.
- To eliminate the risk of burns or fire by reaching over heated surface units, cabinet storage space located above the surface units should be avoided. If cabinet storage is to be provided, the risk can be reduced by installing a range hood that projects horizontally a minimum of 5" (12.7 cm) beyond the bottom of the cabinets.
- Cabinet opening dimensions that are shown must be used. Given dimensions are minimum clearances.
- The floor anti-tip bracket must be installed. To install the anti-tip bracket shipped with the range, see "Install Anti-Tip Bracket" section.
- Grounded electrical supply is required. See "Electrical Requirements" section.

**IMPORTANT:** To avoid damage to your cabinets, check with your builder or cabinet supplier to make sure that the materials used will not discolor, delaminate or sustain other damage. This oven has been designed in accordance with the requirements of UL and CSA International and complies with the maximum allowable wood cabinet temperatures of 194° (90°C).

### Mobile Home - Additional Installation Requirements

The installation of this range must conform to the Manufactured Home Construction and Safety Standard, Title 24 CFR, Part 3280 (formerly the Federal Standard for Mobile Home Construction and Safety, Title 24, HUD Part 280). When such standard is not applicable, use the Standard for Manufactured Home Installations, ANSI A225.1/NFPA 501A or local codes.

#### Mobile home installations require:

- When this range is installed in a mobile home, it must be secured to the floor during transit. Any method of securing the range is adequate as long as it conforms to the standards listed above.
- Four-wire power supply cord or cable must be used in a mobile home installation. The appliance wiring will need to be revised. See "Electrical Connection" section.

## Product Dimensions

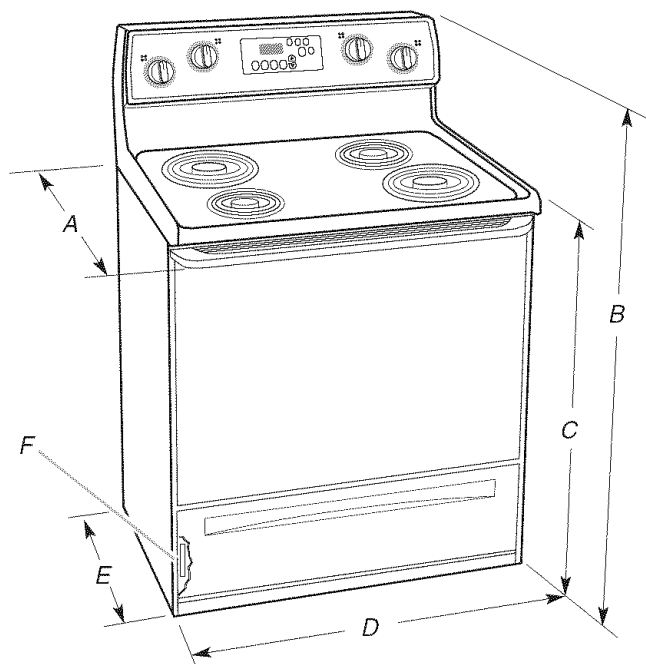

- A. 27<sup>1</sup>/<sub>8</sub>" (68.9 cm) depth with handle  
28<sup>1</sup>/<sub>8</sub>" (71.6 cm) depth with handle (KitchenAid models only)
- B. 46<sup>7</sup>/<sub>8</sub>" (119.1 cm) overall height  
46" (116.8 cm) overall height (KitchenAid models only)
- C. 36" (91.4 cm) cooktop height
- D. 29<sup>7</sup>/<sub>8</sub>" (75.9 cm) width
- E. 24<sup>1</sup>/<sub>16</sub>" (63.0 cm) depth
- F. Model/serial rating plate (located on the left side frame behind storage drawer panel)

## Cabinet Dimensions

Cabinet opening dimensions shown are for 25" (64.0 cm) countertop depth, 24" (61.0 cm) base cabinet depth and 36" (91.4 cm) countertop height.

If installing a range hood or microwave hood combination above the range, follow the range hood or microwave hood combination installation instructions for dimensional clearances above the cooktop surface.

A freestanding range may be installed next to combustible walls with zero clearance.

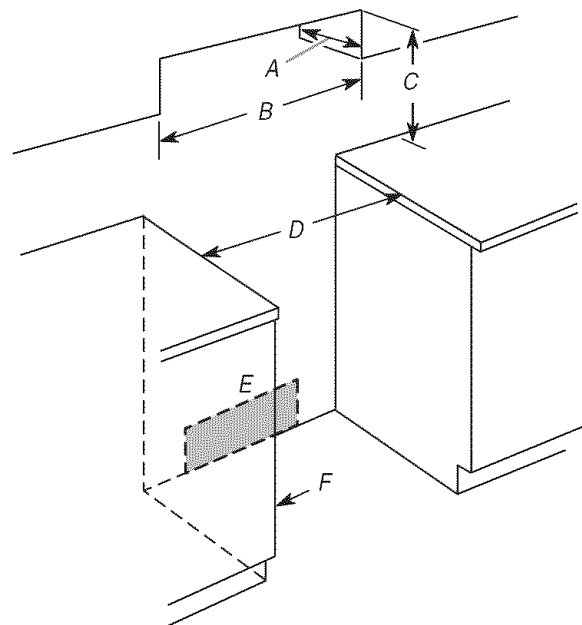

- A. 13" (33.0 cm) max. upper cabinet depth
- B. 30" (76.2 cm) min. opening width
- C. For minimum clearance to top of cooktop, see NOTE\*.
- D. 30" (76.2 cm) min. opening width
- E. Outlet - 8" (20.3 cm) to 22" (55.9 cm) from either cabinet, 5<sup>1</sup>/<sub>2</sub>" (14.0 cm) max. from floor
- F. <sup>7</sup>/<sub>8</sub>" (2.2 cm) min. required between cutout and cabinet door or hinge.

**\*NOTE:** 24" (61.0 cm) minimum when bottom of wood or metal cabinet is protected by not less than <sup>1</sup>/<sub>4</sub>" (0.64 cm) flame retardant millboard covered with not less than No. 28 MSG sheet steel, 0.015" (0.4 mm) stainless steel, 0.024" (0.6 mm) aluminum or 0.020" (0.5 mm) copper.

30" (76.2 cm) minimum clearance between the top of the cooking platform and the bottom of an unprotected wood or metal cabinet.

## Electrical Requirements

If codes permit and a separate ground wire is used, it is recommended that a qualified electrical installer determine that the ground path and wire gauge are in accordance with local codes.

If codes permit and a separate ground wire is used, it is recommended that a qualified electrician determine that the ground path is adequate.

Do not use an extension cord.

Be sure that the electrical connection and wire size are adequate and in conformance with the National Electrical Code, ANSI/NFPA 70-latest edition and all local codes and ordinances.

A copy of the above code standards can be obtained from:  
National Fire Protection Association  
One Batterymarch Park  
Quincy, MA 02269.

**WARNING:** Improper connection of the equipment-grounding conductor can result in a risk of electric shock. Check with a qualified electrician or service technician if you are in doubt as to whether the appliance is properly grounded. Do not modify the power supply cord plug. If it will not fit the outlet, have a proper outlet installed by a qualified electrician.

## Electrical Connection

To properly install your range, you must determine the type of electrical connection you will be using and follow the instructions provided for it here.

- Range must be connected to the proper electrical voltage and frequency as specified on the model/serial number rating plate. The model/serial number rating plate is located on the oven frame behind the storage drawer panel. Refer to the figures in the "Product Dimensions" section of the "Location Requirements" section.
- This range is manufactured with the neutral terminal connected to the cabinet. Use a 3-wire, UL listed, 40- or 50-amp power supply cord (pigtail) (see Range Rating chart below). If local codes do not permit ground through the neutral, use a 4-wire power supply cord rated at 250 volts, 40 or 50 amps and investigated for use with ranges.

Range Rating*		Specified Rating of Power Supply Cord Kit and Circuit Protection
120/240 Volts	120/208 Volts	Amps
8.8 - 16.5 KW	7.8 - 12.5 KW	40 or 50**
16.6 - 22.5 KW	12.6 - 18.5 KW	50

\*The NEC calculated load is less than the total connected load listed on the model/serial rating plate.

\*\*If connecting to a 50-amp circuit, use a 50-amp rated cord with kit. For 50-amp rated cord kits, use kits that specify use with a nominal 1 $\frac{3}{8}$ " (34.9 mm) diameter connection opening.

- A time-delay fuse or circuit breaker is recommended.
- The range can be connected directly to the fused disconnect (or circuit breaker box) through flexible or nonmetallic sheathed, copper or aluminum cable. See "Electrical Connection."
- Allow 2 to 3 ft (61.0 cm to 91.4 cm) of slack in the line so that the range can be moved if servicing is ever necessary.
- A UL listed conduit connector must be provided at each end of the power supply cable (at the range and at the junction box).
- Wire sizes and connections must conform with the rating of the range.
- The wiring diagram is located on the back of the range or inside the storage drawer in a clear plastic bag.

## If connecting to a 4-wire system:

This range is manufactured with the ground connected to the cabinet. The ground must be revised so the green ground wire of the 4-wire power supply cord is connected to the cabinet. See "Electrical Connection."

Grounding through the neutral conductor is prohibited for new branch-circuit installations (1996 NEC); mobile homes; and recreational vehicles, or an area where local codes prohibit grounding through the neutral conductor.

When a 4-wire receptacle of NEMA Type 14-50R is used, a matching UL listed, 4-wire, 250-volt, 40- or 50-amp, range power supply cord (pigtail) must be used. This cord contains 4 copper conductors with ring terminals or open-end spade terminals with upturned ends, terminating in a NEMA Type 14-50R plug on the supply end.

The fourth (grounding) conductor must be identified by a green or green/yellow cover and the neutral conductor by a white cover. Cord should be Type SRD or SRDT with a UL listed strain relief and be at least 4 ft (1.22 m) long.

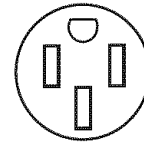

4-wire receptacle (14-50R)

The minimum conductor sized for the copper 4-wire power cord are:

- 40-amp circuit
- 2 No.-8 conductors
- 1 No.-10 white neutral
- 1 No.-8 green grounding

## If connecting to a 3-wire system:

Local codes may permit the use of a UL listed, 3-wire, 250-volt, 40- or 50-amp range power supply cord (pigtail). This cord contains 3 copper conductors with ring terminals or open-end spade terminals with upturned ends, terminating in a NEMA Type 10-50P plug on the supply end. Connectors on the appliance end must be provided at the point the power supply cord enters the appliance. This uses a 3-wire receptacle of NEMA Type 10-50R.

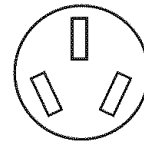

3-wire receptacle (10-50R)

# INSTALLATION INSTRUCTIONS

## Unpack Range

### **WARNING**

#### Excessive Weight Hazard

Use two or more people to move and install range.  
Failure to do so can result in back or other injury.

1. Remove shipping materials, tape and protective film from range. Remove oven racks and parts package from inside oven.

2. Do not remove the shipping base at this time.

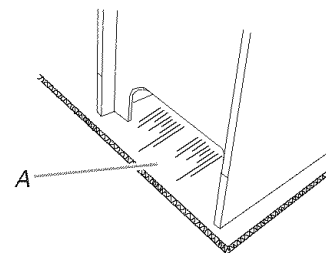

A. Shipping base

### 3. On Ranges Equipped with Storage Drawers:

Remove the storage drawer. Use a  $\frac{3}{8}$ " drive ratchet to lower the rear leveling legs one-half turn. Use a wrench or pliers to lower front leveling legs one-half turn.

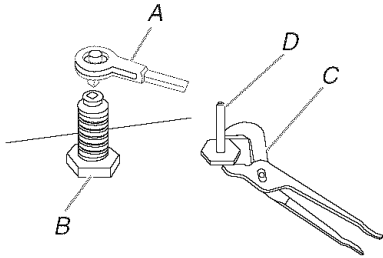

A.  $\frac{3}{8}$ " drive ratchet  
B. Rear leveling leg  
C. Wrench or pliers  
D. Front leveling leg

### On Ranges Equipped with Warming Drawers:

Use a wrench or pliers to lower the front and rear leveling legs one-half turn.

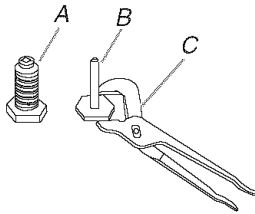

A. Rear leveling leg  
B. Front leveling leg  
C. Wrench or pliers

2. Place template on the floor in cabinet opening so that the left edge is against cabinet and top edge is against rear wall, molding or cabinet.
3. Tape template into place.
4. If countertop is not flush with cabinet opening edge, align template with overhang.

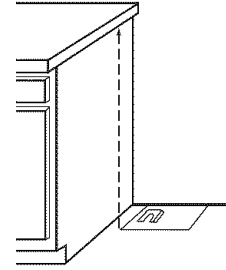

If cabinet opening is wider than that specified in the "Location Requirements" section, adjust template so range will be centered in cabinet opening.

5. To mount anti-tip bracket to wood floor, drill two  $\frac{1}{8}$ " (3.2 mm) holes at the positions marked on the bracket template. Remove template from floor.

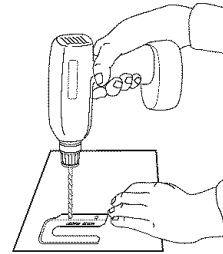

To mount anti-tip bracket to concrete or ceramic floor, use a  $\frac{3}{16}$ " (4.8 mm) masonry drill bit to drill 2 holes at the positions marked on the bracket template. Remove template from floor.

6. Tap plastic anchors into holes with a hammer.
7. Align anti-tip bracket holes with holes in floor. Fasten anti-tip bracket with screws provided.

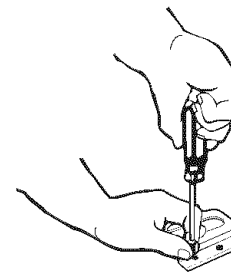

Depending on the thickness of your flooring, longer screws may be necessary to anchor the bracket to the subfloor. Longer screws are available from your local hardware store.

8. Move range close enough to opening to allow for electrical connections to be made. Remove shipping base, cardboard or hardboard from under range.
9. Make electrical connections as described in the "Electrical Connection" section.

## Install Anti-Tip Bracket

### ⚠ WARNING



#### Tip Over Hazard

**A child or adult can tip the range and be killed.**

**Connect anti-tip bracket to rear range foot.**

**Reconnect the anti-tip bracket, if the range is moved.**

**Failure to follow these instructions can result in death or serious burns to children and adults.**

Contact a qualified floor covering installer for the best procedure for drilling mounting holes through your type of floor covering.

Before moving range, slide range onto shipping base, cardboard or hardboard.

1. Remove template from the anti-tip bracket kit (found inside the oven cavity) or from the back of this manual.

10. Move range into its final location making sure rear leveling leg slides into anti-tip bracket.

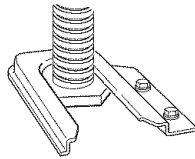

11. If installing the range in a mobile home, you must secure the range to the floor. Any method of securing the range is adequate as long as it conforms to the standards in the "Location Requirements" section.
12. Continue installing your range using the following installation instructions.

## Electrical Connection

### Power Supply Cord

#### ⚠ WARNING



#### Electrical Shock Hazard

Disconnect power before servicing.

Use a new 40 amp power supply cord.

Plug into a grounded outlet.

Failure to follow these instructions can result in death, fire, or electrical shock.

### Direct Wire

#### ⚠ WARNING



#### Electrical Shock Hazard

Disconnect power before servicing.

Use 8 gauge copper or 6 gauge aluminum wire.

Electrically ground range.

Failure to follow these instructions can result in death, fire, or electrical shock.

1. Disconnect power.
2. Remove the terminal block cover screws located on the back of the range. Pull cover down and toward you to remove cover from range.

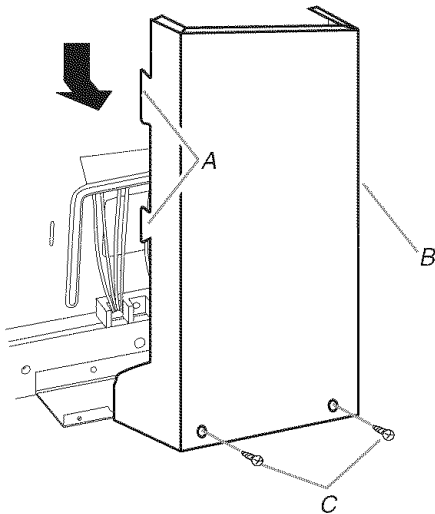

A. Two mounting tabs each side  
B. Terminal block cover  
C. Hex-head screws

3. Add strain relief.

#### Style 1: Power supply cord strain relief

- Remove the knockout for the power supply cord.
- Assemble a UL listed strain relief in the opening.

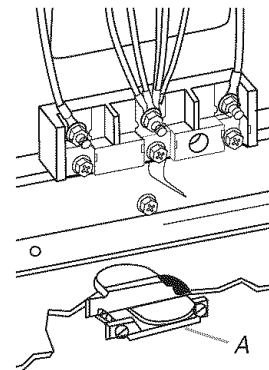

A. UL listed strain relief

- Tighten strain relief screw against the power supply cord.

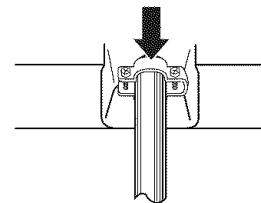

## Style 2: Direct wire strain relief

- Remove the knockout as needed for the flexible conduit connection.
- Assemble a UL listed conduit connector in the opening.

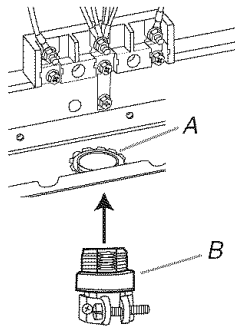

A. Removable retaining nut  
B. Strain relief

- Tighten strain relief screw against the flexible conduit.

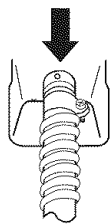

- Complete installation following instructions for your type of electrical connection:

**4-wire** (recommended)

**3-wire** (if 4-wire is not available)

### Electrical Connection Options

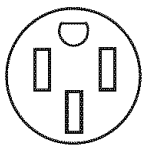
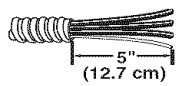
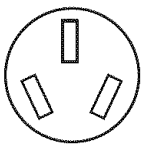
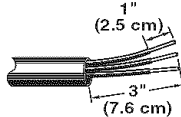
If your home has:	And you will be connecting to:	Go to Section:
4-wire receptacle (NEMA type 14-50R) 	A UL listed, 250-volt minimum, 40-amp, range power supply cord	4-wire connection: Power supply cord
4-wire direct 	A fused disconnect or circuit breaker box	4-wire connection: Direct wire
3-wire receptacle (NEMA type 10-50R) 	A UL listed, 250-volt minimum, 40-amp, range power supply cord	3-wire connection: Power supply cord
3-wire direct 	A fused disconnect or circuit breaker box	3-wire connection: Direct wire

## 4-wire connection: Power supply cord

Use this method for:

- New branch-circuit installations (1996 NEC)
  - Mobile homes
  - Recreational vehicles
  - In an area where local codes prohibit grounding through the neutral
- Remove the ground-link screw from the range frame. Save the ground link screw and cup washer. Bend the ground-link away from the range so that it does not contact the range.

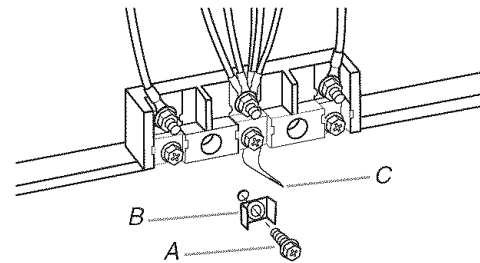

A. Ground-link screw  
B. Cup washer  
C. Ground-link bent away from range

- Connect the green ground wire from the power supply cord to the range using the ground-link screw and cup washer. The ground wire must be attached first and must not contact any other terminal.
- Use a 1/4" nut driver to remove the hex washer head screws from the terminal blocks.
- Connect the neutral (center) wire to the center terminal connector using one of the hex washer head screws. Securely tighten screw for proper electrical connection.

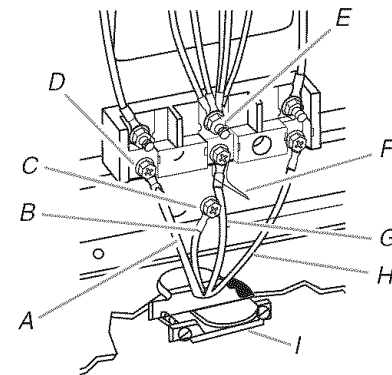

A. Line 1  
B. Green ground wire  
C. Ground-link screw  
D. Hex washer head screw  
E. Silver-colored terminal block screw  
F. Ground-link  
G. Neutral (center) wire  
H. Line 2  
I. UL listed strain relief and 40- or 50-amp range power supply cord

- Connect the other 2 wires (lines 1 and 2) to the outer aluminum terminal blocks.
- Securely tighten screws for proper electrical connection.
- Tighten strain relief screws.
- Replace terminal block cover.

### 3-wire connection: Power supply cord

Use this method only if local codes permit connecting cabinet-ground conductor to neutral wire of power supply cord.

1. Use a ¼" nut driver and remove the hex washer head screws from the aluminum terminal blocks.
2. Connect the neutral (center) wire to the center terminal connector using one of the hex washer head screws. Securely tighten screw for proper electrical connection.

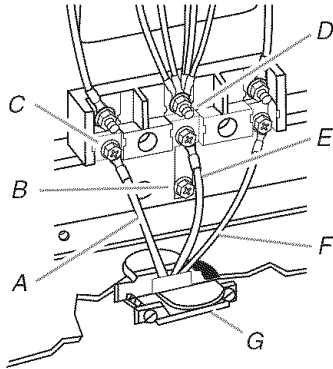

A. Line 1  
B. Ground-link  
C. Hex washer head screw  
D. Silver-colored terminal block screw  
E. Neutral (center) wire  
F. Line 2  
G. UL listed strain relief and 40- or 50-amp range power supply cord

3. Connect the other 2 wires (lines 1 and 2) to the outer terminal screws on the terminal block.
4. Tighten strain relief screws.
5. Replace terminal block cover.

### Direct Wire Installation: Copper or Aluminum Wire

This range may be connected directly to the fuse disconnect or circuit breaker box. Depending on your electrical supply, make the required 3-wire or 4-wire connection.

1. Strip outer covering back 3" (7.6 cm) to expose wires. Strip the insulation back 1" (2.5 cm) from the end of each wire.

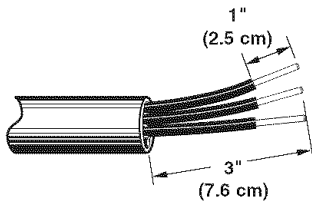

2. Allow enough slack in the wire to easily attach the wiring terminal block.
3. Complete electrical connection according to your type electrical supply (4-wire or 3-wire electrical connection).

### 4-wire connection: Direct wire

Use this method for:

- New branch-circuit installations (1996 NEC)
- Mobile homes
- Recreational vehicles

- In an area where local codes prohibit grounding through the neutral
1. Remove the ground-link screw from the range frame. Save the ground-link screw and cup washer. Bend the ground-link away from the range so that it does not contact the range.

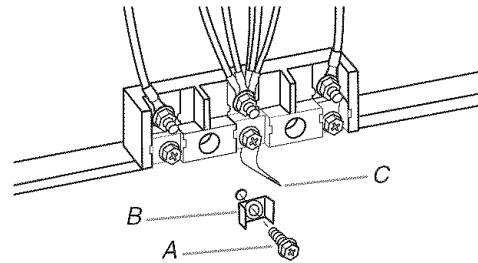

A. Ground-link screw  
B. Cup washer  
C. Ground-link bent away from range

2. Connect the bare ground wire to the range using the ground-link screw and cup washer. The ground wire must be attached first and must not contact any other terminal.

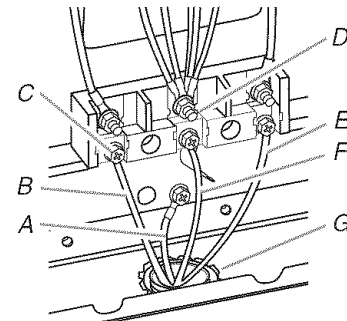

A. Bare wire from power supply cable  
B. Line 1  
C. Hex washer head screw  
D. Silver-colored terminal block screw  
E. Line 2  
F. Neutral (white) wire  
G. UL listed strain relief and power supply cable

3. Loosen (do not remove) the hex washer head screw and insert the neutral (white) wire under the screw clamp at the bottom of the center position terminal connector.
4. Insert the other 2 wires (lines 1 and 2) under the other 2 screw clamps.

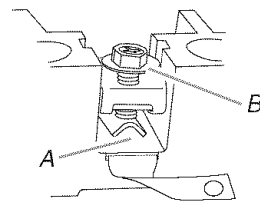

A. Insert wire under screw clamp.  
B. Hex washer head screw

5. Securely tighten the hex washer head screws to 35 lbs-in. (4.0 N-m) minimum torque to make proper electrical connection.
6. Tighten the locking ring of the conduit connector.
7. Replace the terminal block cover.



### 3-wire connection: Direct wire

Use this method only if local codes permit connecting ground conductor to neutral supply wire.

- Loosen (do not remove) the hex washer head screws and insert the neutral (white) wire under the screw clamp at the bottom of the center position terminal connector.

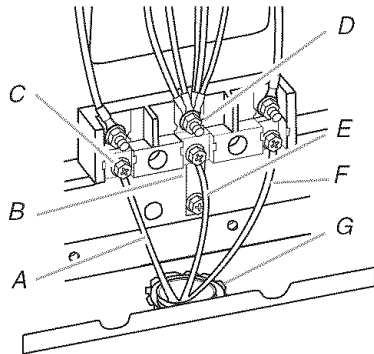

- |  |   |
|--|---|
| A. Line 1                              | E. Neutral (white) wire                           |
| B. Ground-link                         | F. Line 2   |
| C. Hex washer head screw               | G. UL listed strain relief and power supply cable |
| D. Silver-colored terminal block screw |   |

- Insert the other 2 wires (lines 1 and 2) under the other 2 screw clamps.

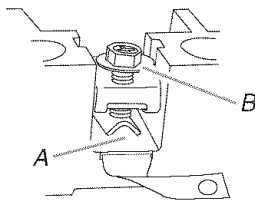

- A. Insert wire under screw clamp.  
B. Hex washer head screw

- Securely tighten the hex washer head screws to 35 lbs-in. (4.0 N-m) minimum torque to make a proper electrical connection.
- Tighten the locking ring of the conduit connector.
- Replace the terminal block cover.

### Verify Anti-Tip Bracket Location

- Pull drawer open to first stop position. Lift front of drawer to clear white wheels in drawer guides. Remove drawer and set it aside on a protected surface.

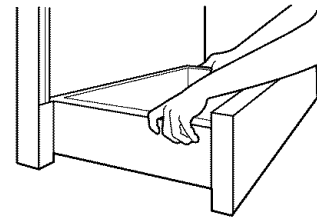

- Making sure the anti-tip bracket is installed:
  - Look for the anti-tip bracket securely attached to floor.
  - Slide range back so rear range foot is under anti-tip bracket.

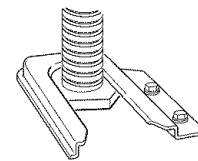

- If installing the range in a mobile home, you must secure the range to the floor. Any method of securing the range is adequate as long as it conforms to the standards in the "Location Requirements" section.

### Level Range

- Place rack in oven. Place level on rack and check levelness of range, first side to side; then front to back.

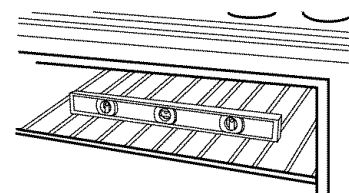

If range is not level, pull range forward until rear leveling leg is removed from the anti-tip bracket.

#### On Ranges Equipped with Storage Drawers:

Use  $\frac{3}{8}$ " drive ratchet and channel lock pliers to adjust leveling legs up or down until range is level. Push range back into position. Check that rear leveling leg is engaged in anti-tip bracket.

#### On Ranges Equipped with Warming Drawers:

Use channel lock pliers to adjust leveling legs up or down until range is level. Push range back into position. Check that rear leveling leg is engaged in anti-tip bracket.

**NOTE:** Range must be level for satisfactory baking conditions.

- Replace the storage drawer (and warming drawer on some models).

## Complete Installation

1. Check that all parts are now installed. If there is an extra part, go back through the steps to see which step was skipped.
2. Check that you have all of your tools.
3. Dispose of/recycle all packaging materials.
4. Check that the range is level. See “Level Range.”
5. Use a mild solution of liquid household cleaner and warm water to remove waxy residue caused by protective shipping material. Dry thoroughly with a soft cloth. For more information, read the “Range Care” section of the Use and Care Guide.
6. Read “Range Use” in the range Use and Care Guide.
7. Plug power cord into appropriate outlet. Turn power on.
8. Turn on surface burners and oven. See the Use and Care Guide for specific instruction on range operation.

### If range does not operate, check the following:

- Household fuse is intact and tight; or circuit breaker has not tripped.
- Range is plugged into an outlet.
- Electrical supply is connected.
- See “Troubleshooting” in the Use and Care Guide.

When the range has been on for 5 minutes, check for heat. If range is cold, turn off the range and contact a qualified technician.

## Moving the Range

### **⚠ WARNING**



#### Tip Over Hazard

**A child or adult can tip the range and be killed.**

**Connect anti-tip bracket to rear range foot.**

**Reconnect the anti-tip bracket, if the range is moved.**

**Failure to follow these instructions can result in death or serious burns to children and adults.**

When moving range, slide range onto cardboard or hardboard to avoid damaging the floor covering.

If removing the range is necessary for cleaning or maintenance:

### For power supply cord-connected ranges:

1. Unplug the power supply cord.
2. Slide range forward to complete cleaning or maintenance.
3. Check that anti-tip bracket is installed:
  - Look for the anti-tip bracket securely attached to floor.
  - Slide range back so rear range foot is under anti-tip bracket.

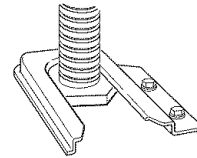

4. Check that range is level.

### For direct-wired ranges:

### **⚠ WARNING**



#### Electrical Shock Hazard

**Disconnect power before servicing.**

**Replace all parts and panels before operating.**

**Failure to do so can result in death or electrical shock.**

1. Disconnect power.
2. Disconnect wiring.
3. Slide range forward to complete cleaning or maintenance.
4. Check that anti-tip bracket is installed:
  - Look for the anti-tip bracket securely attached to floor.
  - Slide range back so rear range foot is under anti-tip bracket.

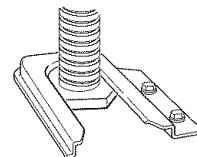

5. Check that range is level.

# ANTI-TIP BRACKET TEMPLATE

Cut on dotted lines and place the left edge against the left side cabinet and the top edge against the rear wall.

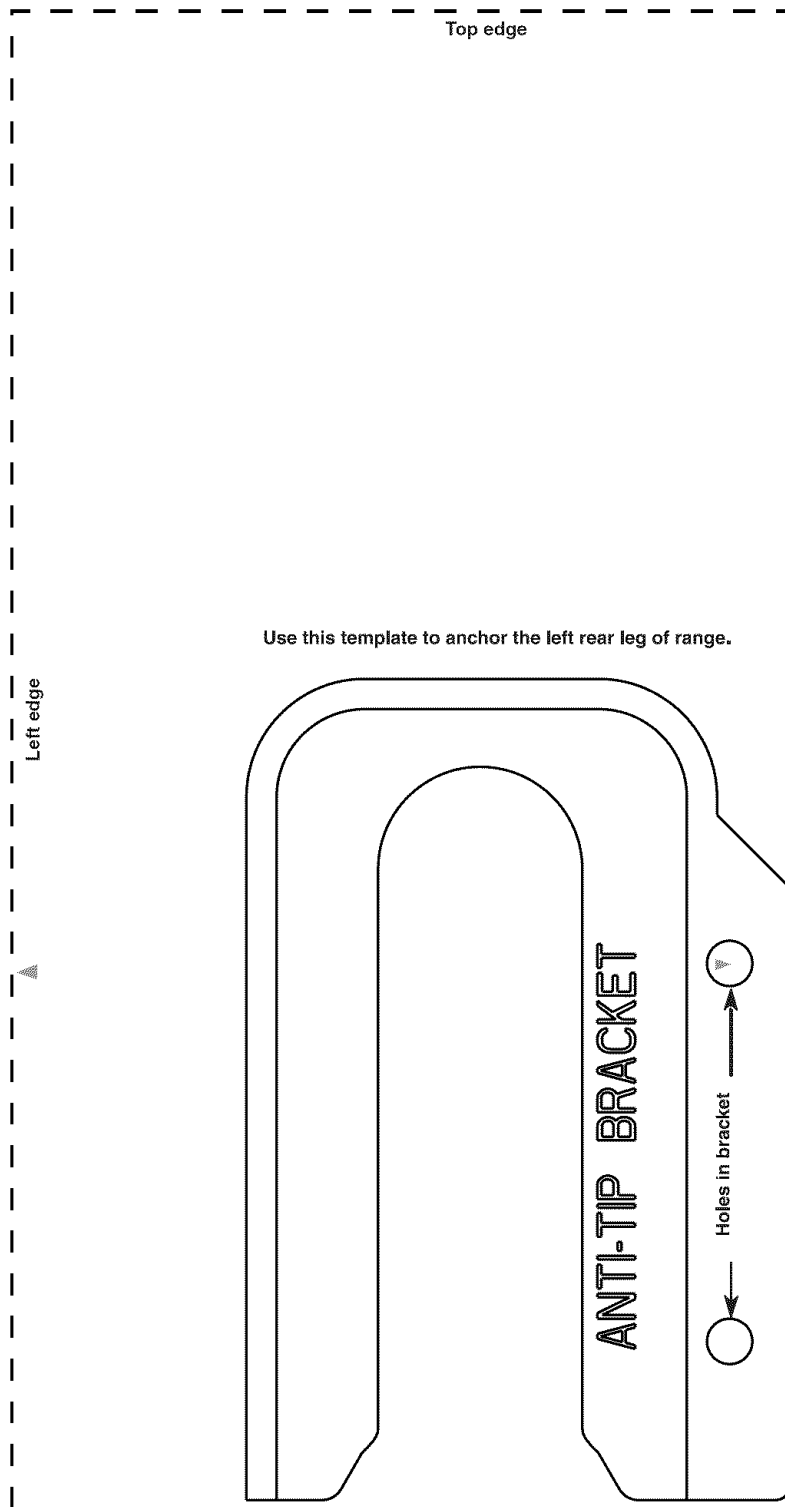

Use this template to anchor the left rear leg of range.

