

Video Projector

Operating Instructions

BRAVIA
HDMI[™]
HIGH-DEFINITION MULTIMEDIA INTERFACE

VPL-AW15
VPL-AW10

WARNING

To reduce the risk of fire or electric shock, do not expose this apparatus to rain or moisture.

To avoid electrical shock, do not open the cabinet. Refer servicing to qualified personnel only.

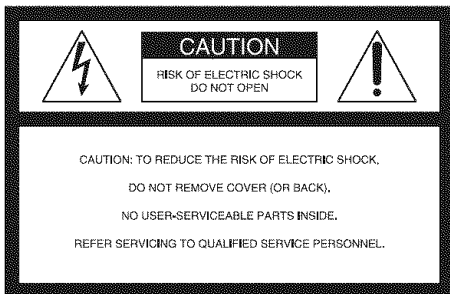

This symbol is intended to alert the user to the presence of uninsulated “dangerous voltage” within the product’s enclosure that may be of sufficient magnitude to constitute a risk of electric shock to persons.



This symbol is intended to alert the user to the presence of important operating and maintenance (servicing) instructions in the literature accompanying the appliance.

For customers in the USA

If you have any questions about this product, you may call:

Sony Customer Information Service Center
1-800-222-7669 or <http://www.sony.com/>
The number below is for FCC related matters only.

Declaration of Conformity

Trade Name: SONY

Model No.: VPL-AW15, VPL-AW10

Responsible Party: Sony Electronics Inc.

Address: 16530 Via Esprillo, San Diego, CA
92127 U.S.A.

Telephone Number: 858-942-2230

This device complies with Part 15 of the FCC Rules. Operation is subject to the following two conditions: (1) This device may not cause harmful interference, and (2) this device must accept any interference received, including interference that may cause undesired operation.

This equipment has been tested and found to comply with the limits for a Class B digital device, pursuant to Part 15 of the FCC Rules. These limits are designed to provide reasonable protection against harmful interference in a residential installation. This equipment generates, uses, and can radiate radio frequency energy and, if not installed and used in accordance with the instructions, may cause harmful interference to radio communications. However, there is no guarantee that interference will not occur in a particular installation. If this equipment does cause harmful interference to radio or television reception, which can be determined by turning the equipment off and on, the user is encouraged to try to correct the interference by one or more of the following measures:

- Reorient or relocate the receiving antenna.
- Increase the separation between the equipment and receiver.
- Connect the equipment into an outlet on a circuit different from that to which the receiver is connected.
- Consult the dealer or an experienced radio/TV technician for help.

You are cautioned that any changes or modifications not expressly approved in this manual could void your authority to operate this equipment.

Disposal of Used Lamp

This projector's lamp contains mercury and should be disposed of properly. Consult your local authorities regarding safe disposal. The material contained in this lamp are similar to those of a fluorescent lamp, so you should dispose of it in the same way.

For customers in the United States

Lamp in this product contains mercury. Disposal of these materials may be regulated due to environmental considerations. For disposal or recycling information, please contact your local authorities or the Electronic Industries Alliance (www.eiae.org).

Trademark Information

"BRAVIA" and BRAVIA are trademarks of Sony Corporation.

HDMI, the HDMI logo and High-Definition Multimedia Interface are trademarks or registered trademarks of HDMI Licensing LLC.

For customers in Canada

This Class B digital apparatus complies with Canadian ICES-003.

Voor de klanten in Nederland

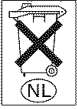

Gooi de batterij niet weg maar lever deze in als klein chemisch afval (KCA).

The socket-outlet should be installed near the equipment and be easily accessible.

CAUTION

RISK OF EXPLOSION IF BATTERY IS REPLACED BY AN INCORRECT TYPE.
DISPOSED OF USED BATTERIES ACCORDING TO THE LOCAL RULES.

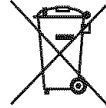

Disposal of Old Electrical & Electronic Equipment (Applicable in the European Union and other European countries with separate collection systems)

This symbol on the product or on its packaging indicates that this product shall not be treated as household waste. Instead it shall be handed over to the applicable collection point for the recycling of electrical and electronic equipment. By ensuring this product is disposed of correctly, you will help prevent potential negative consequences for the environment and human health, which could otherwise be caused by inappropriate waste handling of this product. The recycling of materials will help to conserve natural resources. For more detailed information about recycling of this product, please contact your local Civic Office, your household waste disposal service or the shop where you purchased the product.

For customers in Taiwan only



廢電池請回收
僅適用於台灣

Table of Contents

| | |
|-------------------|---|
| Precautions | 7 |
|-------------------|---|

| | |
|--|---|
| Checking the model name of the projector | 7 |
|--|---|

Location of Controls

| | |
|------------------|---|
| Front/Side | 8 |
|------------------|---|

| | |
|-------------------|---|
| Rear/Bottom | 9 |
|-------------------|---|

| | |
|----------------------|----|
| Remote Control | 10 |
|----------------------|----|

Connections and Preparations

| | |
|-----------------|----|
| Unpacking | 11 |
|-----------------|----|

| | |
|--|----|
| Step 1: Installing the Projector | 12 |
|--|----|

| | |
|---------------------------------------|----|
| Before Setting Up the Projector | 12 |
|---------------------------------------|----|

| | |
|--|----|
| Positioning the Projector and a screen | 14 |
|--|----|

| | |
|--|----|
| Step 2: Connecting the Projector | 17 |
|--|----|

| | |
|---------------------------|----|
| Connecting to a VCR | 17 |
|---------------------------|----|

| | |
|--------------------------------|----|
| Connecting to a Computer | 20 |
|--------------------------------|----|

| | |
|--|----|
| Step 3: Adjusting the Picture Position | 21 |
|--|----|

| | |
|---|----|
| Step 4: Selecting the Menu Language | 25 |
|---|----|

Projecting

| | |
|--|----|
| Projecting the Picture on the Screen | 27 |
|--|----|

| | |
|-----------------------------|----|
| Turning Off the Power | 28 |
|-----------------------------|----|

| | |
|-------------------------------------|----|
| Selecting the Wide Screen Mode | 28 |
|-------------------------------------|----|

| | |
|--|----|
| Selecting the Picture Viewing Mode | 31 |
|--|----|

| | |
|-------------------------------------|----|
| Adjusting the Picture Quality | 32 |
|-------------------------------------|----|

| | |
|---|----|
| Adjusting the Picture Using Real Color Processing (VPL-AW15 only) | 33 |
|---|----|

| | |
|-----------------------------|----|
| Using Other Functions | 35 |
|-----------------------------|----|

Using the Menus

| | |
|-----------------------------------|----|
| Operation through the Menus | 36 |
|-----------------------------------|----|

| | |
|--------------------|----|
| Picture Menu | 40 |
|--------------------|----|

| | |
|---|----|
| Advanced Picture Menu (VPL-AW15 only) | 43 |
|---|----|

| | |
|-------------------|----|
| Screen Menu | 44 |
|-------------------|----|

| | |
|------------------|----|
| Setup Menu | 46 |
|------------------|----|

| | |
|---------------------|----|
| Function Menu | 48 |
|---------------------|----|

| | |
|-------------------------|----|
| Installation Menu | 49 |
|-------------------------|----|

| | |
|------------------------|----|
| Information Menu | 50 |
|------------------------|----|

| | |
|----------------------------------|----|
| About the Preset Memory No. | 50 |
|----------------------------------|----|

Others

| | |
|---|----|
| Troubleshooting | 51 |
| Warning Indicators | 53 |
| Message Lists | 54 |
| Replacing the Lamp and the Air Filter and cleaning the Ventilation holes (intake) | 55 |
| Replacing the Air Filter | 58 |
| Fitting the lens cap | 58 |
| Specifications | 59 |
| Preset Signals | 61 |
| Input Signals and Adjustable/ Setting Items | 64 |
| Ceiling Installation | 66 |
| When Using the PSS-H10 Projector Suspension Support | 66 |
| When Using the PSS-610 Projector Suspension Support | 70 |
| Index | 73 |

Precautions

On safety

- Check that the operating voltage of your unit is identical with the voltage of your local power supply.
- Should any liquid or solid object fall into the cabinet, unplug the unit and have it checked by qualified personnel before operating it further.
- Unplug the unit from the wall outlet if it is not to be used for several days.
- To disconnect the cord, pull it out by the plug. Never pull the cord itself.
- The wall outlet should be near the unit and easily accessible.
- The unit is not disconnected to the AC power source (mains) as long as it is connected to the wall outlet, even if the unit itself has been turned off.
- Do not look into the lens while the lamp is on.
- Do not place your hand or objects near the ventilation holes. The air coming out is hot.

On preventing internal heat build-up

After you turn off the power with the I/⏻ (On/standby) switch, do not disconnect the unit from the wall outlet while the cooling fan is still running.

Caution

The projector is equipped with ventilation holes (intake) and ventilation holes (exhaust). Do not block or place anything near these holes, or internal heat build-up may occur, causing picture degradation or damage to the projector.

On repacking

Save the original shipping carton and packing material; they will come in handy if you ever have to ship your unit. For maximum protection, repack your unit as it was originally packed at the factory.

Checking the model name of the projector

Check the model name of the projector first. The model name is located at the bottom of the projector (Example: VPL-AW15). You cannot use some of the functions or menu options for certain projector models.

Location of Controls

Front/Side

You can use the buttons on the control panel with the same names as those on the remote control to operate the projector.

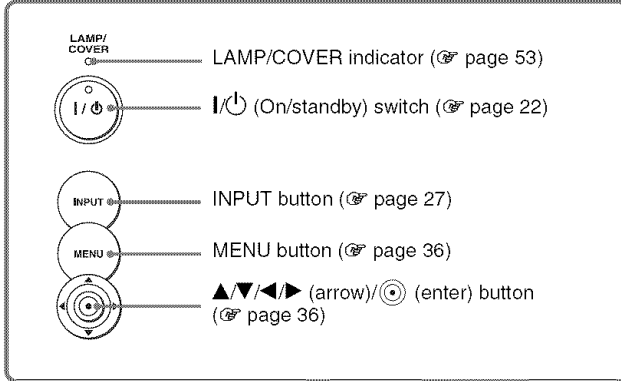

Note

While the I/⏻ (On/standby) indicator lights in orange, the power saving mode is on. (page 46)

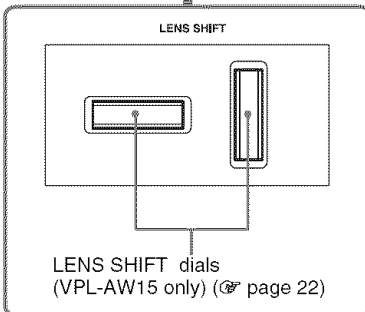
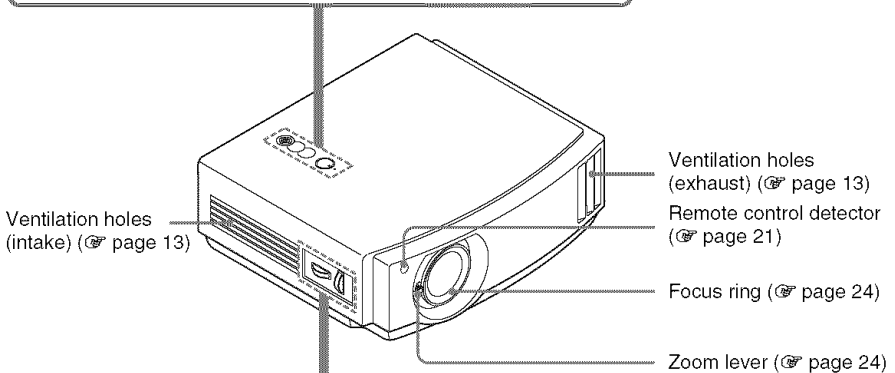

Rear/Bottom

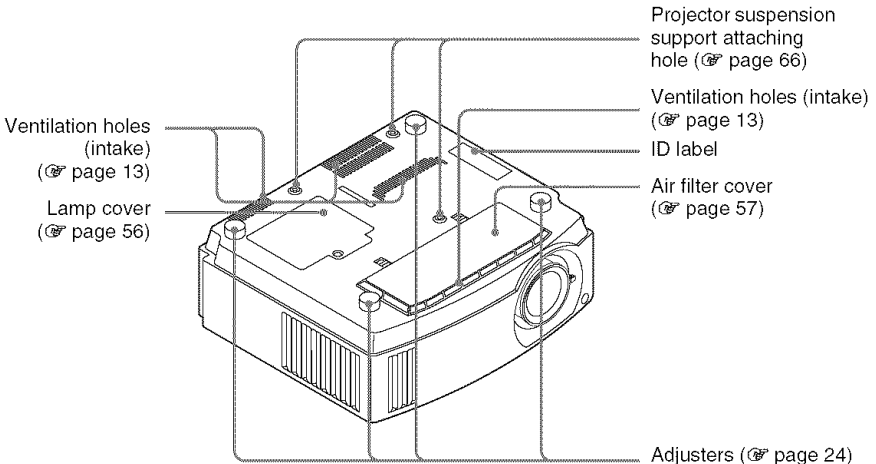
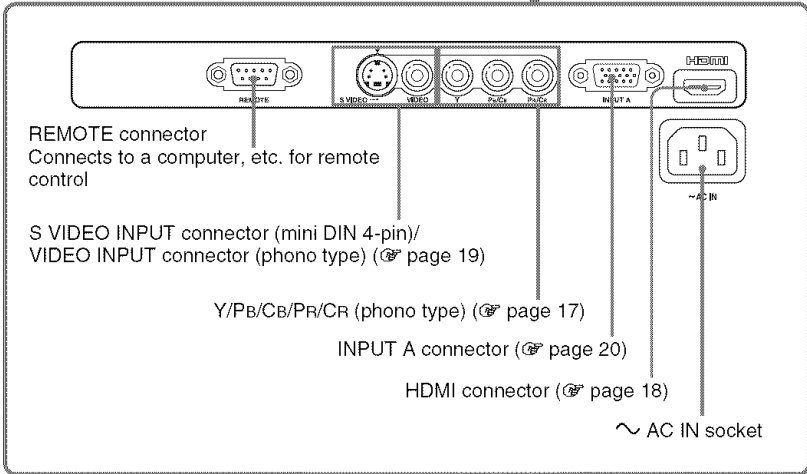
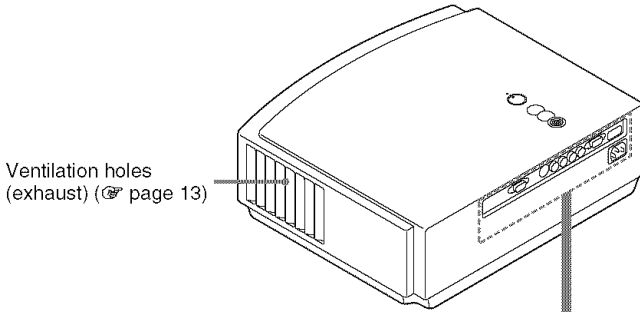

Remote Control

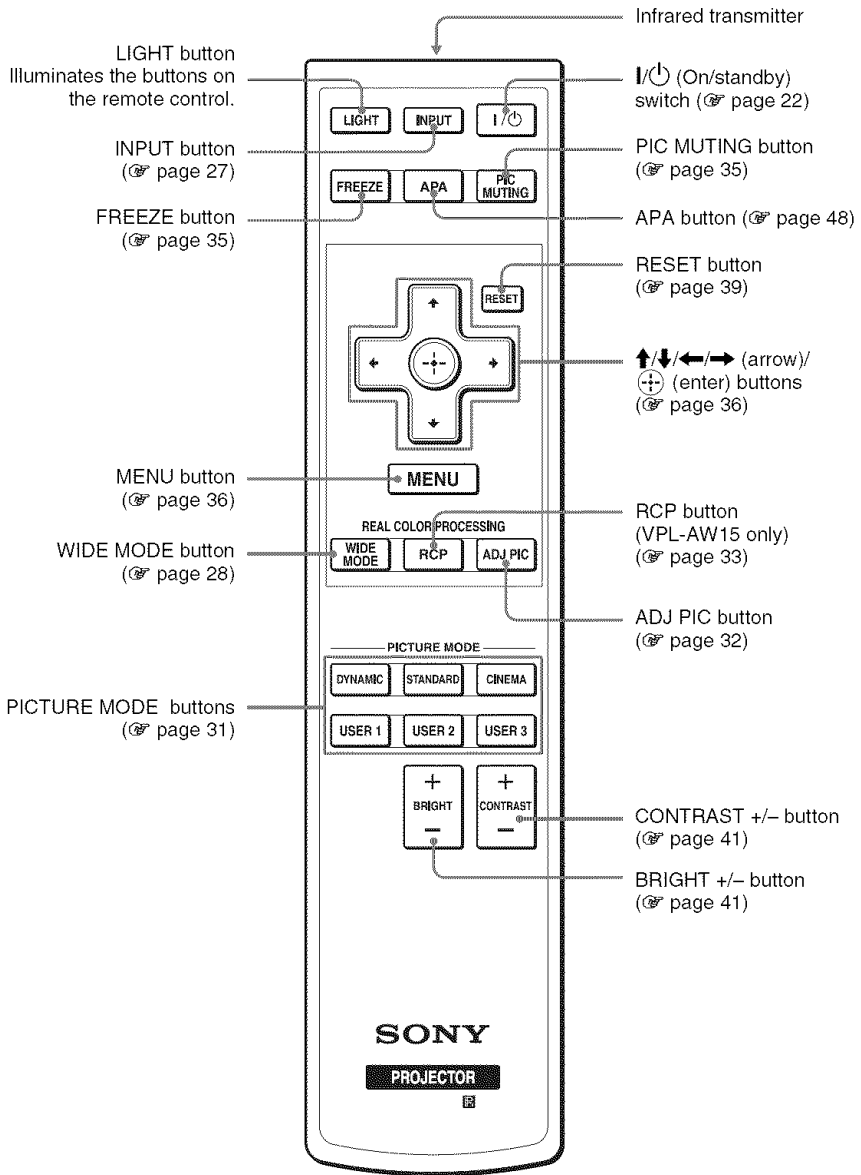

Connections and Preparations

This section describes how to install the projector and screen, how to connect the equipment from which you want to project the picture, etc.

Unpacking

Check the carton to make sure it contains the following items:

- Remote control (1) and Size AA (R6) batteries (2)
- Lens cap (1)
When you have purchased the projector, the lens cap was fitted onto the lens. Remove this lens cap when you use the projector.
- Operating Instructions (this manual)

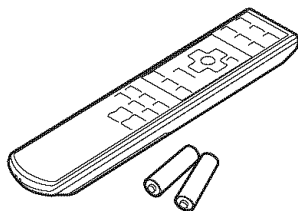

- AC power cord (1)
- Air filter (for replacement) (1)

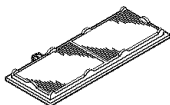

Inserting the batteries into the remote control

Push and slide to open.

Insert the batteries  side first as shown in the illustration. Inserting them forcibly or with the polarities reversed may cause a short circuit and may generate heat.

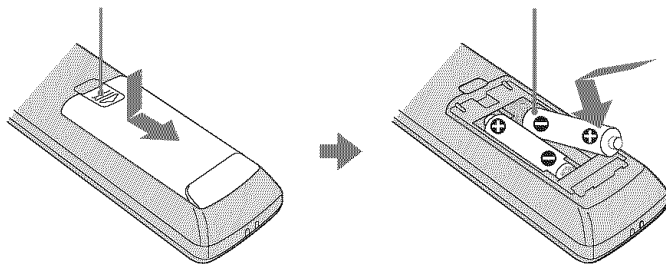

Step 1: Installing the Projector

The projector displays pictures output from a VCR or other devices.

The projector can be used in various places and you can enjoy viewing beautiful pictures easily.

Before Setting Up the Projector

Unsuitable installation

Do not place the projector in the following situations, which may cause malfunction or damage to the projector.

Poorly ventilated location

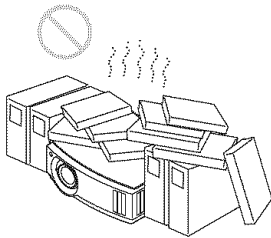

Hot and humid

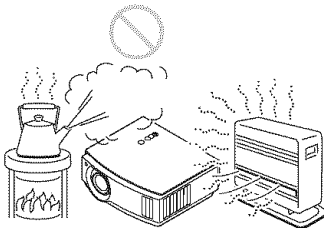

Locations subject to direct cool or warm air from an air-conditioner

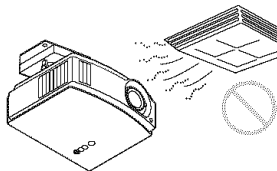

Installing the projector in such a location may cause a malfunction of the unit due to moisture condensation or rise in temperature.

Near a heat or smoke sensor

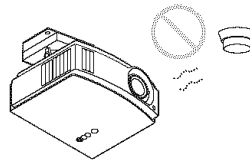

Malfunction of the sensor may occur.

Very dusty and extremely smoky locations

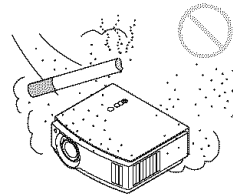

Install in a location away from walls

Allow at least 30 cm (11 7/8 inches) between the projector and walls.

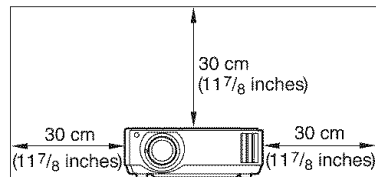

Improper use

Do not do any of the following while using the projector.

Blocking the ventilation holes.

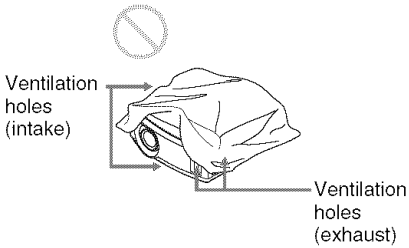

Tip

For details on the location of the ventilation holes (intake or exhaust), see “Location of Controls” on pages 8 to 9.

Tilting front/rear and left/right

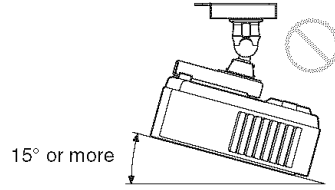
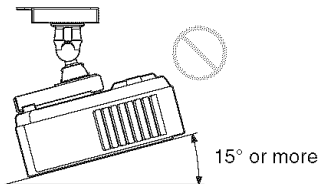
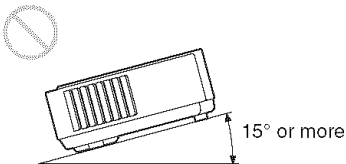
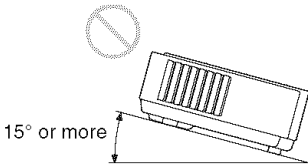
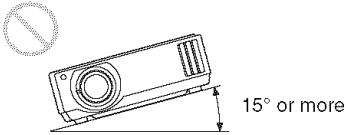

Avoid using the projector tilted at an angle of more than 15 degrees.

Do not install the projector anywhere other than on a level surface or on the ceiling. Failing to set this mode when using the projector at high altitudes may result in uneven color uniformity and reducing the reliability of the effects of the lamp.

When installing the unit at altitudes

When using the projector at an altitude of 1,500 m or higher, set “Cooling Setting” in the Setup menu to “High” (☞ page 46). Failing to set this mode when using the projector at high altitudes could have adverse effects, such as reducing the reliability of certain components.

Positioning the Projector and a screen

The installation distance between the projector and a screen varies depending on the size of the screen.

1 Determine the installation position of the projector and screen.

You can obtain a good quality picture if you position the projector with the center of the lens within the areas indicated in the gray areas in the illustration (VPL-AW15 only). Use the values a, b, c and d in the table on page 15 as a guide.

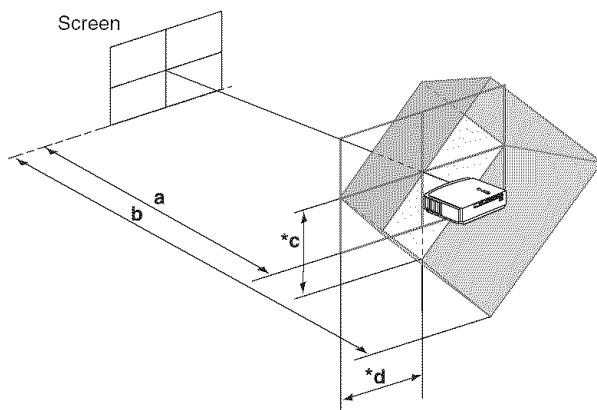

- a:** Minimum projection distance between the screen and the center of the projector's lens
- b:** Maximum projection distance between the screen and the center of the projector's lens

(VPL-AW15 only)

- *c:** Vertical distance between the center of the screen and the center of the projector's lens when using the maximum upper vertical lens shift feature
- *d:** Horizontal distance between the center of the screen and the center of the projector's lens when using the maximum horizontal lens shift feature
- * The distances c and d indicated in the illustration show those in the lower or left direction. The same distances in the upper or right direction are appropriate for installation.

- ◆ For installation of the projector on a ceiling, see “Ceiling Installation.” (📄 page 66)
- ◆ For details on the lens shift feature, see “Step 3: Adjusting the Picture Position.” (📄 page 21)

When using the 16:9 aspect ratio screen

Unit: mm (inches)

| Screen size (inches) | 40 | 60 | 70 | 80 | 100 | 120 | 140 | 160 | 180 | 200 |
|----------------------|---|--|---|--|--|--|--|--|--|--|
| (mm) | 1016 | 1524 | 1778 | 2032 | 2540 | 3048 | 3556 | 4064 | 4572 | 5080 |
| a (minimum) | 1151 (45 ³ / ₈) | 1750 (69) | 2049 (80 ¹¹ / ₁₆) | 2348 (92 ¹ / ₂) | 2946 (116) | 3544 (139 ⁵ / ₈) | 4142 (163 ¹ / ₈) | 4740 (186 ³ / ₄) | 5339 (210 ¹ / ₄) | 5937 (233 ⁷ / ₈) |
| b (maximum) | 1885 (74 ¹ / ₄) | 2849 (112 ¹ / ₄) | 3332 (131 ¹ / ₄) | 3814 (150 ¹ / ₄) | 4779 (188 ¹ / ₄) | 5744 (226 ¹ / ₄) | 6709 (264 ¹ / ₄) | 7673 (302 ¹ / ₈) | 8638 (340 ¹ / ₈) | 9603 (378 ¹ / ₈) |
| *c | 324 (12 ³ / ₄) | 485 (19 ¹ / ₈) | 566 (22 ³ / ₈) | 647 (25 ¹ / ₂) | 809 (31 ⁷ / ₈) | 971 (38 ¹ / ₄) | 1133 (44 ³ / ₈) | 1294 (51) | 1456 (57 ³ / ₈) | 1618 (63 ³ / ₄) |
| *d | 221 (8 ³ / ₄) | 331 (13 ¹ / ₈) | 387 (15 ¹ / ₄) | 442 (17 ¹ / ₂) | 552 (21 ³ / ₄) | 663 (26 ¹ / ₈) | 773 (30 ¹ / ₂) | 884 (34 ⁷ / ₈) | 994 (39 ¹ / ₄) | 1105 (43 ¹ / ₂) |

To calculate the installation measurements (SS: Screen Size)

a (minimum) = $29.909 (1 \frac{3}{16}) \times SS - 44.886 (1 \frac{13}{16})$

b (maximum) = $48.239 (1 \frac{1}{16}) \times SS - 44.869 (1 \frac{13}{16})$

c = $8.0899 (1 \frac{11}{32}) \times SS$

d = $5.5245 (7 \frac{1}{32}) \times SS$

*VPL-AW15 only

When using the 4:3 aspect ratio screen (projecting a 4:3 picture)

Unit: mm (inches)

| Screen size (inches) | 40 | 60 | 70 | 80 | 100 | 120 | 140 | 160 | 180 | 200 |
|----------------------|---|--|---|--|--|--|--|--|---|---|
| (mm) | 1016 | 1524 | 1778 | 2032 | 2540 | 3048 | 3556 | 4064 | 4572 | 5080 |
| a (minimum) | 1419 (56) | 2152 (84 ³ / ₄) | 2518 (99 ¹ / ₄) | 2884 (113 ⁵ / ₈) | 3616 (142 ¹ / ₂) | 4348 (171 ¹ / ₄) | 5080 (200 ¹ / ₈) | 5813 (228 ⁷ / ₈) | 6545 (257 ³ / ₄) | 7277 (286 ⁵ / ₈) |
| b (maximum) | 2317 (91 ¹ / ₄) | 3498 (137 ³ / ₄) | 4088 (161) | 4679 (184 ¹ / ₄) | 5860 (230 ³ / ₄) | 7041 (277 ¹ / ₄) | 8221 (323 ³ / ₄) | 9402 (370 ¹ / ₄) | 10583 (416 ³ / ₄) | 11764 (463 ¹ / ₄) |
| *c | 396 (15 ⁵ / ₈) | 594 (23 ¹ / ₂) | 693 (27 ³ / ₈) | 792 (31 ¹ / ₄) | 990 (39) | 1188 (46 ⁷ / ₈) | 1386 (54 ³ / ₈) | 1584 (62 ¹ / ₂) | 1782 (70 ¹ / ₄) | 1980 (78) |
| *d | 270 (10 ³ / ₄) | 406 (16) | 473 (18 ³ / ₄) | 541 (21 ³ / ₈) | 676 (26 ⁵ / ₈) | 811 (32) | 947 (37 ³ / ₈) | 1082 (42 ⁵ / ₈) | 1217 (48) | 1352 (53 ³ / ₈) |

To calculate the installation measurements (SS: Screen Size)

a (minimum) = $36.609 (1 \frac{1}{2}) \times SS - 44.886 (1 \frac{13}{16})$

b (maximum) = $59.045 (2 \frac{3}{8}) \times SS - 44.869 (1 \frac{13}{16})$

c = $9.902 (1 \frac{13}{32}) \times SS$

d = $6.762 (9 \frac{1}{32}) \times SS$

*VPL-AW15 only

2 Position the projector so that the lens is parallel to the screen.

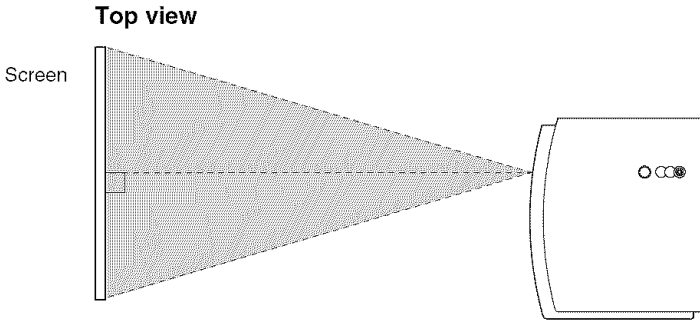

3 Project an image on the screen and adjust the picture so that it fits the screen. (☞ page 21)

To project an image, connect video equipment to the projector. (☞ page 17)

Note

When using a screen with an uneven surface, stripes pattern may rarely appear on the screen depending on the distance between the screen and the projector or the zooming magnifications. This is not a malfunction of the projector.

Step 2: Connecting the Projector

When making connections, be sure to do the following:

- Turn off all equipments before making any connections.
- Use the proper cables for each connection.
- Insert the cable plugs properly; poor connection at the plugs may cause a malfunction or poor picture quality. When pulling out a cable, be sure to pull it out with holding the plug, not the cable itself.
- Refer to the operating instructions of the connected equipment.

Connecting to a VCR

To connect to a DVD player/recorder, Blu-ray Disc player or digital tuner equipped with component video connectors

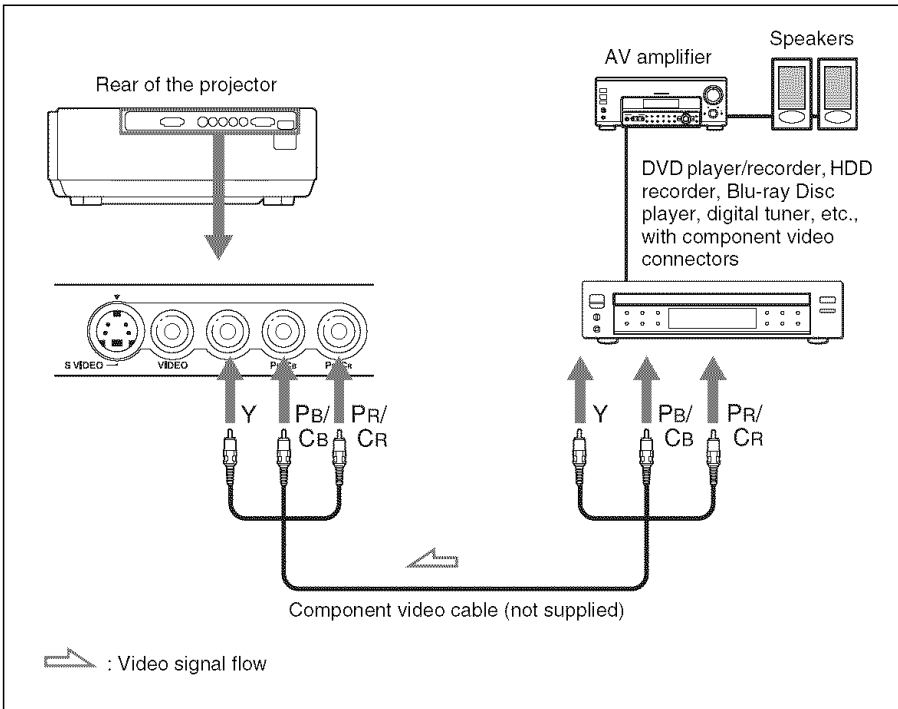

To connect to a DVD player/recorder and Blu-ray Disc player equipped with HDMI output

You can enjoy better picture quality by connecting a DVD player/recorder and Blu-ray Disc player equipped with HDMI output to the HDMI input of the projector.

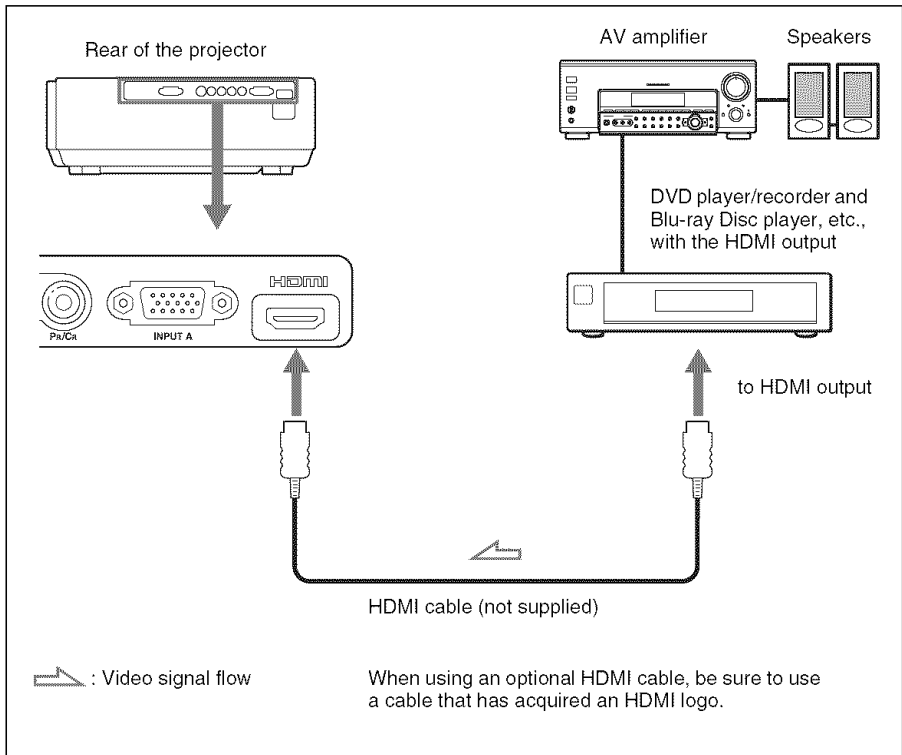

.....
This projector supports PC display input that has been available since Ver.1.2a of HDMI standards. It also supports HDCP.

To connect to a VCR equipped with the S video connector or video connector

You can connect a DVD player/recorder, hard disk video recorder, VCR or laser disk player, which is not equipped with component video connectors. See also the instruction manual of each equipment.

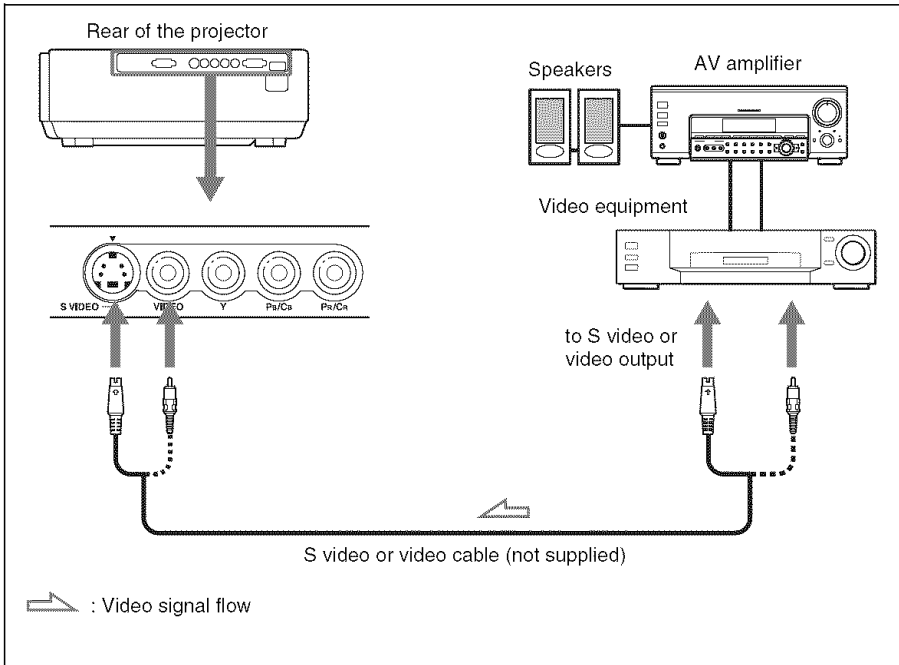

Tip



In order to enjoy better video performance, use S Video connector.

If the equipment to be connected has no S video connector, connect the cable to the video output.

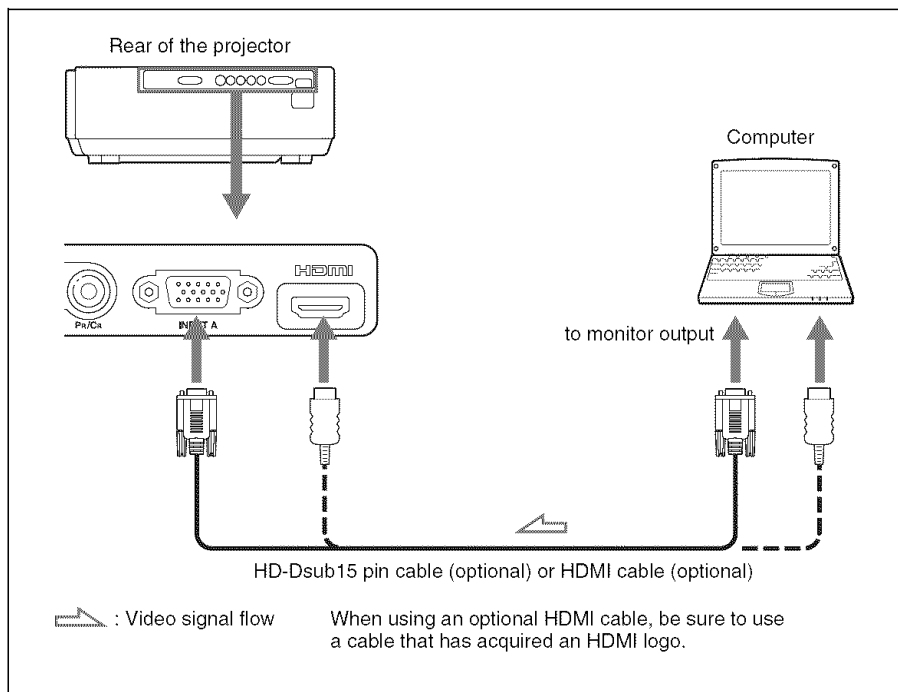
Connecting to a Computer



Tip

Set "Input-A Signal Sel." in the Setup  menu to "Auto" or "Computer." If the input signal does not appear properly, set it to "Computer." ( page 47, 54)

Note

If you set your computer, such as a notebook type, to output the signal to both computer's display and this equipment, the picture of the equipment may not appear properly. Set your computer to output the signal to only the external monitor.

For details, refer to the computer's operating instructions supplied with your computer.

Step 3: Adjusting the Picture Position

Project an image on the screen and then adjust the picture position.

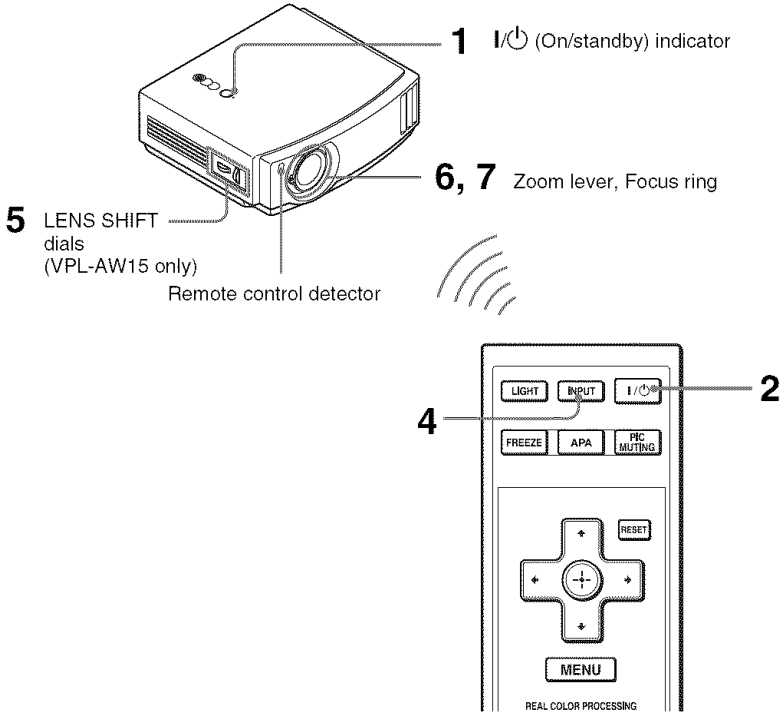

Tip

The I/⏻ (On/standby), INPUT, MENU, and ▲/▼/◀/▶/⊙ (joystick) buttons on the top panel of the projector function the same as those on the remote control.

Note

Depending on the installation location of the projector, you may not control it with the remote control. In this case, point the remote control to the screen instead of the projector.

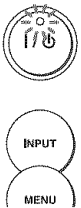

- 1** After connecting the AC cord to the equipment, plug the AC cord into a wall outlet.

The I/⏻ (On/standby) indicator lights in red and the projector goes into standby mode.

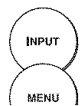
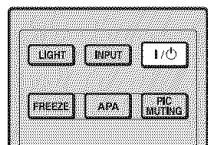

Flashes in green for a few seconds, and then lights in green.

2 Press the I/⏻ (On/standby) switch to turn on the projector.

The I/⏻ (On/standby) indicator flashes in green, and then lights in green.

3 Turn on the equipment connected to the projector.

Refer to the operating instructions of the connected equipment.

4 Press INPUT to project the picture on the screen.

Each time you press the button, the input indication and equipment to be projected change. (☞ page 27)

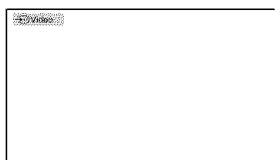
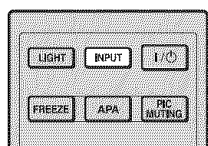

Tips

- You can select the desired language for the menu screen. For details, refer to "Step 4: Selecting the Menu Language". (☞ page 25)
- When "Auto Input Search" is set to "On" in the Function  menu, the input terminal with effective signals is automatically displayed by pressing INPUT. (☞ page 48)

5 Move both LENS SHIFT dials (VPL-AW15 only) to adjust the picture position.

(VPL-AW15 only)

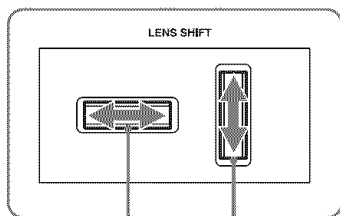

To adjust the horizontal position

To adjust the vertical position

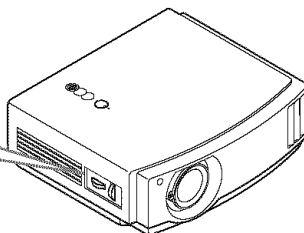

To adjust the horizontal position

Turn the LENS SHIFT dial right or left.

The picture projected on the screen moves right or left by a maximum of 25% of the screen size from the center of the lens.

25% 1 screen width 25%

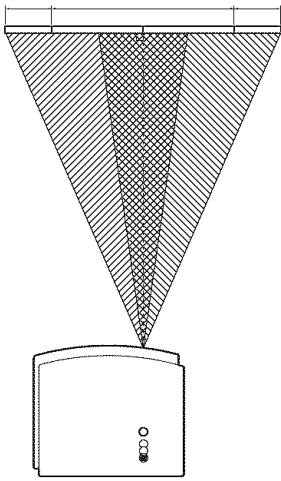

Top view

- : Picture position when moving the picture to the left at maximum
- : Picture position when moving the picture to the right at maximum

To adjust the vertical position

Turn the LENS SHIFT dial up or down.

The picture projected on the screen moves up or down by a maximum of 65% of the screen size from the center of the lens.

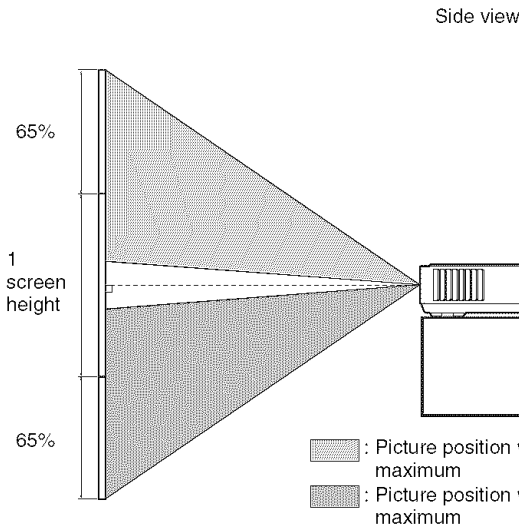

Side view

- : Picture position when moving the picture upward at maximum
- : Picture position when moving the picture downward at maximum

Note

When you use both the horizontal and vertical lens shift features at the same time, you can move the picture vertically by a maximum of 25% of the screen size.

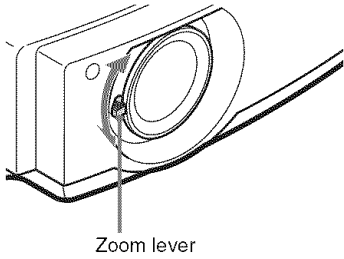

6 Adjust the picture size using the zoom lever.

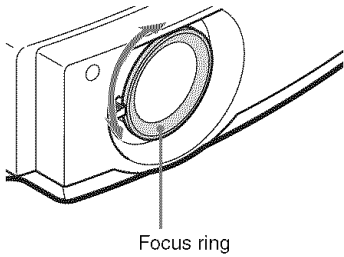

7 Adjust the focus using the focus ring.

To adjust the tilt of the installation surface

If the projector is installed on an uneven surface, use the adjusters to keep the projector level.

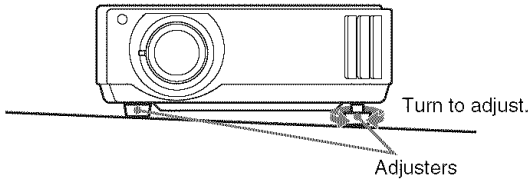

Note

Be careful not to catch your finger when turning the adjusters.

Step 4: Selecting the Menu Language

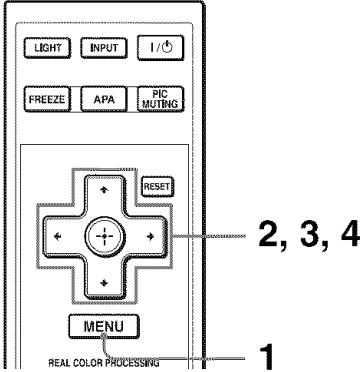

You can select one of 16 languages for displaying the menu and other on-screen displays. The factory default setting is English. To change the current menu language, set the desired language with the menu screen.



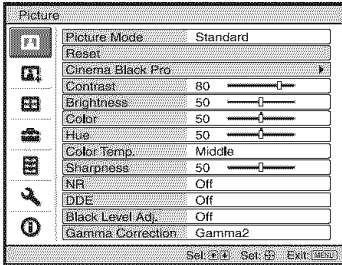
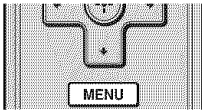

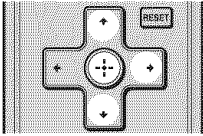
- 1 Press MENU.**
The menu appears.





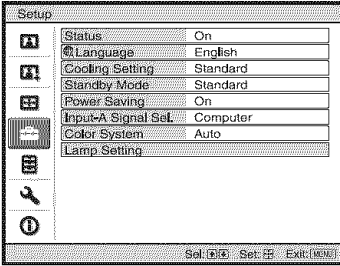

- 2** Press **↑/↓** to select the Setup  menu, and press **→** or .
- The setting items of the selected menu appears.

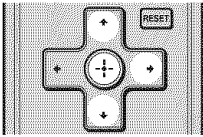

- 3** Press **↑/↓** to select “Language,” and press **→** or .



- 4** Press **↑/↓/←/→** to select a language, and press .
- The menu changes to the selected language.

To clear the menu

Press MENU.

Projecting

This section describes how to operate the projector to view the picture from the equipment connected to the projector. It also describes how to adjust the quality of the picture to suit your taste.

Projecting the Picture on the Screen

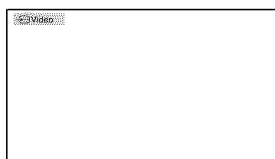
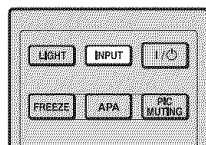

Example: To view the picture from the video equipment connected to the VIDEO INPUT connector.

- 1 Power on both the equipment and the device connected to the equipment.**
- 2 Press INPUT repeatedly to select the input you want to project on the screen.**
Display the indication of the input you want.

| To view the picture from | Press INPUT to display |
|--|------------------------|
| Video equipment connected to the VIDEO INPUT connector | Video |
| Video equipment connected to S VIDEO INPUT connector | S-Video |
| RGB/component equipment connected to the INPUT A connector | Input-A* |
| Component equipment connected to Y/PB/CB/PR/CR connectors | Component |
| Equipment connected to the HDMI connector | HDMI** |

* Set the "Input-A Signal Sel." setting in the Setup  menu according to the signal input. When you set it to "Auto," and cannot display the picture properly, select an appropriate signal according to the input signal. (🔍 page 47, 50, 61)

** The color gradation of the dark area or the bright area may become unclear when a signal other than those from HDMI standard cable is input. Adjust the Brightness and the Contrast in the Picture  menu. (🔍 page 41)

Tip

When "Auto Input Search" is set to "On" in the Function  menu, the input terminal with effective signals is automatically displayed by pressing INPUT.

Turning Off the Power

1 Press the I/⏻ (On/standby) switch.

A message “POWER OFF?” appears on the screen.

2 Press the I/⏻ (On/standby) switch again before the message disappears.

The I/⏻ (On/standby) indicator flashes in green and the fan continues to run to reduce the internal heat. First, the I/⏻ (On/standby) indicator flashes quickly, during which you will not be able to light up the I/⏻ (On/standby) indicator with the I/⏻ (On/standby) switch.

3 Confirm that the fan stops running and the I/⏻ (On/standby) indicator lights in red.

You can turn off the projector by holding the I/⏻ (On/standby) switch for about 1 second, instead of performing the above steps.

Selecting the Wide Screen Mode

You can enjoy various wide screen modes according to the video signal received.

Press WIDE MODE.

Each time you press the button, you can change the “Wide Mode” setting in turn.

You can also select it using the menu. (☞ page 44)

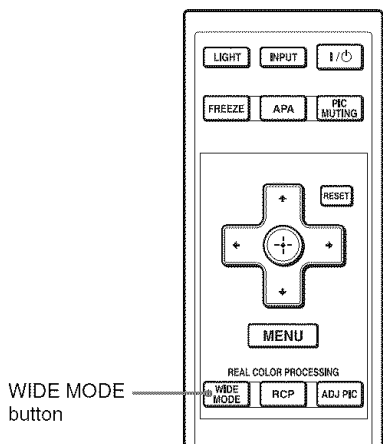

* RCP button: VPL-AW15 only

Original image

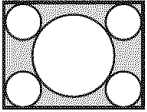

When the Wide Mode is operated

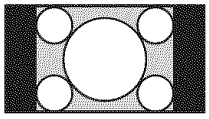
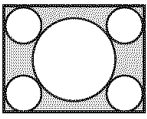
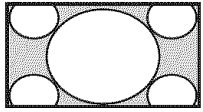

Squeezed

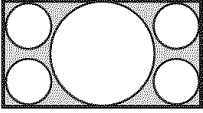
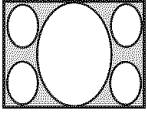

Letterbox picture with side panels

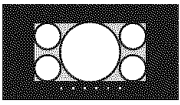

Letterbox picture

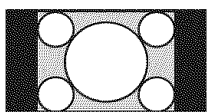
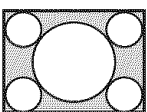
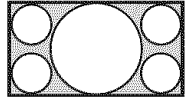
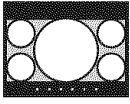

Wide Zoom

A 4:3 aspect ratio picture is enlarged over the entire screen properly. The upper and lower portions of the screen are slightly cut off.

Normal

A picture with normal 4:3 aspect ratio is displayed in the center of the screen to fill the vertical screen size.

Full

A picture squeezed to 4:3 is displayed with the correct aspect ratio. A 4:3 picture is enlarged horizontally to fit the 16:9 screen.

Tip

Squeezed: An original 16:9 aspect ratio picture is recorded horizontally compressed to a 4:3 picture.

Zoom

A normal 16:9 aspect ratio picture is enlarged vertically and horizontally in the same ratio to fill the screen. Use this mode to view a letterbox picture or a letterbox picture with side panels.

If the subtitle of a movie, etc. is hidden and cannot be seen, adjust the screen with "Vertical Size" and "V Center" to display the subtitle. (☞ page 45)

Full 1 (When the PC signal is input)

Displays a picture on the whole of the screen without changing the aspect ratio of the original picture.

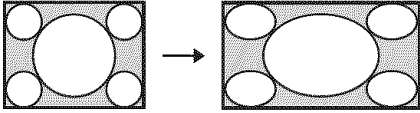

Full 2 (When the PC signal is input)

Displays a picture on the whole of the screen.

Note

You can adjust the vertical position of the picture with “V Center” and “Vertical Size” in the Screen  menu only when “Zoom” is selected. (☞ page 45)

Notes on selecting the wide screen mode

The projector is featured with the WIDE MODE. When changing the settings of WIDE MODE, it must be noted as below.

- Changing the aspect ratio of the original picture will provide a different look from that of the original image.
- Note that if the projector is used for profit or for public viewing, modifying the original picture by switching to the wide mode may constitute an infringement of the rights of authors or producers, which are legally protected.

Selecting the Picture Viewing Mode

You can select the picture viewing mode that best suits the type of program or room conditions.

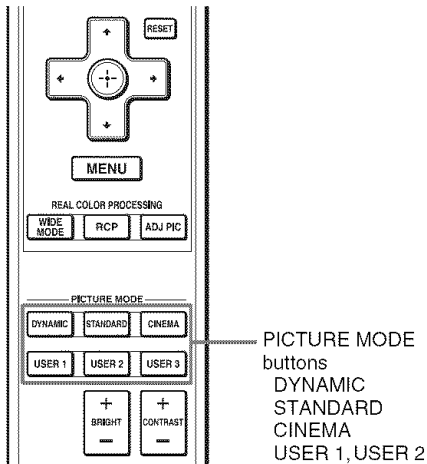

* RCP button:
VPL-AW15 only

PICTURE MODE
buttons
DYNAMIC
STANDARD
CINEMA
USER 1, USER 2
and USER 3

Press one of the **PICTURE MODE** buttons (**DYNAMIC**, **STANDARD**, **CINEMA** and **USER 1**, **USER 2** and **USER 3**).

DYNAMIC

Enhances picture contrast and sharpness.

STANDARD

The quality of the picture becomes less rough than the one selected by "DYNAMIC".

CINEMA

Recommended when viewing a movie in the dark place.

USER 1, USER 2 and USER 3

You can adjust the quality of the picture to suit your taste and store the settings into the selected memory of the projector. Press one of the USER 1, USER 2 and USER 3 buttons, then adjust the picture by using the buttons on the remote control or the menus (pages 32 and 40). The settings are stored, and you can view the picture with the adjusted picture quality by pressing the button.

Adjusting the Picture Quality

You can adjust the picture quality that suits your taste by selecting the adjustment items with the remote control. The adjusted data can be stored in each picture mode.

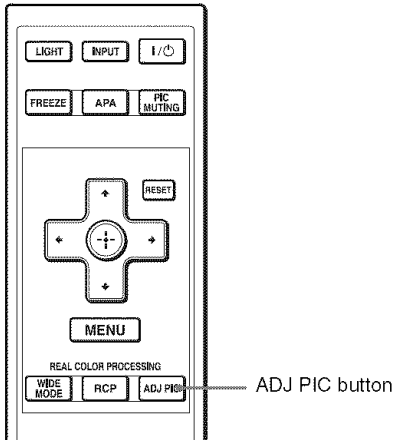

* RCP button: VPL-AW15 only

1 Press ADJ PIC.

Each time you press the button, the following adjustment windows* are displayed in sequence.

* Some of the above adjustment windows will not be displayed depending on the input signal. For details, see "Input Signals and Adjustable/Setting Items." (page 64)

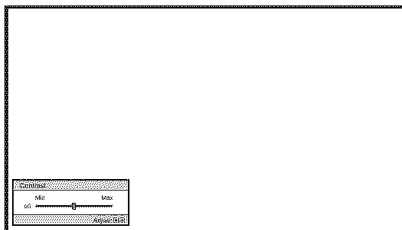
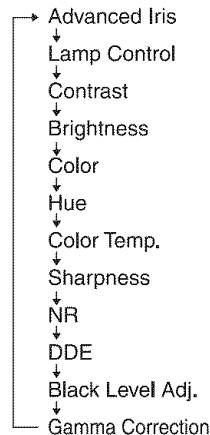

Example: To adjust the contrast

For details on each adjustment, see the Picture  menu. (page 40)

2 Make the setting or adjustment on an item.

When changing the adjustment level

To increase the value, press **→**.

To decrease the value, press **←**.

When changing the setting

Press **↑/↓** to change the setting.

Adjusting the Picture Using Real Color Processing (VPL-AW15 only)

The Real Color Processing (RCP) feature allows you to adjust the color and hue of each target of the projected picture you specify independently. You can thus obtain a picture more suitable to your taste.

Tip

Freeze the scene of the video source when you are adjusting the picture using Real Color Processing.

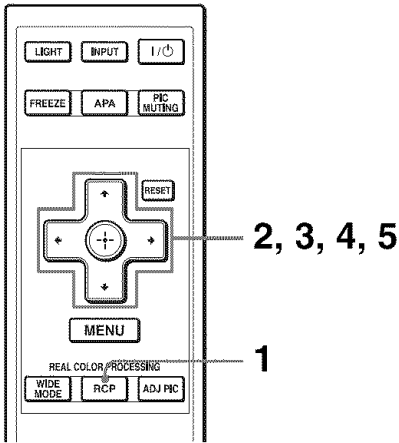

- 1** Press RCP on the remote control.
- 2** Press **↑/↓** to select “User 1,” “User 2” or “User 3,” then press **→**.
The RCP (Real Color Processing) window appears.
- 3** Select the target color you want to adjust.

Repeat steps **1** and **2** described below to specify the target color.

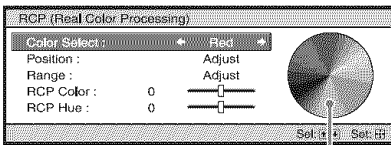

Reference palette

- 1** Press **↑/↓** to select “Color Select,” then press **←/→** to select the color you want to adjust among “Red,” “Yellow,” “Green,” “Cyan,” “Blue” and “Magenta.”

Only the portions that correspond to the specified color will be colored and the other portions will be displayed in black and white. The reference palette in the RCP window also shows the adjustable colors. Select the desired setting to adjust the color on the projected image using the reference palette as a guide.

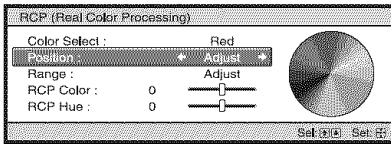

- 2 Press \uparrow/\downarrow to select “Position” or “Range,” and specify it more delicate color position and color range you want to adjust using \leftarrow/\rightarrow .

4 Adjust the color of the specified portions.

Press \uparrow/\downarrow to select “RCP Color” or “RCP Hue,” then adjust the color or hue of the portions selected in step 3 to suit your taste using \leftarrow/\rightarrow while watching the projected picture. The picture is returned to normal color during adjustment.

5 After the adjustment is complete, press \oplus .

The RCP window disappears and the picture of step 2 is appeared. Then after a few seconds, normal picture is restored. The adjustments you have made will be reflected on the picture projected on the screen.

Tip

There are some limitations on selection of position and range.

Using Other Functions

You can temporarily turn off or pause a projected picture.

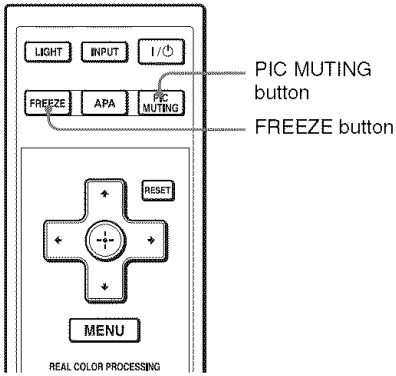

Press PIC MUTING.

Press to temporarily turn off a projected picture. To return to the previous screen, press PIC MUTING again.

Press FREEZE.

A projected picture can be paused to be displayed. "FREEZE" is shown on the screen when a button is pressed. To return to the previous screen, press FREEZE again.

Note

Available for only computer signal.

Using the Menus

This section describes how to make various adjustments and settings using the menus.

Operation through the Menu

The projector is equipped with an on-screen menu for making various adjustments and settings. Some of the adjustable/setting items are displayed in a pop-up menu, in a setting menu or adjustment menu with no main menu, or in the next menu window. If you select an item name followed by an arrow (▶), the next menu window with setting items appears. To change the on-screen menu language, see “Step 4: Selecting the Menu Language.” (📖 page 25)

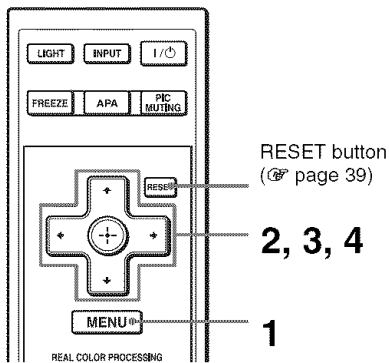

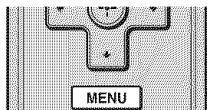

1 Press MENU.

The menu window appears.

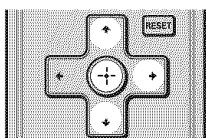
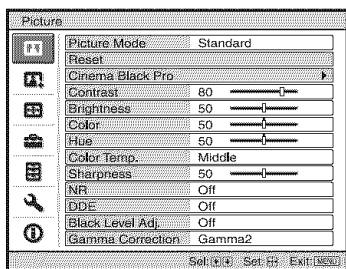

2 Press ↑/↓ to select a menu item, and press → or ⊕.

The items that can be set or adjusted with the selected menu appear. The item presently selected is shown in yellow.

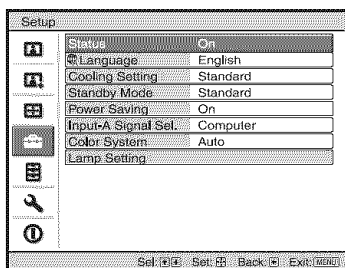

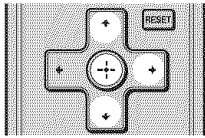

Pop-up menu

Setting items



Setting menu

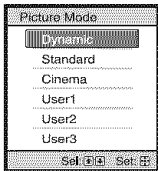

Adjustment menu

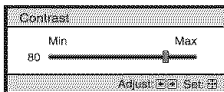

Next menu window

Setting items

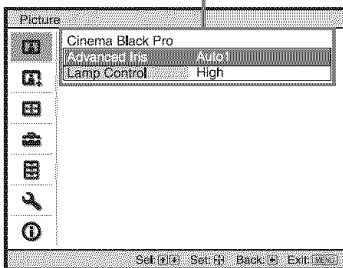

(Menu window of VPL-AW15)

- 3** Press **↑/↓** to select an item you want to set or adjust and press **→** or **⊕**.

The items that can be set appear in the pop-up menu, setting menu, adjustment menu, or in the next menu window.

4 Make the setting or adjustment of an item.

When changing the adjustment level

To increase the value, press **↑/→**.

To decrease the value, press **↓/←**.

Press **⊕** to restore the previous screen.

When changing the setting

Press **↑/↓** to change the setting.

Press **⊕** to restore the previous screen.

You can restore the previous screen using **←** depending on the selected item.

Items that cannot be adjusted

Adjustable items are limited depending on the input signals. The items that cannot be adjusted or set do not appear in the menu. (☞ page 64)

To clear the menu

Press MENU.

To reset the picture that has been adjusted

Select “Reset” from Picture **ⓘ** menu.

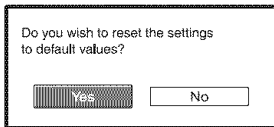

When the screen display appears, select “Yes” using **←** and press **⊕**.

All of the following settings are reset to its factory preset value.

“Advanced Iris”, “Lamp Control”, “Contrast”, “Brightness”, “Color”, “Hue”, “Color Temp”, “Sharpness”, “NR”, “DDE”, “Black Level Adj.” and “Gamma Correction” on the Picture **ⓘ** menu

To reset the items that have been adjusted

Select an item in the Menu screen, and display the pop-up menu, the setting menu, and the adjustment menu.

Press the RESET on the remote control to reset only the selected settings to its factory preset value.

Note

RESET on the remote control is available only when the adjustment menu or the setting menu is selected.

Picture Menu

The Picture menu is used for adjusting the picture.

Adjust Picture menu

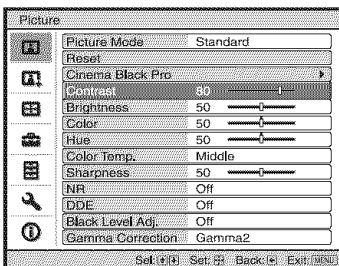
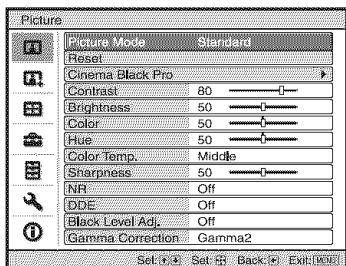

Picture Mode

You can select the picture viewing mode that best suits the type of picture or the environment.

Dynamic: Select this for enhanced picture contrast and sharpness to reproduce color tones.

Standard: Select this to reduce roughness compared to viewing the picture with Dynamic.

Cinema: Select this for watching movies, etc. in a dark environment.

User 1, User 2, User 3: You can adjust the quality of the picture to suit your taste and then store the settings. Once the settings are stored, you can view the picture with the adjusted picture quality by pressing the PICTURE MODE on the remote control.

To store the settings

- 1 Select User 1, User 2, or User 3.
- 2 Adjust the items you want in the menus.

Tip

You can also adjust the picture quality in “Dynamic”, “Standard” or “Cinema”, and store the settings. To reset everything to the factory settings, select “Reset” in the menu.

| | |
|--------------------------------|--|
| <p>Cinema Black Pro</p> | <p>Advanced Iris Switches the iris function during projection. VPL-AW15 Auto 1: Automatically switches to an optimum iris according to a projected scene. The contrast of the scene is emphasized most. Auto 2: An optimum iris becomes smaller than when set to "Auto 1". The contrast of the scene becomes reduced. Sensitivity: If "Auto1" or "Auto2" is selected, either "Recommend", "Fast", or "Slow" can be selected according to the desired response speed with Sensitivity Mode. Manual: Manually adjusts the Iris.</p> <div data-bbox="547 379 771 472" style="text-align: center;"> </div> <p>Off: Normal contrast. VPL-AW10 Auto: Automatically switches to an optimum iris according to a projected scene. The contrast of the scene is emphasized most. On: Emphasizes the contrast and enhances the black. Off: Normal contrast.</p> |
| | <p>Lamp Control Switches the lamp wattage during projection. High: Normal wattage. Low: Enhances the black by reducing the lamp wattage.</p> <p>Tip When you switch from "Low" to "High", the number of turns of the fan increases, and the fan noise becomes slightly louder.</p> |
| <p>Contrast</p> | <p>Adjusts the white area of pictures (white level). The higher the setting, the greater the contrast. The lower the setting, the lower the contrast. You can make adjustments by pressing the CONTRAST+/- on the remote control.</p> |
| <p>Brightness</p> | <p>Adjusts the brightness of the picture. The higher the setting, the brighter the picture. The lower the setting, the darker the picture. You can make adjustments by pressing the BRIGHT+/- on the remote control.</p> |
| <p>Color</p> | <p>Adjusts the intensity of the color density. The higher the setting, the greater the intensity. The lower the setting, the lower the intensity.</p> |
| <p>Hue</p> | <p>Adjusts the color tone. The higher the setting, the more greenish the picture becomes. The lower the setting, the more reddish the picture becomes.</p> |
| <p>Color Temp.</p> | <p>Adjusts the color temperature. High: Gives white colors a blue tint. Middle: Gives a neutral tint between "High" and "Low". Low: Gives white colors a red tint. Custom1, Custom2, Custom3: Enables you to adjust, set, and store your favorite color temperature.</p> |

| | |
|--------------------------------------|--|
| Sharpness | Sharpens the outline of the picture, or reduces the noise. The higher the setting, the sharper the picture. The lower the setting, the softer the picture, thus reducing the noise. |
| NR (Noise Reduction) | Reduces the roughness or noise of the picture. Usually, select "Off". If the picture is rough or noisy, select a setting from among "Low", "Middle" or "High" according to the input signal source. |
| DDE (Dynamic Detail Enhancer) | According to the film source you have selected, make a setting for playback. Film: Normally, select this option. Reproduces the 2-3 Pull-Down film sources with smooth picture movement. When the video signal with a format other than the 2-3 Pull-Down is input, "Progressive" is automatically selected. Progressive: Converts an interlace format video signal to a progressive format. Off: Plays a video signal in an interlace format without converting. |
| Black Level Adj. (Adjust) | Produces a bolder, dynamic picture. Set according to the input signal source. High: Gives higher emphasis to the black color. Low: Gives lower emphasis to the black color. Off: Cancels this feature. |
| Gamma Correction | Adjusts the response characteristics of the tone of the picture. Select a favorite tone from three options. Gamma1: Makes a scene a little brighter. Gamma2: Makes a scene brighter. Gamma3: Makes a scene darker. Off: Gamma Correction is "Off". |

Advanced Picture Menu (VPL-AW15 only)

The Advanced Picture is used for adjusting the picture more.

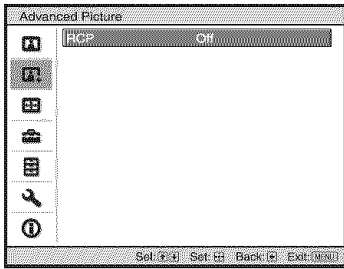

RCP (Real Color Processing) (VPL-AW15 only)

You can adjust the color and hue of each selected portion of the picture independently.

User 1, User 2, User 3: You can adjust the picture using Real Color Processing and store the settings. Once the settings are stored, you can view the picture with the adjusted picture quality.

Off: Cancels this feature.

For details, see "Adjusting the Picture Using Real Color Processing".

(☞ page 33)

Screen Menu

The Screen menu is used to adjust the input signal. You can adjust the size of the picture, and select wide screen mode, etc.

Adjust Screen menu

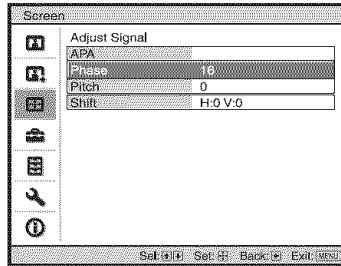
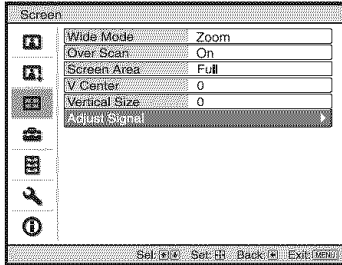

| | |
|---|---|
| <p>Wide Mode (When the input signal is moving picture)</p> | <p>You can set the aspect ratio of the picture to be displayed for the current input signal. This item is enabled only when a moving picture (preset memory numbers 1 to 14) (☞ page 61) is provided.</p> <p>Wide Zoom: A 4:3 aspect ratio picture is enlarged over the entire screen properly. The upper and lower portions of the screen are slightly cut off.</p> <p>Normal: A picture with normal 4:3 aspect ratio is displayed in the center of the screen to fill the vertical screen size.</p> <p>Full: A picture squeezed to 4:3 is displayed with the correct aspect ratio. A 4:3 picture is enlarged horizontally to fit the 16:9 screen.</p> <p>Zoom: A normal 16:9 aspect ratio picture is enlarged vertically and horizontally in the same ratio to fill the screen.</p> |
| <p>Wide Mode (When the PC signal is input)</p> | <p>You can set the aspect ratio of the picture to be displayed for the current input signal. This item is enabled only when an PC signal is input.</p> <p>Full 1: Displays a picture on the whole of the screen without changing the aspect ratio of the original picture.</p> <p>Full 2: Displays a picture on the whole of the screen.</p> <p>Zoom: A normal 16:9 aspect ratio picture is enlarged vertically and horizontally in the same ratio to fill the screen.</p> |
| <p>Over Scan</p> | <p>Hides the outline of the picture.</p> <p>On: Hides the outline of the input picture. Select this setting when noise appears along the edge of the picture.</p> <p>Off: Projects the whole of the input picture.</p> <p>Tip</p> <p>To adjust the display area, refer to “Blanking” on the installation 🗝 menu (☞ page 49). (VPL-AW15 only)</p> |

| | |
|----------------------|---|
| Screen Area | <p>Selects the size of the picture when a Hi-Vision picture is overscanned.</p> <p>Full: Expands the picture on the whole of the screen. Through: Does not expands the picture on the whole of the screen.</p> <p>Note</p> <p>This item is effective only when a Hi-Vision signal (preset memory No. 10 and 11) is input and “On” is selected in “Over Scan”.</p> |
| V Center | <p>Adjust the whole picture by moving up and down on the screen.</p> <p>The entire screen moves up as the selected number increases and moves down as the selected number decreases.</p> <p>Note</p> <p>This item is adjustable only when “Zoom” is selected.</p> |
| Vertical Size | <p>Reduces or enlarges the picture vertically.</p> <p>The screen is enlarged as the setting increases and reduced as the setting decreases. If the subtitle of a movie, etc. cannot be seen, use this together with “V Center”.</p> <p>Note</p> <p>This item is adjustable only when “Zoom” is selected.</p> |
| Adjust Signal | <p>You can adjust the input signal.</p> <p>APA: Adjusts the position of the image signal automatically for “Phase”, “Pitch”, and “Shift”.</p> <p>Phase: Adjusts the dot phase of the panel and the computer signal. Adjust the picture to the point where it looks clearest.</p> <p>Pitch: Adjusts the horizontal size of the picture from a computer. The higher the setting, the wider the picture. The lower the setting, the narrower the picture. Adjust the setting to match the number of dots of the input signal.</p> <p>Shift: Adjusts the position of the picture.</p> <p>H: As the setting for H (horizontal) increases, the picture moves to the right, and as the setting decreases, the picture moves to the left. Use ◀ / ▶ to adjust the horizontal position.</p> <p>V: As the setting for V (vertical) increases, the picture moves up, and as the setting decreases, the picture moves down. Use ↑ / ↓ to adjust the vertical position.</p> |

Setup Menu

The Setup menu is used to change the factory preset settings, etc.

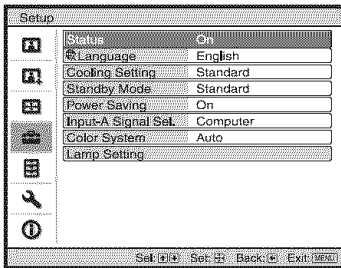

| | |
|------------------------|--|
| Status | <p>Sets whether or not the on-screen display is displayed. Set to "Off" to turn off the on-screen displays except for the menus, message when turning off the power, and warning messages.</p> |
| Language | <p>Selects the language used in the menu and on-screen displays. Available languages are: English, Dutch, French, Italian, German, Spanish, Portuguese, Russian, Swedish, Norwegian, Japanese, Chinese (Simplified Chinese), Chinese (Traditional Chinese), Korean, Thai and Arabic.</p> |
| Cooling Setting | <p>Use this item when using the projector at high altitudes. High: Use this setting when using the projector at an altitude of 1,500 m or higher. Standard: Use this setting when using the projector at normal altitudes.</p> <p>Note When this item is set to "High", the fan noise becomes slightly louder since the number of fan rotation increases.</p> |
| Standby Mode | <p>Lowers the power consumption in standby. When set to "Standard" the power consumption in standby becomes normal. When set to "Low", the power consumption in standby mode is lowered.</p> |
| Power Saving | <p>Sets the power saving mode. When set to "On", the projector goes into power saving mode if no signal is input for 10 minutes. At that time, after the I/O (On/standby) indicator flashes, it will light in orange and the screen becomes dark. In power saving mode, the power saving mode is cancelled if a signal is input or any button is pressed. If you do not want to set the projector to power saving mode, select "Off".</p> |

| | |
|----------------------------|--|
| Input-A Signal Sel. | <p>Selects the type of signal input from the equipment connected to the INPUT A connector.</p> <p>Selects the type of signal input from the equipment by selecting "Input-A" with the INPUT.</p> <p>Auto: Selects the input signal type automatically.</p> <p>Computer: Inputs the signal from a computer.</p> <p>Video GBR: Inputs the signal from a TV game or HDTV broadcast.</p> <p>Component: Inputs the component signal from a DVD player/recorder, Blu-ray Disc player, digital tuner, etc.</p> <p>Note</p> <p>When the input signal is not displayed correctly with this item set to "Auto," select the item according to the input signal.</p> |
| Color System | <p>Selects the color system of the input signal.</p> <p>Auto: Selects the color system of the input signal automatically from among NTSC^{3.58}, PAL, SECAM, NTSC^{4.43}, PAL-M, PAL-N, or PAL60.</p> <p>"NTSC3.58"–"PAL-N": Allows you to set the color system to the selected system manually.</p> <p>Note</p> <p>Normally, set this to "Auto." If the picture is distorted or colorless, select the appropriate color system for the input signal.</p> |
| Lamp Setting | <p>When replacing the lamps, set the desired lamp setting. (☞ page 57)</p> |

Function Menu

The Function menu is used for changing the settings of the various functions of the projector.

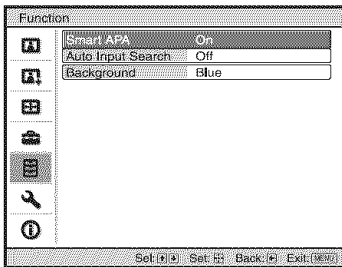





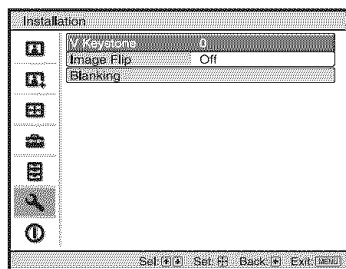

| | |
|--------------------------|--|
| Smart APA | <p>With this item set to On, the APA function works automatically for a signal input from a computer so that the picture can be seen clearly. You can also activate the APA function by pressing the APA on the remote control.</p> <p>Tip The APA (Auto Pixel Alignment) automatically adjusts the input signal from a computer so that the picture can be seen clearly.</p> |
| Auto Input Search | <p>Detects the input signal and displays the detected input signal automatically when the INPUT is pressed.</p> <p>When set to "On", by pressing the INPUT, the projector detects the presence of an input signal in the order of Component, HDMI, Video, S-video, or Input-A signal and displays the input connector of the present input signal.</p> <p>Set this to "Off" when selecting an input connector without an input signal or when selecting the input connector manually.</p> |
| Background | <p>Selects the background color of the screen when no signal is input.</p> <p>You can select "Black" or "Blue".</p> |

Installation Menu

The Installation menu is used for changing the installation settings.



| | | | | | | | | | |
|---------------------------------|--|-------|---|--------|---|------|---|---------|---|
| V Keystone | <p>Corrects the vertical trapezoidal distortion of the picture. When the bottom of the trapezoid is longer than the top (): Sets a lower value (– direction) When the top of the trapezoid is longer than the bottom (): Sets a higher value (+ direction).</p> <p>Note</p> <p>Depending on the picture position adjusted with the lens shift feature, the aspect ratio of the picture may change from the original or picture distortion may occur with V Keystone adjustment.</p> | | | | | | | | |
| Image Flip | <p>Flips the picture on the screen horizontally and/or vertically. HV: Flips the picture horizontally and vertically. H: Flips the picture horizontally. V: Flips the picture vertically. Off: The picture does not flip. Use this item for installation for the backside projection or ceiling installation.</p> | | | | | | | | |
| Blanking (VPL-AW15 only) | <p>This feature allows you to adjust the display area. Select each screen edge “left / right / up / bottom” on the Blanking adjustment screen with  / . Adjust the desired Blanking value with  / .</p> <div data-bbox="557 1086 829 1241" style="border: 1px solid black; padding: 5px; margin: 10px auto; width: fit-content;"> <p>Blanking</p> <table style="width: 100%; border-collapse: collapse;"> <tr><td>Left:</td><td style="text-align: right;">2</td></tr> <tr><td>Right:</td><td style="text-align: right;">3</td></tr> <tr><td>Top:</td><td style="text-align: right;">2</td></tr> <tr><td>Bottom:</td><td style="text-align: right;">3</td></tr> </table> <p style="text-align: right; font-size: small;">Set: [B] Adjust: [C] Set: [B]</p> </div> <p>Note</p> <p>When both the Blanking and the V Keystone are adjusted at the same time, the Blanking cannot be adjusted correctly. When using the Blanking, make sure that you set the V Keystone to “0”.</p> | Left: | 2 | Right: | 3 | Top: | 2 | Bottom: | 3 |
| Left: | 2 | | | | | | | | |
| Right: | 3 | | | | | | | | |
| Top: | 2 | | | | | | | | |
| Bottom: | 3 | | | | | | | | |

Information Menu

The Information menu displays the model name, serial number, the horizontal and vertical frequencies of the input signal and the cumulated hours of usage of the lamp.

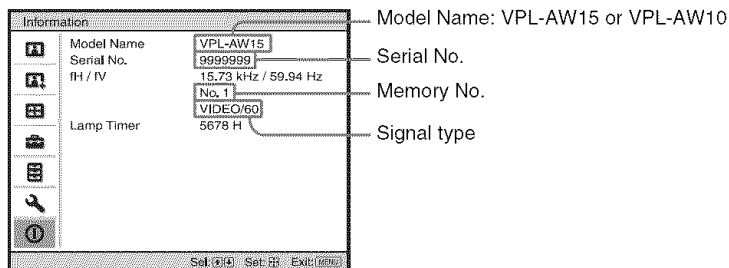



| | |
|----------------------------------|---|
| Model Name | Displays the model name (VPL-AW15 or VPL-AW10) and the serial number. |
| Serial No. | Displays the serial number. |
| fH (horizontal frequency) | Displays the horizontal frequency of the input signal. |
| fV (vertical frequency) | Displays the vertical frequency of the input signal. |
| Memory No. | Displays the preset memory number of the input signal. |
| Signal type | Displays the type of the input signal. |
| Lamp Timer | Indicates how long the lamp has been turned on (total usage). |

Notes

- fH (horizontal frequency) and fV (vertical frequency) may not be displayed depending on the input signal used on the projector.
- You cannot change any items listed above.

About the Preset Memory No.

This projector has 39 types of preset data for input signals (the preset memory). When the preset signal is input, the projector automatically detects the signal type and recalls the data for the signal from the preset memory to adjust it to an optimum picture. The memory number and signal type of that signal are displayed in the Information  menu. You can also adjust the preset data through the Screen  menu.

This projector also contains 20 different user memories beside the preset memories used for inputting computer signals. You can save input signals that have not been preset on these user memories.

When an unpreset signal is input for the first time, a memory number is displayed as 0. When you adjust the data of the signal in the Screen  menu, it will be registered to the projector. If more than 20 user memories are registered, the oldest memory is always overwritten.

See the chart on page 61 to find if the signal is registered to the preset memory.

Note

When the aspect ratio of input signal does not match the screen size, a part of the screen is displayed in black.

This section describes how to solve the problems, how to replace the lamp and air filter, etc.





Troubleshooting



If the projector appears to be operating erratically, try to diagnose and correct the problem using the following instructions. If the problem persists, consult with qualified Sony personnel.

Power

| Symptom | Cause and Remedy |
|-----------------------------|---|
| The power is not turned on. | <ul style="list-style-type: none"> → After about 1 minute, turn the power on. → Close the lamp cover securely, then tighten the screws securely. (☞ page 56) → Close the air filter cover securely. (☞ page 57) → Check warning indicators. (☞ page 53) |

Picture

| Symptom | Cause and Remedy |
|---|--|
| No picture. | <ul style="list-style-type: none"> → Check that the proper connections have been made. (☞ page 17) → Select the input source correctly using the INPUT. (☞ page 27) → Set the computer signal to output from an external monitor. → Set the computer signal to output only to an external monitor. → Select "Computer," "Component" or "Video GBR" for "Input-A Signal Sel." on the Setup  menu according to the input signal. (☞ page 47) |
| The picture from the INPUT A connector is colored strange. | <ul style="list-style-type: none"> → Select "Computer," "Component" or "Video GBR" for "Input-A Signal Sel." on the Setup  menu according to the input signal. (☞ page 47) |
| The picture from the VIDEO INPUT or S VIDEO INPUT connector is colored strange. | <ul style="list-style-type: none"> → Adjust the picture of the Picture  menu. (☞ page 40) → Set "Color System" in the Setup  menu to match the color system being input. (☞ page 47) |
| The color gradation of the dark area or the bright area becomes unclear when an HDMI signal is input. | <ul style="list-style-type: none"> → The color gradation of the dark area or the bright area may become unclear when a signal other than those from HDMI standard cable is input. Adjust the Brightness and the Contrast in the Picture  menu. (☞ page 41) |

| Symptom | Cause and Remedy |
|---------------------------|--|
| The picture is too dark. | → Adjust the contrast or brightness of the Picture  menu properly. (☞ page 41) |
| The picture is not clear. | → Adjust the focus using the focus ring. (☞ page 24) → Condensation has accumulated on the lens. Leave the projector for about 2 hours with the power on. |
| The picture flickers. | → Activate “APA”, then adjust the current input signal. → Adjust “Phase” for “Adjust Signal” in the Screen  menu properly. (☞ page 45) |

On-screen display

| Symptom | Cause and Remedy |
|--|---|
| On-screen display does not appear. | → Set “Status” in the Setup  menu to “On.” (☞ page 46) → Check if the I/O (On/standby) indicator should light in green. |
| The model name does not disappear from the screen. | → The display mode of the projector may be set at the time of purchase. Consult with your local dealer or qualified Sony personnel. |

Remote control

| Symptom | Cause and Remedy |
|-----------------------------------|--|
| The remote control does not work. | → Batteries could be weak. Replace them with new batteries. (☞ page 11) → Insert the batteries with the correct polarities. (☞ page 11) → If there is a fluorescent lamp near the remote control detector, the projector may work improperly or inadvertently. |

Others

| Symptom | Cause and Remedy |
|-------------------|---|
| The fan is noisy. | → Check the setting of “Cooling Setting” in the Setup  menu. (☞ page 46) → Make sure that the room temperature is not too high. The number of fan rotation increases to maintain the product reliability of the projector’s components in a room, where the temperature is higher than normal. The fan noise becomes slightly louder. The approximate normal temperature is 25°C. |

Warning Indicators

The I/⏻ (On/standby) or LAMP/COVER indicator lights up or flashes if there is any trouble with your projector.

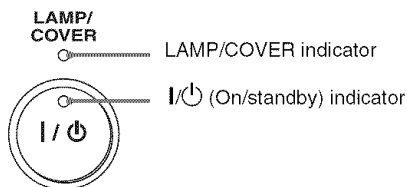

| Symptom | Cause and Remedy |
|---|---|
| LAMP/COVER flashes in red. (A repetition rate of 2 flashes) | <ul style="list-style-type: none"> → Close the lamp cover securely, then tighten the screws securely. (☞ page 56) → Close the air filter cover securely. (☞ page 57) |
| LAMP/COVER flashes in red. (A repetition rate of 3 flashes) | <ul style="list-style-type: none"> → The lamp has reached the end of its useful lifespan. Replace the lamp. (☞ page 55) → The lamp has reached a high temperature. Wait until the lamp cools, and then turn on the power again. |
| I/⏻ (On/standby) flashes in red. (A repetition rate of 4 flashes) | <ul style="list-style-type: none"> → The fan is broken. Consult with qualified Sony personnel. |
| I/⏻ (On/standby) flashes in red. (A repetition rate of 2 flashes) | <ul style="list-style-type: none"> → The internal temperature is unusually high. Check to ensure that if nothing is blocking the ventilation holes or whether or not the projector is being used at high altitudes. |
| I/⏻ (On/standby) flashes in red. (A repetition rate of 6 flashes) | <ul style="list-style-type: none"> → Disconnect the AC power cord, then confirm the I/⏻ (On/standby) lamp is turned off. Turn on the power again after re-connecting it. If the indicators still light up, the electrical system has a problem. Consult with qualified Sony personnel. |

Note

When a warning indicator other than the above status, consult with Sony Customer Information Service Center.

Message Lists

Warning messages

| Message | Cause and Remedy |
|--|--|
| High temp.! Lamp off in 1 min. | <ul style="list-style-type: none"> → Turn off the power. → Check to ensure that nothing is blocking the ventilation holes. (☞ page 13) |
| Frequency is out of range! | <ul style="list-style-type: none"> → Frequency is out of range. Input a signal that is within the acceptable frequency range of the projector. |
| Please check Input-A Signal Sel. | <ul style="list-style-type: none"> → Set “Input-A Signal Sel.” in the Setup  menu to “Computer” when an RGB signal is input from a computer. (☞ page 47) |
| Please replace the Lamp/ Filter. | <ul style="list-style-type: none"> → It is time to replace the lamp. Replace the lamp. (☞ page 55) → Also, replace the air filter too. Restart cleaning the Ventilation holes (intake). (☞ page 55) <p>If this message appears again after you replace the lamp and filter, the lamp replacement process is not complete. Check the lamp replacement process. (☞ page 55)</p> <p>Note</p> <p>To clear this message, press any button either on the remote control or the control panel of the projector once.</p> |
| Please replace the filter. | <ul style="list-style-type: none"> → It is time to replace the air filter. Replace the air filter. (☞ page 58) |
| Please replace the filter. Have you finished? Yes No | <ul style="list-style-type: none"> → It is time to replace the air filter. Replace the air filter. (☞ page 58) → If you replaced the air filter, select “Yes.” If you did not replace the air filter, select “No.” |
| Projector temperature is high. Cooling Setting should be “High” if projector is being used at high altitude. | <ul style="list-style-type: none"> → Check to ensure that the Ventilation holes on the unit are not covered. (☞ page 13) → When using the projector at high altitude, set the Cooling Setting to “High”. (☞ page 46) <p>Note</p> <p>When temperature inside the projector remains high, the Cooling Setting is switched to “High” in 1 minute, then the fan speed increases.</p> |

Caution messages

| Message | Cause and Remedy |
|---|---|
|  | <ul style="list-style-type: none"> → No signal is input in the selected input. Check connections. (☞ page 17) |
| Not applicable! | <ul style="list-style-type: none"> → Press the appropriate button. → The operation to be activated by the button is currently prohibited. |

Replacing the Lamp and the Air Filter and cleaning the Ventilation holes (intake)

Tools you need to get started: Standard Phillips screwdriver Cloth (for scratch protection)

The lamp used for the light source has a certain lifespan. When the lamp dims, the color balance of the picture becomes strange, or “Please replace the Lamp/Filter.” appears on the screen, the lamp may be exhausted. Replace the lamp with a new one (not supplied) without delay.

Use an LMP-H160 Projector Lamp as the replacement lamp.

The air filter is supplied with the LMP-H160 Projector Lamp. When you replace the lamp, it is also time to replace the air filter.

Whenever you replace the lamp, be sure to replace the air filter with a new one. Also clean the ventilation holes (intake).

Caution

- The lamp remains hot after the projector is turned off with the I/⏻ (On/standby) switch. If you touch the lamp, you may burn your fingers. When you replace the lamp, wait for at least an hour for the lamp to cool.
- Do not touch the surface of the lens. If you touch it, wipe off the fingerprints with a soft cloth.
- Pay special attention to replacing the lamp when the projector is installed on the ceiling.
- When removing the lamp unit, make sure it remains horizontal, then pull straight up. Do not tilt the lamp unit. If you pull out the lamp unit while tilted and if the lamp breaks, the pieces may scatter, causing injury.
- When you remove the air filter, be careful not to let any dust fall into the projector.
- Replacing the air filter is crucial to maintain the good performance of the projector or to prevent malfunction to it. When a warning message for replacing the air filter appears, replace the air filter immediately.

- 1 Turn off the projector and unplug the AC power cord.
- 2 When setting the projector on a flat surface such as a desk etc., put a cloth to prevent the surface from being scratched. Reverse the projector as illustrated, then place it on the cloth.

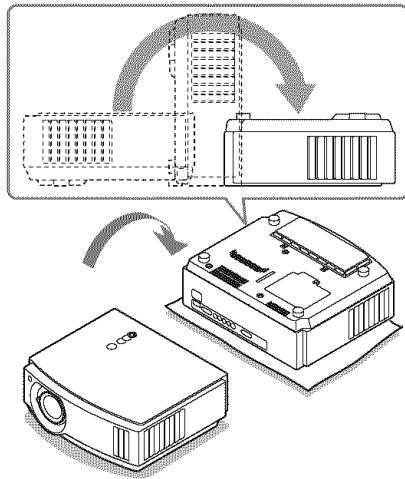

Notes

- When the lamp is damaged the broken pieces of the lamp may become scattered, if you do not reverse the projector. This may cause injury.
- Be sure that the projector is placed on a stable surface.

- 3 Loosen the screw on the lamp cover with a Phillips screwdriver, and then open the lamp cover.

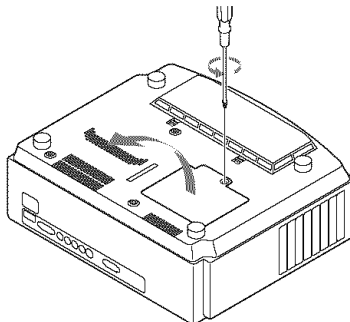

- 4** Loosen the three screws on the lamp with the Phillips screwdriver. Hold up the handle, then pull the lamp straight out.

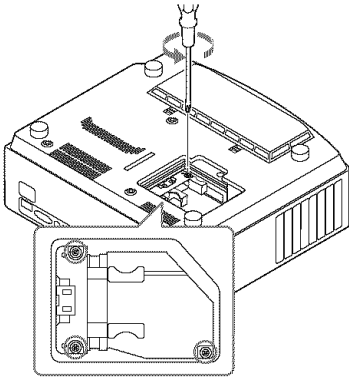

- 5** Hold the handle of the new lamp and push it in securely until it reaches the end, and then tighten the 3 screws.

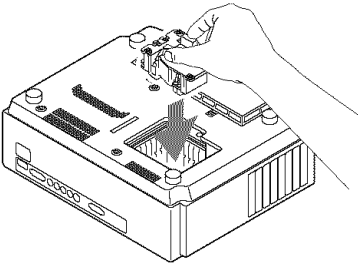

Notes

- Be careful not to touch the optical block inside the unit.
- If the 3 screws are not tightened securely, the lamp cover will not close.

- 6** Close the lamp cover, then tighten the screws.

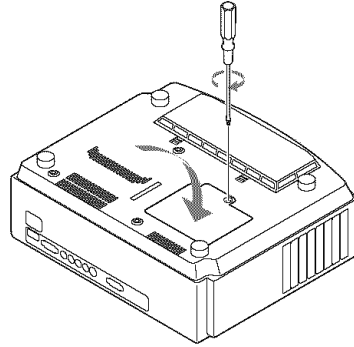

Note

If the lamp cover is not set securely, the power will not turn on.

- 7** Remove the air filter cover.

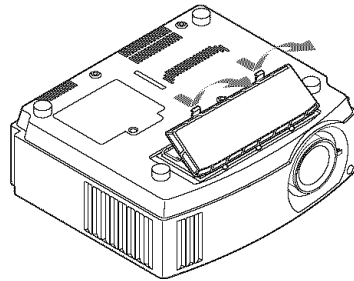

- 8** Remove the air filter.

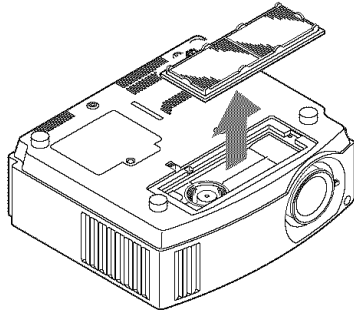

9 Place a new air filter.

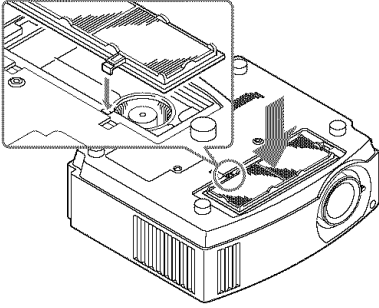

Note

After removing the air filter, do not touch the fan inside the projector.

10 Attach the air filter cover.

11 Wipe dust off the Ventilation holes (intake) with a soft cloth.

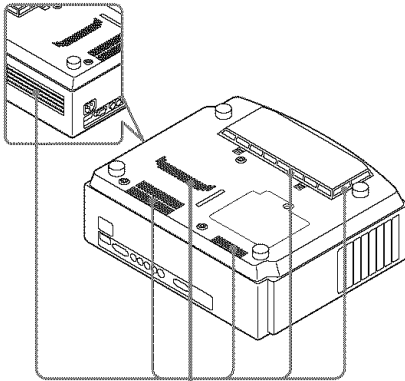

Ventilation holes (intake)

Note

The projector will not turn on unless the air filter cover is securely closed.

12 Place the project back on its original position.

13 Turn on the projector, then select the desired setting item on the Setup menu. The menu screen below will be appeared.

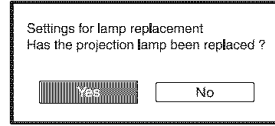

14 Select "Yes".

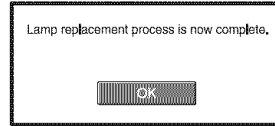

15 Select "OK".

Caution

Do not put your hands into the lamp replacement slot, and do not allow any liquid or other objects into the slot to avoid electrical shock or fire.

Notes

- Be sure to use an LMP-H160 Projector Lamp for replacement. If you use lamps other than the LMP-H160, the projector may malfunction.
- Be sure to turn off the projector and unplug the power cord before replacing the lamp, then check the I/⏻ (On/standby) indicator has already been turned off.
- The projector will not turn on unless the lamp is securely installed in place.
- The projector will not turn on unless the lamp cover are securely closed.
- To cancel a message displayed on the screen, press either the button on the remote control or the one on the control panel on the projector.

Note

The lamp contains mercury. The disposal rules for used fluorescent tubes depend on where you live. Follow the waste disposal policy in your area.

Replacing the Air Filter

When “Please replace the filter.” appears on the screen, you should replace the air filter. The air filter should be replaced every 1,500 hours. This value varies depending on the environment or how the projector is used. 1,500 hours are approximate.

Notes

- For details on how to attach and remove the air filter, see “Replacing the Lamp and the Air Filter and cleaning the Ventilation holes (intake)” Steps 7 to 11. (☞ page 56)
- When you remove the air filter, be careful not to let any dust fall into the projector.
- Replacing the air filter is crucial to maintain the good performance of the projector or to prevent malfunction to it. When a warning message for replacing the air filter appears, replace the air filter immediately.

Fitting the lens cap

When fitting the lens cap onto the lens, position the lens cap so that the concave on the side of the lens cap will fit the zoom lever, as shown in the illustration.

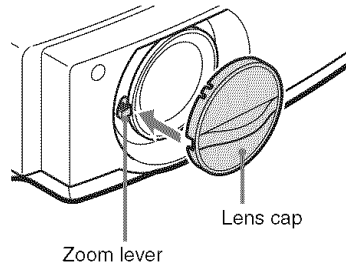

Note

The lens cap will not fit if the position is not set correctly.

Specifications

System

| | |
|-----------------------------|--|
| Projection system | 3LCD panel, 1 lens, 3 primary color LCD shutter projection system |
| LCD panel | 0.73-inch (18.5 mm) TFT LCD panel 2,764,800 pixels (921,600 pixels × 3) |
| Lens | 1.6 times zoom lens (manual) f=21.3 to 34.1 mm/F2.4 to 3.1 |
| Lamp | 165 W Ultra High Pressure Lamp |
| Projection picture size | 40 to 200 inches (measured diagonally) |
| Color system | NTSC _{3.58} /PAL/SECAM/NTSC _{4.43} /PAL-M/PAL-N/PAL60 system, switched automatically/ manually (PAL60 system not switched manually) |
| Acceptable video signals | 15 kHz RGB/component 50/60 Hz, Progressive component 50/60 Hz, DTV (480/60i, 576/50i, 480/60p, 576/50p, 720/60p, 720/50p, 1080/60i, 1080/50i, 1080/48i), 1080/60p (HDMI input only), 1080/50p (HDMI input only), 1080/24p (HDMI input only), Composite video, Y/C video |
| Acceptable computer signals | fH: 19 to 72 kHz fV: 48 to 92 Hz Maximum resolution 1920× 1080, fV: 60 Hz |

Input

| | |
|-------------|--|
| Video input | VIDEO: phono type Composite video: 1 V _{p-p} ±2 dB sync negative (75 ohms terminated) S VIDEO: Y/C mini DIN 4-pin type Y (luminance): 1 V _{p-p} ±2 dB sync negative (75 ohms terminated) C (chrominance): burst 0.286 V _{p-p} ±2 dB (NTSC) (75 ohms terminated), or burst 0.3 V _{p-p} ±2 dB (PAL) (75 ohms terminated) |
|-------------|--|

Y P_B/C_B P_R/C_R

Component: phono type
Y with Sync: 1 V_{p-p}±2dB sync negative (75 ohms terminated)
P_B/C_B: 0.7 V_{p-p}±2dB (75 ohms terminated)
P_R/C_R: 0.7 V_{p-p}±2 dB (75 ohms terminated)

HDMI INPUT A

Digital RGB/Y C_B (P_B) C_R (P_R) HD D-sub 15-pins

Analog RGB/component:
R/C_R (P_R): 0.7 V_{p-p}±2 dB (75 ohms terminated)
G: 0.7 V_{p-p}±2 dB (75 ohms terminated)
G with sync/Y: 1 V_{p-p}±2 dB sync negative (75 ohms terminated)
B/C_B (P_B): 0.7 V_{p-p}±2 dB (75 ohms terminated)
SYNC/HD: Composite sync input: TTL level, positive/negative
Horizontal sync input: TTL level, positive/negative
VD: Vertical sync input: TTL level, positive/negative

REMOTE

RS-232C: D-sub 9-pin (female)

General

| | |
|-----------------------|---|
| Dimensions | 370 × 119 × 320 mm (14 ⁵ / ₈ × 4 ³ / ₄ × 12 ⁵ / ₈ inches) (w/h/d) |
| Mass | VPL-AW15 : Approx. 6.0 kg (13 lb 04 oz) VPL-AW10 : Approx. 5.8 kg (12 lb 13 oz) |
| Power requirements | 100 - 240 V, 2.65 - 1.05 A, 50/60 Hz |
| Power consumption | Max. 265 W Standby mode: 7 W Standby mode (low): 0.5 W |
| Operating temperature | 5°C to 35°C (41°F to 95°F) |
| Operating humidity | 35% to 85% (no condensation) |
| Storage temperature | -20°C to +60°C (-4°F to +140°F) |
| Storage humidity | 10% to 90% |

Supplied accessories

- Remote control
 - RM-PJAW15 (1)
(VPL-AW15 only)
 - RM-PJAW10 (1)
(VPL-AW10 only)
- Size AA (R6) batteries (2)
- AC power cord (1)
- Air filter (for replacement) (1)
- Lens Cap (1)
- Operating Instructions (1)

Design and specifications are subject to change without notice.

Optional accessories

- Projector Lamp LMP-H160 (for replacement)
- Projector Suspension Support PSS-H10, PSS-610

Warning on power connection

Use a proper power cord for your local power supply.

| | The United States, Canada | Continental Europe | UK, Ireland, Australia, New Zealand | Japan |
|----------------------------|------------------------------|--------------------|---|----------|
| Plug type | YP-3 | YP-12A | * | YP-359 |
| Female end | YC-13 | YC-13D | VM0303B | YC-13 |
| Cord type | SVT | H05VV-F | CEE (13) 53 rd (OC) | VCTF |
| Rated Voltage & Current | 10A/125V | 10A/250V | 10A/250V | 12A/125V |
| Safety approval | UL/CSA | VDE | VDE | DENANHO |

* Use a rated plug that complies with the regulation of each country/region and the specifications.

Preset Signals

The following table shows the signals and video formats which you can project using this unit.

When a signal other than the preset signal shown below is input, the picture may not be displayed properly.

| Memory No. | Preset signal (Resolution) | | fH (kHz) | fV (Hz) | Sync | H Size |
|------------|----------------------------|---|----------|---------|--|--------|
| 1 | VIDEO/60 | 60 Hz | 15.734 | 59.940 | – | – |
| 2 | VIDEO/50 | 50 Hz | 15.625 | 50.000 | – | – |
| 3 | 480/60i | DTV 480/60i (720 × 480i) | 15.734 | 59.940 | SonG/Y or composite sync | – |
| 4 | 576/50i | DTV 576/50i (720 × 576i) | 15.625 | 50.000 | SonG/Y or composite sync/composite video | – |
| 5 | 480/60p | 480/60p (720 × 480p) (Progressive NTSC) | 31.470 | 60.000 | SonG/Y | – |
| 6 | 576/50p | 576/50p (720 × 576p) (Progressive PAL) | 31.250 | 50.000 | SonG/Y | – |
| 7 | 1080/60i | 1035/60i (1920 × 1035i), 1080/60i (1920 × 1080i) | 33.750 | 60.000 | SonG/Y | – |
| 8 | 1080/50i | 1080/50i (1920 × 1080i) | 28.130 | 50.000 | SonG/Y | – |

| Memory No. | Preset signal (Resolution) | | fH (kHz) | fV (Hz) | Sync | H Size |
|------------|----------------------------|-------------------------|----------|---------|--------------|--------|
| 9 | 1080/24PsF | 1080/48i (1920 × 1080i) | 27.000 | 48.000 | SonG/Y | — |
| 10 | 720/60p | 720/60p (1280 × 720p) | 45.000 | 60.000 | SonG/Y | — |
| 11 | 720/50p | 720/50p (1280 × 720p) | 37.500 | 50.000 | SonG/Y | — |
| 12 | 1080/60p | 1080/60p (1920 × 1080p) | 67.500 | 60.000 | — | — |
| 13 | 1080/50p | 1080/50p (1920 × 1080p) | 56.260 | 50.000 | — | — |
| 14 | 1080/24p | 1080/24p (1920 × 1080p) | 26.973 | 23.976 | — | — |
| 21 | 640 × 350 | VGA-1 (VGA350) | 31.469 | 70.086 | H-pos, V-neg | 800 |
| 22 | | VESA 85 (VGA350) | 37.861 | 85.080 | H-pos, V-neg | 832 |
| 23 | 640 × 400 | NEC PC98 | 24.823 | 56.416 | H-neg, V-neg | 848 |
| 24 | | VGA-2 (TEXT)/VESA70 | 31.469 | 70.086 | H-neg, V-pos | 800 |
| 25 | | VESA 85 (VGA400) | 37.861 | 85.080 | H-neg, V-pos | 832 |
| 26 | 640 × 480 | VESA 60 | 31.469 | 59.940 | H-neg, V-neg | 800 |
| 27 | | Mac 13 | 35.000 | 66.667 | H-neg, V-neg | 864 |
| 28 | | VESA 72 | 37.861 | 72.809 | H-neg, V-neg | 832 |
| 29 | | VESA 75 (IBM M3) | 37.500 | 75.000 | H-neg, V-neg | 840 |
| 30 | | VESA 85 (IBM M4) | 43.269 | 85.008 | H-neg, V-neg | 832 |
| 31 | 800 × 600 | VESA 56 | 35.156 | 56.250 | H-pos, V-pos | 1024 |
| 32 | | VESA 60 | 37.879 | 60.317 | H-pos, V-pos | 1056 |
| 33 | | VESA 72 | 48.077 | 72.188 | H-pos, V-pos | 1040 |
| 34 | | VESA 75 (IBM M5) | 46.875 | 75.000 | H-pos, V-pos | 1056 |
| 35 | | VESA 85 | 53.674 | 85.061 | H-pos, V-pos | 1048 |
| 36 | 832 × 624 | Mac 16 | 49.724 | 74.550 | H-neg, V-neg | 1152 |
| 37 | 1024 × 768 | VESA 60 | 48.363 | 60.004 | H-neg, V-neg | 1344 |
| 38 | | VESA 70 | 56.476 | 70.069 | H-neg, V-neg | 1328 |
| 39 | | VESA 75 | 60.023 | 75.029 | H-pos, V-pos | 1312 |
| 45 | 1280 × 960 | VESA 60 | 60.000 | 60.000 | H-pos, V-pos | 1800 |
| 47 | 1280 × 1024 | VESA 60 | 63.974 | 60.013 | H-pos, V-pos | 1696 |

| Memory No. | Preset signal (Resolution) | | fH (kHz) | fV (Hz) | Sync | H Size |
|------------|----------------------------|---------------|----------|---------|--------------|--------|
| 50 | 1400 × 1050 | SXGA + | 65.317 | 59.978 | H-neg, V-pos | 1864 |
| 55 | 1280 × 768 | 1280 × 768/60 | 47.776 | 59.870 | H-neg, V-pos | 1664 |
| 56 | 1280 × 720 | 1280 × 720/60 | 44.772 | 59.855 | H-neg, V-pos | 1664 |

Preset memory numbers for each input signal

Analog signal

| Signal | Preset memory number |
|---|----------------------|
| Video signal (VIDEO INPUT and S VIDEO INPUT connectors) | 1, 2 |
| Component signal (INPUT A and Y Pb/Cb Pr/Cr connectors) | 3 to 11 |
| Video GBR signal (INPUT A connector) | 3 to 11 |
| Computer signal (INPUT A connector) | 21 to 39, 55 to 56 |

Digital signal

| Signal | Preset memory number |
|-----------------------------------|--------------------------------|
| Component signal (HDMI connector) | 3 to 8, 10 to 14 |
| Video GBR signal (HDMI connector) | 3 to 8, 10 to 14 |
| Computer signal (HDMI connector) | 26, 32, 36, 37, 45, 47, 50, 55 |

Input Signals and Adjustable/Setting Items

Some of the items in the menus cannot be adjusted depending on the input signal. The following tables indicate them.

The items that cannot be adjusted are not displayed in the menu.

| Item | Input signal | | | |
|------------------|---|---|---|----------|
| | Video or S-Video (Y/C) | Component | Video GBR | Computer |
| Advanced Iris | ● | ● | ● | ● |
| Lamp Control | ● | ● | ● | ● |
| Contrast | ● | ● | ● | ● |
| Brightness | ● | ● | ● | ● |
| Color | ● (except for B & W) | ● | ● | – |
| Hue | ● (NTSC _{3.58} / NTSC _{4.43} only, except for B & W) | ● | ● | – |
| Color Temp. | ● | ● | ● | ● |
| Sharpness | ● | ● | ● | – |
| NR | ● | ● (preset memory numbers 3, 4, 7, 8, 9 only) | ● (preset memory numbers 3, 4, 7, 8, 9 only) | – |
| DDE | ● | ● (preset memory numbers 3, 4, 7, 8, 9 only) | ● (preset memory numbers 3, 4, 7, 8, 9 only) | – |
| Black Level Adj. | ● | ● | ● | – |
| Gamma Correction | ● | ● | ● | ● |
| RCP | ● | ● | ● | ● |

● : Adjustable/can be set

– : Not adjustable/cannot be set

Screen menu

| Item | Input signal | | | |
|----------------|------------------------|--|--|----------|
| | Video or S-Video (Y/C) | Component | Video GBR | Computer |
| Wide Mode | ● | ● | ● | ●*2 |
| Over Scan | — | ● | ● | — |
| Screen Area *1 | — | ● (preset memory numbers 10, 11 only) | ● (preset memory numbers 10, 11 only) | — |
| V Position*3 | ● | ● | ● | ● |
| V Size*3 | ● | ● | ● | — |
| APA | — | — | — | ●*4 |
| Phase | — | — | — | ●*4 |
| Pitch | — | — | — | ●*4 |
| Shift | — | ● | ● | ● |

● : Adjustable/can be set

— : Not adjustable/cannot be set



*1: This item is effective only when “Over Scan” is set to “On” in the Screen  menu. It cannot be set at preset signal 1920 × 1080.

*2: If the input signal is from a computer, the setting cannot be made when the aspect ratio is 16:9 or wider.

*3: The setting can be made only when “Zoom” is selected in “Wide Mode”.

*4: The setting can be made only for analog signal.

Note

When connecting a cable such as an HDMI cable, etc., check the type of the signal in the Information Menu ( page 50) and Digital signal ( page 63), and check items that are adjustable/can be set.

Ceiling Installation

Use the PSS-H10 or PSS-610 Projector Suspension Support when you install the projector on a ceiling. The projection distances for ceiling installation are shown below.

When Using the PSS-H10 Projector Suspension Support

- a: Distance between the screen and the installation hole at the ceiling side of the ceiling mount unit (front side)
- x: Distance between the ceiling and the center of the screen such that the picture will not be truncated or blocked

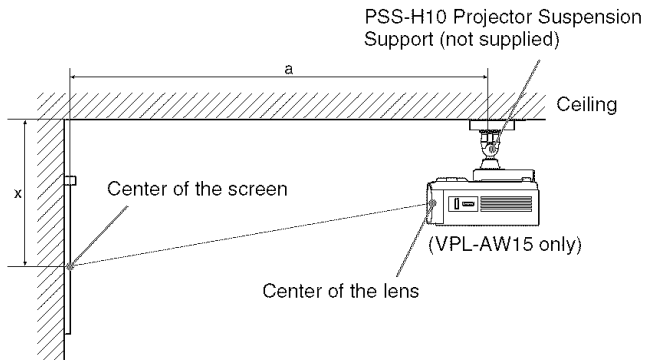

When using the 16:9 aspect ratio screen

Unit: mm (inches)

| Screen Size (inches) | 40 | 60 | 70 | 80 | 100 | 120 | 140 | 160 | 180 | 200 | |
|----------------------|------------------|---|--|--|--|--|--|--|--|--|--|
| (mm) | 1016 | 1524 | 1778 | 2032 | 2540 | 3048 | 3556 | 4064 | 4572 | 5080 | |
| a | Minimum Distance | 1266 (49 ⁷ / ₈) | 1864 (73 ¹ / ₂) | 2163 (85 ¹ / ₄) | 2462 (97) | 3061 (120 ⁵ / ₈) | 3659 (144 ¹ / ₈) | 4257 (167 ⁵ / ₈) | 4855 (191 ¹ / ₄) | 5453 (214 ³ / ₄) | 6051 (238 ³ / ₈) |
| | Maximum Distance | 1999 (78 ³ / ₄) | 2964 (116 ³ / ₄) | 3446 (135 ³ / ₄) | 3929 (154 ³ / ₄) | 4894 (192 ³ / ₄) | 5858 (230 ³ / ₄) | 6823 (268 ³ / ₄) | 7788 (306 ³ / ₄) | 8753 (344 ³ / ₄) | 9717 (382 ⁵ / ₈) |
| x | Minimum Distance | 249 (9 ⁷ / ₈) | 373 (14 ³ / ₄) | 436 (17 ¹ / ₄) | 498 (19 ³ / ₈) | 622 (24 ¹ / ₂) | 747 (29 ¹ / ₂) | 871 (34 ³ / ₈) | 996 (39 ¹ / ₄) | 1120 (44 ¹ / ₈) | 1245 (49) |
| | Maximum Distance | 562 (22 ¹ / ₄) | 724 (28 ¹ / ₂) | 805 (31 ³ / ₄) | 886 (34 ⁷ / ₈) | 1047 (41 ¹ / ₄) | 1209 (47 ⁵ / ₈) | 1371 (54) | 1533 (60 ³ / ₈) | 1695 (66 ³ / ₄) | 1856 (73 ¹ / ₈) |

To calculate the installation measurements (SS: Screen Size)

$$a \text{ (minimum)} = 29.909 (1 \frac{3}{16}) \times SS + 69.614 (2 \frac{3}{4})$$

$$a \text{ (maximum)} = 48.239 (1 \frac{15}{16}) \times SS + 69.631 (2 \frac{3}{4})$$

$$x \text{ (minimum)} = 6.223 (1 \frac{1}{4}) \times SS$$

$$x \text{ (maximum)} = 8.0899 (1 \frac{11}{32}) \times SS + 238.5 (9 \frac{1}{2})$$

When using the 4:3 aspect ratio screen

Unit: mm (inches)

| Screen Size (inches) | 40 | 60 | 70 | 80 | 100 | 120 | 140 | 160 | 180 | 200 | |
|----------------------|------------------|---|--|--|--|--|--|--|--|---|---|
| (mm) | 1016 | 1524 | 1778 | 2032 | 2540 | 3048 | 3556 | 4064 | 4572 | 5080 | |
| a | Minimum Distance | 1534 (60 ¹ / ₂) | 2266 (89 ¹ / ₄) | 2632 (103 ³ / ₄) | 2998 (118 ¹ / ₈) | 3731 (147) | 4463 (175 ³ / ₄) | 5195 (204 ⁵ / ₈) | 5927 (233 ³ / ₈) | 6659 (262 ¹ / ₄) | 7391 (291 ¹ / ₈) |
| | Maximum Distance | 2431 (95 ³ / ₄) | 3612 (142 ¹ / ₄) | 4203 (165 ¹ / ₂) | 4793 (188 ³ / ₄) | 5974 (235 ¹ / ₄) | 7155 (281 ³ / ₄) | 8336 (328 ¹ / ₄) | 9517 (374 ³ / ₄) | 10698 (421 ¹ / ₄) | 11879 (467 ³ / ₄) |
| x | Minimum Distance | 305 (12) | 457 (18) | 533 (21) | 609 (24) | 762 (30) | 914 (36) | 1066 (42) | 1219 (48) | 1371 (54) | 1523 (60) |
| | Maximum Distance | 635 (25) | 833 (32 ⁷ / ₈) | 932 (36 ³ / ₄) | 1031 (40 ⁵ / ₈) | 1229 (48 ³ / ₈) | 1427 (56 ¹ / ₄) | 1625 (64) | 1823 (71 ⁷ / ₈) | 2021 (79 ¹⁹ / ₃₂) | 2219 (87 ³ / ₈) |

To calculate the installation measurements (SS: Screen Size)

$$a \text{ (minimum)} = 36.609 (1 \frac{1}{2}) \times SS + 69.614 (2 \frac{3}{4})$$

$$a \text{ (maximum)} = 59.045 (2 \frac{3}{8}) \times SS + 69.631 (2 \frac{3}{4})$$

$$x \text{ (minimum)} = 7.617 (5 \frac{5}{8}) \times SS$$

$$x \text{ (maximum)} = 9.902 (1 \frac{13}{32}) \times SS + 238.5 (9 \frac{1}{2})$$

Attaching the PSS-H10 projector suspension support

For details on installation on a ceiling, refer to the Installation manual for Dealers of the PSS-H10. Make sure to consult with a qualified Sony personnel for installation.

The installation measurements are shown below when installing the projector on a ceiling using the PSS-H10.

Top view

Install the projector so that the center of the lens is parallel to the center of the screen.

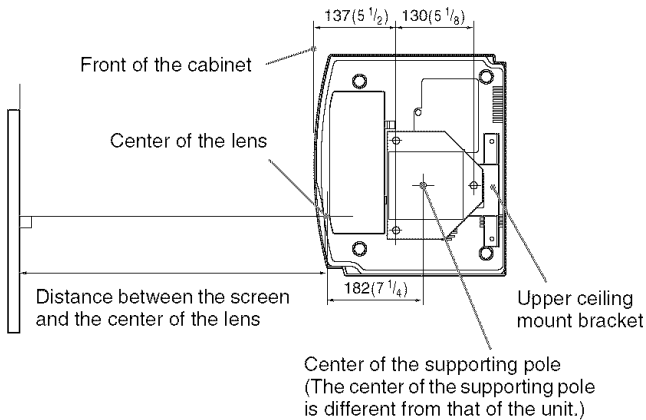

Front view

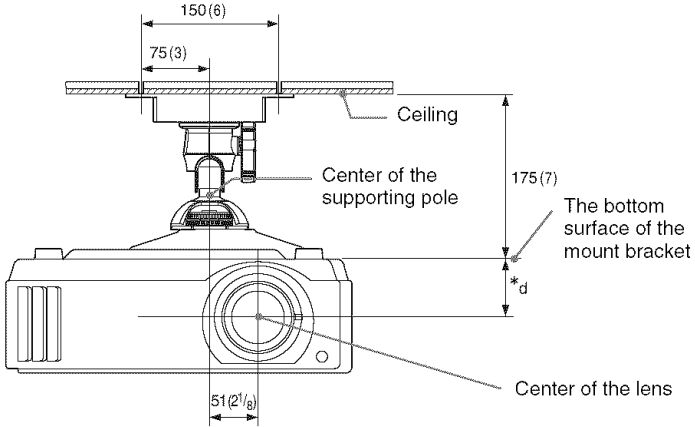

*d

63.5 (2 1/2) (VPL-AW15)

68 (2 3/4) (VPL-AW10)

Side view

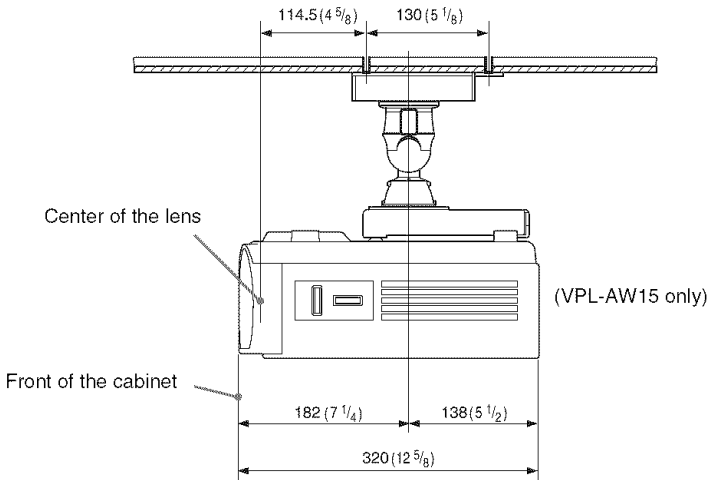

When Using the PSS-610 Projector Suspension Support

- a: Distance between the screen and the installation hole of the upper ceiling mount bracket (front side)
- b: Distance from the ceiling to the bottom surface of the unit
- x: Distance between the ceiling and the center of the screen such that the picture will not be truncated or blocked

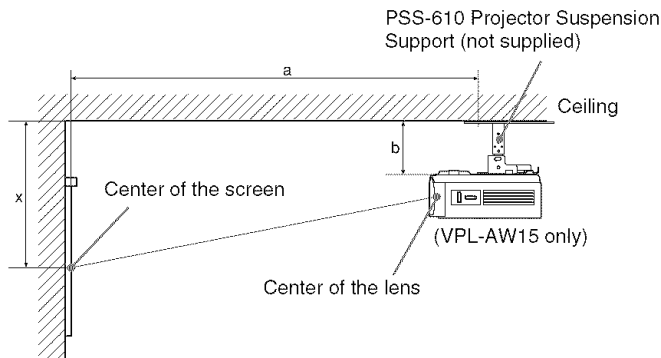

When using the 16:9 aspect ratio screen

Unit: mm (inches)

| Screen Size (inches) | 40 | 60 | 70 | 80 | 100 | 120 | 140 | 160 | 180 | 200 | |
|----------------------|--|--|--|--|--|--|---|---|---|---|---|
| (mm) | 1016 | 1524 | 1778 | 2032 | 2540 | 3048 | 3556 | 4064 | 4572 | 5080 | |
| a | Minimum Distance | 1251 (49 ³ / ₈) | 1850 (72 ⁷ / ₈) | 2149 (84 ⁵ / ₈) | 2448 (96 ¹ / ₂) | 3046 (119 ¹⁵ / ₁₆) | 3644 (143 ¹ / ₂) | 4242 (167 ¹ / ₈) | 4841 (190 ⁵ / ₈) | 5439 (214 ¹ / ₄) | 6037 (237 ³ / ₄) |
| | Maximum Distance | 1987 (78 ¹ / ₄) | 2951 (116 ¹ / ₄) | 3434 (135 ¹ / ₄) | 3916 (154 ¹ / ₄) | 4881 (192 ¹ / ₄) | 5846 (230 ¹ / ₄) | 6811 (268 ¹ / ₄) | 7775 (306 ¹ / ₄) | 8740 (344 ¹ / ₄) | 9705 (382 ¹ / ₄) |
| x | Minimum Distance | 249 (9 ⁷ / ₈) | 373 (14 ³ / ₄) | 436 (17 ¹ / ₄) | 498 (19 ⁵ / ₈) | 622 (24 ¹ / ₂) | 747 (29 ¹ / ₂) | 871 (34 ³ / ₈) | 996 (39 ¹ / ₄) | 1120 (44 ¹ / ₈) | 1245 (49) |
| | Maximum Distance | 387+b (15 ¹ / ₄ +b) | 549+b (21 ⁵ / ₈ +b) | 630+b (24 ⁷ / ₈ +b) | 711+b (28+b) | 872+b (34 ³ / ₈ +b) | 1034+b (40 ³ / ₄ +b) | 1196+b (47 ¹ / ₈ +b) | 1358+b (53 ¹ / ₂ +b) | 1520+b (59 ¹ / ₈ +b) | 1681+b (66 ¹ / ₄ +b) |
| b | 150, 175, 200, 250, 275, 300 mm (6, 7, 7 ⁷ / ₈ , 9 ⁷ / ₈ , 10 ⁷ / ₈ , 11 ⁷ / ₈ inches) adjustable when using PSS-610 | | | | | | | | | | |

To calculate the installation measurements (SS: Screen Size)

- a (minimum) = 29.909 (1 ³/₁₆) × SS + 57.114 (2 ¹/₄)
- a (maximum) = 48.239 (1 ¹⁵/₁₆) × SS + 57.131 (2 ¹/₄)
- x (minimum) = 6.223 (1/4) × SS
- x (maximum) = 8.0899 (1 ¹/₃₂) × SS + 63.5 (2 ¹/₂) + b

When using the 4:3 aspect ratio screen

Unit: mm (inches)

| Screen Size (inches) | 40 | 60 | 70 | 80 | 100 | 120 | 140 | 160 | 180 | 200 | |
|----------------------|---|----------------------|-------------------|----------------------|----------------------|-----------------------|-----------------------|-----------------------|-------------------------|-----------------------|-----------------------|
| (mm) | 1016 | 1524 | 1778 | 2032 | 2540 | 3048 | 3556 | 4064 | 4572 | 5080 | |
| a | Minimum Distance | 1521 (60) | 2254 (88 3/4) | 2620 (103 1/4) | 2986 (117 5/8) | 3718 (146 1/2) | 4450 (175 1/4) | 5182 (204 1/8) | 5915 (233) | 6647 (261 3/4) | 7379 (290 5/8) |
| | Maximum Distance | 2419 (95 1/4) | 3600 (141 3/4) | 4190 (165) | 4781 (188 1/4) | 5962 (234 3/4) | 7143 (281 1/4) | 8323 (327 3/4) | 9504 (374 1/4) | 10685 (420 3/4) | 11866 (467 1/4) |
| x | Minimum Distance | 305 (12) | 457 (18) | 533 (21) | 609 (24) | 762 (30) | 914 (36) | 1066 (42) | 1219 (48) | 1371 (54) | 1523 (60) |
| | Maximum Distance | 460+b (18 1/8 +b) | 658+b (26+b) | 757+b (29 7/8 +b) | 856+b (33 3/4 +b) | 1054+b (41 1/2 +b) | 1252+b (49 3/8 +b) | 1450+b (57 1/8 +b) | 11648+b (458 3/4 +b) | 1846+b (72 3/4 +b) | 2044+b (80 1/2 +b) |
| b | 150, 175, 200, 250, 275, 300 mm (6, 7, 7 7/8, 9 7/8, 10 7/8, 11 7/8 inches) adjustable when using PSS-610 | | | | | | | | | | |

To calculate the installation measurements (SS: Screen Size)

$$a \text{ (minimum)} = 36.609 (1 \frac{1}{2}) \times SS + 57.114 (2 \frac{1}{4})$$

$$a \text{ (maximum)} = 59.045 (2 \frac{3}{8}) \times SS + 57.131 (2 \frac{1}{4})$$

$$x \text{ (minimum)} = 7.617 (5 \frac{1}{16}) \times SS$$

$$x \text{ (maximum)} = 9.902 (1 \frac{3}{32}) \times SS + 63.5 (2 \frac{1}{2}) + b$$

Attaching the PSS-610 projector suspension support

For details on installation on a ceiling, refer to the Installation manual for Dealers of the PSS-610. Make sure to consult with a qualified Sony personnel for installation.

The installation measurements are shown below when installing the projector on a ceiling using the PSS-610.

Top view

Install the projector so that the center of the lens is parallel to the center of the screen.

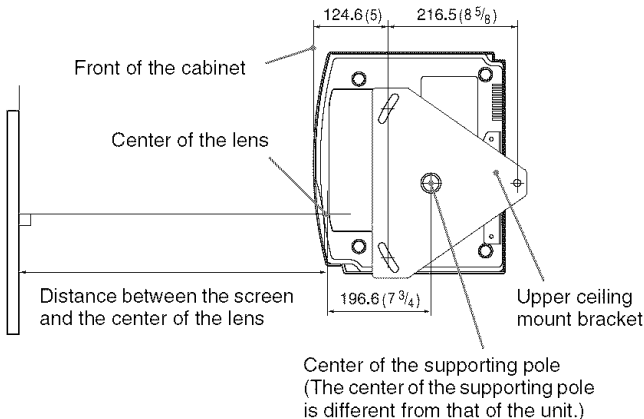

Front view

Distance between the ceiling and the surface of the mount bracket

Using adjustment pipe (b): 150/175/200 mm (6 / 7 / 7 ⁷/₈ inches)

Using adjustment pipe (c): 250/275/300 mm (9 ⁷/₈ / 10 ⁷/₈ / 11 ⁷/₈ inches)

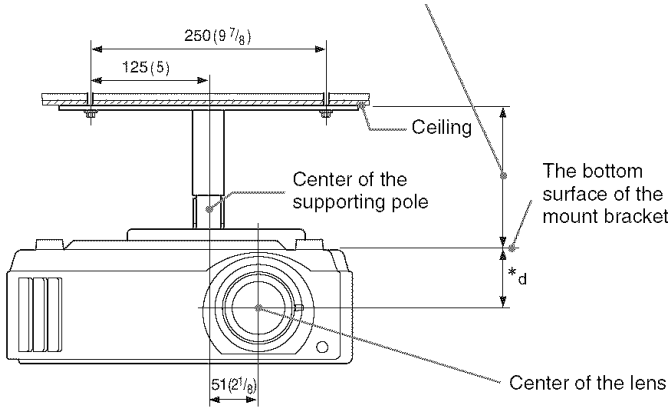

*d

63.5 (2 ¹/₂) (VPL-AW15)

68 (2 ³/₄) (VPL-AW10)

Side view

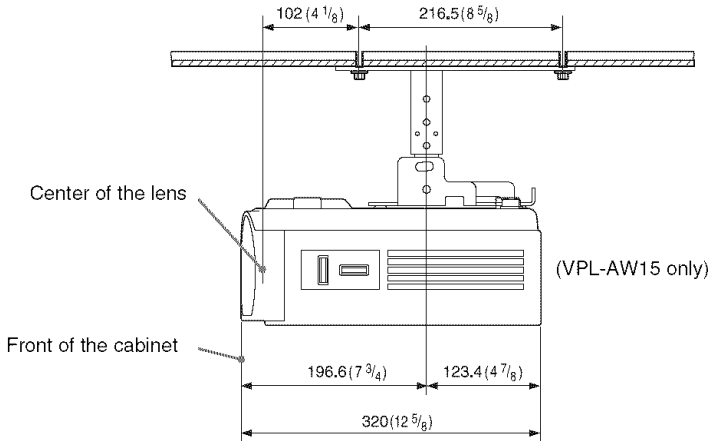

Index

A

| | |
|-------------------------|----|
| Adjust Signal | |
| Phase | 45 |
| Pitch | 45 |
| Shift | 45 |
| Adjuster | 24 |
| Adjusting | |
| picture position | 21 |
| picture quality | 32 |
| Advanced Iris | 41 |
| Auto Input Search | 48 |

B

| | |
|-----------------------|----|
| Background | 48 |
| Black Level Adj. | 42 |
| Blanking | 49 |
| Brightness | 41 |

C

| | |
|----------------------------|----|
| Ceiling Installation | 66 |
| Cinema Black Pro | 41 |
| Color System | 47 |
| Color Temp. | 41 |
| Connecting | |
| Computer | 20 |
| Video equipment | 17 |
| Contrast | 41 |
| Cooling Setting | 46 |

F

| | |
|----------|----|
| fH | 50 |
| fV | 50 |

G

| | |
|------------------------|----|
| Gamma Correction | 42 |
|------------------------|----|

H

| | |
|------------|----|
| HDMI | 18 |
| Hue | 41 |

I

| | |
|--------------------------|----|
| Image Flip | 49 |
| Input-A Signal Sel. | 47 |

L

| | |
|------------------------|----|
| Lamp Timer | 50 |
| Language | 46 |
| Location of Controls | |
| Front/Right side | 8 |
| Rear/Bottom | 9 |

M

| | |
|------------------------|----|
| Menu | |
| Advanced Picture | 43 |
| Function | 48 |
| Information | 50 |
| Installation | 49 |
| Picture | 40 |
| Screen | 44 |
| Setup | 46 |
| Messages | |
| Caution | 54 |
| Warning | 54 |

N

| | |
|----------|----|
| NR | 42 |
|----------|----|

O

| | |
|-----------------|----|
| Over Scan | 44 |
|-----------------|----|

P

| | |
|----------------------|----|
| Picture Mode | |
| CINEMA | 31 |
| Cinema | 40 |
| DYNAMIC | 31 |
| Dynamic | 40 |
| STANDARD | 31 |
| Standard | 40 |
| USER | 31 |
| User | 40 |
| Precautions | 7 |
| Preset Memory | 50 |
| Preset Signals | 61 |

R

| | |
|-------------------------------|----|
| RCP | 43 |
| Remote control | |
| inserting the batteries | 11 |
| location of controls | 10 |
| Reset | |
| resettable items | 39 |
| resetting the items | 39 |

S

| | |
|-----------------------------------|----|
| Screen Area | 45 |
| Selecting the menu language | 25 |
| Sharpness | 41 |
| Specifications | 59 |
| Standby Mode | 46 |
| Status | 46 |
| Supplied accessories | 11 |

T

| | |
|-----------------------|----|
| Troubleshooting | 51 |
|-----------------------|----|

V

| | |
|------------------|----|
| V Keystone | 49 |
|------------------|----|

W

| | |
|-----------------|----|
| WIDE MODE | 28 |
| Wide Mode | |
| Full | 44 |
| Full 1 | 44 |
| Full 2 | 44 |
| Normal | 44 |
| Wide Zoom | 44 |
| Zoom | 44 |



<http://www.sony.net/>



Printed on 70% or more recycled paper.
Standby power consumption 0.5 W
Halogenated flame retardants are not used in cabinets and printed wiring boards.
Uses 50% recycled styrene foam for the packaging cushions.

Sony Corporation Printed in Japan