

Sears

*owners
manual*

**MODEL NO.
113.244400**

SAW ONLY

**MODEL NO.
113.244420**

SAW WITH LEGS

Serial
Number _____

Model and serial
number may be found
at the right-hand side
of the frame.

You should record both
model and serial number
in a safe place for
future use.

CAUTION:

Read **GENERAL** and
ADDITIONAL SAFETY
INSTRUCTIONS
carefully

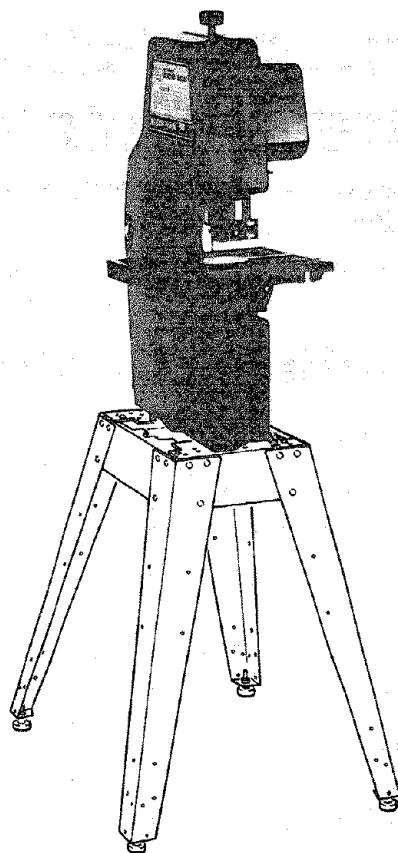

Sears

CRAFTSMAN.

**10-INCH MOTORIZED
BAND SAW**

- *assembly*
- *operating*
- *repair parts*

Sold by **SEARS, ROEBUCK AND CO.**, Chicago, IL. 60684 U.S.A.

FULL ONE YEAR WARRANTY ON CRAFTSMAN BAND SAW

If within one year from the date of purchase, this Craftsman Band Saw fails due to a defect in material or workmanship, Sears will repair it, free of charge.

WARRANTY SERVICE IS AVAILABLE BY SIMPLY CONTACTING THE NEAREST SEARS STORE OR SERVICE CENTER THROUGHOUT THE UNITED STATES.

This warranty gives you specific legal rights, and you may also have other rights which vary from state to state.

SEARS, ROEBUCK AND CO., Sears Tower, BSC 41-3, Chicago, IL 60684

general safety instructions for power tools

- 1. KNOW YOUR POWER TOOL**
Read and understand the owner's manual and labels affixed to the tool. Learn its application and limitations as well as the specific potential hazards peculiar to this tool.
- 2. GROUND ALL TOOLS**
This tool is equipped with an approved 3-conductor cord and a 3-prong grounding type plug to fit the proper grounding type receptacle. The green conductor in the cord is the grounding wire. Never connect the green wire to a live terminal.
- 3. KEEP GUARDS IN PLACE**
— in working order, and in proper adjustment and alignment.
- 4. REMOVE ADJUSTING KEYS AND WRENCHES**
Form habit of checking to see that keys and adjusting wrenches are removed from tool before turning it on.
- 5. KEEP WORK AREA CLEAN**
Cluttered areas and benches invite accidents. Floor must not be slippery due to wax or sawdust.
- 6. AVOID DANGEROUS ENVIRONMENT**
Don't use power tools in damp or wet locations or expose them to rain. Keep work area well lighted. Provide adequate surrounding work space.
- 7. KEEP CHILDREN AWAY**
All visitors should be kept a safe distance from work area.
- 8. MAKE WORKSHOP KID-PROOF**
— with padlocks, master switches, or by removing starter keys.
- 9. DON'T FORCE TOOL**
It will do the job better and safer at the rate for which it was designed.
- 10. USE RIGHT TOOL**
Don't force tool or attachment to do a job it was not designed for.
- 11. WEAR PROPER APPAREL**
Do not wear loose clothing, gloves, neckties or jewelry (rings, wristwatches) to get caught in moving parts. NONSLIP footwear is recommended. Wear protective hair covering to contain long hair. Roll long sleeves above the elbow.
- 12. USE SAFETY GOGGLES (Head Protection)**
Wear safety goggles (must comply with ANSI Z87.1) at all times. "Everyday eyeglasses only have impact resistant lenses, they are NOT safety glasses." Also, use face or dust mask if cutting operation is dusty, and ear protectors (plugs or muffs) during extended periods of operation.
- 13. SECURE WORK**
Use clamps or a vise to hold work when practical. It's safer than using your hand, frees both hands to operate tool.
- 14. DON'T OVERREACH**
Keep proper footing and balance at all times.
- 15. MAINTAIN TOOLS WITH CARE**
Keep tools sharp and clean for best and safest performance. Follow instructions for lubricating and changing accessories.
- 16. DISCONNECT TOOLS**
before servicing; when changing accessories such as blades, bits, cutters, etc.
- 17. AVOID ACCIDENTAL STARTING**
Make sure switch is in "OFF" position before plugging in.
- 18. USE RECOMMENDED ACCESSORIES**
Consult the owner's manual for recommended accessories. Follow the instructions that accompany the accessories. The use of improper accessories may cause hazards.
- 19. NEVER STAND ON TOOL**
Serious injury could occur if the tool is tipped or if the cutting tool is accidentally contacted.
Do not store materials above or near the tool such that it is necessary to stand on the tool to reach them.
- 20. CHECK DAMAGED PARTS**
Before further use of the tool, a guard or other part that is damaged should be carefully checked to ensure that it will operate properly and perform its intended function. Check for alignment of moving parts, binding of moving parts, breakage of parts, mounting, and any other conditions that may affect its operation. A guard or other part that is damaged should be properly repaired or replaced.
- 21. DIRECTION OF FEED**
Feed work into a blade or cutter against the direction of rotation of the blade or cutter only.
- 22. NEVER LEAVE TOOL RUNNING UNATTENDED**
Turn power off. Don't leave tool until it comes to a complete stop.

additional safety instructions for band saw

Safety is a combination of operator common sense and alertness at all times when the band saw is being used.

WARNING: FOR YOUR OWN SAFETY, DO NOT ATTEMPT TO OPERATE YOUR BAND SAW UNTIL IT IS COMPLETELY ASSEMBLED AND INSTALLED ACCORDING TO THE INSTRUCTIONS . . . AND UNTIL YOU READ AND UNDERSTAND THE FOLLOWING:

	PAGE
1. General Safety Instructions for Power Tools . . . 2	
2. Getting To Know Your Band Saw 16	
3. Basic Band Saw Operation 17	
4. Maintenance 18	
5. Stability of Machine.	

Your band saw must be bolted securely to a stand or work bench. In addition, if there is any tendency for the band saw to tip over or move during certain operations such as cutting long heavy boards, bolt your band saw stand or workbench to the floor.

6. Location

This band saw is intended for indoor use only.

7. Protection: Eyes, Hands, Face, Ears, Body

- a. Wear safety goggles that comply with ANSI Z87.1 and a face shield if operation is dusty. Wear ear plugs or muffs during extended periods of operation. Do not wear gloves . . . roll long sleeves above the elbow.
- b. Do not cut pieces of material too small to hold by hand.
- c. Avoid awkward hand positions where a sudden slip could cause a hand to move into the blade.
- d. Never turn your band saw "ON" before clearing the table of all Objects (tools, scraps of wood, etc.) except for the workpiece and related feed or support devices for the operation planned.
- e. Make sure the blade runs downward toward the table. Always adjust tracking wheel correctly so that the blade does not run off the wheels.
- f. Always adjust blade tension correctly.
- g. ALWAYS adjust the upper blade guide and blade guard to just clear the workpiece to protect the operator, to keep blade breakage to a minimum, and to provide maximum support for blade.

h. When cutting a large piece of material, make sure it is supported at table height.

i. Hold the work firmly against the table.

j. Do not feed the material too fast while cutting. Only feed the material fast enough so that the blade will cut. Keep fingers away from the blade.

k. Use caution when cutting off material which is irregular in cross section which could pinch the blade before the cut is completed. A piece of molding for example must lay flat on the table and not be permitted to rock while being cut.

l. Use caution when cutting off round material such as dowel rods, or tubing. They have a tendency to roll while being cut causing the blade to "bite". Always use a "V" block, or clamp round material to a miter guage.

m. When backing up the workpiece, the blade may bind in the kerf (cut) . . . this is usually caused by sawdust clogging up the kerf or because the blade comes out of the guides. If this happens:

1. Turn off the band saw . . . remove plug from power source outlet . . . remove cover from band saw. Insert a screwdriver or wedge in the kerf . . . rotate the wheels by hand while backing up the workpiece.

n. Never leave the band saw work area with the power on, before the machine has come to a complete stop, or without removing and storing the switch key.

o. Never operate band saw with cover removed.

p. Do not perform layout, assembly, or setup work on the table while the cutting tool is rotating.

q. Turn saw "off" and remove plug from power supply outlet before installing or removing an accessory or attachment.

8. Should any part of this band saw be missing, bend, or fail in any way, or any electrical component fail to perform properly, shut off power switch and remove plug from power supply outlet. Replace damaged, missing, and/or failed parts before resuming operation.

9. Think Safety.

Safety is a combination of operator common sense and alertness whenever the band saw is in operation.

10. This band saw is not designed to cut metal.

WARNING: DO NOT ALLOW FAMILIARITY (GAINED FROM FREQUENT USE OF YOUR BAND SAW) TO BECOME COMMONPLACE. ALWAYS REMEMBER THAT A CARELESS FRACTION OF A SECOND IS SUFFICIENT TO INFLICT SEVERE INJURY.

additional safety instructions for band saw



The operation of any power tool can result in foreign objects being thrown into the eyes, which can result in severe eye damage. Always wear safety goggles complying with ANSI Z87.1 (shown on Package) before commencing power tool operation. Safety Goggles are available at Sears retail or catalog stores.

READ AND FOLLOW THE INSTRUCTIONS APPEARING ON THE INSTRUCTION PLATE ON THE FRONT OF THE BAND SAW.

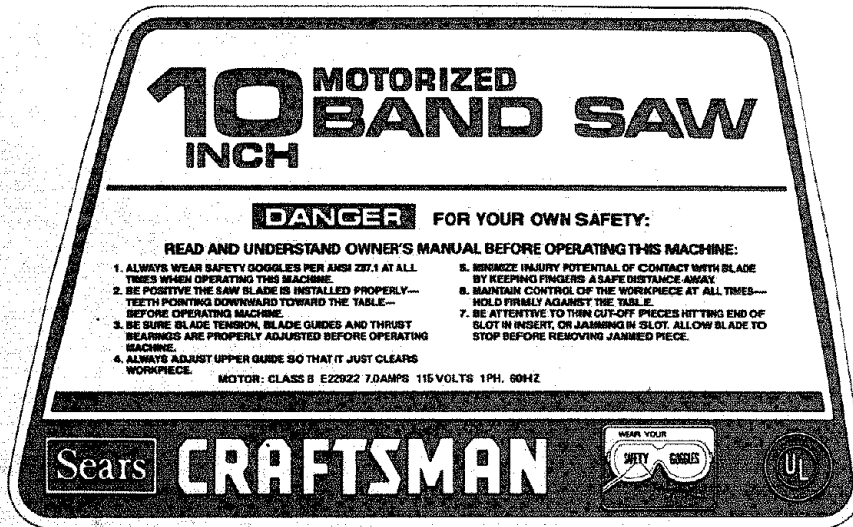

motor specifications and electrical requirements

This machine is designed to use, and is equipped with, a **1725 RPM** motor. It is wired for operation on 110-120 volts, 60 Hz., alternating current. (TOOL MUST NOT BE CONVERTED TO OPERATE ON 230 VOLT).

For replacement motor refer to parts list in this manual.

CONNECTING TO POWER SUPPLY OUTLET

This machine must be grounded while in use to protect the operator from electric shock.

Plug power cord into a 110-120V properly grounded type outlet protected by a 15-amp. time delay or Circuit-Saver fuse or circuit breaker.

If you are not sure that your outlet is properly grounded, have it checked by a qualified electrician.

WARNING: DO NOT PERMIT FINGERS TO TOUCH THE TERMINALS OF PLUGS WHEN INSTALLING OR REMOVING THE PLUG TO OR FROM THE OUTLET.

WARNING: IF NOT PROPERLY GROUNDED THIS POWER TOOL CAN CAUSE AN ELECTRICAL SHOCK PARTICULARLY WHEN USED IN DAMP LOCATIONS CLOSE TO PLUMBING. IF AN ELECTRICAL SHOCK OCCURS THERE IS THE POTENTIAL OF A SECONDARY HAZARD SUCH AS YOUR HANDS CONTACTING THE SAW BLADE.

If power cord is worn or cut, or damaged in any way, have it replaced immediately.

Your unit is for use on 110-120 volts, and has a plug that looks like below.

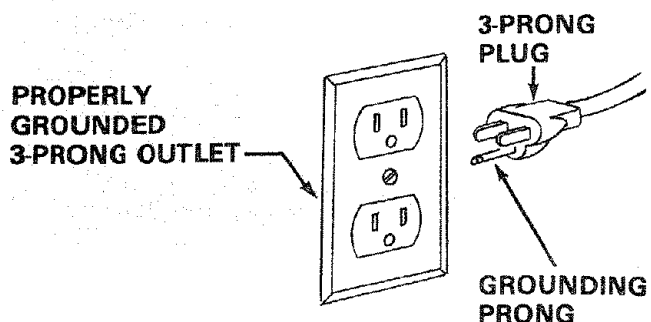

motor specifications and electrical requirements

This power tool is equipped with a 3-conductor cord and grounding type plug which has a grounding prong, approved by Underwriters' Laboratories and the Canadian Standards Association. The ground conductor has a green jacket and is attached to the tool housing at one end and to the ground prong in the attachment plug at the other end.

This plug requires a mating 3-conductor grounded type outlet as shown.

If the outlet you are planning to use for this power tool is of the two prong type **DO NOT REMOVE OR ALTER THE GROUNDING PRONG IN ANY MANNER.** Use an adapter as shown below and always connect the grounding lug to known ground.

It is recommended that you have a qualified electrician replace the TWO prong outlet with a properly grounded THREE prong outlet.

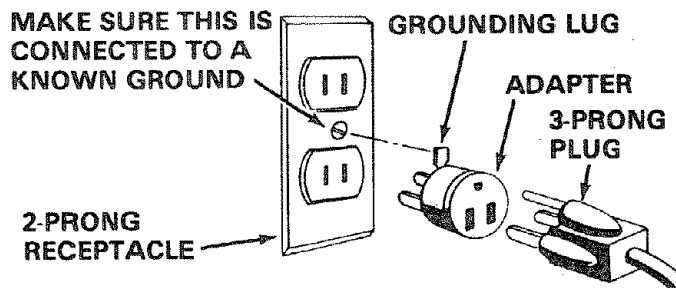

An adapter as illustrated is available for connecting plugs to 2-prong receptacles. The green grounding lug extending from the adapter must be connected to a permanent ground such as to a properly grounded outlet box.

NOTE: The adapter illustrated is for use only if you already have a properly grounded 2-prong receptacle. Adapter is not allowed in Canada by the Canadian Electrical Code.

The use of any extension cord will cause some loss of power. To keep this to a minimum and to prevent overheating and motor burn-out, use the table below to determine the minimum wire size (A.W.G.) extension cord.

Use only 3 wire extension cords which have 3-prong grounding type plugs and 3-pole receptacles which accept the tools plug.

Extension Cord Length	Wire Size A.W.G.
Up to 100 Ft.	16
100 - 200 Ft.	14
200 - 400 Ft.	10

CONTENTS

POWER TOOL WARRANTY.....	2	Adjusting Lower Blade Guide	
GENERAL SAFETY INSTRUCTIONS FOR		Assembly.....	14
POWER TOOLS.....	2	Adjusting Lower Blade Guides.....	15
ADDITIONAL SAFETY INSTRUCTIONS		Adjusting Lower Thrust Roller.....	15
FOR BAND SAW.....	3	Adjusting Table.....	15
MOTOR SPECIFICATIONS AND ELECTRICAL		GETTING TO KNOW YOUR BAND SAW	
REQUIREMENTS.....	4	Tension Adjustment Knob.....	16
UNPACKING AND CHECKING CONTENTS.....	6	Tension Setting.....	16
ASSEMBLY		Guide Bar Lock Screw.....	16
Assembling Steel Legs.....	7	Thrust Roller Adjustment.....	16
Mounting Band Saw on Leg Set.....	8	Table Lock Knob.....	16
Mounting Band Saw to Workbench.....	8	Tilt Scale.....	16
Installing the Table.....	9	Blade Guides.....	16
Installing the Blade.....	9	On-Off Switch.....	16
Tracking the Blade.....	11	BASIC BAND SAW OPERATION	
Adjusting the Table Square to Blade.....	12	Sawing.....	17
Adjusting Guide Bar.....	12	Blade Selection Guide.....	17
Adjusting Front to Back Squareness.....	13	MAINTENANCE.....	18
Adjusting Side to Side Squareness.....	13	Lubrication.....	18
Adjusting Upper Blade Guide		RECOMMENDED ACCESSORIES.....	18
Assembly.....	14	TROUBLESHOOTING.....	19
Adjusting Upper Blade Guides.....	14	REPAIR PARTS.....	20
Adjusting Upper Thrust Roller.....	14		

unpacking and checking contents

TOOLS NEEDED

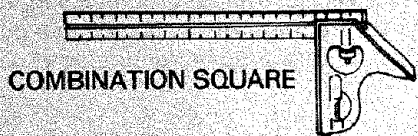

COMBINATION SQUARE



MEDIUM SCREWDRIVER



#2 PHILLIPS SCREWDRIVER



7/16 INCH WRENCH

3/8 INCH WRENCH

1/2 INCH WRENCH



5/32 INCH SET SCREW WRENCH

COMBINATION SQUARE MUST BE TRUE

DRAW LIGHT LINE ON BOARD ALONG THIS EDGE

STRAIGHT EDGE OF BOARD 3/4" THICK THIS EDGE MUST BE PERFECTLY STRAIGHT

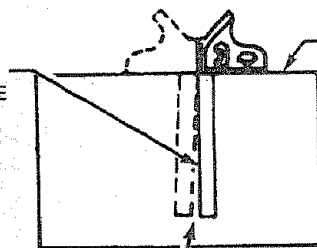

SHOULD BE NO GAP OR OVERLAP HERE WHEN SQUARE IS FLIPPED OVER IN DOTTED POSITION

Model 113.244400 Band Saw is shipped complete in one carton but DOES NOT INCLUDE Steel Legs.

Model 113.244420 Band Saw is shipped complete in one carton and INCLUDES Steel Legs.

Separate all parts from packing materials and check each item with illustration and "Table of Loose Parts". Make certain all items are accounted for, before discarding any packing material.

If any parts are missing, do not attempt to assemble the band saw, plug in the power cord, or turn the switch on until the missing parts are obtained and installed correctly.

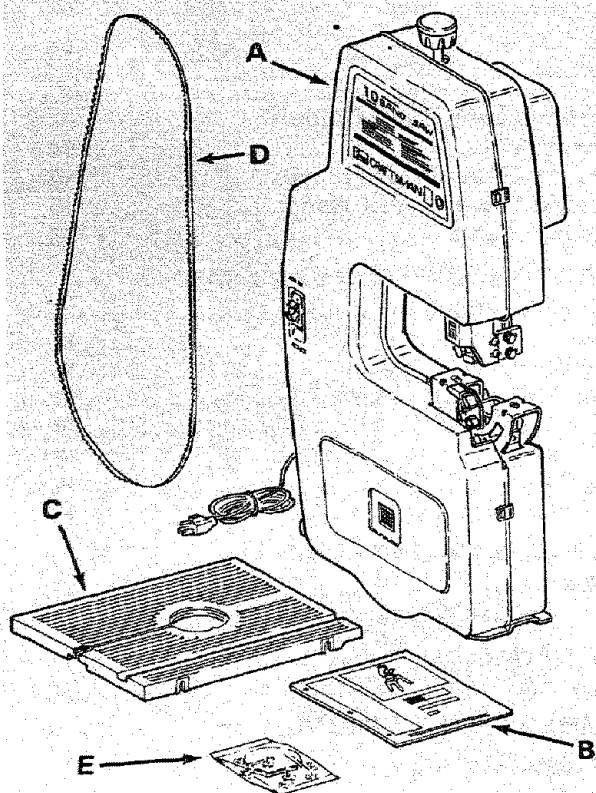

ITEM	TABLE OF LOOSE PARTS	QTY.
A	Basic saw assembly.....	1
B	Owners Manual.....	1
C	Saw Table.....	1
D	Blade, Saw 1/4.....	1
E	Bag Assembly Part - #69132 Containing the following parts:	
	Roller, Blade Thrust.....	2
	Switch, Key.....	1
	Nut, Wing 1/4-20.....	1
	Screw, Truss Hd. 1/4-20 x 1.....	1
	Washer 17/64 x 5/8 x 1/16.....	1
	Insert, Table.....	1
	Screw, Hex Hd. 5/16-18 x 3/4.....	2
	External Lockwasher, 5/16.....	2
	Wrench, Hex "L" 5/32.....	1

unpacking and checking contents

THE FOLLOWING PARTS ARE INCLUDED WITH MODEL 113.244420 ONLY.

Item	Description	Qty.
A	* Nut, Hex Head 1/2-13.....	8
B	* Nut, Hex 1/4-20.....	28
C	* Screw, Truss Hd. 1/4-20 x 5/8.....	28
D	* Lockwasher, 1/4 External.....	28
E	* Foot, Leveling.....	4
F	Leg.....	4
G	Channel, Support.....	2
H	Stiffener, Side.....	2
J	Stiffener, End.....	2
HARDWARE FOR MOUNTING TOOL		
K	* Screw, Hex Hd. 5/16-18 x 1.....	4
L	* Lockwasher Ext. 5/16.....	4
M	* Nut, Hex 5/16-18.....	4
N	* Washer 11/32 ID.....	4

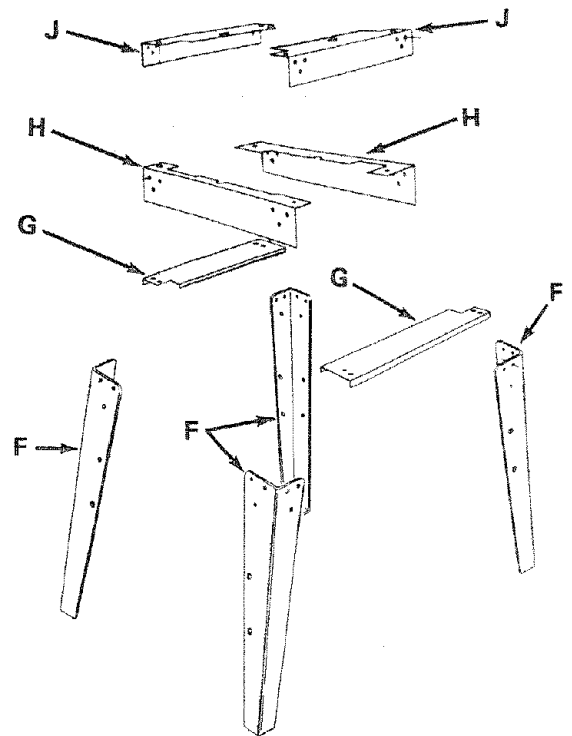

* Parts Contained In Loose Parts Bag Part No. 69097

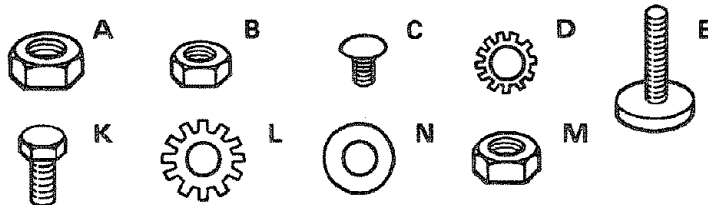

assembly

ASSEMBLING STEEL LEGS

1. Assemble the two (2) End Stiffeners and the two (2) Side Stiffeners using four (4) 1/4-20 Truss head screws. The End Stiffeners are placed on top of each Side Stiffener as shown. Insert screws through the 9/32 inch diameter holes and attach lockwashers and 1/4-20 nuts and finger tighten nuts.
2. Attach the four (4) legs to the Side and End Stiffeners using 1/4-20 screws, lockwashers and nuts as shown.
3. Remove the four (4) Truss head screws which were assembled in Paragraph No. One. Place the two (2) Support Channels as shown, in position, align holes in supports with holes in the Stiffeners, replace lockwashers and nuts. Tighten all nuts using 7/16" wrench.
4. Install leveling feet as shown. To level Leg Set, loosen nut on inside of leg and turn nut on outside to raise or lower feet. Adjust all four levelers, if necessary, and then tighten nuts on inside of leg.

NOTE: These levelers are not intended for height adjustment.

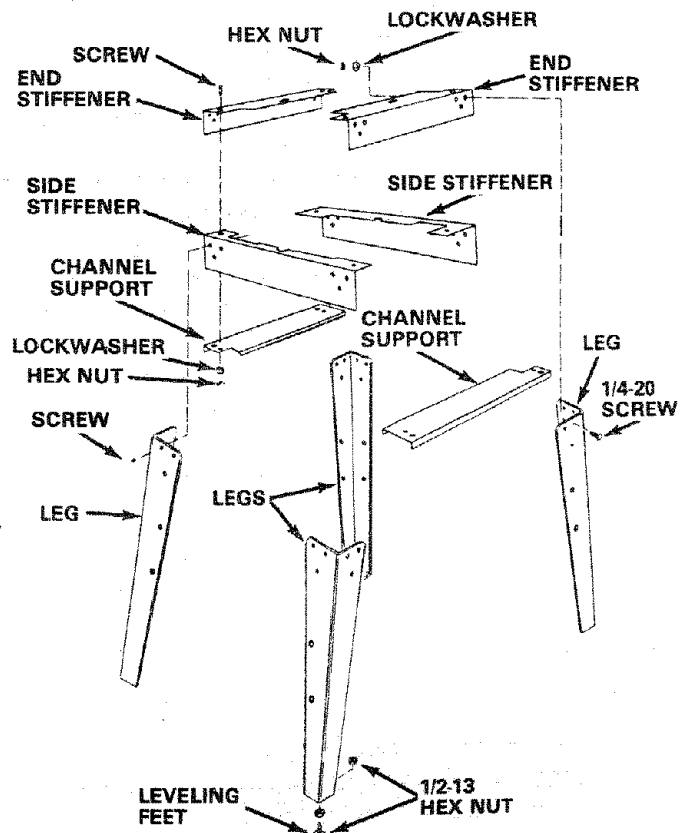

assembly

MOUNTING BAND SAW ON LEG SET

This leg set is included with Model No. 113.244420 only.

NOTE: For illustrative purposes, the Band Saw is shown mounted on the Craftsman Catalog No. 9-22236 Steel Leg Set. If leg set is purchased separately, the motor support is not needed with this band saw.

1. Remove the Band saw cover by releasing 5 latches.

NOTE: Check the bolts which hold the feet to the Band Saw as shown. Make sure they are tight.

CHECK BOLTS FOR TIGHTNESS

LEFT FOOT

RIGHT FOOT

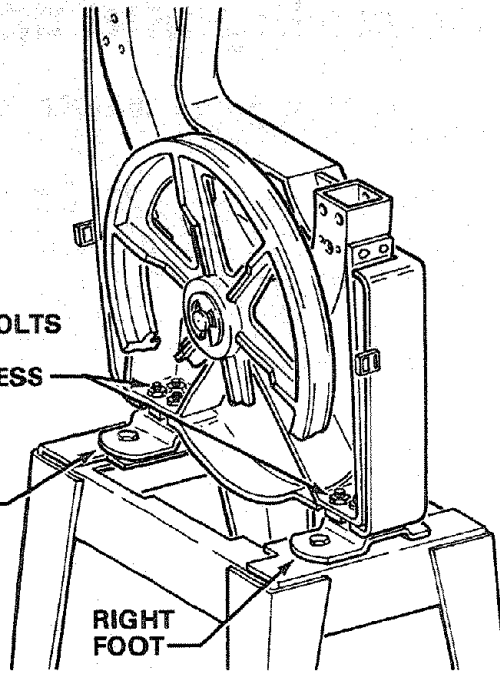

2. Place the Band Saw on the Steel Legs, position as shown, and align the mounting holes in the feet of the Band Saw with those in the END STIFFENERS (marked with an X in the illustration).
3. Mount saw to legs using four 5/16-18x1" hex head screws, lockwashers, and hex nuts. Tighten screws and nuts using 1/2" wrench.

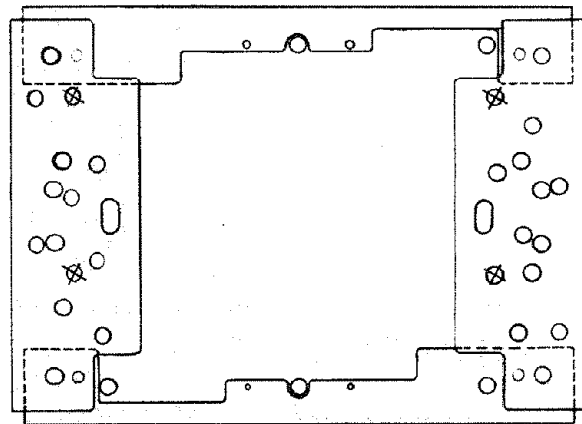

MOUNTING BAND SAW TO WORKBENCH

If band saw is to be used in a permanent location, it should be fastened securely to a firm supporting surface such as a workbench or accessory leg set (9-22236).

If mounting to a workbench, holes should be drilled through supporting surface of the workbench using dimensions illustrated.

1. Each leg should be bolted securely using 5/16" diameter machine screws, lockwashers, and 5/16" hex nuts. Bolts must be of sufficient length to accommodate legs of saw, washers, hex nuts, and thickness of supporting surface.
2. Locate and mark holes where band saw is to be mounted.
3. Drill (4) 11/32" dia. holes through workbench.
4. Remove band saw cover by releasing latches.
5. Place band saw on workbench aligning holes in feet with holes drilled in workbench.
6. Insert and tighten all four screws.

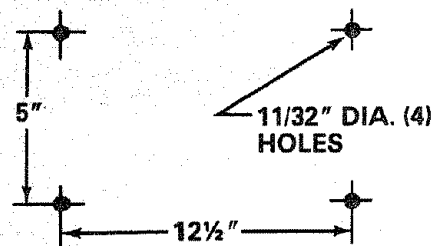

assembly

An alternate method of mounting is to fasten band saw to a mounting board. The board should be of sufficient size to avoid tipping of saw while in use. Any good grade of plywood or chipboard with a 3/4" minimum thickness is recommended.

1. Follow instructions for mounting to workbench, substituting a board 18" x 24" minimum size and using 5/16 inch flat head screws, lockwashers, and hex nuts. Screws must be of sufficient length to accommodate legs of saw, washers, hex nuts, and thickness of supporting board.

NOTE: Holes must be counter sunk so screw heads are flush with surface of supporting board.

2. Securely clamp board to workbench using C clamps.

NOTE: Supporting surface where band saw is mounted should be examined carefully after mounting to insure that no movement during use can result. If any tipping or walking is noted, secure workbench, legs, or supporting surface before operating band saw.

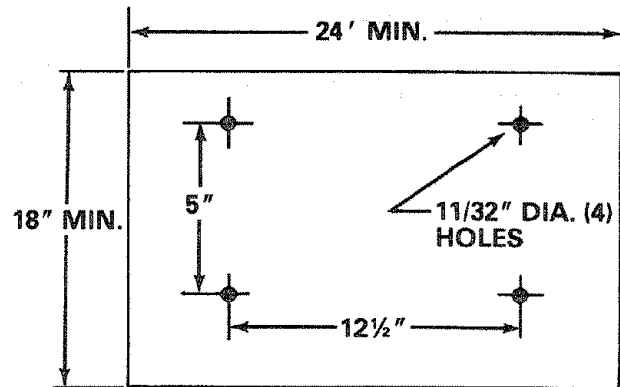

INSTALLING THE TABLE

Apply a coat of automobile wax to the table and inside surfaces of trunnion that slide on frame.

1. Loosen the guide bar lock screw and position the upper guide assembly all of the way up. Tighten lock screw.
2. Locate two (2) 5/16 - 18 x 3/4 inch hex head screws and external lockwashers among loose parts.
3. Position trunnion at the 0 degree position and tighten table lock knob.
4. Place table on trunnion so that the slots in trunnion line up with the mounting holes in table as illustrated.
5. Insert hex head screw and lockwasher through front hole of trunnion into table and tighten.
6. Loosen table Lock Knob and position Trunnion at the 45 degree position.
7. Insert hex head screw and lockwasher through rear hole of trunnion into table and tighten.
8. Return table to the 0 degree position and tighten table lock knob.

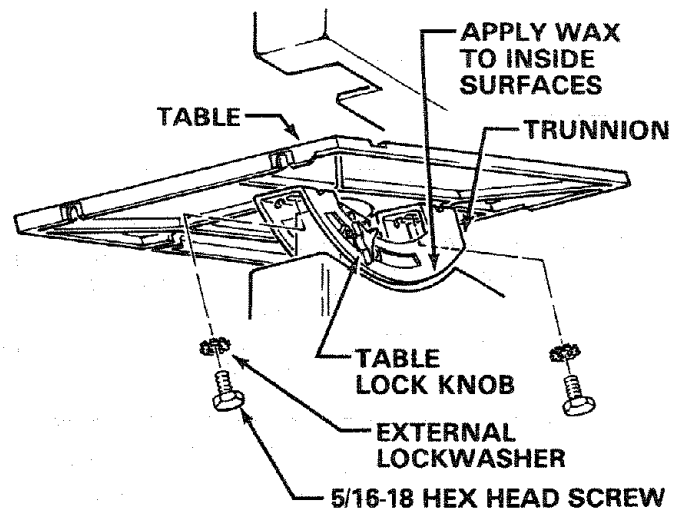

INSTALLING THE BLADE

1. Loosen the two mounting screws and remove the blade guard.
2. Loosen the guide bar lock screw and position the upper guide assembly approximately two inches above the table as shown and tighten the lock screw.

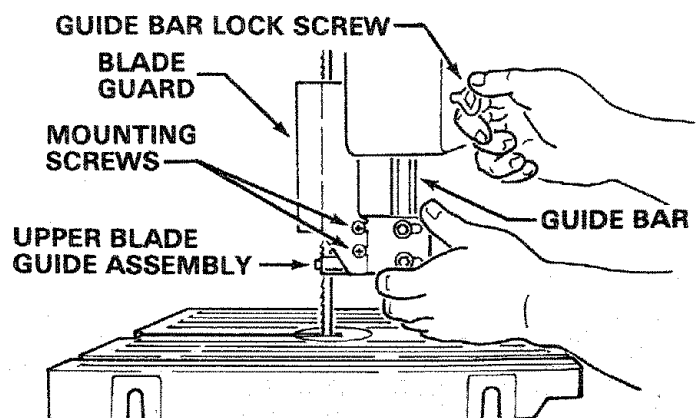

assembly

- Loosen the two cap screws that lock upper blade guides and separate them about 1/8".
- Find a Thrust Roller among loose parts and insert in upper guide assembly.
- Loosen two hex head screws in upper guide assembly and slide assembly all of the way back in the slots.
- Tighten hex head screws.

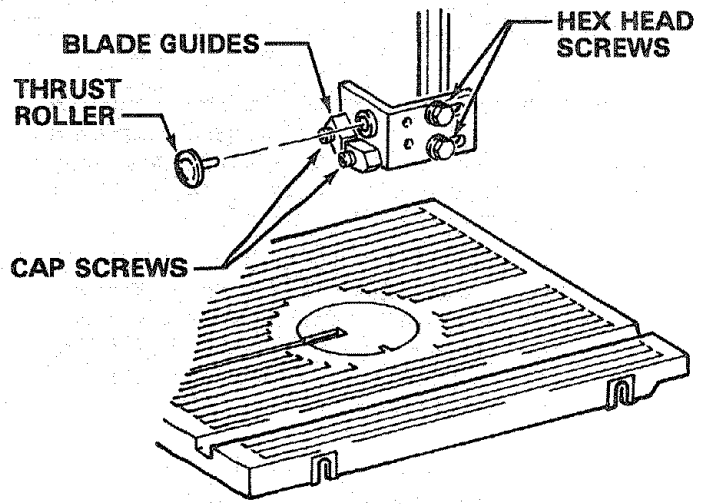

- Loosen lock nut on thrust roller adjustment screw.
- Back out thrust roller adjustment screw by turning counter clockwise using 5/32 inch setscrew wrench.

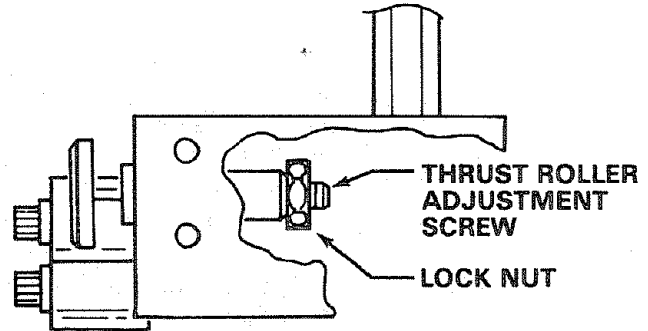

- Loosen the two capscrews that lock the lower blade guides and separate them about 1/8".
- Find a Thrust Roller among loose parts and insert in lower guide assembly.

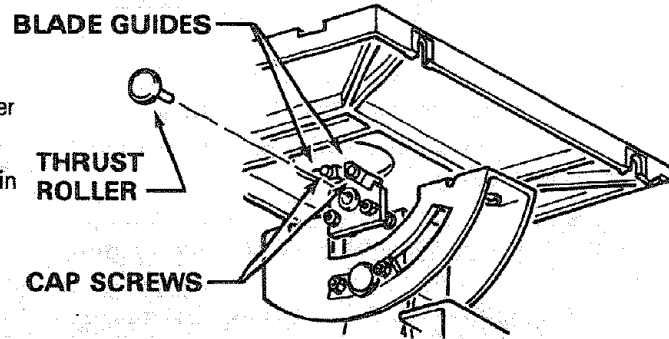

- Loosen lock nut on thrust roller adjustment screw.
- Back out thrust roller adjustment screw by turning counter clockwise using 5/32 inch setscrew wrench.
- Loosen inner and outer lock nuts on lower guide assembly adjustment.
- Turn locknuts clockwise and move lower guide assembly back to the frame tube.

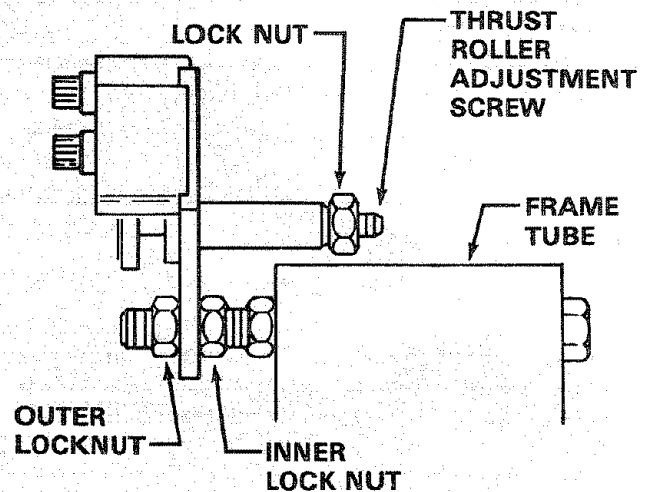

assembly

15. Carefully uncoil the blade holding it at arms length.
16. Place the blade over the wheels with the teeth pointing downward toward the table as shown. Make sure the blade is in the center of the rubber tires.

NOTE: Your band saw can be used with 1/4 or 3/8 inch wide blades, 72 5/8 inches long. A 1/4 inch blade is included with this saw.

17. Turn tension adjustment knob clockwise until the large washer lines up with the tension indicator on the inside of the cover.
18. Turn the upper wheel by hand clockwise a few turns and notice if the blade remains in the approximate center of the tires.

If the blade moves away from the center of the wheels while you are turning it, the blade is not TRACKING properly.

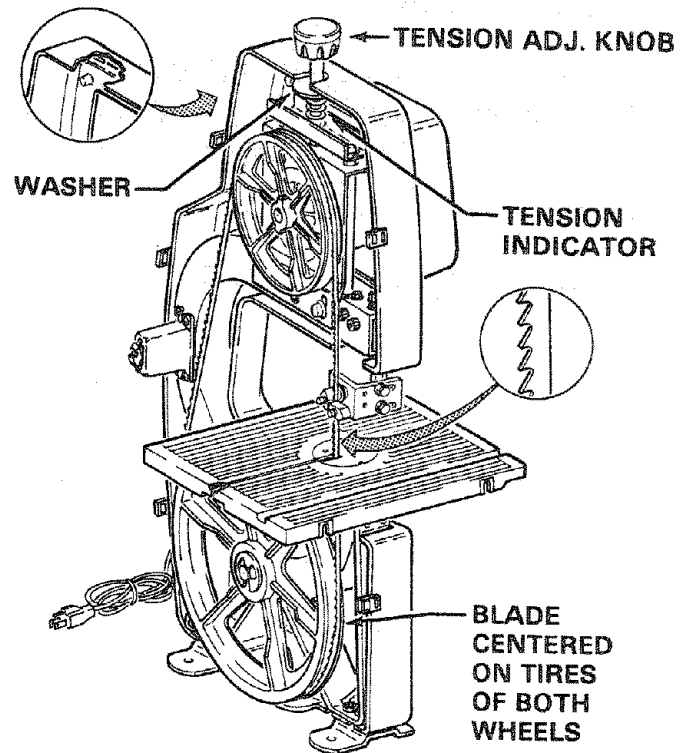

TRACKING THE BLADE

The Motor Bracket is hinged which allows the upper wheel to be tilted so that the blade can be TRACKED. By turning the Tracking Adjustment Screw, the upper wheel will be tilted (see illustration).

If the blade moves toward the front of the band saw:

- a. Turn the tracking adjustment screw clockwise about 1/4 of a turn, as though you were tightening it.

If the blade moves toward the back of the band saw:

- a. Turn the tracking adjustment screw counter clockwise about 1/4 of a turn as though you were loosening it.

Turn the screw just enough to cause the blade to run in the approximate center of both tires.

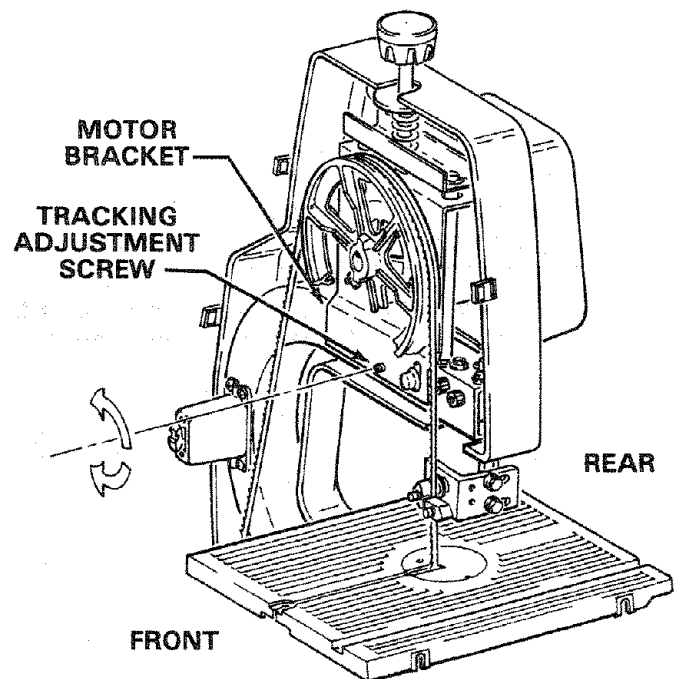

NOTE: IF BLADE CANNOT BE MADE TO RUN IN THE APPROXIMATE CENTER OF THE LOWER WHEEL, IT MAY BE NECESSARY TO REPOSITION THE UPPER WHEEL ON THE MOTOR SHAFT.

1. Loosen the set screw in the upper wheel.
 - a. If the blade is running to the front of lower wheel - Slide upper wheel to the rear toward the motor.
 - b. If the blade is running to the rear of lower wheel - Slide upper wheel to the front away from the motor.
2. Tighten the set screw in the upper wheel.
3. Track the blade by turning the tracking adjustment screw in or out as needed.

assembly

ADJUSTING THE TABLE SQUARE TO BLADE

NOTE: The combination square must be "true". See start of "assembly" section for checking method.

1. Loosen guide bar lock screw and raise the upper blade guide assembly all the way up. Tighten guide bar lock screw.
2. Place a square on the table against the rear edge of the blade as illustrated.
3. If adjustment is required, loosen the two screws in the trunnion stop brackets and tap table up or down until table is square with blade.
4. Tighten screws.

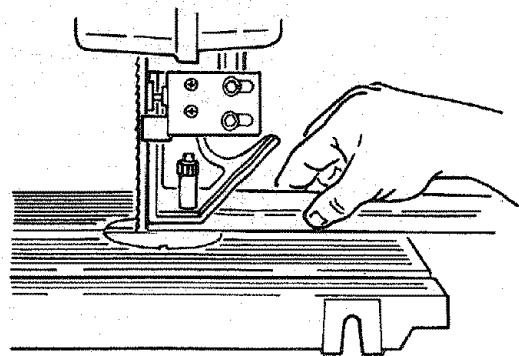

5. Loosen table lock knob.
 6. Place a square on the table against the blade as illustrated.
 7. Tilt table up or down to align table 90 degrees to blade (0 degree position) and tighten table lock knob.
 8. Loosen the two screws in the trunnion stop brackets and slide bracket under lock knob until it rests against end of slot in trunnion.
 9. Tighten screws.
 10. Check squareness of blade to table. Make readjustments if necessary.
 11. Loosen table lock knob.
 12. Tilt table to 45 degree position and check using a combination square.
 13. Loosen the two screws in the trunnion stop brackets and slide bracket on opposite side of lock knob until it rests against end of slot in trunnion.
- NOTE:** Be careful not to change position of slide bracket under lock knob that set the 0 degree position.
14. Tighten screws.
 15. Check blade to table at the 45 degree position.
 16. Loosen table lock knob and position table at 0 degree position; recheck squareness.
 17. Make readjustments if necessary.

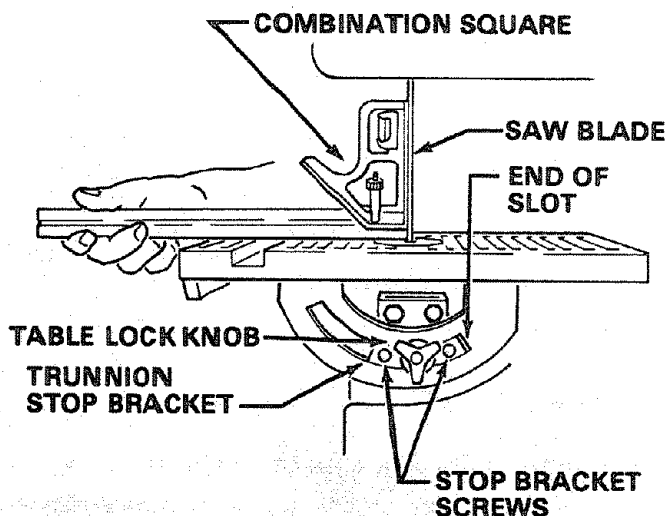

ADJUSTING GUIDE BAR

NOTE: When the upper guides are raised or lowered, they must not deflect the blade front to back or sideways. This means that the guide bar must be parallel to the blade.

1. Lower guide bar until it is approximately 1-3/4 inches above table. Tighten guide bar lock screw.
2. Hold a square on table against guide bar as shown to check side to side squareness.

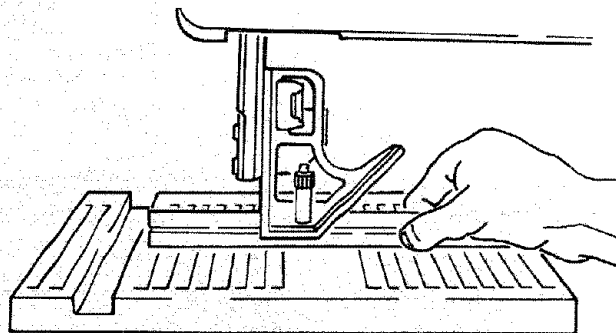

assembly

3. Hold square on table against guide bar as shown to check front to back squareness.

NOTE: Square must rest on the guide bar and not on the upper guide bracket. Note illustration.

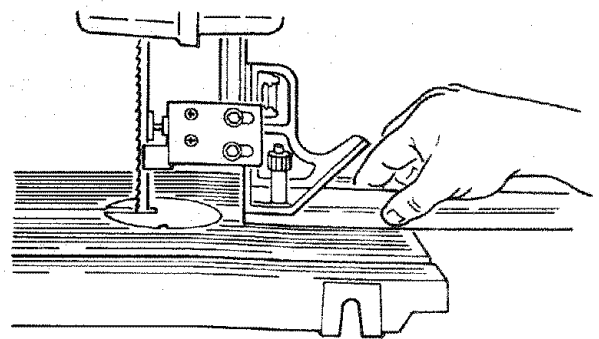

ADJUSTING FRONT TO BACK SQUARENESS

NOTE: When making adjustments, guide bar lock screw must be loosened. To check squareness it must be tightened.

- a. Loosen guide bar lock screw and lower guide bar until it rests on table. Leave lock screw loose.
- b. Loosen two hex head screws on the top of frame tube.
- c. Loosen lock nuts on guide bar bracket adjustment screws.

NOTE: Turning guide bar bracket adjustment screws clockwise will move guide bar toward front of saw. Turning screws counter clockwise will move guide bar to rear of saw.

- d. Turn guide bar bracket adjustment screws 1/4 turn using 5/32 inch set screw wrench.
- e. Tighten hex head screws on top of frame tube.
- f. Raise guide bar 1-3/4 inches and tighten guide bar lock screw.
- g. Check squareness. Readjust if necessary.
- h. Hold guide bar bracket adjustment screws with 5/32 inch set screw wrench and tighten lock nuts.

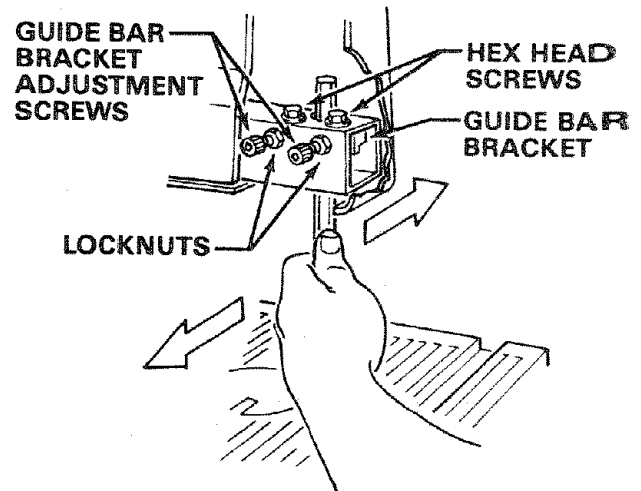

ADJUSTING SIDE TO SIDE SQUARENESS

NOTE: When making adjustments, guide bar lock screw must be loosened. To check squareness it must be tightened.

- a. Loosen guide bar lock screw and lower guide bar until it rests on table. Leave lock screw loose.
- b. Loosen two hex head screws on top of frame tube.
- c. Grasp guide bar as illustrated and move to the side needed to square it with table. This will slide the guide bar bracket into position.
- d. Tighten hex head screws on the top of frame tube.
- e. Raise guide bar 1-3/4 inches and tighten guide bar lock screw.
- f. Check squareness. Readjust if necessary.

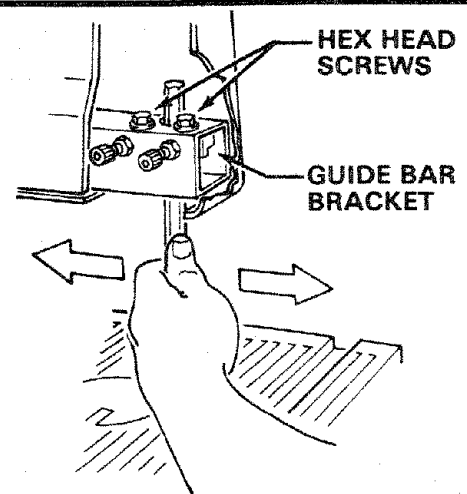

assembly

ADJUSTING UPPER BLADE GUIDE ASSEMBLY

NOTE: The upper and lower blade guides support the blade and keep it from twisting during operation. An adjustment is necessary when blades are changed or replaced.

1. Loosen two hex head screws in upper blade guide assembly and slide assembly forward in the slots until the front edge of the blade guides are approximately $1/32$ " from the GULLET of the saw blade.
2. Tighten two hex head screws.

NOTE: It may be necessary to back out thrust roller adjustment to allow thrust roller to move back from blade to get $1/32$ " clearance from the gullet to edge of blade guide.

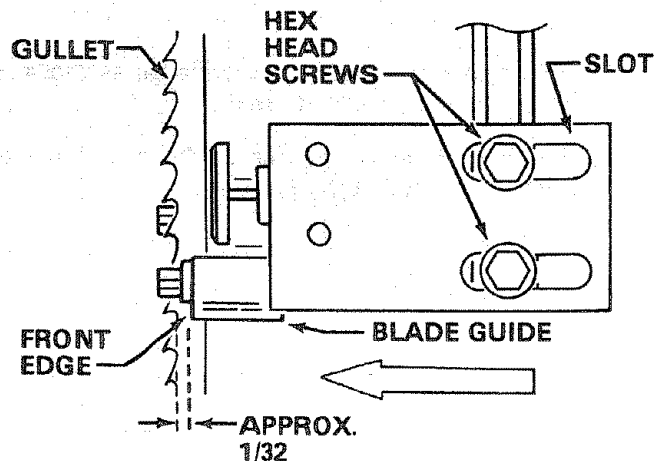

ADJUSTING UPPER BLADE GUIDES

1. Loosen the two cap screws that lock the upper blade guides and press the two guides evenly against the sides of the blade but do not pinch the blade. Release the guides and rotate the upper wheel slightly clockwise moving the blade downward. Make sure one guide is not further away from the blade than the other. Tighten both cap screws.

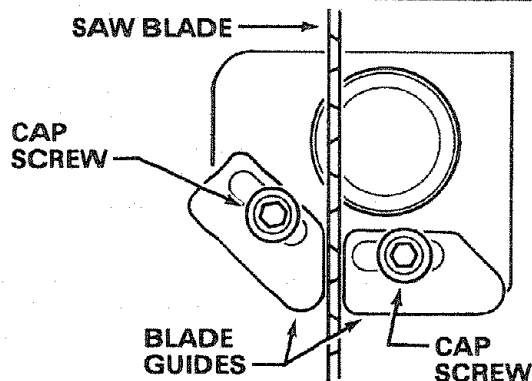

ADJUSTING UPPER THRUST ROLLER

NOTE: The thrust rollers support the blade from the rear and will rotate when the blade is pushed against them while you are cutting. As soon as you stop cutting, the rollers should stop rotating.

1. To be sure the thrust roller is properly supporting the blade, turn the thrust roller adjustment screw using $5/32$ " setscrew wrench so that the roller moves toward the blade and almost touches.
2. While turning the upper wheel clockwise by hand, adjust the thrust roller until it barely touches the blade and starts to rotate. Now move the roller back slightly until it stops rotating while upper wheel is rotated.
3. Tighten lock nut while holding thrust roller adjustment screw with setscrew wrench.

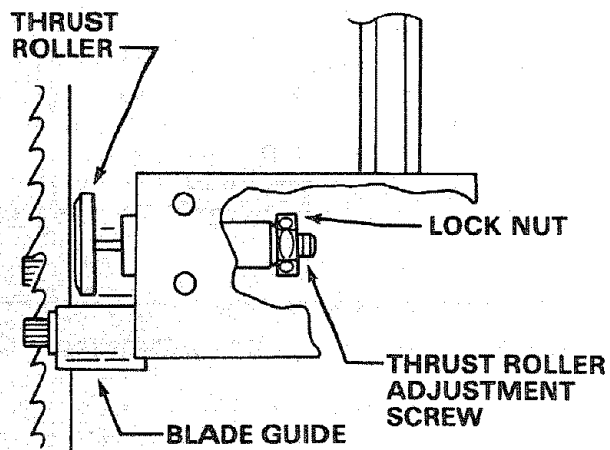

ADJUSTING LOWER BLADE GUIDE ASSEMBLY

1. Turn lock nuts on lower blade guide assembly counter clockwise and move lower blade guide assembly forward until the front edge of the blade guides are approximately $1/32$ " from the GULLET of the saw blade.

NOTE: It may be necessary to back out thrust roller adjustment to allow thrust roller to move back from the blade to get $1/32$ " clearance from the gullet to edge of blade guide.

2. Tighten lock nuts.

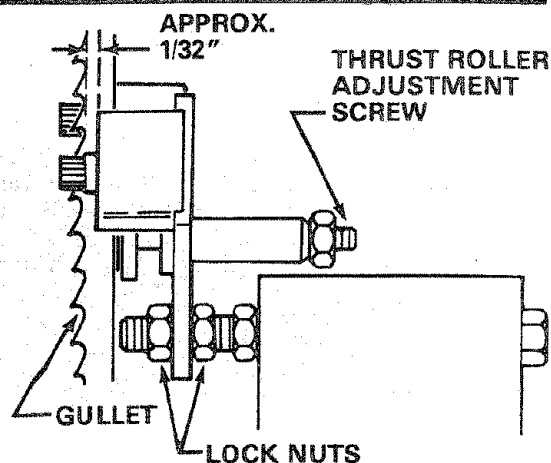

assembly

ADJUSTING LOWER BLADE GUIDES

1. Loosen the two cap screws that lock the lower blade guides and press the two guides evenly against the sides of the blade but do not pinch the blade. Release the guides and rotate the upper wheel slightly clockwise moving the blade downward. Make sure one guide is not further away from the blade than the other. Tighten both cap screws.

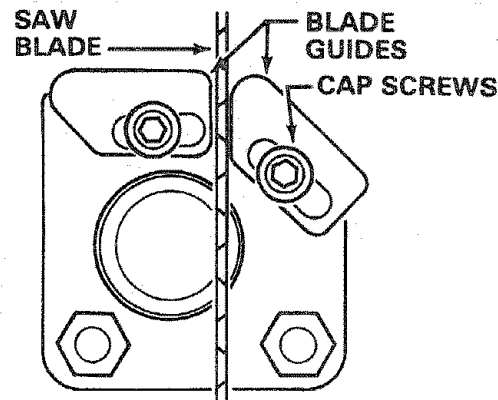

ADJUSTING LOWER THRUST ROLLER

1. To be sure the thrust roller is properly supporting the blade, turn the thrust roller adjustment screw using 5/32" setscrew wrench so that the roller moves toward the blade and almost touches.
2. While turning the upper wheel clockwise by hand, adjust the thrust roller until it barely touches the blade and starts to rotate. Now move the roller back slightly until it stops rotating while upper wheel is rotated.
3. Tighten lock nut while holding thrust roller adjustment screw with setscrew wrench.
4. Rotate the upper wheel a few times by hand and check the blade guides and thrust rollers. Make re-adjustments if necessary.

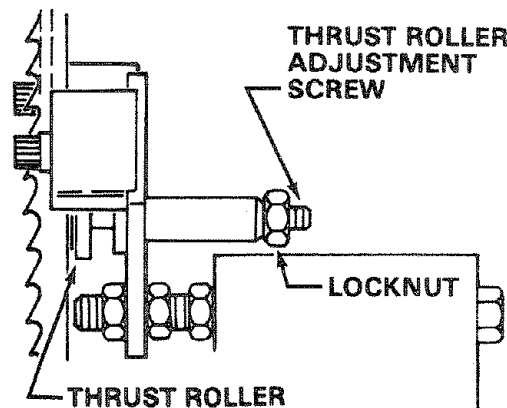

ADJUSTING THE TABLE

1. Replace the blade guard on the upper guide assembly and tighten screws.
2. Locate the table insert and place it in the opening in the table.
3. Locate a 1/4 - 20 x 1" truss head screw, a flat washer, and a 1/4 - 20 wing nut among loose parts. Insert screw into hole in table top as illustrated.
4. From the underside of the table, install washer and wing nut onto the truss head screw and tighten finger tight. This will keep the table flat and in alignment.
5. Replace the cover.

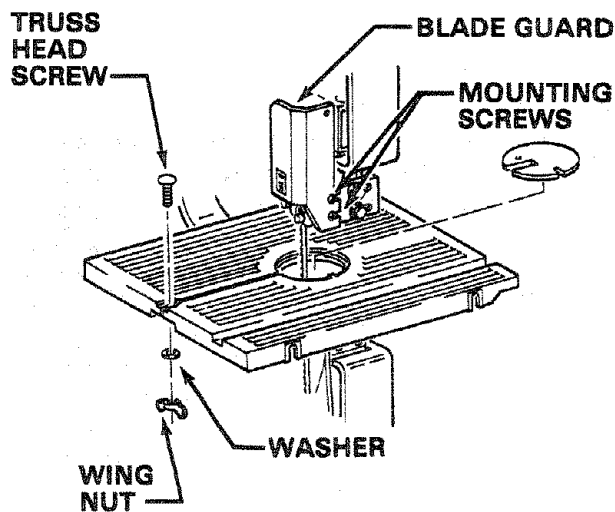

6. Blade should be in approximate center of slot in insert.
7. If blade runs to one side, loosen hex head screws that mount table to trunnion and shift table to center blade in table insert.
8. Tighten screws.

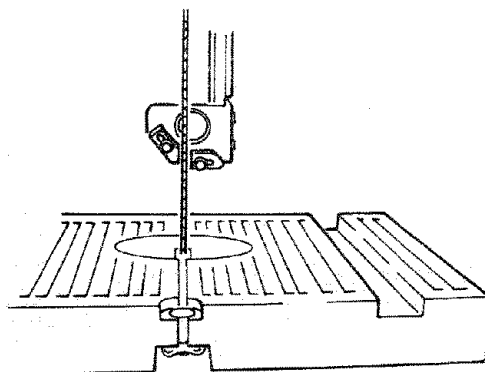

getting to know your band saw

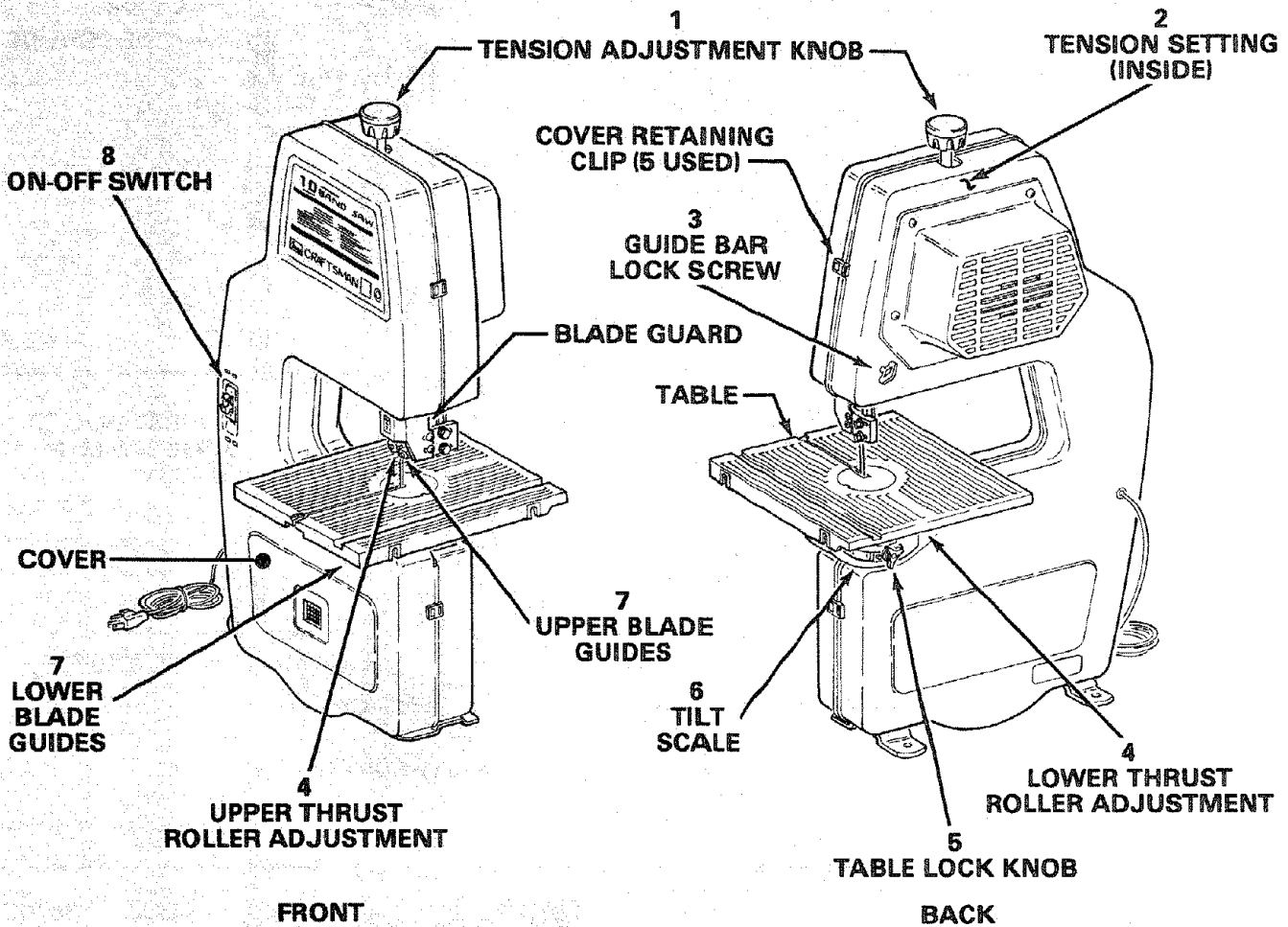

1. **TENSION ADJUSTMENT KNOB**... Tightening the knob will increase the tension on the blade. Loosening it will decrease the tension.
2. **TENSION SETTING**... The marking indicates the correct blade tension for the blade. For example, when installing the blade, tighten the tension adjustment knob until the indicator washer is pointing to the marking on the inside of cover.
3. **GUIDE BAR LOCK SCREW**... The upper blade guides should just clear the workpiece while cutting. Always adjust the upper guide assembly and lock the guide bar by tightening the guide bar lock screw before turning on the band saw.
4. **THRUST ROLLER ADJUSTMENT**... Turning the adjustment screw moves the thrust roller in or out to support the blade from the rear while cutting.
5. **TABLE LOCK KNOB**... Turning the knob allows the table to be tilted and locks it in place.
6. **TILT SCALE**... Shows degree table is tilted.
7. **BLADE GUIDES**... Supports the blade and keeps it from twisting during operation. An adjustment is necessary when blades are changed or replaced.
8. **ON-OFF SWITCH**... See below and next page.

ON-OFF SWITCH

The On-Off Switch has a locking feature. THIS FEATURE IS INTENDED TO PREVENT UNAUTHORIZED AND POSSIBLY HAZARDOUS USE BY CHILDREN AND OTHERS.

1. Insert key into switch.

NOTE: Key is made of yellow plastic.

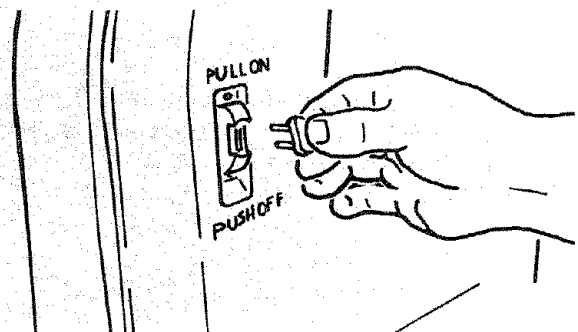

getting to know your band saw

2. To turn machine on, insert finger under switch lever and pull end of switch out.

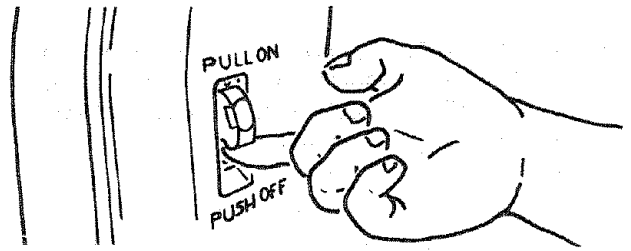

3. To turn machine OFF . . . PUSH lever in.

NEVER LEAVE THE MACHINE UNATTENDED UNTIL IT HAS COME TO A COMPLETE STOP.

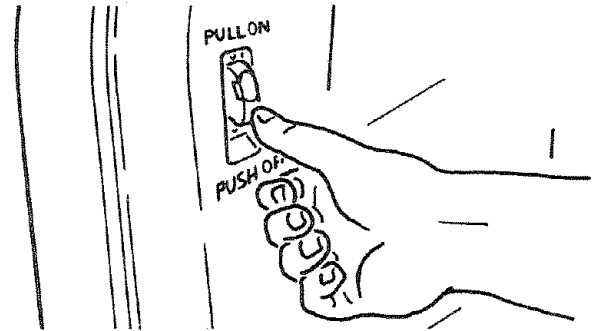

4. To lock switch in OFF position . . . hold switch IN with one hand . . . REMOVE key with other hand.

WARNING: FOR YOUR OWN SAFETY, ALWAYS LOCK THE SWITCH "OFF" WHEN MACHINE IS NOT IN USE . . . REMOVE KEY AND KEEP IT IN A SAFE PLACE . . . ALSO . . . IN THE EVENT OF A POWER FAILURE (ALL OF YOUR LIGHTS GO OUT) TURN SWITCH OFF . . . REMOVE THE KEY AND STORE IT REMOTE FROM BAND SAW. THIS WILL PREVENT THE MACHINE FROM STARTING UP AGAIN WHEN THE POWER COMES BACK ON.

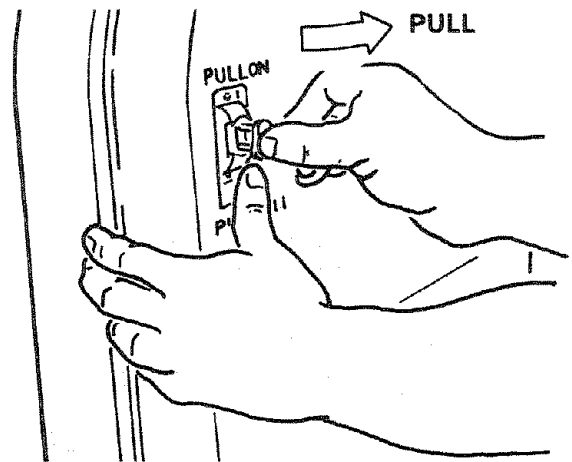

basic band saw operation

A band saw is basically a "curve cutting" machine. It is also used for straight-line cutting operations such as cross-cutting, ripping, mitering, beveling, compound cutting, and resawing. It is not capable of doing inside cutting.

This band saw is not designed to cut metal.

SAWING

1. Adjust the upper guide assembly to just clear the workpiece.
2. Use both hands while feeding the work into the blade. Hold the workpiece firmly against the table. Use gentle pressure, and do not force the work, but allow the blade to cut.

3. The smallest diameter circle that can be cut out is determined by the width of the blade. For example, a 1/4" wide blade will cut a minimum diameter of approximately 1-1/2". (See Chart)

BLADE SELECTION GUIDE FOR MINIMUM CIRCLE CUTTING

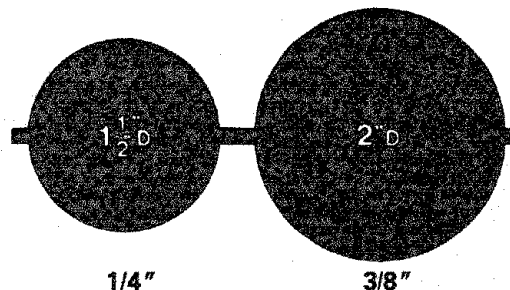

BLADE SIZE

$1/4''$

$3/8''$

maintenance

WARNING: FOR YOUR OWN SAFETY, TURN SWITCH "OFF" AND REMOVE PLUG FROM POWER OUTLET BEFORE MAINTAINING OR LUBRICATING YOUR BAND SAW.

TIRES

Pitch and sawdust that accumulate on the tires should be removed with a stiff brush or scraped off with a piece of wood. Do not use a sharp knife or any kind of solvent.

When the tires become worn they should be replaced. When replacing the tires, stretch them around the wheels but do not glue them on.

GENERAL

Keep your Band Saw clean.

Remove sawdust from the inside.

Do not allow pitch to accumulate on the table, blade insert, blade guides, or thrust rollers. Clean them with Craftsman Gum and Pitch Remover.

Apply a thin coat of automobile-type wax on the table so the wood slides easily while cutting. Also apply wax to the inside surfaces of the trunnion.

MOTOR

Frequently vacuum or blow out any sawdust from the motor.

If the power cord is worn, cut, or damaged in any way, have it replaced immediately.

LUBRICATION

All of the BALL BEARINGS are packed with grease at the factory. They require no further lubrication.

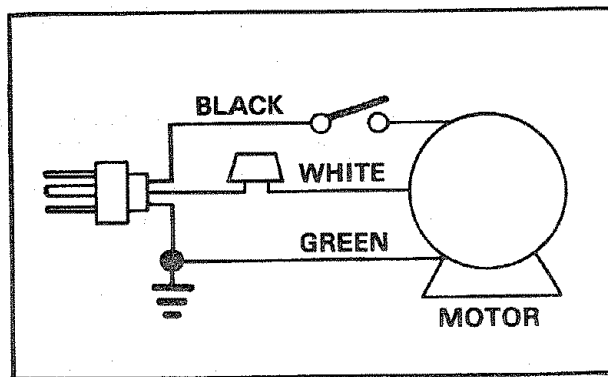

RECOMMENDED ACCESSORIES

Item	Cat. No.
Floor Base.....	9-22213
Miter Gauge.....	9-22574
Rip Fence.....	9-23433
Blades.....	See Catalog
Steel Leg Set.....	9-22236
Circle Cutting Attachment.....	9-24301
Table Extension.....	9-24302
Power Tool Know How Handbooks	
Radial Saw.....	9-2917
Table Saw.....	9-2918

The above recommended accessories are current and were available at the time this manual was printed.

troubleshooting

WARNING: FOR YOUR OWN SAFETY, TURN SWITCH "OFF" AND REMOVE PLUG FROM POWER SOURCE OUTLET BEFORE TROUBLESHOOTING YOUR BAND SAW.

TROUBLE	PROBABLE CAUSE	REMEDY
Motor will not run.	<ol style="list-style-type: none"> 1. Defective On-Off switch. Defective switch cord. Defective switch box receptacle. 2. Motor Defective. 	<ol style="list-style-type: none"> 1. Replace defective parts before using Band Saw again. 2. Consult Sears Service. Any attempt to repair this motor may create a HAZARD unless repair is done by a qualified service technician. Repair service is available at your nearest Sears Store.
Blade does not run in the approximate center of the upper wheel.	<ol style="list-style-type: none"> 1. Not tracking properly. 	<ol style="list-style-type: none"> 1. Adjust tracking, see Assembly Section, "Tracking the Blade."
Blade does not run in the approximate center of the lower wheel.	<ol style="list-style-type: none"> 1. Upper wheel not positioned correctly on shaft. 	<ol style="list-style-type: none"> 1. Reposition the wheel, see Assembly Section, "Tracking the Blade."
Band Saw slows down when cutting.	<ol style="list-style-type: none"> 1. Cutting too small a radius. 2. Dull blade. 	<ol style="list-style-type: none"> 1. Stop feeding, and back up to the material slightly, until the band saw speeds up. 2. Replace blade.
Blades breaking.	<ol style="list-style-type: none"> 1. Too much tension. 2. Kink in blade caused by cutting too small a radius or turning the material too fast when cutting. 	<ol style="list-style-type: none"> 1. Adjust tension. See Getting To Know Your Band Saw "Tension Setting". 2. Use correct cutting technique. See Basic Band Saw Operation Section.

**FIGURE 1
SUPPLIED WITH MODEL 113.244420**

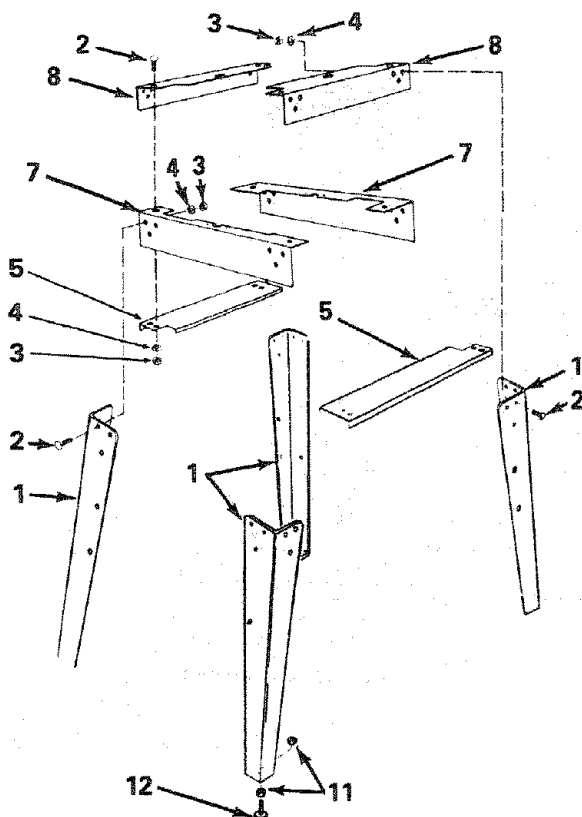

Key No.	Part No.	Description
1	62614	Leg
2	60314	†*Screw Truss Hd. 1/4-20 x 5/8
2	STD541025	†*Nut Hex 1/4-20
4	STD551225	†*Lockwasher, 1/4 External
5	68060	Channel, Support
7	68059	Stiffener, Side
8	62615	Stiffener, End
11	STD541050	†*Nut, Hex Hd. 1/2-13
12	803835	† Foot, Leveling
	69097	*Bag of Loose Parts
HARDWARE FOR MOUNTING TOOL		
	STD523110	†*Screw, Hex Hd. 5/16-18 x 1
	STD551131	†*Lockwasher Ext. 5/16
	STD541231	†*Nut, Hex 5/16-18
	STD551031	†*Washer 11/32 ID

* Standard Hardware Item — May Be Purchased Locally
† All Parts Contained In Loose Parts Bag

CRAFTSMAN 10-INCH BAND SAW, MODEL 113.244400 & 113.244420

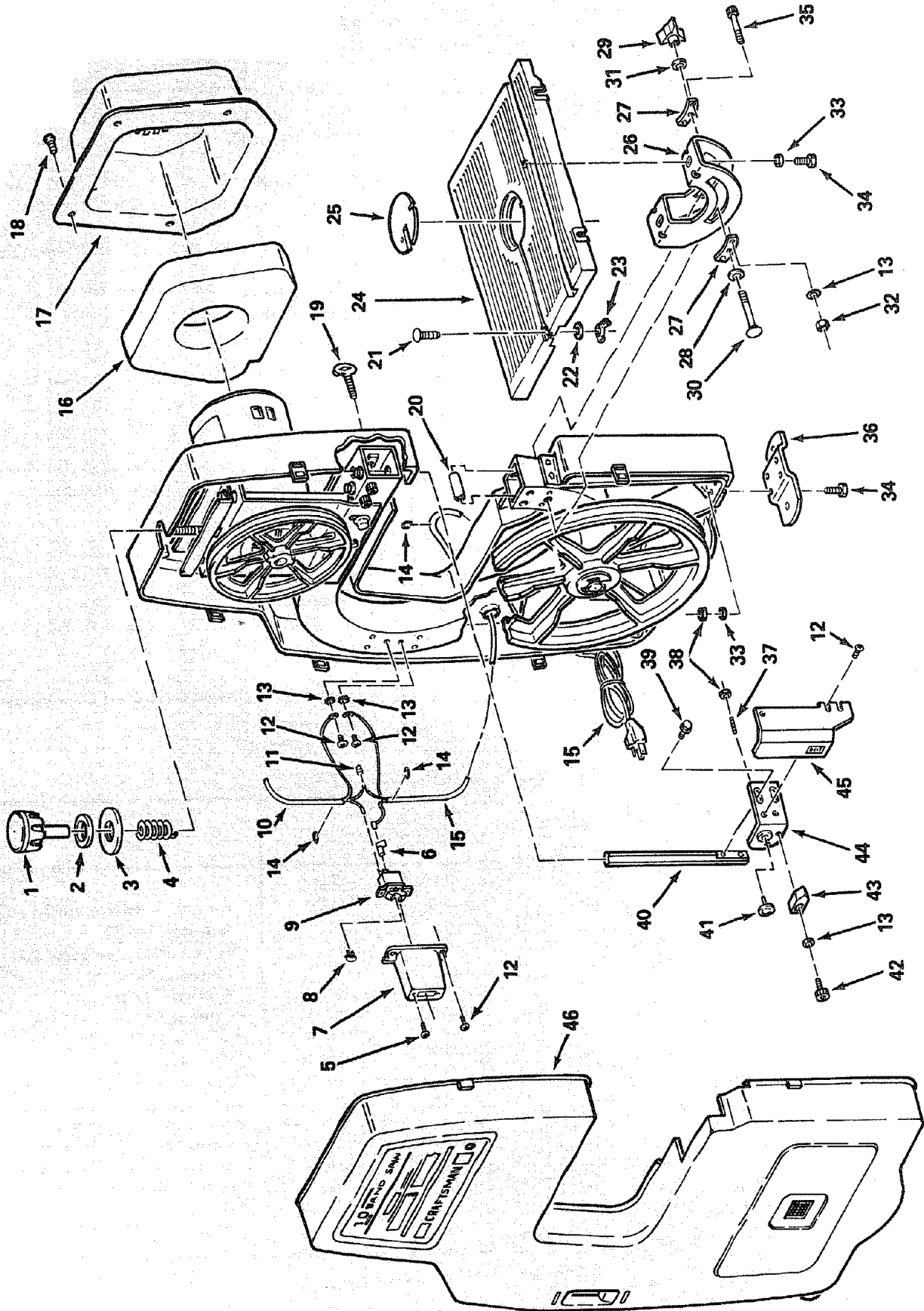

FIGURE 2

CRAFTSMAN 10-INCH BAND SAW, MODEL 113.244400 & 113.244420

Always order by Part Number — not by Key Number

FIGURE 2 PARTS LIST

KEY NO.	PART NO.	NAME
1	69031	Knob Asm, Tension
2	60386	Washer, 15/32 x 1-1/2 x 1/8
3	60430	Washer .47 x 2.5 x .06
4	69109	*Spring, Tension
5	STD600603	*Screw, Pan Cross Type T6-32 x 3/8
6	63467	Cap-Flag Terminal
7	69118	Cover, Switch
8	60256	Key, Switch
9	62442	Switch
10	69119	Cord
11	STD375006	*Connector, Wire
12	STD601103	*Screw, Pan Rec Type T 10-32 x 3/8
13	STD551210	*Lockwasher Ext. N10
14	30574	Ring Hog
15	69123	Cord with Plug
16	69128	Seal, Motor Foam
17	69127	Cover, Motor
18	60419	Screw Pan Hd. Plastite 8-16 x 1/2
19	60321	Screw, Thumb 5/16 - 18 x 1-1/2
20	60432	Spacer 7/16 ID x 1.800
21	60323	Screw, Truss Hd 1/4 - 20 x 1
22	9414920	Washer 17/64 x 5/8 x 1/16
23	STD541625	*Nut, Wing 1/4-20
24	69129	Table

KEY NO.	PART NO.	NAME
25	69133	Table Insert
26	69120	Trunnion
27	69121	Guide, Trunnion
28	60076	Washer .505 x 7/8 x 1/16
29	63387	Knob
30	109751	Bold Crge 5/16 - 18 x 2-3/4
31	60437	Washer 21/64 x 7/8 x 1/8
32	STD541110	*Nut Hex 10-32
33	STD551131	*Lockwasher 5/16
34	STD523110	Screw Hex Hd 5/16 - 18 x 1
35	60431	Screw Soc Cap 10-32 x 2-1/2
36	69084	Foot, Frame
37	139377	Screw Hex Soc Set 5/16 - 18 - 1
38	STD541031	Nut Hex 5/16 - 18
39	273229	Screw Hex Type T 1/4 - 20 x 1/2
40	69110	Bar Guide
41	18232	Roller, Blade Thrust
42	193250	Screw Hex Soc Cap 10-32 x 7/8
43	69114	Guide, Blade
44	69112	Bracket, Asm. Upper
45	69115	Guard, Blade
46	69126	Cover Asm. Front
—	69131	Owners Manual (Not Illustrated)
—	69132	Bag Of Loose Parts (Not Illustrated)

* Standard Hardware Item — May Be Purchased Locally.

† Stock Item — May be secured through the Hardware Department of most Sears or Simpsons-Sears Retail Stores or Catalog Order Houses.

CRAFTSMAN 10-INCH BAND SAW, MODEL 113.244400 & 113.244420

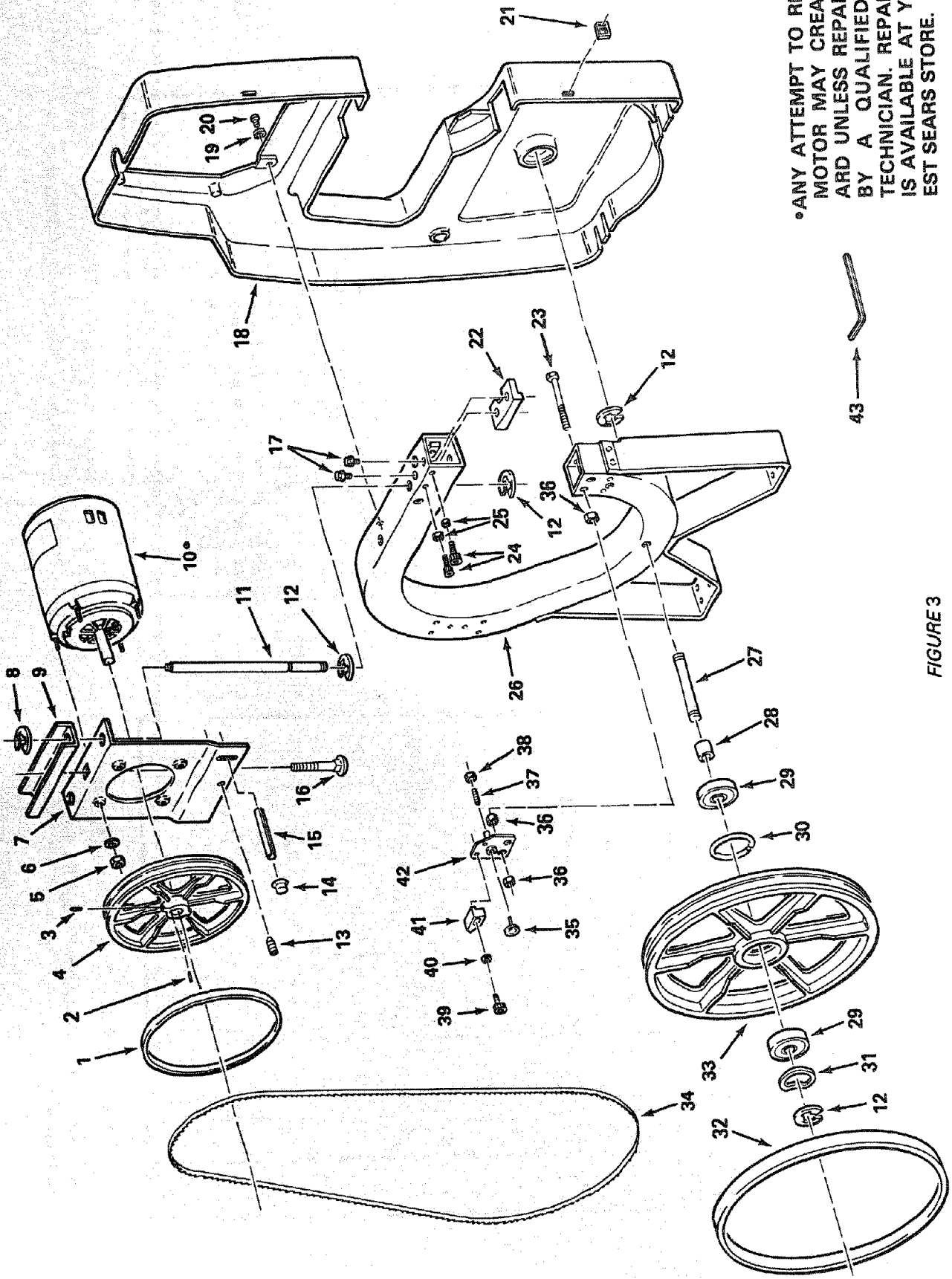

• ANY ATTEMPT TO REPAIR THIS MOTOR MAY CREATE A HAZARD UNLESS REPAIR IS DONE BY A QUALIFIED SERVICE TECHNICIAN. REPAIR SERVICE IS AVAILABLE AT YOUR NEAREST SEARS STORE.

FIGURE 3

**CRAFTSMAN 10-INCH BAND SAW, MODEL 113.244400 & 113.244420
FIGURE 3 PARTS LIST**

KEY NO.	NAME
1	Tire
2	*Key, Square 3/16 x 1-1/8
3	*Screw Hex Soc Set 5/16 - 18 x 5/8
4	Wheel, Drive
5	*Nut, Hex 8-32
6	*Lockwasher Ext. N8
7	Motor Mount Assembly
8	*Ring, Retaining 1/2
9	Bracket Guide Rod
10	*Motor
11	Rod, Guide
12	*Ring, Retaining 5/8
13	Screw Set Hex Cup 5/16 - 18 x 3/4
14	Cap, Hub
15	Pin Roll 1/4 x 3-1/4
16	Bolt Crge 7/16 - 14 x 3
17	Screw Hex Type T 1/4-20 x 1/2
18	Cover, Rear
19	*Washer 13/64 x 7/16 x 1/16
20	*Scr Pan Rec Type T 10-32 x 1/2
21	Latch
22	Bracket, Guide Bar

KEY NO.	NAME
23	Screw Hex Hd 1/4 - 20 x 3-1/4
24	Scr Soc Hd 10-32 x 5/8
25	*Nut Hex 10-32
26	Frame Assembly
27	Shaft Wheel
28	Spacer
29	*Ball Bearing
30	Ring, Retaining
31	Washer, Spring
32	Tire
33	Wheel Idler
34	†Blade, Band Saw 1/4 x 72-5/8
35	Roller, Blade Thrust
36	Nut Hex 1/4 - 20
37	Screw Hex Soc Set 5/16-18 x 1
38	Nut Hex 5/16-18
39	Screw Hex Soc Cap 10-32 x 7/8
40	*Lockwasher Int N10
41	Guide, Blade
42	Bracket Asm Lower
43	†Wrench Hex "L" 5/32

*Standard Hardware Item — May Be Purchased Locally.

†Stock Item — May be secured through the Hardware Department of most Sears Retail Stores or Catalog Order Houses.

Sears

*owners
manual*

SERVICE

**MODEL NO.
113.244400**

SAW ONLY

**MODEL NO.
113.244420**

SAW WITH LEGS

**HOW TO ORDER
REPAIR PARTS**

10-INCH BAND SAW

Now that you have purchased your 10-Inch Band Saw should a need ever exist for repair parts or service, simply contact any Sears Service Center and most Sears, Roebuck and Co. stores. Be sure to provide all pertinent facts when you call or visit.

The model number of your 10-Inch Band Saw will be found on a plate at the right-hand side of the saw.

WHEN ORDERING REPAIR PARTS, ALWAYS GIVE THE FOLLOWING INFORMATION:

PART NUMBER	PART DESCRIPTION
MODEL NUMBER	NAME OF ITEM
113.244400	10-Inch Band Saw
or	
113.244420	

All parts listed may be ordered from any Sears Service Center and most Sears stores. If the parts you need are not stocked locally, your order will be electronically transmitted to a Sears Repair Parts Distribution Center for handling.

Sold by SEARS, ROEBUCK AND CO., Chicago, IL. 60684 U.S.A.