

Custom Options Guide and Installation Instructions

With Custom Panel Dimensions
and Trim Kit Installation Instructions

These Monogram refrigerators and freezers are designed to be customized with decorator door and grille panels. Field installed panels are required.

Factory installed trim will accommodate 1/4" thick custom panels or optional Lexan® and stainless steel panel kits.

Optional trim kits allow an even broader range of custom appearance options.

Read this booklet carefully to accomplish the desired appearance and to insure a trouble free installation.

This booklet contains information and illustrations to demonstrate custom possibilities. Custom door and grille panel sizes vary to accommodate the kit being used. Dimensions for each application are included and can be faxed or sent to the cabinet manufacturer so that the panels can be constructed accurately.

36" Refrigerators and 36" Freezers

ZIR36N LH – All Refrigerator

ZIR36N RH – All Refrigerator

ZIF36N LH – All Freezer

ZIF36N RH – All Freezer

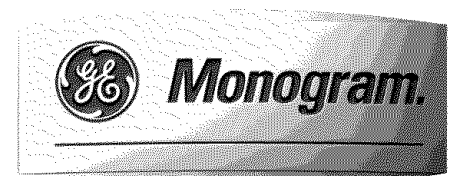

Before you begin – Read these instructions completely and carefully.

IMPORTANT – Save these instructions for local inspector’s use.

IMPORTANT – OBSERVE ALL GOVERNING CODES AND ORDINANCES.

Note to Installer – Be sure to leave these instructions with the Consumer.

Note to Consumer – Keep these instructions with your Owner’s Manual for future reference.

⚠ WARNING This appliance must be properly grounded. See “Grounding the Refrigerator,” page 12.

⚠ ATTENTION Cet appareil doit être correctement mis à la terre. Consulter « Mise à terre du réfrigérateur », page 12.

If you received a damaged product, you should immediately contact your dealer or builder.

Proper installation is the responsibility of the installer. Product failure due to improper installation is not covered under the GE Appliance Warranty. See the Owners’ Manual for warranty information.

For Monogram local service in your area,
1.800.444.1845.

For Monogram service in Canada,
1.800.561.3344

For Monogram Parts and Accessories,
call 1.800.626.2002.

⚠ CAUTION
Due to the weight and size of this refrigerator, and to reduce the risk of personal injury or damage to the product – THREE PEOPLE ARE REQUIRED FOR PROPER INSTALLATION.

⚠ PRUDENCE
À cause du poids et de la taille de ce réfrigérateur et pour réduire le risque de blessure et de dommages, IL FAUT TROIS PERSONNES POUR FAIRE L’INSTALLATION CORRECTEMENT.

⚠ WARNING

- Use this appliance only for its intended purpose.
- Immediately repair or replace electric service cords that have become frayed or damaged.
- Unplug the refrigerator before cleaning or making repairs.
- Repairs should be made by a qualified service technician.

⚠ ATTENTION

- Il ne faut utiliser cet appareil que pour l’usage pour lequel il a été construit.
- Il faut réparer ou remplacer immédiatement tout cordon d’alimentation électrique effiloché ou endommagé.
- Débrancher le réfrigérateur avant le nettoyage ou toute intervention.
- Les réparations doivent être faites par un technicien qualifié.

Contents

Design Information	
Flush or Semi-Flush Enclosure Installations	3
Enclosure Cutout and Product Dimensions	3
Clearances	4
Side By Side Installation of Freezer and Refrigerator	4
Installation Examples	4, 5
Frameless Cabinets	5
Accessory Panel Kits	5
Advance Planning Appearance Options	5
Models Available	6
Trim Kit Descriptions	6
Custom Panel Dimensions	
Product and Cutout Information	7
1/4” Thick Custom Panels on 1/4” backing	8
3/4” Thick Panels with Supplied Handle	9
3/4” Thick Panels with Custom Handle	10
Side Panel or Filler Options	11
Installation Instructions	12-18
Trim Kits	
ZGC2 Trim Kit, Grille Panel Frame Adjustment	19
ZKHR1 Trim Kit (for 1/4” Panels), Support for Custom Handles	20-21
ZKTR36LH/ZKTR36RH Trim Kit, 3/4” Custom Panels	22-25
ZKHTR1 Trim Kit (for 3/4” Panels), Support for Custom Handles	26-28
ZKHRSS1 Trim Kit (for 1/4” Panels), Tubular Stainless Steel Handles	29-32
ZKHTRSS1 Trim Kit (for 3/4” Panels), Tubular Stainless Steel Handles	33-34
ZUG75 Trim Kit, Unified 3/4” Grille Panel Kit	35-40

Advance Planning

Flush or Semi-Flush Enclosure Installations

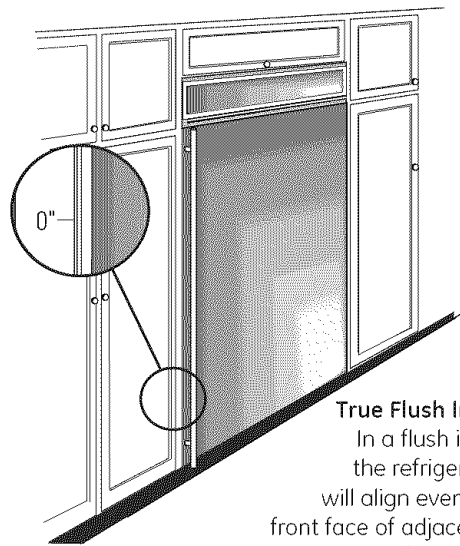

True Flush Installation

In a flush installation, the refrigerator doors will align evenly with the front face of adjacent cabinet doors. The refrigerator blends into the surrounding cabinetry.

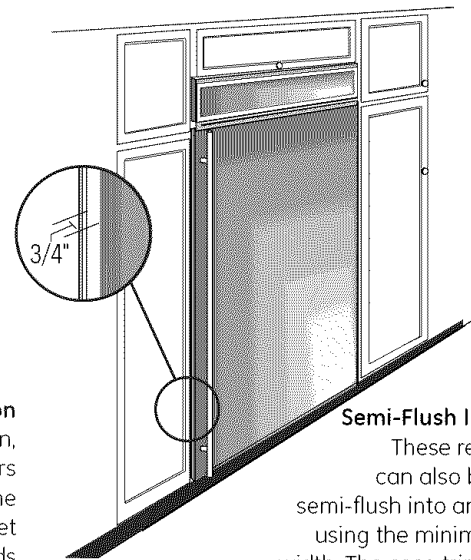

Semi-Flush Installation

These refrigerators can also be installed semi-flush into an enclosure using the minimum cutout width. The case trim creates a frame around the opening.

Monogram built-in refrigerators and freezers can be installed flush with typical 24-3/4" deep cabinetry.

When installed semi-flush, the case trim will conceal slight gaps around the enclosure. The refrigerator or freezer will project forward approximately 3/4" beyond the front face of surrounding cabinetry.

In any installation situation, a wide range of appearance options can be accomplished through the use of one or more trim kits. See trim kit descriptions and appearance options on page 6.

Side Panel Requirements:

- Side panels are not required whenever the refrigerator is installed into an enclosure or between pantry and oven cabinets.
- Side panels are required whenever the sides of the refrigerator are exposed.
- Side panel sizes vary depending on the type of installation being made.

To accomplish an attractive installation, you must:

1. Determine the need for side panels.
2. Determine side panel thickness.
3. Order matching side panels from the cabinet manufacturer. Be sure to provide the exact dimensions.

Enclosure Cutout and Product Dimensions

- To achieve a flush fit the finished cutout width must be at least 36" wide.
- A semi-flush installation requires 35-1/2" min. finished cutout width.
- The electrical and water locations must be located as shown for either type of installation.

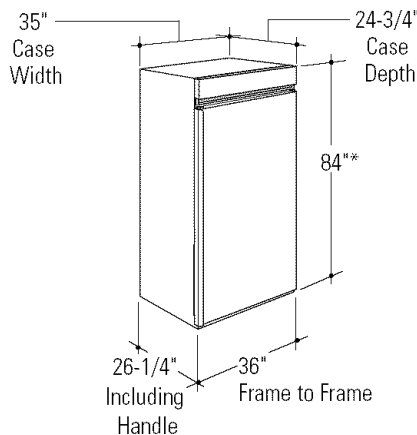

*Shipped at 84" installation height.
Can be adjusted to 83-1/2" or 84-1/2" with grille panel kits.

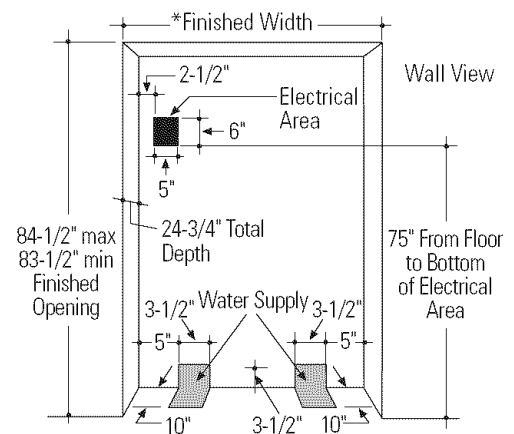

*36" Min. for a flush installation
35-1/2" Min. for a semi-flush installation

NOTE: Additional cutout width may be required when side panels are used. Add side panel thickness to the finished cutout to calculate rough-in width. See installation examples on the following page.

Clearances

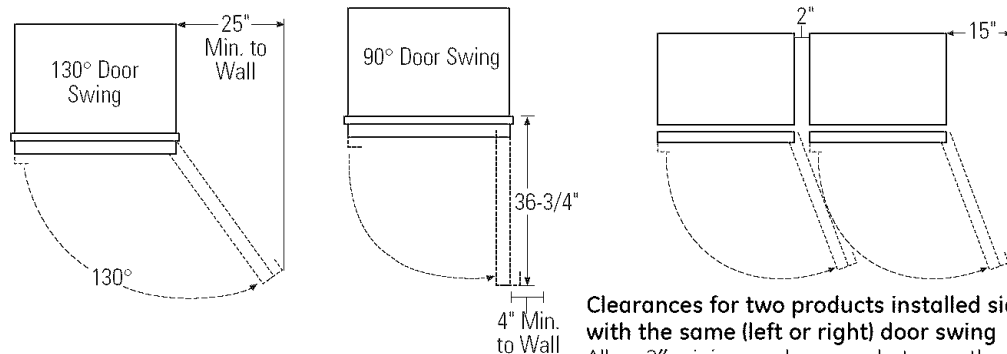

Factory set for a 130° door swing. Order WX14X99 adjustable door stop to reduce swing to as little as 90°.

When Installed into a corner:

Allow 25" for a full 130° door swing. Allow 15" for pan removal. Allow 4" min. clearance when door swing is adjusted to a 90° opening for pan access, but pan removal is restricted.

Clearances for two products installed side-by-side with the same (left or right) door swing

Allow 2" minimum clearance between the products to prevent door swing interference. Order the WX14X99 adjustable door stop to reduce the factory set 130° door swing. Allow 15" minimum to a wall to achieve full drawer extension and pan removal. Additional clearances are required when using custom handles and panels.

NOTE: ZUG75 Grille Panel Kit will not fit this installation.

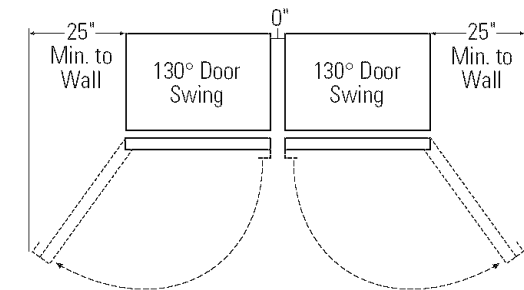

Clearances for Multiple Single Door Installations

In a side-by-side installation of a left and right door swing product, no clearance between the units is required. If you are installing 3/4" thick custom panels, order ZUG75 Unified Grille Panel Kit for one continuous grille panel.

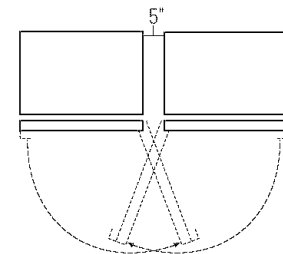

Clearances for two products installed side-by-side with right and left side hinges together

Allow 5" minimum between the two products to prevent one door from striking the other. Use the WX14X99 adjustable door stop to reduce the factory set 130° door swing and to allow pan removal. Additional clearances are required when using custom handles and panels.

NOTE: ZUG75 Grille Panel Kit will not fit this installation.

Side By Side Installation Of Freezer And Refrigerator

For a complete food storage center, install a Monogram Freezer and Refrigerator side by side. Order ZUG75 Unified Grille Panel Kit for one continuous 3/4" panel.

- Electrical and water locations must be located as shown for either type of installation. A separate 115V, 60Hz, 20 amp power supply is recommended for each product.

NOTE: Additional cutout width may be required when side panels are used. Add side panel thickness to the finished cutout to calculate rough-in width. See installation examples below.

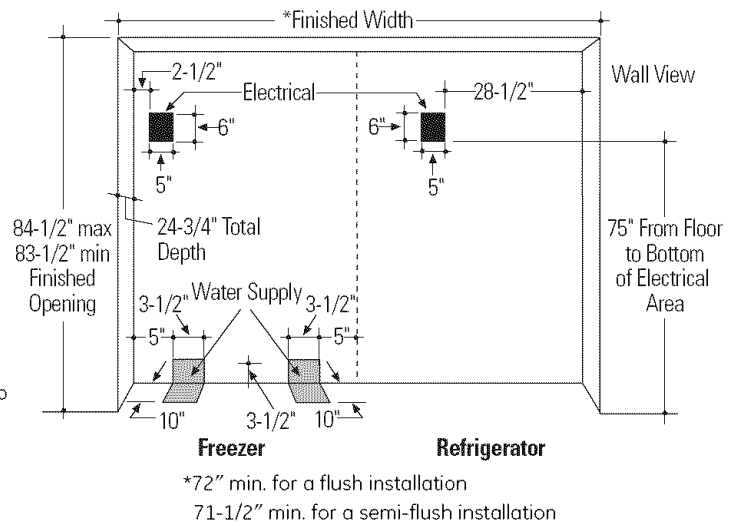

Installation Examples

Side panels are required whenever the sides of the product will be exposed.

1/2" to 3/4" side panels are normally set into place and fastened to adjacent cabinetry or back wall before rolling the refrigerator or freezer into the opening.

Therefore, the rough-in dimensions must allow for side panel thickness. In a flush and semi-flush installation, the finished dimension (width of the opening after side panels are installed) must accommodate the full width of the product. See page 11 for side panel sizes.

Design Information

36" Refrigerators, Freezers

Installation Between Base and Wall Cabinets

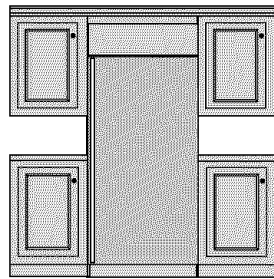

Refrigerator or Freezer

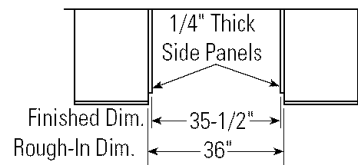

NOTE: 1/4" thick side panels can be inserted into the case trim, making the rough-in the same as the outside trim width, 36".

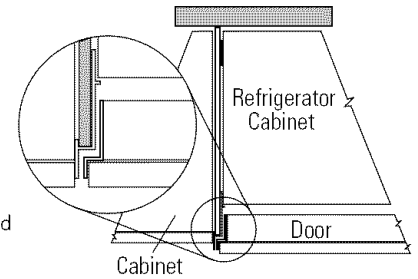

Installation At End-of-Run

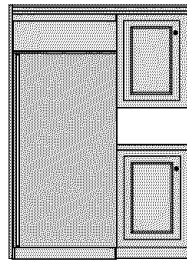

Refrigerator or Freezer

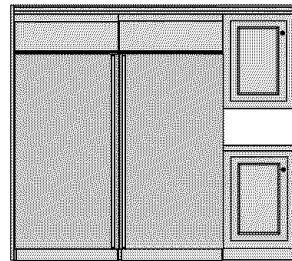
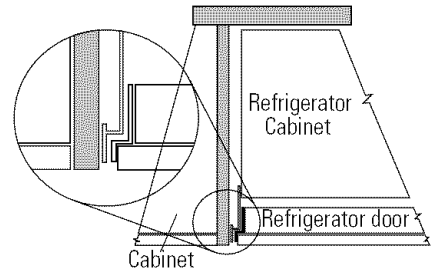
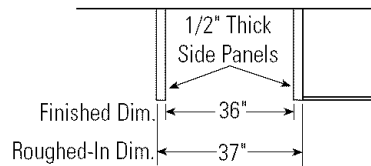

Refrigerator and Freezer installed side-by-side

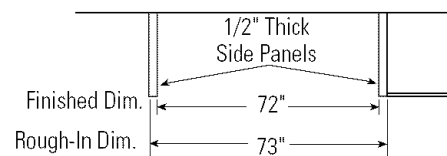

NOTE: 1/2" thick side panels shown. Side panels can be any thickness. Add side panel thickness to outside trim width, (36" or 72" for two models) to calculate the rough-in dimension. The leading (front) edge must be finished to match surrounding cabinetry.

Frameless Cabinets

Side panels, 1/2" minimum thickness are required when using frameless cabinets. The side panel acts as a spacer between the cabinet and the case trim and prevents interference with cabinet door swing. The leading (front) edge must be finished to match surrounding cabinetry.

1/2" To 3/4" Side Panels. Leading Edge Flush With Cabinet

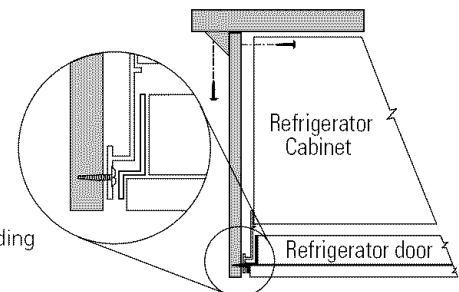

Accessory Panel Kits

These refrigerators and freezers require field installed door and grille panels. The factory installed trim will accept accessory panel kits. Black Lexan® and stainless steel kits are available. Panels are cut to size and ready to install. Panel kits must be ordered separately.

ZWBR36, Black Lexan® Panels
 ZWSR36, Stainless Steel Panels

Advance planning exterior appearance options

These refrigerators and freezers are designed to be customized with decorator door and grille panels. Field installed custom door and grille panels are required.

Door and grille panel sizes vary to accommodate the kit being used. Sizes are provided in this booklet.

CAUTION: Maximum door panel weight is 50 pounds.

Side panels must be used whenever the sides of the refrigerator will be exposed. Side panel sizes vary depending on the installation.

3/4" thick custom panels—Without trim kits

A raised panel design, screwed or glued to a 1/4" thick backing can be used. See page 8.

You should:

1. Select the appearance option.
2. Order the trim kit for that option.
3. Order the custom door and grille panels from the cabinet manufacturer. The exact dimension for each trim kit application is provided in this booklet. Find and pull out the page for your application and fax or send it to the cabinet manufacturer.
4. Determine the final installation situation and order matching side panels.

Design Information

36" Refrigerators, Freezers

Models available

ZIR36N RH, Refrigerator ZIF36N RH, Freezer
36" wide models with handle on left side, the door swings left to right.

ZIR36N LH, Refrigerator ZIF36N LH, Freezer
36" wide models with handle on right side, the door swings right to left.

Trim kit descriptions

ZGC2 – Provides 1/4" grille panel frame side pieces for 83-1/2" and 84-1/2" installation heights. The supplied grille panel frame is factory set for 84".

ZKHR1 – Provides the necessary framework to install a custom handle, *of your choice*, onto a 1/4" thick panel. (Handle not included.)

ZKHRSSI – Tubular stainless steel handle for 1/4" thick panel installation.

ZKHTR1 – Provides the necessary framework to install a custom handle, *of your choice*, onto a 3/4" thick panel. (Handle not included.) This kit must be used in combination with ZKTR36LH or ZKTR36RH.

ZKHTRSS1 – Tubular stainless steel handles for 3/4" thick panel installations. This kit must be used in combination with ZKTR36LH or ZKTR36RH.

ZKTR36LH (left opening models), ZKTR36RH (right opening models) – Provides for the installation of 3/4" thick custom door and grille panels. This kit provides a standard handle to fit 3/4" thick panels.

ZUG75 – For side by side installation of two products. This kit provides for the installation of a unified 3/4" custom grille panel to span the width of two products. Includes a trim strip to cover inside case trim for a more finished appearance. This kit must be used in combination with both the ZKTR36LH and ZKTR36RH.

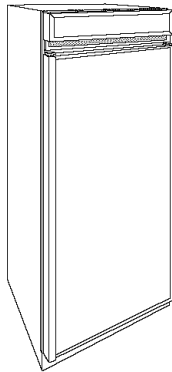

1/4" Panel with standard handles. No kits required.

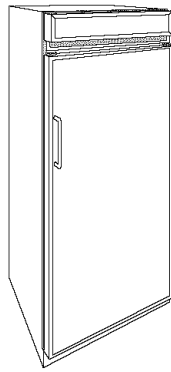

1/4" Custom panel with custom handles. Trim Kit ZKHR1.

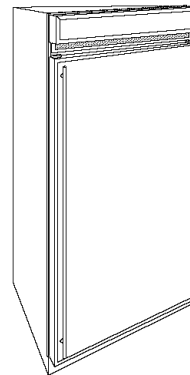

1/4" Custom panel with Tubular Stainless Steel handles, Trim Kit ZKHRSSI.

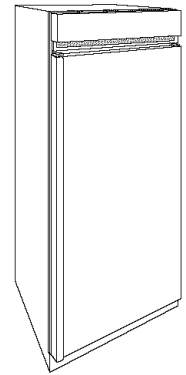

3/4" Custom panels with supplied handle. Trim Kit ZKTR36LH (or ZKTR36RH).

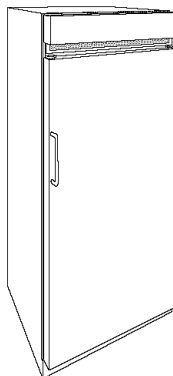

3/4" Custom panel with custom handle. Trim kits ZKTR36LH (or ZKTR36RH) and ZKHTR1.

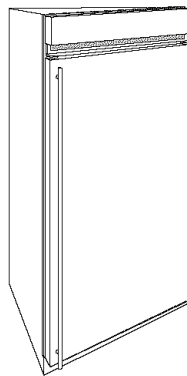

3/4" Custom panel with Tubular Stainless Steel handle, Trim Kits ZKTR36LH (or ZKTR36RH) and ZKHTRSS1.

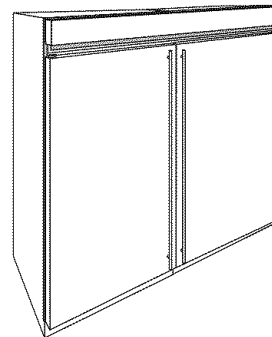

Side by side installation with 3/4" custom panels and unified custom grille panel. Trim Kits ZUG75, ZKTR36LH, ZKTR36RH.

Custom Panel Dimensions

36" Refrigerators, Freezers

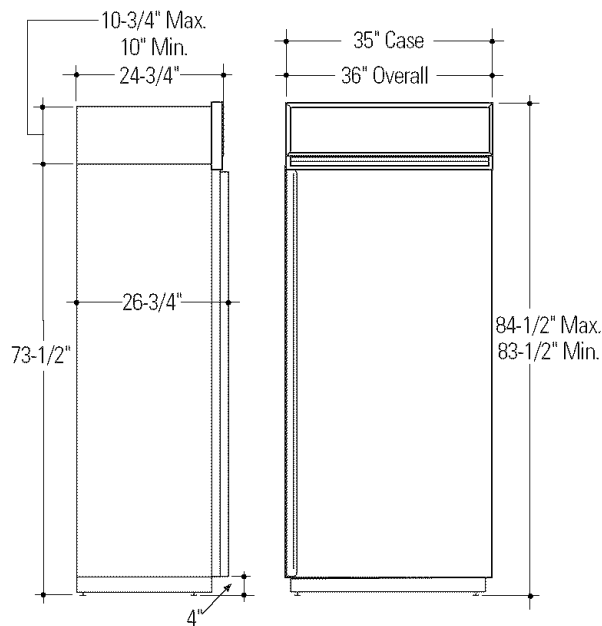

ZIR36N Refrigerator ZIF36N Freezer

Design Information

Designed to be installed flush or semi-flush with surrounding cabinetry. Cutout dimensions, clearances and side panel sizes are determined by the many installation options available. Side panels must be used whenever the sides of the refrigerator will be exposed. Side panels are not required when installed into an enclosure or between pantry and oven cabinets.

IMPORTANT – Side panels, 1/2" minimum thickness are required when using FRAMELESS CABINETS.

- Field installed custom panels, Lexan® or stainless steel panels are required. The door and grille panel sizes vary to accommodate the kit being used.
- The supplied toe kick is vented and must remain unobstructed for proper air circulation.

Optional Panel Kits:

- ZWBR36: Black Lexan® Panel Kit
- ZWWR36: White Lexan® Panel Kit
- ZWSR36: Stainless Steel Panel Kit

Optional Custom Trim Kits:

- ZKHR1: For installation of a custom handle of your choice onto a 1/4" Panel.
- ZKTR36LH or ZKTR36RH: For installation of a 3/4" thick custom panel.
- ZKHTR1: For installation of a custom handle of your choice onto a 3/4" thick panel. (This kit must be used in combination with ZKTR36LH or ZKTR36RH).
- ZKHRSS1: Tubular Stainless Steel handle for 1/4" thick panel.
- ZKHTRSS1: Tubular Stainless Steel handle for 3/4" thick panel.
- ZGC2: 1/4" grille panel frame side pieces for 83-1/2" and 84-1/2" installation heights. (Factory set for 84").
- ZUG75: Unified 3/4" Grille Panel for side by side installations. This kit must be used in combination with ZKTR36LH and ZKTR36RH kits.

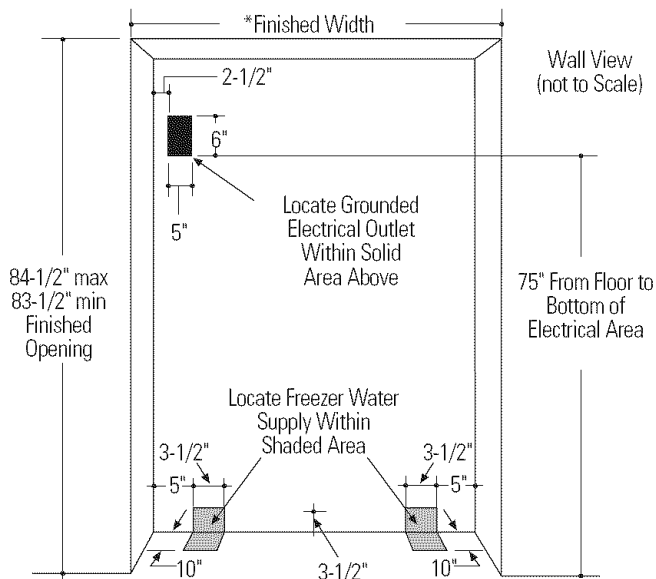

- * 36" Min. for a flush installation into an enclosure.
- * 35-1/2" Min. for a semi-flush installation into an enclosure.

NOTE: Additional cutout width may be required when side panels are used. Add side panel thickness to the finished cutout width to calculate rough-in width. See installation examples, pages 4 and 5.

Clearances:

When installed into a corner:

Allow 25" for a full 130° door swing. Allow 15" for pan removal. Allow 4" min. clearance when door swing is adjusted to a 90° opening for pan access, but pan removal is restricted. Order WX14X99 adjustable door stop to reduce door swing to as little as 90°.

Custom Door Panel Dimensions Using Standard Trim
1/4" thick panels
 or
Panels secured to 1/4" thick backing

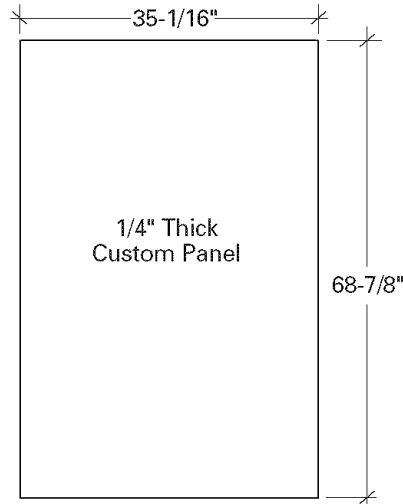

ZIR36N Refrigerator
ZIF36N Freezer

- 1/4" Panel: Cut panels to size.
- Custom handle with 1/4" door panel requires Trim kits ZKHR1 or ZKHRSS1 for tubular stainless steel handles.

Standard Trim with Panels secured to 1/4" thick backing

- Applying a raised panel design to a 1/4" thick backing (screws or glued): Cut 1/4" thick panels to size. Fabricate the raised panel to permit at least 2" fingertip clearance of the standard handle. 1-1/4" clearance from the hinge side to avoid striking adjacent cabinetry and 5/16" from the top and bottom edges to allow for the trim flange.

NOTE: ZKHTR1 custom handle kit cannot be used in this configuration.

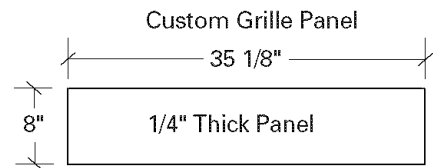

IMPORTANT: Maximum total weight for assembled door panel is 67 lbs., maximum grille panel weight is 9 lbs.

The grille panel frame is factory assembled for 84" installation height. If installation height varies, order ZGC2 trim kit that provides optional side trim pieces. Cut grille panel to sizes shown below.

Installation Height	Panel Height
83-1/2"	7-1/2"
84-1/2"	8-1/2"

Raised Panel on 1/4" Thick Backing Using Standard Handles

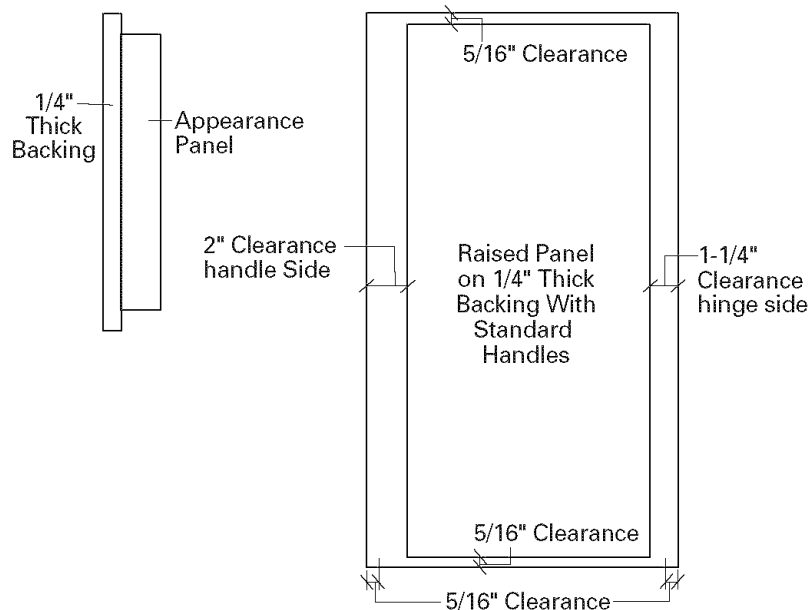

Custom Door Panel Dimensions
Using Trim Kits ZKTR36LH or ZKTR36RH
3/4" thick panel with kit supplied handle

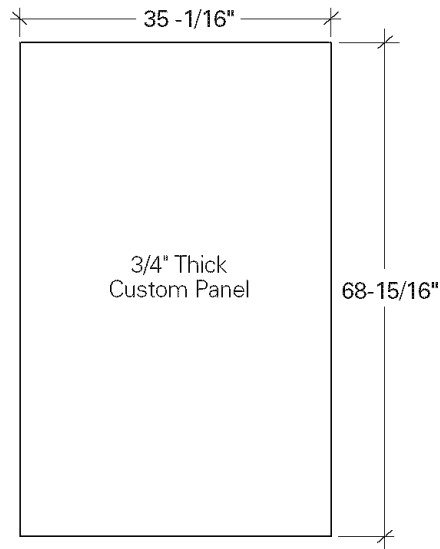

ZIR36N Refrigerator
ZIF36N Freezer

- The ZKTR36LH (or ZKTR36RH) trim kit provides for the installation of 3/4" thick custom door and grille panels, using the supplied handle. Cut panel to size and install.

IMPORTANT: Maximum door panel weight is 67 lbs., maximum grille panel weight is 9 lbs.

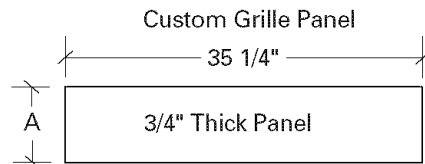

Grille Panel height can vary to fill installation height.

Installation Height	Dimension A
83-1/2"	7-3/4"
84"	8-1/4"
84-1/2"	8-3/4"

IMPORTANT: Maintain 1-1/2" min. gap between top of door and bottom of grille panel.

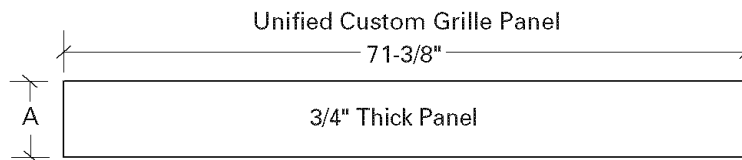

Custom Panel Dimensions

36" Refrigerators, Freezers

Custom Door Panel Dimensions Using Standard Trim Using Trim Kit ZKTR36LH or ZKTR36RH 3/4" thick panel with custom handle

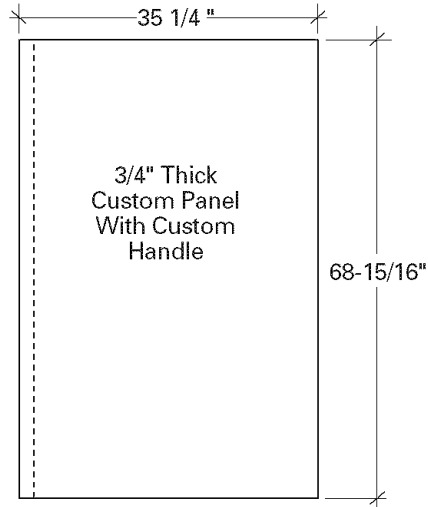

ZIR36N Refrigerator ZIF36N Freezer

•The ZKTR36LH (or ZKTR36RH) trim kit installed together with a ZKHTR1 custom handle kit provides for the installation of 3/4" thick custom door and grille panels with a custom handle of your choice. Order ZKHTRSS1 for a tubular stainless steel handle. Cut panels to size, rout the handle side of the panel as shown below and install.

IMPORTANT: Maximum door panel weight is 67 lbs., maximum grille panel weight is 9 lbs.

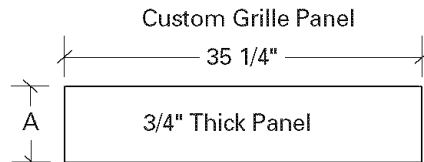
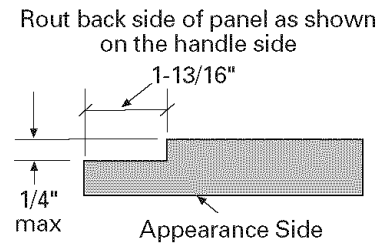

Grille Panel height can vary to fill installation height.

Installation Height	Dimension A
83-1/2"	7-3/4"
84"	8-1/4"
84-1/2"	8-3/4"

IMPORTANT: Maintain 1-1/2" min. gap between top of door and bottom of grille panel.

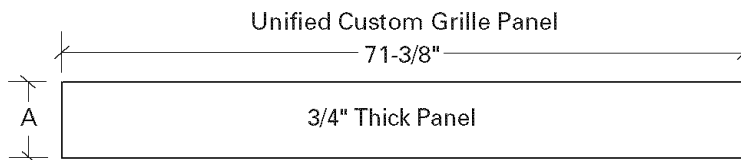

Side Panel or Filler Options
(Not to scale)

Side panels must be used whenever the sides of the refrigerator or freezer will be exposed.

1/4" Side Panels

Insert end of side panel into trim. Use stick-on hook and loop fastener strips to secure the panel to the refrigerator.

Top View

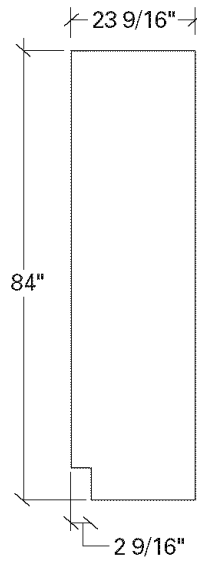
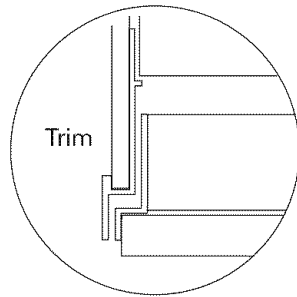

Standard 4" high toe-kick or trim to fit. Height may vary depending on application.

1/2" to 3/4" Side Panels
Leading Edge
Flush with Cabinet Front. The front or leading edge must be finished to match cabinetry.

Top View

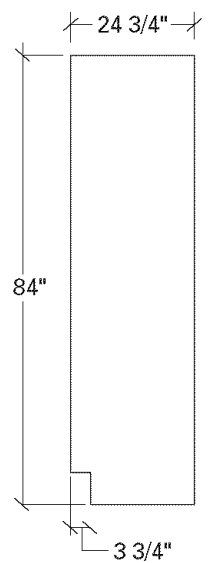
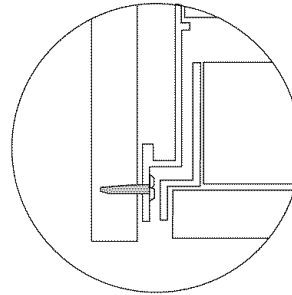

Standard 4" high toe-kick or trim to fit. Height may vary depending on application.

1/2" to 3/4" Side Panels
Recessed front edge.

Top View

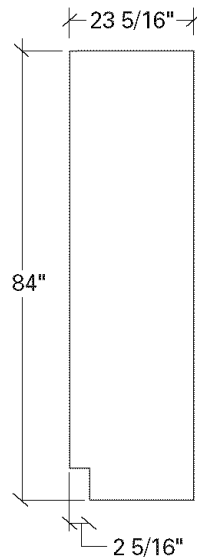
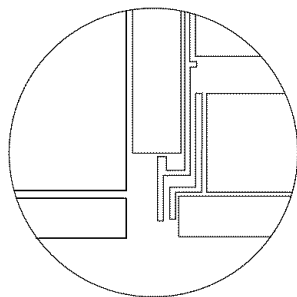

Standard 4" high toe-kick or trim to fit. Height may vary depending on application.

Installation

36" Refrigerators, Freezers

Tools Required

- Tinsnips to cut banding
- Step ladder
- 1-1/4" open-end wrench
- Bucket
- Level
- Appliance Hand Truck
- Tubing cutter
- 7/16" open-end wrench
- #2 Phillips screwdriver
- Stubby Phillips screwdriver
- Drill and appropriate bits
- 7/16" socket with 3" extension for ratchet
- Safety glasses

Materials Required

- Water shut-off valve
- Water filter WR97X0214 (optional but recommended)
- Custom panel for door and grille panel
- 1/4" Copper water line tubing or GE SmartConnect™ Tubing Kit
- Stick-on hook and loop fastener strips for 1/4" side panels
- 35" long 2x4 for Anti-Tip support
- Screws to secure refrigerator to cabinetry

Hardware Supplied

- 1/4-1/4 union with nuts
- Anti-Tip Mounting Brackets

Flooring

For proper installation, the refrigerator or freezer must be placed on a level surface of hard material the same height as the rest of the flooring. The floor should be strong enough to support a fully loaded refrigerator or freezer, or approximately 1,200 lbs.

NOTE: Protect the finish of the flooring. Cut a large section of the cardboard carton and place under the product where you are working.

Grounding the Refrigerator

IMPORTANT – (Please read carefully)

FOR PERSONAL SAFETY, THIS APPLIANCE MUST BE PROPERLY GROUNDED.

The power cord of these appliances is equipped with a three-prong (grounding) plug which mates with a standard three-prong (grounding) wall receptacle to minimize the possibility of electric shock hazard from this appliance.

Have the wall outlet and circuit checked by a qualified electrician to make sure the outlet is properly grounded.

Where a standard 2-prong wall outlet is encountered, it is your personal responsibility and obligation to have it replaced with a properly grounded 3-prong wall outlet.

IMPORTANT:

We recommend two separate 115V, 60Hz, 20 amp., properly grounded electrical outlets for a side by side installation of two products. Each electrical outlet should have a voltage rating that matches the rating plate.

DO NOT, UNDER ANY CIRCUMSTANCES, CUT OR REMOVE THE THIRD (GROUND) PRONG FROM THE POWER CORD.

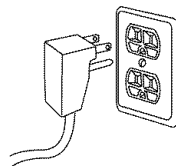

Use of Adapter plug

Because of potential hazards under certain conditions, we strongly recommend against use of an adapter plug. However, if you still elect to use an adapter, where local codes permit, a TEMPORARY CONNECTION, may be made to a properly grounded 2-prong wall outlet by use of a UL listed adapter available at most hardware stores.

The larger slot in the adapter must be aligned with the larger slot in the wall outlet to provide proper polarity in the connection of the power cord.

CAUTION

Attaching the adapter ground terminal to a wall outlet cover screw does not ground the appliance unless the cover screw is metal, and not insulated, and the wall outlet is grounded through the house wiring. You should have the circuit checked by a qualified electrician to make sure the outlet is properly grounded.

PRUDENCE

FICHE D'ADAPTATION
(Fiches d'adaptation non permises au Canada)

When disconnecting the power cord from the adapter, always hold the adapter in place with one hand and pull the power cord with the other hand. If this is not done, the adapter ground terminal is very likely to break with repeated use.

Should the adapter ground terminal break, DO NOT USE the appliance until a proper ground has again been established.

Use of Extension Cords

Because of potential safety hazards under certain conditions, we strongly recommend against the use of an extension cord. However, if you still elect to use an extension cord, it is absolutely necessary that it be a UL listed 3-wire grounding type appliance extension cord having a grounding type plug and outlet and that the electrical rating of the cord be 15 amperes (minimum) and 120 volts.

Step 1
Remove
Packaging

! CAUTION

Refrigerator and freezer is much heavier at the top than at the bottom - be careful when moving. When using a hand truck, handle from side only.

! PRUDENCE

Le réfrigérateur est beaucoup plus lourd en haut qu'en bas. Il faut être prudent lors des déplacements. Si un diable est utilisé, il faut soulever le réfrigérateur sur le côté seulement.

- Remove outer carton.
- Carefully cut banding at the top and bottom.
- Slide out back corner posts (2).
- Slide carton off top of cabinet.

NOTE: IT IS NOT NECESSARY TO LAY CABINET DOWN IN ORDER TO REMOVE SKID!

- The unit is secured to the skid with 4 slotted tie-down straps. First remove the 5/16" bolts from the base channels in the tie-downs, then remove the 7/16" bolts securing the straps to the skid.
- Protect the flooring. Cut a large piece of the cardboard carton and place under the product.
- Support blocks on the bottom must be removed before the refrigerator is taken off the skid or damage will occur. Remove support blocks by carefully tilting cabinet to side and sliding out.

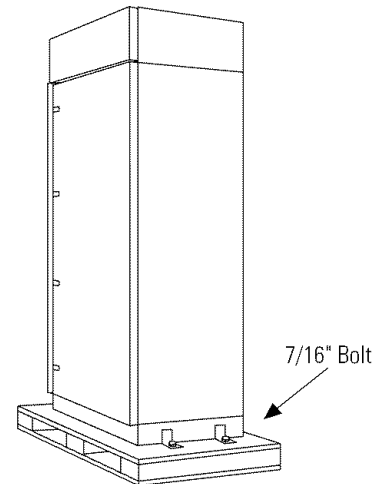

- Lift the refrigerator off the skid with an appliance dolly. Handle from the sides.

! CAUTION

DO NOT ATTEMPT TO ROLL UNIT OFF SKID.

! PRUDENCE

IL NE FAUT PAS ESSAYER DE FAIRE ROULER LE RÉFRIGÉRATEUR POUR L'ENLEVER DE LA PALETTE.

Step 2 Install Water Line

- A cold water supply is required for automatic icemaker operation. The water pressure must be between 20 and 120 p.s.i.
- Route 1/4" OD copper or GE SmartConnect™ tubing between house cold water line and the water connection location.
- Tubing should be long enough to extend to the front of the refrigerator. Allow enough to accommodate bend leading into the water valve.

NOTE: The only GE approved plastic tubing is supplied in the GE SmartConnect™ Refrigerator Tubing kits. Do not use any other plastic water supply line because the line is under pressure at all times. Other types of plastic may crack or rupture with age and cause water damage to your home.

GE SmartConnect™ Refrigerator Tubing Kits are available in the following lengths:
 2' (.6 m) WX08X10002
 6' (1.8 m) WX08X10006
 15' (4.6 m) WX08X10015
 25' (7.6 m) WX08X10025

Shut off the main water supply.

Turn on the nearest faucet long enough to clear the line of water.

- Install a shut-off valve between the icemaker water valve and cold water pipe in a basement or cabinet. The shut-off valve should be located where it will be easily accessible.
- Turn on the main water supply and flush debris from the line. Run about a quart of water through the tubing into a bucket. Shut off water at the shut-off valve.

NOTE: Saddle type shut-off valves are included in many water supply kits, but are not recommended for this application.

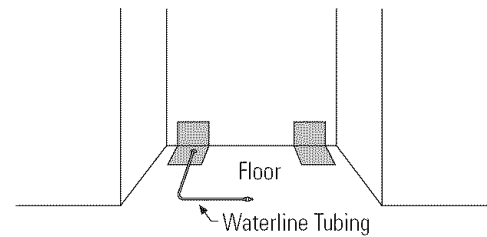

- Install optional water filter in the water line near the refrigerator. A water filter is recommended in areas where water supply contains sand or particles. Installation instructions are packed with the filter.

NOTE: Commonwealth of Massachusetts Plumbing Codes 248CMR shall be adhered to. Saddle valves are illegal and use is not permitted in Massachusetts. Consult with your licensed plumber.

Installation

36" Refrigerators, Freezers

Step 3 Install Side Panels

- Side panels are not required when the refrigerator or freezer is installed into an enclosure. Skip this step if you are installing into an enclosure.
- Side panels are required whenever the sides of the refrigerator or freezer will be exposed and when installed between frameless cabinets. See pages 3 and 4.
- Side panel installation will be determined by the design of the side panel you have previously chosen.
- Side panels must be installed plumb.

Illustration A

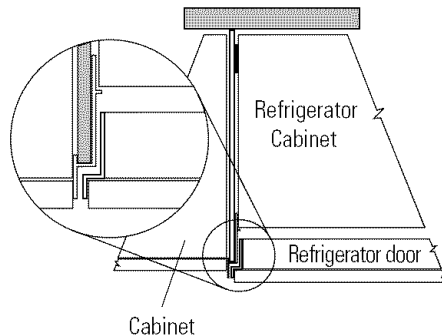

1/4" Side panels – Insert end of side panel into case trim. Fasten with stick-on hook and loop strips.

- If you choose to use 1/4" side panels, they should be inserted into the case trim as illustrated. Fasten the panels to the refrigerator with stick-on hook and loop fastener strips before setting refrigerator in place. See illustration A.
- 1/2" to 3/4" side panels are normally set into place and fastened to adjacent cabinetry or the back wall before rolling the refrigerator into the opening. See illustration B.

Illustration B

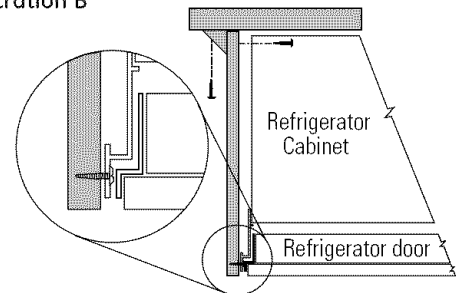

1/2" to 3/4" Side Panels – Leading edge of side panel is flush with cabinet front. Fasten to the back wall using a cleat.

Step 4 Install Anti-Tip Brackets

! WARNING

ANTI-TIP PRECAUTIONS
The refrigerator is top-heavy and must be secured to prevent the possibility of tipping forward.

! ATTENTION

PRECAUTIONS CONTRE LES BASCULEMENTS
Le réfrigérateur est beaucoup plus lourd en haut et il faut le maintenir en place pour éviter la possibilité de son basculement vers l'avant.

- Cut a 2" x 4" x 35" block and secure the block to the mounting brackets provided using #12 or #14 wood screws.
- Secure the bracket with wood block to the back wall so that it is 84" (or your installation height) from the finished floor. Use #12 or #14 wood screws. See illustration.
- Screws must penetrate at least one inch into vertical wall studs.
- Before pushing the refrigerator into the opening, plug the power cord into the receptacle. Open the grille panel and reach into the opening at the back to grasp the power cord. Pull the power cord into the opening as you push the refrigerator back.
- Gently push refrigerator into the opening with hands against front corners.

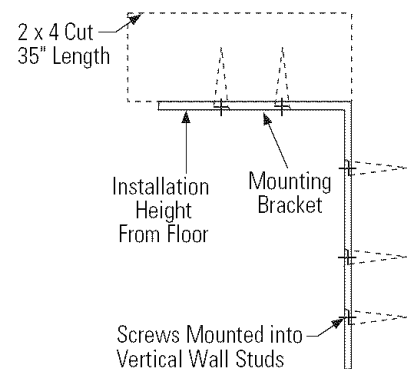
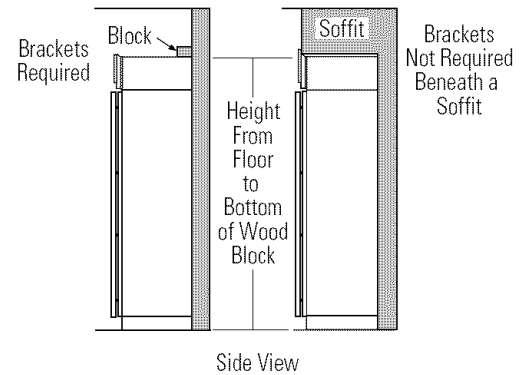

IMPORTANT NOTE: When the refrigerator is installed under a soffit or if there is not enough height for this method of security, brackets cannot be used. Proceed to step 5 to level the refrigerator and then to step 6 to secure refrigerator to cabinets. The refrigerator must be secured to prevent tipping.

Installation

36" Refrigerators, Freezers

Step 5 Level Refrigerator or Freezer

All models have 4-point leveling. The front is supported by leveling legs, the rear is supported by wheels.

- Adjust rear wheels beneath the product to just barely touch the 2x4 block.
- Turn the 7/16" hex nut located above the front wheels. Turn to raise or lower the refrigerator.
- For front leveling legs, use a 1-1/4" open-end wrench.
- Adjust carefully, the refrigerator should be level and plumb with cabinetry, and align with toekick height.

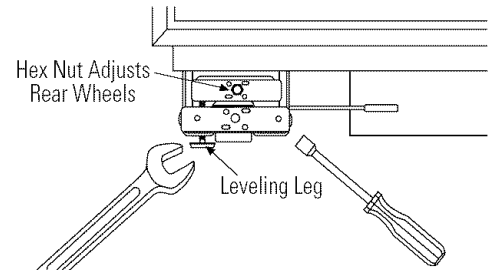

⚠ CAUTION

The rear leveling wheels and front leveling legs are limited to a maximum height adjustment of 1". If the installation requires more than 84-1/2" height, the installer should elevate the refrigerator on a sheet of plywood or runners. Cabinetry trim could also be added across the top of the opening to shorten the opening. **If you attempt to raise the refrigerator more than 1", you will damage the front leveling legs and the rear leveling wheels.**

⚠ PRUDENCE

Les roues de nivellement arrière et les pattes de nivellement avant permettent un réglage maximal de 25 mm (1 po). Si l'ouverture pour le réfrigérateur a une hauteur supérieure à 2,15 m (84-1/2 po), l'installateur doit élever le réfrigérateur sur une feuille de contre-plaqué ou des glissières. Il est également possible d'ajouter des baguettes de finition des placards sur le haut de l'ouverture afin de la réduire. Lever le réfrigérateur de plus de 25 mm (1 po) endommage les pattes de nivellement avant et les roues de nivellement arrière.

Step 6 Secure Refrigerator or Freezer to Sides

NOTE: Whenever possible, perform this step for additional anti-tip security. This step can be used as an alternate to Step 4, Anti-Tip bracket installation, whenever brackets cannot be used.

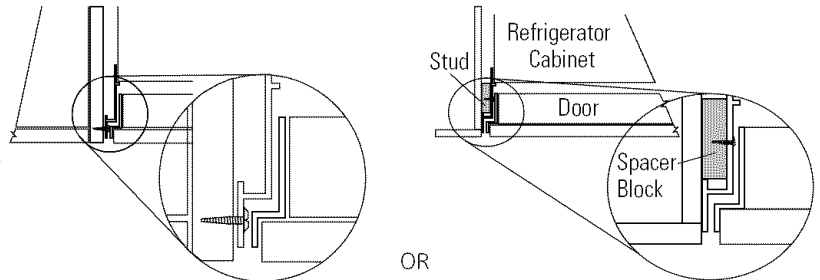

When using 1/2" to 3/4" side panels, the front flange of the case trim is attached to the side panel.

- Open door to access case trim.
- Drill hole in trim slightly below the interior opening. Drive screw through the trim and into the side panel.

- Follow the same procedure on the opposite side.
- If the product is installed between cabinets with no side panels or in a custom enclosure, install a spacer block as shown.

Step 7 Connect Freezer Water Supply

- Locate and bring tubing to the front of the cabinet.
- Turn the water on to flush debris from line. Run about a quart of water through tubing into a bucket, then shut-off water.

Copper Tubing:

- Slip a 1/4" nut and ferrule (provided) over both ends of the copper tubing. Insert tube into the union fitting on the unit and tighten nut to union.
- Turn on the water to check for leaks.

GE SmartConnect™ Tubing:

- Insert the molded end of the tubing into the refrigerator connection. Tighten the compression nut until it is just hand tight.
- Tighten one additional turn with a wrench. Overtightening can cause leaks!
- Turn on the water to check for leaks.

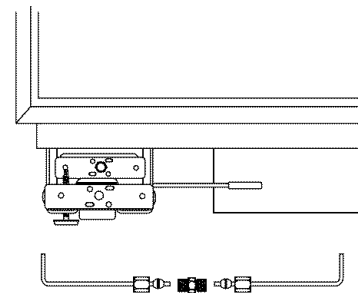

NOTE: Make sure excess tubing length does not interfere with toekick installation.

Installation

36" Refrigerators, Freezers

Step 8 Install 1/4" door panels

If you are using a 3/4" thick custom panel, SKIP THIS STEP. See Custom Panel Dimensions pages for panel sizes with ZKTR36LH or ZKTR36RH trim kit and other kits. Refer to trim kit instructions in this booklet.

- Open door to 90° stop. Remove the Phillips head screws from the aluminum trim door handle.
- Remove handle. Retain all screws and handle.
- Slide custom panel into the door trim.
- Replace door handle and secure with original screws.

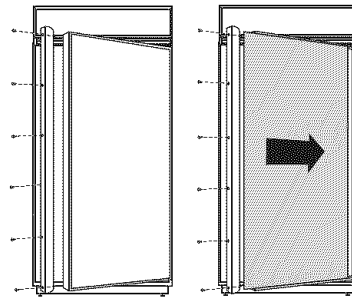

Step 9 Check Power

- Check to make sure power is on by opening the door to see if interior lights are on.

Step 10 Mount Top Grille Panel

If you are using a 3/4" thick custom panel, SKIP THIS STEP. See Dimensions and Specifications for grille panel sizes. Order ZKTR36LH or ZKTR36RH and follow the installation instructions packed with the kit.

The grille panel frame is factory assembled for an 84" installation height. If installation height varies, order ZGC2 trim kit which provides optional side trim pieces for 83-1/2" and 84-1/2" heights.

Cut 1/4" thick custom panel to fit the frame, 35-1/8" wide, 8" deep (for an 84" installation).

To insert custom grille panel into the frame:

- Remove screws (2 on each top corner) and "L" brackets on each side.
- Slide panel into the frame and reassemble.
- Mount the grille panel by dropping into slots on the case trim.

- For shipping purposes, the top case trim is secured at 84" installation height.

To raise case trim to 84-1/2" or to lower to 83-1/2" installation height:

- Loosen 2 screws on both sides and raise the top or lower case trim to meet soffit height or to the top of adjacent cabinets.
- Tighten all 4 screws.

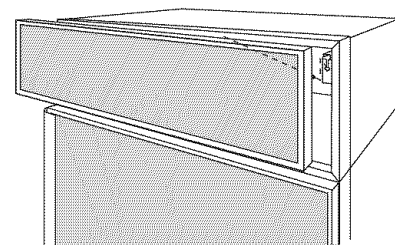
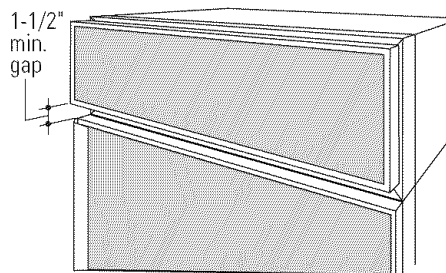
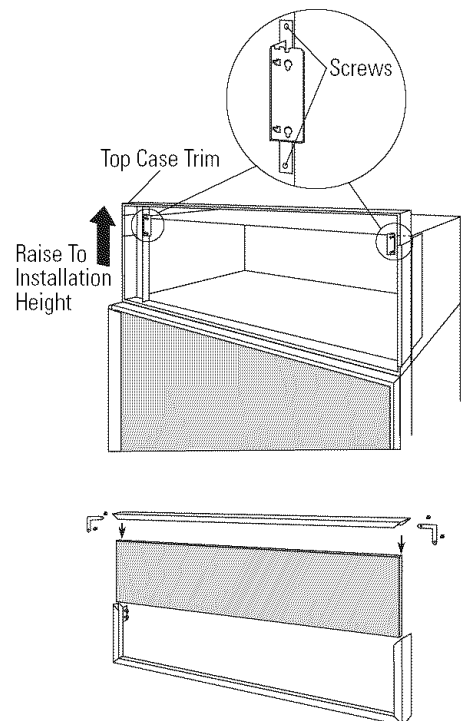

IMPORTANT: Maintain 1-1/2" min. gap between top of doors and bottom of panel frame.

Installation

36" Refrigerators, Freezers

Step 11 Adjust Door Alignment

Check door alignment. The top of the door should be parallel with the grille panel. If the door appears to be too high or too low on the handle side, adjustments can be made by turning the hinge.

- To raise the door, turn adjustable hinge pin towards the right.
- To lower the door, turn hinge pin towards the left.

Turn the hinge pin with a 5/16" wrench or, on some models, use the 3/16" Allen wrench taped to the hinge.

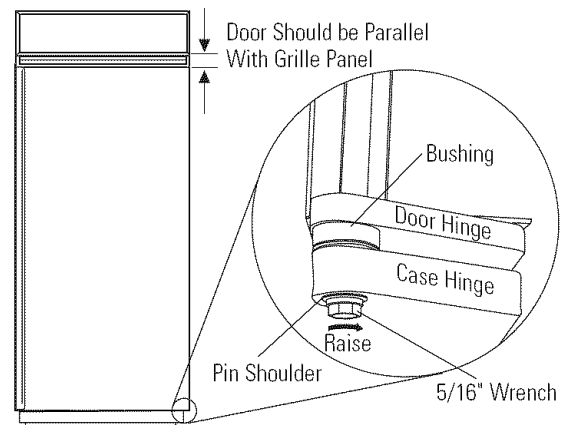

Step 12 Arrange Interior and Set Temperature Controls

- Remove internal packing materials.
- Remove tape from all shelves.
- Set control at "5".

IMPORTANT: Allow 24 hours for temperatures to stabilize before making adjustments.

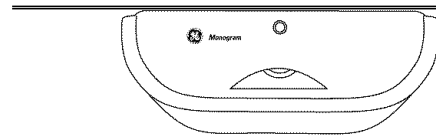

Step 13 Start Icemaker

- Start the switch to I (on). The green light will come on and the icemaker will begin operation automatically.
- Be sure nothing interferes with the sweep of the feeler arm.
- Discard the first few batches of ice cubes.
- To turn the icemaker off, set the switch to O (off). Allow 45 minutes for the icemaker to resume operation.

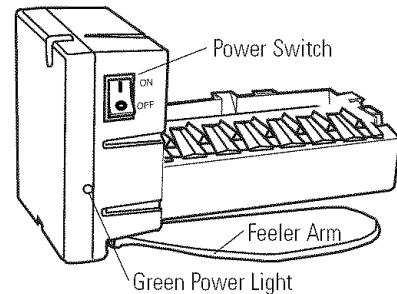

Step 14 Install Toekick

- A standard toekick is supplied. Install with 2 screws provided, adjust to desired height and tighten screws.

IMPORTANT: The vented toekick must remain unobstructed for proper air circulation and operation.

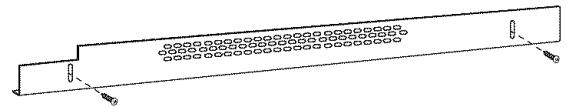

This kit provides optional side trim pieces for the original grille panel frame to fit 83-1/2" and 84-1/2" installation heights.

To change grille panel size:

- Determine the installation height by measuring the enclosure from the floor to the underside of soffit. When there is no soffit, measure to the top of the adjacent cabinets.
- Adjust refrigerator case trim to desired height. See Product Installation.
- Select the side trim pieces for your installation height.

- Locate original grille panel frame supplied with the refrigerator.
 - Remove 8 screws (two on each corner) and "L" brackets as illustrated.
- Select correct set of side trim pieces (2 sets provided).
 - Secure new side trim pieces to original bottom trim.

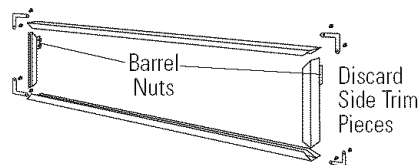

- Remove barrel nuts from original side trim pieces (2 each side).
 - Reinstall the barrel nuts on the new side trim pieces you have selected. Discard original side trim.

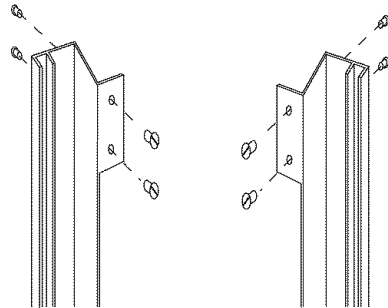

- Slide custom panel into front slots.
 - Secure the top trim piece to the frame with "L" brackets and screws.

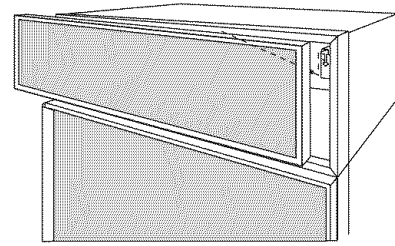
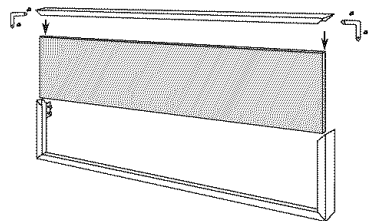

- Mount the assembled panel by dropping into slots on the case trim.

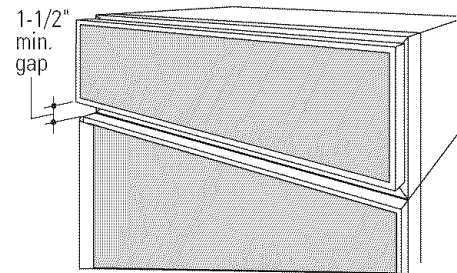

IMPORTANT: Maintain 1-1/2" min. gap between top of door and bottom of grille panel.

ZKHR1 Trim Kit (For 1/4" Panels)

Support for Custom Handles

Tools and materials required:

- #2 Phillips screwdriver
- Drill and appropriate bits
- Custom door panel
- Custom Handle
- Safety glasses

Right hand door swing models are illustrated in these instructions. Follow these instructions for left hand models.

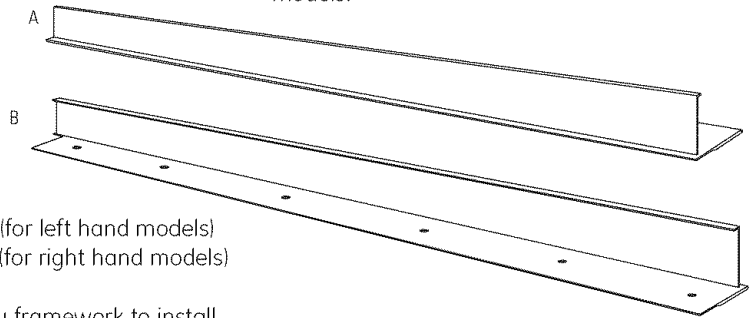

Parts List:

- A. Handle side door extrusion (for left hand models)
- B. Handle side door extrusion (for right hand models)

This kit provides the necessary framework to install a custom handle, of your choice, onto a 1/4" thick custom panel. (Handles not included.) The extrusions in this kit allow the custom handle to be secured to the door structure, rather than the door panel.

- Select the extrusion for your model, discard other extrusion.

Step 1
Remove
handle

- Open door to 90°. Remove the screws from the full length aluminum handle.
- Retain screws. Discard handle.

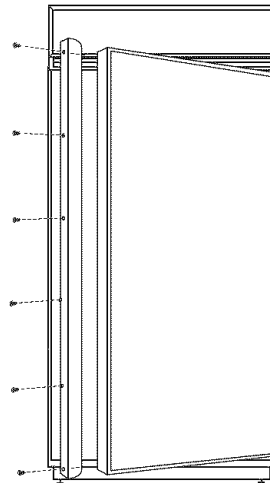

ZKHR1 Trim Kit (For 1/4" Panels)

Support for Custom Handles

Step 2 Locate handle position

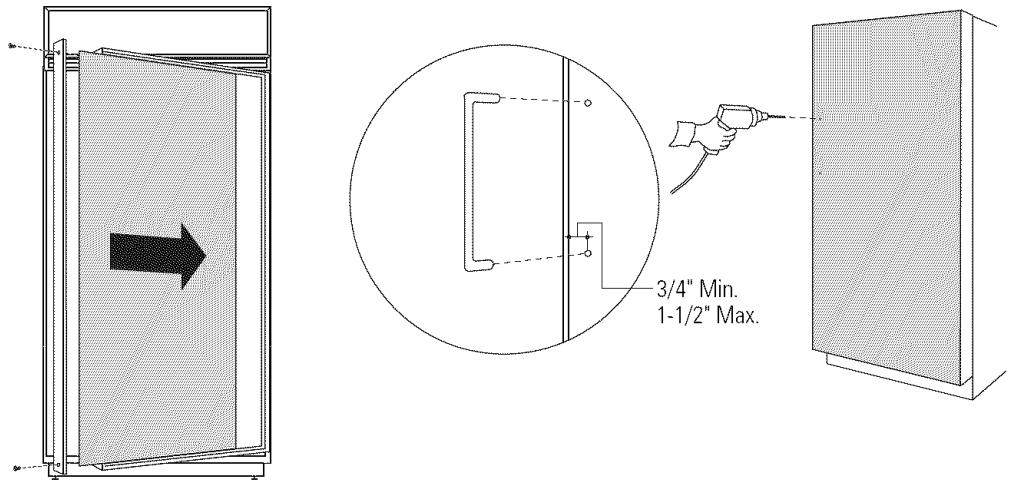

- Slide custom panel into the door trim.
- Temporarily secure the new handle extrusion to the door using at least 2 screws.
- The custom handles must be located 3/4" to 1-1/2" from the edge of the extrusion.
- Determine the desired location of the custom handle and mark centerlines of the screw holes.
- Drill 1/16" pilot hole through the panel until it starts into the aluminum extrusion. This will mark the matching location for drilling the clearance hole when assembling the handle, panel and extrusion.

Step 3 Assemble panel, extrusion and handle

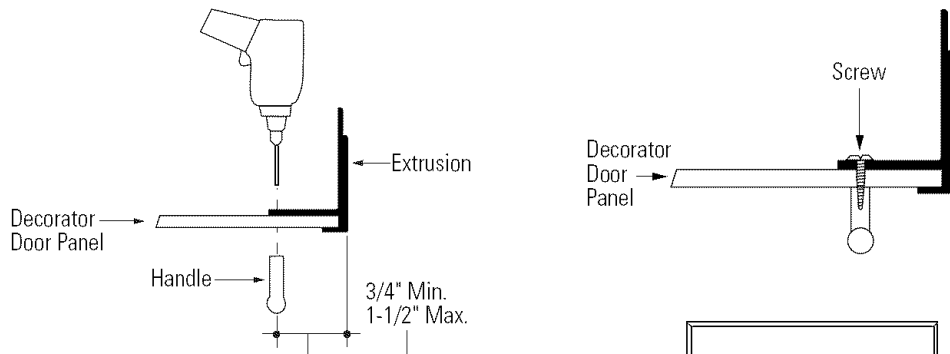

- Remove the handle extrusion and custom panel.
- Drill 1/16" pilot hole through extrusion.
- Drill clearance holes through the panel and extrusion.
- Assemble the door panel, extrusion and custom handle.
- Install screw(s) long enough to pass through the extrusion, door panel and into the handle.
- Slide the assembly into the door frame until the new extrusion fits firmly against the steel door.
- Reinstall original screws into the door extrusion.

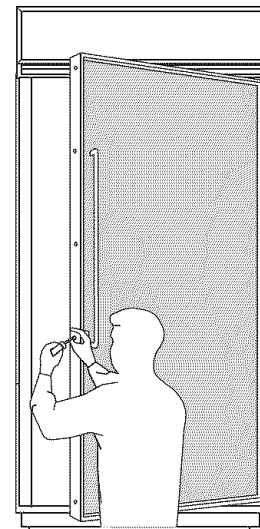

Kit Contents

Right hand door swing models are illustrated in these instructions. Follow these instructions for left hand models.

This kit provides for the installation of 3/4" thick custom door and grille panels. Handles are included and must replace the supplied handles.

Tools and materials required:

- #2 Phillips screwdriver
- Drill and appropriate bits
- Custom door panels
- Putty knife
- Safety glasses
- 7/16" wrench

Parts List

- A. Top trim
- B. Handle side trim
- C. Hinge side trim
- D. Bottom trim
- E. Support bracket for custom panel
- F. 4-3/8" screws for support brackets (20)
- G. Grille support panel and screws (6)
- H. Wood screws #6 1/2" flat head screws (30)

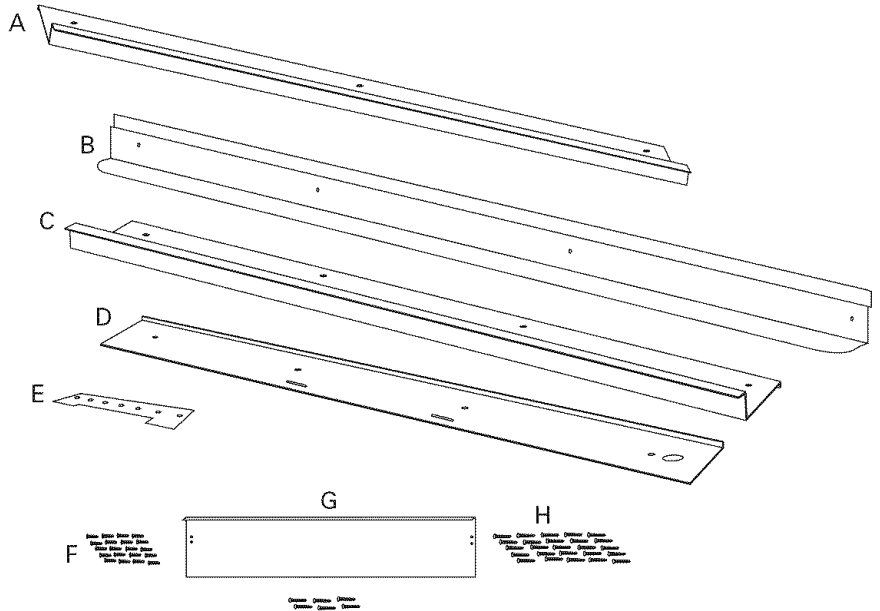

NOTE: If you are using a custom handle, see ZKHTR1 installation instructions. For a tubular stainless steel handle, see ZKHTRSS1 installation instructions.

Step 1 Remove handles and trim

- Open door to 90°.
 - Remove the Phillips head screws from the full length handle, remove and discard handle. Retain screws.
 - Open the door fully to stop.
- NOTE:** Removal of actuator arm allows the door to be opened wider, giving greater access to hinge side trim.
- Remove the screws from the aluminum trim, top bottom and hinge side.
 - Retain screws. Discard original trim and handle.

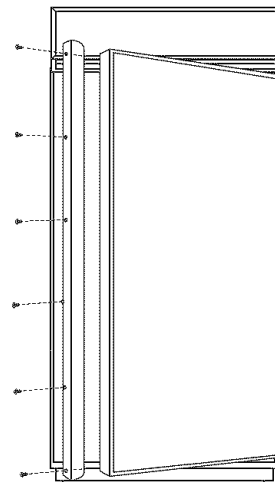

ZKTR36LH/ZKTR36RH Trim Kit

3/4" Custom Panels

Step 2 Install 3/4" trim

- Attach the new 3/4" trim pieces on the top, hinge side and bottom using original screws.

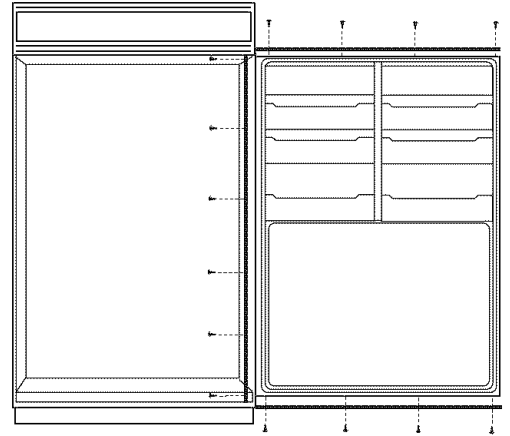

Step 3 Apply panel support brackets

- Position support bracket on the back side of the custom panel, 14-5/16" from the hinge side. Secure support bracket to panel with screws provided.

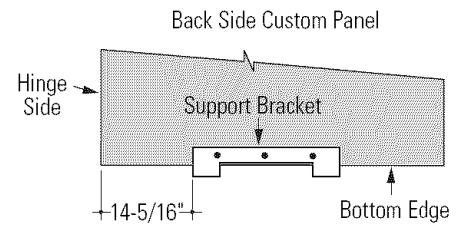

Step 4 Install panels

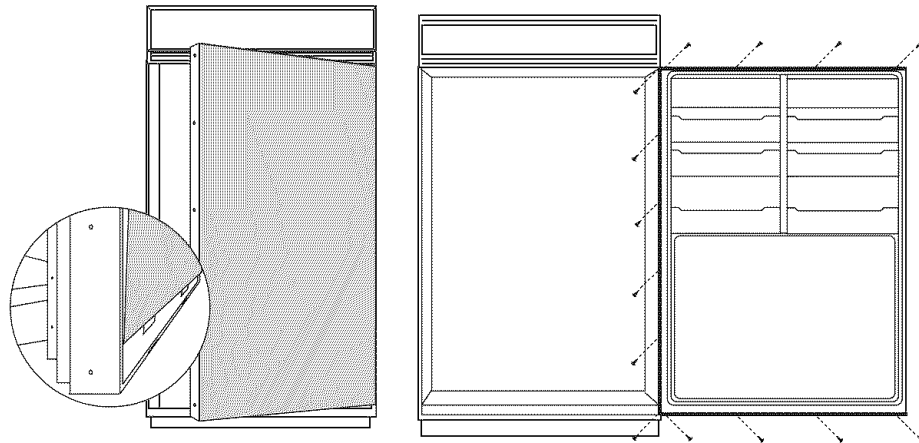

- Place the 3/4" thick panel on the bottom trim with support bracket tabs inserted into slots. Push the panel back against the steel door, flush with hinge side trim.
- Open the door fully.
- Carefully drill 4 starter holes using a small drill bit, through the backside of the trim at the top.
- Install original screws through the trim and into the panel to secure the panel to the door.
- Drill 6 starter holes through the hinge side and 4 through the bottom trim. Install original screws.

ZKTR36LH/ZKTR36RH Trim Kit

3/4" Custom Panels

Step 5 Install handles

- Install new door handle using original screws.

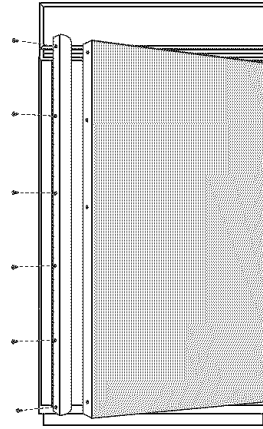

Step 6 Adjust grille panel height

- For shipping purposes, the top case trim is secured at the 84" installation height.
- Loosen 2 screws on both sides of the case trim and raise or lower trim to meet soffit height, from 83-1/2" to 84-1/2".
- Tighten all 4 screws.

IMPORTANT: Maintain 1-1/2" min. gap between top of door and bottom of grille panel.

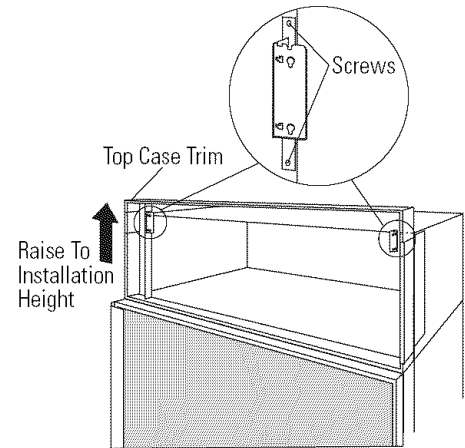

Step 7 Secure 3/4" panel to grille panel support

- Secure the grille panel support to the back side of the 3/4" custom panel with #6 screws.
- Be sure the lip of the support is over the top of the wood panel.

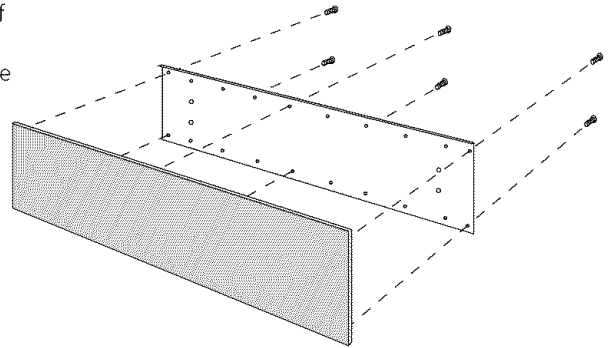
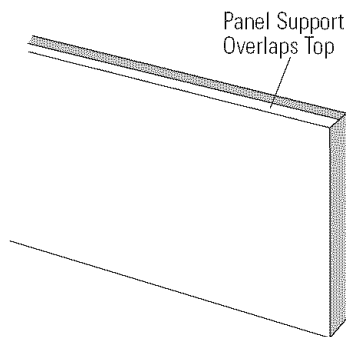

ZKTR36LH/ZKTR36RH Trim Kit

3/4" Custom Panels

Step 8 Install grille panel

- Install four of the six larger undercut screws so that the top of the screws are 1/16" from the surface of the support.
- Attach the assembled panel to the grille opening by inserting the four protruding screws into the brackets on each side.

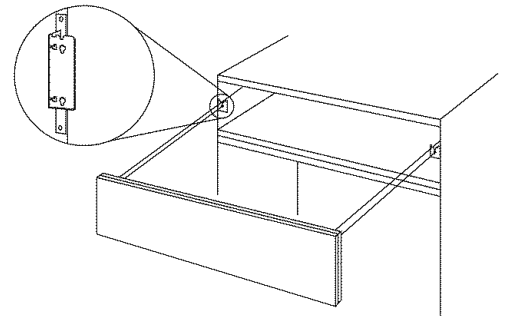
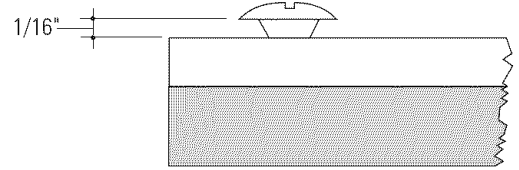
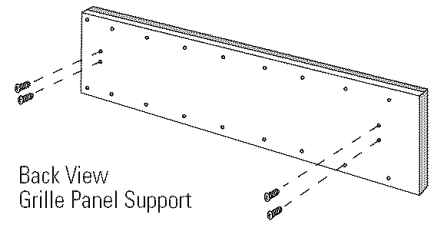

ZKHTR1 Trim Kit (For 3/4" Panels)

Support for Custom Handles

Kit Contents

Right hand door swing models are illustrated in these instructions. Follow these instructions for left hand models.

Tools and materials required:

- #2 Phillips screwdriver
- Drill and appropriate bits
- Custom door panel
- Custom handle
- Safety glasses

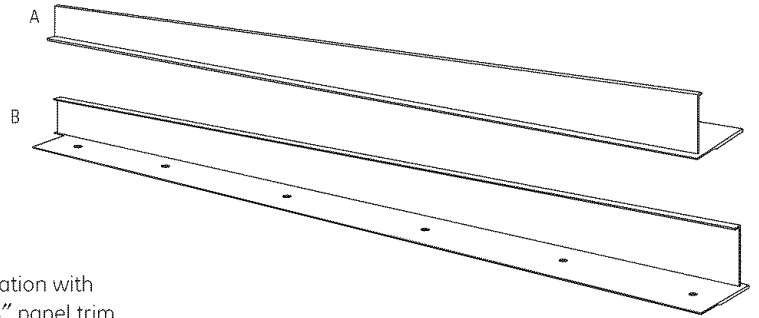

NOTE: This kit must be used in combination with ZKTR36LH or ZKTR36RH trim kit for 3/4" panel trim.

Part List:

- A. Handle extrusion (for left hand models)
- B. Handle extrusion (for right hand models)

This kit provides the necessary framework to install a custom handle, *of your choice*, onto a 3/4" thick decorator door panel. (Handles not included.) The handle extrusion allows the custom handle to be secured to the door structure, rather than the door panel.

- Select handle extrusion for your model, discard other extrusion.

Before you begin

3/4" custom door panel must be routed to accommodate these door handle extrusions. Rout the panel as illustrated, 1/4" deep, and 1-13/16" wide on the handle side.

Refer to installation instructions for ZKTR36LH or ZKTR36RH trim kit for 3/4" custom panels:

- Follow Step 1 to remove the standard aluminum trim.
- Follow Steps 2 and 3 to attach new 3/4" trim pieces and to install panel support brackets.

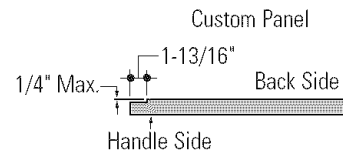

IMPORTANT: Optimal final appearance depends on careful routing depth. Do not exceed 1/4" routing depth.

ZKHTR1 Trim Kit (For 3/4" Panels)

Support for Custom Handles

Step 1 Temporarily mount door panel

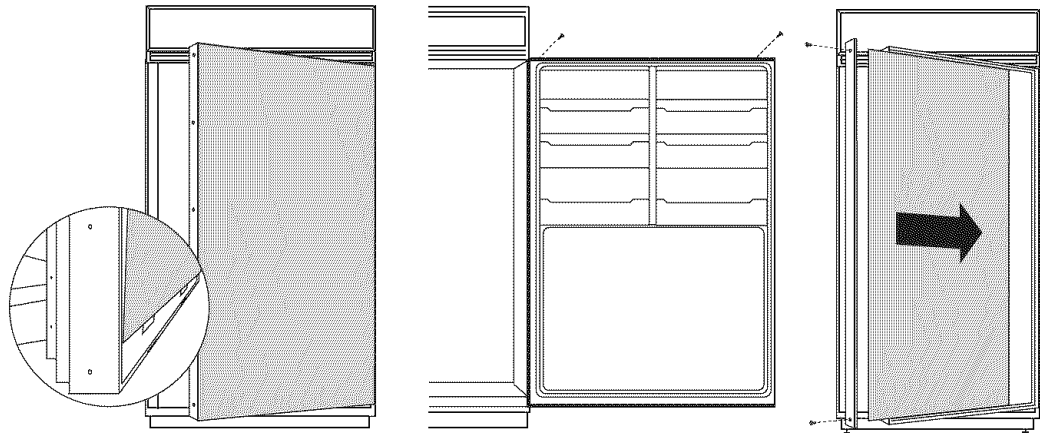

- Place the prepared 3/4" custom door panel on the bottom trim with support bracket tabs inserted into trim slots.
- Push the panel back against the steel door, making sure the panel is flush with the hinge side trim.
- Secure the panel to the trim temporarily by driving 2 screws through the backside of the trim at the top.
- Slide the handle extrusion in between the panel and steel door.
- Temporarily secure the extrusion to the door with 2 screws.

Step 2 Locate position of handle

- Determine the location of the custom handles and carefully mark centerlines of the screw holes. The handles must be located 3/4" to 1-1/2" from the edge of the extrusion.
- Drill 1/16" pilot hole through the panel until it starts into the aluminum extrusion. This will mark the matching location for drilling a clearance hole when assembling the extrusion, panel and handle.

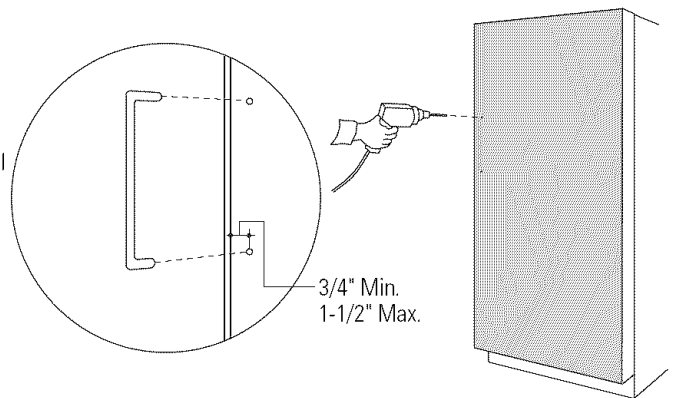

Step 3 Assemble panel, extrusion and handle

- Remove the handle extrusion, the 2 temporary screws and custom panel.
- Drill 1/16" pilot hole through extrusion.
- Drill clearance holes through the panel and extrusion.
- Assemble the panel, extrusion and custom handle.
- Install screw(s) long enough to pass through the extrusion, door panel and into the handle.

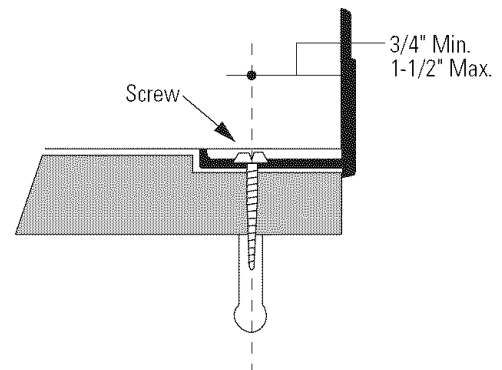

Step 4
Mount
assembled
panel

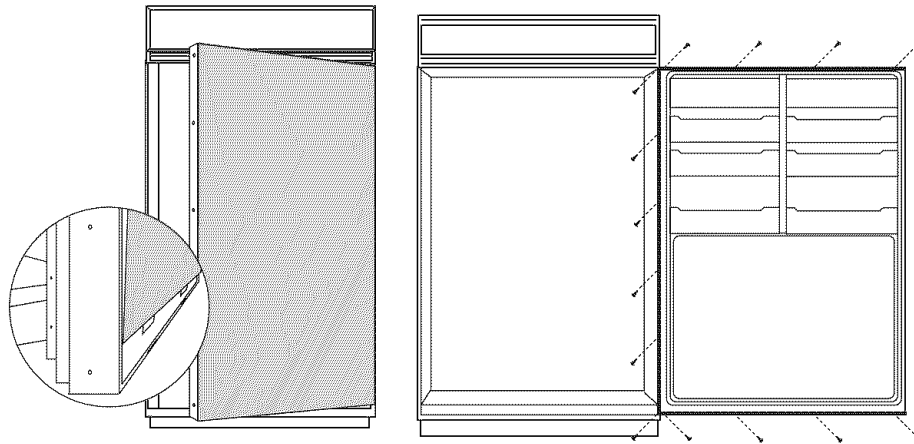

- Place assembled panel onto the bottom trim with support bracket tabs inserted into slots.
- Push the panel back against the steel door with handle extrusion flush to handle side of the door.
- Open door fully to stop.
- Install original screws at the top, hinge side and handle side.

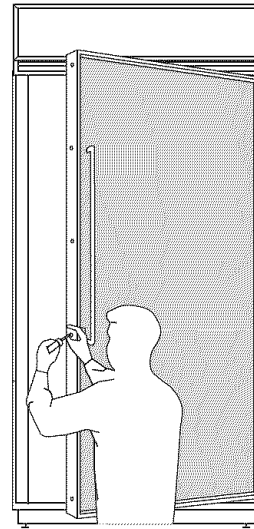

ZKHRSS1 Trim Kit (For 1/4" Panels)

Tubular Stainless Steel Handles

Right hand door swing models are illustrated in these instructions. Follow these instructions for left hand models.

NOTE: It is best that 2 people install this kit.

Tools and materials required:

- #2 Phillips screwdriver
- Drill and appropriate bits
- Custom door panel
- Safety glasses
- Center punch
- Masking tape
- Hammer
- Pencil
- 1/2" thick 12" x 12" min. piece of plywood to protect floor when drilling
- For stainless steel panel, wear gloves to protect against sharp edges.

Parts List:

- A. Handle extrusion (for left hand models)
- B. Handle extrusion (for right hand models)
- C. Door handle
- D. 6 Spacer rings (for Stainless Panels ONLY)
(4 required, 2 extra)
- E. 4 Handle standoffs
- F. 6 Screws for mounting handle standoffs
(4 required, 2 extra)
- G. 6 Set screws (4 required, 2 extra)
- H. 3/32" Allen wrench for set screws

This kit provides for the installation of a Tubular Stainless Steel handle on 1/4" thick decorator door panel. The door extrusions allow the handle to be secured to the door structure, rather than to the custom panel.

- Select extrusion for your model, discard other extrusion.

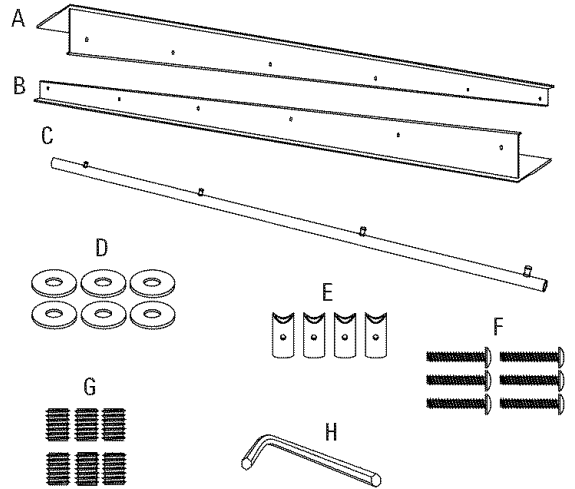

Step 1 Remove handle

- Open fresh food door to 90°. Remove the screws from the full-length handle.
- Retain screws, discard handle.

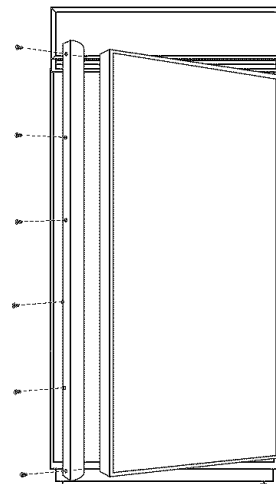

Step 2
Match
handle
extrusions
to handle

**FOR CUSTOM
WOOD
PANELS**

See Step 2A
for Stainless
Steel panels

- Cut a piece of corrugated to use as a pad to protect the panel finish. Use 1/2" thick section of plywood to protect flooring when drilling.
- Place custom panel on the pad, appearance side down.
- On the back side of the panel—at the handle side, measure and mark 1/4" below the top edge of the panel with a pencil.
- Slip panel into new extrusion on the handle side of the panel.
- Align the extrusion at the pencil mark, 1/4" below the top of the panel.
- Tape the extrusion to the panel to prevent movement.
- Center punch and drill 1/8" pilot holes through the holes in the extrusion and into the panel.
- Turn panel over. On the appearance side, use 9/32" bit to enlarge clearance hole.

IMPORTANT: Hole locations must be exact to accept handle standoff and handle assembly.

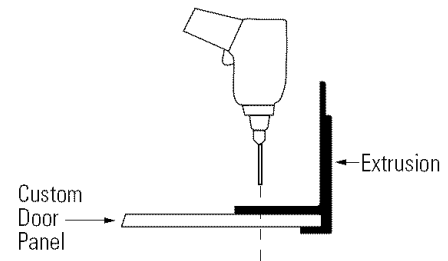
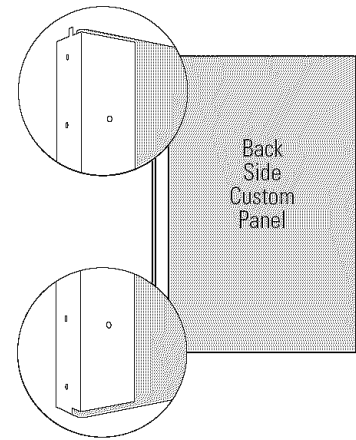

Step 2A

**FOR
STAINLESS
STEEL
PANELS**

If you are installing handle onto a Stainless Steel Panel:

Use extreme caution if you are drilling through a stainless steel panel. Stainless steel panels must be handled gently. Do not kneel on the stainless steel panel. It will leave a permanent dent. Do not remove protective plastic covering until final installation.

- Place supplied filler panel (corrugated) on floor to use as a pad.
- On the back side of the panel—at the handle side, measure and mark 1/4" below the top edge of the panel.
- Slip panel into the new extrusion, flush against inner edge, on the handle side.
- Align extrusion to pencil mark as shown in Step 2. Mark each screw hole location with pencil.
- Tape extrusion to panel to prevent movement.

- Place panel on plywood section, appearance side down. Be sure plywood is clean without nicks and burrs. Center punch at each screw hole location.
- Drill 1/8" pilot hole. Use 9/32" bit to enlarge clearance hole.
- Measure and cut a 2" wide strip, top to bottom off the corrugated panel. This will allow room for spacer rings between the stainless panel and extrusion.

ZKHRSS1 Trim Kit (For 1/4" Panels)

Tubular Stainless Steel Handles

Step 3 Install standoffs onto handles

- Place a handle standoff onto each attachment post along the handle. Position the set screw hole on the standoff to point to the floor.
- Install set screws into the bottom of each standoff, using the Allen wrench provided. The standoff should be tight against the handle.

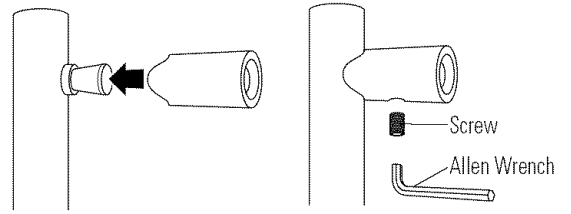

Step 4 Install handles and panels

**FOR CUSTOM
WOOD
PANELS**

See Step 4A
for stainless
steel panels

- Slide panel into the door trim. Leave about 4" of the panel exposed to allow room to install the handle extrusion.
- Place extrusion onto the back side of the panel, install mounting screws through the extrusion and just through the panel.
- Drive screw part way through the top standoff, then part way through the bottom standoff. Install remaining standoffs part way.
- Drive all screws until the handle is tight against the panel.
- Remove tape.
- Slide the assembled panel into the door trim until the extrusion fits firmly against the steel door. Reinstall original screws into the extrusion.

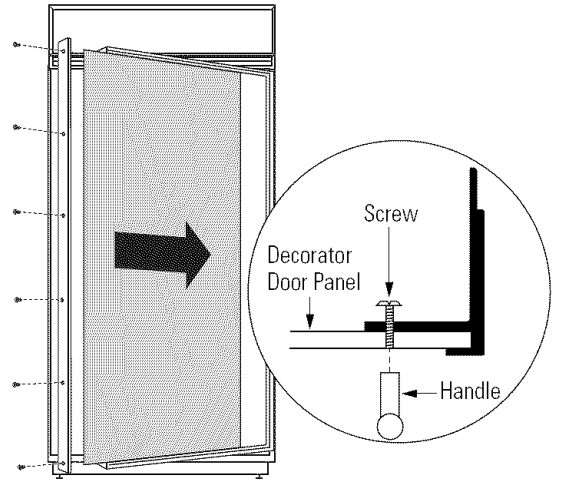

ZKHRSS1 Trim Kit (For 1/4" Panels)

Tubular Stainless Steel Handles

Step 4A
Install
handles
and panels

FOR
STAINLESS
STEEL
PANELS

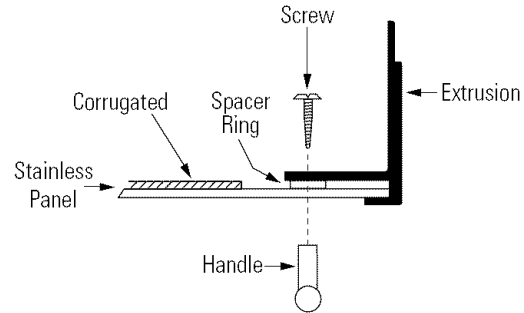
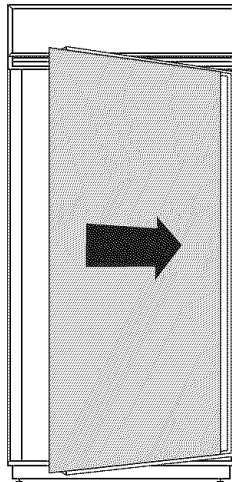

- Crimp top and bottom edges of corrugated.
- Slide corrugated into door trim. Leave about 1/4" gap between edge of corrugated and hinge side trim of the door.

NOTE: Panels have a protective plastic covering. Peel away just enough to allow panel to slide into trim and to clear handle mounting screws. The plastic covering will keep the panel clean during the installation process.

Be sure to maintain 1/4" gap between corrugated and hinge side trim.

- Slide panel into the door trim. Leave about 4" of the panel exposed to allow room to install the handle extrusion.
- Place a spacer ring over each screw hole on the extrusion. Use tape to hold in place.
- Place extrusion onto panel. Use a pencil to punch hole in tape covering spacer rings and align with screw holes.
- Install mounting screws through the extrusion and panel.
- Drive screw part way through the top standoff, then part way through the bottom standoff. Install remaining standoffs part way.
- Drive screws until the handles are tight against the panel.
- Slide the assembly into the door trim until the extrusion fits firmly against the steel door.
- Reinstall original screws into the door extrusion.

Raised Panel on 1/4" Thick Backing:

A raised panel design secured to a 1/4" thick backing (screwed or glued) can be used with this handle kit.

- Cut the 1/4" thick panels to size.
- Fabricate the raised panel to allow 1-1/4" clearance from the hinge side of the panel to avoid striking adjacent cabinetry.
- Allow 5/16" clearance at the other edges to allow for the trim flange.
- Total panel thickness should not exceed 3/4".
- Countertops adjacent to the refrigerator installation should be mitered 45°.

NOTE: Longer Screws, obtained locally, will be required to accommodate panel thickness. Use stainless steel #10-32x1-1/4" truss Phillips head screws.

Raised Panel on 1/4" Thick Backing

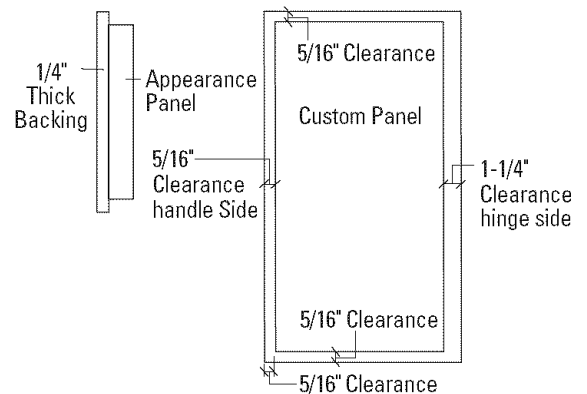

ZKHTRSS1 (For 3/4" Panels)

Tubular Stainless Steel Handles

Kit Contents

Right hand door swing models are illustrated in these instructions. Follow these instructions for left hand models.

This kit must be used in combination with ZKTR36RH or ZKTR36LH trim kit.

This kit provides for the installation of a Tubular Stainless Steel handle on a 3/4" thick decorator door panel. The door extrusions allow the custom handle to be secured to the door structure, rather than to the custom panel.

NOTE: It is best that 2 people install this kit.

- Select the extrusion for your model, discard other extrusion.

Tools and materials required:

- #2 Phillips screwdriver
- Drill and 1/8", 9/32" bits
- Custom door panel
- Safety glasses
- Center punch
- Masking tape
- Hammer
- Pencil

Parts List:

- A. Handle extrusion (for left hand models)
- B. Handle extrusion (for right hand models)
- C. Stainless tubular handle
- D. 4 Handle standoffs
- E. 6 Screws for handle standoffs (4 required, 2 extra)
- F. 6 Set screws (4 required, 2 extra)
- G. 3/32" Allen wrench for set screws

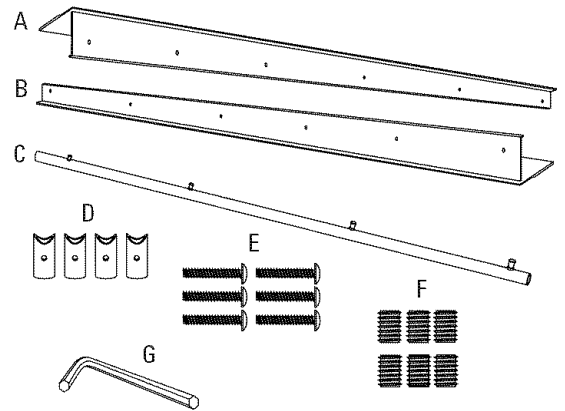

Before you begin:

- The 3/4" custom panel must be routed to accommodate the handle extrusion. Rout the panel as illustrated, 1/4" deep, and 1-13/16" wide, top to bottom on the handle side.
- Follow the instructions in the ZKTR36RH (or ZKTR36LH) to install trim onto the door. Discard the handle supplied with that kit.
- Continue the instructions in the ZKTR36RH (or ZKTR36LH) trim kit to install support brackets to the bottom of the panel.

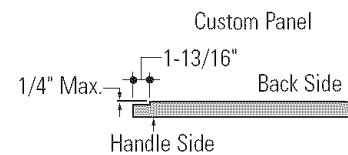

IMPORTANT: Optional final appearance depends on careful routing depth. Do not exceed 1/4" routing depth.

ZKHTRSS1 (For 3/4" Panels)

Tubular Stainless Steel Handles

Step 1 Match Handle Extrusion to Panel

- Cut a piece of corrugated to use as a pad to protect the panel finish. Additional material may be required to protect flooring when drilling.
- Place custom panel on the pad, appearance side down.
- Select handle extrusion for your model, left or right side extrusion.
- Place extrusion against the handle side of the panel.
- Align the extrusion evenly with the top and bottom of the panel.
- Tape the extrusion to the panel to prevent movement.
- Center punch and drill 1/8" pilot holes through the holes in the extrusion and into the panel.
- Turn panel over. On the appearance side, use 9/32" bit to enlarge clearance hole.

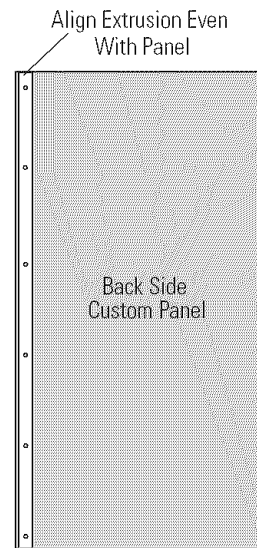

NOTE: Hole locations must be exact to accept handle standoff and handle assembly.

Step 2 Install Standoffs onto Handles

- Place a handle standoff on each attachment post on the handle. Position the screw hole on the standoff to point to the floor.
- Install set screws into the bottom of each standoff, using the Allen wrench provided. The standoff should be tight against the handle.

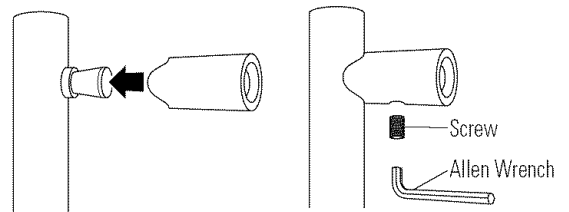

Step 3 Install Mounting Screws and Handles

- Start mounting screws through the extrusion and just through the custom panel.
- Stand panel up on the hinge side and hold to access the appearance side. Place handle against mounting screws on the appearance side, drive top screw from the back of the extrusion partially into the standoff.
- Drive bottom screw partially into the standoff, and then drive remaining screws partially into standoffs. Alternate back to the top, driving screws until the handle is tight against the door.

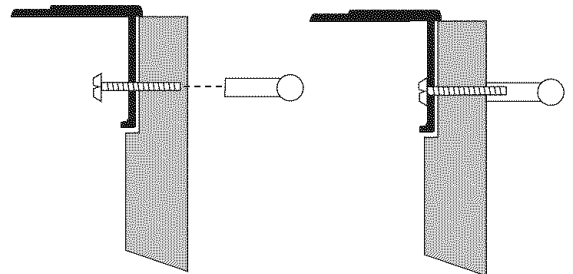

Step 4 Install Assembled Panels

- It is best that 2 people perform this step.*
- Place assembled panel onto the bottom door trim with support bracket tabs inserted into slots.
 - Push and hold the panel back against the steel door with door handle extrusion flush to the handle side of the door.
 - Reinstall original screws into the door extrusion.
 - Open the door fully to stop.
 - Install screws at the top and hinge side.

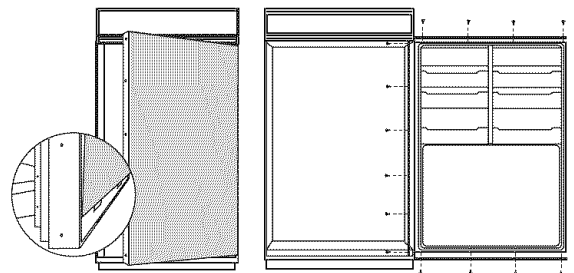

ZUG75 Trim Kit

Unified 3/4" Custom Grille Panel Kit

This kit provides for the installation of a 3/4" thick custom grille panel to span the combined width of a side by side installation. Use this kit in combination with 3/4" custom panel kits, ZKTR36LH and ZKTR36RH.

Completion Time: Allow approximately 3 hours to install this kit.

IMPORTANT: 2 People are required to install this kit.

CAUTION: Disconnect power before you begin.

Tools and materials Required:

- #1 and #2 Phillips screwdrivers or sockets
- 1/4" angled wrench and 1/2" open-ended wrench
- Drill and appropriate bits
- Custom grille panel
- Safety glasses
- Gloves to protect against sharp edges

Parts List:

- A. Soffit Vent Top
- B. Left Side Case Trim
- C. Right Side Case Trim
- D. Center U-Shape Trim
- E. Grille Base Wrap
- F. Custom Grille Panel Support
- G. Foam Spacer Pads

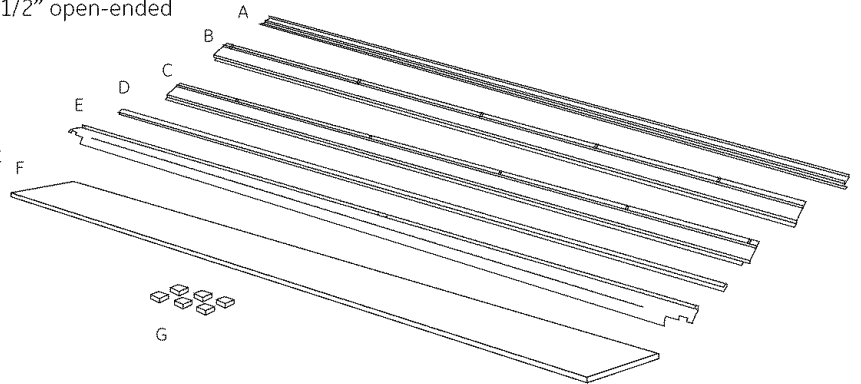

Step 1
Install Spacer Pads,
Replace Side Case Trims

CAUTION: Handle parts with care to avoid scratching.

In a side by side installation, the inside case trim of both products will be removed and replaced with a shorter trim.

- Lift up to remove the supplied grille panel assembly on both products. Discard both assemblies.

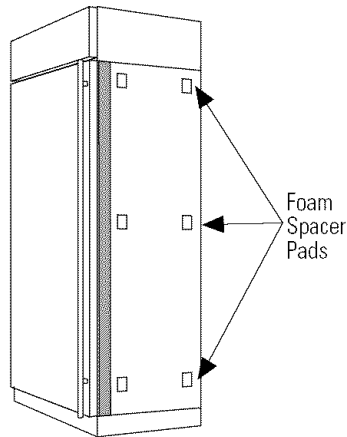

- Apply the supplied foam spacer pads to the mating side of one product as shown.

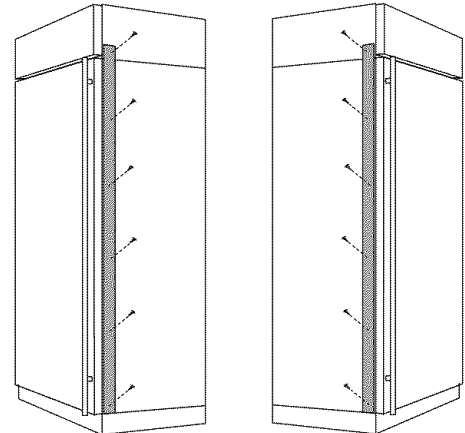

- Remove the Phillips head screws from the inside case trim of each product as shown. Remove and discard side trim. Retain screws.

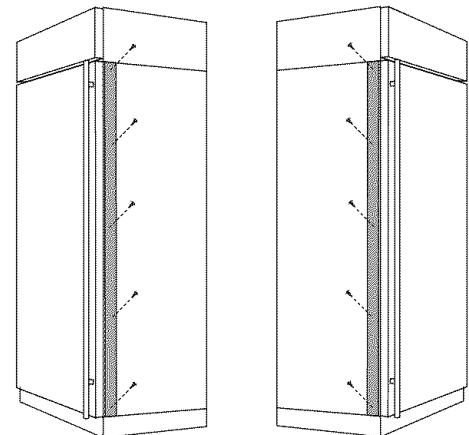

- Install new side case trim with notches towards the bottom. Install with original screws.

Step 2 Install Anti-Tip Brackets

WARNING

ANTI-TIP PRECAUTIONS

These products are heavy at the top and must be secured to prevent the possibility of tipping over.

ATTENTION

PRECAUTIONS CONTRE LES BASCULEMENTS

Le réfrigérateur est beaucoup plus lourd en haut et il faut le maintenir en place pour éviter la possibilité de son basculement vers l'avant.

- Cut a 2"x4" block, 71" long. Secure the 2"x4" to the 4 mounting brackets provided using #12 or #14 wood screws.
- Secure the brackets with wood block to the back wall so that it is 84" (or your installation height) from the finished floor. Use #12 or #14 wood screws. See illustration.
- Screws must penetrate at least one inch into vertical wall studs.

Roll Both Products into Opening

- Gently push each product into opening with hands against front corners. Push back into the opening until it is flush or semi-flush with adjacent cabinets.

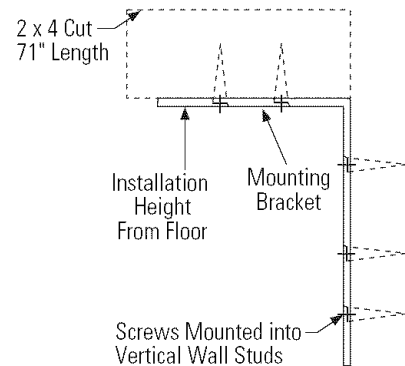
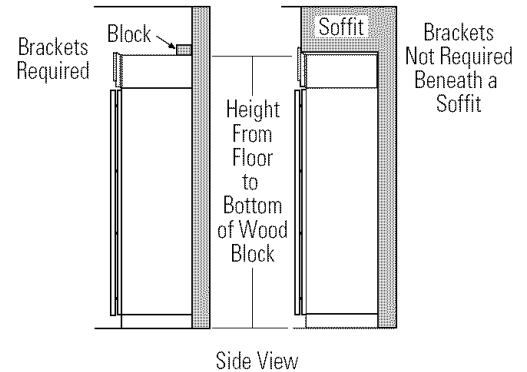

IMPORTANT NOTE: When the products are installed under a soffit or if there is not enough height for this method of security, use Step 4 as an alternative. **The refrigerator and freezer must be secured to prevent tipping.**

Step 3 Level Both Products

Both products **MUST BE LEVEL AND PLUMB** with each other and adjacent cabinetry on each side. Toekick heights should align with cabinetry.

- Adjust carefully. Both models have 4-point leveling. The front is supported by leveling legs, the rear is supported by wheels.
- Raise units to the same level, aligning with adjacent toekick heights.
- Adjust rear wheels beneath the product to just barely touch the 2x4 block.
- Turn the 7/16" hex nut located above the front wheels to raise or lower the back of the refrigerator.
- To adjust the front leveling legs: Use a 1/4" angled wrench to turn the top of the leveling leg, or turn the bottom of the legs with a 1-1/4" wrench.

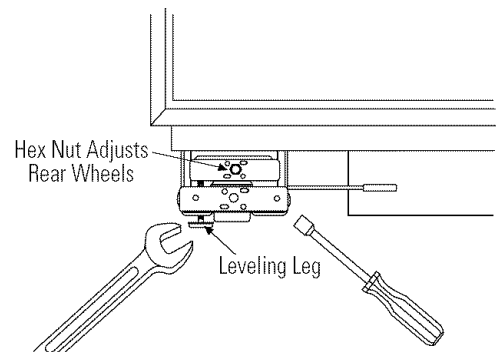

Units must be 1" apart and evenly aligned at top and bottom. The inside case trims must align, top and bottom.

CAUTION

The rear leveling wheels and front leveling legs are limited to a maximum height adjustment of 1". If the installation requires more than 84-1/2" height, the installer should elevate the refrigerator on a sheet of plywood or runners. Cabinetry trim could also be added across the top of the opening to shorten the opening. **If you attempt to raise the refrigerator more than 1", you will damage the front leveling legs and the rear leveling wheels.**

PRUDENCE

Les roues de nivellement arrière et les pattes de nivellement avant permettent un réglage maximal de 25 mm (1 po). Si l'ouverture pour le réfrigérateur a une hauteur supérieure à 2,15 m (84-1/2 po), l'installateur doit élever le réfrigérateur sur une feuille de contre-plaqué ou des glissières. Il est également possible d'ajouter des baguettes de finition des placards sur le haut de l'ouverture afin de la réduire. **Lever le réfrigérateur de plus de 25 mm (1 po) endommage les pattes de nivellement avant et les roues de nivellement arrière.**

ZUG75 Trim Kit

Unified 3/4" Custom Grille Panel Kit

Step 4 Secure Products To Sides

NOTE: This step can be used as an alternative to Step 2, Anti-Tip bracket installation, whenever brackets cannot be used. Whenever possible, perform this step for additional anti-tip security.

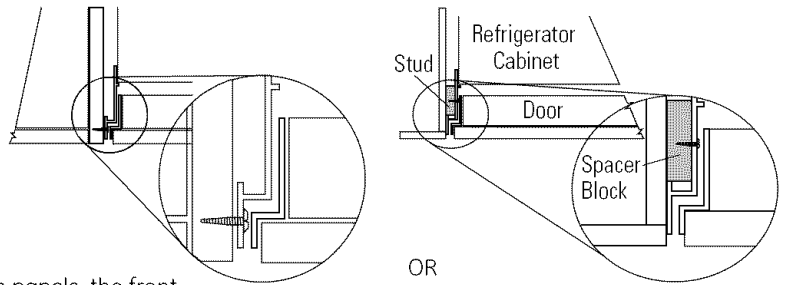

When using 1/2" to 3/4" thick side panels, the front flange of the case trim is attached to the side panel.

- Open door to access case trim.
- Drill hole in trim slightly below the interior opening.
- Drive screw through the trim and into the side panel.
- Follow the same procedure on the opposite outside product trim.

If the product is installed between cabinets with no side panels or into a custom enclosure, install a spacer block as shown.

Step 5 Install Center Trim Strip

- Open doors fully.
- Starting at the top, press trim strip over inside case trims of both products.
- Continue pressing trim until you reach the bottom of the case trims. The trim will align with the top and bottom of the case trim.

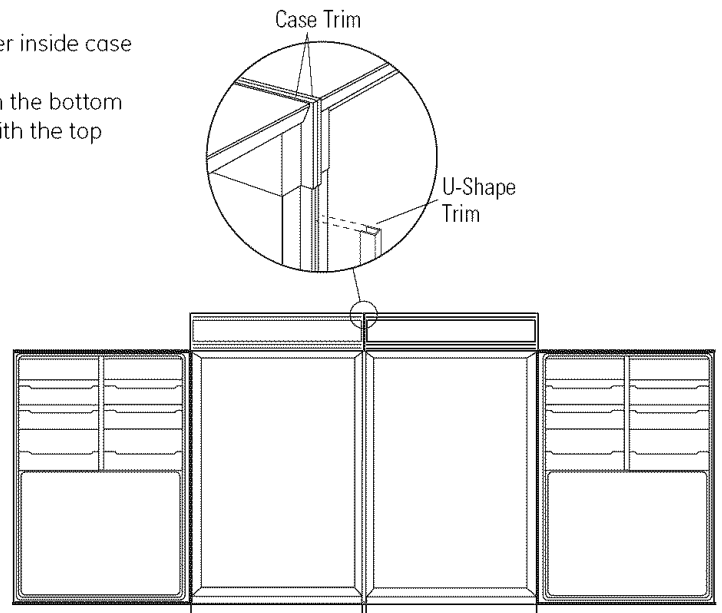

Step 6 Remove Wire Fence and Switch Cover

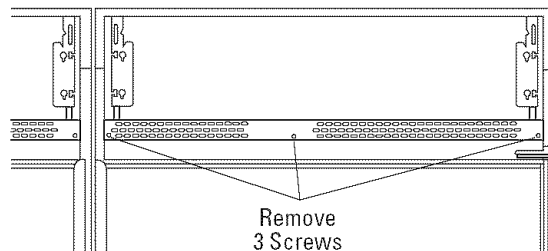

Remove
3 Screws

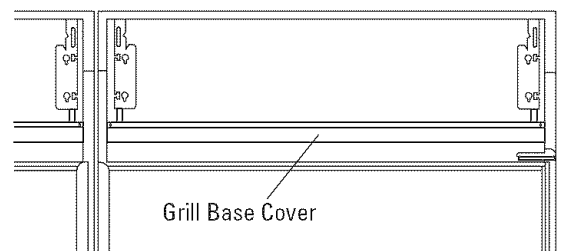

Grill Base Cover

- Remove 3 screws holding the wire fence on both products. Retain fences and all screws.

- Lift off grille base covers. Discard covers.

ZUG75 Trim Kit

Unified 3/4" Custom Grille Panel Kit

Step 7 Install Grille Base Cover

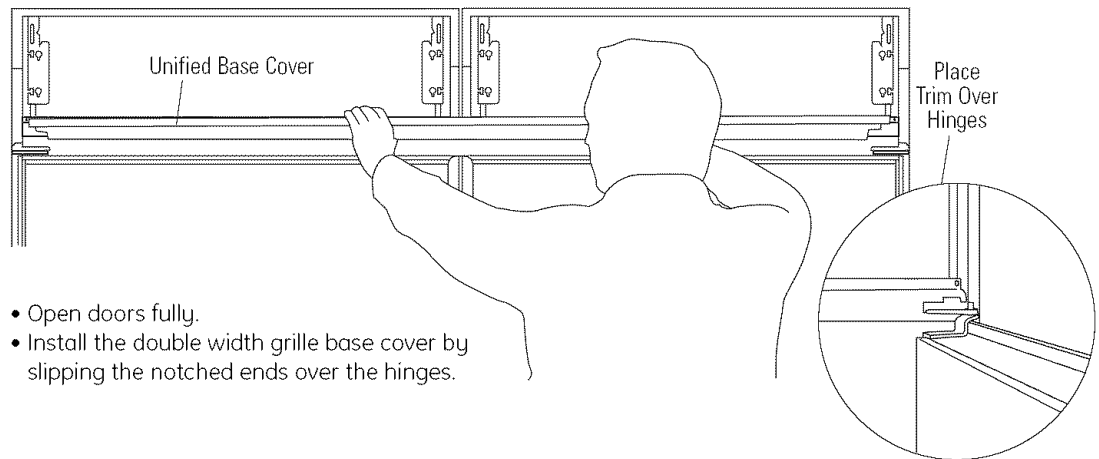

- Open doors fully.
- Install the double width grille base cover by slipping the notched ends over the hinges.

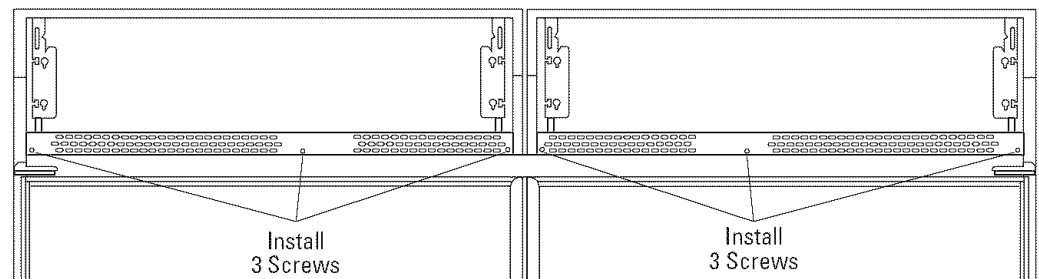

- Place wire fence over the grille base cover (textured side out). Drive original wire fence screws through the fence, the grille base cover and into the frame.

Step 8 Remove Grille Frame

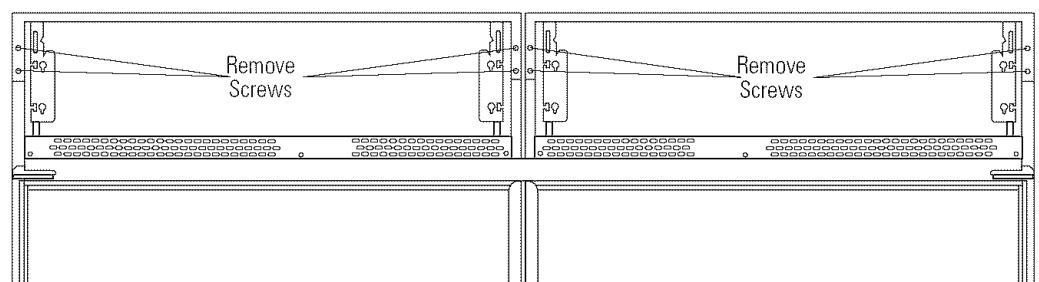

- Back out 2 screws on each side of the top case trim.
- The top piece is secured to the unit with a rubber dust gasket. Roll the trim upwards to access and remove end screws as shown. Remove and discard inside pieces.
- Slide assembly out of the rubber gasket.

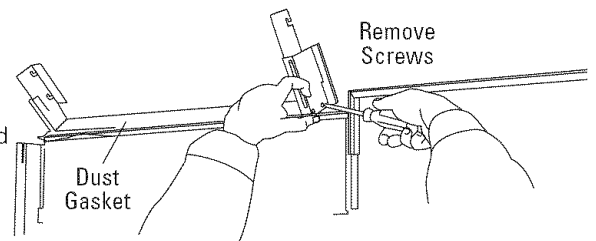

ZUG75 Trim Kit

Unified 3/4" Custom Grille Panel Kit

Step 9 Install Soffit Vent Top

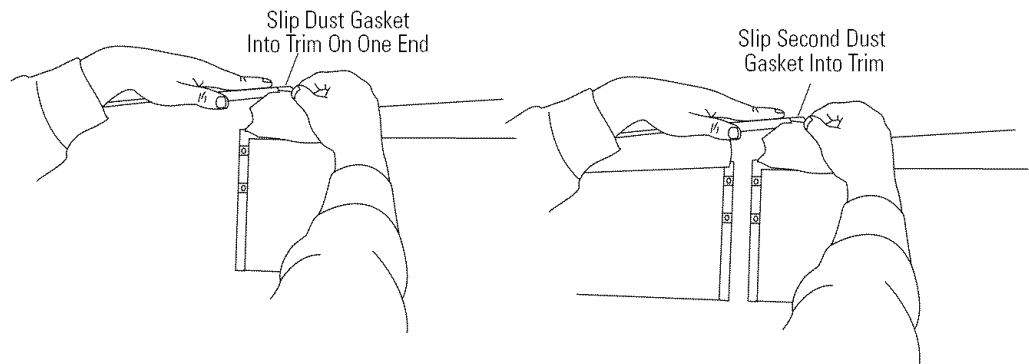

- Separate the top and hinge side trim pieces by removing side screws. Discard top piece, retain screws.
- Install one end piece to unified top piece with 2 original screws.
- Slip end of rubber dust gasket into end of top unified piece and slide trim towards the center. Engage the second piece of gasket and continue sliding trim until even with opposite ends.
- Reinstall end pieces to case trims. Push top piece up against soffit or to installation height. Tighten screws on both sides.
- Whenever possible, place a level on the top trim. Adjust side trims until entire grille frame is level.

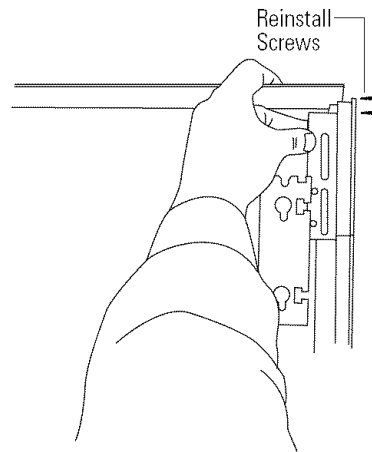

Step 10 Secure Custom Panel To Support

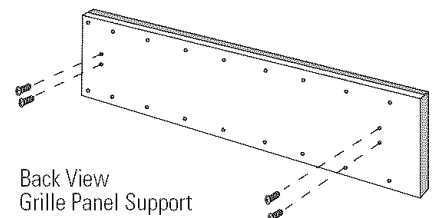
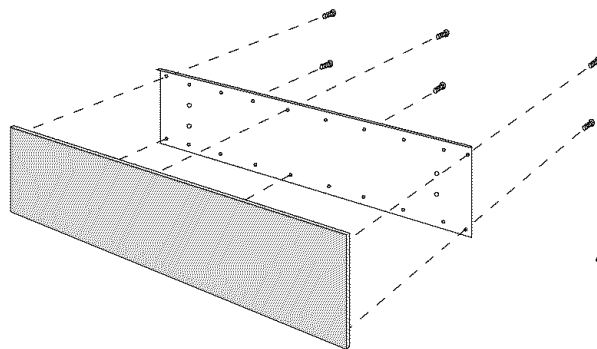

- Secure the grille panel support to the back side of the 3/4" thick custom panel with #6 screws. Be sure the lip of the support is over the top of the wood panel.

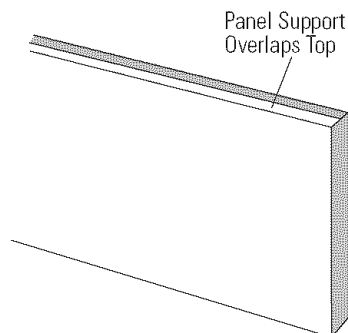

- Install four of the six larger undercut screws so that the top of the screws are 1/16" from the surface of the support.

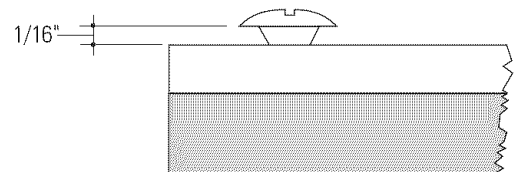

- Attach the assembled panel to the grille opening by inserting the four protruding screws into the brackets on each side.

NOTE: Use screws supplied with ZKTR36 Trim Kits.

Step 11
Adjust
Door
Alignment

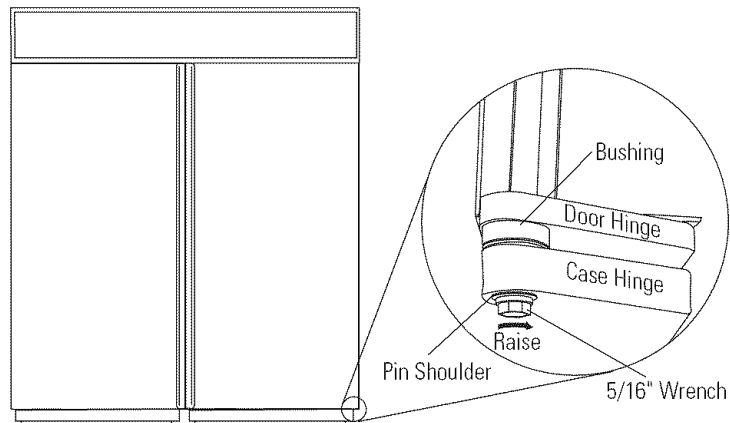

Check door alignment. The top of the door should be parallel with the grille panel. If the door appears to be too high or too low on the handle side, adjustments can be made.

- Use a 5/16" wrench to turn the hinge.
- To raise the door, turn adjustable hinge pin towards the right.
- To lower the door, turn hinge pin towards the left.

NOTE: While performing installations described in this book, safety glasses or goggles should be worn.

For Monogram® local service in your area, call 1.800.444.1845.

NOTE: Product improvement is a continuing endeavor at General Electric. Therefore, materials, appearance and specifications are subject to change without notice.

