

INSTRUCTIONS

MODEL 1249 • ZIG • ZAG SEWING MACHINE



Sears, Roebuck and Co.

Dear Homemaker:

You have just invested in a very fine stretch stitch sewing machine. Before using your new Kenmore machine, please pause for a moment and carefully read this booklet which contains instructions on how to operate and care for your machine.

Specific instructions are given on threading, tension adjustments, cleaning, oiling, etc. This will help you obtain the best sewing results and avoid unnecessary service expense for conditions beyond our control.

Advice on the operation and care of your machine is always available at your nearest Sears Retail Store.

Please remember, any correspondence or reference to your machine must mention the model number and serial number of your machine.

Kenmore Sewing Machine

Record in space provided below the model number and serial number of this appliance. The model number and serial number are located on the nomenclature plate, as identified on Page 3 of this booklet.

Model No. _____ Serial No. _____
Retain these numbers for future reference.

**TABLE OF
CONTENTS**

Section I Knowing Your Sewing Machine	
Identifying Parts	2, 3
Installing Machine	4
Converting to Free-arm Sewing	5
Winding the Bobbin	6
Threading the Bobbin Case	7
Threading of Top Thread	8
Using the Controls	
Adjusting Top Tension	9
Adjusting Bobbin Tension	10
Checking Tensions	11
Stitch Width Control	12, 13
Stitch Length Control	12, 13
Reverse Stitch Control	14
Stretch Stitch Control	14
Stitch Selector	15, 16
Pressure Regulator	17
Sewing Light	18
Seam Guides	19
Presser Foot Lever	19
Accessories	
Needles	20
Needle, Thread and Fabric Chart	21
Presser Feet	22
Section II Starting to Sew	1
Garment Construction Stitches	
Straight Stitching	2
Zigzag Stitching	3
Stretch Stitching	4
Special Finishing Stitches	
Buttonhole Making	5
Blind Hemming	6
Satin Stitching, Appliqueing	7
Zipper Application	8
Mending, Darning	9
Button Sewing, Bar Tacking	10
Free-arm Sewing	11
Section III Checking Performance Problems	
Section IV Caring for the Machine	
Cleaning Feed Dogs and Shuttle	1
Oiling Under Arm Cover Plate	2
Oiling Underside	3
Oiling in Face Cover Plate	4
Parts List	5, 6
Memo	7
Warranty	8

Knowing Your Sewing Machine

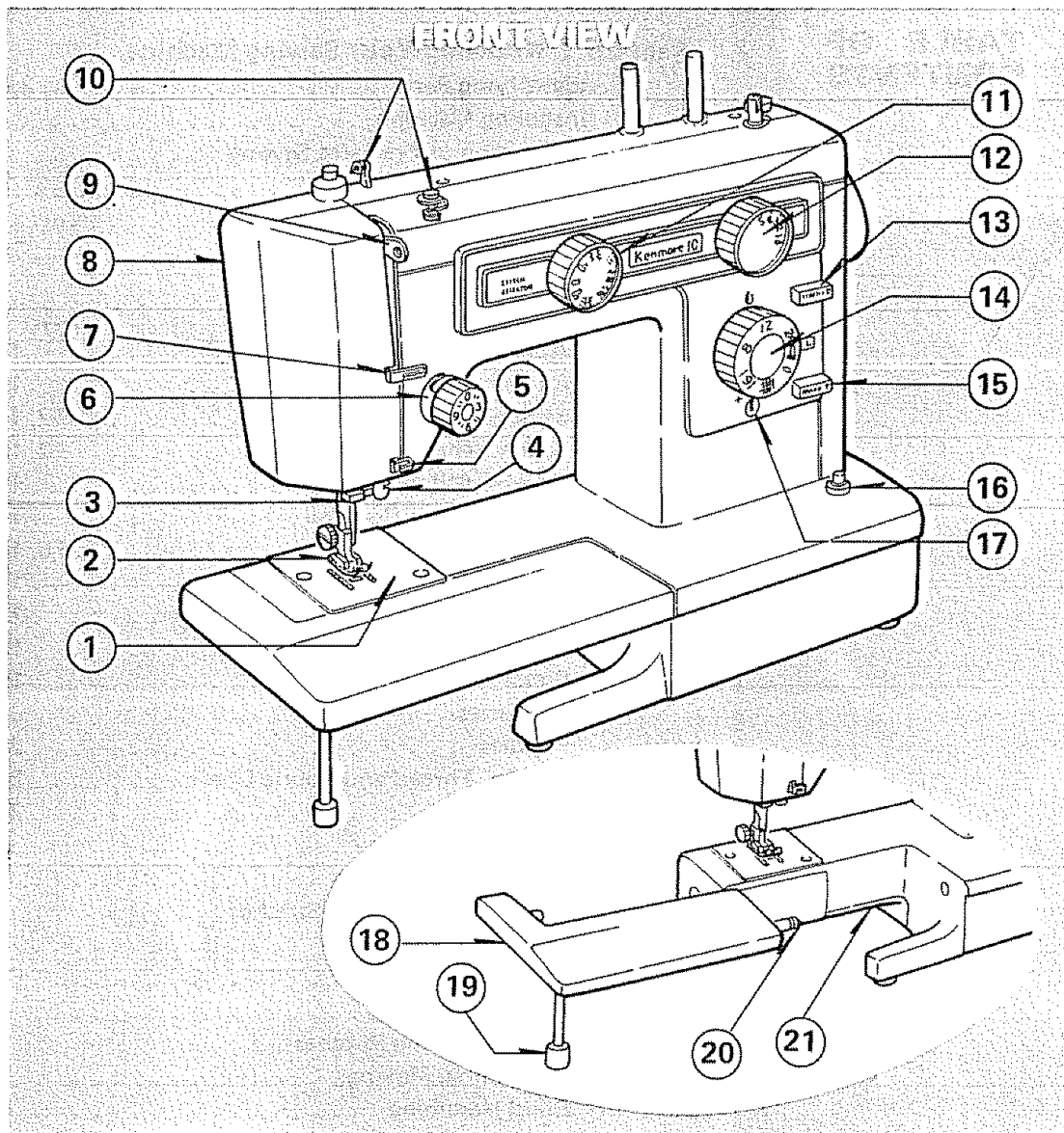

- | | |
|-------------------------------|--------------------------------|
| 1. Needle Plate | 12. Stitch Width Control |
| 2. Presser Foot | 13. Stretch Stitch Control |
| 3. Thread Guide | 14. Stitch Length Control |
| 4. Needle Clamp Screw | 15. Reverse Stitch Control |
| 5. Thread Guide | 16. Light and Power Switch |
| 6. Top Thread Tension Control | 17. Buttonhole Stitch Adjustor |
| 7. Face Cover Thread Guide | 18. Extension Table |
| 8. Face Cover Plate | 19. Support Leg |
| 9. Take-up Lever | 20. Shuttle Cover |
| 10. Upper Thread Guides | 21. Free Arm |
| 11. Stitch Selector | |

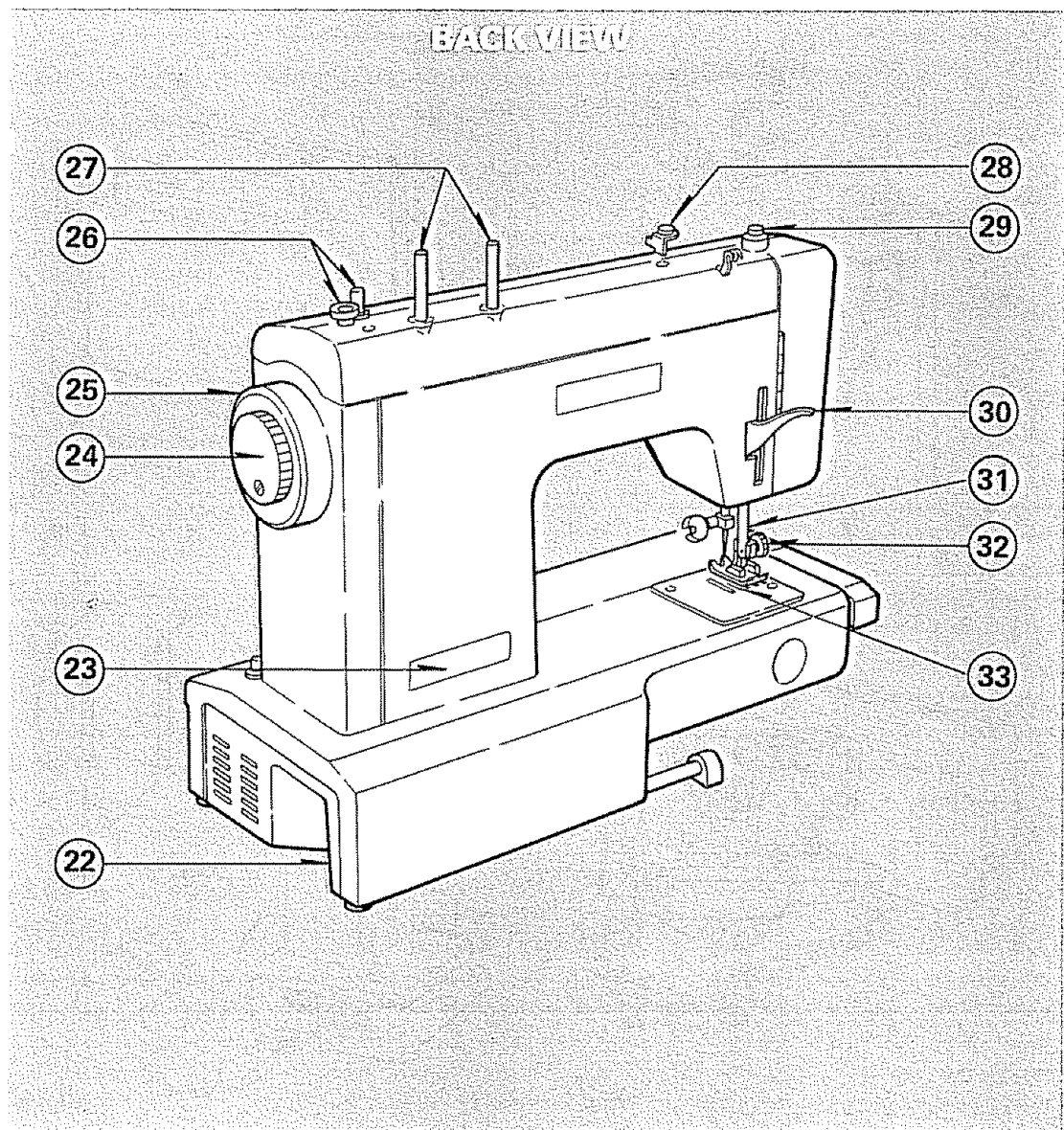

- 22. Electric Cord Receptacle
- 23. Nomenclature Plate
- 24. Clutch Knob
- 25. Hand Wheel
- 26. Bobbin Winder
- 27. Thread Spool Pins

- 28. Bobbin Winder Tension Disc
- 29. Pressure Regulator
- 30. Presser Foot Lever
- 31. Thread Cutter
- 32. Presser Foot Thumb Screw
- 33. Feed Dogs.

INSTALLING MACHINE

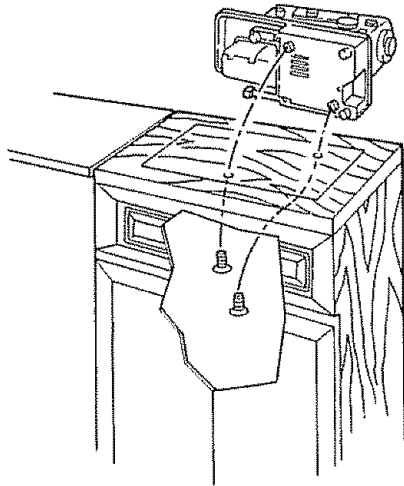

Fig. 1

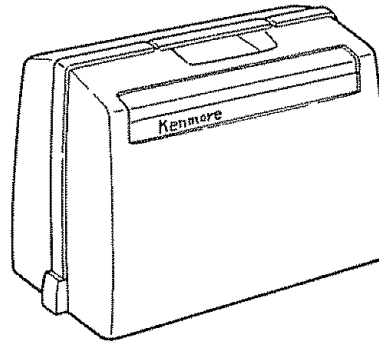

Fig. 3

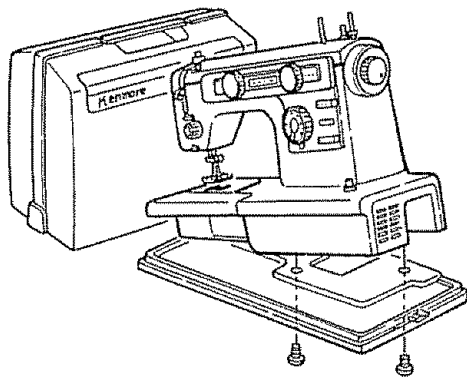

Fig. 2

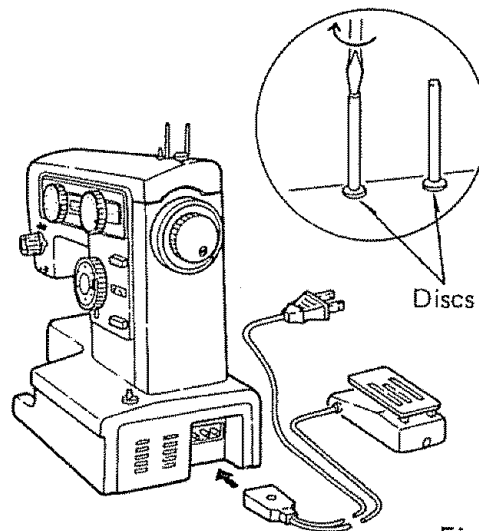

Fig. 4

1. To install the machine in cabinet, position machine head on cabinet platform so that holes on bottom of machine match those on board. Insert washers and screws and tighten into place. (Fig. 1) (Follow instructions provided with Sears Cabinet. Screws and washers are supplied with cabinet.)
2. A separate base and cover is available to carry the machine when needed. To install machine in carrying case, set machine into base, with word FRONT in base facing you. (Fig. 2)

- Place cover on machine with word "SEARS" on handle facing you. The case slopes in the same direction of the machine (Fig. 3)
3. Push the speed control plug onto three-prong connector. Plug machine cord into any 110-120 volt wall outlet. Turn on power by pushing light and power switch. (Fig. 4)
 4. Spool pins are packed in accessory box. Screw thread spool pins in place securely with a screw driver. Position nylon discs as shown in illustration.

CONVERTING TO FREE-ARM SEWING

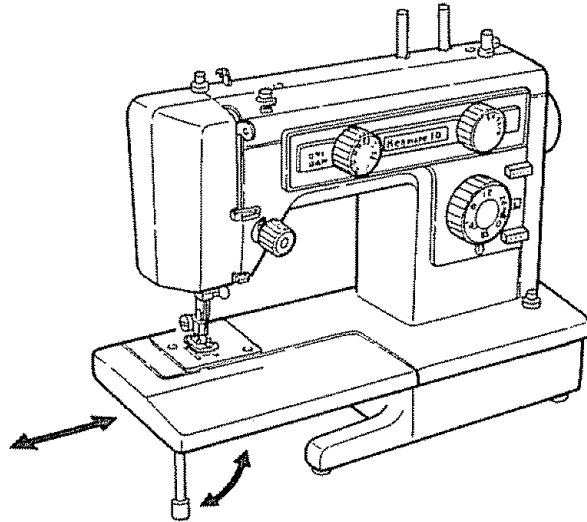

Fig. 1

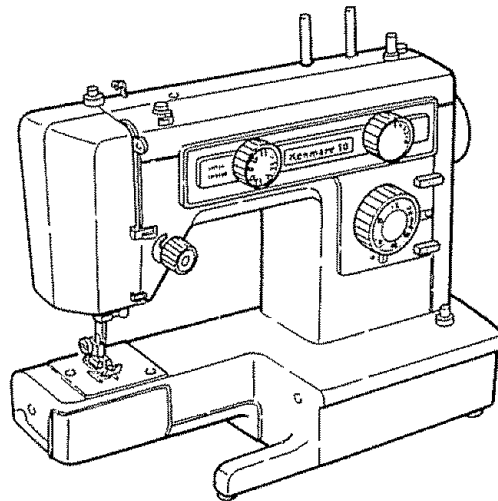
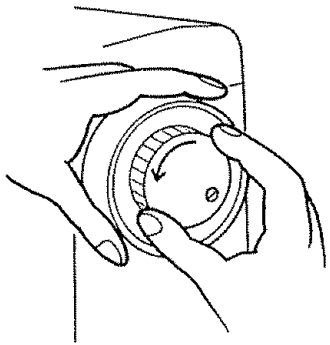

Fig. 2

1. Remove the extension table from the machine by folding the support leg up and pulling table to the left. (Fig. 1,2)
2. To replace the table, simply slide it along the free arm to its original position and place supporting leg in down position. (Fig. 1)

WINDING THE BOBBIN



①

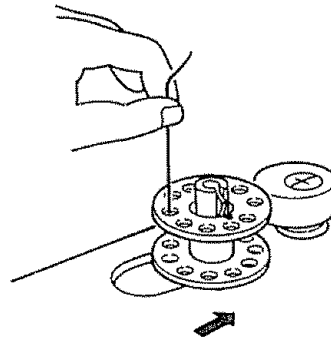

④

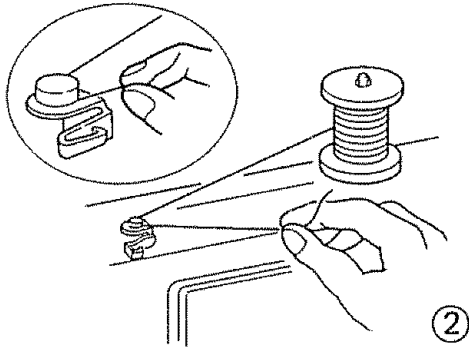

②

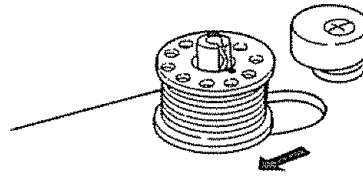

⑤

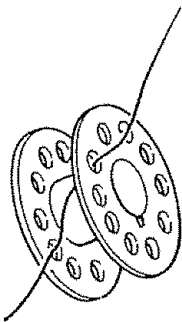

③

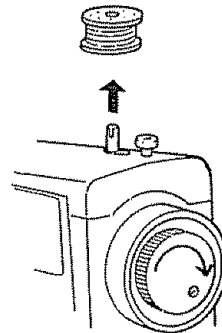

⑥

1. Release clutch by turning clutch knob toward you.
2. Draw thread from spool through bobbin winder tension disc as shown.
3. Pull end of thread through hole in bobbin as shown.
4. Place bobbin onto bobbin winder shaft with end of thread coming

- from the top of the bobbin. Push bobbin winder shaft to the right until it clicks. Holding onto end of thread, start machine. When bobbin is slightly filled, snip off end of thread.
5. Wind thread until winder stops. Remove bobbin. Clip thread.
6. Tighten clutch knob.

THREADING THE BOBBIN CASE

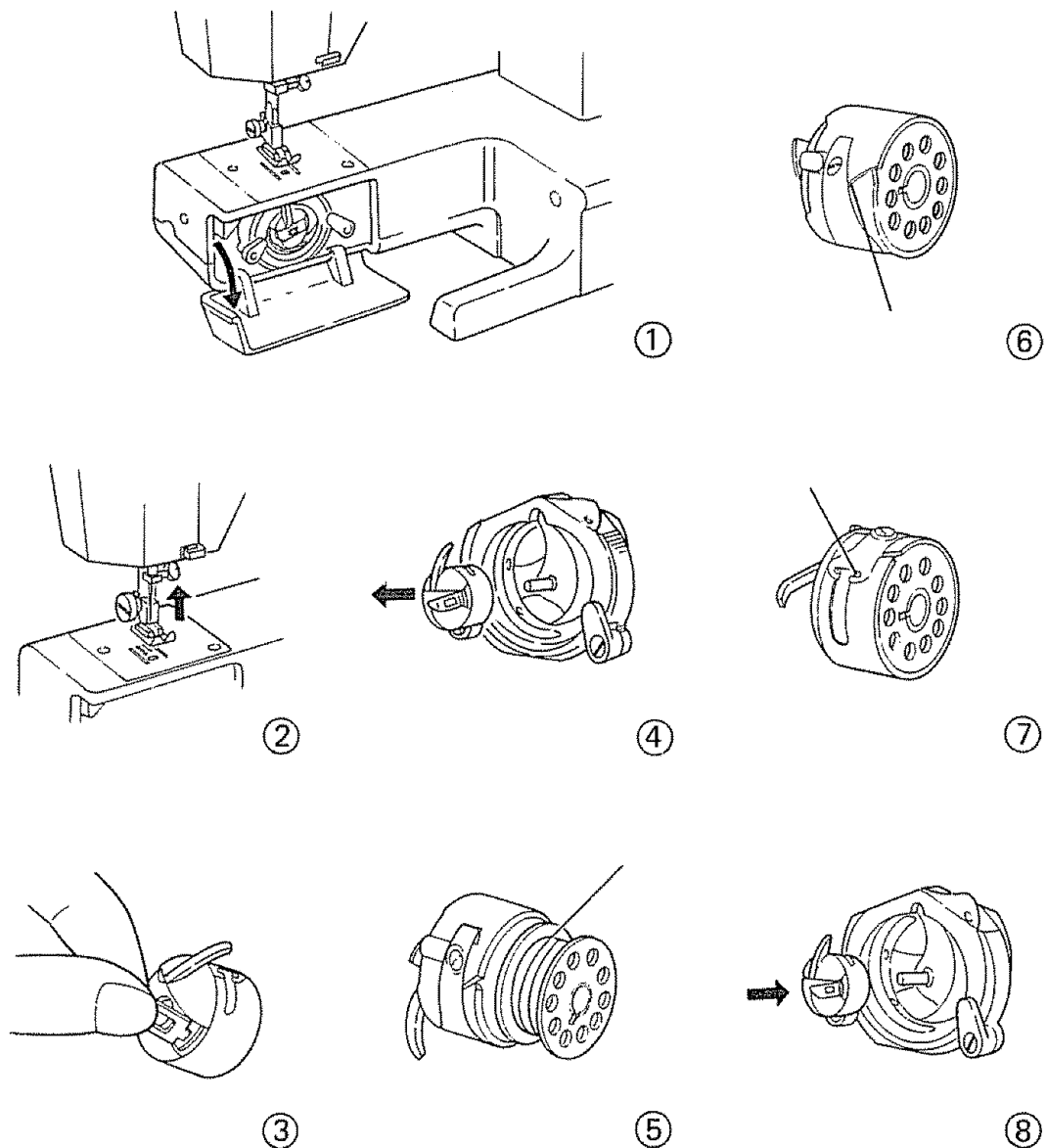

1. Remove the extension table from the machine by pulling it to the left. Open the shuttle cover by pulling down the embossed part on the left side of the cover.
2. Raise needle to its highest position by rotating hand wheel toward you.
3. To remove bobbin case from shuttle, pull open latch of bobbin case.
4. Pull bobbin case straight out of shuttle.
5. Insert bobbin into bobbin case making sure thread is coming from bobbin as shown.
6. Pull thread through slot of case as shown.
7. Pull thread under tension spring.
8. Holding latch open, position case into shuttle, and release latch. Case should lock into place when latch is released.

THREADING OF TOP THREAD

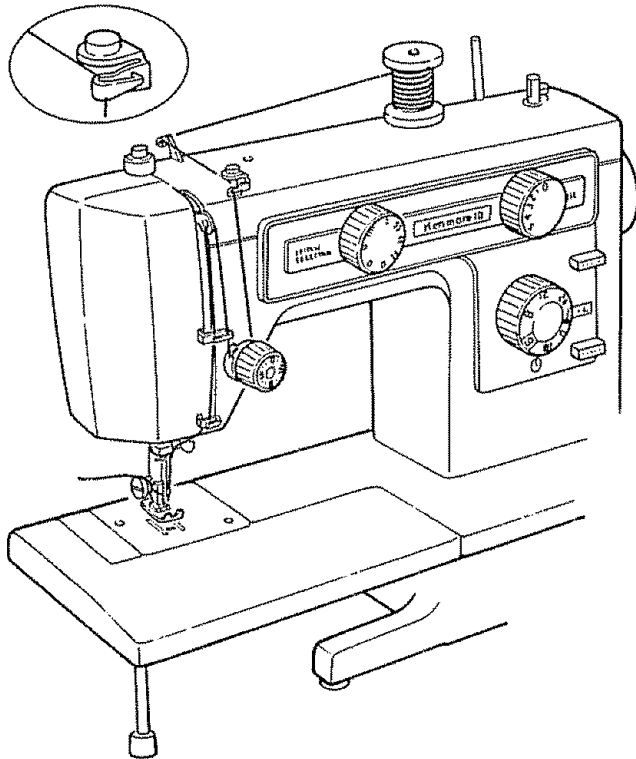

Fig. 1

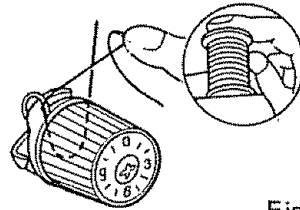

Fig. 2

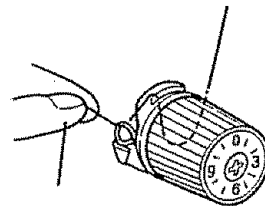

Fig. 3

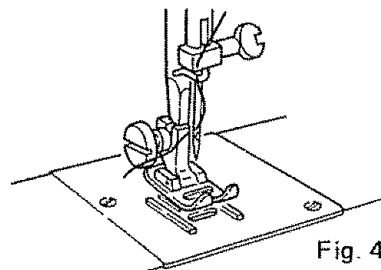

Fig. 4

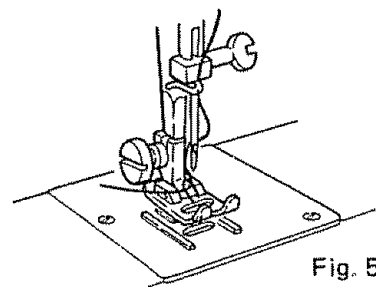

Fig. 5

Place thread on spool pin as shown with thread coming from the back of the spool. Draw thread through the top thread guides. Holding the spool stationary with right hand, pull the end of the thread between the tension discs as shown. Pull the spring wire loop up and past the top hook until the thread can be slipped into the hook (See Fig. 2). When the thread is released, the spring wire loop will re-

turn to position (See Fig. 3) with thread in proper place. Release spool of thread and continue to thread machine exactly as shown. Needle must always be threaded in direction as shown in Fig. 4.

Hold needle thread loosely in left hand and rotate hand wheel toward you one complete turn. Bring bobbin thread up by pulling upper thread. (Fig. 5).

CONTROLS

ADJUSTING TOP TENSIONS

Probably the most important control on your machine is this one that regulates your top thread tension. It consists of discs between which the thread passes. The pressure on these discs is regulated by turning the dial. The higher the number, the tighter the tension.

There are many reasons for having to reset your tension. The best tension for one fabric may not be correct for another. The required tension depends upon the stiffness of the fabric, thickness of the fabric, numbers of layers of fabric being sewn, as well as the type of stitch you are making.

It is best to test the stitching on a scrap of the fabric you are using before starting to make a garment.

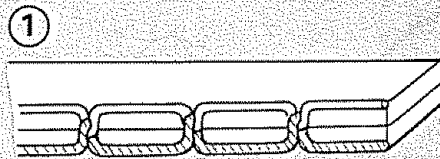

A perfect straight stitch will have threads locked between the two layers of fabric with no loops on top or bottom.

② Upper thread too tight

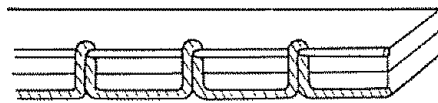

Decrease Tension

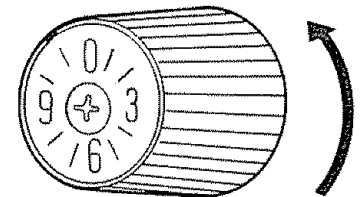

③ Upper thread too loose

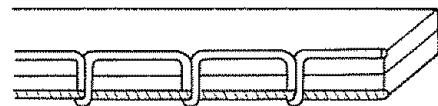

Increase Tension

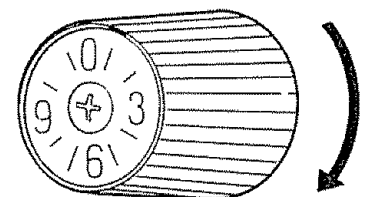

ADJUSTING BOBBIN TENSIONS

Bobbin tension requires adjusting less frequently than the upper thread tension.

If the stitch is satisfactory but the seam is puckered, it may be necessary to loosen the tension on both the top and bottom threads. Be sure to balance them as indicated on Page 9.

When adjusting the tension on the bobbin case, make slight adjustments with a screwdriver.

DECREASE TENSION

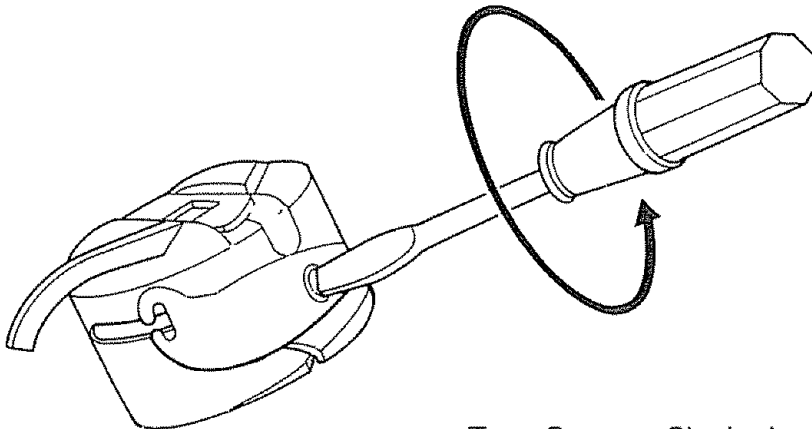

Turn Counter Clockwise

INCREASE TENSION

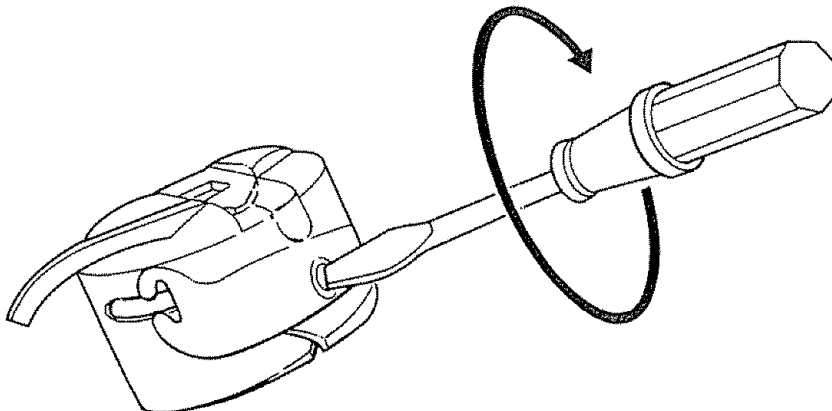

Turn Clockwise

CHECKING TENSIONS

The easiest way to check tensions is to sew a medium zig zag stitch on the fabric you will be using. Use the appropriate type of thread and needle. Use different colors of thread on the bobbin and upper spool

Sew a line of medium zig-zag stitches. The bobbin thread should not show on the top of the fabric.

Adjust the top tension if necessary to achieve the stitch formation mentioned above.

UNDESIRABLE

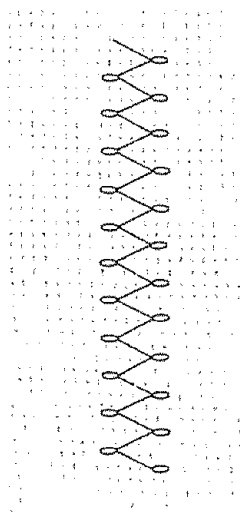

DESIRABLE

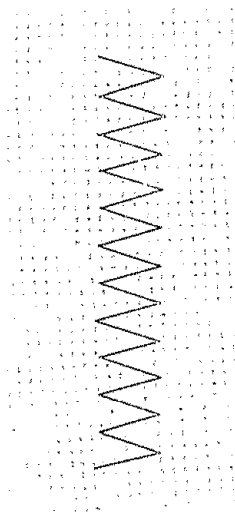

TOP SIDE OF FABRIC

This control regulates the width of the stitch you select. **THE HIGHER THE NUMBER-THE WIDER THE STITCH.** You may vary your zigzag stitch width by adjusting this control to the setting you desire.

This control must be set on "0" position in order to do straight stitching.

The stitch length control regulates the length of the stitch you select. **THE HIGHER THE NUMBER-THE SHORTER THE STITCH.**

The number on stitch length control indicates the approximate number of stitches per inch. The stitch setting you use will be determined by the thickness of the fabric you are sewing.

A longer stitch setting should be used for thicker fabric or more layers of fabric. The middle range of the control is the 10-12 stitch per inch range which is the most commonly used.

A basting stitch is made by using the longest possible stitch setting-6 stitches per inch.

The white & green marking  on the control is the setting used for the shortest stitches such as in Satin Stitching.

The marking  on the control is the setting used for darning or embroidering.

STITCH WIDTH CONTROL

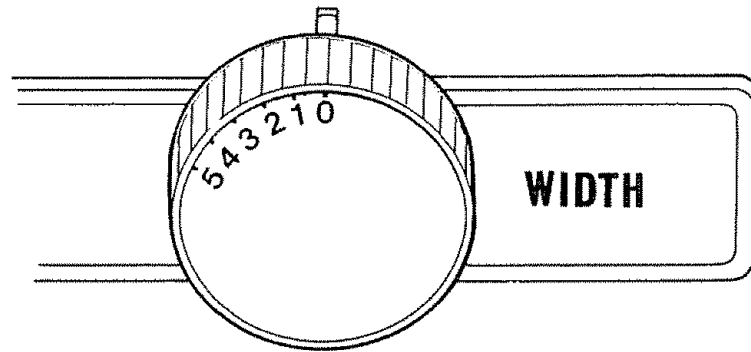

STITCH LENGTH CONTROL

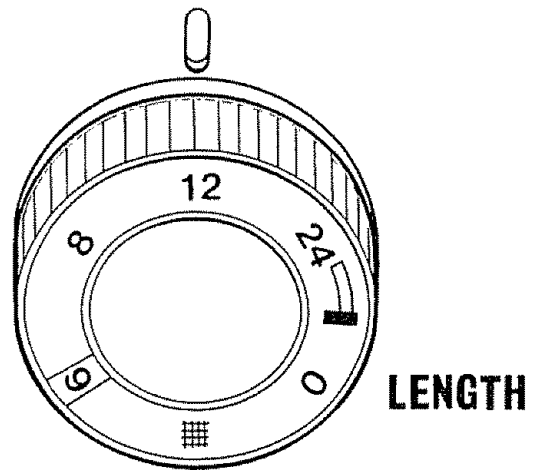

REVERSE STITCH CONTROL

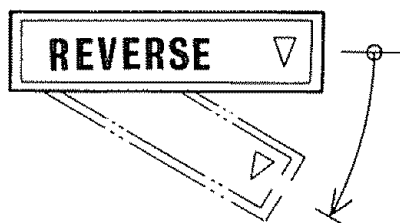

It is best to begin and end seams with a few stitches taken in reverse. This is called back tacking. Back tacking fastens the ends of the seams firmly and prevents raveling.

When reverse stitching is needed, turn the control clockwise and hold there during sewing. The fabric will immediately start feeding backwards and seam will be fastened.

STRETCH STITCH CONTROL

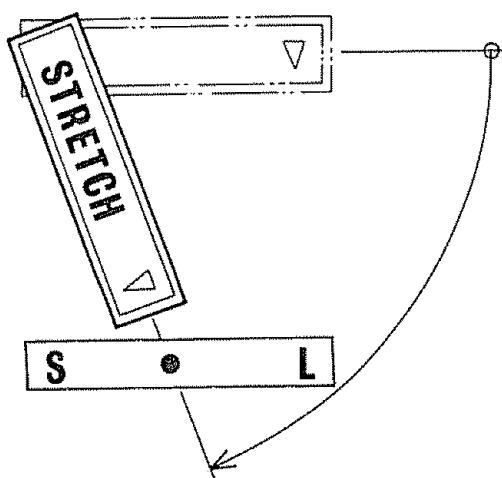

This control determines the feed of the feed dogs. All simple forward stitches require that this control be set at horizontal position. These stitches are the straight, zigzag, blind, mending, shell stitch and buttonhole sewing. For more detail about this control see Section II, Page 4d.

Straight stretch, rickrack stretch, overcast stretch, smocking stretch and serging or pine leaf stretch stitches require the control to be set at middle position between S and L.

STITCH SELECTOR

There are certain types of stitches that are used more often than others in your garment construction. Because of their frequent use, you will soon realize the convenience offered to you by this control. The desired stitch will be obtained by turning the Stitch Selector Dial.

All stitches printed in yellow on the dial must be sewn with Stretch Stitch Control set at the middle position between S and L.

Stitches printed in orange on the dial may be obtained with Stretch Stitch Control set at horizontal position.

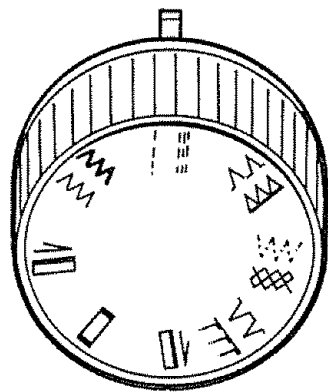

STRAIGHT STITCH AND STRAIGHT STRETCH STITCH

The setting illustrated is the one used for most of your stitching. At this setting you may make straight stitch and straight stretch stitch.

As each stitch is dependent upon the setting of your other controls, carefully read the directions in the next section of the book for various stitches.

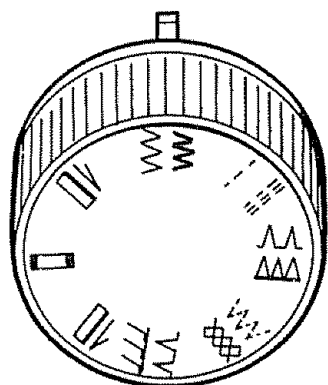

ZIGZAG STITCH AND RICKRACK STRETCH STITCH

At this setting illustrated, you may sew a simple zigzag stitch or a rickrack stretch stitch.

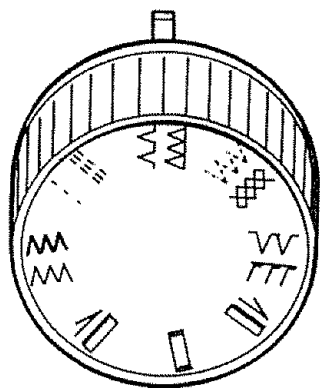

BLIND STITCH AND OVER-CAST STRETCH STITCH

Blind hems are made by using the setting shown with the Stretch Stitch Control at horizontal position. When Stretch Stitch Control is set on middle position between S and L, overcast stretch stitching is made.

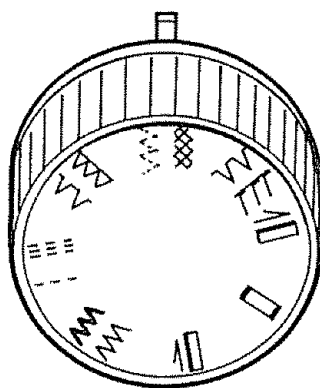

MENDING STITCH AND SMOCKING STRETCH STITCH

You will find that much of your sewing in the mending category. For this reason you have been provided with a stitch for the repair of tears. It is accomplished at the illustrated setting with Stretch Stitch Control at horizontal position. When the Stretch Stitch Control is turned to middle position between S and L, a smocking stitch is obtained. For directions, see the next section of this book.

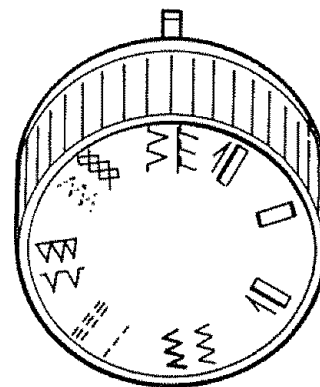

SHELL STITCH AND SERGING OR PINE LEAF STRETCH STITCH

Serging or pine leaf stretch is used for seam finishing on all types of fabrics. It is a stitch used in the garment industry. It forms a good looking seam, stitching and overcasting the edges. This stitch is useful for seaming of swimwear, stretch ski pants and other types of knit sportswear. The stretch Stitch Control must be set on middle position between S and L. If the Stretch Stitch Control is set at horizontal position, a shell stitch can be made.

OTHER ADJUSTMENTS OF MACHINE IN SEWING

In addition to the obvious controls of your machine, there are other small regulators and controls to aid you in using your sewing machine.

PRESSURE REGULATOR

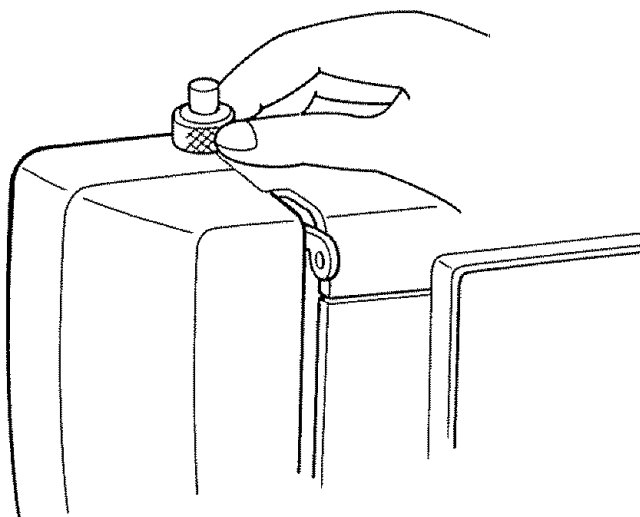

Push down the outer ring of the pressure regulator. This will release the pressure on the presser foot. (See above).

To increase the pressure, push down inner pin until a suitable pressure is obtained.

Insufficient pressure may cause poor feeding of the fabric, skipped stitches, or difficulty in guiding the fabric. If feed dogs or presser foot marks appear on the fabric, reduce the pressure.

When sewing multiple thickness or heavy fabric, reduce the pressure. Increase pressure when sewing lighter weight fabrics.

SEWING LIGHT

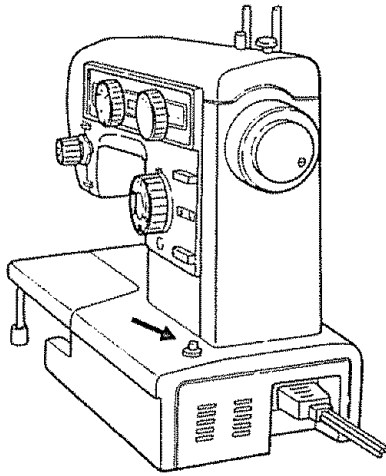

Fig. 1

The light and power switch shown in Fig. 1 provides the electric current for the motor as well as the light. In order to operate the machine, this switch must be on.

To turn on the light, depress the switch. If you are interrupted while sewing and must leave the machine unattended, just turn off the switch and the machine cannot be started accidentally.

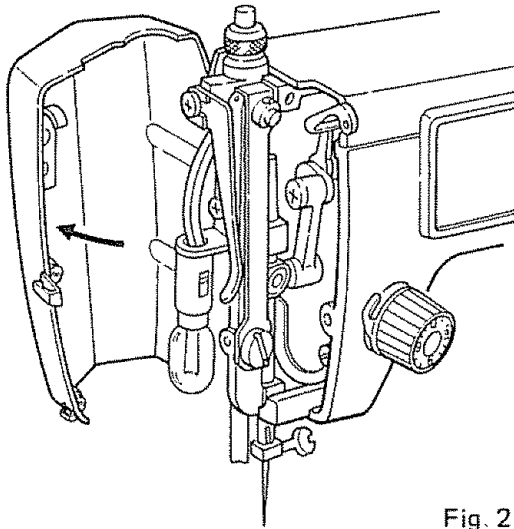

Fig. 2

The sewing light is located in the face cover as shown. To replace the bulb, turn the light off and open the face cover. Push the bulb up and turn the bulb counter-clockwise and remove it from the socket.

Push a new bulb in and turn it clockwise.

NOTE:

First, unplug the machine prior to removing and replacing the bulb. Be aware that the light bulb may be warm.

SEAM GUIDES

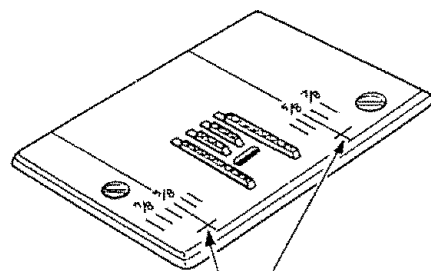

Cornering Guide

Seam guides are printed on either side of the needle plate to aid you in guiding your fabric. THE GUIDE LINE EXTENDING ALONG THE RIGHT SIDE OF THE NEEDLE PLATE IS THE "ALL IMPORTANT" 5/8" SEAM LINE.

The cornering guides are convenient when turning a square corner 5/8" from the fabric edge. See next section of this book for directions.

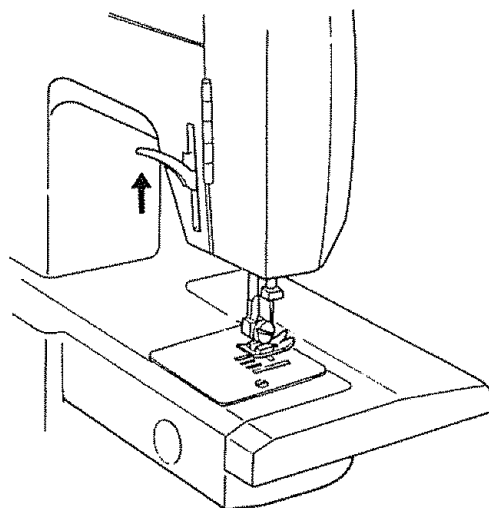

PRESSER FOOT LEVER

To aid you in the placement of heavy fabrics under the presser foot, the lever can raise foot beyond the normal "up" position. This is also an aid in changing your presser feet.

ACCESSORIES

NEEDLES



Use KENMORE needles. The size of the needle should conform with the size of the thread and both should be suitable to the fabric (See next page).

Never use a bent needle or one with a blunt point.

Fig. 1. shows you the exact length of your needle. Be sure you never use one in your machine that is not this exact length.

"Q Needle" with blue shank is available at any store or service center of Sears Roebuck and Co. This special needle is to be used when sewing certain knits and difficult synthetic fabrics. If you experience skipped stitches in any of your sewing, use "Q Needle".

PLACEMENT OF NEEDLE

Raise needle bar to its highest position by turning the hand wheel toward you. Loosen the needle clamp screw. Holding the needle with the flat side away from you, slip the needle into the needle bar. When it is in as far as it will go, tighten the needle clamp screw with a screwdriver.

Flat
side
away
from
you

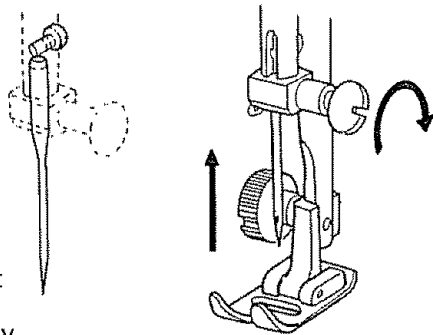

NEEDLE, THREAD AND FABRIC CHART

FABRIC	NEEDLE SIZE AND COLOR	THREAD SIZE	RECOMMENDED STITCH LENGTH SETTING
Lightweight: Batiste, Dimity, Chiffon, Silks, Synthetic Jerseys, Fine Lace, Organza, Crepe, Taffeta, Voile, Organdy	9-BROWN or 11-ORANGE	Polyester Core/Cotton Wrap Fine Mercerized Cotton Silk A	12 stitches per inch
Medium Weight: Cotton, Cotton Blends, Percale, Gingham, Shantung, Pique, Seersucker, Satin, Knits, Vinyl Suitings, Linen, Wool Crepe, Leather	14-RED	50 Mercerized Cotton Polyester Core/Cotton Wrap Silk A	10 to 12 stitches per inch
Medium Heavy Weight: Corduroy, Denim, Wool, Sailcloth, Wool Flannel, Gabardine, Velvets, Leather	14-RED or 16-PURPLE	50 Mercerized Cotton Mercerized Heavy-Duty Polyester Core/Cotton Wrap Silk A	8 to 10 stitches per inch
Heavy Weight: Coatings, Upholstery Cotton Duck, Heavy Twills, Canvas	18-GREEN	Heavy Duty Mercerized Cotton Polyester Core/Cotton Wrap Silk A	8 stitches per inch
Decorative top-stitching on all types of fabric	16-PURPLE 18-GREEN or Q-BLUE	Buttonhole Twist (Use as top thread only)	6 stitches per inch
Synthetic Knits and Stretch: Polyester Double Knits, Nylon Tricot, Jersey, Stretch Terry, Spandex, Cire Tricot	Q-BLUE with Q FOOT™	Polyester Core Cotton Wrap 50 Mercerized Cotton	10 for Regular or 6 for Stretch Stitches

PRESSER FEET

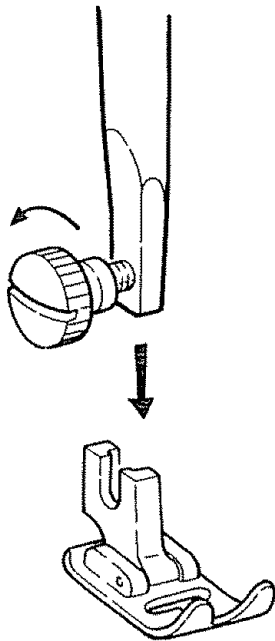

To change the various presser feet, raise the presser bar to its highest position by lifting the presser foot lever. Loosen the presser foot thumb screw, choose the proper foot, insert from the bottom. Tighten the screw using the large screw driver to make certain the foot is secure.

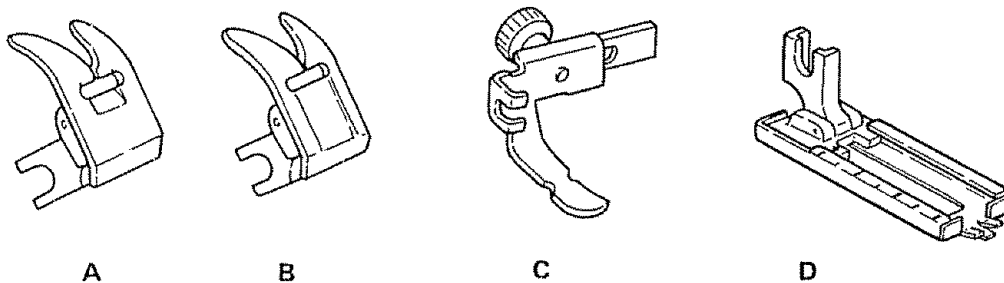

You have been given a variety of presser feet:

- A. Zigzag Foot
- B. Satin Stitch Foot
- C. Zipper Foot
- D. Buttonhole Guide Foot

NOTE:

Additional feet and attachments are available at most large retail stores or through the catalog. Please select attachments for left needle position with low bar.

Starting to Sew

Now that you are familiar with the controls on your machine and with the accessories provided for the machine, you are ready to start to sew with your new Kenmore sewing machine. Below are some good habits to follow each time you sit down to sew:

1. Test the needle it should be straight, properly set and sharp on the point. It should be the correct size for the fabric and thread being used. Do not be afraid to change your needle frequently. Many of the new fabrics made of synthetic blends tend to dull the needles more easily than fabrics made of natural fibers.
2. Before placing the material on the machine, see that the ends of the threads have been drawn about 4 inches to the rear of the machine. Hold on to threads during the sewing of the first 3 or 4 stitches of the seam.
3. Test the machine stitch on a scrap of fabric you plan to use. The fabric should be double thickness. Adjust the machine for the length of stitch and tension suitable to your fabric.
4. Fabric should be placed under the presser foot with the bulk of the material to the left of the needle and the right edge of the material placed on the 5/8" seam marking on the needle plate when making a simple seam.
5. Run the machine at a slow even speed. The more pressure you put on the speed control, the faster the machine will sew.
6. Fasten each seam by back tacking at the beginning and end of the seam.
7. Always finish sewing each seam with the needle at its highest point.
8. Guide the fabric gently with your hand in front of the needle. Never pull or hold the fabric in such a way that the normal feeding is altered.
9. When turning the hand wheel manually, always turn it toward you.

GARMENT CONSTRUCTION STITCHES

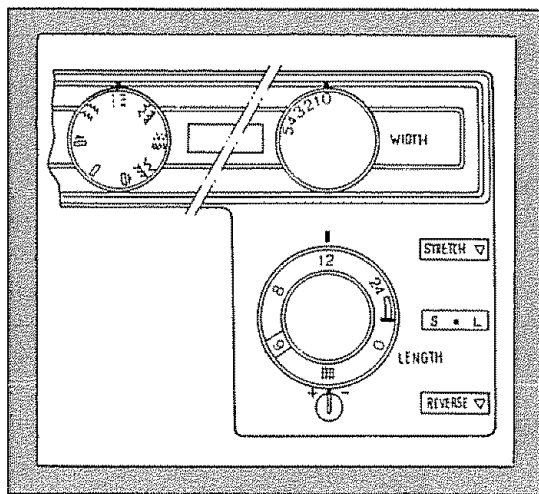

STRAIGHT STITCHING

Set your machine just as shown in the illustration in order to straight stitch. It is important each dial has the following settings:

SETTINGS

Stitch Selector 
 Stitch Width Control 0
 Stitch Length Control 12 to 6
 Stretch Stitch Control Horizontal
 Zigzag Presser Foot

You will find in garment construction that you are doing two types of sewing-temporary and permanent.

1. Temporary stitching-Usually the longest stitch possible and often done on a single layer of fabric. The various types of temporary stitching are:
 - Basting
 - Stay stitching
 - Guide line marking
2. Permanent stitching-This is the actual stitching that holds the garment together. Much of this stitching is visible on the outside of the garment and therefore must be good looking.

The best length stitch to use for medium weight fabrics is 10-12 stitches per inch. This is in the middle range of the Stitch Length Control.

You must remember to lengthen the stitch for heavier fabrics, multiple layers of fabric and thicker seams. Some of these seams are:

- Common two layer seams
- Curved two layer seams
- Top stitched three layer seams
- Top stitched four layer seams

When you have two seams crossing each other with considerable thickness, sew slowly and carefully so the seam will be as strong as possible in this area.

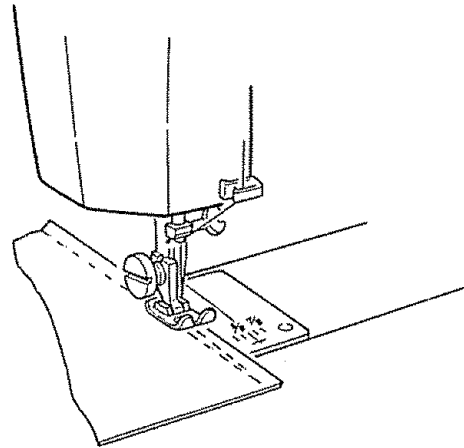

FASTENING A SEAM

Be sure both threads are drawn back under the presser foot. Lower needle into fabric about 1/2 inch from beginning of seam. Turn the reverse stitch control clockwise and stitch in reverse until needle reaches beginning of seam. Release control and complete seam. When you reach the end, turn the control clockwise and sew back over 1/2 inch of completed seam.

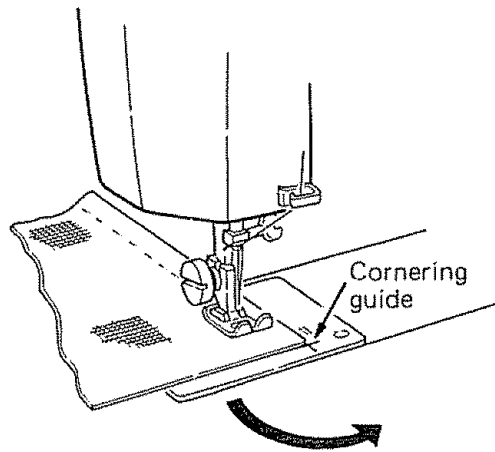

TURNING A SQUARE CORNER

To turn a square corner 5/8" from the fabric edge, stop stitching with the needle tip piercing the fabric, when reaching the cornering guide as shown. Raise the presser foot, turn fabric. New stitching line will align with 5/8" seam guide on side of needle plate. Lower the presser foot and begin stitching in new direction.

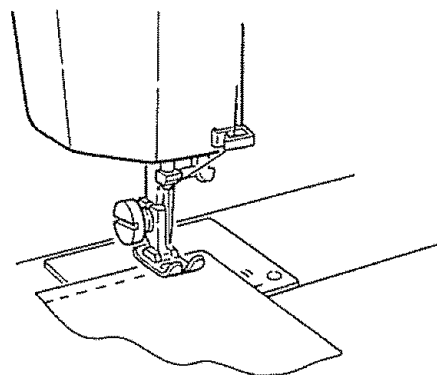

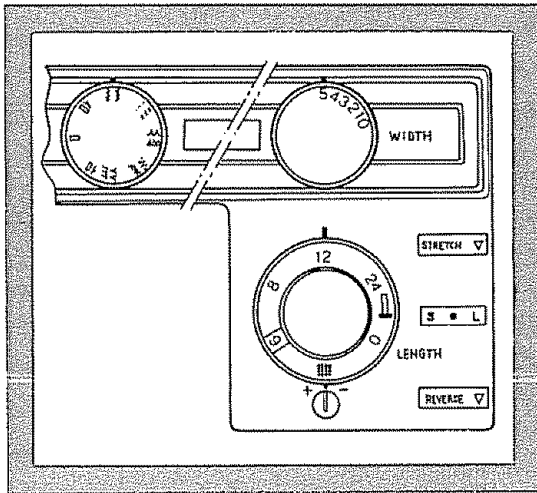

ZIGZAG STITCHING

SETTINGS

Stitch Selector 
 Stitch Width Control 1 to 5
 Stitch Length Control Any Number
 Stretch Stitch Control Horizontal
 Zigzag Presser Foot

This type of stitching greatly expands the use of your machine. This is the feature that enables you to overcast seams, applique and buttonhole. Simply use the settings indicated in the illustration for the simple zigzag. Follow directions given in the following pages for more specific uses.

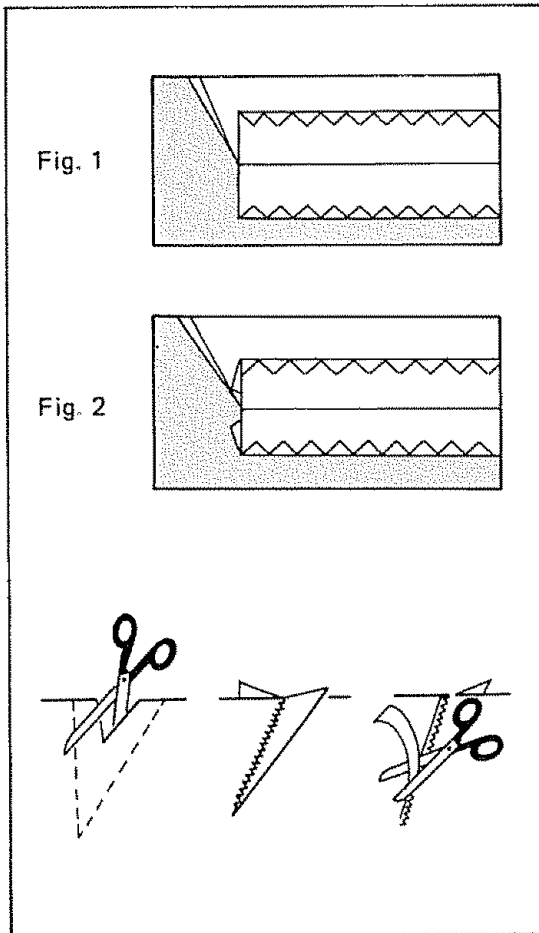

OVERCASTING

This is one of the more frequently used zigzag stitches in garment construction. You may want to overcast along the raw edge of each seam allowance or fold the raw edge toward the garment and stitch.

Fig. 1 shows the raw edge finished.
 Fig. 2 illustrates the folded edge stitched.

Stitch so the needle pierces the fabric just short of the outside edge. Raw or worn edges of older garments can be overcast to prevent further raveling.

INTERFACING DARTS

To reduce bulk of interfacing darts, cut interfacing down center between dart lines. Overlap cut edges, matching dart lines. Zigzag stitch along marking line from point to wide end of dart. Trim both raw edges close to stitching.

STRETCH STITCHING

The stitches shown below are all for use with stretch and knit fabrics. These are special stitches built in to the machine for your quick selection.

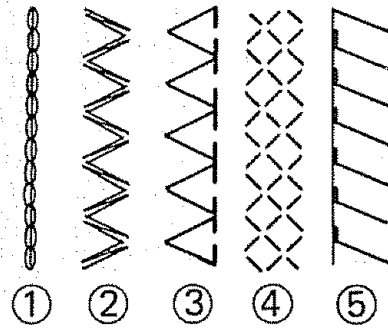

1. Straight Stretch
2. Rickrack Stretch
3. Overcast Stretch
4. Smocking Stretch
5. Serging or Pine Leaf Stretch

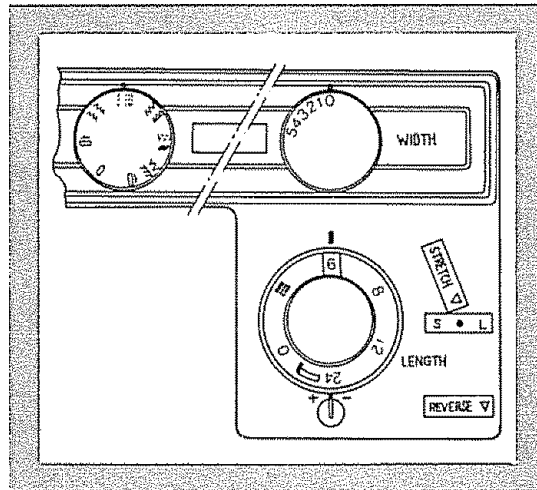

STRAIGHT STRETCH STITCHING



SETTINGS

Stitch Selector	
Stitch Width Control	0
Stitch Length Control	6
Stretch Stitch Control	mark "S" between S and L

Zigzag Presser Foot

Use this stretch stitch with knitted fabric and other fabrics that stretch. Sew as you do with regular straight stitch seaming. The seam may be pressed open as with any regular seam, but will stretch if necessary.

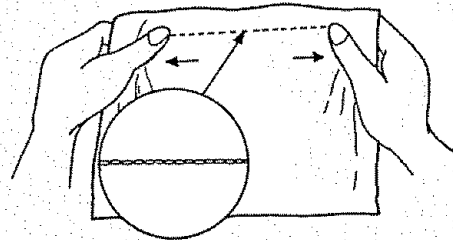

This is also a good stitch to use on curved seams regardless of the type of fabric. Any seam that will receive a great deal of strain when worn should be sewn with the stretch stitch. Use in children's shorts and slacks as well as adult sports clothes.

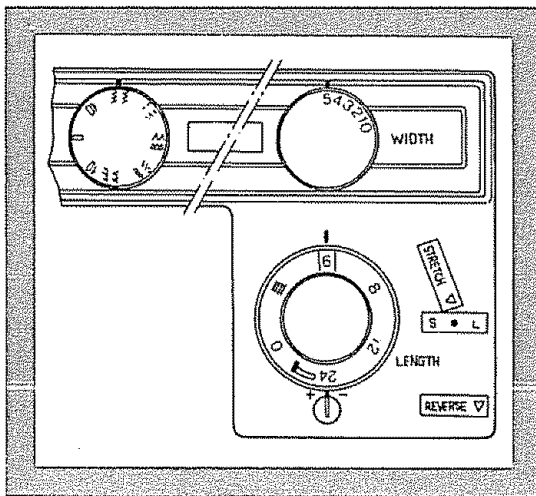

RICK-RACK STRETCH STITCHING



SETTINGS

Stitch Selector	...	
Stitch Width Control	...	2 to 5
Stitch Length Control	...	6
Stretch Stitch Control	...	mark "o"
		between S and L

Zigzag Presser Foot

Sew on stretch fabrics in any area that you might use a zigzag stitch. This stitch can be used as a decorative top stitch as well.

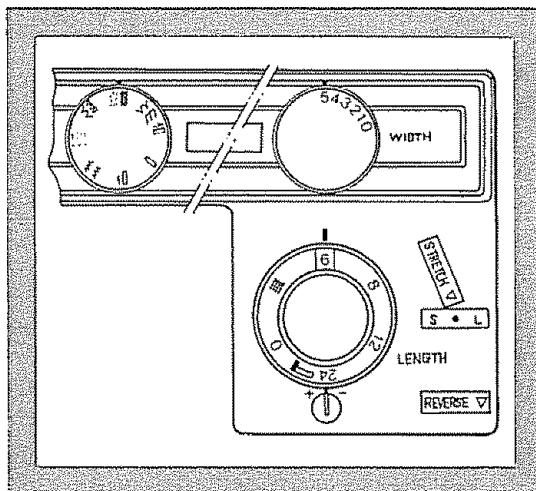

SMOCKING STRETCH STITCHING



SETTINGS

Step 1.	Make a straight line of gathers across the fabric that you wish to smock.	
Step 2. Settings		
Stitch Selector	...	
Stitch Width Control	...	5
Stitch Length Control	...	6
Stretch Stitch Control	...	mark "o"
		between S and L

Zigzag Presser Foot

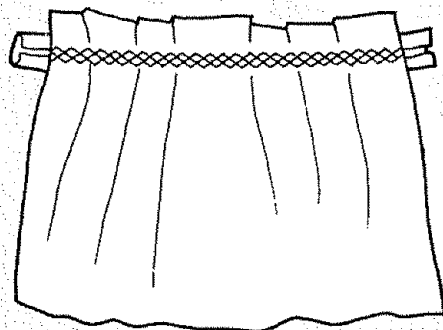

With a narrow strip of fabric directly under the line of gathering, stitch over the gathers. The design will be a series of small diamonds.

When smocking a garment, the stitching should be done before the piece is sewn into the garment.

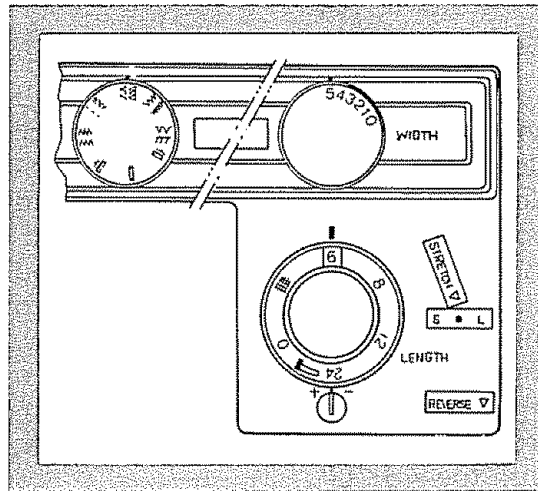

OVERCAST STRETCH STITCHING



SETTINGS

Stitch Selector	
Stitch Width Control	5
Stitch Length Control	6
Stretch Stitch Control	mark "S" between S and L

Zigzag Presser Foot

This is the same type of stitch used by the garment industry in making sportswear. It is used for seams of 3/8" to 1/4". The seam is formed and finished in one operation. It must be used when you are making swimwear, ski pants and other garments that require stretch.

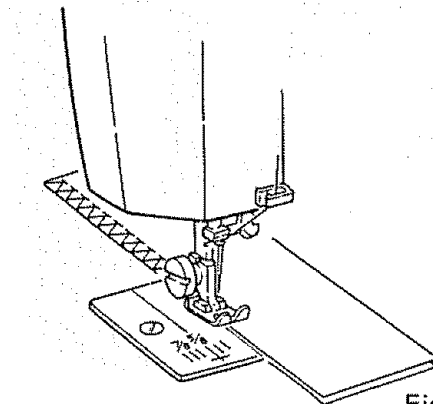
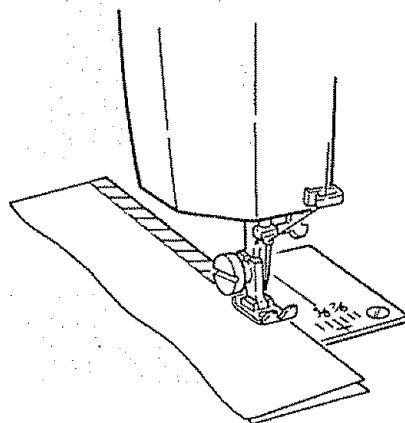

Fig. 1

Fig. 1 shows the raw edge finished.

Stitch so the needle pierces the fabric just short of the outside edge.

Raw or worn edges of older garments can be overcast to prevent further raveling.



SERGING OR PINE LEAF STRETCH STITCHING

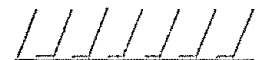

SETTINGS

Stitch Selector	
Stitch Width Control	5
Stitch Length Control	6
Stretch Stitch Control	mark "S" between S and L

Zigzag Presser foot

The serging or pine leaf stretch stitch is equally useful with woven and knitted fabrics. This stitch can be used in making elastic swimwear, as well as overcasting a neat edge on the seams.

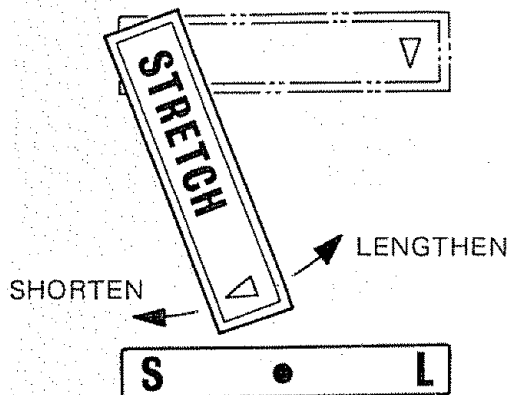

ADJUSTING STRETCH STITCH BALANCE

In stretch stitch sewing, Stretch Stitch Control should be in the detent position between S and L (black dotted position) for most materials. Depending upon the type of fabric used, you may need to adjust this control to match forward stitches of stretch sewing with reverse motion stitches. To shorten stretch stitches, turn the control slightly toward "S". To lengthen, turn toward "L".

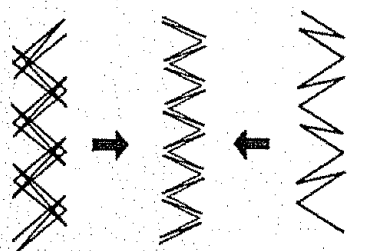

Rickrack Stretch

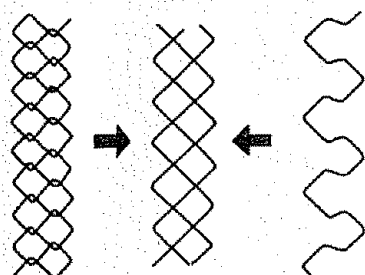

Smocking Stretch

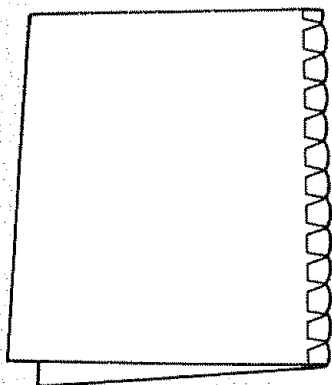

SHELL STITCHING



This stitch used on the edge of nylon tricot makes a lovely Shell finish. Use the following settings:

SETTINGS

Stitch Selector 
 Stitch Width Control 5
 Stitch Length Control 18
 Stretch Stitch Control Horizontal
 Zigzag Presser Foot

When sewing this stitch, allow needle to just clear the right edge of the fabric when it zig zags.

SPECIAL FINISHING STITCHES

After the basic construction of your garment is finished, there are still many finishing touches to be done. To aid your completion of your garment, the Kenmore has been designed to do the following tasks that formerly had to be done by hand.

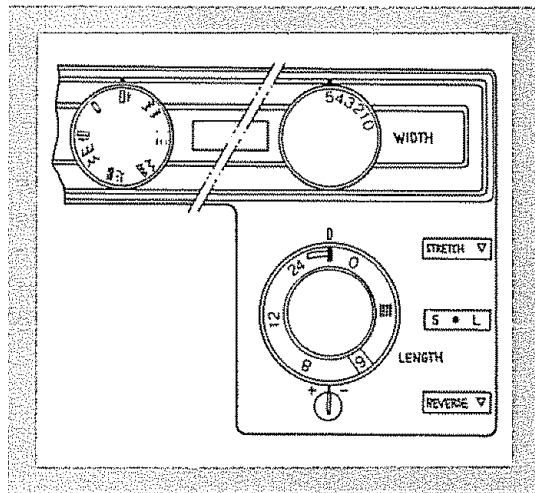

BUTTONHOLE MAKING

SETTINGS

Stitch Selector → → →
 Stitch Width Control 5
 Stitch Length Control Green Zone
 Stretch stitch Control Horizontal
 Buttonhole Guide Foot

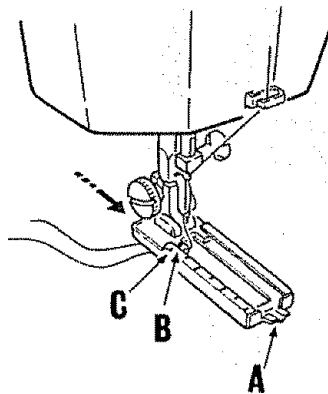

1. Carefully mark the buttonhole length on your garment. Place the fabric with the buttonhole marked under the buttonhole foot. Pull the guide foot (A) all the way forward so that the index mark (B) is aligned with the graduation (C), with thread to rear. (Reproduction of the identical size buttonholes is facilitated with the aid of the graduations on the left side of the buttonhole guide foot. These graduations are 1/5" apart. Graduations act as reference mark.)

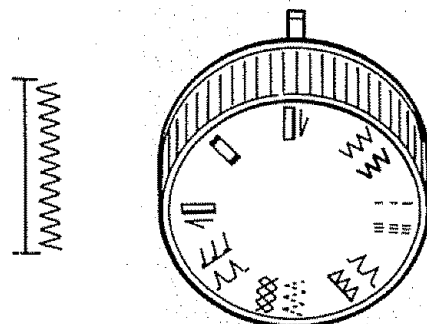

Step 1

2. Set stitch selector at . Stitch forward until you approach the bottom marking of the buttonhole. Stop sewing at the right stitch and raise the needle to its highest position by turning hand-wheel toward you manually.

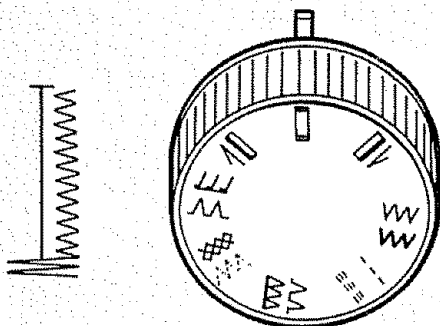

Step 2

3. Set stitch selector at  and bartack several times at the bottom mark of the buttonhole. Stop sewing at the left stitch. Raise needle to its highest position by turning handwheel toward you.

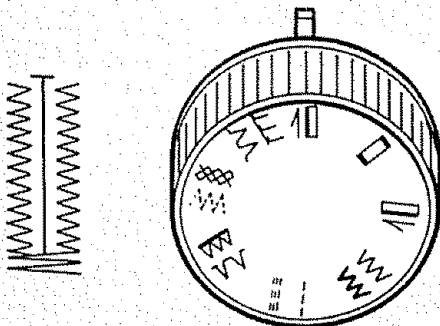

Step 3

4. Set stitch selector at  and sew the other side of the buttonhole until you approach the top marking of the buttonhole. Stop sewing at the left stitch. Raise the needle to its highest position.

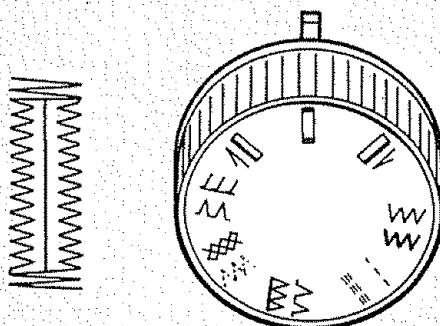

Step 4

5. Set stitch selector at  again and bartack several times to finish the buttonhole.

Always make a practice buttonhole on a scrap of fabric you plan to use. Try the buttonhole with the button you will use.

Always use an interfacing in area of garment where buttonholes are placed. Tissue paper or regular interfacing can be used. Tear paper away after stitching, if it is used.

For heavier weight fabrics, loosen your top tension slightly.

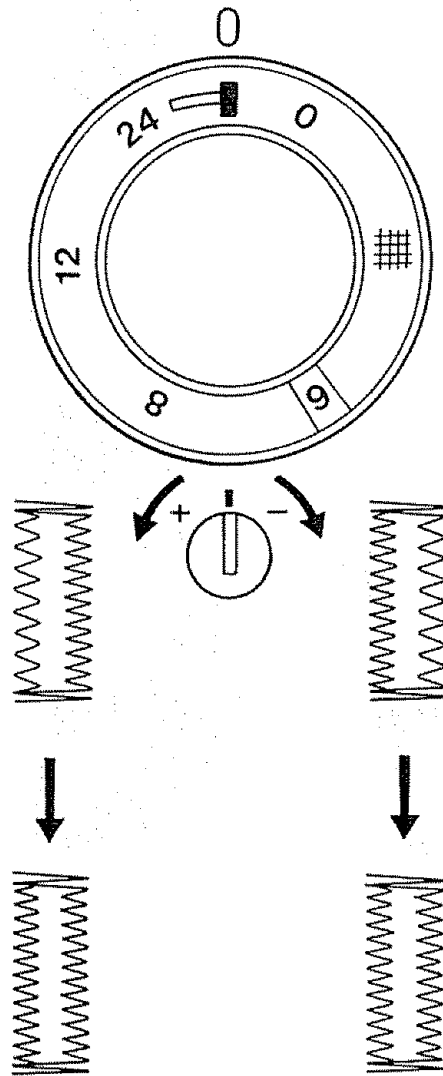

ADJUSTING BUTTONHOLE STITCH BALANCE

If the right side of stitching does not exactly match the left side of stitching, adjust the stitchings by buttonhole-stitch adjuster.

When the left side of buttonhole is coarse, turn the adjuster toward the plus "+" direction.

When the right side is coarse, turn the adjuster toward the minus "-" direction.

After you finish buttonhole sewing, put the adjuster back to the original position.

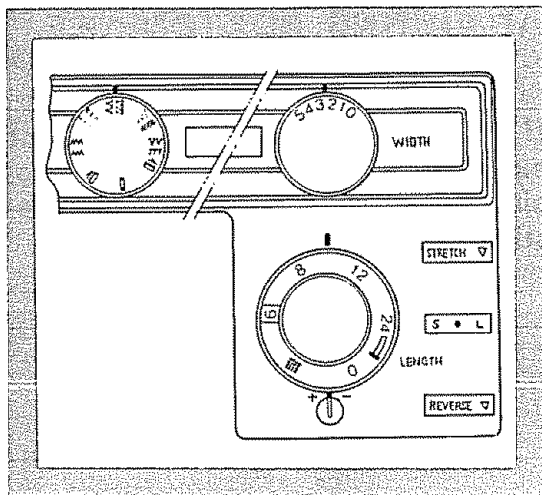

BLIND HEMMING

SETTINGS

Stitch Selector 
 Stitch Width Control 2 to 3
 Stitch Length Control 12 to 8
 Stretch Stitch Control Horizontal
 Zigzag foot or edgestitcher if available

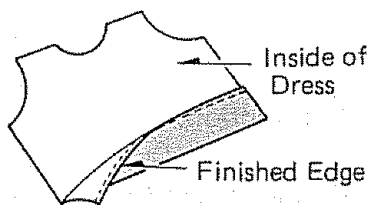

Fig. 1

1. Finish edge of hem anyway you desire. Turn up hem appropriate width. (Fig. 1)

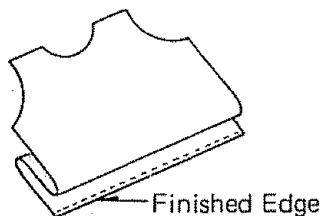

Fig. 2

2. Fold garment away from hem leaving 1/8" of hem edge extending. (Fig. 2)

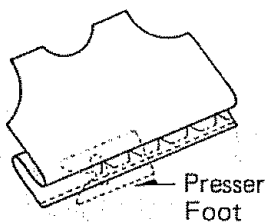

Fig. 3

3. Place garment under presser foot in such a manner that straight stitches will be sewn on extended edge. The zigzag stitch should just catch the fold of the garment. (Fig. 3)

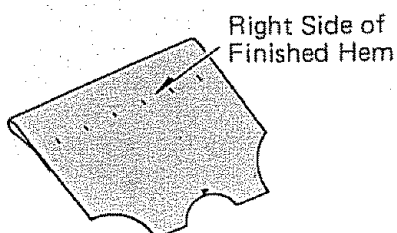
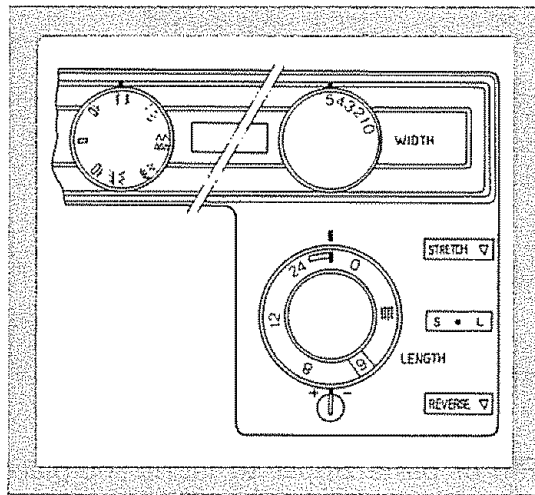

Fig. 4

4. Press both sides of the finished hem. The right side of the garment will show only the blind stitches. (Fig. 4)



SATIN STITCHING

SETTINGS

Stitch Selector VW
 Stitch Width Control VW 2 to 5
 Stitch Length Control VW Green Zone
 Stretch Stitch Control VW Horizontal
 Satin Stitch Foot

Closely spaced zigzag stitches are called satin stitches. This is an attractive stitch used for appliqueing, monogramming, buttonhole making.

Whenever you are using this stitch, it is well to remember to loosen the tension of the top thread slightly. The wider the stitch you make, the looser the tension should be.

If you are stitching on a very soft fabric, use a backing of tissue paper or interfacing for a well formed stitch. Puckering of the material will be eliminated and the bobbin thread will not be visible on the right side of the fabric.

As with all special stitches, it is best to make a sample design on your fabric before starting the design on the garment.

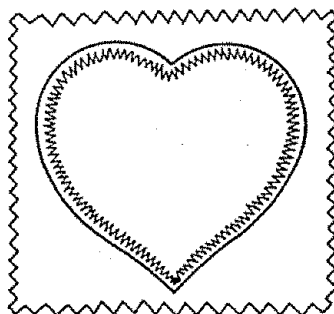

APPLIQUEING

SETTINGS

Same as with Satin Stitching

Select an applique design to be applied to your garment and baste it in place. Satin stitch around the raw edge of the applique completely covering the edge. You may want to do this with a contrasting color of thread or same color.

ZIPPER APPLICATION

SETTINGS

Stitch Selector 1 #
Stitch Width Control 0
Stitch Length Control . . . 12
Stretch Stitch Control . . . Horizontal
Zipper Foot

REGULAR ZIPPER

Pin or baste zipper to fabric and place the work in position under the presser foot. Loosen the zipper foot adjusting screw to set the foot on the left side of the needle, and sew the left side zipper as shown. (Fig. 1) To sew the right-side zipper, loosen the screw and bring the foot to the right side of the needle.

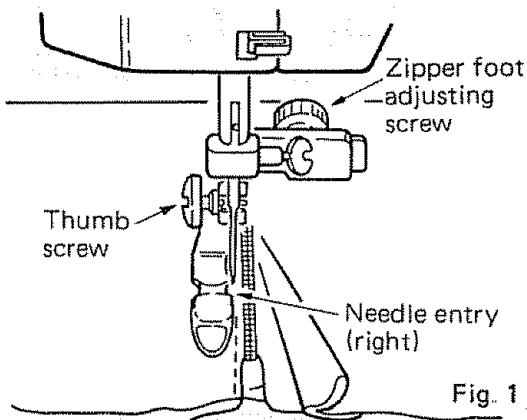

INVISIBLE ZIPPER

Adjust the foot so the needle is sewing through the center hole of the foot and one groove of the foot is riding on the teeth of the zipper. See Fig. 2. Follow the zipper manufacturer's instructions.

After zipper has been inserted, finish sewing seam by shifting foot to side position sewing through side notch.

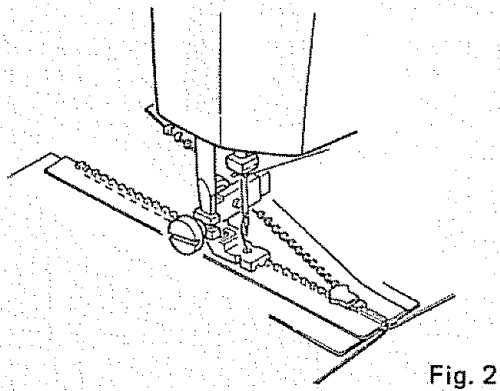

CORDING

Foot can also be used to make cording for slipcovers etc. Cover a cord with a strip of bias fabric and sew as shown in Fig. 3.

NOTE:

Use "Low Bar Sewing Machine ZIPPER FOOT" (6757) for "invisible zipper" and "cording", which can be obtained at any stores of Sears Roebuck and Co.

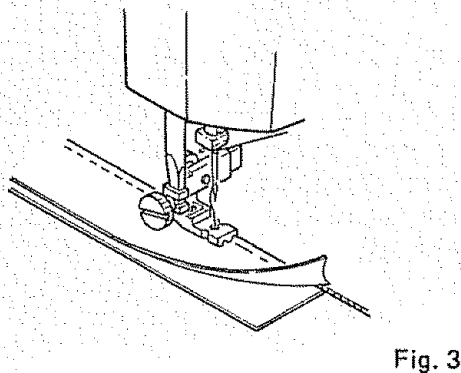

MENDING

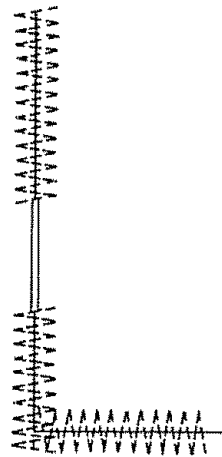

SETTINGS

Stitch Selector 
 Stitch Width Control 5
 Stitch Length Control White Zone
 Stretch Stitch Control Horizontal
 Zigzag Presser Foot

To repair a straight or three-cornered tear, position the tear under the needle in such a way that the stitching catches both sides of the tear. When mending a three-cornered tear, stitch from each end to the center. It is well to use a piece of fabric under the tear for reinforcement.

DARNING

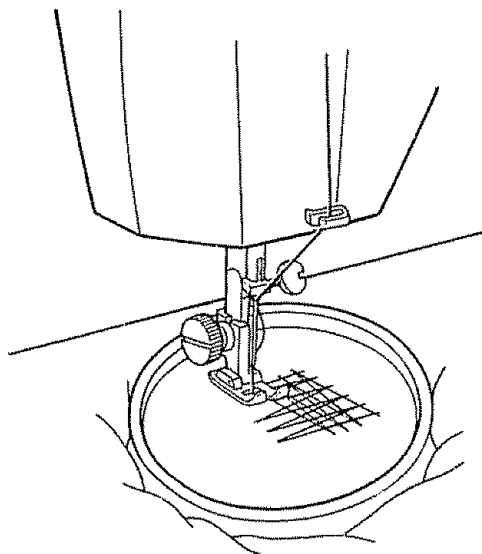

SETTINGS

Stitch Selector 
 Stitch Width Control 0
 Stitch Length Control 8 to 10
 Stretch Stitch Control Horizontal
 Presser Foot Pressure 0
 Zig Zag Foot

Stretch fabric between embroidery hoops with hole centered. Lower presser bar and sew at a slow speed moving fabric back and forth with a steady rhythm to cover darning area. When it is covered, turn fabric 1/4 a turn and sew layer of stitching across first layer.

If fabric is thin or badly damaged in hole area, you may want to put a separate piece under the hole for reinforcement.

BUTTON SEWING

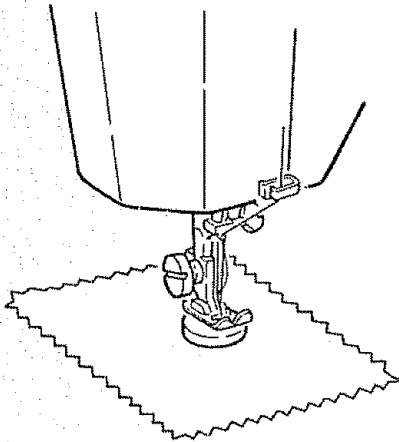

SETTINGS

Stitch Selector	⌘
Stitch Width Control	Must be adjusted
Stitch Length Control . . .	⌘
Stretch Stitch Control . . .	Horizontal Zigzag Presser Foot

1. Align two holes of button with slot of presser foot and lower foot to hold the button securely.
2. Turn hand wheel manually until needle point is just above button.
3. Adjust stitch width control so needle will enter left hole of the button.
4. Turn hand wheel again by hand so needle enters second hole. Readjust stitch width if necessary. Stitch a number of times.
5. Finish sewing with an extra two inches of thread remaining. Draw these threads to reverse side of garment and tie.

BAR TACKING

SETTINGS

Stitch Selector	⌘
Stitch Width Control	1 to 5
Stitch Length Control . . .	Green Zone
Stretch Stitch Control . . .	Horizontal Zigzag Presser Foot

This stitch is similar to a very short satin stitch and is used to reinforce points of strain such as corners of pockets and straps on lingerie.

Sew 4 to 6 zigzag stitches.

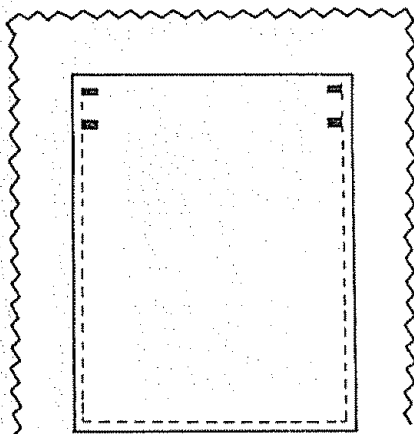

FREE-ARM SEWING

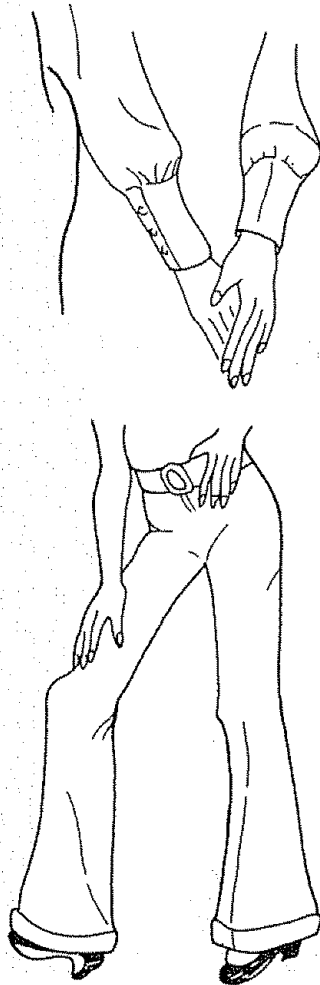
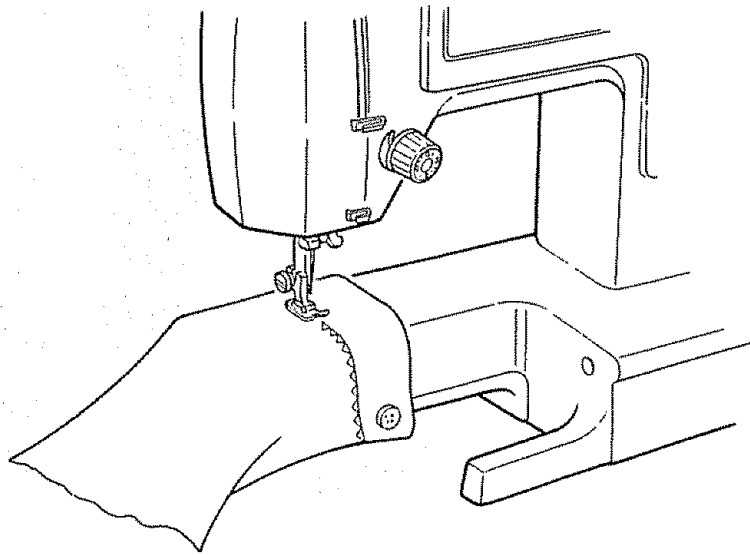

This sewing machine can be used like a flat bed machine, but easily converts to free arm machine by removing the extension table.

The free arm enables you to sew tubular types of pieces more easily. Just slip the sleeve or pants leg on the free arm as shown above.

You will find many uses for this free arm feature such as:

1. Mend elbows and knees of garments more easily.
2. Sew in sleeves more easily. This is especially true when sewing smaller garments.
3. Applique, embroider or hem around edges of cuffs or pants legs.
4. Sewing in elastic casings in skirts or pants at the waistline.

Checking Performance Problems WHAT TO DO

PROBLEM	PROBABLE CAUSE	CORRECTION
Irregular Stitches	<p>Incorrect size needle. Improper threading. Loose upper thread tension. Pulling fabric. Light pressure on presser foot. Loose presser foot. Unevenly wound bobbin. Nicks or burrs on shuttle. Nicks or burrs at hole of needle plate.</p>	<p>Choose correct size needle for thread and fabric. Rethread machine. Tighten upper thread tension. Do not pull fabric; guide it gently. Increase pressure on presser foot. Reset presser foot. Rewind bobbin. Replace shuttle, or polish off burrs completely. Replace needle plate, or polish off burrs completely.</p>
Breaking Needle	<p>Pulling fabric. Incorrect size needle. Incorrect setting of needle. Loose presser foot.</p>	<p>Do not pull fabric; guide it gently. Choose correct size needle for thread and fabric. Reset needle. Reset presser foot.</p>
Bunching of Thread	<p>Upper and lower threads not drawn back under presser foot before starting seam.</p>	<p>When starting a seam be sure to draw both threads under and back of presser foot about 4" and hold until a few stitches are formed.</p>
Puckering	<p>Incorrect thread tension(s). Light pressure on presser foot. Using two different sizes or kinds of thread. Bent or blunt needle. Loose presser foot. Fabric too sheer or too soft.</p>	<p>Reset thread tension(s). Increase pressure on presser foot. Upper thread and bobbin thread should be same size and kind. Insert new needle. Reset presser foot. Use underlay of tissue paper.</p>

PROBLEM	PROBABLE CAUSE	CORRECTION
Skipping Stitches	<p>Incorrect size needle. Certain knits and synthetics. Bent or blunt needle. Incorrect setting of needle. Tight upper thread tension. Light pressure on presser foot.</p>	<p>Choose correct size needle for thread and fabric. Use "Q NEEDLE"™ Insert new needle. Reset needle. Loosen upper thread tension. Increase pressure on presser foot.</p>
Breaking Upper Thread	<p>Starting to stitch too fast. Improper threading. Tight upper thread tension. Incorrect size needle. Sharp eye in needle. Nicks or burrs on shuttle. Nicks or burrs at hole of needle plate.</p>	<p>Start to stitch at a medium speed. Rethread machine. Loosen upper thread tension. Choose correct size needle for thread and fabric. Insert new needle. Replace shuttle, or polish off burrs completely. Replace needle plate, or polish off burrs completely.</p>
Breaking Bobbin Thread	<p>Improper bobbin case threading. Tight bobbin thread tension. Lint in bobbin case or shuttle.</p>	<p>Check bobbin case threading. Loosen bobbin thread tension. Clean bobbin case and shuttle.</p>
Fabric not Moving	<p>Stitch length control sets at darning position (###). Light pressure on presser foot. Thread knotted under fabric.</p>	<p>Stitch length between 6 to 24. Increase pressure on presser foot. Place both threads back under presser foot before beginning to stitch.</p>
Machine Jamming Knocking Noise	<p>Thread caught in shuttle.</p>	<p>Disassemble and clean shuttle.</p>

Caring for the Machine

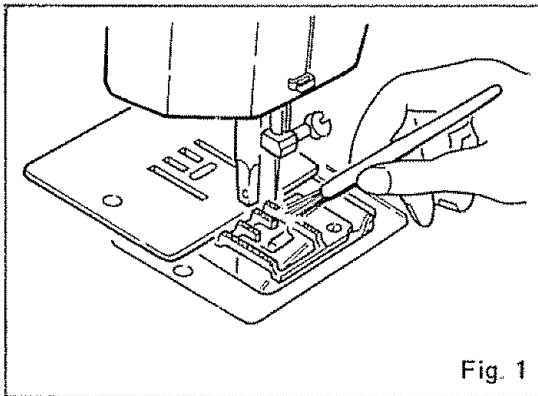

Fig. 1

CLEANING AND OILING

Fig. 1 Cleaning the feed dogs with a brush.

To insure the best possible operation of your machine, it is necessary to keep the essential parts clean at all times. Using a small brush, remove the lint that accumulates in the shuttle area and around the feed dogs.

Fig. 2 Parts of the Shuttle Assembly

To Clean the Shuttle Area:

1. This area must be kept free of dust, lint and occasional tangled thread. Raise the needle bar to its highest point and remove the bobbin case.
2. Push levers of shuttle race aside and lift shuttle race cover and shuttle out.
3. Clean the shuttle race with small brush.
4. Put a drop of oil on the center pin of the shuttle and shuttle race. (see arrows)

To Replace Shuttle Assembly:

1. Position shuttle race as illustrated so that race is forming half moon on the left side of the machine.
2. Hold shuttle by center pin and position shuttle so as to form a half moon on the right side. Pointed hook will be on the bottom.
3. Place shuttle race cover into place over shuttle assembly.
4. Snap the levers into position.

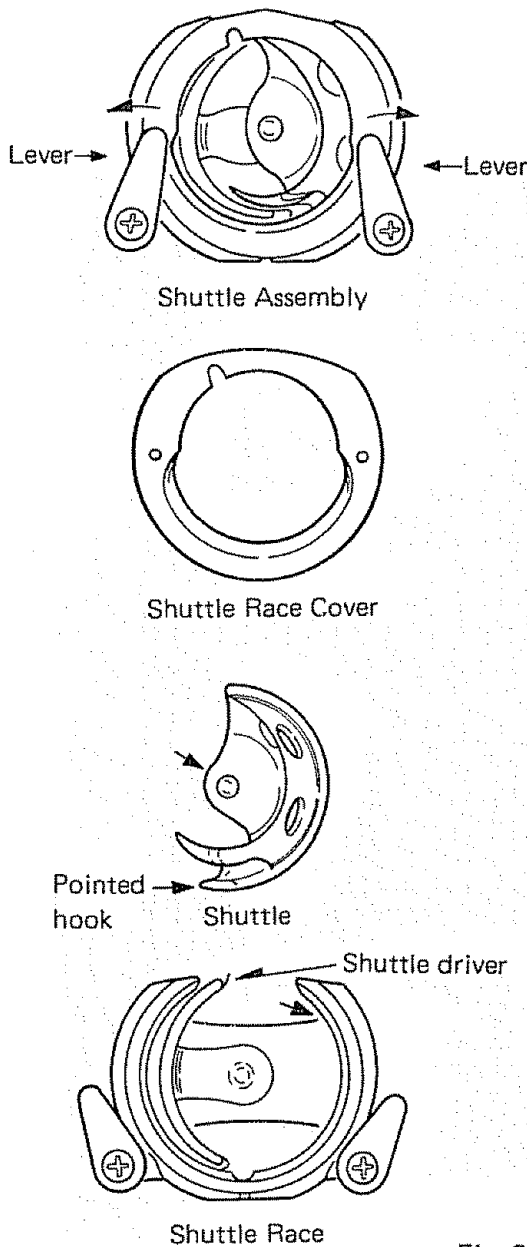
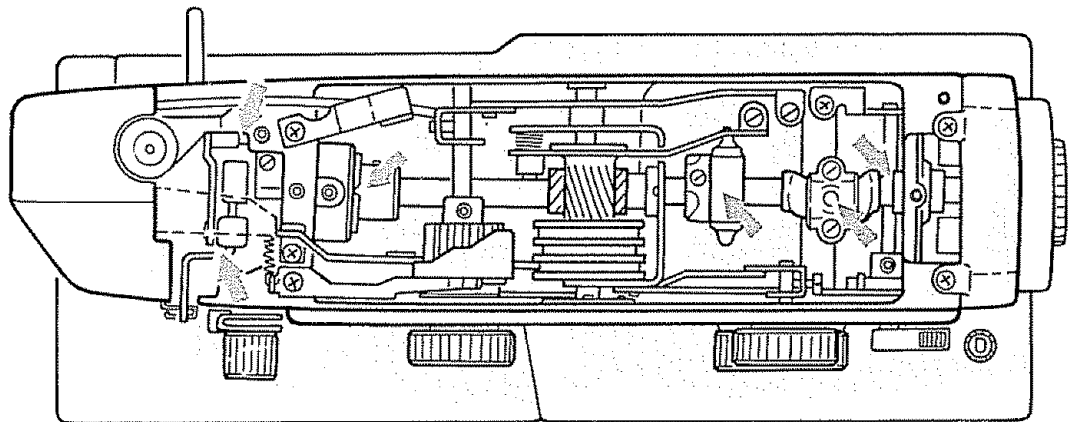

Fig. 2

OILING UNDER ARM COVER PLATE

Remove arm cover plate to oil points indicated in top of machine head. To remove cover plate, loosen up two top screws and lift the cover plate as illustrated below.



OILING UNDERSIDE

Tilt machine head back and remove bottom covers to oil points indicated on underside of machine. To remove bottom covers, remove screws (A), (B), (C), and (D) as shown below.

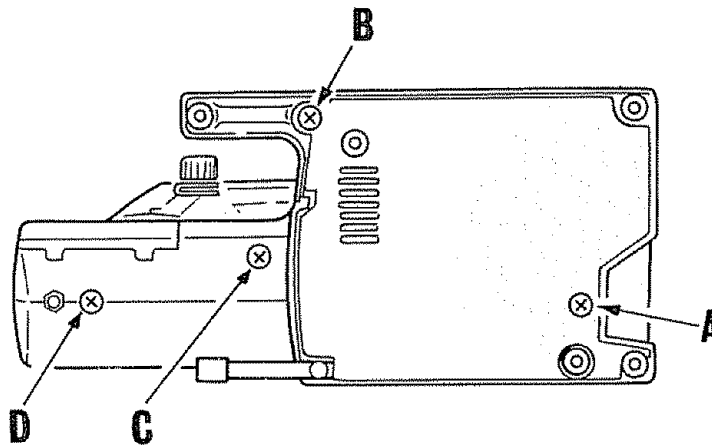
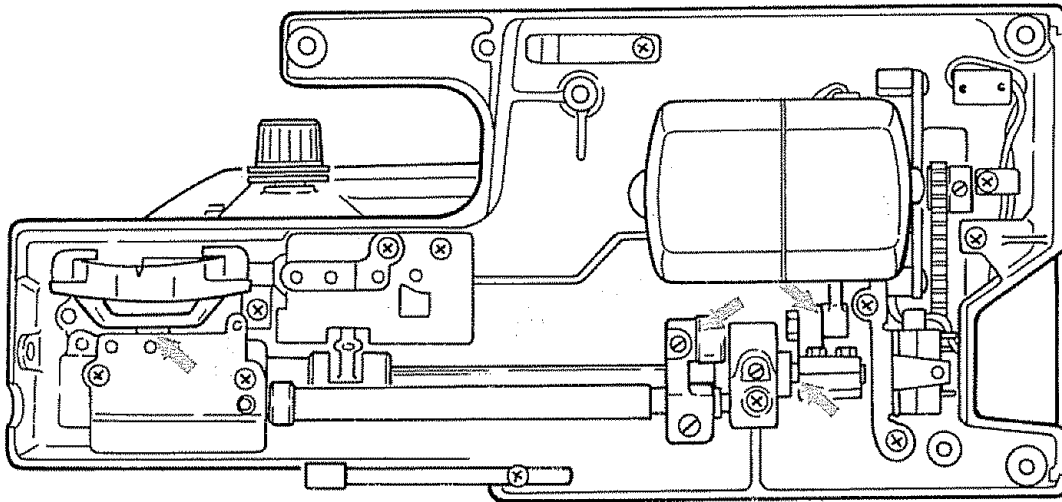

OILING IN FACE COVER PLATE

Open face cover plate and oil points in illustration.

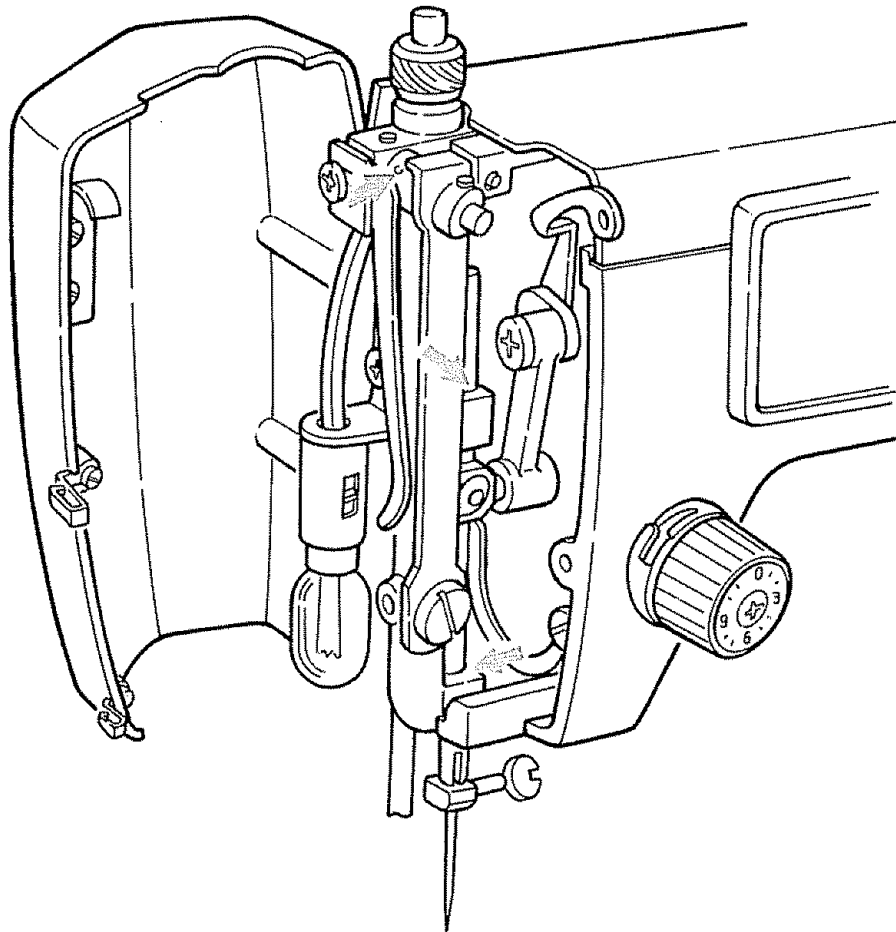

PARTS LIST

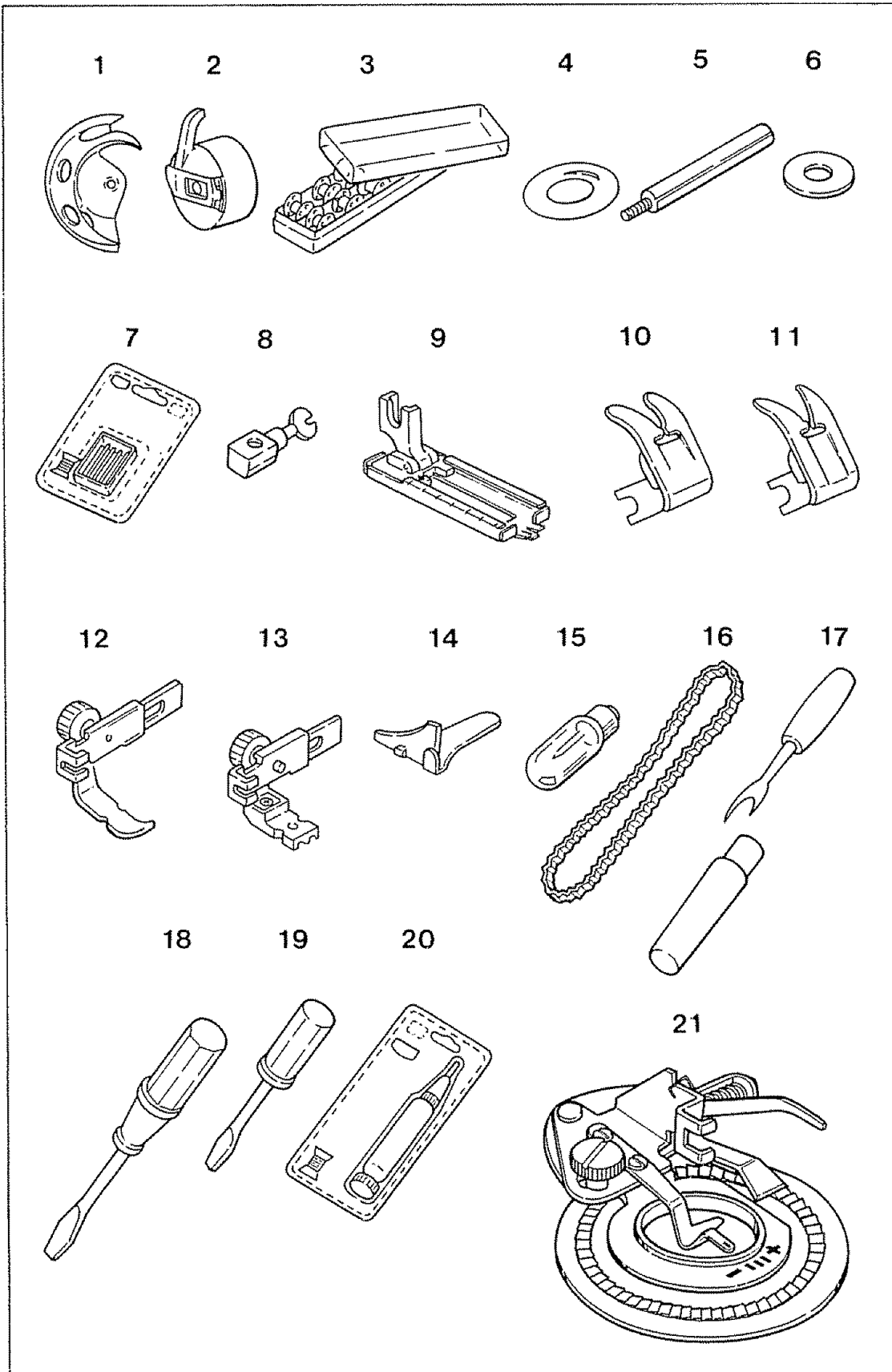

PARTS LIST

All parts listed herein may be ordered from any Sears store or service center.

WHEN ORDERING REPAIR PARTS, ALWAYS GIVE THE FOLLOWING INFORMATION:

- | | |
|-----------------|---------------------|
| 1. PART NUMBER | 2. PART DESCRIPTION |
| 3. MODEL NUMBER | 4. NAME OF ITEM |

If the parts you need are not stocked locally, your order will be electronically transmitted to a Sears Repair Parts Distribution Center for expedited handling.

Ref. No.	Part No.	Description
1	47	Shuttle
2	6510	Bobbin case
3	*6862	Bobbin box with 10 bobbins
4	1939	Bobbin winder rubber ring
5	8286	Thread spool pin
6	2273	Nylon disc
7	6550	No. 9 Single needles (BRN)
	6551	No. 11 Single needles (ORG)
	6552	No. 14 Single needles (RED)
	6553	No. 16 Single needles (PUR)
	6554	No. 18 Single needles (GRN)
	*6746	"Q NEEDLES"™
8	36353	Needle clamp with screw
9.	648801005	Buttonhole guide foot
10	40390	Standard zigzag foot
11	6870	Satin stitch foot
12	593401008	Zipper foot
13	*6757	Zipper foot
14	*6864	Needle threader
15	6797	Light bulb
	40164	Motor belt
16	33379	Motor belt
17	6830	Buttonhole opener
18	41670	Large screw driver
19	41669	Small screw driver
20	*6889	Oil and lint brush
21	*6530	Flower stitch attachment

*These items are not furnished with the machine, but may be ordered per instructions above.

WARRANTY

FULL 25 - YEAR WARRANTY ON SEWING MACHINE HEAD

For 25 years from the date of purchase, Sears will, free of charge, repair defects in material or workmanship which appear in the sewing machine head.

FULL TWO YEAR WARRANTY ON ELECTRICAL EQUIPMENT OF SEWING MACHINE

For two years from the date of purchase, Sears will, free of charge, repair defects in material or workmanship which appear in the electrical equipment of the sewing machine, including motor, wiring, switch and speed control.

FULL 90 - DAY WARRANTY ON ALL PARTS AND MECHANICAL ADJUSTMENTS

For 90 days from the date of purchase, Sears will, free of charge, replace any parts and provide mechanical service necessary for proper operation of the sewing machine, except for normal maintenance.

To obtain warranty service described above, SIMPLY CONTACT THE NEAREST SEARS STORE OR SERVICE CENTER IN THE UNITED STATES. This warranty applies only while this product is in use in the United States.

This warranty gives you specific legal rights, and you may also have other rights which vary from state to state.

SEARS, ROEBUCK AND CO., Dept. 698/731A, Sears Tower, Chicago, IL 60684

SEWING MACHINE

Now that you have purchased your Sewing Machine, should a need ever exist for repair parts or service, simply contact any Sears Service Center and most Sears, Roebuck and Co.. Be sure to provide all pertinent facts when you call or visit.

The model number of your Sewing Machine will be shown on your nomenclature plate on the back of your Sewing Machine. See Section 1, page 3 for location.

WHEN ORDERING REPAIR PARTS, ALWAYS GIVE THE FOLLOWING INFORMATION:

***MODEL NUMBER *NAME OF ITEM *PART DESCRIPTION**

If the parts you need are not stocked locally, your order will be electronically transmitted to a Sears Repair Parts Distribution Center for handling.

SEARS, ROEBUCK AND CO., Chicago, IL 60684 U.S.A.