

Installation Instructions

Built-In Dishwasher

If you have questions, call 800.GE.CARES (800.432.2737) or visit our website at: www.ge.com



BEFORE YOU BEGIN

Read these instructions completely and carefully.

IMPORTANT – Observe all governing codes and ordinances.

- **Note to Installer** – Be sure to leave these instructions for the consumer and local inspector's use.
- **Note to Consumer** – Keep these instructions with your Owner's Manual for future reference.
- **Skill Level** – Installation of this dishwasher requires basic mechanical, electrical and plumbing skills. **Proper installation is the responsibility of the installer. Product failure due to improper installation is not covered under the GE Appliance Warranty. See warranty information.**
- **Completion Time** – **1 to 3 Hours.** New installations require more time than replacement installations.

IMPORTANT – The dishwasher **MUST** be installed to allow for future removal from the enclosure if service is required.

If you received a damaged dishwasher, you should immediately contact your dealer or builder.

Optional Accessories – See the Owner's Manual for available custom panel kits.

FOR YOUR SAFETY

Read and observe all **CAUTIONS** and **WARNINGS** shown throughout these instructions. While performing installations described in this booklet, gloves and safety glasses should be worn.

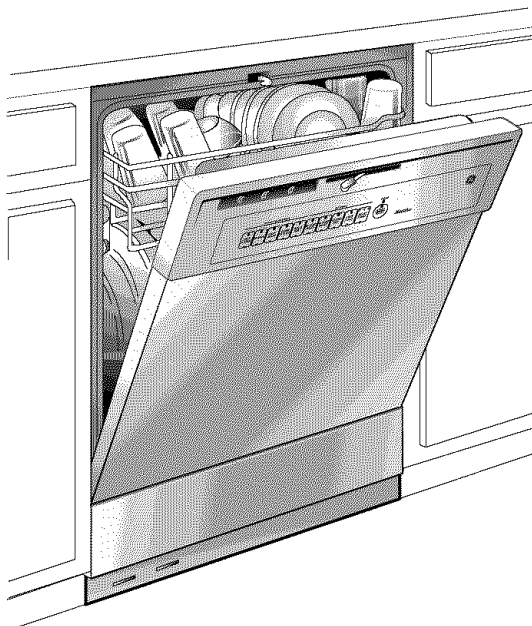

**READ CAREFULLY.
KEEP THESE INSTRUCTIONS.**

PARTS SUPPLIED IN INSTALLATION PACKAGE:

- Two 8-18 x 5/8" Phillips head wood screws
- Junction box cover and #10 hex head screw
- Drain hose (78" long) and hose clamp
- Cord protector (Power Cord Models Only)
- Conversion leads (Power Cord Models Only)
- Literature, product samples, and/or coupons

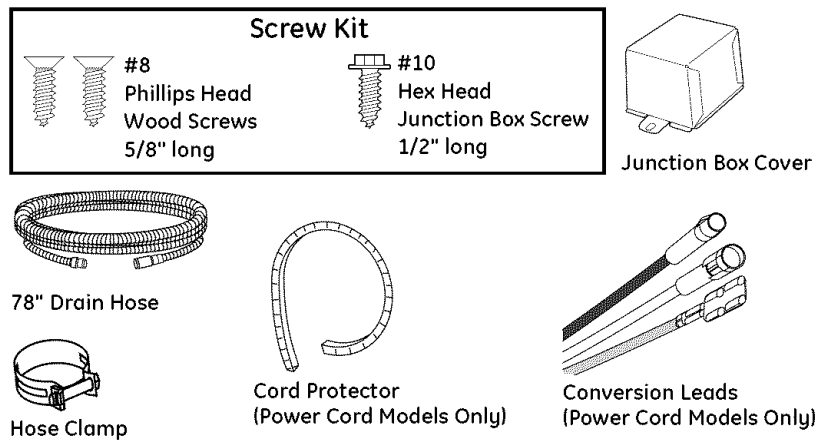

MATERIALS YOU WILL NEED:

- WX09X70910 power cord if applicable to your installation
- UL Listed wire nuts (3)
- Thread seal tape
- 90° elbow, ferrule and compression nut – (3/8" NPT external thread on one end and opposite end sized to fit water supply)
- GPF65 Side-mount bracket kit for use with granite countertops

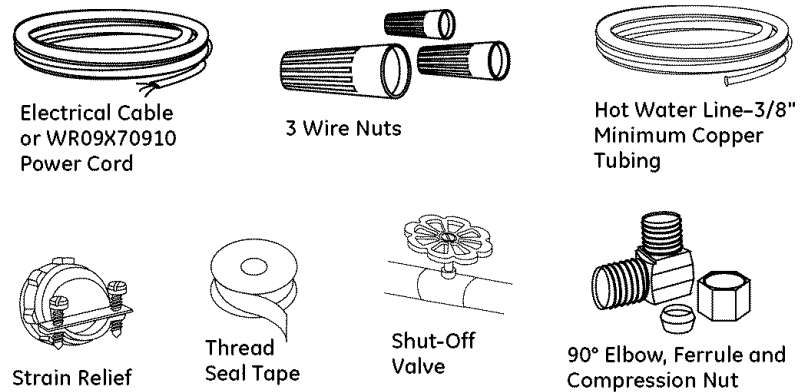

FOR NEW INSTALLATIONS:

- Electrical cable
- Water line – 3/8" minimum copper tubing
- Strain relief for electrical connection
- Hand shut-off valve (recommended)
- Air gap for drain hose, if required
- Waste tee for house plumbing, if applicable
- GPF10S drain hose (10' long), if needed
- Screw type hose clamps

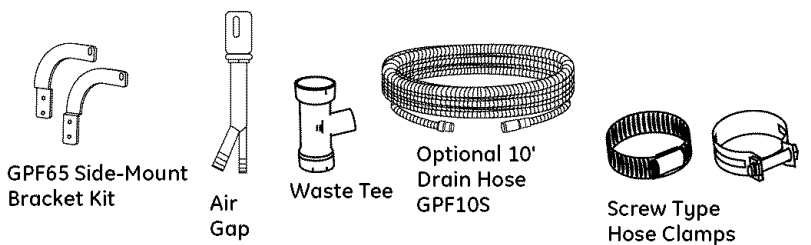

TOOLS YOU WILL NEED:

- Safety glasses
- 1/4" and 5/16" nutdrivers
- Flashlight
- Gloves
- Adjustable wrench (6")
- Phillips head screwdriver
- Measuring tape
- Level
- Carpenters square
- Bucket to catch water when flushing water line
- Tubing cutter
- 15/16" socket wrench

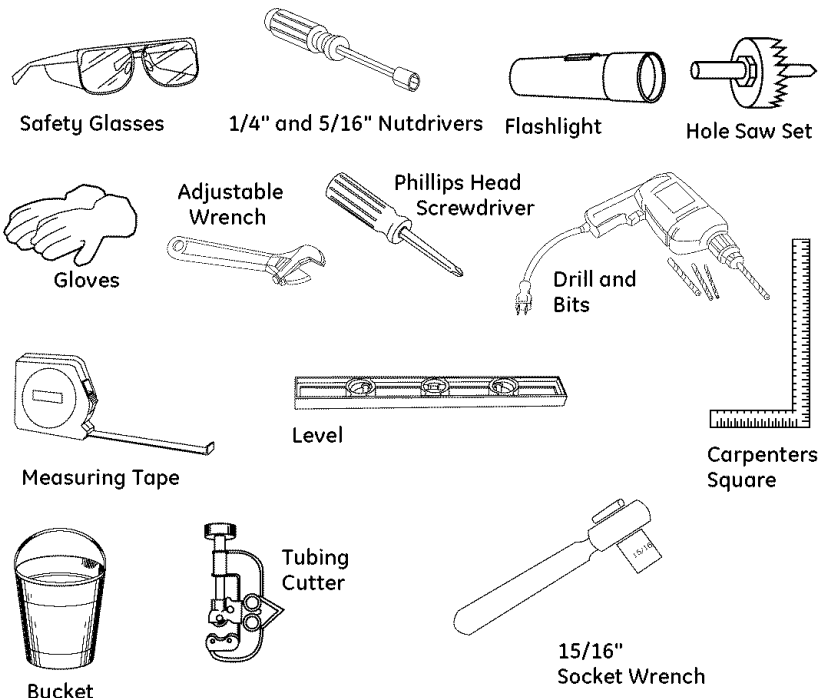

FOR NEW INSTALLATIONS:

- Hole saw set
- Drill and appropriate bits

Installation Preparation–Enclosure

PREPARE DISHWASHER ENCLOSURE



WARNING
To reduce the risk of shock, fire, or injury to persons, the installer must ensure that the dishwasher is completely enclosed at the time of installation.

- The rough cabinet opening must have a minimum width and depth of 24" and height of $34\text{-}1/2" \pm 1/4"$ from the floor to the underside of the countertop.
- The back wall should be free of pipes or wires.
- Adjacent cabinets should be square and plumb to ensure a good fit. Refer to Figure A
- For a corner installation, allow 2" minimum clearance between the dishwasher and the adjacent wall.
- Provide at least 27" in front of the dishwasher to allow the dishwasher door to open fully. Refer to Figure B

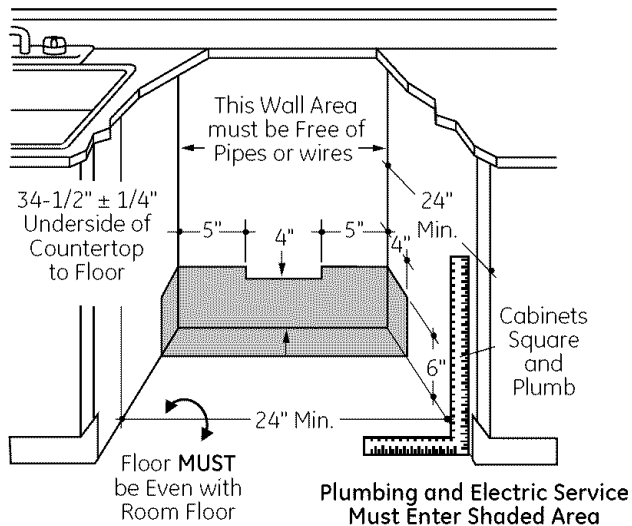

Figure A

- Make sure the floor is level inside the opening and even with the finished floor of the kitchen. This will facilitate removal of the dishwasher at a later date for service, if needed.

- The dishwasher must be installed no more than 10 feet from sink for proper drainage.
- The dishwasher must be fully enclosed on the top, sides, and back.
- The dishwasher must not support any part of the enclosure.

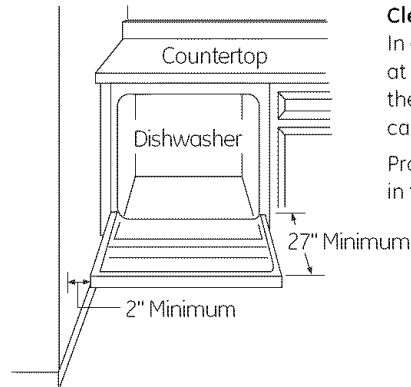

Figure B

Clearances:

In a corner installation, provide at least 2" clearance between the dishwasher and the adjacent cabinet, wall, or other appliance.

Provide at least 27" of clearance in front of the dishwasher.

Installation Preparation–Drain

PREPARE DRAIN PLUMBING

Drain Requirements

- Follow local codes and ordinances.
- Drain hose must not exceed 10 feet in length.
- A high drain loop or air gap is required. See below.

Drain Method

The type of drain installation depends on the following:

- Do local codes or ordinances require an air gap?
- Is waste tee less than 18" above the floor?

If the answer to either question is **YES**, an air gap (**Method 1**) must be used. If both answers are **NO**, either an air gap or a high drain loop (**Method 2**) may be used.

Special consideration for a dishwasher installed on a pedestal

If the dishwasher is installed on an elevated platform, a high drain loop of at least 32" above the platform must be provided in addition to the air gap requirement determined above. This is necessary for proper drain performance.



CAUTION

An air gap **MUST BE USED** if the drain hose is connected to waste tee or disposer lower than 18" above the floor level. Failure to provide the proper drain connection height with an air gap or 32" minimum, high drain loop will result in improper draining of the dishwasher, which may cause damage.

METHOD 1–Air Gap with Waste Tee or Disposer

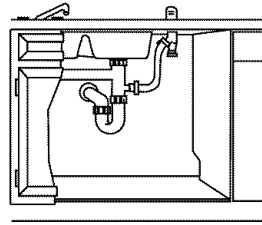

Waste Tee Installation

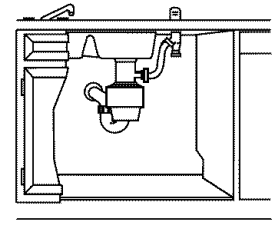

Disposer Installation

Figure C

METHOD 2–High Drain Loop with Waste Tee or Disposer

Provide a method to attach the drain hose to the underside of countertop. Attachment will be made in a later step.

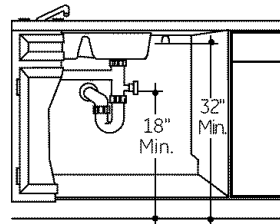

Waste Tee Installation

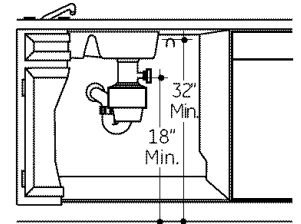

Disposer Installation

Figure D

Install waste tee or disposer and the air gap according to the manufacturer's instructions.

Cabinet Preparation

Drill a 1-1/2" diameter hole in the cabinet wall within the shaded area shown in Figure A for the drain hose. Make sure there are no sharp edges. The drain hose will be passed through this hole and connected to the drain in a later step.

IMPORTANT – When connecting the drain line to a disposer, check to be sure that drain plug has been removed. Dishwasher will not drain if plug is left in place.

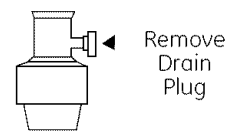

Installation Preparation—Electrical Supply

PREPARE ELECTRICAL WIRING

⚠ WARNING



FOR PERSONAL SAFETY: Remove house fuse or open circuit breaker before beginning installation. Do not use an extension cord or adapter plug with this appliance.

Electrical Requirements

- This appliance must be supplied with 120V, 60 Hz., and connected to an individual properly grounded branch circuit, protected by a 15 or 20 ampere circuit breaker or time delay fuse.
- Wiring must be 2 wire with ground.
- If the electrical supply does not meet the above requirements, call a licensed electrician before proceeding.

Grounding Instructions—Permanent Connection

This appliance must be connected to a grounded metal, permanent wiring system, or an equipment grounding conductor must be run with the circuit conductors and be connected to the equipment grounding terminal or lead on the appliance.

Grounding Instructions—Power Cord Models

This appliance must be grounded. In the event of a malfunction or breakdown, grounding will reduce the risk of electric shock by providing a path of least resistance for electric current. This appliance is equipped with a cord having an equipment grounding conductor and a grounding plug. The plug must be plugged into an appropriate outlet that is installed and grounded in accordance with all local codes and ordinances.

⚠ WARNING



The improper connection of the equipment grounding conductor can result in electric shock. Check with a qualified electrician or service representative if you are in doubt that the appliance is properly grounded. Do not modify the plug provided with the appliance; if it will not fit the outlet, have a proper outlet installed by a qualified technician.

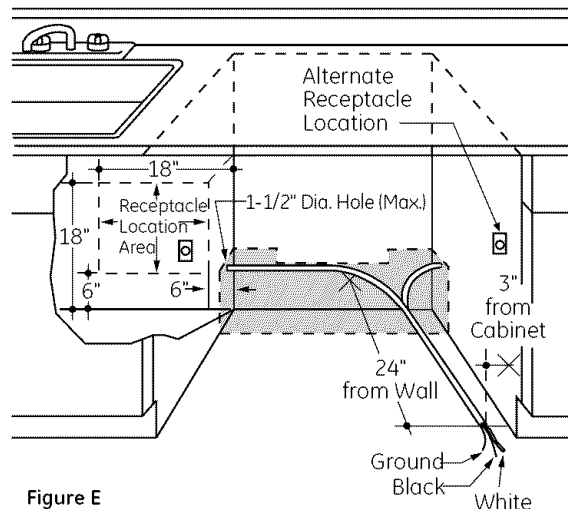
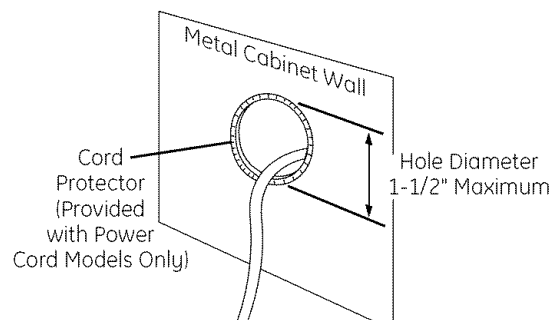

Figure E

Cabinet Preparation & Wire Routing

- The wiring may enter the opening from either side, rear, or floor within the shaded area illustrated above in Figure E and defined in Figure A.
 - Cut a 1-1/2" maximum diameter hole to insert the electrical cable. Permanent wiring connections may pass through the same hole as the drain hose and hot water line, if convenient. Hole edges must be smooth and rounded. If the cabinet wall is metal, the hole edge must be covered with a cord protector.
- NOTE:** Power cords with plug must pass through a separate hole.



Electrical Connection to Dishwasher

Electrical connection is on the right front of dishwasher.

- For permanent connections, the cable must be routed as shown in Figure E. The cable must extend a minimum of 24" from the rear wall.
- For power cord connections, install a 3-prong grounding type receptacle in the adjacent cabinet rear wall, between 6" and 18" from the opening, 6" to 18" above the floor as shown in Figure E.

Installation Preparation–Hot Water Supply

PREPARE HOT WATER SUPPLY

Hot Water Line

- The line may enter from either side, rear, or floor within the shaded area shown in Figure F.
- The line may pass through the same hole as the electrical cable and drain hose, or cut an additional 1-1/2" diameter hole to accommodate the water line. If a power cord with plug is used, the water line must not pass through the power cord hole.



CAUTION

The hot water supply line pressure must be at least 20 PSI. Lower pressures could cause the water valve to leak and cause water damage.

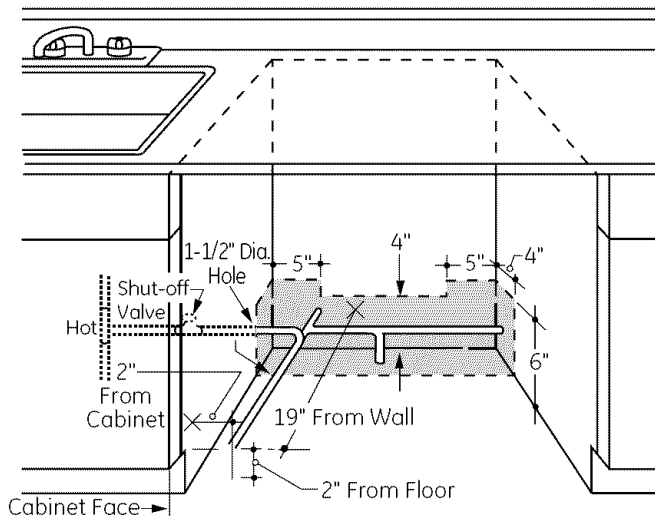

Figure F

Water Line Connection

- Turn off the water supply.
- Install a hand shut-off valve in an accessible location, such as under the sink. (Optional, but strongly recommended and may be required by local codes.)
- The water connection is on the left side of the dishwasher. Install the hot water inlet line, using 3/8" or larger copper tubing. Route the line as shown in Figure F and extend forward at least 19" from rear wall.
- Adjust the water heater to deliver water between 120°F and 150°F.
- Flush water line to clean out debris. Use a bucket to catch water and debris.
- The hot water supply line pressure must be between 20 and 120 PSI.

Dishwasher Installation



CAUTION

Do not remove the wood base until you are ready to install the dishwasher. The dishwasher will tip over when the door is opened if the base is removed.

STEP 1: PREPARATION

Locate the items in the installation package and set them aside for use in the listed steps.

- Screw kit—Steps 5 or 16 and 13
- Junction box cover—Steps 5 or 16
- Drain hose and drain hose clamp—Step 7
- Owners' Manual—Steps 18 and 21
- Product Samples and/or coupons—Step 21
- Conversion leads (Factory-equipped Power Cord Models Only) —Appendix

STEP 2: CHECK DOOR BALANCE

- With the dishwasher on the wood base, check the door balance by opening and closing the door.
- The door is properly balanced if it gently drops from a 1/2 open position and does not rise from the full open position.
- If necessary, increase or decrease tension as shown. Latch the door and adjust springs to correct balance.

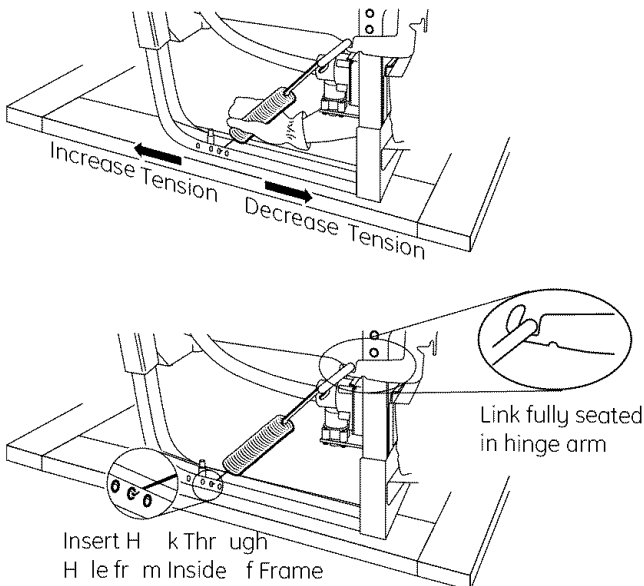

Figure G

Tip: Avoid service calls for door balance problems

Make sure the spring end is fully engaged in a frame hole and the spring link is fully seated in the hinge arm.

STEP 3: REMOVE WOOD BASE

IMPORTANT – Do not kick off wood base! Damage will occur.

- Move the dishwasher close to the installation location and lay it on its back.
- Remove the four leveling legs from the underside of the wood base with a 15/16" socket wrench.
- Remove and discard wood base.

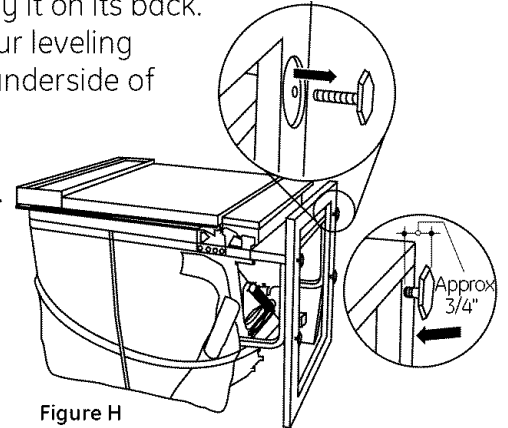

Figure H

- Screw leveling legs back into the dishwasher frame, approximately 3/4" from the frame, as shown.

STEP 4: REMOVE ACCESS PANEL AND TOEKICK

The top mounting holes in the access panel are slotted.

- Remove the lower two 10-16x3/8" sheet metal screws. Do not remove the two top 8-32x1/4" machine thread screws.
- Slide the access panel to the left as far as it will go.
- Gently pull the access panel forward to remove it from the top screws.

Set access panel, toekick, and screws aside for use in Step 20.

Tip: Prevent tub damage

Remove only the 3/8" sheet metal screws in this step. This will help prevent a mix up with the 1/4" machine thread screws in Step 20.

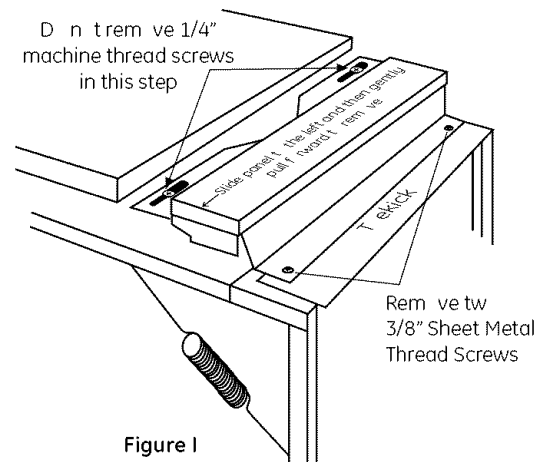

Figure I

Dishwasher Installation

STEP 5: INSTALL POWER CORD

Skip this step if the dishwasher will be permanently connected to the house electrical system or has a factory installed power cord.

In this step you will need the junction box cover and the #10 x 1/2" hex head screw from the screw kit set aside in Step 1.

The power cord and connections must comply with the National Electrical Code, Section 422 and/or local codes and ordinances. Maximum power cord length is 6 feet. Power Cord Kit WX09X70910, available for purchase from an authorized GE Appliance Dealer, meets these requirements.

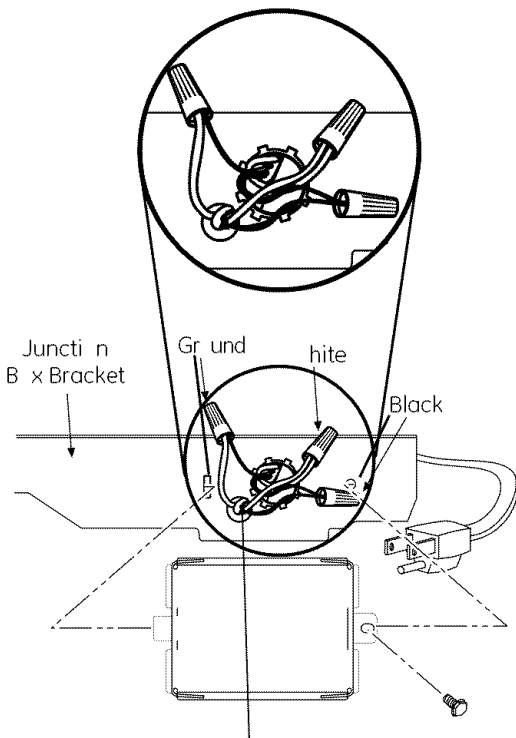

Figure J

- Install strain relief in the junction box bracket.
- Insert the power cord through the strain relief and tighten.
- Make sure black, white, and green dishwasher wires are threaded through the small hole in the junction box bracket.
- Connect power cord white (or ribbed) to dishwasher white, black (or smooth) to dishwasher black and ground to dishwasher green wire. Use UL listed wire nuts of appropriate size.
- Install junction box cover using the #10 hex head screw. Be sure wires are not pinched under the cover.

STEP 6: INSTALL 90° ELBOW

- Wrap a 90° elbow with thread seal tape.
- Thread the 90° elbow into the water valve.
- Do not over tighten the elbow; water valve bracket could bend or the valve fitting could break.
- Position the end of the elbow to face the rear of the dishwasher.

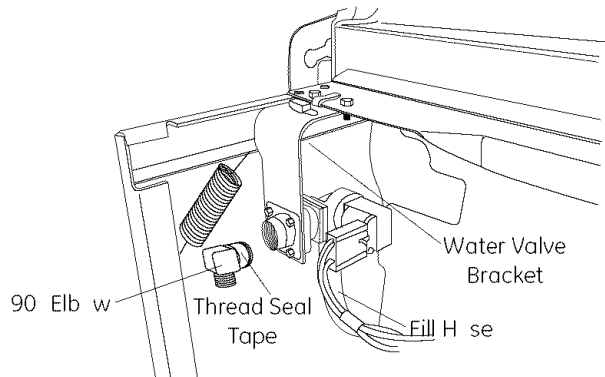

Figure K

STEP 7: INSTALL DRAIN HOSE TO DISHWASHER DRAIN PORT

Skip this step if drain hose has been pre-installed.

In this step you will need the drain hose and clamp set aside in Step 1.

IMPORTANT – Prevent drain hose damage and possible leaks. Be careful not to nick or cut the drain hose.

- Route the small end of the drain hose from the left side of the dishwasher through the strain relief attached to the dishwasher frame and toward the center of the dishwasher as shown in Figures L and M.
- Place the hose clamp over the small end of the drain hose.
- Push the small end of the drain hose over the drain port on the collection chamber making sure it is fully seated against the hose stop.
- Tighten the hose clamp to at least 15 inch-pounds of torque.

Note: The drain hose supplied with the dishwasher

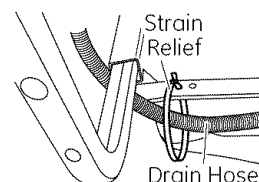

Figure L

Dishwasher Installation

is approximately 78" long. If a longer hose is needed, a 10 foot long hose may be purchased from an authorized GE appliance dealer. The 10 foot long hose is part number **GPF10S**.

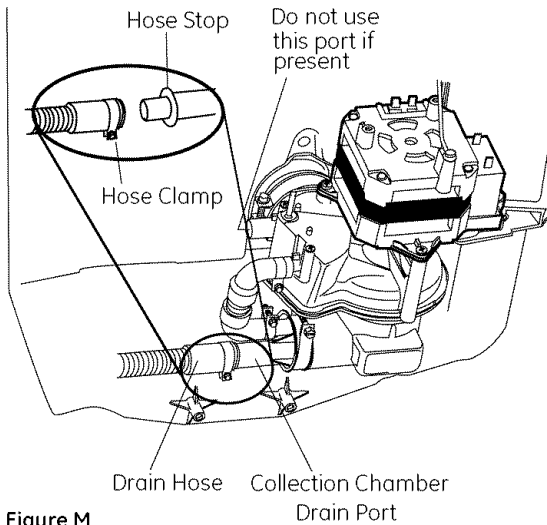

Figure M

Tip: Avoid unnecessary service charges for drain issues

Make sure the drain hose connection is leak free and the hose is routed through the strain relief so it will not kink when the dishwasher is installed into the cabinet.

STEP 8: POSITION WATER LINE AND POWER SUPPLY

- Position the water supply line and house wiring on the floor of the opening to avoid interference with the base of dishwasher and components under the dishwasher.

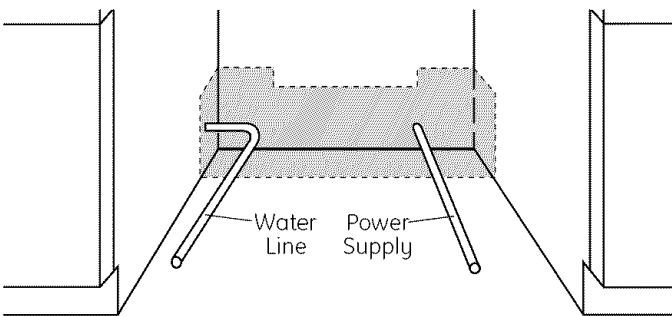

Figure N

STEP 9: INSERT DRAIN HOSE AND POWER CORD, IF USED, THROUGH CABINET

- Upright the dishwasher and position it in front of the cabinet opening.
- Insert the drain hose into the hole previously drilled in the cabinet wall.
- If a power cord is used, guide the end of the cord through a separate hole cut for the power cord.

The power cord should be routed directly to the rear of the junction box avoiding contact with the door spring and other dishwasher components.

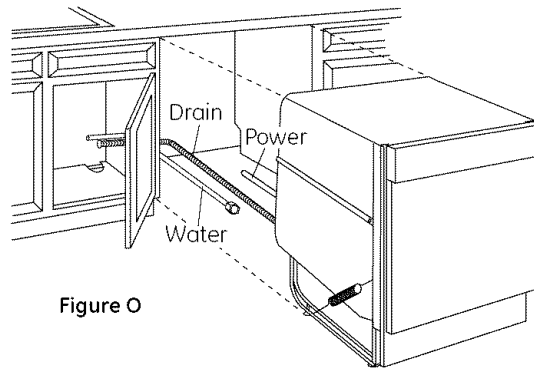

Figure O

Tip: Avoid unnecessary service charges for no fill, drain, or noise concerns

Position utility lines so they do not interfere with anything under or behind the dishwasher.

STEP 10: INSTALL OPTIONAL GPF65 SIDE MOUNT BRACKETS

Skip this step if the underside of countertop is wood or wood like material.

- Purchase and install the **GPF65** side mount bracket kit if the underside of counter is granite or a similar material that will not accept wood screws. The **GPF65** kit is available from authorized GE appliance dealers.
- Refer to Figure P and follow the instructions included in the kit.

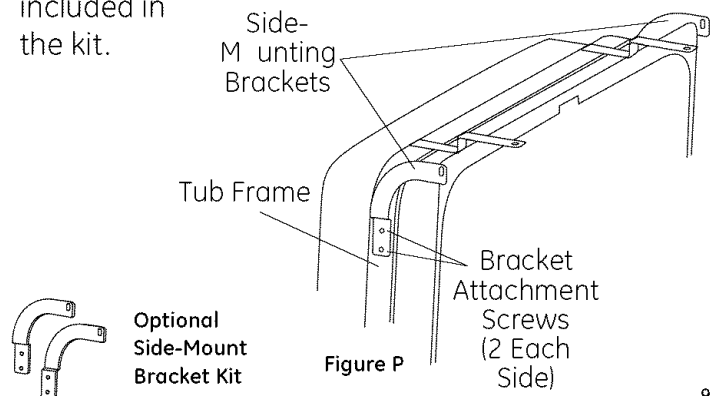
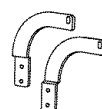

Figure P



Optional Side-Mount Bracket Kit

Dishwasher Installation

STEP 11: SLIDE DISHWASHER INTO CABINET

IMPORTANT – Do not push against the front panel with knees. Damage will occur.

- Grasp the sides of the front panel and slide the dishwasher into the opening a few inches at a time. Pull the drain hose and power cord, if equipped, through the holes in the adjacent cabinet while sliding the dishwasher into position.

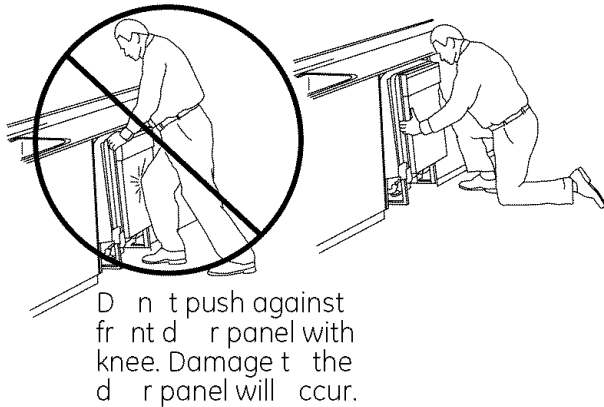

Figure Q

- Check the tub insulation blanket, if equipped, to be sure it is smoothly wrapped around the tub. It should not be “bunched up” and it must not interfere with the door springs. If the insulation is “bunched up” or interfering with the springs, straighten and re-center the blanket prior to sliding the dishwasher into its final position.
- Make sure the drain hose is not kinked under or behind the dishwasher.
- Make certain the house wiring, drain line, and water line do not interfere with components under the dishwasher.
- The dishwasher tub flange should be approximately 3/4" behind the face of the adjacent cabinet. Refer to Figure R.

Tip: Avoid unnecessary service charges for panel damage.

Do not press on the center of panel with hands or knees when sliding dishwasher into position.

STEP 12: POSITION AND LEVEL DISHWASHER

IMPORTANT – Dishwasher must be level for proper dish rack operation, wash performance, and door operation. The dishwasher must be leveled left to right and front to back. This assures that the dish racks will not roll in or out on their own, circulation water will flow to the pump inlet, and the door will close without hitting the side of the tub.

- Remove the lower dish rack and place a level on the door and lower rack track as shown in Figure R.

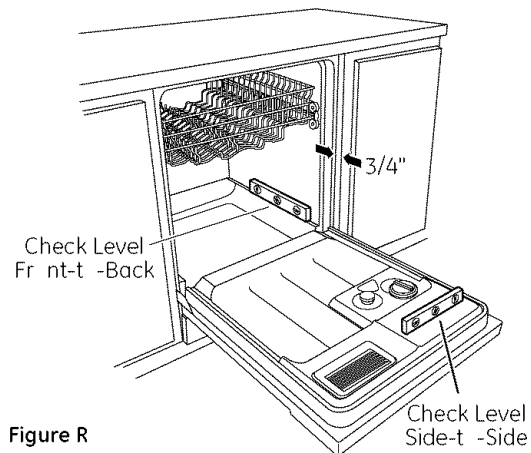

Figure R

- Adjust the level of the dishwasher by individually turning the four legs on the bottom of the dishwasher as illustrated in Figure S.

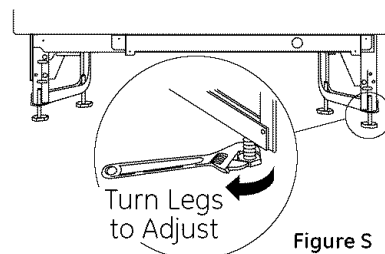

Figure S

- The dishwasher is properly leveled when the level indicator is centered left to right and front to back. The dishwasher door should close without hitting the sides of the tub.
- Replace the lower rack.

Tip: Avoid unnecessary service charges for poor wash performance and rack operation.

Pull the dish racks half way out. They should remain stationary. Open and close the door. The door should fit in the tub opening without hitting the side of the tub. If the racks roll on their own, or the door hits the side of the tub, re-level the dishwasher.

Dishwasher Installation

STEP 13: FASTEN DISHWASHER TO UNDERSIDE OF COUNTERTOP OR SIDES OF CABINET

In this step you will need the two 5/8" Phillips head wood screws set aside in Step 1.

IMPORTANT – Dishwasher must be centered in cabinet opening. Interference with cabinets or countertop will cause leaks and damage to the door panel and/or control panel.

- If countertop is wood or woodlike material, fasten the dishwasher to the countertop by driving the Phillips head screws through the countertop brackets and into the countertop.
- If the countertop is granite or similar material, drive Phillips screws through side mount brackets and into the adjacent cabinets.
- Make sure screws are driven straight and flush to prevent interference with door operation and damage to the control panel. See Figure T.

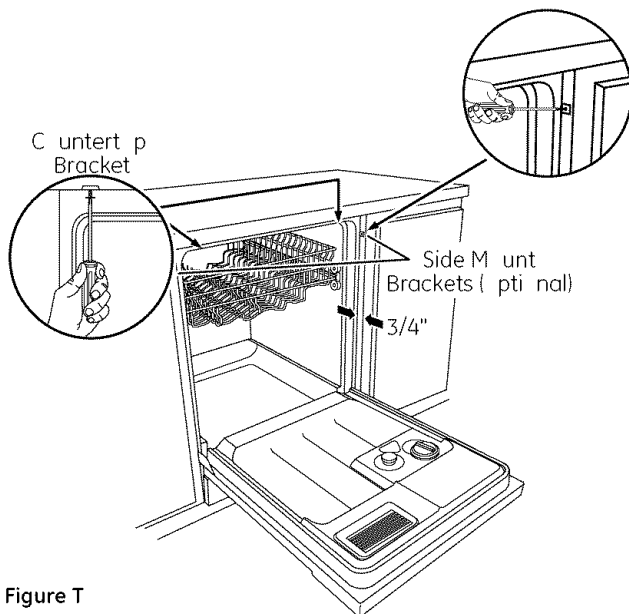

Figure T

Tip: Avoid unnecessary service charges for leaks or control panel damage.

Make sure the dishwasher is centered in the cabinet and the door opens and closes freely without hitting the adjacent cabinets. Drive mounting screws straight and flush.

STEP 14: CONNECT WATER SUPPLY

Connect the water supply line to the 90° elbow installed in Step 6.

- Slide the compression nut and then the ferrule over end of the water line.
- Insert the water line into the 90° elbow.
- Slide the ferrule against the elbow and secure with the compression nut.

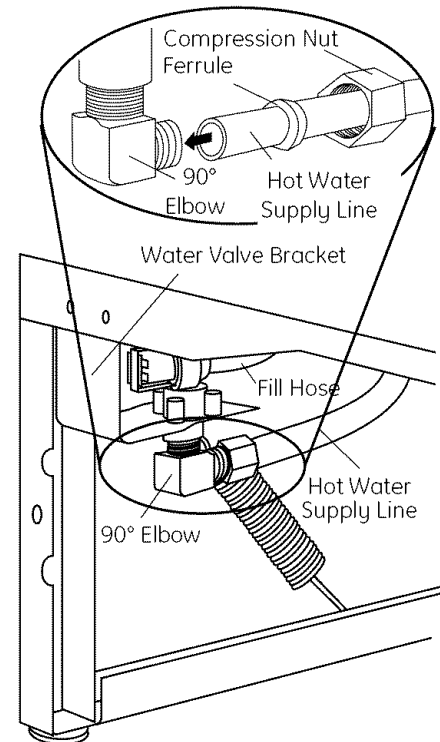

Figure U

IMPORTANT – Check to be sure the door spring does not rub or contact the fill hose or water supply line. Test by opening and closing the door. Re-route the water supply lines or slightly bend the water valve bracket if a rubbing noise or interference occurs.

Tip: Avoid unnecessary service charges for noise or leaks

Make sure the door spring does not rub against the fill hose or water supply line.

Dishwasher Installation

STEP 15: CONNECT DRAIN LINE

The molded end of the drain hose will fit 5/8" through 1" diameter inlet ports on the air gap, waste tee or disposer.

- Determine the size of the inlet port
- Cut the drain hose connector on the marked line, if required, to fit the inlet port.

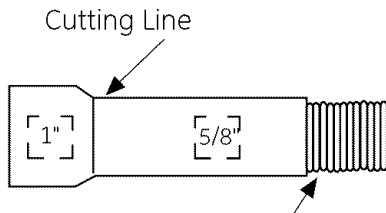

Figure V

IMPORTANT: Do not cut corrugated portion of hose

- If a longer drain hose is required, and you did not purchase the GPF10S drain hose, add up to 42" length, for a total of 120" (10 feet) to the factory installed hose. Use 5/8" or 7/8" inside diameter hose and a coupler to connect the two hose ends.

Secure the connection with hose clamps.

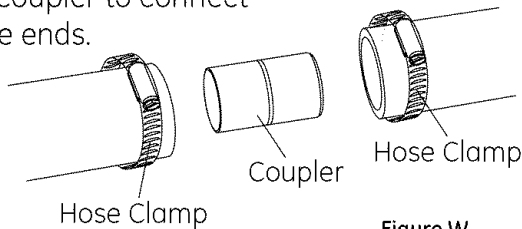

Figure W

IMPORTANT – Total drain hose length must not exceed 10 feet for proper drain operation.

- Connect drain line to air gap, waste tee, or disposer using the previously determined method. Secure the hose with a screw type clamp.

Method 1 – Air gap with waste tee or disposer

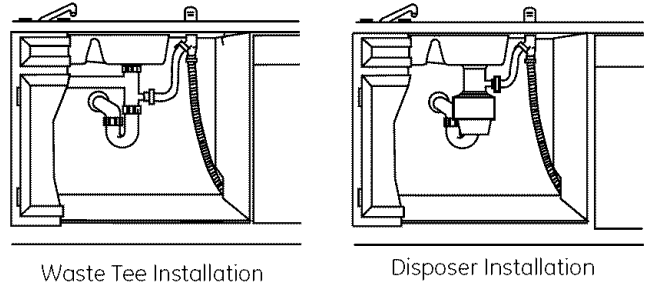

Figure X

Method 2 – "High drain loop" with waste tee or disposer

Fasten the drain hose to the underside of the countertop with a hanger.

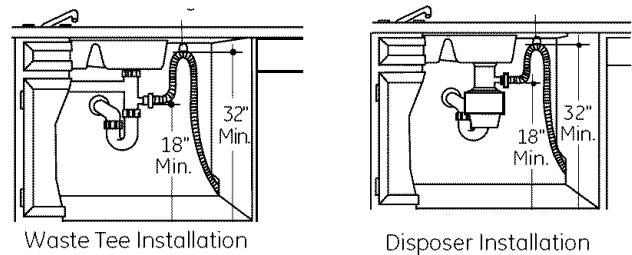
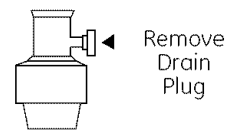

Figure Y

IMPORTANT – When connecting the drain line to a disposer, check to be sure that the drain plug has been removed. Dishwasher will not drain if plug is left in place.



Tip: Avoid unnecessary service call charges for a no drain complaint

Make sure any excess drain hose has been pulled through the cabinet opening. This will prevent excess hose in the dishwasher cavity from becoming kinked or crushed by the dishwasher. Make sure the disposer plug has been removed if the drain hose is connected to a disposer.

Dishwasher Installation

STEP 16: CONNECT POWER SUPPLY

If a power cord with plug is already installed, proceed to Step 17.

If the dishwasher came with a factory-installed power cord and you want to convert it to a permanent connection, refer to the instructions on page 16.

⚠ WARNING



If house wiring is not 2-wire with a ground wire, a ground must be provided by the installer.

When house wiring is aluminum, be sure to use U.L. listed anti-oxidant compound and aluminum-to-copper connectors.

- Secure house wiring to the back of the junction box bracket with a strain relief.
- Locate the three dishwasher wires, (white, black and green) with stripped ends. Insert dishwasher wires through the small hole in the junction box bracket. Use UL listed wire nuts of appropriate size to connect incoming ground to green, white to white and black to black.

Note: Check that harness lead are threaded through small hole in bracket

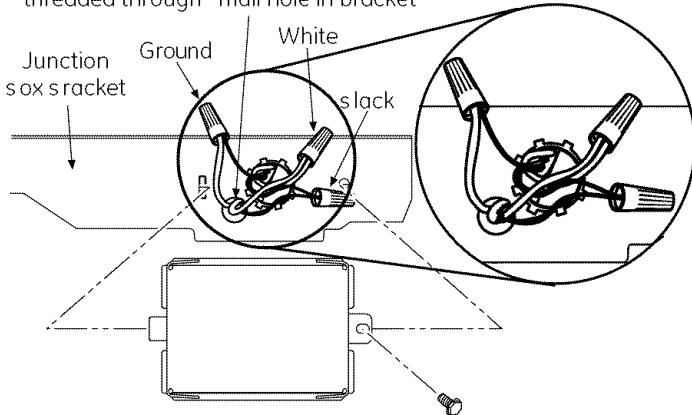

STEP 17: INSTALL JUNCTION BOX COVER

If junction box cover is already installed, skip to Step 18.

In this step you will need the junction box cover and the #10 hex head screw from the screw kit set aside in Step 1.

- Install the junction box cover using the #10 hex head screw. Check to be sure that wires are not pinched under the cover.

STEP 18: PRE-TEST CHECK LIST

- Verify that power is turned off at the source.
- Open the dishwasher door and remove all foam and cardboard packaging.
- Read the Owner's Manual to familiarize yourself with the operation of the dishwasher.
- Check to be sure that the wiring is secure under the dishwasher, and not pinched or in contact with door springs or other dishwasher components.
- Check that the door spring does not contact the water line, fill hose, or adjacent cabinets. See Steps 13 and 14
- Pull lower rack about halfway out. Check to be sure it does not roll back into dishwasher or further out. If it does, re-level the dishwasher. See Step 12
- Check to be sure control panel does not touch adjacent cabinets. If it does, reposition the dishwasher. See Step 13
- Turn on the hot water faucet at the sink to verify that the water temperature is at least 120°F and not more than 150°F. Adjust water heater if necessary.
- Add two quarts of water to the bottom of the dishwasher to lubricate the pump seal.
- Turn on water supply.
- Check for water leaks. Tighten connections if necessary. See Step 14
- Remove the protective film if present from the control panel, access panel and door panel.

Dishwasher Installation

STEP 19: DISHWASHER WET TEST CHECK LIST

- Turn on power supply or if power cord is used, plug it into the wall outlet.
- Latch dishwasher door.
- For electronic dishwashers, select the normal cycle and press the start pad one time.

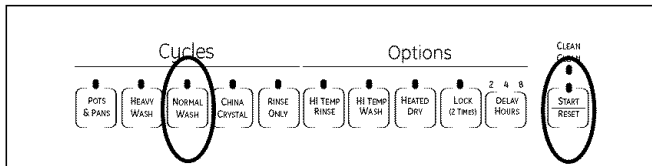

- For dial models, press the normal and hot start pads, if model has them, and then turn control dial just enough to start dishwasher. Be careful not to turn the dial past the first water fill. Dial should point to "Hot Start Option" or "Hot Pre-wash Option" depending on model.

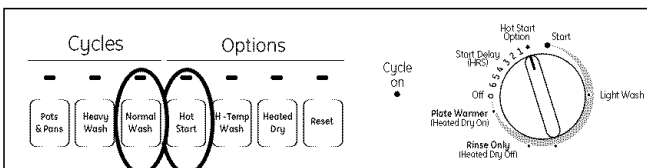

Appearance varies by model. Not all models have pushbuttons.

- Check to be sure that water enters the dishwasher. This could take up to 4 minutes.
If water does not enter the dishwasher
 - Check to be sure that the water is turned on
 - Lightly tap the flood float cover to dislodge a stuck flood float.

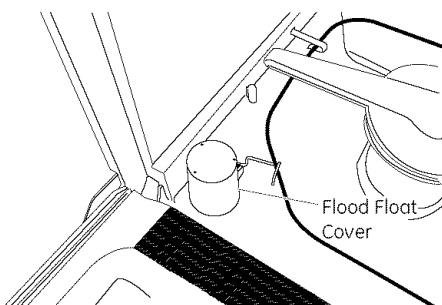

- Check the electrical connection to the water valve. The red electrical connector should be plugged into the dishwasher water valve. If it is not plugged in, turn off electrical power to the dishwasher. Plug the red connector into the dishwasher water valve and then restore power.

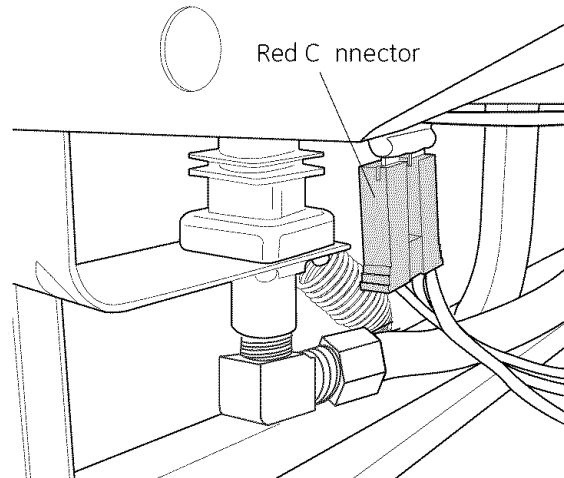

- Check for leaks under the dishwasher. If a leak is found, turn off power, tighten connections and restore power.
- Check for leaks around the door. A leak around the door could be caused by the dishwasher door rubbing or hitting adjacent cabinets. Reposition the dishwasher if necessary. See Steps 11, 12 and 13.
- Most dishwasher models will drain about 3 minutes after the first fill. Check the drain line for leaks when dishwasher drains. If leaks are found, turn off power, correct as necessary and then restore power.
- Open the dishwasher door and make sure most of the water has drained. If the water does not drain, check to be sure disposer plug has been removed and/or air gap is free of debris.
- Let the dishwasher run through another fill and drain cycle. Check again to be sure there are no leaks.
- At the end of the second drain, push the reset pad on electronic models. For dial models, unlatch the door and rotate the dial to the "OFF" position.

Dishwasher Installation

STEP 20: REPLACE ACCESS PANEL AND TOEKICK

In this step you will need the panels and the two screws set aside in Step 4.

There are two types of screws used. The 8-32 x 1/4" screws are used at the top of the access panel and should still be in place. The 10-16 x 3/8" screws are used at the bottom of the access panel and secure both the access panel and toekick.

IMPORTANT – Screws are not interchangeable. To prevent damage to your dishwasher, use the proper screw in the proper location. Do not mix screw types or lengths.

- Place the toekick against the legs of the dishwasher.
- Remove the two 8-32 x 1/4" machine thread screws.
- Align the access panel to the dishwasher.
- Select the two 8-32 x 1/4" machine thread screws just removed and insert them through the top holes in the access panel and into the dishwasher frame.
- Tighten these screws.
- Align the toekick and make sure the bottom edge is against the floor.
- Insert and tighten the two 10-16 x 3/8" sheet metal thread screws, making sure the bottom edge of the toekick stays in contact with the floor.

STEP 21: LITERATURE

- Leave the Owners' Manual, Installation Instructions, samples, and/or coupons with consumer.

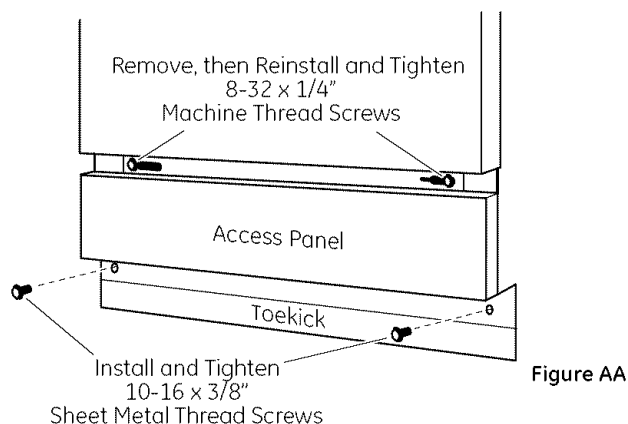

Tip: Prevent tub damage and reduce sound from under the dishwasher

Use the machine thread screws in the top holes and the sheet metal thread screws in the bottom holes. Make sure the toekick is against the floor.

Appendix

CONVERTING DISHWASHER WITH FACTORY EQUIPPED POWER CORD TO A PERMANENT CONNECTION

This procedure requires the conversion leads set aside in Step 1.

- Make sure the power cord for the dishwasher is unplugged from the wall outlet.
- Remove screw from junction box cover and remove cover if present.
- Disconnect the three power cord conductors from the dishwasher harness. Figure BB
- Remove and discard the power cord.
- Connect the conversion harness (included with dishwasher) to the dishwasher harness by connecting like-colored wires. Figure CC
- Return to Step 16 in these instructions to complete the conversion.

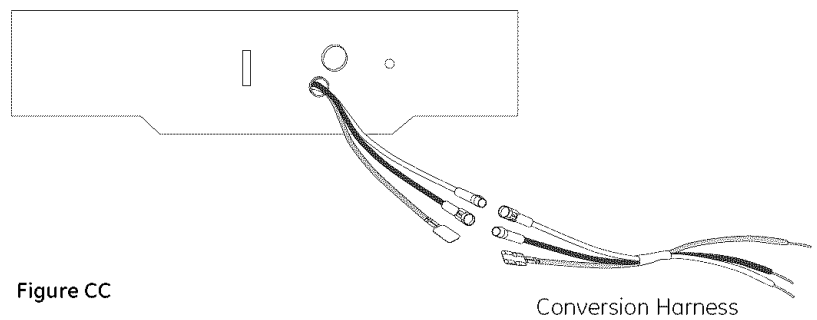
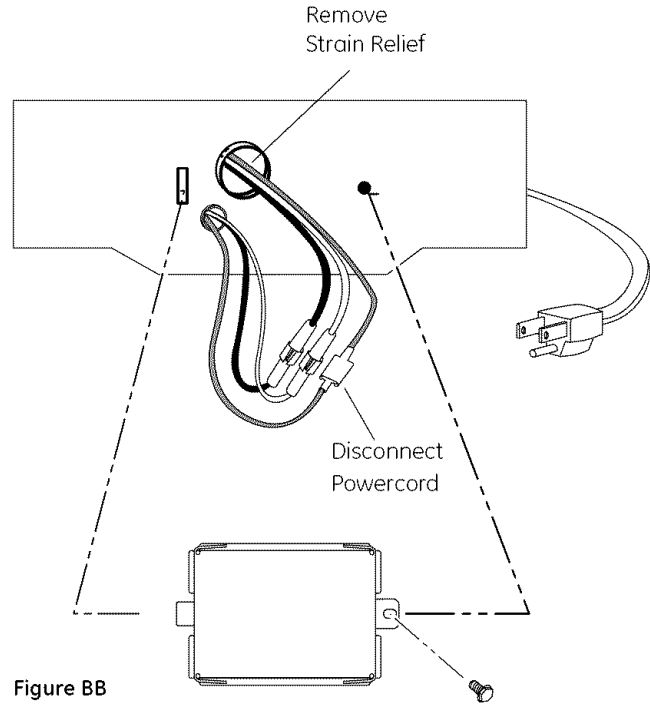

SPECIFICATIONS SUBJECT TO CHANGE WITHOUT NOTICE



GE Consumer & Industrial
General Electric Company
Louisville, Kentucky 40225

ge.com

Pub. No. 31-30218
Dwg. No. 206C1559P158
ND 06H-1949 (10/06)