

SEARS

OWNER'S
MANUAL

MODEL NO.
315.108240

CAUTION:
Read Rules for
Safe Operation
and All Instruc-
tions Carefully

**SAVE THIS
MANUAL FOR
FUTURE REFERENCE**

Thank You for Buying A
Craftsman Circular Saw

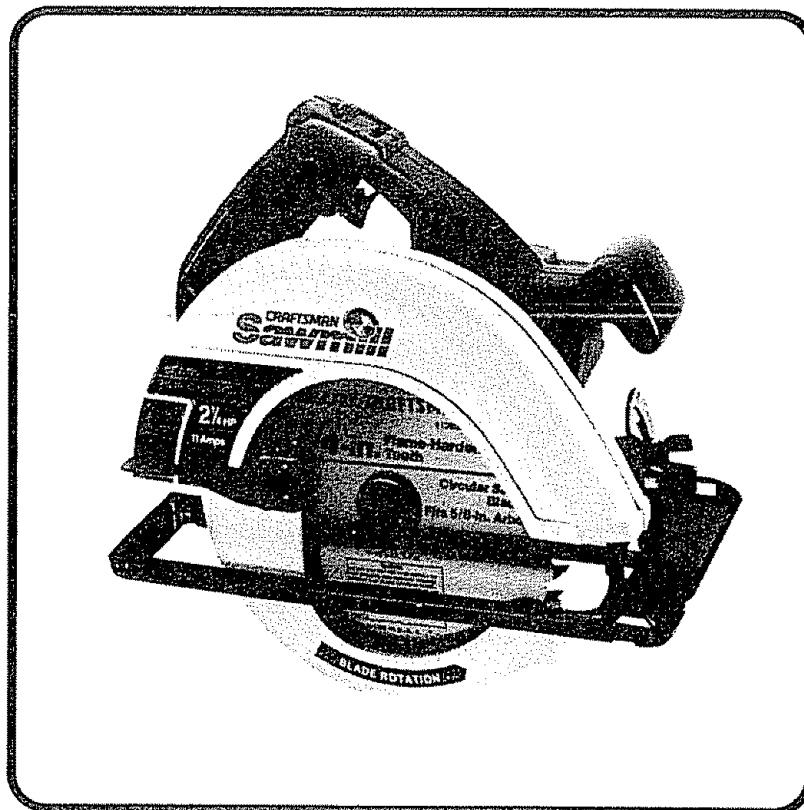

CRAFTSMAN
7-1/4 INCH CIRCULAR SAW
DOUBLE INSULATED

Warranty
Introduction
Operation
Maintenance
Repair Parts



Designed exclusively for and sold only by
SEARS, ROEBUCK AND CO., Sears Tower, Chicago, IL 60684

FULL ONE YEAR WARRANTY ON CRAFTSMAN CIRCULAR SAW

If this Craftsman Circular Saw fails to give complete satisfaction within one year from the date of purchase **RETURN IT TO THE NEAREST SEARS SERVICE CENTER / DEPARTMENT THROUGHOUT THE UNITED STATES** and Sears will repair it, free of charge

If this circular saw is used for commercial or rental purposes this warranty applies for only 90 days from the date of purchase

This warranty gives you specific legal rights, and you may also have other rights which vary from state to state

SEARS, ROEBUCK AND CO.
DEPT. 731CR-W
SEARS TOWER
CHICAGO, IL 60684

INTRODUCTION

DOUBLE INSULATION is a concept in safety, in electric power tools, which eliminates the need for the usual three wire grounded power cord and grounded supply system. Wherever there is electric current in the tool there are two complete sets of insulation to protect the user. All exposed metal parts are isolated from internal metal motor components with protecting insulation

IMPORTANT - Servicing of a tool with double insulation requires extreme care and knowledge of the system and should be performed only by a qualified service technician. For service we suggest you return the tool to your nearest Sears store for repair. Always use original factory replacement parts when servicing.

RULES FOR SAFE OPERATION

WARNING - DO NOT ATTEMPT TO OPERATE THIS TOOL UNTIL YOU HAVE READ THOROUGHLY AND UNDERSTAND COMPLETELY ALL INSTRUCTIONS, SAFETY RULES, ETC. CONTAINED IN THIS MANUAL. FAILURE TO COMPLY CAN RESULT IN ACCIDENTS INVOLVING FIRE, ELECTRIC SHOCK, OR SERIOUS PERSONAL INJURY. SAVE OWNER'S MANUAL AND REVIEW FREQUENTLY FOR CONTINUING SAFE OPERATION, AND INSTRUCTING POSSIBLE THIRD-PARTY USER.

READ ALL INSTRUCTIONS

- 1. KNOW YOUR POWER TOOL.** Read owner's manual carefully. Learn its applications and limitations as well as the specific potential hazards related to this tool
- 2. GUARD AGAINST ELECTRICAL SHOCK BY PREVENTING BODY CONTACT WITH GROUNDED SURFACES.** For example; pipes, radiators, ranges, refrigerator enclosures
- 3. KEEP GUARDS IN PLACE AND IN WORKING ORDER.** Never wedge or tie lower blade guard open. Check operation of lower blade guard before each use. Do not use if lower blade guard does not close briskly over saw blade. **WARNING: IF SAW IS DROPPED, LOWER BLADE GUARD MAY BE BENT, RESTRICTING FULL RETURN.** If lower blade guard becomes bent or damaged, replace it before reuse
- 4. KEEP WORK AREA CLEAN.** Cluttered areas and benches invite accidents.
- 5. AVOID DANGEROUS ENVIRONMENT.** Don't use power tools in damp or wet locations or expose to rain. Keep work area well lit
- 6. KEEP CHILDREN AND VISITORS AWAY.** All visitors should wear safety glasses and be kept a safe distance from work area. Do not let visitors contact tool or extension cord
- 7. STORE IDLE TOOLS.** When not in use, tools should be stored in a dry and high or locked-up place - out of the reach of children.
- 8. DON'T FORCE TOOL.** It will do the job better and safer at the rate for which it was designed.
- 9. USE RIGHT TOOL.** Don't force small tool or attachment to do the job of a heavy duty tool. Don't use tool for purpose not intended - for example - Don't use a circular saw for cutting tree limbs or logs.
- 10. DRESS PROPERLY.** Do not wear loose clothing or jewelry. They can be caught in moving parts. Rubber gloves and non-skid footwear are recommended when working outdoors. Also wear protective hair covering to contain long hair.
- 11. ALWAYS WEAR SAFETY GLASSES.** Everyday eyeglasses have only impact-resistant lenses; they are NOT safety glasses
- 12. PROTECT YOUR LUNGS.** Wear a face or dust mask if the cutting operation is dusty

RULES FOR SAFE OPERATION (Continued)

13. **PROTECT YOUR HEARING.** Wear hearing protection during extended periods of operation.
14. **DON'T ABUSE CORD.** Never carry tool by cord or yank it to disconnect from receptacle. Keep cord from heat, oil, and sharp edges.
15. **SECURE WORK.** Use clamps or a vise to hold work. Both hands are needed to operate tool.
16. **DON'T OVERREACH.** Keep proper footing and balance at all times. Do not use on a ladder or unstable support. Secure tools when working at elevated positions.
17. **MAINTAIN TOOLS WITH CARE.** Keep tools sharp and clean for better and safer performance. Follow instructions for lubricating and changing accessories.
18. **DISCONNECT TOOLS.** When not in use, before servicing, or when changing attachments, blades, bits, cutters, etc., all tools should be disconnected.
19. **REMOVE ADJUSTING KEYS AND WRENCHES.** Form habit of checking to see that keys and adjusting wrenches are removed from tool before turning it on.
20. **AVOID ACCIDENTAL STARTING.** Don't carry plugged-in tool with finger on switch. Be sure switch is off when plugging in.
21. **OUTDOOR USE EXTENSION CORDS.** When tool is used outdoors, use only extension cords intended for use outdoors and so marked.
22. **KEEP BLADES CLEAN AND SHARP.** Sharp blades minimize stalling and kickback.
23. **KEEP HANDS AWAY FROM CUTTING AREA.** Keep hands away from blades. Do not reach underneath work while blade is rotating. Do not attempt to remove cut material when blade is moving. **WARNING: BLADES COAST AFTER TURN OFF.**
24. **NEVER USE IN AN EXPLOSIVE ATMOSPHERE.** Normal sparking of the motor could ignite fumes.
25. **INSPECT TOOL CORDS PERIODICALLY** and if damaged, have repaired by authorized service facility. Stay constantly aware of cord location and keep it well away from the rotating blade.
26. **INSPECT EXTENSION CORDS PERIODICALLY** and replace if damaged.
27. **KEEP HANDLES DRY, CLEAN, AND FREE FROM OIL AND GREASE.** Always use a clean cloth when cleaning. Never use brake fluids, gasoline, petroleum-based products, or any strong solvents to clean your tool.
28. **STAY ALERT AND EXERCISE CONTROL.** Watch what you are doing and use common sense. Do not operate tool when you are tired. Do not rush.
29. **CHECK DAMAGED PARTS.** Before further use of the tool, a guard or other part that is damaged should be carefully checked to determine that it will operate properly and perform its intended function. Check for alignment of moving parts, binding of moving parts, breakage of parts, mounting and any other conditions that may affect its operation. A guard or other part that is damaged should be properly repaired or replaced by an authorized service center.
30. **DO NOT USE TOOL IF SWITCH DOES NOT TURN IT ON AND OFF.** Have defective switches replaced by authorized service center.
31. **USE RIP FENCE.** Always use a fence or straight edge guide when ripping.
32. **SUPPORT LARGE PANELS.** To minimize the risk of blade pinching and kickback, always support large panels as shown in figure 6, page 6. When cutting operation requires the resting of the saw on the workpiece, the saw should be rested on the larger portion and the smaller piece cut off.
33. **LOWER BLADE GUARD. WARNING: IF LOWER BLADE GUARD MUST BE RAISED TO MAKE A CUT, ALWAYS RAISE IT WITH THE RETRACTING HANDLE TO AVOID SERIOUS INJURY.** See Figure 18, Page 11.
34. **GUARD AGAINST KICKBACK.** Kickback occurs when the saw stalls rapidly and is driven back towards the operator. Release switch immediately if blade binds or saw stalls. Don't remove saw from work during a cut while the blade is moving. See Pages 6 and 7.
35. **BEFORE MAKING A CUT, BE SURE THE DEPTH AND BEVEL ADJUSTMENTS ARE TIGHT.**
36. **USE ONLY CORRECT BLADES.** Do not use blades with incorrect size holes. Never use blade washers or bolts that are defective or incorrect. The maximum blade capacity of your saw is 7-1/4".
37. **AVOID CUTTING NAILS.** Inspect for and remove all nails from lumber before cutting.
38. **NEVER touch the blade or other moving parts during use.**
39. **NEVER start a tool when its rotating component is in contact with the workpiece.**
40. **NEVER lay a tool down before its moving parts have come to a complete stop.**
41. **DO NOT OPERATE THIS TOOL WHILE UNDER THE INFLUENCE OF DRUGS, ALCOHOL, OR ANY MEDICATION.**
42. **SAVE THESE INSTRUCTIONS.** Refer to them frequently and use them to instruct third party users. If you loan someone this tool, loan them these instructions also.

FEATURES

Features include easily operated bevel cut and depth of cut adjustment mechanisms; positive 0° bevel stop; directed air flow for keeping line of cut clear; blade wrench storage; and lock-off switch. See Figure 1.

Before attempting to use your saw, familiarize yourself with all operating features and safety requirements.

WARNING: IF ANY PARTS ARE MISSING DO NOT OPERATE YOUR SAW UNTIL THE MISSING PARTS ARE REPLACED. FAILURE TO DO SO COULD RESULT IN POSSIBLE SERIOUS PERSONAL INJURY.

SWITCH

Your saw is equipped with a "lock-off" switch, which reduces the possibility of accidental starting. You must depress the button on top of the handle in order to be able to pull the switch trigger. The lock resets each time the trigger is released.

APPLICATIONS

(Use only for the purpose listed below)

1. Cutting all types of wood products (lumber, plywood, paneling)

ELECTRICAL CONNECTION

Your circular saw has a precision built electric motor. It should be connected to a power supply that is 110-120 volts, 60 Hz, AC only (normal household current). Do not operate this tool on direct current (DC). A voltage drop of more than 10 percent will cause a loss of power and overheating. If your saw does not operate when plugged into an outlet, double-check the power supply rating.

WARNING: DO NOT ALLOW FAMILIARITY WITH YOUR SAW TO MAKE YOU CARELESS. REMEMBER THAT A CARELESS FRACTION OF A SECOND IS SUFFICIENT TO INFLICT SEVERE INJURY.

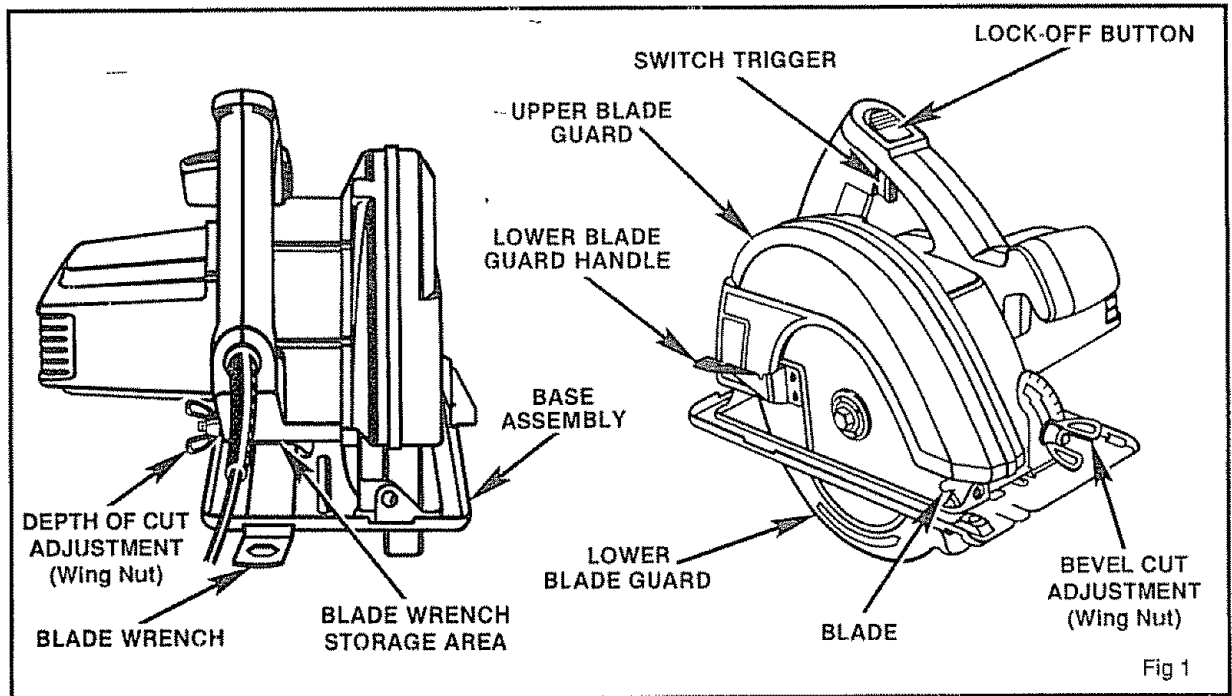

WARNING:



The operation of any Circular Saw can result in foreign objects being thrown into your eyes, which can result in severe eye damage. Before commencing power tool operation, always wear safety goggles or safety glasses with side shields and a full face shield when needed. We recommend Wide Vision Safety Mask for use over spectacles or standard safety glasses with side shields, available at Sears Catalog Order or Retail Stores.

OPERATION

WARNING: YOUR SAW SHOULD NEVER BE CONNECTED TO POWER SUPPLY WHEN YOU ARE ASSEMBLING PARTS, MAKING ADJUSTMENTS, ASSEMBLING OR REMOVING BLADES, CLEANING, OR WHEN NOT IN USE. DISCONNECTING YOUR SAW WILL PREVENT ACCIDENTAL STARTING THAT COULD CAUSE SERIOUS PERSONAL INJURY.

WARNING: 7-1/4" BLADE IS THE MAXIMUM BLADE CAPACITY OF YOUR SAW. ALSO, NEVER USE A BLADE THAT IS TOO THICK TO ALLOW OUTER BLADE WASHER TO ENGAGE WITH THE FLAT ON THE SPINDLE. LARGER BLADES WILL COME IN CONTACT WITH THE BLADE GUARDS, WHILE THICKER BLADES WILL PREVENT BLADE SCREW FROM SECURING BLADE ON SPINDLE. EITHER OF THESE SITUATIONS COULD RESULT IN A SERIOUS ACCIDENT.

TO ASSEMBLE OR REMOVE BLADE

See Figures 2 and 3.

1. Unplug your saw.

WARNING: FAILURE TO UNPLUG YOUR SAW COULD RESULT IN ACCIDENTAL STARTING CAUSING POSSIBLE SERIOUS PERSONAL INJURY.

2. Place your saw on a piece of scrap wood as shown in figure 3 and remove blade screw. **NOTE:** With blade teeth embedded in the wood, turn blade screw counterclockwise to remove.
3. Remove spring washer and outer blade washer ("D" washer). **NOTE: BLADE CAN BE REMOVED AT THIS POINT.** If you are assembling blade for the first time, or changing blades continue to follow the steps below.
4. Wipe a drop of oil onto inner blade washer and outer blade washer ("D" washer) where they contact blade.

WARNING: IF INNER BLADE WASHER HAS BEEN REMOVED, REPLACE IT BEFORE PLACING BLADE ON SPINDLE. FAILURE TO DO SO COULD CAUSE AN ACCIDENT SINCE BLADE WILL NOT TIGHTEN PROPERLY.

5. Fit saw blade inside blade guard and onto spindle. **NOTE:** The saw teeth point upward at the front of saw as shown in figure 2.
6. Replace "D" washer and spring washer. **NOTE:** "Cupped" side of spring washer goes against "D" washer. See Figure 2.
7. Replace blade screw. Tighten blade screw securely. **NOTE:** Turn blade screw clockwise to tighten.

REMEMBER: NEVER USE A BLADE THAT IS TOO THICK TO ALLOW THE "D" WASHER TO ENGAGE WITH THE FLAT ON THE SPINDLE.

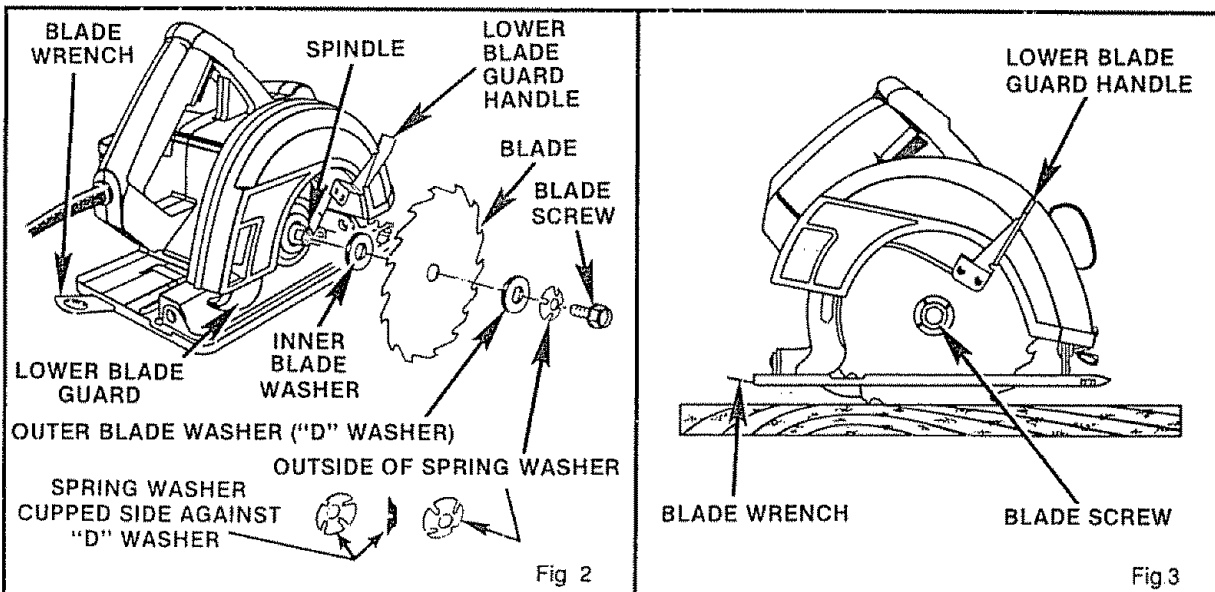

OPERATION

SAW BLADES

The best of saw blades will not cut efficiently if they are not kept clean, sharp, and properly set. Using a dull blade will place a heavy load on your saw and increase the danger of kickback. Keep extra blades on hand, so that sharp blades are always available.

Gum and wood pitch hardened on blades will slow your saw down. Use gum and pitch remover, hot water, or kerosene to remove these accumulations. **DO NOT USE GASOLINE.**

BLADE GUARD SYSTEM

See Figure 4.

The lower blade guard attached to your circular saw is there for your protection and safety. It should never be altered for any reason. If it becomes damaged, do not operate your saw until the damage has been repaired or replaced. Always leave guard in operating position when using your saw.

DANGER: WHEN SAWING THROUGH WORK, LOWER BLADE GUARD DOES NOT COVER BLADE ON THE UNDERSIDE OF WORK. SINCE BLADE IS EXPOSED ON UNDERSIDE OF WORK, KEEP HANDS AND FINGERS AWAY FROM CUTTING AREA. ANY PART OF YOUR BODY COMING IN CONTACT WITH MOVING BLADE WILL RESULT IN SERIOUS INJURY.

Never use saw when guard is not operating correctly. Guard should be checked for correct operation before each use. **NOTE:** The guard is operating correctly when it moves freely and readily returns to the closed position. If you drop your saw, check the lower blade guard for damage at all depth settings before reuse.

KICKBACK

See Figure 5.

THE BEST GUARD AGAINST KICKBACK IS TO AVOID DANGEROUS PRACTICES.

Kickback occurs when the blade stalls rapidly and the saw is driven back towards you. Blade stalling is caused by any action which pinches the blade in the wood.

DANGER: RELEASE SWITCH IMMEDIATELY IF BLADE BINDS OR SAW STALLS. KICKBACK COULD CAUSE YOU TO LOSE CONTROL OF YOUR SAW. LOSS OF CONTROL CAN LEAD TO SERIOUS INJURY.

KICKBACK IS CAUSED BY:

1. Incorrect blade depth setting. See Figure 5.
2. Sawing into knots or nails in work.
3. Twisting blade while making a cut.
4. Making a cut with a dull, gummed up, or improperly set blade.
5. Incorrectly supporting work. See Figure 6.
6. Forcing a cut.
7. Cutting warped or wet lumber.
8. Tool misuse or incorrect operating procedures.

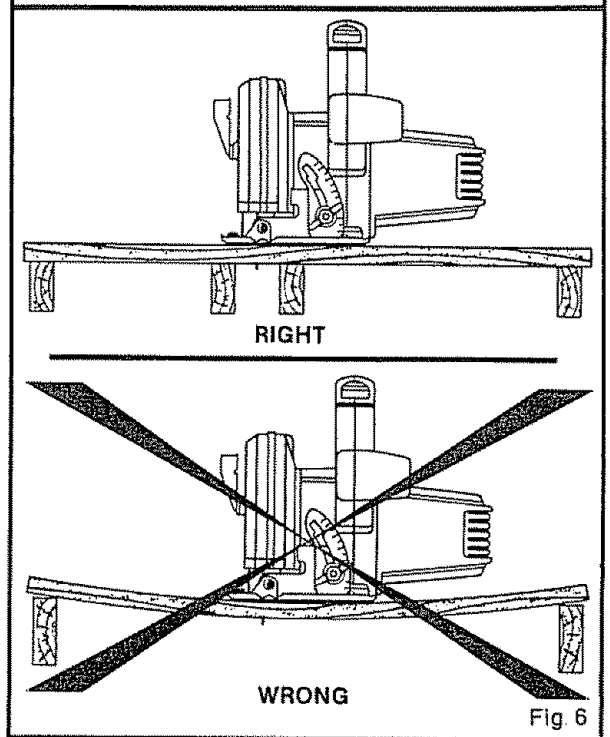
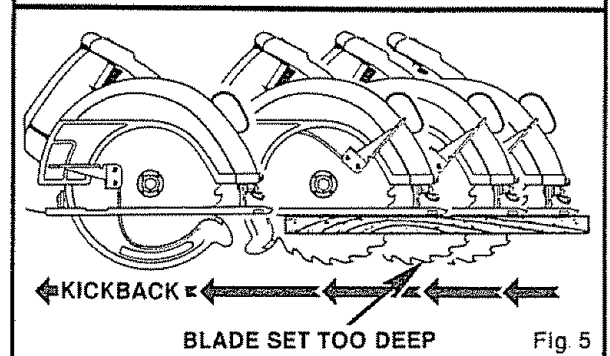
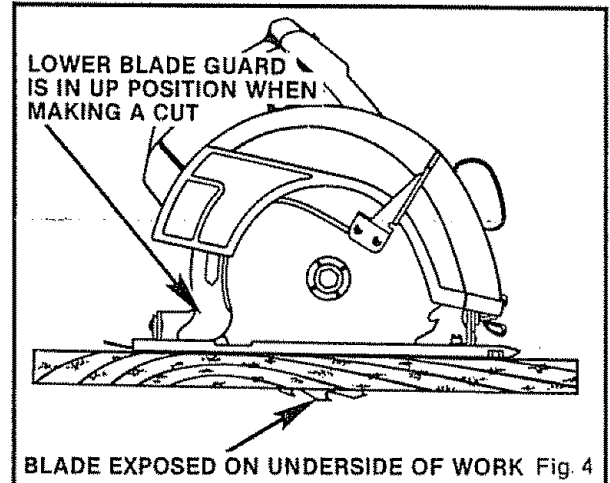

OPERATION

TO LESSEN THE CHANCE OF KICKBACK:

- 1 Always keep the correct blade depth setting – the correct blade depth setting for all cuts should not exceed 1/4" below the material to be cut. See Figure 7
- 2 Inspect the work for knots or nails before beginning a cut. Never saw into a knot or nail.
- 3 Make straight cuts. Always use a straight edge guide when rip cutting. This helps prevent twisting the blade in the cut.
- 4 Always use clean, sharp and properly set blades. Never make cuts with dull blades.
- 5 To avoid pinching the blade, support the work properly before beginning a cut. The right and wrong ways to support large pieces of work are shown in figure 6
- 6 When making a cut use steady, even pressure. Never force cuts.
- 7 Do not cut warped or wet lumber.
- 8 Always hold your saw firmly with both hands and keep your body in a balanced position so as to resist the forces of kickback should it occur.

WHEN USING YOUR SAW ALWAYS STAY ALERT AND EXERCISE CONTROL. DO NOT REMOVE YOUR SAW FROM WORKPIECE WHILE THE BLADE IS MOVING.

DEPTH OF CUT ADJUSTMENT

Always keep correct blade depth setting. The correct blade depth setting for all cuts should not exceed 1/4" below the material to be cut. More blade depth will increase the chance of kickback and cause the cut to be rough.

TO ADJUST BLADE DEPTH

1. Unplug your saw.

WARNING: FAILURE TO UNPLUG YOUR SAW COULD RESULT IN ACCIDENTAL STARTING CAUSING POSSIBLE SERIOUS PERSONAL INJURY.

2. Loosen wing nut. See Figure 8.
3. Hold base flat against the work and raise or lower saw until the required depth is reached.
4. Tighten wing nut securely.

STARTING A CUT

KNOW THE RIGHT WAY TO USE YOUR SAW.

See Figure 9.

NEVER USE YOUR SAW AS SHOWN IN FIGURE 10.

NEVER PLACE YOUR HAND ON THE WORKPIECE BEHIND YOUR SAW WHILE MAKING A CUT.

WARNING: TO MAKE SAWING EASIER AND SAFER, ALWAYS MAINTAIN PROPER CONTROL OF YOUR SAW. LOSS OF CONTROL OF YOUR SAW COULD CAUSE AN ACCIDENT RESULTING IN POSSIBLE SERIOUS INJURY.

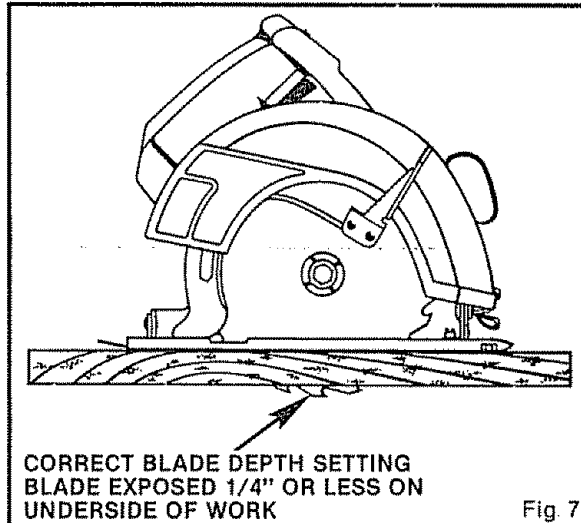

Fig 7

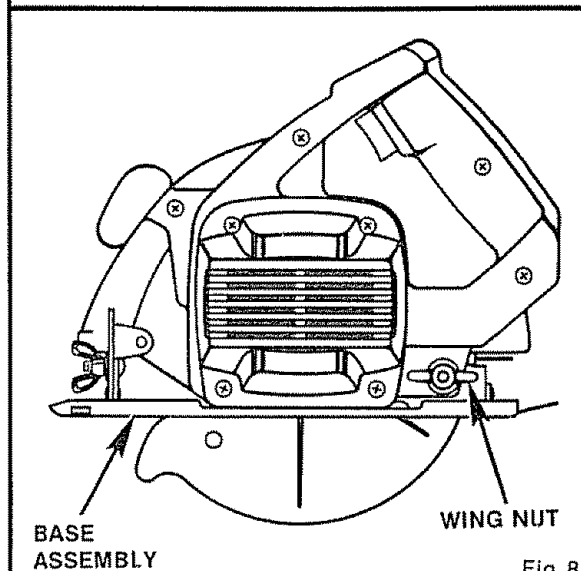

Fig 8

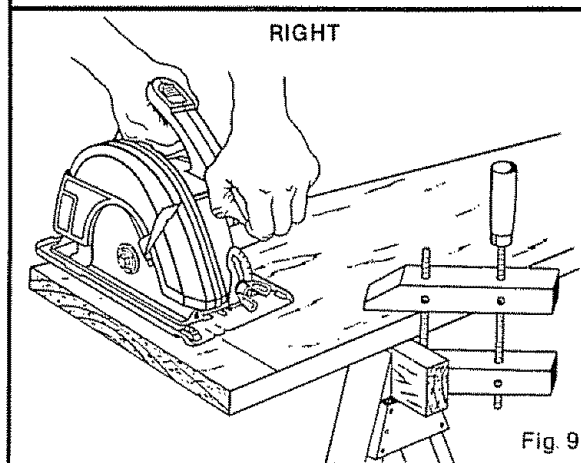

Fig 9

OPERATION

TO HELP MAINTAIN CONTROL:

- 1 Always support your work near the cut.
- 2 Support your work so the cut will be on your right.
- 3 Clamp your work so it will not move during the cut

Place your work with its good side down. **NOTE:** The good side is the side on which appearance is important.

Before beginning a cut, draw a guide line along the desired line of cut. Then place front edge of base on that part of your work that is solidly supported. See Figure 9.

NEVER PLACE YOUR SAW ON THAT PART OF THE WORK THAT WILL FALL OFF WHEN THE CUT IS MADE. See Figure 11.

Keep the cord away from cutting area. **ALWAYS** place the cord to prevent it from hanging up on the work while making a cut.

DANGER: IF THE CORD HANGS UP ON THE WORK DURING A CUT, RELEASE THE SWITCH TRIGGER IMMEDIATELY. UNPLUG YOUR SAW AND REPOSITION THE CORD TO PREVENT IT FROM HANGING UP AGAIN.

DANGER: USING YOUR SAW WITH A DAMAGED CORD COULD RESULT IN SERIOUS INJURY OR DEATH. IF THE CORD HAS BEEN DAMAGED, HAVE IT REPLACED BEFORE USING YOUR SAW AGAIN.

Hold your saw firmly with both hands. See Figure 12. Push the lock-off button and squeeze the switch trigger.

NOTE: The lock-off button is located on top of the handle.

ALWAYS let the blade reach full speed, then guide your saw into the work.

WARNING: THE BLADE COMING IN CONTACT WITH THE WORK BEFORE IT REACHES FULL SPEED COULD CAUSE YOUR SAW TO "KICKBACK" TOWARDS YOU RESULTING IN SERIOUS INJURY.

When making a cut use steady, even pressure. Forcing causes rough cuts, could shorten the life of your saw and could cause "kickback."

REMEMBER:

When sawing through work, the lower blade guard does not cover the blade, exposing it on the underside of work. Keep your hands and fingers away from cutting area. Any part of your body coming in contact with the moving blade will result in serious injury.

After you complete your cut release the trigger and allow the blade to come to a complete stop. **DO NOT REMOVE YOUR SAW FROM WORKPIECE WHILE THE BLADE IS MOVING.**

CAUTION: When lifting your saw from the work the blade is exposed on the underside of your saw until the lower blade guard closes. Make sure lower blade guard is closed before setting your saw down on work surface.

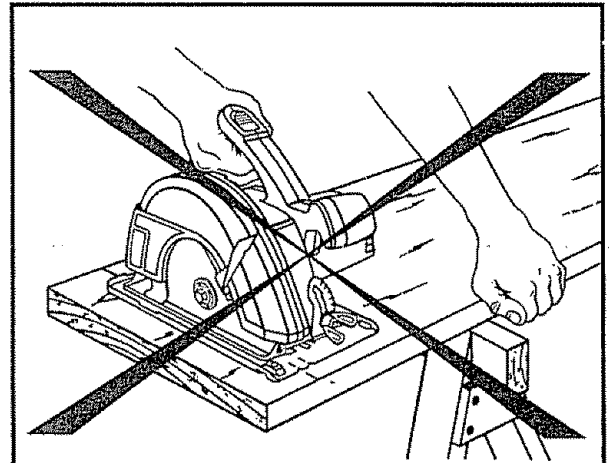

WRONG

Fig 10

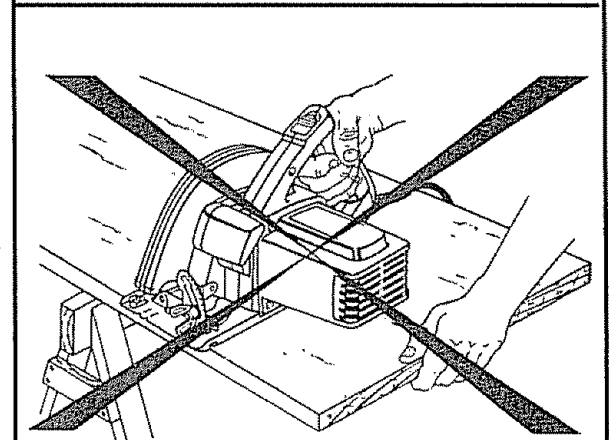

WRONG

Fig 11

LOCK-OFF BUTTON

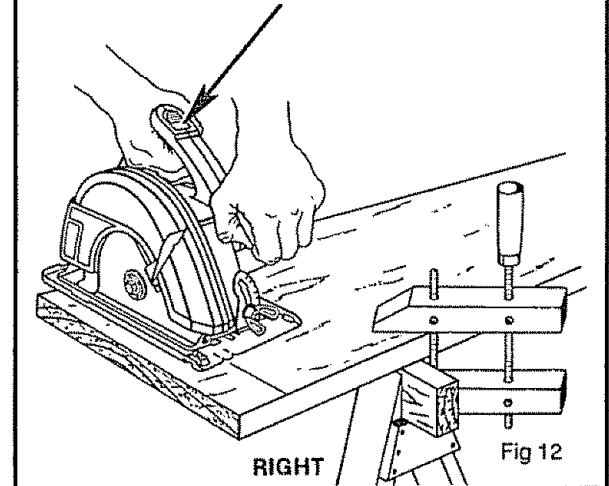

RIGHT

Fig 12

OPERATION

TO CROSS CUT OR RIP CUT

When making a cross cut or rip cut, align your line of cut with the outer blade guide notch on the saw base as shown in figure 13. Since blade thicknesses vary, always make a trial cut in scrap material along a guideline to determine how much, if any, the guideline must be offset to produce an accurate cut. **NOTE:** The distance from the line of cut to the guideline is the amount you should offset the guideline.

EDGE GUIDE (RIP GUIDE)

Use a rip guide when making rip cuts up to five inches wide. It helps prevent the blade from twisting in a cut. The blade twisting in a cut can cause kickback. Rip Guide Cat No. 9-27679 is available at your Sears Catalog Order or Retail Store.

TO ASSEMBLE RIP GUIDE

1. Unplug your saw.

WARNING: FAILURE TO UNPLUG YOUR SAW COULD RESULT IN ACCIDENTAL STARTING CAUSING POSSIBLE SERIOUS PERSONAL INJURY.

2. Place rip guide through holes in saw base as shown in figure 14.
3. Adjust rip guide to the length needed for the cut.
4. Tighten edge guide screw securely.

When using a rip guide, hold the face of the rip guide firmly against the edge of work. This makes for a true cut without pinching the blade. The guiding edge of work must be straight for your cut to be straight. Use caution to prevent the blade from binding in the cut.

TO BEVEL CUT

The angle of cut of your saw may be adjusted to any desired setting between zero and 51.5°. **NOTE:** When making cuts at 51.5° blade should be set at full depth of cut, with edge guide screw removed.

When making 45° bevel cuts, there is a notch in the saw base to help you line up the blade with the line of cut. See Figure 15. Align your line of cut with the inner blade guide notch on the saw base when making 45° bevel cuts. Since blade thicknesses vary and different angles require different settings, always make a trial cut in scrap material along a guideline to determine how much you should offset the guideline on the board to be cut.

When making a bevel cut hold your saw firmly with both hands as shown in figure 16. Rest the front edge of the base on the work. Push in the lock-off button and squeeze the switch trigger. **ALWAYS** let the blade reach full speed, then guide your saw into the work.

WARNING: THE BLADE COMING IN CONTACT WITH THE WORK BEFORE IT REACHES FULL SPEED COULD CAUSE SAW TO "KICKBACK" TOWARD YOU RESULTING IN SERIOUS INJURY.

After you complete your cut release the trigger and allow the blade to come to a complete stop. **AFTER** the blade has stopped, lift your saw from the work.

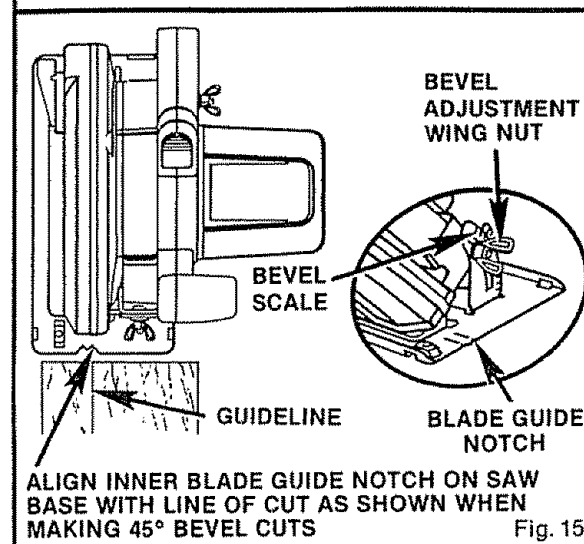
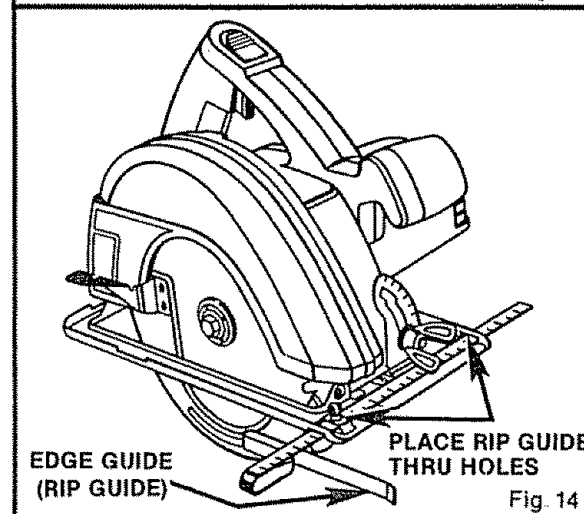
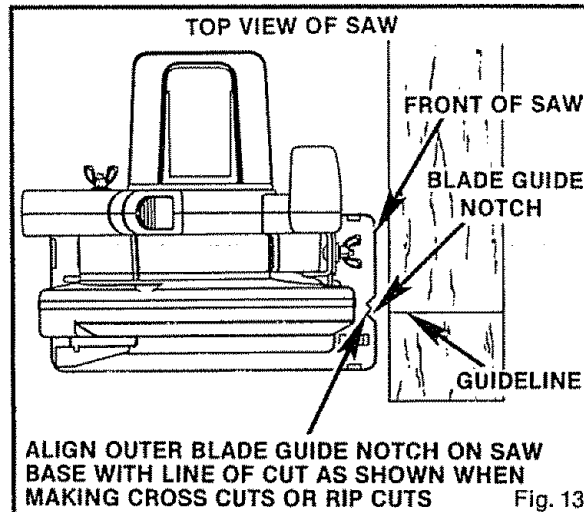

OPERATION

TO ADJUST BEVEL SETTING

1. Unplug your saw.

WARNING: FAILURE TO UNPLUG YOUR SAW COULD RESULT IN ACCIDENTAL STARTING CAUSING POSSIBLE SERIOUS PERSONAL INJURY.

2. Loosen wing nut. *See Figure 15.*
3. Raise motor housing end of saw until you reach desired angle setting on bevel scale. *See Figure 15.*
4. Tighten wing nut securely.

WARNING: ATTEMPTING BEVEL CUT WITHOUT WING NUT SECURELY TIGHTENED CAN RESULT IN SERIOUS INJURY.

POSITIVE 0° BEVEL STOP

See Figure 17.

Your saw has a positive 0° bevel stop, that has been factory adjusted to assure 0° angle of your saw blade when making 90° cuts. However, misalignment can occur during shipping.

TO CHECK

1. Unplug your saw.

WARNING: FAILURE TO UNPLUG YOUR SAW COULD RESULT IN ACCIDENTAL STARTING CAUSING POSSIBLE SERIOUS PERSONAL INJURY.

2. Place your saw in an upside down position on workbench. *See Figure 17.*
3. Using a carpenter's square, check squareness of saw blade to the base of your saw.

TO ADJUST

1. Unplug your saw.

WARNING: FAILURE TO UNPLUG YOUR SAW COULD RESULT IN ACCIDENTAL STARTING CAUSING POSSIBLE SERIOUS PERSONAL INJURY.

2. Loosen wing nut
3. Loosen hex nut securing adjustment screw.
4. Turn screw and adjust base until square with saw blade
5. Tighten hex nut and wing nut securely

WARNING: ATTEMPTING TO MAKE CUTS WITHOUT WING NUT SECURELY TIGHTENED CAN RESULT IN SERIOUS INJURY.

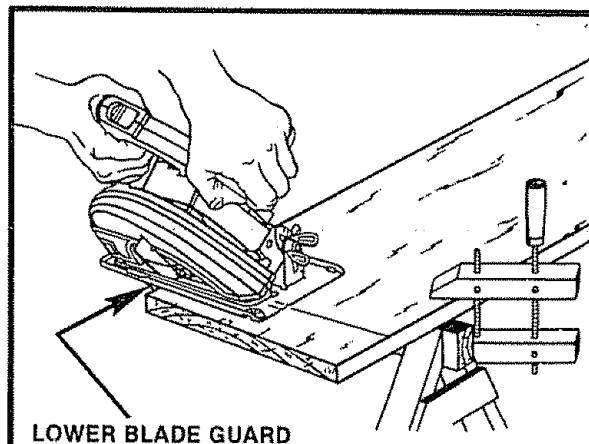

Fig 16

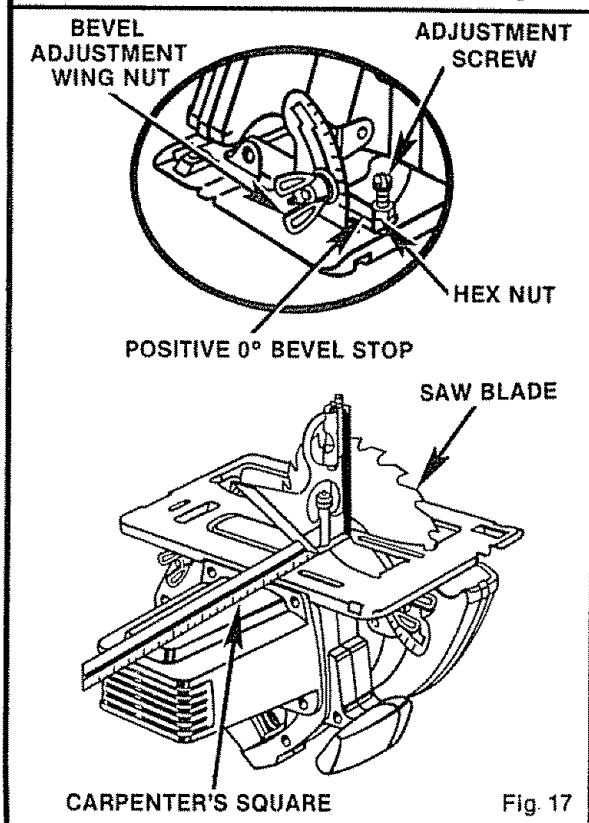

Fig. 17

OPERATION

TO POCKET CUT

See Figure 18.

WARNING: ALWAYS ADJUST BEVEL SETTING TO ZERO BEFORE MAKING A POCKET CUT. ATTEMPTING A POCKET CUT AT ANY OTHER SETTING CAN RESULT IN LOSS OF CONTROL OF YOUR SAW POSSIBLY CAUSING SERIOUS INJURY.

Adjust the bevel setting to zero and swing the lower blade guard up using the lower blade guard handle **ALWAYS RAISE THE LOWER BLADE GUARD WITH THE HANDLE TO AVOID SERIOUS INJURY.** While holding lower blade guard by the handle, firmly rest the front of the base flat against the workpiece with the rear of the handle raised so the blade does not touch the work. See Figure 18. Push the lock-off button down and squeeze the switch trigger.

ALWAYS LET THE BLADE REACH FULL SPEED THEN SLOWLY LOWER BLADE INTO THE WORK UNTIL BASE IS FLAT AGAINST WORK. After you complete your cut release the trigger and allow the blade to come to a complete stop. After the blade has stopped, remove it from the work. Corners may then be cleared out with a hand saw or sabre saw.

WARNING: NEVER TIE THE LOWER BLADE GUARD IN A RAISED POSITION. LEAVING THE BLADE EXPOSED COULD LEAD TO SERIOUS INJURY.

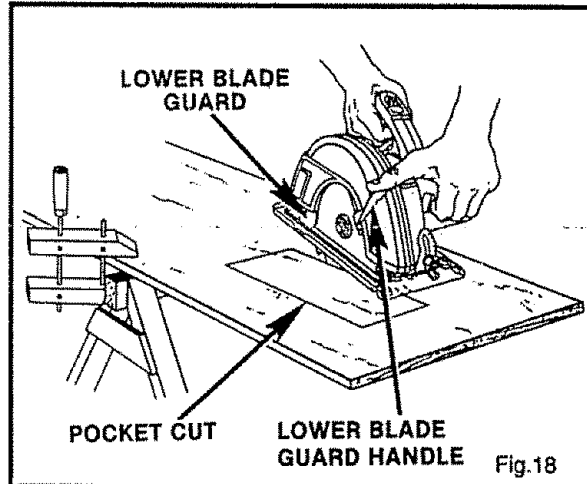

THE FOLLOWING RECOMMENDED ACCESSORIES ARE CURRENT AND WERE AVAILABLE AT THE TIME THIS MANUAL WAS PRINTED.

Carrying Case (9-14705)	7 1/4" Saw Blade (9-32141)
Rip Guide (9-27679)	7 1/4" Saw Blade (9-32134)
50' 14 A.W.G. Ext. Cord (9-5821)	7 1/4" Saw Blade (9-32149)
100' 14 A.W.G. Ext. Cord (9-83508)	7 1/4" Saw Blade (9-32526)
7 1/4" Saw Blade (9-32174)	7 1/4" Saw Blade (9-32518)
7 1/4" Saw Blade (9-32162)	7 1/4" Saw Blade (9-32489)
7 1/4" Saw Blade (9-32122)	

WARNING: The use of attachments or accessories not listed above might be hazardous.

MAINTENANCE

WARNING: WHEN SERVICING USE ONLY IDENTICAL CRAFTSMAN REPLACEMENT PARTS. USE OF ANY OTHER PARTS MAY CREATE A HAZARD OR CAUSE PRODUCT DAMAGE.

GENERAL

Only the parts shown on parts list, page fifteen, are intended to be repaired or replaced by the customer. All other parts represent an important part of the double insulation system and should be serviced only by a qualified Sears service technician.

Avoid using solvents when cleaning plastic parts. Most plastics are susceptible to various types of commercial solvents and may be damaged by their use. Use clean cloths to remove dirt, carbon dust, etc.

WARNING: DO NOT AT ANY TIME LET BRAKE FLUIDS, GASOLINE, PETROLEUM-BASED PRODUCTS, PENETRATING OILS, ETC. COME IN CONTACT WITH PLASTIC PARTS. THEY CONTAIN CHEMICALS THAT CAN DAMAGE, WEAKEN, OR DESTROY PLASTIC.

When electric tools are used on fiberglass boats, sports cars, wallboard, spackling compounds, or plaster, it has been found that they are subject to accelerated wear and possible premature failure, as the fiberglass chips and grindings are highly abrasive to bearings, brushes, commutator, etc. Consequently it is not recommended that this tool be used for extended work on any fiberglass material, wallboard, spackling compounds, or plaster. During any use on fiberglass it is extremely important that the tool is cleaned frequently by blowing with an air jet. **ALWAYS WEAR SAFETY GOGGLES, SAFETY GLASSES WITH SIDE SHIELDS, OR A DUST MASK DURING POWER TOOL OPERATION OR WHEN BLOWING DUST.**

LUBRICATION

All of the bearings in this tool are lubricated with a sufficient amount of high grade lubricant for the life of the unit under normal operating conditions. Therefore, no further lubrication is required.

EXTENSION CORDS

The use of any extension cord will cause some loss of power. To keep the loss to a minimum and to prevent tool overheating, use an extension cord that is heavy enough to carry the current the tool will draw. Follow the recommended cord sizes on the chart provided to determine the minimum wire size required in an extension cord.

Extension Cord Length	Wire Gauge Size (A.W.G.)
25-50 Feet	16
50-100 Feet	14

When working with your tool outdoors, use an extension cord suitable for outdoor use and so marked. Outdoor use extension cords are marked with the letters "WA" on the cord's jacket.

CAUTION: Keep extension cords away from the cutting area and position the cord so that it will not get caught on lumber, tools, etc., during cutting.

WARNING: CHECK EXTENSION CORDS BEFORE EACH USE. IF DAMAGED REPLACE IMMEDIATELY. NEVER USE TOOL WITH A DAMAGED CORD SINCE TOUCHING THE DAMAGED AREA COULD CAUSE ELECTRICAL SHOCK RESULTING IN SERIOUS INJURY.

Extension cords suitable for use with your circular saw are available at your nearest Sears Catalog Order or Retail Store.

CRAFTSMAN CIRCULAR SAW - MODEL NUMBER 315.108240

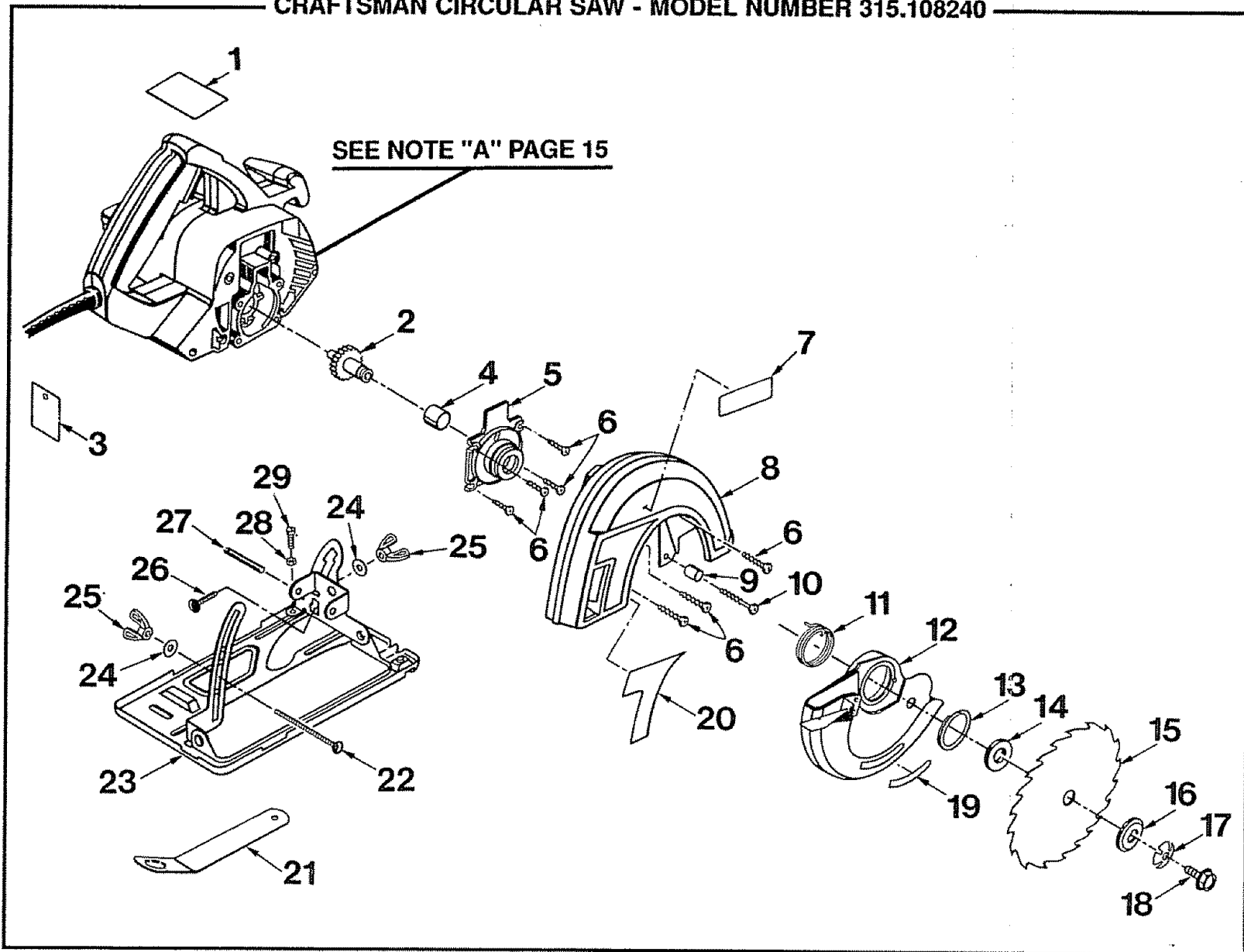

CRAFTSMAN CIRCULAR SAW- MODEL NUMBER 315.108240

The Model Number will be found on a plate attached to the Motor Housing. Always mention the Model Number in all correspondence regarding your **CIRCULAR SAW** or when ordering repair parts. Only the parts listed below are intended to be repaired or replaced.

SEE BACK PAGE FOR PARTS ORDERING INSTRUCTIONS

PARTS LIST

Key No.	Part Number	Description	Quan.	Key No.	Part Number	Description	Quan.
1	968424-001	Data Plate	1	16	998463-001	Outer Blade Washer	1
2	969058-001	Gear and Spindle	1	17	623547-002	Spring Washer	1
3	990147-001	Warning Tag	1	18	612999-001	Blade Screw	1
4	999637-003	Bearing	1	19	999988-001	Label	1
5	969373-002	Lower Blade Guard Support	1	20	968425-001	Logo Plate	1
6	968702-011	* Screw (#8-16 x 3/4" Pan Hd.)	7	21	967074-001	Wrench	1
7	969827-001	Logo Plate	1	22	621433-013	Carriage Bolt (#1/4-20 x 3-1/4")	1
8	968442-002	Fixed Blade Guard	1	23	969856-001	Base Assembly	1
9	968419-002	Bumper	1	24	931744-059	Washer	2
10	617524-004	* Screw (#10-16 x 1-3/4" Pan Hd.)	1	25	621438-006	Wing Nut **STD541625	2
11	967952-001	Torsion Spring	1	26	621433-001	Carriage Bolt (#1/4-20 x 5/8") **STD532507 ..	1
12	969855-001	Lower Blade Guard Assembly	1	27	941401-815	Roll Pin	1
13	718602-804	Retaining Ring	1	28	706404-007	Hex Nut (#8-32) **STD541008	1
14	999982-001	Inner Blade Washer	1	29	703432-058	* Screw (#8-32 x 5/8" Fil. Hd.)	1
15	***	Saw Blade 7-1/4" for 5/8" Arbor			612547-654	Owner's Manual	

NOTE: "A"— The assembly shown represents an important part of the Double Insulated System. To avoid the possibility of alteration or damage to the system, service should be performed by your nearest Sears Repair Center. Contact your nearest Sears Catalog Order or Retail Store.

- * Standard Hardware Item — May Be Purchased Locally
- ** Available From Div.98 — Source 980.00
- *** Complete Assortment Available At Your Nearest Sears Catalog Order or Retail Store

SEARS

OWNER'S
MANUAL

SERVICE

MODEL NO.
315.108240

HOW TO ORDER
REPAIR PARTS

CRAFTSMAN[®]

7-1/4 INCH
CIRCULAR SAW
DOUBLE INSULATED

Now that you have purchased your Circular Saw, should a need ever exist for repair parts or service, simply contact any Sears Service Center and most Sears, Roebuck and Co. stores. Be sure to provide all pertinent facts when you call or visit.

The model number of your Circular Saw will be found on a plate attached to the motor housing.

WHEN ORDERING REPAIR PARTS, ALWAYS GIVE THE FOLLOWING INFORMATION:

- | | |
|------------------------------|--------------------------------|
| • PART NUMBER | • PART DESCRIPTION |
| • MODEL NUMBER
315.108240 | • NAME OF ITEM
Circular Saw |

All parts listed may be ordered from any Sears Service Center and most Sears stores.

If the parts you need are not stocked locally, your order will be electronically transmitted to a Sears Repair Parts Distribution Center for handling.