

IMPORTANT MANUAL

Do Not Throw Away

SEARS

**Operator's
Manual**

**Model No.
358.795620**

▲ WARNING:

**Read the Operator's Manual and
Follow All Warnings and Safety
Instructions. Failure To Do So
Can Result in Serious Injury.**

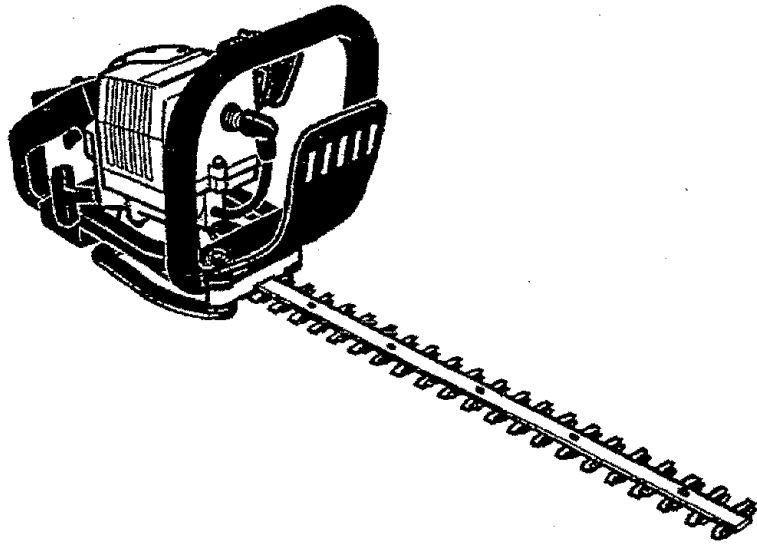

Always Wear Eye Protection

SEARS/CRAFTSMAN®

GASOLINE HEDGE TRIMMER

- Assembly
- Maintenance
- Operation
- Repair Parts

Sears, Roebuck and Co., Hoffman Estates, IL 60179 USA

FULL ONE-YEAR WARRANTY ON CRAFTSMAN HEDGE TRIMMER

If this Craftsman Hedge Trimmer fails to give complete satisfaction within one year from the date of purchase, RETURN IT TO (OR CONTACT) THE NEAREST SEARS SERVICE CENTER/DEPARTMENT IN THE UNITED STATES and Sears will repair it free of charge.

If this Hedge Trimmer is used for commercial or rental purposes, this warranty applies for only 30 days from the date of purchase.

This warranty gives you specific legal rights and you may also have other rights which vary from state to state.

SEARS, ROEBUCK AND CO., DEPT. 817WA, HOFFMAN ESTATES, IL 60179

TABLE OF CONTENTS

WARNINGS AND SAFETY INSTRUCTIONS .. 3	USING YOUR UNIT 8
KNOW YOUR UNIT 5	CUSTOMER RESPONSIBILITY --
ENGINE INFORMATION 6	GENERAL MAINTENANCE 10
ACCESSORIES/MAINTENANCE ITEMS 7	PARTS AND SERVICE Back Cover

SPECIFICATIONS

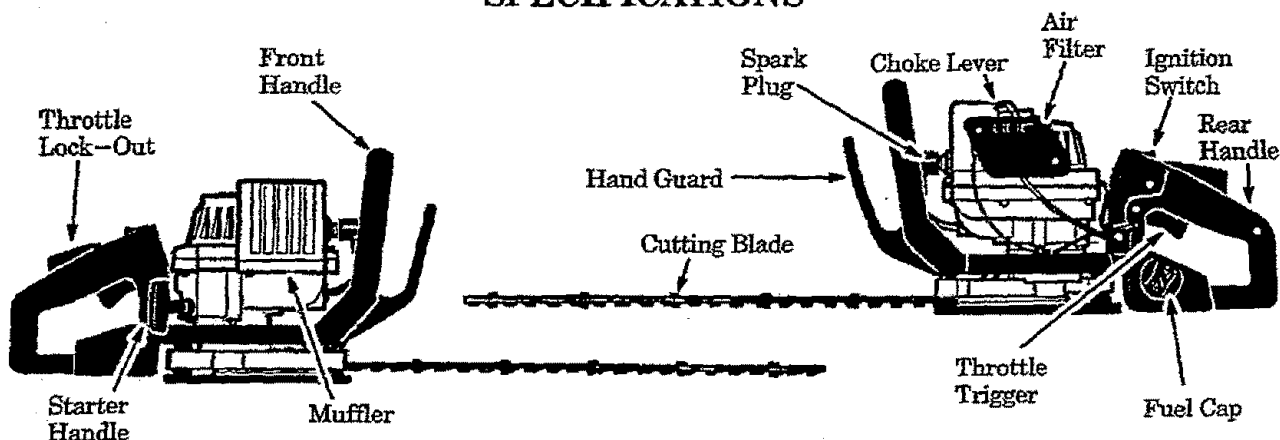





MODEL:	358.795620
ENGINE:	2-cycle, Air Cooled
DISPLACEMENT:	21cc
ENGINE RPM:	Operating -- 9000 Idle -- 2600-3400
CUTTING BLADE:	22 Inches
SPARK PLUG	CHAMPION CY-8Y
SPARK PLUG GAP:	.024" to .028"
IGNITION:	Solid State
MODULE AIR GAP:	.010" to .014"
FUEL MIX:	Gasoline/Oil Mixture 40:1 (see Fueling Your Engine)
MUFFLER:	Lo Tone (Spark Arresting)
FUEL TANK CAPACITY:	207 cc (7 fl. oz.)

Manufactured under U.S. patent #4,940,020. Other U.S. and foreign patents pending.

▲ WARNINGS AND SAFETY INSTRUCTIONS

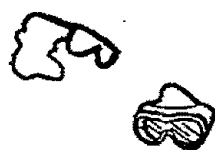
(See Additional Safety Instructions throughout this Manual)

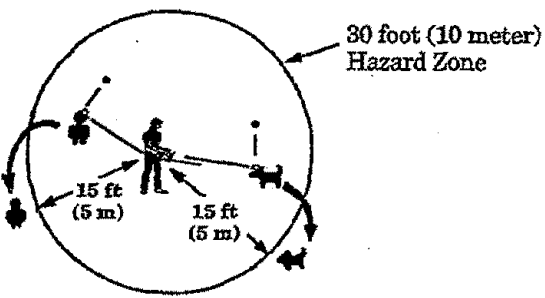
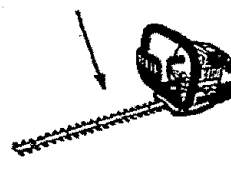
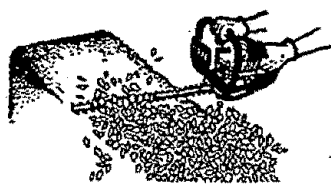
▲ DANGER – THIS POWER TOOL CAN BE DANGEROUS! This unit can cause serious injury including amputation or blindness to the operator and others. The warnings and safety instructions in this manual must be followed to provide reasonable safety and efficiency in using this unit. The operator is responsible for following the warnings and instructions in this manual and on the unit. Read the entire Operator's Manual before assembling and using this unit! Restrict the use of this power tool to persons who read, understand, and follow the warnings and instructions in this manual and on the unit.

<p>Always Wear Eye Protection</p> 	 <p>Eye Protection</p>	<p>▲ WARNING CUTTING BLADE CAN THROW OBJECTS VIOLENTLY.</p> <ul style="list-style-type: none"> - YOU CAN BE BLINDED OR INJURED. - ALWAYS WEAR EYE PROTECTION.
 <p>30 foot (10 meter) Hazard Zone</p> <p>15 ft (5 m)</p> <p>15 ft (5 m)</p>		<p>▲ WARNING HAZARD ZONE FOR CUTTING BLADE</p> <ul style="list-style-type: none"> - THE CUTTING BLADE CAN SERIOUSLY CUT YOU OR OTHERS. - OTHERS CAN BE BLINDED OR INJURED. - KEEP PEOPLE AND ANIMALS 15 FEET (5 METERS) AWAY.
<p>BLADE MOVES MOMENTARILY AFTER TRIGGER IS RELEASED.</p> 	<p>ALLOW CUTTING BLADE TO STOP BEFORE REMOVING IT FROM THE CUT.</p> 	<p>▲ WARNING BLADE MOVES MOMENTARILY AFTER TRIGGER IS RELEASED.</p> <ul style="list-style-type: none"> - THE CUTTING BLADE CAN SERIOUSLY CUT YOU OR OTHERS. - ALLOW CUTTING BLADE TO STOP BEFORE REMOVING IT FROM THE CUT.
 <p>Operator's Manual</p>	 <p>Safety Labels</p>	<p>▲ WARNING READ OPERATOR'S MANUAL.</p> <ul style="list-style-type: none"> - FOLLOW ALL WARNINGS AND INSTRUCTIONS. - FAILURE TO DO SO CAN RESULT IN SERIOUS INJURY.

WARNINGS AND SAFETY INSTRUCTIONS...(Continued)

▲ OPERATOR SAFETY

1. **DRESS PROPERLY**--Always wear eye protection when operating, servicing, or performing maintenance on your unit. Always wear heavy, long pants, boots, and gloves. Do not go barefoot or wear short pants, sandals, jewelry, loose clothing, or clothing with loosely hanging straps, ties, tassels, etc.; they can be caught in moving parts. Secure hair so it is above shoulder length. Being fully covered will help protect you from pieces of toxic plants such as poison ivy thrown by the cutting blade, which could be more of a hazard than touching the plant itself.
2. **STAY ALERT**--Do not operate the unit when you are tired, ill, or under the influence of alcohol, drugs, or medication.
3. **DANGER--RISK OF CUT--KEEP HANDS AWAY FROM BLADE**--Do not attempt to clear away cut material when the blade is in motion. Make sure the switch is in the STOP position, the spark plug wire is disconnected, and the blade has stopped moving before removing jammed material from the cutting blade. Do not grab or hold the unit by the cutting blade.
4. **WARNING**--blade moves momentarily after the trigger is released.
5. Wear hearing protection when using this unit.

▲ UNIT SAFETY

1. Inspect entire unit before each use. Always make sure all handles and guards are properly and securely fastened when using the unit. Have damaged parts replaced by your SEARS Service Center/Department. Make sure all fasteners are in place and securely fastened.
2. Do not use a cutting blade that is bent, warped, cracked, broken, or damaged in any other way. Have parts that are cracked, chipped, broken, or damaged in any other way replaced by your SEARS Service Center/Department before using the unit.
3. Use only SEARS cutting blades.
4. Use only genuine SEARS accessories as recommended for this unit.

▲ FUEL SAFETY

1. Mix and pour fuel outdoors and where there are no sparks or flames.
2. Use a container approved for fuel.
3. Do not smoke or allow smoking near fuel or the unit or while using the unit.
4. Wipe up all fuel spills before starting engine.
5. Move at least 10 feet (3 meters) away from fueling site before starting engine.
6. Stop engine before removing fuel cap. Allow engine to cool before refueling.

If situations occur which are not covered in this manual, use care and good judgment. Contact your SEARS Service Center/Department if you need assistance.

7. Empty the fuel tank before storing the unit. Use up fuel left in the carburetor by starting the engine and letting the engine run until it stops.
8. Store unit and fuel in an area where fuel vapors cannot reach sparks or open flames from water heaters, electric motors or switches, furnaces, etc.

▲ TRIMMING SAFETY

1. Inspect the area to be trimmed before each use. Remove objects (rocks, broken glass, nails, wire, string, etc.) which can wrap around or be thrown by the cutting blade.
2. **KEEP CHILDREN AWAY**--Keep others including children, animals, bystanders and helpers outside the 30 foot (10 meter) Hazard Zone. Stop the unit immediately if you are approached.
3. Always keep the unit in front of your body.
4. **DON'T OVERREACH OR STAND ON UNSTABLE SUPPORT**--Keep firm footing and balance at all times.
5. Do not raise the unit above your shoulders. The cutting blade can come dangerously close to your body.
6. Keep all parts of your body away from the cutting blade.
7. **USE UNIT PROPERLY**--Use only for jobs explained in this manual.

▲ MAINTENANCE SAFETY

1. **MAINTAIN UNIT WITH CARE**--Maintain the unit according to recommended procedures.
2. Keep the cutting blade and air vents free of debris.
3. **DISCONNECT THE SPARK PLUG** before performing maintenance.
4. Use only genuine SEARS replacement parts as recommended.
5. Have all maintenance and service not explained in this manual performed by your SEARS Service Center/Department.

▲ TRANSPORTING AND STORAGE

1. Hand carry the unit with the engine stopped and the muffler and cutting blade away from your body.
2. Allow the engine to cool, empty the fuel tank, and secure the unit before storing or transporting it in a vehicle.
3. Empty the fuel tank before storing the unit. Use up fuel left in the carburetor by starting the engine and letting the engine run until it stops.
4. Store the unit and fuel in an area where fuel vapors cannot reach sparks or open flames from water heaters, electric motors or switches, furnaces, etc.
6. Store unit so the cutting blade cannot accidentally cause injury. The unit can be hung by the handle.
7. **STORE UNIT INDOORS**--Store the unit in a cool, dry place out of the reach of children.

SAFETY NOTICE

Exposure to vibrations through prolonged use of gasoline powered hand tools could cause blood vessel or nerve damage in the fingers, hands, and wrists of people prone to circulation disorders or abnormal swellings. Prolonged use in cold weather has been linked to blood vessel damage in otherwise healthy people. If symptoms occur such as numbness, pain, loss of strength, change in skin color or texture, or loss of feeling in the fingers, hands, or wrists, discontinue the use of this tool and seek medical attention. An anti-vibration system does not guarantee the avoidance of these problems. Users who operate power tools on a continual and regular basis must monitor closely their physical condition and the condition of this tool.

KNOW YOUR UNIT

A. INTRODUCTION

Your unit will trim hedges precisely and neatly.

Special Features Include:

- 21cc (1.28 cu. in.) Engine
- Handguard
- Comfortable Front Handle
- Throttle Trigger Lock-out
- Anti-vibration Handles

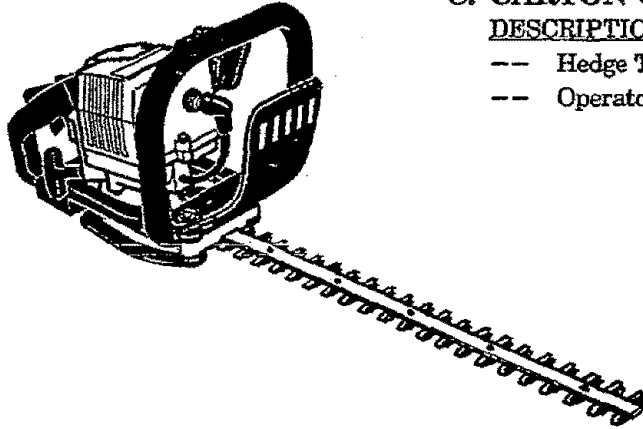

B. UNPACKING INSTRUCTIONS

1. After removing the contents from the carton, check the parts against the adjacent list.
2. Examine the parts for damage. Do not use damaged parts.
3. *Notify your SEARS Store immediately if a part is missing or damaged.*

C. CARTON CONTENTS

<u>DESCRIPTION</u>	<u>QTY.</u>
-- Hedge Trimmer	1
-- Operator's Manual (not shown)	1

PRE-OPERATION CHECKS

This Operator's Manual is designed to help you safely operate and maintain your unit. It is important that you read the entire manual to become familiar with the unit *before* you begin operation.

▲ WARNING

Review all Warnings and Safety Instructions in this manual.

Before operating your unit, always:

- a. **Inspect the entire unit before each use.** Replace damaged parts.
- b. **Use only the specified cutting blade.** See "Specifications." Make sure the cutting blade is properly installed and securely fastened.
- c. **Have your SEARS Service Center/Department replace cutting blades that are bent, warped, cracked, broken, or damaged in any other way before using the unit.**
- d. **Use only SEARS cutting blades.**
- e. **Use only genuine SEARS accessories or attachments as recommended for this unit.**

SPECIAL NOTICE

For users on U.S. Forest Land and in some states, including California (Public Resources Codes 4442 and 4443), Idaho, Maine, Minnesota, New Jersey, Oregon, and Washington: Certain internal combustion engines operated on forest, brush, and/or grass-covered lands, in the above areas, must be equipped with a spark arrestor, maintained in effective working order, or the engine must be constructed, equipped, and maintained for the prevention of fire. Check with your state or local authorities for regulations pertaining to these requirements. Failure to follow these requirements is a violation of the law. **This unit is factory-equipped with a spark arrestor.** If a spark arrestor is required in your area, you are legally responsible for maintaining the operating condition of these parts.

ENGINE INFORMATION

A. BEFORE STARTING YOUR ENGINE



WARNING:

BE SURE TO READ THE FUEL SAFETY INFORMATION IN THE SAFETY RULES SECTION ON PAGE 4 OF THIS MANUAL BEFORE YOU BEGIN.

IF YOU DO NOT UNDERSTAND THE FUEL SAFETY SECTION DO NOT ATTEMPT TO FUEL YOUR UNIT; SEEK HELP FROM SOMEONE THAT DOES UNDERSTAND THE FUEL SAFETY SECTION OR CALL THE CUSTOMER ASSISTANCE HOTLINE AT 1-800-235-5878.

GASOLINE

The two-cycle engine on this product requires a fuel mixture of regular unleaded gasoline and a high quality 2-cycle engine oil (AIR-COOLED) for lubrication of the bearings and other moving parts. The correct fuel/oil mixture is 40:1 (see Fuel Mixture Chart). Too little oil or the incorrect oil type will cause poor performance and may cause the engine to overheat and seize.

Gasoline and oil must be premixed in a clean approved fuel container. Always use fresh regular unleaded gasoline.

IMPORTANT: Experience indicates that alcohol blended fuels called gasohol (or using ethanol or methanol) can attract moisture, which leads to oil/gas separation and formation of acids during storage. Acidic gas can damage the fuel system of an engine while in storage. To avoid engine problems, the fuel system should be emptied before storage for 30 days or longer. Drain the gas tank, then run the fuel out of the carburetor and fuel lines by starting the engine and letting it run until it stops. Use fresh fuel next season. See STORAGE instructions for additional information. Never use engine or carburetor cleaner products in the fuel tank or permanent damage may occur.

FUEL STABILIZER

Fuel stabilizer is an acceptable alternative in minimizing the formation of fuel gum deposits during storage. Add stabilizer to gasoline in fuel tank or storage container. Always follow the fuel mix ratio found on the stabilizer container. Run engine at least 5 minutes after adding stabilizer to allow the stabilizer to reach the carburetor. You do not have to drain the fuel tank for storage if you are using fuel stabilizer.

CRAFTSMAN 40:1 2 cycle engine oil is specially blended with fuel stabilizers. If you do not use this Sears oil, you can add a fuel stabilizer (such as Craftsman No. 33500) to your fuel tank.

CRAFTSMAN 40:1 2 cycle oil is strongly recommended. This oil is specially blended with fuel stabilizers for

increased fuel stability (extends fuel life up to 5 times longer) and reduced smoke.

If CRAFTSMAN 2 cycle oil is not available, use a good quality 2 cycle AIR-COOLED engine oil that has a recommended fuel mix 40:1.

IMPORTANT! Do not use:

- AUTOMOTIVE OIL
- BOAT OILS (NMMA, BIA, etc.)

These oils do not have proper additives for 2-cycle, AIR-COOLED engines and can cause engine damage.

GASOLINE AND OIL MIXTURE

Mix gasoline and oil as follows:

- Consult chart for correct quantities.
- Do not mix gasoline and oil directly in the fuel tank.

FOR ONE GALLON:

- Pour 3.2 ounces of high quality, 2-cycle engine oil into an empty, approved one gallon gasoline container.
- Add one gallon of regular unleaded gasoline to the gallon container, then securely replace the cap. Shake the container momentarily.
- The mixture is now ready for use. Fuel stabilizer can be added at this time if desired; follow mixing instructions on the label.

FUEL MIXTURE CHART

40:1 Fuel:Oil Mix Ratio

Gasoline	Oil (fl. oz.)
1 gallon	3.2
1.25 gallons	4.0
2.5 gallons	8.0

NOTE: One gallon fuel containers can hold more than one gallon.

B. STARTING INSTRUCTIONS

(For location of controls, refer to "Specifications.")

1. Before starting the engine:

- Fuel engine. Move 10 feet (3 meters) away from fueling site.
- Rest engine on the ground. Support the unit so the blade is off of the ground and away from trees, bushes, onlookers, etc. Figure 1.
- Start engine before lifting unit to operating position.

2. For a cold engine or a warm engine after running out of fuel:

- Move ignition switch to "RUN." Figure 2.
- Move choke to the "FULL" position. Figure 3.
- Push down the throttle lock-out, squeeze the throttle trigger fully, press and hold the throttle lock, then slowly release the throttle trigger. Figure 2. *Keep the throttle lock engaged until the engine runs smoothly (through step "g.")*
- Pull starter rope sharply until engine attempts to run, but no more than 8 pulls at full choke to avoid flooding the engine. *The "attempt to run" may be hard to hear. The operator must listen carefully.* After 8 pulls, proceed to step "e." even if the engine has not attempted to run.
- Move choke to "HALF" position. Figure 3.
- Pull the starter rope sharply until the engine runs, but no more than 5 pulls.

NOTE: If the engine does not start after 5 pulls, repeat steps "a." through "f."

- Allow engine to run 5 seconds, then move choke to the "OFF" position. Figure 3. *Keep the throttle lock engaged until the engine runs smoothly.*
- After the engine begins to run smoothly, disengage the throttle lock by squeezing then releasing the throttle trigger.

NOTE: If engine dies with choke at the "OFF" position, repeat steps "e." through "g."

NOTE: If engine does not start, pull starter rope 5 more pulls. If engine still does not run, it is probably flooded. Wait a few minutes and repeat the procedure with choke at the "OFF" position. Figure 3.

▲ WARNING

Avoid any bodily contact with the muffler when starting a warm engine. A hot muffler can cause serious burns.

3. For a Warm Engine:

- Move kill switch to "RUN." Figure 2.
- Move choke to the "HALF" position. Figure 3.
- Squeeze throttle trigger fully and engage the throttle lock. Figure 2. *Keep the throttle lock engaged until the engine runs smoothly.*
- Pull starter rope sharply until engine runs, but no more than 5 pulls.
- Move choke to the "OFF" position. Figure 3.
- After the engine begins to run smoothly, disengage the throttle lock by squeezing then releasing the throttle trigger.

NOTE: If engine does not start after 5 pulls, it is probably flooded. Wait a few minutes and repeat procedure with choke at "OFF" position. Figure 3.

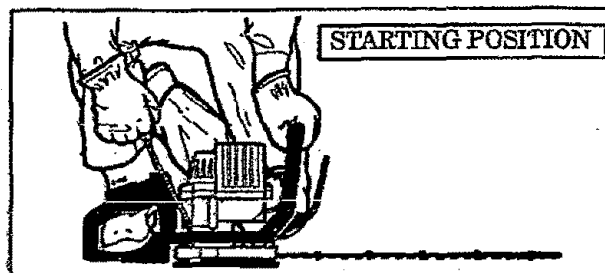

Figure 1

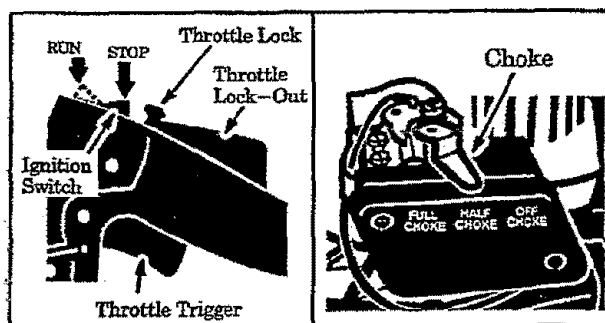

Figure 2

Figure 3

ACCESSORIES/MAINTENANCE ITEMS

SAFETY GOGGLES	71-85707
SEARS CRAFTSMAN® 40:1, 2-CYCLE ENGINE OIL	
--3.2 oz.	71-86552
--8 oz.	71-36555
SPARK PLUG	71-85853
AIR FILTER	530-036664

USING YOUR UNIT

▲ DANGER – THIS POWER TOOL CAN BE DANGEROUS!

This unit can cause serious injury including amputation or blindness to the operator and others. The warnings and safety instructions in this manual must be followed to provide reasonable safety and efficiency in using this unit. The operator is responsible for following the warnings and instructions in this manual and on the unit. **Read the entire Operator's Manual before using this unit!** Restrict the use of this unit to persons who read, understand, and follow the warnings and instructions in this manual and on the unit.

A. HEDGE TRIMMER SAFETY

1. OPERATOR SAFETY

- a. **Read the entire Operator's Manual before assembling and using this unit!** Restrict the use of this unit to persons who read, understand, and follow the warnings and instructions in this manual and on the unit.
- b. **Always wear eye protection** when operating, servicing, or performing maintenance on your unit. The cutting blades can cause debris to be thrown or ricochet into the eyes and face which can result in loss of vision or serious injury. See the "Accessories" section.
- c. **Always wear heavy, long pants, boots, and gloves.** Do not go barefoot or wear short pants, sandals, jewelry, loose clothing, or clothing with loosely hanging straps, ties, tassels, etc.; they can be caught in moving parts. Secure hair so it is above shoulder length. Being fully covered will help protect you from pieces of toxic plants such as poison ivy thrown by the blades, which could be more of a hazard than touching the plant itself.
- d. **Do not operate this unit when you are tired, ill, or under the influence of alcohol, drugs, or medication.**
- e. **Always keep both hands firmly gripped on the handles.**

2. UNIT

- a. **Inspect the entire unit before each use.** Always make sure all handles and guards are properly and securely fastened when using the unit. Replace damaged parts. Make sure all handles, guards, and fasteners are in place and securely fastened.
- b. **Make sure the cutting blades are properly installed and securely fastened.**

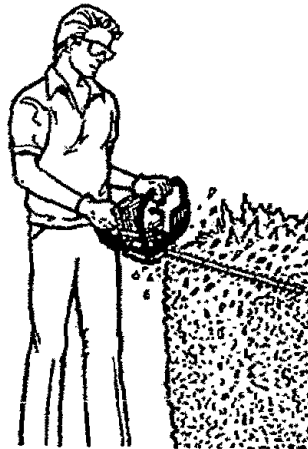

Figure 4

3. TRIMMING

- a. **Inspect the area to be cut before each use.** Remove objects (rocks, broken glass, nails, wire, string, etc.) which can be thrown or become entangled in the cutting blades.
- b. **Always keep the unit in front of your body.** Hold handle firmly with both hands. Figure 4.
- c. **Keep firm footing and balance.** Do not over-reach.
- d. **Do not raise engine above your shoulders.** The cutting blades can come dangerously close to your body.
- e. **Use only for jobs explained in this manual.**

B. OPERATING TIPS

As you become familiar with your unit, you will be able to determine your own operating pace. Conditions such as the type and size of material being cut will regulate the speed and time required for your job.

1. **Allow the cutting blades to reach full speed before entering the material to be cut.**
2. **Always work going away from people and solid objects** such as walls, large stones, trees, automobiles, etc.
3. **If the blade stalls, immediately stop the engine.** Make sure the ignition switch is off, the spark plug is disconnected, and the blade has stopped moving before clearing jammed debris from the cutting blade. Inspect the blade for damage and have it repaired or replaced as needed.
4. **To stop the engine, move the ignition switch to the "STOP" position.** Figure 2.

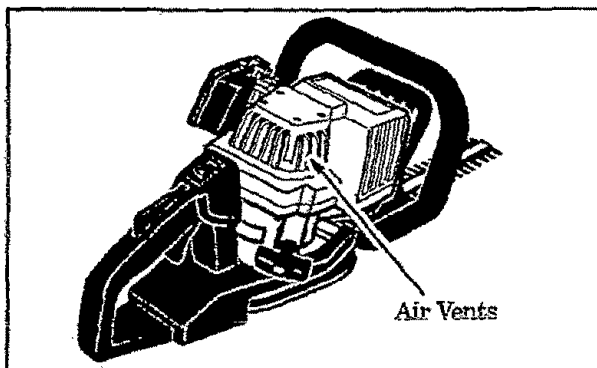

Figure 5

5. **Always keep the air vents clean.** Stop the unit, make sure the cutting blade has completely stopped moving, and disconnect the spark plug before cleaning.

C. TRIMMING METHODS

NOTE: Do not try to cut stems larger than 3/8" thick.

1. TOP CUTTING

a. For New or Young Growth:

When trimming new or young growth, use a wide, sweeping motion. Figure 6 A. A slight, downward tilt of the cutting blades in the direction of motion gives the best cutting results.

b. For Older, Thicker Growth:

Trim older, thicker growth by using a sawing motion. Figure 6 B.

c. For Precise, Level Cuts:

If a precisely level cut is desired, stretch a piece of string across the length of the hedge. Guide the cutting blades slowly across the top of the string. Figure 7.

2. SIDE CUTTING

When trimming the sides of the hedge, begin at the bottom and cut upward, tapering the hedge inward at the top. Figure 7 (inset). Cutting in this method will leave the body of the hedge narrower at the top. This shape will expose more of the hedge, resulting in more uniform growth.

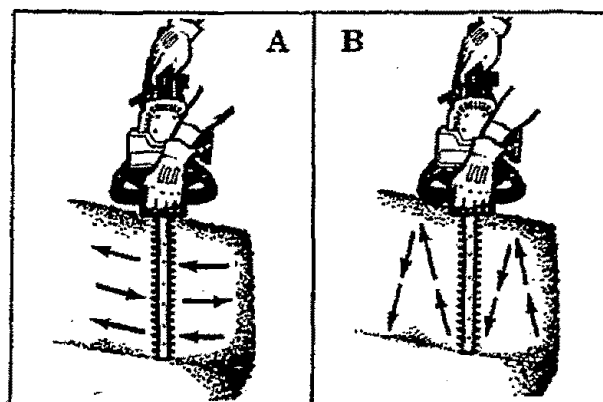

Figure 6

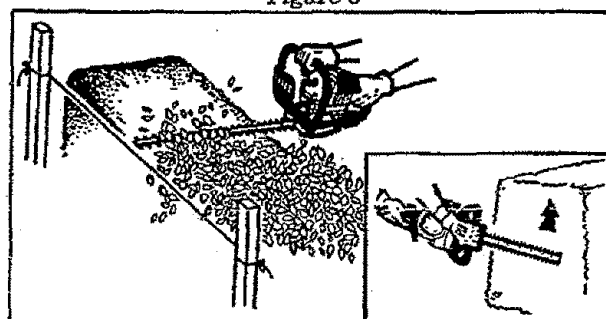

Figure 7

NOTES

CUSTOMER RESPONSIBILITY -- GENERAL MAINTENANCE

A. MAINTENANCE SAFETY

1. Maintain the unit according to recommended procedures.
2. Disconnect the spark plug before performing maintenance except for carburetor adjustments.
3. Make carburetor adjustments with the cutting blade clear of any object.
4. Keep others away when making carburetor adjustments.
5. Be sure blade stops turning when engine idles. See "Carburetor Adjustments."
6. Have your SEARS Service Center/Department replace a cutting blade that is cracked, chipped, broken, or damaged in any other way before using unit.
7. Use only genuine SEARS replacement parts as recommended.
8. Inspect the entire tool. Replace damaged parts. Check for fuel leaks and make sure all fasteners are in place and securely fastened.
9. Have all maintenance and service not explained in this manual performed by your SEARS Service Center/Department.

B. AIR FILTER

NOTE: A dirty air filter decreases life and performance of engine and increases fuel consumption.

1. Clean the air filter:

- Always after 5 tanks of fuel or 5 hours of operation, whichever is less.
- More frequently, in dusty conditions.
 - a. Loosen the two screws on the air filter cover enough to remove the cover from the engine. Figure 8.
 - b. Remove the air filter. Figure 8.
 - c. Wash filter in soap and water.
 - d. Squeeze filter dry and reinstall.

CAUTION: Do not clean the air filter in gasoline or other flammable solvent to avoid creating a fire hazard.

- e. Reinstall the air filter cover. Figure 8.

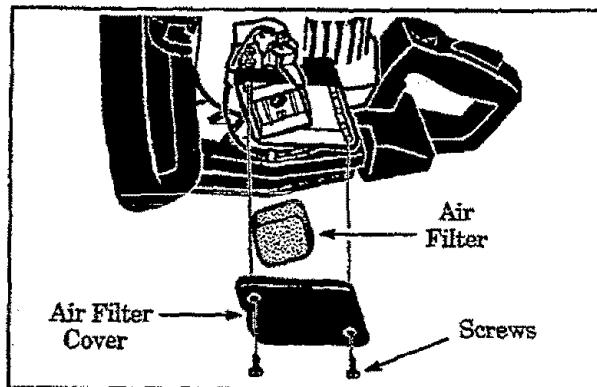

Figure 8

CAUTION: Make sure air filter is fitted into the corners of the cover to keep dust from entering engine and causing engine damage.

C. BLADE MAINTENANCE

▲ WARNING

The cutting blade will continue to move momentarily after trigger is released. Make sure the blade has stopped and the spark plug has been disconnected before performing maintenance.

▲ WARNING

Always replace a blade that is bent, warped, cracked, broken, or damaged in any other way. Never attempt to straighten and reuse a damaged blade. Use only the specified replacement blade.

CAUTION: Wear protective gloves when handling or performing maintenance on the cutting blade to help avoid injury.

- Check cutting blade for flatness periodically. Throw away a blade that is not flat.
- Do not use solvents or petroleum base cleaners of any kind or damage to the unit can occur.
- Do not allow water or other liquids to get into the trimmer housing. Never immerse any part of the unit into water or any other liquid.
- Do not store unit near fertilizers or chemicals which can corrode metal parts.

1. LUBRICATING THE CUTTING BLADE

Lubrication of the cutting blade after each use will lengthen blade life and make operation easier. To lubricate the cutting blade, do the following:

- a. Make sure the ignition switch is in the "STOP" position and the blade has stopped moving. Disconnect the spark plug.
- b. Remove any debris from the cutting blade.
- c. Clean all parts and check for damage. Have damaged parts repaired or replaced by qualified service personnel.
- d. Apply a light machine oil along the edge of the top strap as shown in Figure 9.

2. CLEANING

Use mild soap and a damp cloth to clean trimmer housing and decals. Do not use solvents or petroleum based cleaners of any kind or damage to the unit can occur. Do not allow water or other liquids to get into the trimmer housing, and never immerse any part of the unit into water or any other liquid.

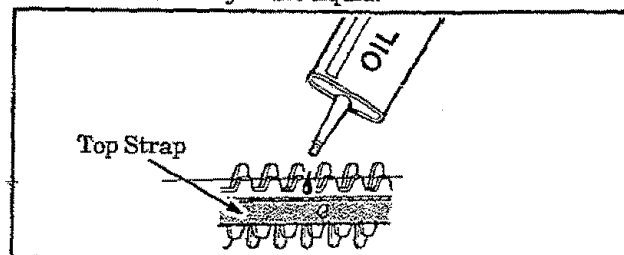

Figure 9

D. CARBURETOR ADJUSTMENTS

NOTE: This is a complicated task. Read all warnings and instructions thoroughly before starting adjustments. If you do not think that you completely understand all warnings and instructions, let your SEARS Service Center/Department perform these adjustments.

▲ WARNING

Make carburetor adjustments with the unit supported to prevent the blade from contacting any object.

▲ WARNING

Keep others away when making carburetor adjustments.

▲ WARNING

Serious injury to the operator and others can occur if the carburetor is not properly adjusted.

- Poor engine performance can be a result of other causes such as dirty air filter, carbon build-up on muffler outlets, clogged fuel filter, etc.. See the "Trouble Shooting Chart" before proceeding with carburetor adjustments.
- The carburetor has been carefully adjusted at the factory. However, the operator must be sure that adjustments are made when any of the conditions occur as mentioned in the "Trouble Shooting Suggestions" section.
- Very small adjustments can affect engine performance. It is important to turn the screw a very small amount per adjustment and test performance before making further adjustments. Each adjustment should be no more than the width of the slot in the adjusting screw.
- This is a complicated task and it is important to follow instructions in sequence as indicated.

1. TROUBLE SHOOTING SUGGESTIONS

- Engine will not continue to run at idle position. See "Idle Speed Adjustment" and "Low Speed Adjustment."
- Blade continues to move when the engine idles. See "Idle Speed Adjustment" and "Deceleration Check."
- Engine dies or hesitates when it should accelerate. See "Acceleration Check."
- Loss of cutting power which cannot be corrected by cleaning the air filter. See "High Speed Adjustment."
- Engine does not return to idle from full throttle within 2 seconds. See "Deceleration Check."
- Engine will not run. See "Trouble Shooting Chart." Then, if the carburetor requires adjustment, begin with "Basic Carburetor Settings."

▲ WARNING

The blade will be moving during most of this procedure. Wear your protective equipment and observe all safety instructions.

2. BASIC CARBURETOR SETTINGS

NOTE: In most cases, your engine can be made to run properly with minor carburetor adjustments. Refer to "Trouble Shooting Suggestions" for the condition you are experiencing and follow the instructions. The basic carburetor settings are provided in the following instructions.

- a. Turn low speed screw and high speed screw (Figure 10) clockwise until they stop. Do not turn screws until they are tight as damage to needle seats can occur.
- b. Turn the low speed screw between three-quarters and one full turn counterclockwise.
- c. Turn the high speed screw one to one and one-quarter full turns counterclockwise.

3. ADJUSTING PROCEDURE

a. PREPARATION

1. Use a fresh fuel mix. See "Fueling Your Engine."
2. Start the engine. Trim hedges for 3 minutes to warm engine. The engine must be at operating temperature before carburetor adjustments can be performed correctly.

b. IDLE SPEED ADJUSTMENT

1. Allow engine to idle.
2. Adjust idle speed screw (Figure 10) until the engine continues to run without stalling and without blade moving.
 - Turn idle speed screw clockwise to increase engine speed if the engine stalls or dies.
 - Turn idle speed screw counterclockwise to slow engine down and/or to keep blade from turning.
3. Follow instructions in "Acceleration Check" and "Deceleration Check."
4. No further adjustments are necessary if the blade does not move at idle speed and if performance is satisfactory.

▲ WARNING

Recheck idle speed after each adjustment. The blade must not move at idle speed to avoid serious injury to the operator and others.

c. ACCELERATION CHECK

1. Allow the engine to idle.
 2. Squeeze the throttle trigger fully.
 - a. If performance is satisfactory, proceed to "d. Deceleration Check."
 - b. If the engine does not accelerate smoothly, turn the low speed screw (Figure 10) counterclockwise a small amount (no more than the width of the slot in the adjusting screw).
 3. Repeat step "2.b." until smooth acceleration is obtained.
- NOTE:** It may be necessary to repeat "Idle Speed Adjustment" through "Acceleration Check," to obtain correct adjustments.
4. Follow instructions in "Deceleration Check."

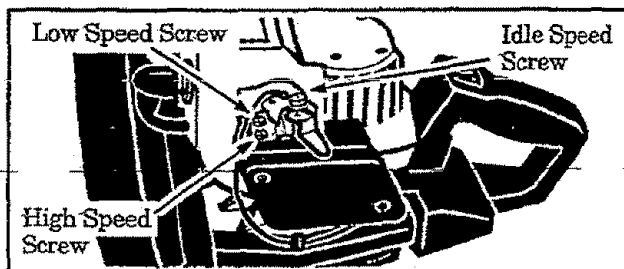

Figure 10

d. DECELERATION CHECK

1. Allow the engine to idle, then squeeze the throttle trigger fully.
2. Allow the engine to run at full speed for about 1 second.
3. Release the throttle trigger to the idle position and listen to the deceleration of the engine. The engine must return to idle smoothly and within 1 to 2 seconds. If the engine slowly or erratically returns to idle or idles erratically, repeat "Idle Speed Adjustment" or continue through Low Speed and High Speed Adjustments to obtain proper deceleration.
4. Recheck idle speed.

e. LOW SPEED MIXTURE ADJUSTMENT

1. Allow the engine to idle.
2. Turn the low speed screw (Figure 10) slowly clockwise until the speed starts to drop. Note this position.
3. Turn the low speed screw counterclockwise until the speed increases and then starts to drop again. Note this position.
4. Set the low speed screw at the midpoint between the two positions.
5. Follow instructions in "Acceleration Check" and "Deceleration Check."

CAUTION: If the engine does not operate according to these instructions after repeating the adjusting steps, do not use the tool. Take it to your SEARS Service Center/Department.

f. HIGH SPEED MIXTURE ADJUSTMENT

CAUTION: Adjustments as small as 1/16 of a turn can affect engine performance. It is important to turn the screw only 1/16 of a turn per adjustment and test the performance of the unit before making further adjustments.

CAUTION: A too lean high speed setting (clockwise adjustment) will cause engine damage to any 2-cycle engine from overheating and lack of lubrication. Never set the high speed mixture screw so far clockwise that you have high speed but lack power while cutting. Never set the high speed mixture screw less than 3/4 turns open. Adjust the high speed mixture screw 1/16 of a turn at a time as follows:

NOTE: 1/16 of a turn is approximately the width of the screwdriver slot in the top of the screw.

1. Turn the high speed mixture screw clockwise if the unit loses power.
2. Turn the high speed mixture screw counterclockwise if the unit has speed out of the cut but lacks power while cutting.
3. Repeat test cut. Continue 1/16 of a turn adjustments until the unit runs smoothly in the cut.

CAUTION: Set the high speed mixture screw as far counterclockwise as possible to provide a smooth running engine and proper acceleration.

CAUTION: If the engine does not operate according to these instructions after repeating the adjusting steps, do not use the tool. Take it to your SEARS Service Center/Department.

NOTES

Immediately prepare your unit for storage at the end of the season or if it will not be used for 30 days or more.



WARNING:
ALLOW THE ENGINE TO COOL, AND SECURE THE UNIT BEFORE STORING OR TRANSPORTING IT IN A VEHICLE.

STORE UNIT AND FUEL IN AN AREA WHERE FUEL VAPORS CANNOT REACH SPARKS OR OPEN FLAMES FROM WATER HEATERS, ELECTRIC MOTORS OR SWITCHES, FURNACES, ETC.

STORE UNIT WITH ALL GUARDS IN PLACE. POSITION SO THAT ANY SHARP OBJECT SUCH AS BLADES CANNOT ACCIDENTLY CAUSE INJURY TO PASSER BY.

STORE THE UNIT OUT OF THE REACH OF CHILDREN.

GAS HEDGE TRIMMER STORAGE INSTRUCTIONS

If your trimmer is to be stored for a period of time, clean it thoroughly prior to storage. Remove any dirt, sawdust, leaves, oil, grease, etc. Store in a clean dry area.

- Clean the entire unit.
- Clean air filter. Refer to "Customer Responsibilities".
- Lightly oil external metal surfaces to prevent rust from forming.



CAUTION: Wear protective gloves when handling blade. The blade is sharp and can cut you even when it is not moving.

- If your unit is equipped with a blade, remove it from the unit. Refer to "Assembly". Apply a coating of oil to the entire surface of the blade and wrap it in heavy paper, cloth, or plastic. Also apply a light coat of oil to gear housing threads, then tighten blade nut for storage.
- Reassemble all loose parts, being sure that all handles and guards are in place and are securely fastened. Replace any damaged parts.

ENGINE

Never use engine or carburetor cleaner products in the fuel tank or permanent damage may occur to fuel system components.

Follow these instructions:

1. Drain the fuel from the unit into an approved fuel container.
2. Drain the fuel lines and carburetor by starting the engine and letting it run until it stops.
3. Allow the engine to cool before storage.

IMPORTANT: It is important to prevent gum deposits from forming in essential fuel system parts such as the carburetor, fuel filter, fuel line or tank during storage. Also, experience indicates that alcohol blended fuels, those that use ethanol or methanol (called gasohol or oxygenated fuel), can attract moisture and form acidic gas which will damage your engine. To avoid engine problems, the fuel system should be emptied before storage of 30 days or longer.

NOTE: Fuel stabilizer is an acceptable alternative in minimizing the formation of fuel gum deposits during storage. Add stabilizer to the gasoline in the fuel tank or fuel storage container. Always follow the mix instructions found on stabilizer container. Run engine at least 5 minutes after adding stabilizer to allow the stabilizer to reach the carburetor.

NOTE: Craftsman 40:1 2-cycle engine oil is specially blended with fuel stabilizers. If you do not use this SEARS oil, you can add a fuel stabilizer (such as Craftsman #33500) to your fuel tank.

- Remove spark plug and pour 1 teaspoon of 40:1 oil mix through the spark plug opening. Slowly pull the starter rope 8 to 10 times to distribute oil to inner engine surfaces.
- Replace spark plug with a new one of the recommended type and heat range. Refer to "Product Specifications".
- Clean air filter. Refer to "Customer Responsibilities".
- Reinstall all covers and hardware removed for access; tighten all screws and fasteners.
- Check entire unit for loose screws, nuts, and bolts. Replace any damaged, broken, or worn parts.
- Use fresh fuel having the proper gasoline to oil ratio at the beginning of the next season.

OTHER

- Do not store gasoline from one season to another.
- Replace your gasoline can if your can starts to rust. Rust and/or dirt in your fuel system will cause problems.
- Store your unit in a well ventilated area and covered, if possible, to prevent dust and dirt accumulation. Do not cover with plastic. Plastic cannot breathe and will induce condensation and eventual rust or corrosion.

IMPORTANT: Never cover unit while engine and exhaust areas are still warm.

E. TROUBLE SHOOTING CHART

SYMPTOM	CAUSE	REMEDY
Engine will not start or will run only for a few seconds after starting.	<ol style="list-style-type: none"> 1. Fuel tank empty. 2. Engine flooded. 3. Spark plug not firing. 4. Fuel not reaching carburetor. 5. Carburetor requires adjustment. 6. Air filter dirty. 7. Fuel filter dirty. 8. None of the above. 	<ol style="list-style-type: none"> 1. Fill tank with correct fuel mixture 2. See "Starting Instructions." 3. Install new plug/check ignition system. 4. Clean fuel filter; inspect fuel line. 5. See "Carburetor Adjustments." 6. Clean or replace air filter. 7. Contact your SEARS Service Center/Dept. 8. Contact your SEARS Service Center/Dept.
Engine will not idle properly.	<ol style="list-style-type: none"> 1. Idle speed set too fast or too slow. 2. Requires adjustment. 3. None of the above. 	<ol style="list-style-type: none"> 1. See "Carburetor Adjustments." 2. See "Carburetor Adjustments." 3. Contact your SEARS Service Center/Dept.
Engine will not accelerate, lacks power, or dies under a load.	<ol style="list-style-type: none"> 1. Air filter dirty. 2. Spark plug fouled. 3. Carburetor requires adjustment. 4. Muffler outlets plugged. 5. None of the above. 	<ol style="list-style-type: none"> 1. Clean or replace air filter. 2. Clean and re-gap or replace spark plug. 3. See "Carburetor Adjustments." 4. Contact your SEARS Service Center/Dept. 5. Contact your SEARS Service Center/Dept.
Engine smokes excessively.	<ol style="list-style-type: none"> 1. Air filter dirty. 2. Fuel incorrect. 3. Requires adjustment. 	<ol style="list-style-type: none"> 1. Clean or replace air filter. 2. Refuel with correct fuel mixture. 3. See "Carburetor Adjustments."
Engine runs hot.	<ol style="list-style-type: none"> 1. Fuel incorrect. 2. Set too low (Lean). 3. Spark plug incorrect. 4. None of the above. 	<ol style="list-style-type: none"> 1. See "Fueling Your Unit." 2. See "Carburetor Adjustments." 3. Replace with correct plug. 4. Contact your SEARS Service Center/Dept.
Cutting attachment moves at idle speed.	<ol style="list-style-type: none"> 1. Carburetor requires adjustment. 2. Throttle cable binding. 3. Clutch requires repair. 	<ol style="list-style-type: none"> 1. See "Carburetor Adjustments." 2. Contact your SEARS Service Center/Dept. 3. Contact your SEARS Service Center/Dept.
Cutting Blade stops under a load or does not turn when the engine is accelerated.	<ol style="list-style-type: none"> 1. Forcing blade into material being cut. 2. Blade clogged with debris. 3. None of the above. 	<ol style="list-style-type: none"> 1. Cut at a slower pace. 2. Clean debris from blade. 3. Contact your SEARS Service Center/Dept.

NOTES

SEARS GAS HEDGE TRIMMER REPAIR PARTS LIST – MODEL 358.795620

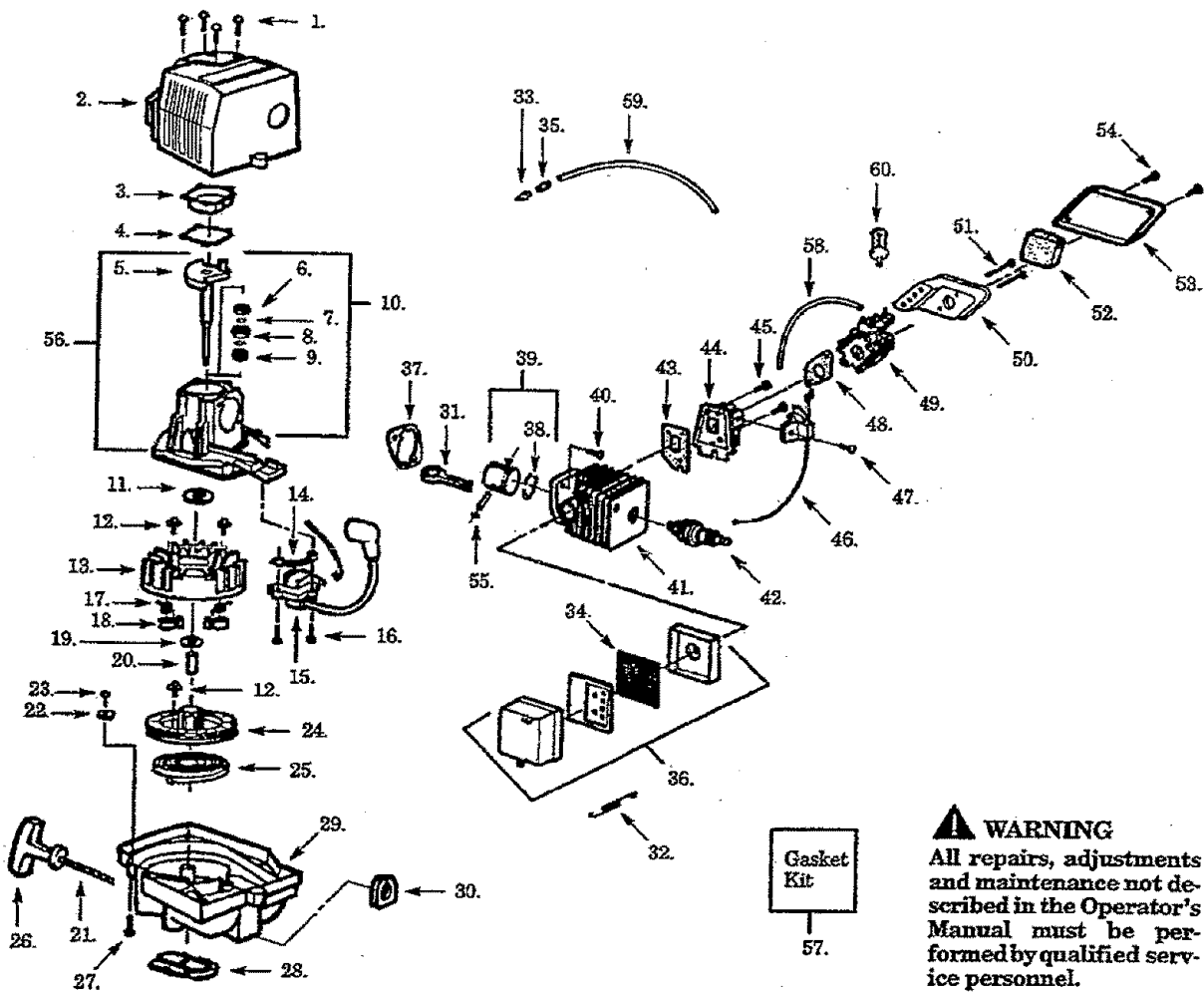

WARNING
 All repairs, adjustments and maintenance not described in the Operator's Manual must be performed by qualified service personnel.

Ref.	Part No.	Description	Ref.	Part No.	Description	Ref.	Part No.	Description
1.	530-015935	Screw	25.	530-029395	Starter Spring	49.	530-035306	Carburetor
2.	530-037631	Shroud	26.	530-027569	Starter Handle	50.	530-036192	Air Box
3.	530-029929	Crankcase Cover	27.	530-015310	Screw	51.	530-015849	Screw
4.	530-019181	Gasket	28.	530-014396	Clutch Ass'y. Kit	52.	530-029934	Air Filter Foam
5.	530-014307	Crankshaft Ass'y.	29.	530-014947	Fan Housing	53.	530-036193	Air Filter Cover
6.	530-032125	Inner Bearing	30.	530-019182	Grommet	54.	530-015635	Screw
7.	530-015945	Retaining Ring	31.	530-014397	Connecting Rod Assy.	55.	530-015162	Piston Pin Retainer
8.	530-019179	Crankcase Seal	32.	530-029930	Muffler Spring	56.	530-014973	C'case & C'shaft Assy. (Incl. 5 & 10)
9.	530-032124	Outer Bearing	33.	530-026119	Check Valve	57.	530-069374	Gasket Kit (Incl. 4, 37, 43 & 48)
10.	530-014861	Crankcase Ass'y. (Incl. 6-9)	34.	530-036180	Muffler Screen			
11.	530-015941	Retaining Ring	35.	530-024475	Vent Fitting			
12.	530-015882	Screw	36.	530-069352	Muffler Kit	58.	530-069247	Fuel Line
13.	530-039149	Flywheel Ass'y.	37.	530-019186	Cylinder Gasket	59.	530-069216	Vent Line
14.	530-036145	Spacer	38.	530-036404	Piston Ring	60.	530-014362	Fuel Pick-up Ass'y.
15.	530-039163	Ignition Module	39.	530-069387	Piston Kit (Incl. 38 & 55)			
16.	530-015954	Screw	40.	530-015953	Screw			
17.	530-029940	Spring	41.	530-012309	Cylinder			
18.	530-029939	Starter Dog	42.	530-030073	Spark Plug			
19.	530-015828	Washer	43.	530-019185	Gasket			
20.	530-015930	Flywheel Spacer	44.	530-037632	Carb. Adaptor		530-081187	Operator Manual
21.	530-069232	Rope Kit	45.	530-016014	Screw		530-061860	Carton
22.	530-015963	Retainer	46.	530-014384	Throttle Cable Ass'y.		530-037634	Starting Instruction
23.	530-015496	Screw	47.	530-015775	Screw			
24.	530-069353	Starter Pulley	48.	530-019183	Gasket			

SEARS GAS HEDGE TRIMMER REPAIR PARTS LIST - MODEL 358.795620

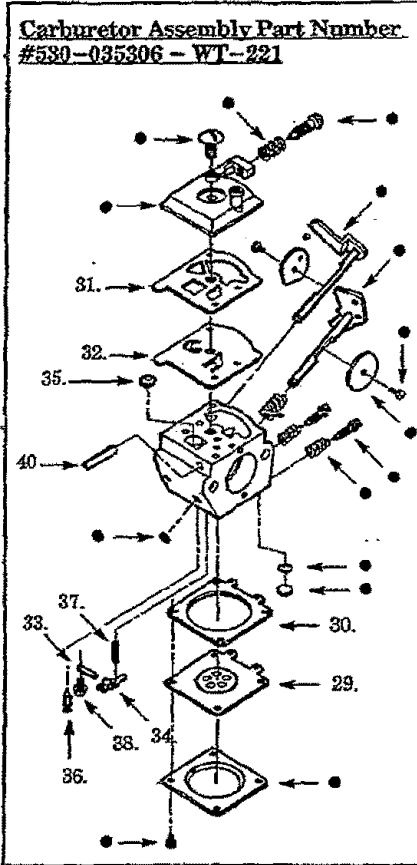
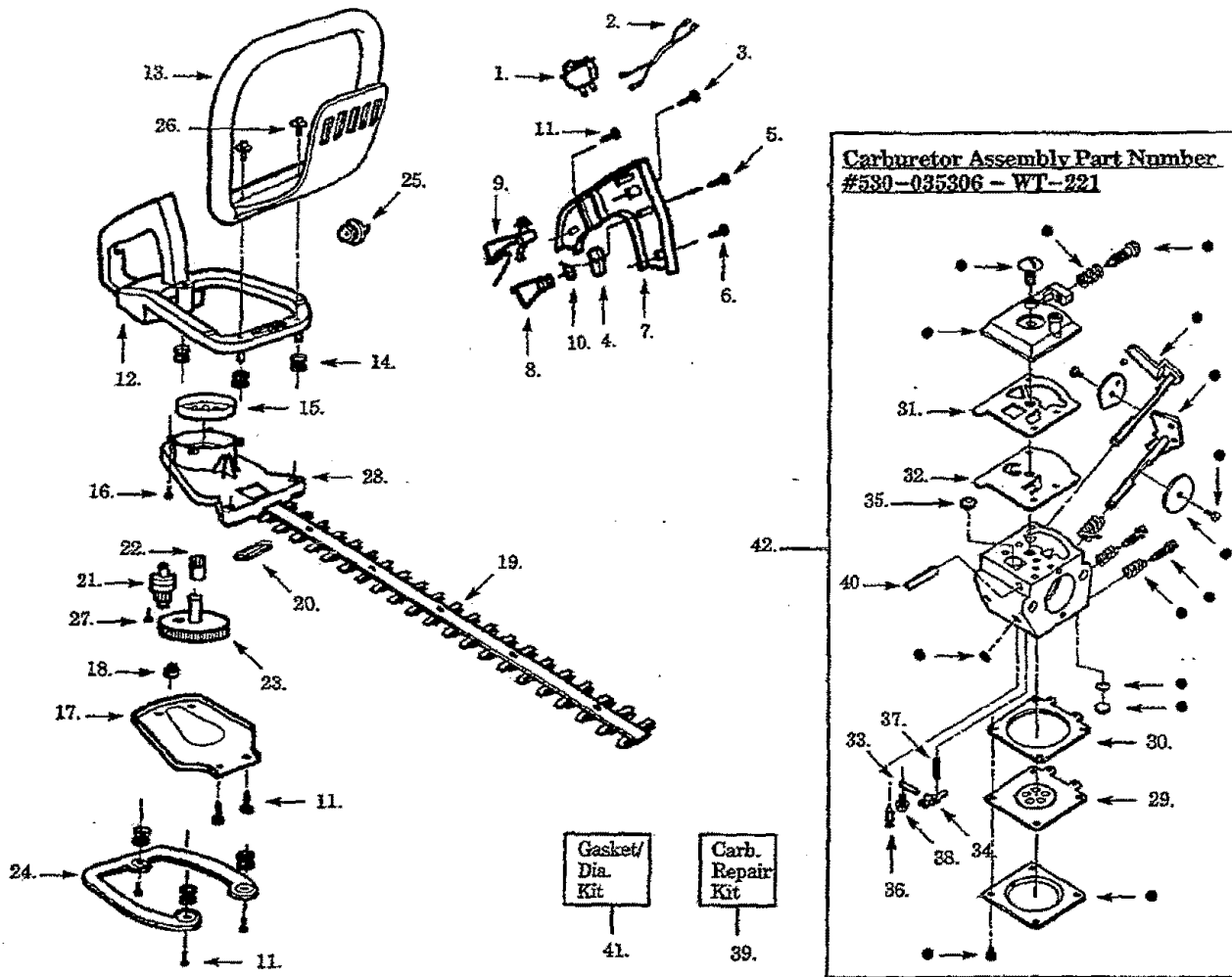

Ref.	Part No.	Description	Ref.	Part No.	Description	Ref.	Part No.	Description
1.	530-029954	Ignition Switch	22.	530-016013	Drive Gear Bearings	40.	530-035319	Welch Plug
2.	530-036443	Lead Wire Ass'y.	23.	530-069355	Drive Gear Ass'y.	41.	530-035313	Gasket/Diaphragm Kit (Incl. 29-32)
3.	530-015775	Screw	24.	530-036046	Isolator Plate	42.	530-035306	Carburetor Ass'y.
4.	530-029958	Trigger Lever	25.	530-014678	Fuel Cap Ass'y.			
5.	530-015940	Screw	26.	530-015955	Screw			
6.	530-015770	Screw	27.	530-015805	Screw			
7.	530-029960	Handle Cover	28.	530-014999	Gear Box Ass'y. (Incl. 21, 22 & 27)			
8.	530-029956	Throttle Trigger	29.	530-035014	Metering Diaphragm			
9.	530-036122	Throttle Lockout	30.	530-035332	Metering Diaphragm Gasket			
10.	530-036123	Trigger Spring	31.	530-035164	Pump Gasket			
11.	530-015934	Screw	32.	530-035166	Pump Diaphragm			
12.	530-029963	Rear Handle & Tank Ass'y.	33.	530-035028	Metering Pin			
13.	530-094992	Front Handle	34.	530-035031	Metering Lever			
14.	530-029946	Isolator Spring	35.	530-035178	Fuel Inlet Screen			
15.	530-048113	Clutch Drum	36.	530-035223	Inlet Needle Valve			
16.	530-015886	Screw	37.	530-035139	Metering Lever Spring			
17.	530-029916	Gear Box Plate	38.	530-035236	Metering Lever Pin Screw			
18.	530-032121	Bushing Blade	39.	530-035312	Carburetor Repair Kit (Incl. 33-38, & 40)			
19.	530-095074	Blade Ass'y. (22")						
20.	530-029948	Blade Seal						
21.	530-036228	Pinion Ass'y.						

NOTES

NOTES

NOTES

SEARS

Operator's Manual

Model No.
358.795620

How to Order Repair Parts

**SEARS SERVICE
IS AT YOUR SERVICE**

The Model Number will be found below the top handle with the Serial Number. Always mention the Model Number when requesting service or repair parts for your unit.

All parts listed herein may be ordered from any Sears Service Center and most Sears Stores.

WHEN ORDERING REPAIR PARTS ALWAYS GIVE THE FOLLOWING INFORMATION AS SHOWN IN THIS LIST:

- | | |
|-----------------------------------|--|
| 1. The PART NUMBER | 3. The PART DESCRIPTION |
| 2. The MODEL NUMBER
358.795620 | 4. The NAME OF ITEM --
Gasoline Hedge Trimmer |

If the parts you need are not stocked locally, your order will be transmitted to a Sears Repair Parts Distribution Center for handling.



When you buy merchandise from Sears you get an extra value that nobody else can offer --- Sears Service.

Across town or across the country, Sears Service is always near, providing trustworthy, competent service technicians using only Sears specified factory parts.

Your Sears Merchandise takes on added value when you discover that Sears has Service Units throughout the country. Each is staffed by Sears-Trained, professional technicians using Sears approved methods.

Sears, Roebuck and Co., Hoffman Estates, IL 60179 USA

PRINTED IN U.S.A.