

SEARS Kenmore

CONTENTS

SAFETY

1-5

USE AND CARE

Your Range and Its Features	6
Cooktop Cooking	7, 8
Range Control	9
Clock & Timer	10
Oven Cooking	11, 12, 13
Broiling	14
Self-Clean Cycle	15, 16
Cleaning Tips	17, 18
Removable Parts	19, 20
Removal of Packaging Tape	20

BEFORE CALLING FOR SERVICE

What to Do Before Calling for Service	21, 22
Temperature Adjustments	23

WARRANTY

MODELS 46745, 46749
46756, 46755
46759

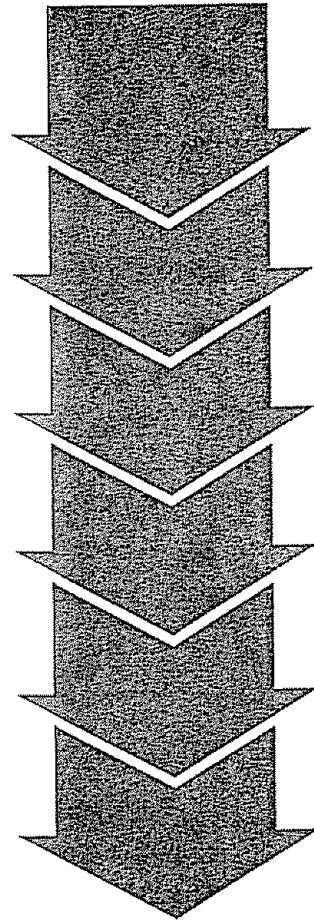

USE • CARE • SAFETY MANUAL



Recycled Paper

229C4020P019-3 SR10222

STABILITY DEVICE

	 <h2>WARNING</h2>
	<ul style="list-style-type: none"> • ALL RANGES CAN TIP • INJURY TO PERSONS COULD RESULT • INSTALL ANTI-TIP DEVICES PACKED WITH RANGE • SEE INSTALLATION INSTRUCTIONS

REMOVE ALL PARTS FROM THE PLASTIC BAG ATTACHED TO THE BACK OF THE RANGE AND SAVE PACKAGING TAPE.

- 1) Before placing range in the counter, notice the location of the stability bracket which is already attached to the back of the range. This location should work for most installations. However, it may be more convenient to hook the stability chain to the unit when the stability bracket is attached to the upper set of holes in the back of the range (See Fig. 1). The upper set of holes are intended for use with a backsplash kit. If a backsplash kit is being used, the stability bracket can be relocated and put on at the same time as the backsplash kit. If the backsplash is not being used, make sure that there are no structural supports for the countertop which will interfere with the stability bracket when located in the upper set of holes.
- 2) Fasten one end of the stability chain to the floor or the wall with the long screw and washer supplied (See Fig. 2). Make certain the screw is going into the wall plate at the base of the wall or one of the studs in the base of the wall (See Fig. 3). Whether you attach the chain to the wall or floor, be certain that the screw is in at least 3/4" thickness of wood other than baseboard and that there are no electrical wires or plumbing in the area in which the screw could penetrate. Attach the stability chain in a location which will allow the chain to be in line with the bracket side to side as much as possible when attached to the unit. Test to see if the chain is securely fastened by tugging on the chain.
- 3) Temporarily attach the loose end of the chain to the rear of the countertop with the tape from the packaging (See Fig. 4).
- 4) Place the range in the counter cutout leaving just enough room between the back of the range and the wall to reach the stability bracket.
- 5) Hook the loose end of the chain onto the bracket by slipping the nearest link of the chain into the slot in the bracket (See Fig. 1), making sure the chain is

pulled as tight as possible and that there is no excess slack in the chain after chain is attached to the bracket.

- * Excess slack in the chain could allow the range to tip over.
- 6) Slide the range all the way back into the counter. Once the range is pushed back in place, there will be a small amount of slack in the chain. This is normal.

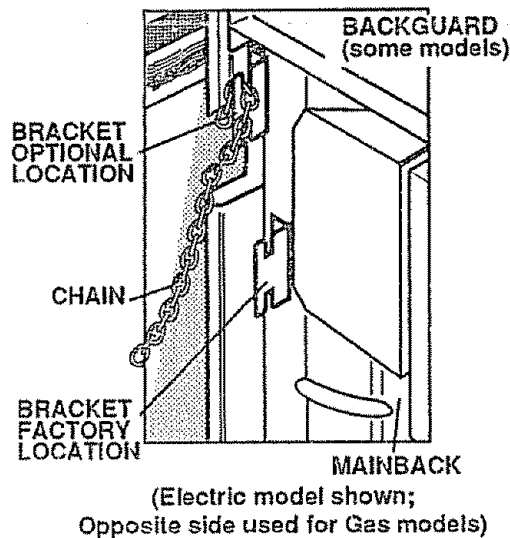

Fig. 1

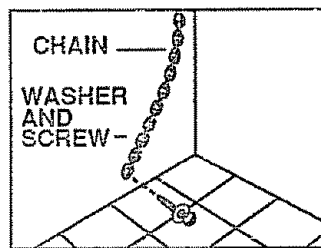

Fig. 2

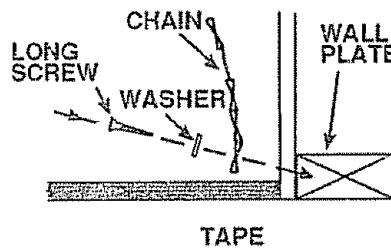

Fig. 3

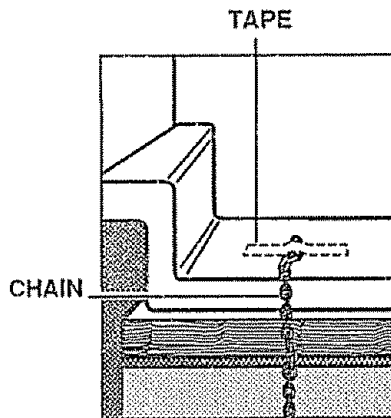

Fig. 4

IMPORTANT IMPORTANT IMPORTANT IMPORTANT IMPORTANT IMPORTANT IMPORTANT IMPORTANT IMPORTANT

IMPORTANT INSTRUCTIONS FOR YOUR SAFETY

SAVE THESE INSTRUCTIONS

Read all instructions before using this appliance. When using electrical appliances, basic safety precautions should be followed, including the following:

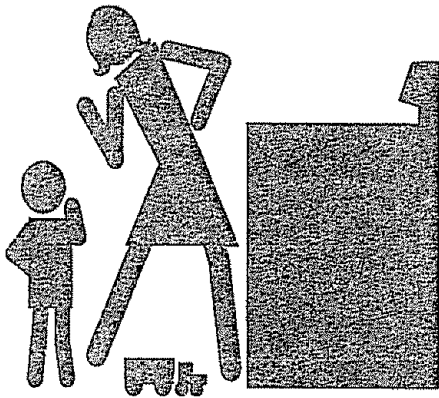

Teach children not to play with range knobs or any other part of the range.
Never leave children alone or unattended where a range is in use.

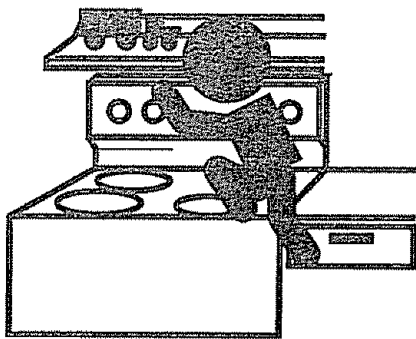
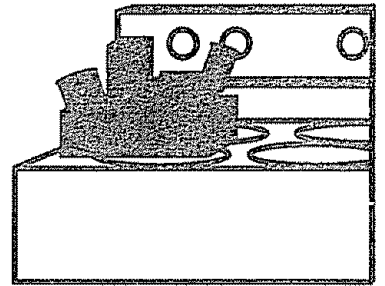

CAUTION:

Items of interest to children should not be stored in cabinets above the range or on the backsplash of the range. Children climbing on the range to reach items could be seriously injured.

Never let anyone climb, sit or stand on the open door or any other part of the range. Their weight may make the range tip over.

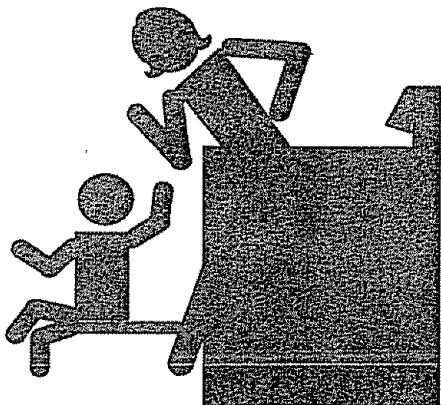
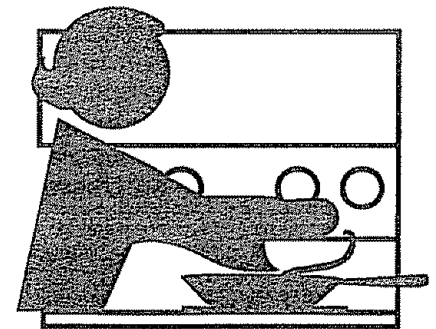

Never leave the oven door open when you are not watching the range.



IMPORTANT IMPORTANT IMPORTANT IMPORTANT IMPORTANT IMPORTANT IMPORTANT IMPORTANT IMPORTANT

To insure safety for yourself and your home, please read your Owner's Manual carefully. Keep it handy for quick easy reference. Pay close attention to the safety sections of your manual. You can recognize the safety sections by looking for the  symbol or the word "Safety".

Always keep the range area clear and free from things that will burn.

CAUTION:

Never store things in an oven or near cooktop elements/burners. These things may catch fire and plastic items could melt.

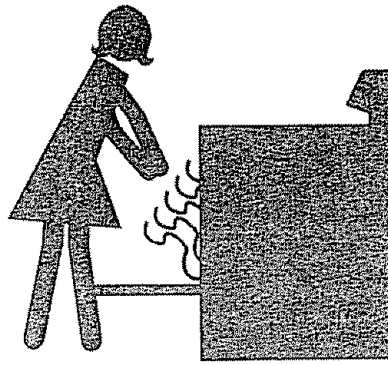

Never use your range for warming or heating a room. You could be burned or seriously injured. Such misuse could also cause damage to the range.

Never wear loose clothing when using your range. Such clothing could catch fire.

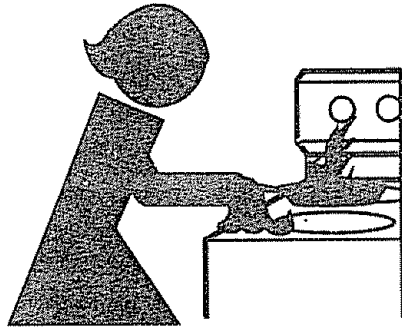

Never use a towel or other bulky cloth as a potholder. Such cloths could catch fire on a hot element/burner.

Never let pot handles stick out over the front of the range. Turn handles in so that they cannot be bumped into. Keep the handles away from other hot surface elements/burners.

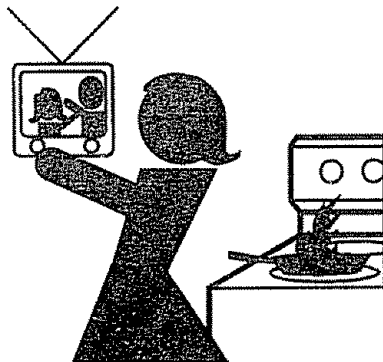

Never leave cooktop elements/burners unwatched at high heat settings. Boilovers cause smoking and greasy spillovers could catch fire.

IMPORTANT SAFETY INSTRUCTIONS

BASIC SAFETY PRECAUTIONS

Keep this book for later use.

Be sure your range is installed and grounded properly by a qualified technician.

Always use dry potholders when removing pans from the oven or cooktop. Moist or damp potholders can cause steam burns.

Always follow cleaning instructions in this book.

Always keep the range and oven clean. Food and grease are easy to ignite. Clean the range, oven and vents regularly.

Clean Only Parts Listed in Manual.

CAUTION: Do not store items of interest to children in cabinets above a range or on the backguard of a range. Children climbing on a range to reach items could be seriously injured.

Always keep combustible wall coverings, curtains, or drapes a safe distance away from your range and oven.

Always keep dish towels, dish cloths, potholders and other linens a safe distance away from your range. Never store such items on your range.

Always keep the appliance area clear and free from things that will burn (gasoline and other flammable vapors and liquids).

Never try to repair or replace any part of the range unless instructions are given in this book. All other work should be done by a skilled technician.

Never heat unopened food containers. Pressure buildup may make container burst and cause injury.

Never leave jars or cans of fat or drippings on or near the range. Never let grease build up on your range. You can keep grease fires from starting if you clean up grease and spills after each range use.

Never try to move a pan of hot fat, especially a deep fat fryer. Wait until the fat has cooled.

Never touch surface units, heating elements, or interior surfaces of the oven. They may be hot even though they appear dark in color.

Always keep wooden or plastic utensils and canned food a safe distance away from your range.

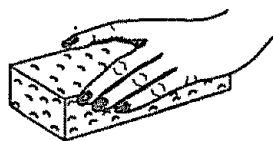

Some cleaners produce noxious fumes and wet cloths or sponges could cause steam burns if used on a hot surface.

COOKTOP SAFETY

Always use care when touching the cooktop. Heating elements could be hot enough to burn you even if they

are dark in color. The glass surface of the cooktop will retain heat after the controls are turned off.

Only some kinds of glass or ceramic pans can be used for cooktop cooking. Be sure that the pan you use will not break when heated on the cooktop elements.

Never block free airflow through the oven vent.

Do not cook on broken cooktop. If cooktop should break, cleaning solutions and spillovers may penetrate the broken cooktop and create a risk of electrical shock. Contact a qualified technician immediately.

For major spills — Turn unit to LO; use dry paper towels to wipe up major spills, and then use a razor scraper (held in a potholder) to scrape major spills from a hot cooking zone. **DO NOT** attempt further cleaning until cooktop surface has cooled.



Choose pots and pans with flat bottoms, large enough to cover the entire cooktop element. This will cut down the risk of setting potholders or clothing on fire with an uncovered element and waste less energy.

OVEN SAFETY

Place oven racks in desired position while oven is cool. If rack must be moved while oven is hot, do not let potholder contact hot heating element in oven.

After broiling, always take the broiler pan out of the range and clean it. Leftover grease in the broiler pan can catch on fire next time you use the pan.

Always use care when opening oven door. Let hot air and steam out before moving food.

Never use aluminum foil to line drip bowls or oven bottoms. Improper use of foil could start a fire.

SELF-CLEAN SAFETY

If the self-cleaning mode malfunctions, turn off and disconnect the power supply. Have serviced by a qualified technician.

Always remove broiler pan and other utensils from the oven before a self-clean cycle.

Never rub, move, or damage the door gasket on self-cleaning ranges. The gasket is essential for a good seal.

Never try to clean utensils, cookware or removable parts of your range during a self-clean cycle.

Do Not Use Oven Cleaners — No commercial oven cleaner or oven liner protective coating of any kind should be used in or around any part of the oven.

SAFETY INSTRUCTIONS (continued)

READ AND UNDERSTAND THIS INFORMATION NOW!

Should you ever need it, you will not have time for reading.

Be sure everyone in your home knows what to do in case of fire.

Never use water on a grease fire - it will only spread the flames.

IMPORTANT SAFETY NOTICE

The California Safe Drinking Water and Toxic Enforcement Act requires the governor of California to publish a list of substances known to the state to cause birth defects or other reproductive harm and requires businesses to warn customers of potential exposure to such substances. The fiberglass insulation in self-cleaning ovens gives off a very small amount of carbon monoxide during the cleaning cycle. Exposure can be minimized by venting with an open window or using a ventilation fan or hood.

COOKTOP GREASE FIRE

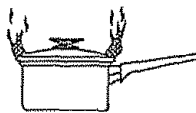

Never pick up a flaming pan!! Instead:

1. Turn off the element.
2. Smother the fire with a tightly fitting pan lid, baking soda or an extinguisher.

OVEN FIRE —

DO NOT TRY TO MOVE THE PAN!



1. Close oven door and turn controls off.
2. If fire continues, throw baking soda on the fire, or use a dry chemical, foam, or halon type extinguisher.

IMPORTANT INSTRUCTIONS TO AVOID DAMAGE TO YOUR RADIANT COOKTOP:

- Never slide cookware across your cooktop.
- **DO NOT** use a dish towel or sponge to wipe the cooktop. They may leave a detergent film on the cooktop which may cause discoloration when heated. If this occurs, remove the discoloration with a recommended cooktop cleaner.
- Sugary spills (such as jellies, fudge, candy syrups) or melted plastics can cause pitting to the surface of your cooktop (not covered by the warranty) unless the spill is removed while hot. Special care should be taken when removing hot substances. Turn off all the cooking zones affected by the spill. Remove hot pans. Wearing an oven mitt, hold the razor scraper at a 30° angle to the cooktop and scrape hot spill to a cooler area outside the cooking zone. With spill in a cool area, use a dry paper towel to remove any excess. Any spill remaining should be left until the surface of the cooktop has cooled. Follow the instructions given in your manual for additional cleaning.
- **DO NOT** use scouring powders or plastic, nylon or metal cleaning pads. They may scratch the cooktop.
- **DO NOT** use chlorine bleach, ammonia, hydrofluoric acid, chemical oven cleaners, or any other kind of chemical cleaner. They may discolor the cooktop.
- To avoid possible damage to cooking surfaces, do not apply cooktop cleaning creme to hot surfaces.
- After cleaning, use a damp cloth or paper towel to remove all cooktop cleaning creme residue.
- Consumer should read and follow all instructions and warnings on cooktop cleaning creme labels.

YOUR RANGE

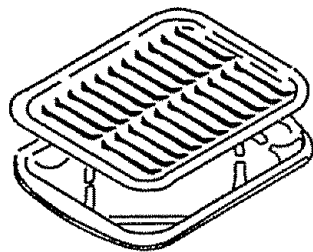
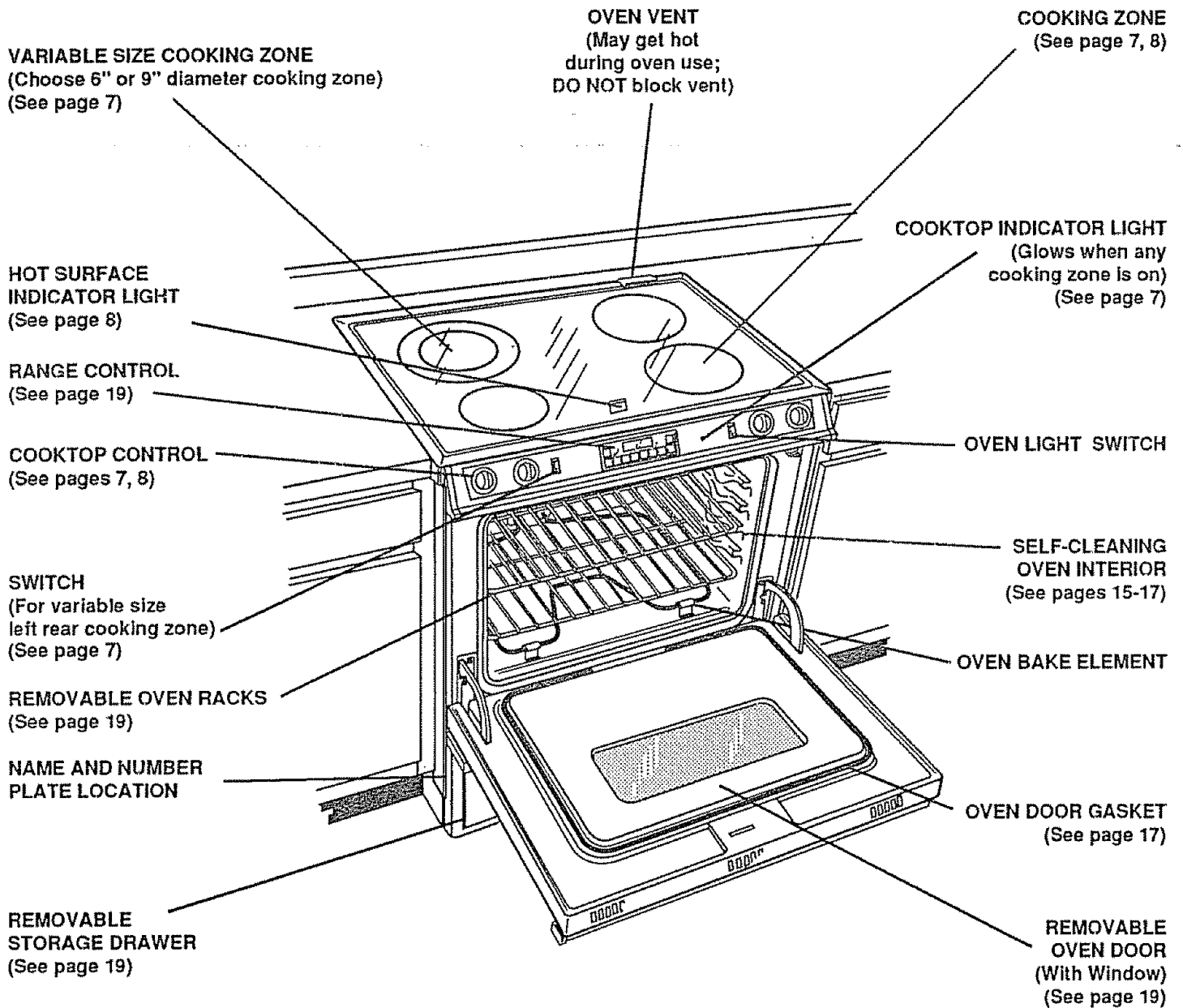

BROILER PAN and GRID
(See pages 14 & 17)

TO START THINGS COOKING COOKTOP COOKING

Before you use the cooktop for the first time, clean it with cooktop cleaner. This will leave a protective coating of silicone. The cooking zones are shown by the outlines on the glass surface of the cooktop.

COOKING ZONES

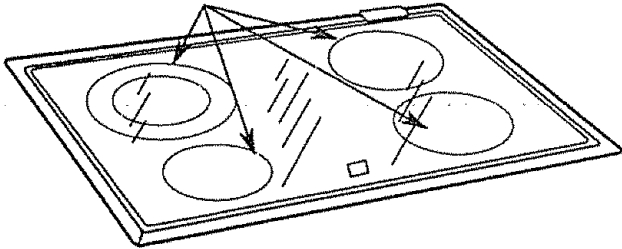

The sign near each cooktop control knob shows which element is turned on by that knob.

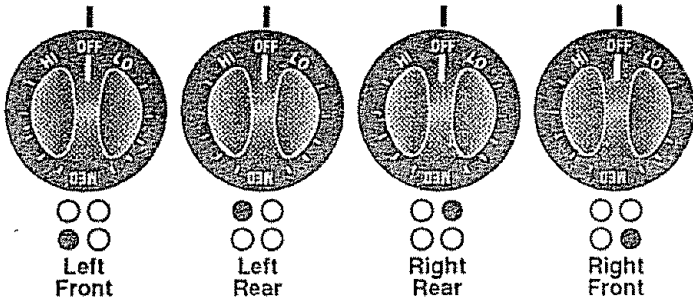

To operate cooktop controls:

1. Push to turn.

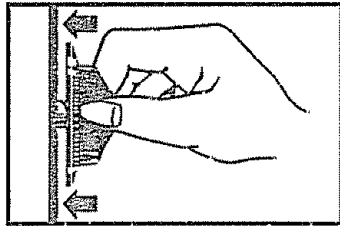

2. Set on or between marks for desired heat.

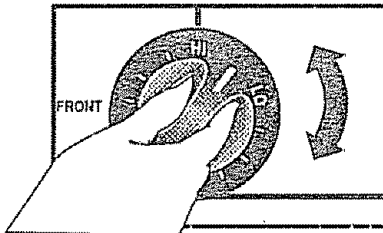

The indicator light will glow when any heating element is turned on.

The left rear element has two cooking zones:

DUEL COOKING ZONE (LEFT REAR ELEMENT ONLY)

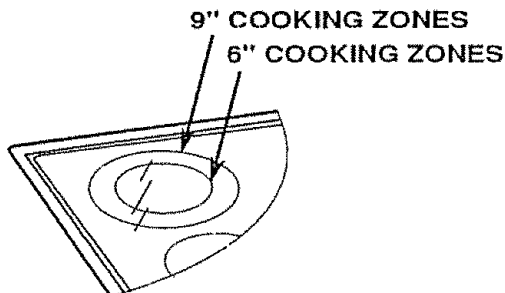

COOKTOP GUIDE TO BASIC SETTINGS

- To use the large 9" cooking area, push to turn the control knob to desired setting and push in the top portion of the rocker switch next to the control knob.
- To use the small 6" cooking area, push to turn the control knob to desired setting and push in the bottom portion of the rocker switch.

9" ZONE — ⊙

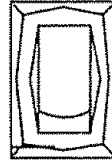

6" ZONE — ○

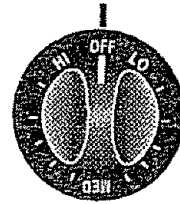

"HI"

Used for quick starts, such as bringing water to a boil.



"MED-HI"

Used for frying and rapid boiling.



"MED"

Used for slow boil and sautéing.



"MED-LO"

Used for cooking foods in small amounts of water.

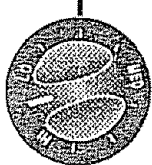

"LO"

Used for steaming foods or keeping foods at serving temperature.



When a cooking zone surface is activated, coils beneath the zone radiate heat through the glass to the utensil. The red glow of the coils will be visible through the glass. It will take the cooking zone surface a few moments to heat up. The coil cycles on and off to maintain your selected control setting.

See the **Cleaning Tips** for important information about maintaining your cooktop.

TO START THINGS COOKING (cont.)

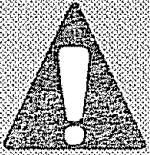

CAUTION:

The surface will retain heat after controls have been turned off. A **HOT SURFACE INDICATOR LIGHT** will glow with each individual cooking zone until the cooktop surface has cooled to a temperature of 150°F. This may take up to an hour after use. The temperature of the metal frame around the glass will also rise during cooktop use. Use caution when working around your cooktop, especially if more than one cooking zone is on or if using the cooktop for an extended period of time. Be careful not to get burned when the unit has not had time to cool after use.

Do not slide cookware on the surface as it may scratch the glass.

Never cook food directly on the glass. You must use proper cookware. Do not use the surface as a cutting board.

For best cooking results and energy efficient operation, you should use metal pans that are flat on the bottom. Match the size of the pan to the size of the cooking zone. The pan should not extend over the edge of the cooking zone more than 1".

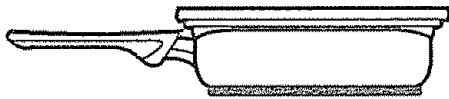

Note: A slight odor is normal when a new cooktop is used for the first time. It is caused by the heating of new parts and insulating materials and will disappear in a short time.

WOK COOKING

We recommend that you use only a flat-bottom wok. They are available at your local retail store.

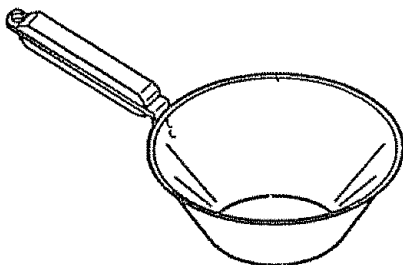

HOME CANNING TIPS

In surface cooking of foods other than canning, the use of large-diameter pots (extending more than 1" beyond edge of cooking zone) is not recommended. However, when canning with water-bath or pressure canner, large-diameter pots may be used. This is because boiling water temperatures (even under pressure) are not harmful to cooktop surfaces surrounding cooking zones.

HOWEVER, DO NOT USE LARGE DIAMETER CANNERS OR OTHER LARGE DIAMETER POTS FOR FRYING OR BOILING FOODS OTHER THAN WATER.

Most syrup or sauce mixtures — and all types of frying — cook at temperatures much higher than boiling water. Such temperatures could eventually harm cooktop surfaces surrounding cooking zones.

OBSERVE FOLLOWING POINTS IN CANNING

1. Bring water to boil on **HIGH** heat, then after boiling has begun, adjust heat to the lowest setting which maintains the boil (saves energy and best uses cooking zone).
2. Be sure canner fits over center of cooking zone. If your range does not allow canner to be centered on cooking zone, use smaller diameter pots for good canning results.
3. Flat-bottomed canners give best canning results. Be sure bottom of canner is flat or slight indentation fits snugly over cooking zone. Canners with flanged or rippled bottoms (often found in enamelware) are not recommended.

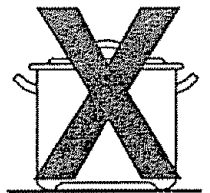
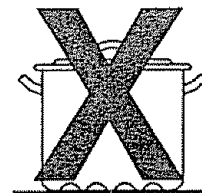

4. When canning, use recipes from reputable sources. Reliable recipes are available from the manufacturer of your canner; manufacturers of glass jars for canning, such as Ball and Kerr; and the United States Department of Agriculture Extension Service.
5. Remember, in following the recipes, that canning is a process that generates large amounts of steam. Be careful while canning to prevent burns from steam or heat.

NOTE: If your range is being operated on low power (voltage), canning may take longer than expected, even though directions have been carefully followed. The process may be improved by:

- (1) using a pressure canner, and
- (2) beginning with hot tap water when heating larger quantities of water.

RANGE CONTROL

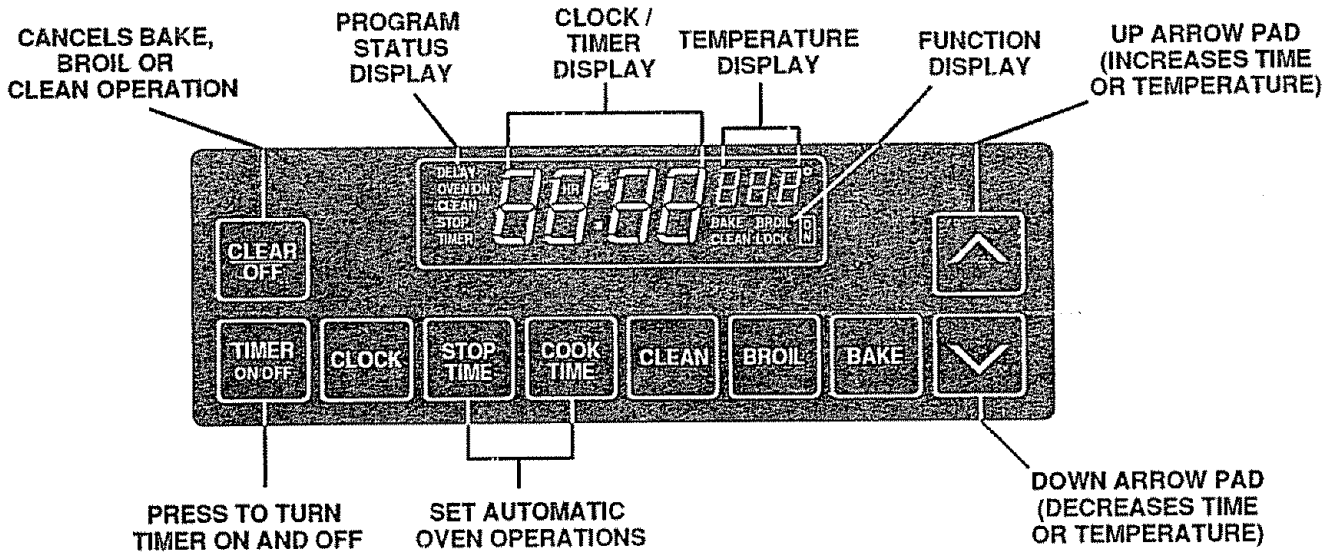

Your range is controlled with a touch. You now have the ease of setting the following operations:

- | | |
|--------------------|-------------------|
| CLOCK | TIMER |
| BAKE | DELAY BAKE |
| BROIL | CLEAN |
| DELAY CLEAN | |

The **UP** or **DOWN** arrow is used to set an amount of time or change the temperature you want to use. By pressing and holding down either pad the numbering will change quickly. By pressing and releasing either pad the numbering will change slowly.



DISPLAY:

Once you have programmed your control for any operation, you can display the setting by pressing the appropriate pad. For example, if you are using the **TIMER** and want to see the time of day, press **CLOCK**. The display will show the time of day.



TONES:

The end-of-cycle tone will sound at the end of timer use and automatic oven functions. The end-of-cycle tone is 3 short beeps followed by 1 beep every 6 seconds that repeat until you press any pad except the **UP** or **DOWN** arrow key. If you would like to eliminate the repeating beeps, push and hold **CLEAR/OFF** for ten seconds. To return the 1 beep every 6 seconds, push and hold **CLEAR/OFF** for 10 seconds.

F-CODE:

If the time display beeps continuously and flashes an "F" followed by a number, you have a function error code. Note the number after the "F". Press **CLEAR/OFF**. Allow oven to cool for 1 hour. If problem repeats, disconnect all power to the range and call for service. Advise your service technician of the number following the "F" in the display.

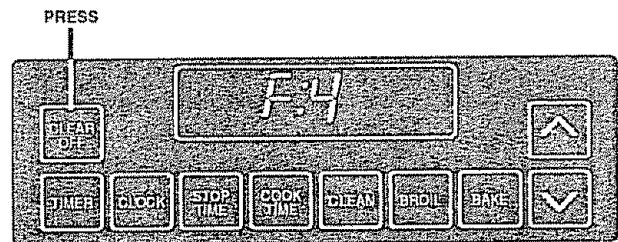

NOTE: You cannot set **BAKE**, **BROIL** or **COOK TIME** while the oven door is in the locked position. If you try, the word "DOOR" will appear in the display. The oven door lock is to be used for Self-Cleaning only.

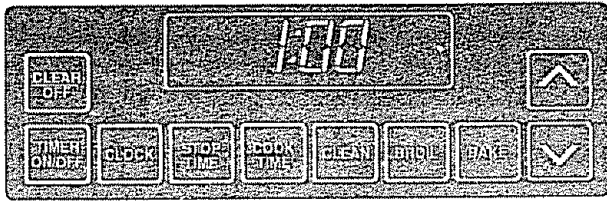

TO SET THE CLOCK:

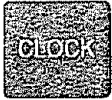

1. Press the **CLOCK** pad. "SET" and "TIME" will show in the display.
2. Press either the **UP** or **DOWN** arrow pad, until the display shows the correct time of day.

The **UP** arrow will change numbering forward, such as 1, 2, 3. The **DOWN** arrow will change numbering backwards, such as 3, 2, 1.

The clock will automatically start within one minute; or you may press the clock pad for immediate start.

TO SET THE TIMER:

The timer does not control oven operations, such as bake, broil, clean or any delay function. It allows you to set an amount of time and alerts you when that time is up. An example would be timing a three minute egg. The maximum amount of time you may set is 9 hours and 55 minutes.



1. Press the **TIMER ON/OFF** pad. "SET" and "TIMER" will flash and "HR" will show in the display.
2. Press either the **UP** or **DOWN** arrow pad to set the amount of time you want.

The timer will automatically start to count down within 4 seconds.



3. When the timer counts down to zero a tone will sound. Press the **CLOCK** pad to return to the current time of day.

TO RESET THE TIMER:

When you are setting the timer, if you pause more than 4 seconds while pressing either the **UP** or **DOWN** arrow pad, "TIMER" will stop flashing in the display and the timer will automatically start to count down. If this should happen just press the **TIMER ON/OFF** pad and you will be able to continue setting your time.



TO CANCEL THE TIMER:

While the timer is counting down, press and hold down the **TIMER ON/OFF** pad for 4 seconds, or until "TIMER" quits flashing and the current time of day returns to the display.

OVEN COOKING

GENERAL RULES

- When cooking a food for the first time in your new oven, use time given on recipes as a guide.
After you have used your oven for awhile, if you feel your oven should be hotter or cooler, you can adjust it yourself. See **TEMPERATURE ADJUSTMENTS** in this manual.
- **NO PEEKING** — Opening the door too often to check food during baking will allow heat loss and may cause poor baking results.
- There may be some odor when the oven is first used. This is caused by the heating of new parts and insulation.
- Do not cover an entire oven rack with foil. The foil can block normal heat flow and cause poor baking results. Do not place any foil directly above the bake element. Foil used on the oven bottom under the element may damage the oven surface, therefore, it should not be used.

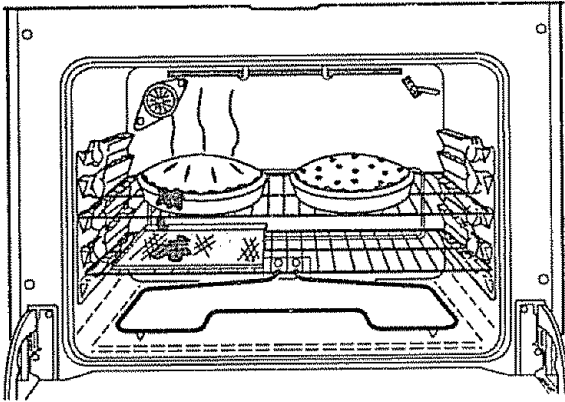

PREHEATING

- When recipes require preheating, have food nearby before you open the oven door. If the oven door is allowed to remain open for more than a brief time, the preheat temperature will be lost.
- Let the oven preheat thoroughly before cooking baked products. Watch for the **Preheat Indicator Light** to go off or listen for a preheat notification tone. If your oven is not equipped with either of these, preheat for 10 minutes before you put food in the oven.

BAKEWARE

- Cookies should be baked on flat cookie sheets without sides to allow the air to circulate properly.

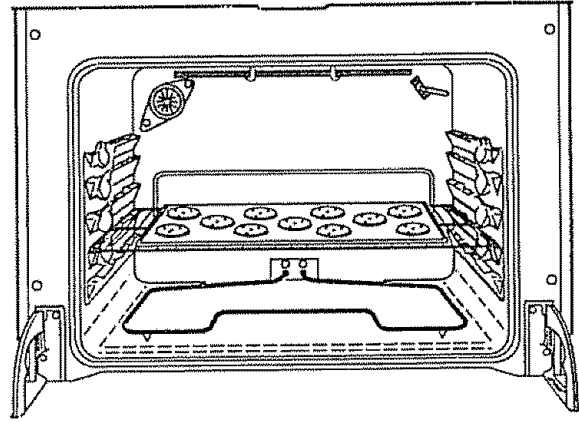

- Cakes, muffins, and quick breads should be baked in shiny pans — to reflect the heat — because they should have a light golden crust. Yeast breads and pie crusts should be baked in glass or dull (non-shiny) pans — to absorb the heat — because they should have a brown, crisp crust.
- Be sure the underside of the pan is shiny, too. Darkened undersides will absorb the heat and may cause over-browning on the bottom of your food.
- Oven temperatures should be reduced 25 degrees below recommended temperatures if exterior of pan has a dark non-stick finish, darkened by age or when baking in oven-proof glass.

BAKING:

- Always follow recipe carefully.
- Measure ingredients properly.
- Use proper pan and rack placement to obtain the best cooking results.

NOTE:

The top position is only a guide. It cannot be used as a rack position.

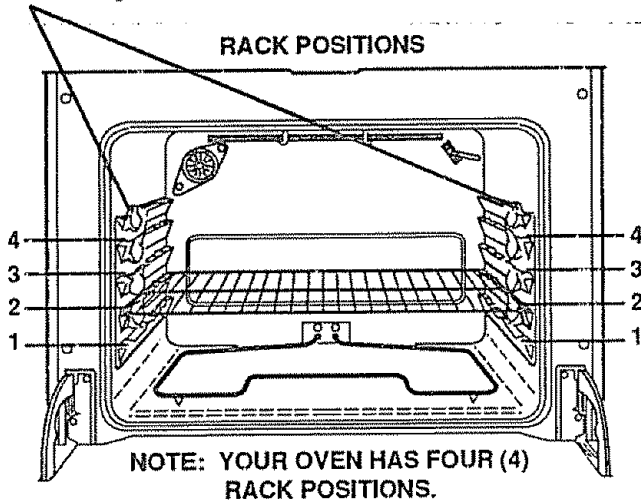

- Place pans on the oven racks with 1" to 1 1/2" of air space on all sides of each pan. Avoid overcrowding the oven.

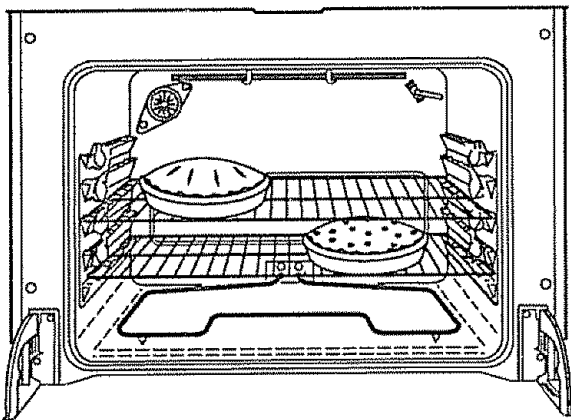

- When baking several items, stagger pans so that no pan is directly above another.
- Pans too close to each other, to oven walls or to the oven bottom block the free movement of air. Improper air movement causes uneven browning and cooking.

TO SET BAKE:



1. Press the **BAKE** pad.
2. Press either the **UP** or **DOWN** arrow pad. The last temperature used will show in the display. Use the **UP** arrow pad to increase this temperature or the **DOWN** arrow pad to decrease this temperature until you reach the temperature you prefer to use.

The oven will start to heat automatically. You will see 100 degrees showing in the upper right corner of the display. As the oven heats this temperature will change until it reaches your selected temperature, then a tone will sound.



3. When baking is complete, press the **CLEAR/OFF** pad.

TIMED BAKING:

TO SET YOUR OVEN TO BAKE FOR A SET AMOUNT OF TIME AND TURN OFF AUTOMATICALLY.



1. Press the **BAKE** pad.
2. Press either the **UP** or **DOWN** arrow pad, to set the temperature you want to use.



3. Press the **COOK TIME** pad.
4. Press either the **UP** or **DOWN** arrow pad, to set the amount of time you want foods to cook. Be sure you include your preheat time when setting this amount of time.

If you pause between steps when you are setting this function, the control will beep. This is normal. The control is letting you know you need to continue.

You should consider that food will continue to cook after control turns OFF unless you remove the food immediately.

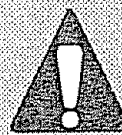

The low temperature zone of this range (between 170°F and 200°F) is available to keep cooked foods warm. Food kept longer than two hours at these low temperatures may spoil.

Fan: You will hear a fan. This is normal. The fan may continue to work even after the oven has been turned off.

TO SET YOUR OVEN FOR A DELAYED START AND AUTOMATIC STOP

While setting this operation you will not need to calculate when the oven will turn on; the control will do this for you. You will need to set the following:

1. Temperature
2. Cooking Time
3. Stop Time



1. Press the **BAKE** pad.
2. Press the **UP** or **DOWN** arrow pad to select the temperature you want.



3. Press the **COOK TIME** pad.
4. Press the **UP** arrow to select how long you want food to cook. **Be sure to include your preheat time.**



5. Press the **STOP TIME** pad.
6. Press the **UP** arrow pad to enter the time of day you want the oven to turn off. The oven will shut off automatically when the preset **STOP TIME** is reached.



7. Press the **CLOCK** pad to return the display to the current time of day.

If you pause between steps when you are setting this function, the control will beep. This is normal. The control is letting you know that you need to continue.

If you want to cancel the setting of this function, press the **CLEAR/OFF** pad.



Never let food, such as dairy products, fish, poultry, etc., sit for more than 1 hour before cooking starts when you set your oven for a delay start. Room temperature promotes the growth of harmful bacteria. Be sure the oven light is off because heat from the bulb will speed bacterial growth.

ROASTING

Roasting is cooking tender cuts of meats with dry air. It is not necessary to preheat your oven before roasting.

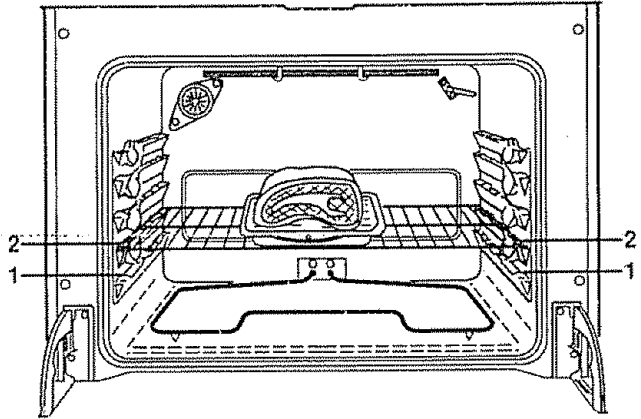

GENERAL ROASTING INSTRUCTIONS

1. Place meat (fatty side up) on a roasting rack or in a shallow pan about the same size of the meat.
2. Place pan in No.1 or No. 2 rack position.
3. Press the Bake pad.



4. Press the **UP** or **DOWN** arrow pad to select the temperature you need.



5. When roasting is finished, press the **CLEAR/OFF** pad.



Remember:

Most meats continue to cook internally after being taken out of the oven.

BROILING

BROILING TIPS:

Please note:

Your oven door should be open to the broil stop position while broiling.

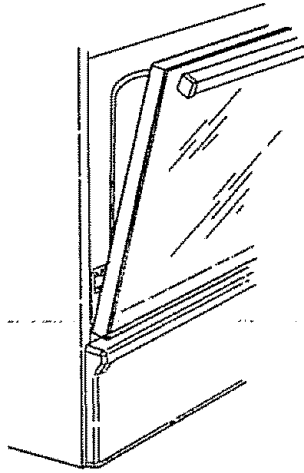

- Use only the broiler pan and grid that came with your range for broiling. They are designed for proper drainage of fat and liquids and help prevent spatter, smoke or fire.
- Do not preheat when broiling. For even broiling on both sides, start the food on a cold pan.
- Trim the outer layer of fat from steaks and chops. Slit the fatty edges to keep the meat from curling.
- For maximum juiciness, salt the first side just before turning the meat. Salt the second side just before serving.
- Brush chicken and fish with butter several times as they broil. When broiling fish, grease the grid to prevent sticking. Broil chicken skin side down. It is not necessary to turn fish.
- Never leave a soiled broiler pan in the range. Grease in the pan may smoke or burn the next time the oven is used.
- Be sure you know the correct procedure for putting out a grease fire. See the section on safety.

CAUTION:

Do not cover the entire broiler grid with a solid strip of foil. Instead mold foil tightly to grid and cut slits in foil to align with slits in the grid. Poor drainage of hot fat may cause a broiler fire.

If a fire starts, close the oven door and turn controls OFF. If fire continues, throw baking soda on the fire. Do not put water on the fire.

POSITIONING BROILER PAN

Broiling is cooking by direct heat from the broil element. Tender cuts of meat or marinated meat should be selected for broiling. For best results, steaks and chops should be at least 3/4" thick.

After placing food on the broiler pan and grid, put the pan on an oven rack in the proper position. The recommended rack position and cooking time can be found in the chart below. If your range is connected to 208 Volts, you may want to preheat and position the oven rack one position higher.

The closer the food is to the broil element, the faster the meat browns on the outside, yet stays red to pink in the center. Moving the meat farther away from the element lets the meat cook to the center while browning outside. Side one should be cooked 1 - 2 minutes longer than side two.

Food	Rack Position 4 = Highest 1 = Lowest	Total Time (minutes)
Steak – 1" Thick		
Rare	4	9-11
Medium	3	13-15
Well Done	3	21-23
Ground Beef Patties		
Medium-1" Thick	3	16-18
Medium-1/2" Thick	4	7-9
Lamb Chops – 1" Thick	3	18-21
Pork Chops – 1" Thick	3	27-29
Pork Chops - 1/2" Thick	3	16-18
Ham Slice – 1/2" Thick	3	11-12
Fish (Fillets)	3	11-13
Chicken (Pieces)	2	45-55
Frankfurters	3	8-11
Bacon	3	9-11

This chart is a general guide. The size, weight, thickness, and starting temperature of the food, as well as your own personal preference, will affect the cooking time. Times in the chart are based on the food being at refrigerator temperature. The U.S. Department of Agriculture notes: Meats cooked rare are popular, but cooking to only 140°F means some poisoning organisms may survive.

TO SET BROIL:



1. Press the **BROIL** pad.
2. Press the **UP** arrow pad once to select **LO BROIL**.

3. Press the **UP** arrow pad twice to select **HI BROIL**. "BROIL" and either "HI" or "LO" will show in the upper right corner of the display depending on your choice.

NOTE: Use **LO** broil to cook foods such as poultry or thick cuts of meat thoroughly without over-browning them.

If you do not press the up or down arrow pad, the display will go blank and you must repeat Steps 1 and 2.



4. When broiling is finished, press the **CLEAR/OFF** pad.

THE SELF-CLEAN CYCLE (3 HOURS - NORMAL CLEAN TIME)

BEFORE A CLEAN CYCLE

1. Remove the broiler pan and grid, oven racks, all utensils and any foil that may be in the oven. Do not try to clean utensils or any other objects in the oven during a self-clean cycle. If oven racks are left in the range during a clean cycle, they will darken, lose their luster and become hard to slide. If you choose to leave the racks in the oven, you can polish the edges of the racks with steel wool and apply a small amount of vegetable oil to the rack edges after the self-clean cycle. This will make the racks easier to slide.
2. Soil on the oven front frame, under the front edge of the cooktop, the door liner outside the door gasket and the front edge of the oven cavity (about 1" into the oven) will not be cleaned during a clean cycle (see illustration below). Clean these areas by hand before starting a clean cycle.

Use hot water with a soap-filled steel wool pad. We recommend a cleanser such as 'Soft Scrub®' brand or a similar cleaning product to keep white surfaces looking clean and new. After cleaning, rinse well to help prevent a brown residue from forming when the oven is heated. Buff these areas dry with a dry cloth.

OVEN LIGHT

To prolong the life of the bulb, be sure the oven light is OFF during Self-Clean.

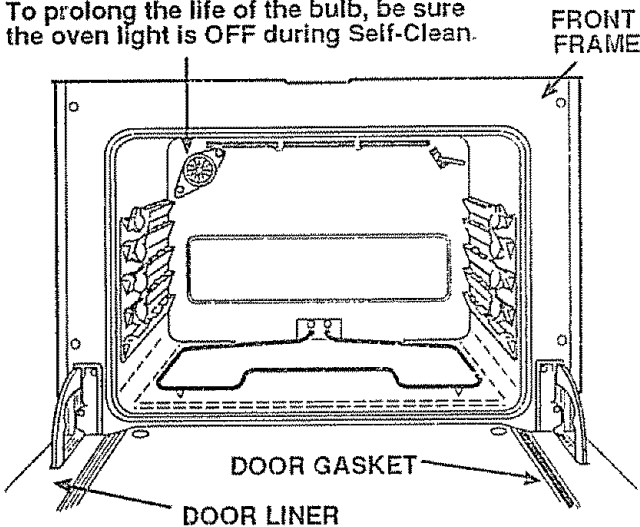

3. Wipe up heavy spillovers on the oven bottom. Too much soil may cause smoking during the clean cycle.
4. Do not rub the door gasket. The fiberglass material of the gasket has an extremely low resistance to abrasion. An intact and well fitting oven door gasket is essential for energy efficient oven operation and good baking results. If you notice the gasket becoming worn, frayed or damaged in any way or if it has become displaced on the door, you should replace the gasket.

Please Note:

The door gasket is designed to have a 5"-6" gap at the bottom of the oven door. This is to allow for proper air circulation.

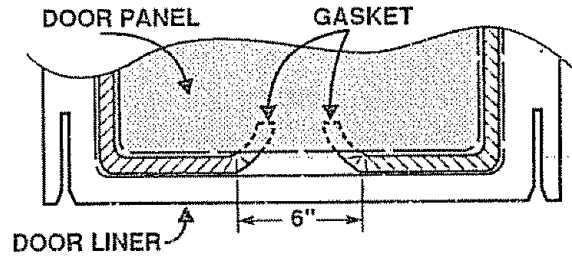

TO SET A SELF-CLEAN CYCLE:

1. Push the **CLEAN** pad. The display will show "CLEAN", "TIME", and (---).

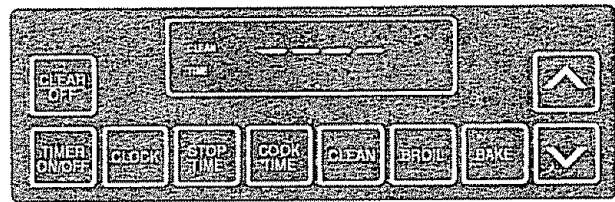

2. Press the **UP** or **DOWN** arrow pad to select the amount of time you want the oven to clean. The normal cycle is 3 hours, but you can choose between 2 and 4 hours.

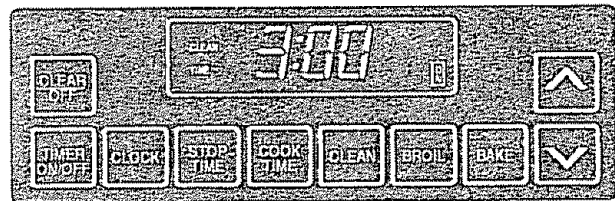

You can press the **STOP TIME** pad to see the time of day the clean cycle will be finished. Push the **CLEAN** pad to return to the countdown.

(Self-Clean continued on next page . . .)

(Self-Clean continued...)

WHEN A CLEAN CYCLE IS FINISHED:

1. Wait until the **LOCK** display goes out. The oven temperature must drop below locking temperature before the door can be unlocked.

WAIT UNTIL LOCK GOES OUT

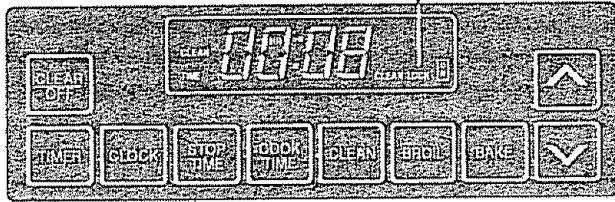

TO INTERRUPT A CLEAN CYCLE:

1. Push **CLEAR/OFF**.



Follow instructions under "WHEN A CLEAN CYCLE IS FINISHED."

TO SET A DELAYED SELF-CLEAN CYCLE:

You will not need to determine when the oven will turn on, when setting this function. The control will do this for you. You will need to set the amount of time you want your oven to clean (between 2 and 4 hours), and the time of day when you want the oven to turn off.



1. Press the **CLEAN** pad. The display will show "CLEAN", "TIME" and (---).
2. Press either the **UP** or **DOWN** arrow pad to select the amount of time you want the oven to clean. The normal cycle is 3 hours but you may choose between 2 and 4 hours.



3. Press the **STOP TIME** pad.
4. Press either the **UP** or **DOWN** arrow pad to select the time of day you want the cycle to end and the oven to turn off.

Make sure your oven light is off during a self-clean cycle to prolong the life of the bulb.

AFTER A CLEAN CYCLE

After a clean cycle, you may notice some white ash in the oven. Just wipe it up with a damp cloth or sponge.

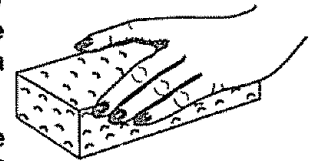

If white spots remain, remove them with a soap-filled steel wool pad. Be sure to rinse thoroughly with a vinegar and water mixture. These deposits are usually a salt residue that cannot be removed by the clean cycle.

If the oven is not clean after one clean cycle, the cycle may be repeated.

QUESTIONS AND ANSWERS

- Q. If my range control is not working, can I still self-clean my oven?
 A. No. Your **RANGE CONTROL** is used to program the oven to start and stop the self-cleaning cycle.
- Q. Can I use commercial oven cleaners on any part of my self-cleaning oven?
 A. No cleaners or coatings should be used on or around any part of this oven.
- Q. Can I clean the woven gasket around the oven door?
 A. You cannot clean the woven gasket.
- Q. Is it normal to hear "crackling sound" during cleaning?
 A. Yes. This is the metal heating and cooling.
- Q. Why do I have ash left in my oven after cleaning?
 A. Some types of soil will leave a deposit. It can be removed with a damp sponge or cloth.
- Q. What should I do if excessive smoking occurs during cleaning?
 A. This is caused by excessive soil and you should press **CLEAR/OFF**. Open windows to rid room of smoke. Allow the oven to cool for at least one hour before opening the door. Wipe up excess soil and reset the clean cycle.
- Q. Should there be any odor during the cleaning?
 A. Yes, there may be an odor during the first few cleanings. Failure to wipe out excessive soil might also cause an odor when cleaning.

CLEANING TIPS

On the following pages, all removable parts on your range are shown. Refer to those pages when cleaning your range.

Warm water, a mild detergent and a soft cloth are safe to use on all cleanable parts of your range. Do not use metal scouring pads, except where recommended.

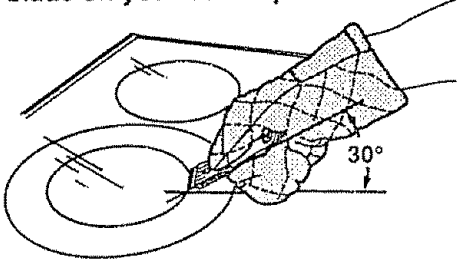
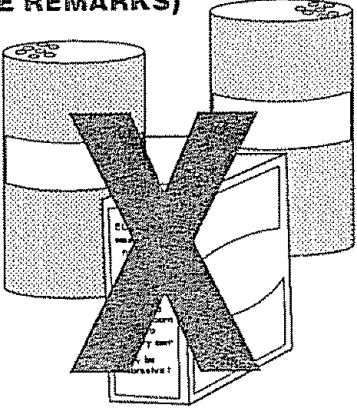
PART	CLEANING MATERIALS	REMARKS
CONTROL PANEL AND KNOBS	Detergent, warm water, soft cloth	Do not use abrasive cleaners. Knobs pull off for easier cleaning.
GLASS	<p>Sears Cooktop Cleaning Creme® (Stock No. 40079), single-edge razor scraper, soft cloth</p> <p>Do Not use a dull or nicked razor blade on your cooktop.</p>  <p>DO NOT USE ABRASIVES (SEE REMARKS)</p> 	<p>Correct and consistent cleaning is essential to maintaining your cooktop. If soil, mineral deposits from evaporated water spills or metal rub-off from aluminum cookware are not removed, they will burn onto the cooktop and cause permanent discoloration. Be sure that the cooktop is cool before cleaning. Do not use cooktop cleaner on a hot surface. The fumes can be hazardous to your health and can chemically attack the cooktop. Wipe surface clean after each use. Do not use a dish cloth or sponge to wipe up the cooktop. They may leave a film of detergent which can discolor your cooktop when heated. If this happens, remove the film with the recommended cleaner. We recommend that you use paper towels or a clean cloth which is used only for cooktop cleaning. After the cooktop has cooled, remove any crusty soil with the razor scraper. Hold the scraper at about a 30° angle to the cooktop and scrape off spot. Scrub cooktop with Sears Cooktop Cleaning Creme®. Rinse well and wipe dry. NEVER USE ANY ABRASIVE SCOURING PADS OR POWDERS ON YOUR COOKTOP. Plastic mesh pads, such as Doble®, may be used. See next page for complete cleaning instructions.</p>
OVEN INTERIOR	Detergent, warm water and/or soap-filled steel wool pad; do not use oven cleaner in or around any part of the oven.	Cleaning inside the oven need only be done as an optional touch-up between self-clean cycles. Rinse oven interior thoroughly after cleaning.
OVEN DOOR GASKET	DO NOT CLEAN	
OVEN RACKS	Detergent, warm water, scouring pad or soap-filled steel wool pad	Remove from oven to clean. Rinse thoroughly.
BROILER PAN AND GRID	Detergent, warm water, soap-filled scouring pad, plastic scouring pad, commercial oven cleaner	Remove soiled pan from oven to cool. Drain fat or drippings. Fill pan with warm water. Sprinkle grid with detergent and cover with damp cloth or paper towels. Let pan and grid soak for a few minutes. Rinse or scour as needed. Dry well. Pan and grid may be washed in a dishwasher.

GLASS-CERAMIC COOKTOP CLEANING

Cleaning of glass-ceramic cooktop is different from cleaning a standard porcelain finish.

To maintain and protect the surface of your new glass-ceramic cooktop follow these basic steps.

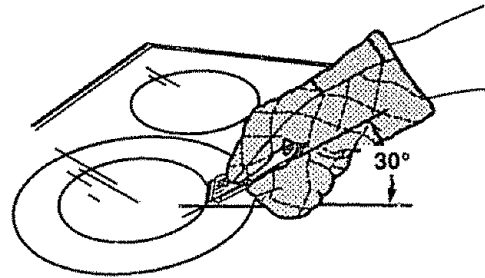

DAILY CLEANING:

Use only Cook Top Cleaning Creme® on Glass-Ceramic.

For normal, light soil:

1. Rub a small amount of Cook Top Cleaning Creme® onto soiled area using a damp paper towel. Wipe until all soil and creme are removed. Frequent cleaning leaves a protective coating which is essential in preventing scratches and abrasions.
2. Clean surface with Cook Top Cleaning Creme® after each use.

For heavy, burned-on soil:

1. Apply a few drops of Cook Top Cleaning Creme® to the cool, soiled area.
2. Using a damp paper towel, rub creme into the burned-on area.
3. Carefully scrape remaining soil with razor scraper. Hold scraper at a 30° angle against the ceramic surface.
4. If any soil remains, repeat the steps listed above. For additional protection after all soil has been removed, polish the entire surface with the Cook Top Cleaning Creme®.

NOTE: Using a razor scraper will not damage the surface if the 30° angle is maintained. **DO NOT use a dull or nicked razor blade on your cooktop. Store the razor scraper out of reach of children.**

SPECIAL CARE:

Sugar spills (such as jellies, fudge, candy syrups) or melted plastic can cause pitting of the surface of your cooktop unless the spill is removed while still hot. **Special care should be taken when removing hot substances.** Follow these instructions carefully and remove soil while spill is still hot.

1. Turn off all cooking zones affected by the spill. Remove hot utensils.
2. Wearing an oven mitt, hold the razor scraper at a 30° angle to the cooktop and scrape hot spill to a cool area outside the cooking zone.

3. With the spill in a cool area, use a dry paper towel to remove any excess. Any spill remaining should be left until the surface of the cooktop has cooled. Do not continue to use the soiled cooking zone until all of the spill has been removed. Follow the steps under Heavy Soil to continue the cleaning process.

GENERAL INFORMATION:

As the Cook Top Cleaning Creme® cleans, it leaves a protective coating on the cooktop surface. This coating helps prevent buildup of mineral deposits (water spots) and will make future cleaning easier. Dishwasher detergents remove this protective coating and therefore make the cooktop more susceptible to staining.

PRECAUTIONS:

- Most cleaners contain ammonia, chemicals and abrasives which can damage the surface of your cooktop. **Use only the Cook Top Cleaning Creme® for proper cleaning and protection of your glass-ceramic surface.**
- If you slide aluminum or copper cookware across the surface of your cooktop, they may leave metal markings which appear as scratches. If this should happen, use the razor scraper and Cook Top Cleaning Creme® to remove these markings. Failure to remove this residue immediately may leave permanent marks.
- If pots with a thin overlay of aluminum, copper, or enamel are allowed to boil dry, the overlay may bond with the glass-ceramic and leave a black discoloration. This should be removed immediately before heating again or the discoloration may be permanent.
- Use of window cleaner may leave an iridescent film on the cooktop. Cook Top Cleaning Creme® will remove this discoloration.
- Water stains (mineral deposits) are removable using Cook Top Cleaning Creme® or full strength white vinegar.

REMOVABLE OVEN RACKS

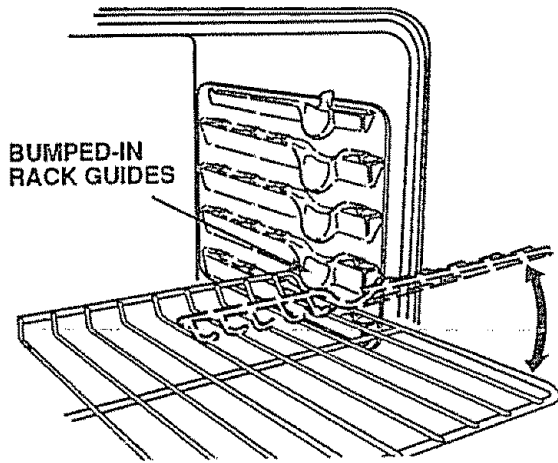

Be careful not to scratch the oven finish when installing or removing oven racks.

To install:

1. Set the raised back edge of the rack on a pair of rack guides.
2. Push the rack in until you reach the bump in the rack guide, then lift the front of the rack and push the rack all the way in.

To remove:

1. Pull the oven rack out, then up.

NOTE:

The racks are designed with stop locks. When the racks are placed correctly on the rack support and extended from the oven, the stop lock prevents the racks from tilting when you are removing food from the racks or placing food on them.

REMOVABLE OVEN DOOR

STOP BROIL POSITION

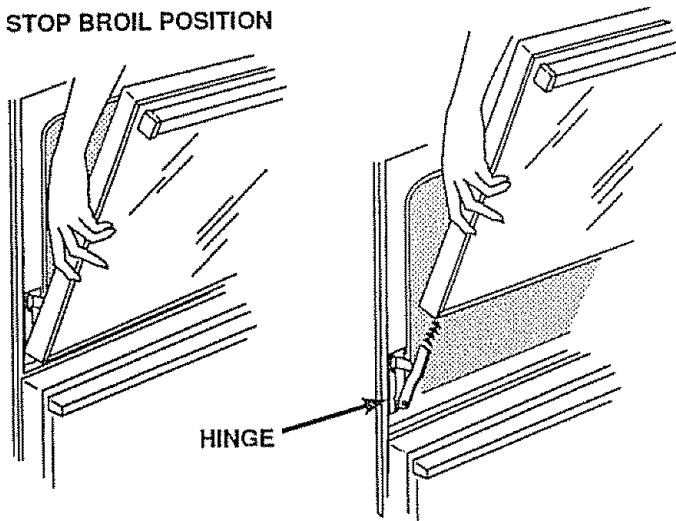

To remove:

1. Open the door to the stop position (see illustration).
2. Grasp the door at each side and lift up and off the hinges. **DO NOT** lift the door by the handle.

NOTE: When the door is removed and hinge arms are at stop position, do not bump or try to move the hinge arms. The hinges could snap back causing an injury to the hands or damage to the porcelain on the front of the range. Cover the hinges with toweling or empty towel rolls while working in the oven area.

To replace:

1. Hold the door over the hinges with the slots at the bottom edge of the door lined up with the hinges. The hinge arms must still be in the stop position.
2. Slide the door down onto the hinges as far as it will go and close the door.

REMOVABLE STORAGE DRAWER

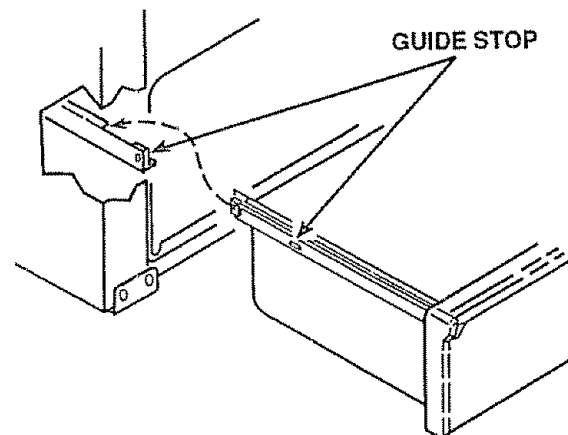

This drawer gives you space for keeping cookware and bakeware. Plastics and flammable material should not be kept in this drawer.

Do not overload the storage drawer. If the drawer is too heavy, it may slip off the track when opened. To open the drawer, grasp the center of the handle and pull straight out.

To remove: Pull drawer straight out and lift over the guide stops.

To replace: Lift over the guide stops and slide drawer into place.

REMOVABLE KNOBS

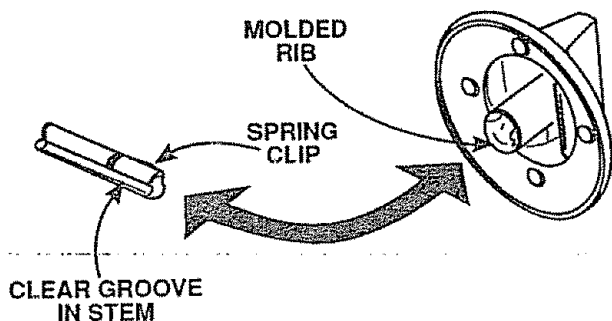

All control knobs may be removed for easy cleaning by pulling the knob straight off the stem. Be sure that the knob is in the OFF position before removal.

Hint: Slip a thin cloth (such as a handkerchief) or a piece of string under and around the knob edge and pull up.

Caution: Read these instructions carefully before replacing the knobs. Replacing the knobs improperly will damage the knobs and the spring clip on the stems. If this happens, the knobs will fit loosely.

To replace the knob:

1. The knob stem has a groove in each side. The groove on one side has a spring clip. The other groove is clear (see illustration).
2. Check the inside of the knob and find the molded rib.
3. Replace the knob by fitting the molded rib inside the knob into the clear groove on the stem.

Note: Be sure to replace knobs on correct stems from which they came.

REPLACING THE OVEN LIGHT

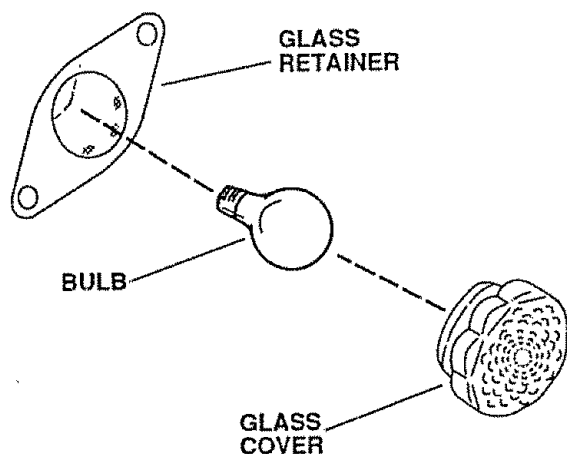

Be sure that the light switch is in the off position. Do not touch hot oven bulb. Do not touch oven bulb with wet hands. Do not wipe oven light area with wet cloth.

Never touch the electrically live collar on the bulb when replacing it.

Electrical power must be shut off if you have to replace a broken bulb.

1. Unscrew glass cover and remove.
2. Replace the bulb with a 40 watt appliance bulb.
3. Replace the cover.

Note: We recommend you use a 40 watt appliance bulb that is no longer than 3 1/2".

REMOVAL OF PACKAGING TAPE:

When packaging tape is removed from your appliance, you may find some adhesive still on the product. To remove the adhesive and assure you do not damage the finish, use an application of household liquid dishwashing detergent, mineral oil, or cooking oil. Apply with a soft cloth. **DO NOT** use a plastic pad or equivalent. Wipe dry and then apply an appliance polish to thoroughly clean and protect the surface. This procedure is also safe for the face of microwave doors and other plastics and Lexan parts.

NOTE: The plastic tape that is not removed from chrome trim on range parts **CANNOT** be removed if baked on.

BEFORE CALLING FOR SERVICE

PROBLEM	POSSIBLE CAUSE	DON'T CALL FOR SERVICE UNTIL YOU CHECK
<ul style="list-style-type: none"> • RANGE DISPLAY IS FLASHING "F" AND A NUMBER; OVEN STOPS WORKING - SURFACE WORKS 	<ul style="list-style-type: none"> • Possible range malfunction 	<ul style="list-style-type: none"> • Press CLEAR/OFF. Let range cool down for one hour. Place range back into cooking or cleaning cycle. If problem repeats, call for service.
<ul style="list-style-type: none"> • TINY SCRATCHES OR ABRASIONS ON COOKTOP (MAY APPEAR AS TINY SCRATCHES) 	<ul style="list-style-type: none"> • Use of incorrect cleaning materials • Coarse particles (salt, etc.) between cookware bottoms and cooktop. Be sure cookware bottoms and cooktop are clean before use. • Cookware with rough bottoms 	<ul style="list-style-type: none"> • Tiny scratches are not removable and do not affect cooking. In time, the scratches will become smoother and less visible.
<ul style="list-style-type: none"> • METAL MARKING ON COOKTOP (MAY APPEAR AS TINY SCRATCHES) 	<ul style="list-style-type: none"> • Sliding or scraping metal utensils and cookware across cooktop 	<ul style="list-style-type: none"> • Use recommended cooktop cleaners.
<ul style="list-style-type: none"> • DARK STREAKS AND SPECKS ON COOKTOP 	<ul style="list-style-type: none"> • Encrusted boilovers or grease spatters • Incorrect cleaning materials 	<ul style="list-style-type: none"> • Use razor scraper and follow directions in cleaning chart. • Use recommended cleaners in cleaning chart.
<ul style="list-style-type: none"> • AREAS OF DISCOLORATION ON COOKTOP 	<ul style="list-style-type: none"> • Mineral deposits from water or food 	<ul style="list-style-type: none"> • Use recommended cleaners.
<ul style="list-style-type: none"> • RANGE DOES NOT WORK; TOTALLY INOPERATIVE 	<ul style="list-style-type: none"> • No power to range 	<ul style="list-style-type: none"> • Check household circuit breaker or fuse. • Check power cord to be sure it is plugged in.
<ul style="list-style-type: none"> • OVEN DOES NOT HEAT; COOKTOP ZONES OK 	<ul style="list-style-type: none"> • Clock set incorrectly • Oven controls set incorrectly 	<ul style="list-style-type: none"> • Check clock instructions. • Check oven control instructions.
<ul style="list-style-type: none"> • COOKTOP ZONE DOES NOT WORK; OVEN OK 	<ul style="list-style-type: none"> • Improper operation of control 	<ul style="list-style-type: none"> • Be sure knob is pushed in while turning.
<ul style="list-style-type: none"> • FOODS COOK SLOWLY ON THE COOKTOP 	<ul style="list-style-type: none"> • Improper cookware 	<ul style="list-style-type: none"> • Use pans that have flat bottoms and a tight fitting lid (if applicable). Pans should match cooking zone size. Read the cooktop cooking section for complete information.
<ul style="list-style-type: none"> • FOODS DO NOT BAKE PROPERLY 	<ul style="list-style-type: none"> • Oven not preheated long enough • Improper rack or pan placement • Oven vent blocked or covered • Improper use of foil • Improper temperature setting for utensil used • Recipe not followed • Improper thermostat calibration • Range and oven rack not level • Using improper cookware 	<ul style="list-style-type: none"> • Be sure to preheat. • Maintain uniform air space around pans and utensils; see oven cooking section. • Keep vent area clear. • Use of foil not recommended. • Reduce temperature 25 degrees for glass or dull/darkened pans. • Is recipe tested and reliable? • Check oven temperature adjustment procedures. • Check the installation instructions for leveling. • See cooking hints section.

BEFORE CALLING FOR SERVICE

PROBLEM	POSSIBLE CAUSE	DON'T CALL FOR SERVICE UNTIL YOU CHECK
<ul style="list-style-type: none"> • OVEN DOES NOT WORK; TOTALLY INOPERATIVE 	<ul style="list-style-type: none"> • No power to range 	<ul style="list-style-type: none"> • Check household circuit breaker or fuse.
<ul style="list-style-type: none"> • OVEN DOES NOT HEAT 	<ul style="list-style-type: none"> • Oven controls set incorrectly 	<ul style="list-style-type: none"> • Check oven control instructions.
<ul style="list-style-type: none"> • OVEN TEMPERATURE SEEMS INACCURATE 	<ul style="list-style-type: none"> • Oven calibration • Is recipe tested and reliable? 	<ul style="list-style-type: none"> • See adjustments described after this section.
<ul style="list-style-type: none"> • FOODS DO NOT BROIL PROPERLY 	<ul style="list-style-type: none"> • Improper rack position • Oven preheated • Improper utensil used • Oven door closed during broil • Improper broiling time • 208 Voltage 	<ul style="list-style-type: none"> • Check broiler pan placement. See broiling section. • Do not preheat when broiling. • Use broiler pan and grid supplied with range. • Open door to broil stop position; see removable oven door section. • Check broiling chart in broiling section. • Use higher rack position.
<ul style="list-style-type: none"> • OVEN SMOKES 	<ul style="list-style-type: none"> • Dirty oven • Broiler pan full of grease left in oven 	<ul style="list-style-type: none"> • Check for heavy spillover. • Check pan and grid after each use.
<ul style="list-style-type: none"> • OVEN LIGHT DOES NOT WORK 	<ul style="list-style-type: none"> • Light switch in OFF position • Light bulb burned out 	<ul style="list-style-type: none"> • Check switch setting. • Check or replace light bulb; see cleaning and care instructions.

“DO-IT-YOURSELF” OVEN TEMPERATURE ADJUSTMENT

You may feel that your new oven cooks differently than the oven it replaced. We recommend that you use your new oven a few weeks to become more familiar with it, following the times given in your recipes as a guide.

Your oven has been preset to maximize cooking efficiency. If you think your new oven is too hot (burning foods), or not hot enough (foods are undercooked) you can adjust the temperature yourself. The appearance and texture of foods is a better indicator of oven accuracy than an inexpensive oven thermometer. **We do not recommend the use of inexpensive thermometers, such as those found in the grocery store, to readjust the temperature setting of your new oven.** These thermometers can vary by 20°-40°F. Also, you must open the oven door to read the thermometer and this changes the temperature of the oven.

To decide how much to change the temperature, set the oven temperature 25°F higher (if foods are undercooked) or 25°F lower (if foods are burning) than the temperature in your recipe, then bake. The results of this “test” should give you an idea of how much the temperature should be changed.

To adjust temperature follow these instructions:



1. Press the **BAKE** pad.
2. Press the **UP** arrow pad to set 550° and **IMMEDIATELY** press and **HOLD** the **BAKE** pad for 10 seconds until the clock disappears and the display shows a two digit figure.

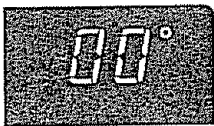

(This two digit number may vary according to the original factory setting.)



3. Press the **UP** arrow to increase your oven's temperature up to +35° **HOTTER**.

Press the **DOWN** arrow pad to decrease your oven's temperature down to -35° **COOLER**.



4. When your selection is complete press the **CLOCK** pad to return to the time of day.



Your oven's thermostat will retain this temperature adjustment until each of the four steps above are repeated. This adjustment will remain in memory even after a power failure.

You will not need to do anything else. Bake as you normally would. This adjustment will not affect broil or clean temperature.

NOTES

NOTES

KENMORE ELECTRIC RANGE WARRANTY

Dear Customer:

Our constant efforts are directed toward making sure your new Kenmore Range will arrive at your home in perfect condition and will give you proper performance. As part of these efforts, we feel it is our responsibility to provide you with this warranty for your range.



FULL ONE YEAR WARRANTY ON THE FUNCTIONING OF ALL PARTS EXCEPT GLASS PARTS

If, within one year from the date of installation, any part, other than a glass part, fails to function properly due to a defect in material or workmanship, Sears will repair or replace it, free of charge.

FULL 30-DAY WARRANTY ON GLASS PARTS AND FINISH OF PORCELAIN ENAMEL, PAINTED OR BRIGHT METAL FINISHED PARTS

If, within 30 days from the date of installation, any glass part or the finish on any porcelain enamel, painted or bright metal part is defective in material or workmanship, Sears will replace the part, free of charge.

FULL 90-DAY WARRANTY ON MECHANICAL ADJUSTMENTS

For 90 days from the date of installation, Sears will provide, free of charge, any mechanical adjustments necessary for proper operation of the range, except for normal maintenance.

If the range is subjected to other than private family use, the above warranty coverage is effective for only 90 days.

WARRANTY SERVICE IS AVAILABLE BY CONTACTING THE NEAREST SEARS SERVICE CENTER/DEPARTMENT IN THE UNITED STATES

This warranty applies only while this product is in use in the United States. This warranty gives you specific legal rights, and you may also have other rights which vary from state to state.

SEARS, ROEBUCK and CO.
Dept. 720PSO
3333 Beverly Road
Hoffman Estates, IL 60179

WE SERVICE WHAT WE SELL

"We Service What We Sell" is our assurance to you that you can depend on Sears for service because Sears service is nationwide.

Your Kenmore Range has added value when you consider that Sears has a service unit near you staffed by Sears trained technicians. . . professional technicians specifically trained on Sears appliances, having the parts, tools and equipment to ensure that we meet our pledge to you — "We Service What We Sell!"

TO FURTHER ADD TO THE VALUE OF YOUR RANGE, BUY A SEARS MAINTENANCE AGREEMENT.

Kenmore Ranges are designed, manufactured and tested for years of dependable operation. Yet, any modern appliance may require service from time to time. The Sears Warranty plus the Sears Maintenance Agreement provides protection from unexpected repair bills and assures you of enjoying maximum range efficiency.

Here's a comparative warranty and Maintenance Agreement chart showing you the benefits of a Sears Range Maintenance Agreement.

Years of Ownership Coverage		1st Year	2nd Year	3rd Year
1	Replacement of Defective Parts other than Porcelain or Glass	W	MA	MA
2	Mechanical Adjustment	90 DAYS W	MA	MA
3	Porcelain and Glass Parts	30 DAYS W	MA	MA
4	Annual Preventive Maintenance Check at your request	MA	MA	MA

W - Warranty MA - Maintenance Agreement

CONTACT YOUR SEARS SALESPERSON OR LOCAL SEARS SERVICE CENTER TODAY AND PURCHASE A SEARS MAINTENANCE AGREEMENT.

Kenmore® America's Best Selling Appliance Brand

Sold by SEARS, ROEBUCK AND CO., Hoffman Estates, IL 60179