

# Owner's Manual

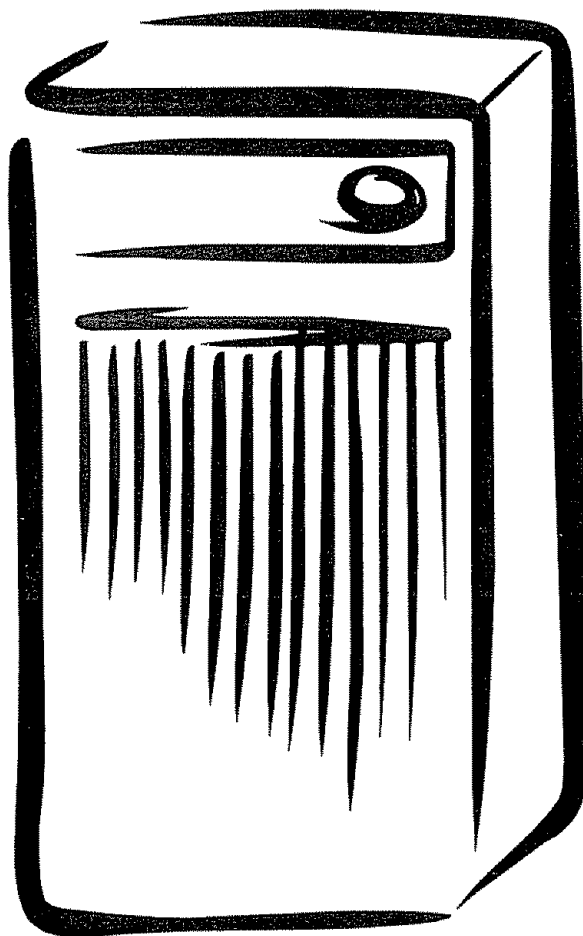

## *Dehumidifier*

Models 5751  
5840  
5830



### **CAUTION:**

Before using this dehumidifier, read this manual and follow all its Safety Rules and Operating Instructions.

- Safety
- Operation
- Care and Cleaning
- Troubleshooting
- Español
- Français

Sears, Roebuck and Co., Hoffman Estates, IL 60179 USA

P/N 327000007(9905)

## Table of Contents

Product Registration .....	2
Important Safety Instructions .....	2
Location .....	3
How It Works .....	3
Operating Steps .....	3
Dehumidifier Features .....	3-4
Removing Collected Water .....	4
Care and Cleaning .....	5
Troubleshooting .....	6
Warranty .....	7
Sears Service .....	7-8
Español .....	9
Français .....	17

## Product Registration

### Record Your Model and Serial Number

In the space provided below record the model and serial number of your dehumidifier. You will find them on the nameplate located in the center of the rear panel.

Model Number: \_\_\_\_\_

Serial Number: \_\_\_\_\_

Purchase Date: \_\_\_\_\_

## Important Safety Instructions

**Read all instructions before using this dehumidifier.** To reduce the risk of fire, electric shock, or injury to persons when using your dehumidifier, follow basic precautions, including the following:

### **⚠ WARNING For Your Safety**

Do not store or use gasoline or other flammable vapors and liquids in the vicinity of this or any other appliance. Read product labels for flammability and other warnings.

**⚠ WARNING** Avoid fire hazard or electric shock. Do not use an extension cord or adapter plug. Do not remove grounding prong from power cord.

Grounding type wall receptacle

Do not under any circumstances cut, remove, or bypass the grounding prong from this plug.

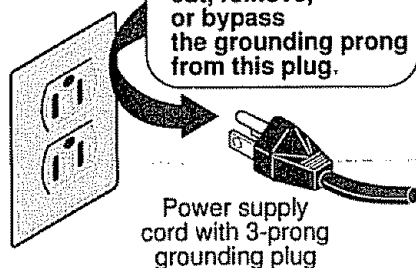

Power supply cord with 3-prong grounding plug

### **⚠ WARNING Child Safety Precautions**

- Destroy the carton, plastic bags, and any packing materials immediately after the dehumidifier is unpacked. Children should never use these items for play.
- Do not leave children unattended in an area where the appliance is operating. Do not allow them to sit or stand on the appliance.

### **⚠ WARNING Electrical Information**

- For your safety and protection, this dehumidifier is equipped with a three-prong grounding plug on the power cord. **Do not, under any circumstances, cut or remove the round grounding prong from the plug.**
- Your dehumidifier **must** be plugged directly into a properly grounded and polarized three-prong receptacle. If the wall receptacle you intend to use will not accept a three-prong plug, or if you are not sure the outlet is adequately grounded or protected by a time delay fuse or circuit breaker, have a qualified electrician install the proper outlet according to the National Electrical Code and applicable local codes and ordinances. **Do not use an extension cord or an adapter plug.**
- Never unplug the dehumidifier by pulling on the power cord. Always grip the plug firmly and pull straight out from the receptacle.
- Do not pinch, bend, or knot the power cord.

## Read and Save These Instructions

Operate dehumidifier only as instructed in this Owner's Guide. These instructions are not meant to cover every possible condition and situation that may occur. Common sense and caution **must be used** when installing, operating, and maintaining any appliance.

## Location

### Selecting a Location

#### IMPORTANT:

1. Dehumidifier must be operated in an enclosed area to be most effective. Close all doors, windows, and other outside openings to the room.
2. Rear of dehumidifier must be placed at least 8" from a wall or other obstruction so as not to restrict airflow to the coils or out of the front grill.
3. A dehumidifier operating in a basement will have little or no effect in drying an adjacent enclosed storage area, such as a closet, unless there is adequate circulation of air in and out of the area. It may be necessary to install a second dehumidifier in the enclosed area for satisfactory drying.

## How it Works

When the unit is started, the fan begins to pull moisture-laden air across the dehumidifying coils. The coils condense or draw moisture from the air, and air flows through the front grill into the room as dry, warm air. Moisture removed from air is collected in a bucket on the back of the dehumidifier.

## Operating Steps

#### To begin operating the dehumidifier, follow these steps:

1. Plug the power cord into a properly grounded 110/120 volt outlet.  
**Note:** Before operating this unit, see the "Removing Collected Water" section for proper placement of the bucket. Models will not operate if the bucket is not properly positioned on the support posts.
2. When first using the dehumidifier, turn Humidistat Control clockwise to the MAX. DRY position. The unit will run continuously at this setting.  
**Note:** The dehumidifier should be kept in operation as long as excess moisture is present in the room air.
3. Turn the Fan Control to NORMAL. The NORMAL setting is recommended for faster moisture removal.
4. Allow the dehumidifier to operate at the above settings for three to four days. After this time, adjust the controls as needed. See below.

## Dehumidifier Features

### Humidistat Control

The Humidistat Control automatically starts dehumidifier when humidity is excessive. When humidity has been reduced to the comfort level set on the control, the unit turns off.

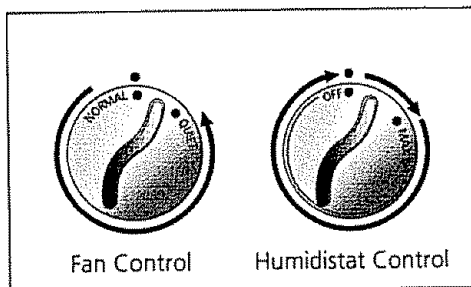

When first using dehumidifier, turn Humidistat Control clockwise to MAX. DRY, and the Fan Control to NORMAL. Unit will run continuously at this setting. Operate dehumidifier at the MAX. DRY setting for three to four days. During this time, observe the dampness conditions in the area being dried. When the dampness and dampness odors are gone, adjust Humidistat Control to the position between OFF and MAX. DRY that provides a "dryness" condition suitable to your comfort needs.

### Fan Control (some models)

The Fan Control adjusts fan speed. Turn Fan Control to NORMAL for maximum moisture removal. When humidity has been reduced to the desired level and quiet operation is preferred, set Fan Control to QUIET.

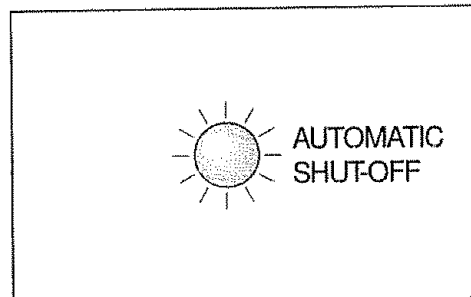

### Moisture Removal

At first, the dehumidifier will remove large amounts of moisture. It will continue to do so until the relative humidity is reduced to a point where moisture damage will not occur. Then, the amount of moisture removed from the air will be a lot less. This indicates the dehumidifier is operating effectively and is maintaining the relative humidity at the desired level. Judge the performance of the dehumidifier by the elimination of dampness and dampness odors, not by the amount of water being deposited in the bucket. When bucket has filled with water, unit will turn off. This model features an Automatic Shut-Off light that will glow until bucket is emptied and returned to the proper position.

## Dehumidifier Features (continued)

### Operating Conditions

A dehumidifier will not operate satisfactorily if room temperature is 65°F (18°C) or lower, or if the humidity in the room is low. Under these conditions, the dehumidifier should be turned off. See "Frost Control."

A dehumidifier will not eliminate frost on windows during winter. The dehumidifying coil normally operates above freezing temperatures and cannot prevent moisture from condensing on the inside of a window pane that is below freezing.

**TIP:** It may be helpful to use a dehumidifier in the kitchen or laundry area where the humidity is high. Reducing humidity in these areas may reduce frost on windows in other parts of the home.

### Frost Formation on Coils

A light coating of frost on the coils is normal when dehumidifier begins to operate. Under normal conditions, it will disappear within 60 minutes. Frost also forms on the coil when room temperature or humidity level is low.

### Frost Control

The Frost Control feature prevents frost or ice from remaining on the dehumidifying coil for an extended period of time. When frost formation occurs, this control turns off the compressor. The fan continues to run, causing any frost or ice to melt. The dehumidifier will then resume normal operation.

Frost Control is also designed to prevent excessive on-off cycling. Under certain conditions this may allow frost to remain on coil for some time before the compressor turns off and the frost is cleared.

## Removing Collected Water

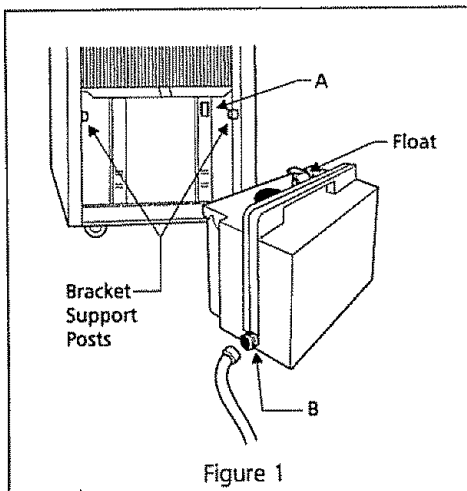

### Bucket Installation

Your unit is supplied with a closed bucket, which hangs conveniently on the back of the unit to accumulate water removed from the air. The bucket also has a built-in hose connection to carry water directly to a drain, if desired.

Your dehumidifier is equipped with an Automatic Shut-Off switch (A in Figure 1) which is activated by a float. The Auto Shut Off switch stops the unit before the bucket overflows, and turns the unit on again after the bucket is emptied and replaced.

### Direct Draining

If you want the water to flow directly to a drain, connect any standard garden hose to the bucket connection (B in Figure 1), or place the dehumidifier over the drain. A standard garden hose has a 3/4" (19 mm) diameter connection with 11 1/2 threads per inch.

**Note:** When using either of the above direct draining methods, you must first drill a 3/16" (5 mm) to 3/8" (10 mm) hole in the center of the bucket connection. This will allow water to flow freely through the connection. **Hose should not be longer than 6 to 8 feet for proper drainage.** To reseal the hose connection on the bucket, use any standard hose end cap.

**IMPORTANT: Do not drink the water collected in the bucket.**

## Care and Cleaning

### Proper Care

Before cleaning, be sure to turn off and unplug unit.

1. Dust outer cabinet with an oil-free cloth, or wash with warm water.
2. Use a vacuum cleaner and brush attachment to clean grill.

**Note:** Fan motor has been permanently lubricated at the factory.

Air passing through dehumidifier may carry quantities of dust, lint and fungus spores. Much of this matter will be deposited on the coil and then flushed away by natural drainage. If a buildup develops on coil:

1. Remove buildup when soft and wet. Brush away with a soft brush (a small paintbrush or old clothes brush).
2. **Do not allow buildup to dry and harden.** It must then be soaked and softened, and is difficult to remove.
3. If you feel you must flush coil, use a spray bottle with water. **Do not** let water enter electrical-machine compartment through the coil. **Do not spray coil with a hose.**

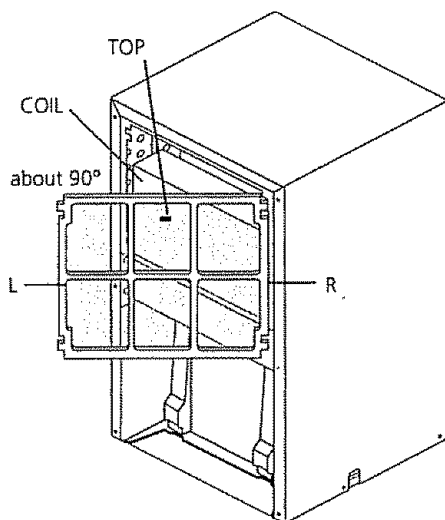

Figure 1

### Filter Cleaning

Check filter on back of unit at least once a month to see if cleaning is needed. Trapped particles in filter can build up and cause a buildup of frost on cooling coils. These conditions can reduce the efficiency of the unit.

To clean filter, wash with a mild detergent and warm water. Rinse filter well. Gently shake excess water from filter. Dry filter well before reinstalling.

### Removing Filter:

Grasp filter from top and bottom, and gently pull toward you, bowing filter slightly. Undo left side filter tabs from unit. Swing filter out toward the right. When filter is at about 90°, pull to remove. (Figure 1)

### Reinstalling Filter:

Hold filter from top and bottom. The word TOP and the letters R (right) and L (left) should be facing you. Slip right side tabs into slots on the right side first. Swing filter to the left. Bowing filter slightly, insert left side tabs into slots on the left side.

### Bucket Cleaning Instructions:

Periodic cleaning of bucket with a mild detergent and water will prevent the growth of mold, mildew and bacteria.

# Dehumidifier Troubleshooting Guide

Before calling for service, review this problem occurrence list. It may save you time and expense, because some of the occurrences are not the result of defects in materials or workmanship, and would not be covered by the warranty.

<b>OCCURRENCE</b>	<b>SOLUTION</b>
<b>DEHUMIDIFIER DOES NOT OPERATE.</b>	Plug is disconnected from outlet. Push plug firmly into wall outlet.
	House fuse blown or circuit breaker tripped. Replace fuse with time delay type or reset circuit breaker.
	The dryness level you selected has been reached. Dehumidifier automatically shuts off when selected amount of moisture has been removed from the air. If you want to remove more moisture, turn the Humidistat Control to MAX DRY. After the dehumidifier starts, reset the control to the desired setting.
	Bucket not installed properly. Hang bucket on support posts. See "Removing Collected Water."
	Water in the bucket has reached its preset level. Dehumidifier automatically turns off when this occurs. Empty bucket and return bucket to position.
Dehumidifier is not turned on. Turn the Humidistat Control to MAX DRY.	
<b>DEHUMIDIFIER RUNS TOO MUCH.</b>	Windows or doors near dehumidifier are open to outdoors. Close all windows or doors to outside.
	Area to be dehumidified is too large. Check with your dealer to see if capacity is adequate.
	Air movement through dehumidifier is blocked. Grill may be dirty. Use brush attachment of vacuum cleaner to clean grill. Dehumidifying coil on back of unit may be dirty. See "Care and Cleaning." Dehumidifier must be placed in a space that does not restrict air flowing into the rear coil or out of the front grill. (See page 2.)
	Dehumidifier has been installed or restarted recently. The higher the moisture in the room, the longer the dehumidifier will operate.
	Humidistat Control is set at MAX DRY. Dehumidifier will not turn off if Humidistat Control is at MAX DRY.
<b>DEHUMIDIFIER EMITS AN UNPLEASANT ODOR.</b>	The bucket is dirty. Clean per instructions on page 5.
	Coils are dirty. Clean per instructions on page 5.
	Filter is dirty. Clean per instructions on page 5.
<b>DEHUMIDIFIER IS OPERATING BUT ROOM IS NOT DRY ENOUGH.</b>	Humidistat Control is set too low. Turn the Humidistat Control to a higher setting.
	Dehumidifier has been installed or restarted recently. The higher the moisture in the room air, the longer it takes for the room air to become dry.
	Dehumidifier does not have sufficient clearance to operate. Air flow to front and rear grills is blocked. See "Selecting a Location," page 3.
	Room temperature is too low. Unit will not operate satisfactorily if the room temperature is below 65°F (18°C). See "Operating Conditions," page 3.
Refer to causes under DEHUMIDIFIER RUNS TOO MUCH.	
<b>FROST APPEARS ON COILS ABOVE BUCKET OR DRIP TRAY.</b>	Dehumidifier has been turned on recently. This is normal due to refrigerant rushing through the coil. Frost will usually disappear within 60 minutes.
	Room temperature is too low. Unit will not operate satisfactorily if room temperature is below 65°F (18°C). See "Operating Conditions."
<b>FAN-LIKE NOISE.</b>	Air is moving through the dehumidifier. This is a normal sound.

---

## Sears Dehumidifier Warranty

### **Full One Year Warranty on Dehumidifier**

For one year from date of purchase, if this Dehumidifier is operated and maintained according to the owner's instructions attached to, or furnished with, the product. Sears will repair this Dehumidifier free of charge, if defective in material or workmanship.

### **Full Five Year Warranty on Sealed Refrigeration System**

For five years from date of purchase, when this Dehumidifier is operated and maintained according to owner's instructions attached to, or furnished with the product, Sears will repair the sealed refrigeration system (consisting of refrigerant, connecting tubing, and compressor motor) free of charge, if defective in material or workmanship.

### **Warranty (Exclusions)**

1. Damage to product caused by misuse, fire, flood, acts of nature.
2. Damages due to commercial use or from product being used in multi-user dwellings.
3. Damage to Sealed System\* caused by salt corrosion or chemical reaction to copper/steel.

\* Sealed System (compressor, condenser, evaporator, drier and tubing.)

### **Warranty Service**

Warranty Service is available by returning this Dehumidifier to the nearest Sears Service Center in the United States.

This warranty applies only while this Dehumidifier is used in the United States.

This warranty gives you specific legal rights, and you may also have other rights which vary from state to state.

**Sears Roebuck and Co.**  
**DEPT. 817WA**  
**Hoffman Estates, IL 60179**

---

## Sears Service

"**We Service What We Sell**" is our assurance that you can depend on Sears for service. Your Kenmore Dehumidifier has added value when you consider that Sears has service units nationwide, staffed with professional technicians trained on all appliances Sears sells. They have the knowledge and skills, tools, parts and equipment to ensure our pledge to you that "We Service What We Sell."

### **Sears Maintenance Agreement**

Maintain the value of your Dehumidifier with a Sears Maintenance Agreement. Kenmore Dehumidifiers are designed, manufactured, and tested for years of dependable operation. Yet any appliance may require service from time to time. The Sears Maintenance Agreement offers you an outstanding service program for your Kenmore Dehumidifier.

### **The Sears Maintenance Agreement:**

- Is your way to buy tomorrow's service at today's prices.
- Eliminates repair bills resulting from normal use.
- Allows for as many service calls as you need.
- Provides an annual Preventive Maintenance Check at your request to keep your Dehumidifier in proper running condition.

**For more information, call 1-800-827-6655**

---

## Déshumidificateur Sears Garantie

### Garantie complète de un an sur le déshumidificateur

Pendant un an, à compter de la date d'achat, et à condition que ce déshumidificateur soit utilisé et entretenu conformément au manuel de l'utilisateur joint au produit ou fourni avec ce dernier. Sears réparera ce déshumidificateur sans aucuns frais, en cas de défaut de matériau ou de fabrication.

### Garantie complète de cinq ans sur les systèmes de réfrigération scellés

Pendant cinq ans, à compter de la date d'achat, et à condition que ce déshumidificateur soit utilisé et entretenu conformément au manuel de l'utilisateur joint au produit ou fourni avec ce dernier, Sears réparera le système de réfrigération scellé (comprenant le réfrigérant, le tube de raccordement et le moteur du compresseur) sans aucuns frais, en cas de défaut de matériau ou de fabrication.

### Garantie (exclusions)

1. Les dommages infligés au produit par une mauvaise utilisation, un incendie, une inondation ou un cas de force naturelle.
2. Les dommages infligés par une utilisation commerciale ou par une utilisation en collectivité du produit.
3. Les dommages infligés au système scellé\* par la corrosion saline ou par une réaction chimique au cuivre/à l'acier.

\*Système scellé (compresseur, condensateur, évaporateur, sécheur et tube)

### Service de réparation sous garantie

Le service de réparation sous garantie est disponible en renvoyant le déshumidificateur au centre de service Sears le plus proche aux États-Unis.

Cette garantie est valable uniquement lorsque ce déshumidificateur est utilisé aux États-Unis.

Cette garantie vous accorde des droits juridiques spécifiques, et vous pouvez également bénéficier d'autres droits en fonction de l'État dans lequel vous habitez.

Sears Roebuck and Co.  
DEPT. 817WA  
Hoffman Estates, IL 60179 E.U.

---

## Service de réparation Sears

« Nous réparons tout ce que nous vendons » est notre assurance que vous pouvez toujours compter sur nous pour le service technique. Votre déshumidificateur Kenmore prend donc plus de valeur si vous considérez le nombre de centres de réparation Sears à travers les États-Unis et le professionnalisme de nos techniciens capables de réparer tous les appareils électroménagers vendus dans nos magasins. Ils possèdent l'expertise, les outils, les pièces et l'équipement nécessaires pour réparer tout ce que nous vendons.

### Contrat d'entretien Sears

Préservez la valeur de votre déshumidificateur avec un contrat d'entretien Sears. Les déshumidificateurs Kenmore sont conçus, fabriqués et testés pour fonctionner de manière fiable pendant de nombreuses années. Cependant, tous les électroménagers doivent être vérifiés de temps à autre. Le contrat d'entretien Sears vous offre un programme d'entretien unique pour votre déshumidificateur Kenmore.

### Le contrat d'entretien Sears :

- Vous permet de payer les futurs frais d'entretien à leur coût actuel.
- Élimine les factures de réparations résultant d'une utilisation normale.
- Vous permet de faire autant d'appels que vous voulez au service de réparation.
- Offre une vérification annuelle préventive à votre demande pour que votre déshumidificateur continue à fonctionner de façon optimale.

Pour plus d'informations, composez le 1-800-827-6655



**For the repair or replacement parts you need**

Call 7am - 7 pm, 7days a week

**1-800-366-PART**

(1-800-366-7278)

.....

**For in-home major brand repair service**

Call 24 hours a day, 7days a week

**1-800-4-MY-HOME™**

(1-800-366-7278)

.....

**For the location of a  
Sears Parts and Service Center  
in your area**

Call 24 hours a day, 7days a week

**1-800-488-1222**

.....

**For more information on purchasing a  
Sears Maintenance Agreement  
or to inquire about an existing Agreement**

Call 9 am - 5 pm, Monday-Saturday

**1-800-827-6655**



The Service Side of Sears<sup>SM</sup>

Sears, Roebuck and Co., Hoffman Estates, IL 60179, U.S.A.