

SONY®

Cyber-shot

Digital Still Camera

Cyber-shot Handbook

DSC-T70/T75/T200

Before operating the unit, please read this Handbook thoroughly together with the “*Instruction Manual*” and the “*Cyber-shot Step-up Guide*”, and retain them for future reference.

▼CLICK!



Table of contents



Basic Operations



Using functions for shooting



Using functions for viewing



Customizing the settings



Viewing images on a TV



Using your computer



Printing still images



Troubleshooting



Others



Index

Notes on using your camera

Notes on the types of “Memory Stick” that can be used (not supplied)



“Memory Stick Duo”:
you can use a “Memory Stick Duo” with your camera.

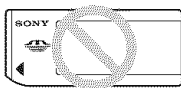

“Memory Stick”:
you cannot use a “Memory Stick” with your camera.

Other memory cards cannot be used.

- For details on “Memory Stick Duo”, see page 121.

When using a “Memory Stick Duo” with “Memory Stick” compatible equipment

You can use the “Memory Stick Duo” by inserting it into the Memory Stick Duo Adaptor (not supplied).

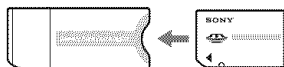

Memory Stick Duo Adaptor

Notes on the battery pack

- Charge the battery pack (supplied) before using the camera for the first time.
- The battery pack can be charged even if it is not completely discharged. Also, even if the battery pack is not fully charged, you can use the partially charged capacity of the battery pack as is.
- If you do not intend to use the battery pack for a long time, use up the existing charge and remove it from your camera, then store it in a cool, dry place. This is to maintain the battery pack functions.
- For details on the usable battery pack, see page 123.

Carl Zeiss lens

This camera is equipped with a Carl Zeiss lens which is capable of reproducing sharp images with excellent contrast.

The lens for this camera has been produced under a quality assurance system certified by Carl Zeiss in accordance with the quality standards of Carl Zeiss in Germany.

Notes on the LCD screen and lens

- The LCD screen is manufactured using extremely high-precision technology so over 99.99% of the pixels are operational for effective use. However, there may be some tiny black points and/or bright points (white, red, blue or green in color) that constantly appear on the LCD screen. These points are normal in the manufacturing process and do not affect the recording in any way.

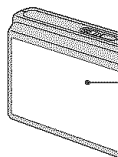

- If water droplets or other liquids splash on the LCD screen and make it wet, immediately wipe off the screen with a soft cloth. Leaving liquids on the LCD screen surface can harm the quality and cause a malfunction.
- Exposing the LCD screen or the lens to direct sunlight for long periods may cause malfunctions. Be careful when placing the camera near a window or outdoors.
- Do not press against the LCD screen. The screen may be discolored and that may cause a malfunction.
- Images may trail across on the LCD screen in a cold location. This is not a malfunction.
- Be careful not to bump the lens, and be careful not to apply force to it.

The pictures used in this Handbook

The photographs used as examples of pictures in this Handbook are reproduced images, and are not actual images shot using this camera.

On illustrations

Illustrations used in this Handbook are of DSC-T200 unless noted otherwise.

Table of contents

Notes on using your camera	2
Basic techniques for better images	8
Focus – Focusing on a subject successfully	8
Exposure – Adjusting the light intensity	10
Color – On the effects of lighting	11
Quality – On “image quality” and “image size”	12
Flash – On using the flash	14
Identifying parts	15
Indicators on the screen	17
Operate the touch panel	22
Changing the screen display	23
Using the internal memory	25















Basic Operations

Shooting images easily (Auto Adjustment mode)	26
Setting Image size/Self-timer/Flash mode/Macro recording	28
Setting Focus/Metering Mode/ISO/EV	30
Viewing images	35
Deleting images	37
Learning the various functions – HOME/Menu	39
Menu items	42

Using functions for shooting

Switching the shooting mode	43
Shooting images using Scene Selection	44
Shooting menu	47
REC Mode: Selecting the continuous shooting method	
EV: Adjusting the light intensity	
Focus: Changing the focus method	
Metering Mode: Selecting the metering mode	
White Balance: Adjusting the color tones	
Color Mode: Changing the vividness of the image or adding special effects	
Flash Level: Adjusting the amount of flash light	
Red Eye Reduction: Reducing the red-eye phenomenon	
Face Detection: Detecting the face of subject	
SteadyShot: Selecting the anti-blur mode	
Setup: Selecting the shooting settings	

Using functions for viewing

<i>Playing back images from the HOME screen</i>	54
 (Single Image): Playing back a single image	
 (Image Index): Playing back a list of images	
 (Slideshow): Playing back a series of images	
<i>Viewing menu</i>	57
 (Retouch): Retouching still images	
 (Paint): Painting on still images	
 (Multi Resizing): Changing the image size according to usage	
 (Wide Zoom Display): Displaying still images in 16:9	
 (Slideshow): Playing back a series of images	
 (Delete): Deleting images	
 (Protect): Preventing accidental erasure	
DPOF : Adding a Print order mark	
 (Print): Printing images using a printer	
 (Rotate): Rotating a still image	
 (Select Folder): Selecting the folder for viewing images	
 (Volume Settings): Adjusting the volume	
<i>Painting or putting stamps on still images (Paint)</i>	65

Customizing the settings











<i>Customizing the Manage Memory feature and the Settings</i>	67
 <i>Manage Memory</i>	68
 Memory Tool — Memory Stick Tool	68
Format	Change REC.Folder
Create REC.Folder	Copy
 Memory Tool — Internal Memory Tool	70
Format	
 <i>Settings</i>	71
 Main Settings — Main Settings 1	71
Beep	Calibration
Function Guide	Housing
Initialize	
 Main Settings — Main Settings 2	73
USB Connect	Video Out
COMPONENT	TV TYPE

Table of contents

 Shooting Settings — Shooting Settings 1.....	75
AF Illuminator	AF Mode
Grid Line	Digital Zoom
 Shooting Settings — Shooting Settings 2.....	78
Auto Orientation	Smile Level
Auto Review	
 Clock Settings.....	79
 Language Setting	80

Viewing images on a TV

Viewing images on a TV	81
Viewing images by connecting your camera to a TV with the supplied cable for multi-use terminal	81
Viewing an image by connecting your camera to a HD TV.....	83

Using your computer

Enjoying your Windows computer.....	85
Installing the software (supplied)	87
On the “Picture Motion Browser” (supplied).....	89
Copying images to your computer using the “Picture Motion Browser”	90
Copying images to a computer without “Picture Motion Browser”	94
Viewing image files stored on a computer with the camera copying to the “Memory Stick Duo”	96
Using the “Music Transfer” (supplied).....	97
Using your Macintosh computer	98
Viewing “Cyber-shot Step-up Guide”	100

Printing still images

How to print still images	101
Printing images directly using a PictBridge compliant printer	102
Printing at a shop	105

Troubleshooting

Troubleshooting.....	107
Warning indicators and messages	117

Others

Using your camera abroad — Power sources.....	120
On the “Memory Stick Duo”	121
On the battery pack	123
On the battery charger	124
On Cyber-shot Station.....	125

Index

Index.....	127
------------	-----

Basic techniques for better images

Focus

Exposure

Color

Quality

Flash

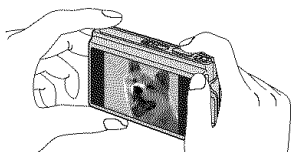

This section describes the basics so you can enjoy your camera. It tells you how to use various camera functions such as the HOME screen (page 39), the menus (page 41), and so on.

Focus

Focusing on a subject successfully

When you press the shutter button halfway down, the camera adjusts the focus automatically (Auto Focus). Remember to press the shutter button only halfway down.

Press the shutter button fully down suddenly.

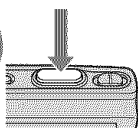

Press the shutter button halfway down.

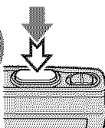

AE/AF lock indicator flashing → lit/beeps



Then press the shutter button fully down.

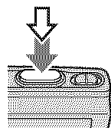

To shoot a still image difficult to focus on → [Focus] (page 31)

If the image looks blurred even after focusing, it may be because of camera shake. → See "Hints for preventing blur" (as follows).

Hints for preventing blur

The camera moved accidentally when you took the picture. This is called “Camera shake.” On the other hand, if the subject moved when you took the picture, it is called “subject blur.”

Camera shake



Cause

Your hands or body shake while you hold the camera and press the shutter button, and the entire screen is blurred.

What you can do to reduce the blurring

- Use a tripod or place the camera on a flat, stable surface to hold the camera steady.
- Shoot with a 2-second delay self-timer and stabilize your camera by holding your shooting arm firmly at your side after pressing the shutter button.

Subject blur





Cause

Even though the camera is steady, the subject moves during the exposure so the subject looks blurred when the shutter button is pressed.

What you can do to reduce the blurring

- Select **ISO** (High Sensitivity) mode in Scene Selection.
- Select a higher ISO sensitivity to make the shutter speed faster, and press the shutter button before the subject moves.

Notes

- The anti-blur function is enabled in the factory default settings so that the camera shake is reduced automatically. However, this is not effective for subject blur.
- Besides, camera shake and subject blur occur frequently under low-light or slow shutter speed conditions, such as those encountered in  (Twilight) or  (Twilight Portrait) mode. In that case, shoot with the above tips in mind.

Exposure *Adjusting the light intensity*

You can create various images by adjusting the exposure and the ISO sensitivity. Exposure is the amount of light that the camera will receive when you release the shutter.

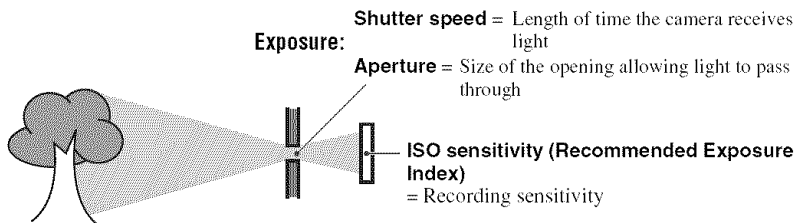

Overexposure
= too much light
Whitish image



Correct exposure



Underexposure
= too little light
Darker image

The exposure is automatically set to the proper value in the auto adjustment mode. However, you can adjust it manually using the functions below.

Adjusting EV:

Allows you to adjust the exposure determined by the camera (pages 24, 34).

Metering Mode:

Allows you to change the part of the subject to be measured to determine the exposure (page 33).

Adjusting ISO Sensitivity (Recommended Exposure Index)

ISO sensitivity is a speed rating for recording media that incorporates an image sensor that receives light. Even when the exposure is the same, images differ depending on the ISO sensitivity.

To adjust the ISO sensitivity, see page 34.



High ISO sensitivity

Records a bright image even when shooting in a dark location, reducing blur with a high shutter speed.

However, the image tends to become noisy.



Low ISO sensitivity

Records a smoother image.





However, when the exposure is insufficient, the image may become darker.

Color

On the effects of lighting

The apparent color of the subject is affected by the lighting conditions.

Example: The color of an image affected by light sources

Weather/lighting	Daylight	Cloudy	Fluorescent	Incandescent
Characteristics of light	White (standard) 	Bluish 	Green-tinged 	Reddish 

The color tones are adjusted automatically in the auto adjustment mode.

However, you can adjust color tones manually with [White Balance] (page 49).

Quality On “image quality” and “image size”

A digital image is made up of a collection of small dots called pixels.

If it contains a large number of pixels, the picture becomes large, it takes up more memory, and the image is displayed in fine detail. “Image size” is shown by the number of pixels.

Although you cannot see the differences on the screen of the camera, the fine detail and data processing time differ when the image is printed or displayed on a computer screen.

Description of the pixels and the image size

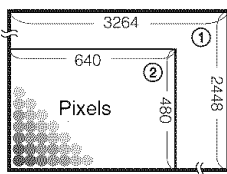

- ① Image size: 8M
 $3264 \text{ pixels} \times 2448 \text{ pixels} = 7,990,272 \text{ pixels}$
- ② Image size: VGA
 $640 \text{ pixels} \times 480 \text{ pixels} = 307,200 \text{ pixels}$

Selecting the image size for use (page 13)

Pixel

Many pixels (Fine image quality and large file size)













Few pixels (Rough image quality but small file size)

Example: Printing in up to A3 size

Example: An attached image to be sent by e-mail



Basic techniques for better images

The default settings are marked with ✓.

	Image size	Guidelines	No. of images	Printing
✓	 8M (3264×2448)	For prints up to A3(11×17")	Less 	Fine 
	 3:2*1 (3264×2176)	Shoot in 3:2 aspect ratio	 	 
	 5M (2592×1944)	For prints up to A4(8.5×11")		
	 3M (2048×1536)	For prints up to 10×15 cm (4×6") or 13×18 cm(5×7")		
	 VGA (640×480)	Shoot at small image size for e-mail attachments		
	 16:9*2 (1920×1080)	Shoot in HDTV aspect ratio		

*1 Images are recorded in 3:2 aspect ratio, same as photograph printing paper or postcards, etc.

*2 Both edges of the image may be cut off when printing (page 114).

	Movie image size	Frame/Second	Usage guidelines
	 FINE 640(Fine) (640×480)	Approx. 30	Shoot high quality movie for display on TV
✓	 STD 640(Standard) (640×480)	Approx. 17	Shoot standard quality movie for display on TV
	 320 (320×240)	Approx. 8	Shoot at small image size for e-mail attachments

- The larger the image size, the higher the image quality.
- The more frames per second you played back, the smoother playback can be.

Flash

On using the flash

The eyes of the subject may come out red, or fuzzy white circular spots may appear when using the flash. These phenomena can be reduced by taking the following steps.

The “Red-eye phenomenon”

This is caused by the reflection of flash light off the blood vessels of the retina of the subject’s eyes because the pupils of the subject’s eyes are wide open in a dark place.

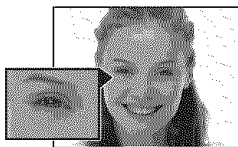
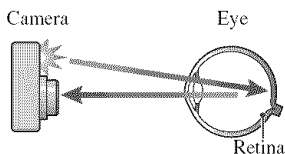

How can the “Red-eye phenomenon” be reduced?

- Set [Red Eye Reduction] to [On] (page 52).
- Select **iSO** (High Sensitivity)* mode in Scene Selection (page 44). (The flash is turned off automatically.)
- When the eyes of the subject turn out red, correct the image with [Retouch] on the viewing menu (page 57) or with the supplied software “Picture Motion Browser”.

The “White circular spots”

This is caused by particles (dust, pollen, etc.) in the air, which when they are close to the lens, can be accentuated by the camera’s flash.

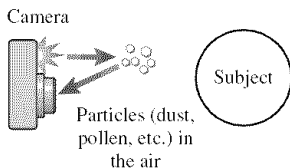

How can the “White circular spots” be reduced?

- Light the room and shoot the subject without a flash.
- Select **iSO** (High Sensitivity)* mode in Scene Selection. (The flash is turned off automatically.)

* Even though you selected **iSO** (High Sensitivity) mode in Scene Selection, the shutter speed might be slower under low-light conditions, or in a dark place. In that case, use a tripod or hold your shooting arm firmly at your side after pressing the shutter button.

Identifying parts

DSC-T200

See the pages in parentheses for details of operation.

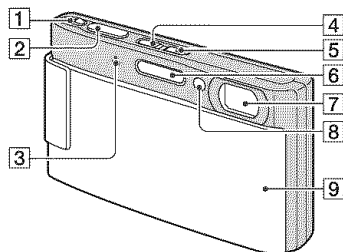

- 1 Zoom (W/T) lever (28)
- 2 Shutter button (27)
- 3 Microphone
- 4 ► (Playback) button (35)
- 5 POWER button/POWER lamp
- 6 Flash (29)
- 7 Lens
- 8 AF illuminator (75)/Self-timer lamp (28)/Smile shutter lamp (46)
- 9 Lens cover

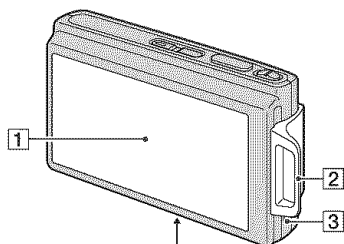

Bottom

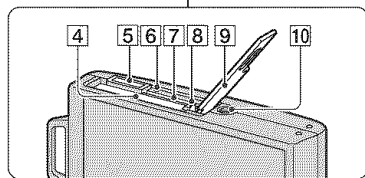

- 1 LCD screen/Touch panel (22, 23)
- 2 Hook for wrist strap/Grip
- 3 Speaker
- 4 Battery insertion slot
- 5 Multi connector
Used in the following situations:
 - Making a USB connection between the camera and the computer.
 - Making a connection to audio/video input jacks on a TV.
 - Making a connection to a PictBridge compliant printer.
- 6 Access lamp
- 7 “Memory Stick Duo” slot
- 8 Battery eject lever
- 9 Battery/“Memory Stick Duo” cover
- 10 Tripod receptacle
 - Use a tripod with a screw length of less than 5.5 mm (7/32 inch). You will be unable to firmly secure the camera to tripods having screws longer than 5.5 mm (7/32 inch), and may damage the camera.

DSC-T70/T75

See the pages in parentheses for details of operation.

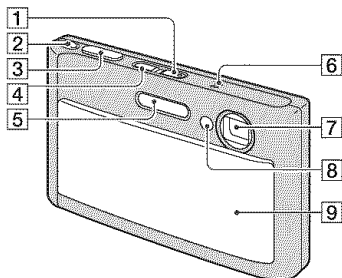

- 1** POWER button/POWER lamp
- 2** Zoom (W/T) lever (28)
- 3** Shutter button (27)
- 4** (Playback) button (35)
- 5** Flash (29)
- 6** Microphone
- 7** Lens
- 8** AF illuminator (75)/Self-timer lamp (28)/Smile shutter lamp (46)
- 9** Lens cover

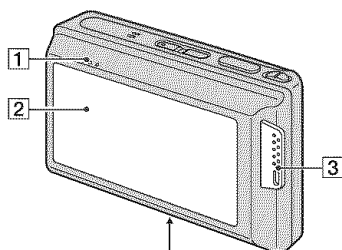

Bottom

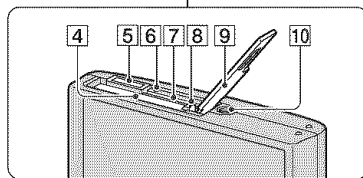

- 1** Speaker
- 2** LCD screen/Touch panel (22, 23)
- 3** Hook for wrist strap/Grip
- 4** Battery insertion slot
- 5** Multi connector
Used in the following situations:
 - Making a USB connection between the camera and the computer.
 - Making a connection to audio/video input jacks on a TV.
 - Making a connection to a PictBridge compliant printer.
- 6** Access lamp
- 7** “Memory Stick Duo” slot
- 8** Battery eject lever
- 9** Battery/“Memory Stick Duo” cover
- 10** Tripod receptacle
 - Use a tripod with a screw length of less than 5.5 mm (7/32 inch). You will be unable to firmly secure the camera to tripods having screws longer than 5.5 mm (7/32 inch), and may damage the camera.

Indicators on the screen

Touch [DISP] on the screen to change to the display selection screen (page 23). See the pages in parentheses for details of operation.

When shooting still images

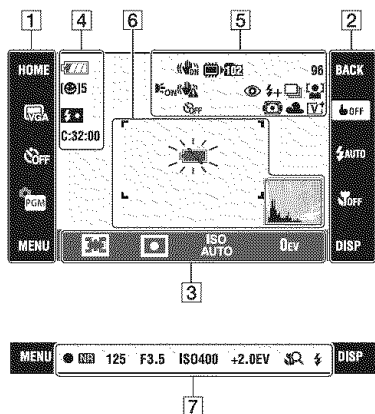

When shooting movies

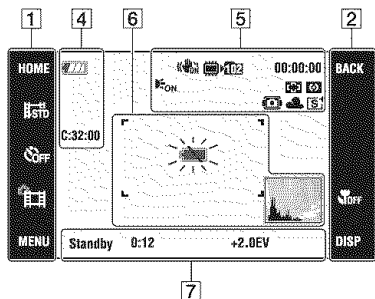

Screen operation

You can change the settings by touching the following: **1**, **2**, **3**.

- Touching an icon displays the guide about the touched item. To hide this guide, touch [?] (page 22).



1

Display	Indication
HOME	Displays the HOME screen.
	Image size settings (13)
	Self-timer settings (28)
	Shooting mode settings (43)
	Shooting mode (Scene Selection) settings (44) <ul style="list-style-type: none"> Touch SCN in the shooting mode settings to select the Scene Selection mode.
MENU	Displays the MENU screen.

2

Display	Indication
BACK	Backs to the previous screen.
	This cancels the focusing on the subject selected by the touch operation.
	Flash mode settings (29)
	Macro/Close focus settings (30)
DISP	Changes the screen display.





3

Display	Indication
 0.5m 1.0m 3.0m 7.0m ∞	AF mode/focus preset settings (31, 32) • [0.5m] is available in the DSC-T70/T75 only.
	Metering mode settings (33)
ISO AUTO	ISO number settings (34)
0EV	Exposure Value settings (34)



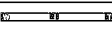

Screen indicators











Screen indicators **4** to **7** show the current setting status.

4

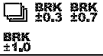
Display	Indication
	Battery remaining
 15	Smile shutter (number of still images)
	Zoom scaling (28, 76)
x1.3 S Q P Q	
	Flash charging
C:32:00	Self-diagnosis display (117)



5

Display	Indication
	SteadyShot (53) • Displayed when the shutter button is pressed halfway down in the default settings.
	Recording Media ("Memory Stick Duo," internal memory)
 102	Recording folder (68) • This does not appear when using internal memory.
	AF illuminator (75)

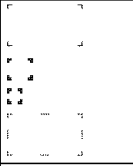

Display	Indication
	Vibration warning • Indicates vibration may prevent you from shooting clear images due to insufficient lighting. Even if the vibration warning appears, you can still shoot images. However, we recommend that you turn on the anti-blur function, using the flash for better lighting or using a tripod or other means to stabilize the camera (page 9).
	Self-timer (28)
96	Number of recordable images
00:00:00	Recordable time (h:m:s)
	Red-eye reduction (52)
	Flash level (51)
	Recording mode (47)
	Face Detection (52)
	Touch AF indicator (26)
	Housing (72)
	White balance (49)
	Color mode (50)

Indicators on the screen

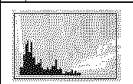
6

Display	Indication
	AF range finder frame (31)
	Low battery warning (117)
	Histogram (24)

7

Display	Indication
	AE/AF lock (27)
NR	NR slow shutter <ul style="list-style-type: none"> When the shutter speed drops below a certain speed in low light conditions, the NR (Noise Reduction) slow shutter function is activated automatically to reduce the picture noise.
125	Shutter speed
F3.5	Aperture value
ISO400	ISO number (34)
+2.0EV	Exposure Value (34)
	Macro/Close focus (30) <ul style="list-style-type: none"> When [Display Setup] is set to [Image Only], the current settings are displayed.
	Flash mode (29) <ul style="list-style-type: none"> When [Display Setup] is set to [Image Only], the current settings are displayed.
Standby REC	Standby a movie/Recording a movie
0:12	Recording time (m:s)

When playing back still images

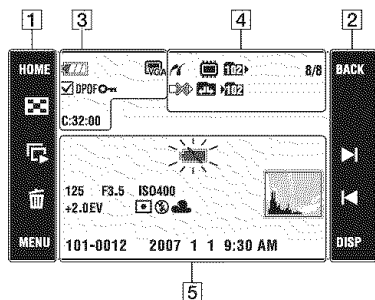

When playing back movies

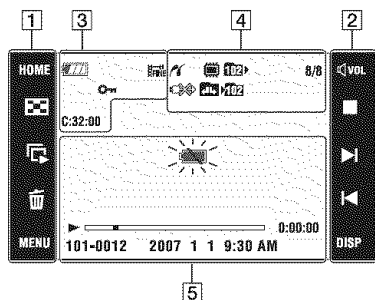

Screen operation

You can change the settings by touching the following: **1**, **2**.

1

Display	Indication
HOME	Displays the HOME screen.
	Changes to index mode.
	Plays back the slide show.
	Deletes the image.
MENU	Displays the MENU screen.
	Selects the playback folder.
	Returns to the single image screen from the index screen.

2

Display	Indication
BACK	Backs to the previous screen.
	Adjusts the volume (35).
	Stop
	Playback
	Playback zoom (36)
	Turns on/off.
	Displays the previous/next image.
	Fast forward/Rewind
DISP	Changes the screen display.







Screen indicators

Screen indicators **3** to **5** show the current setting status.







3

Display	Indication
	Battery remaining
	Image size (13)
	Check mark
DPOF	Print order (DPOF) mark (105)
	Protect (61)
Qx2.0	Playback zoom (36)
C:32:00	Self-diagnosis display (117)

4

Display	Indication
	PictBridge connecting (103)
	Playback Media ("Memory Stick Duo," internal memory)
	Playback folder (64) <ul style="list-style-type: none"> This does not appear when using internal memory.
8/8 12/12	Image number/Number of images recorded in selected folder
	PictBridge connecting (104) <ul style="list-style-type: none"> Do not disconnect the cable for multi-use terminal while the icon is displayed.
	Change folder (64) <ul style="list-style-type: none"> This does not appear when using internal memory.
	Recording folder (68) <ul style="list-style-type: none"> This does not appear when using internal memory.

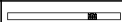
5

Display	Indication
	Low battery warning (117)
125	Shutter speed
F3.5	Aperture value
ISO400	ISO number (34)
+2.0EV	Exposure Value (34)
	Metering mode (33)
	Flash
AWB 	White balance (49)
	Playback (35)
	Playback bar
0:00:00	Counter
101-0012	Folder-file number (64)
2007 1 1 9:30 AM	Recorded date/time of the playback image
	Histogram (24) <ul style="list-style-type: none">  appears when histogram display is disabled.

Operate the touch panel

This LCD screen also displays the buttons for operating the camera (touch panel).

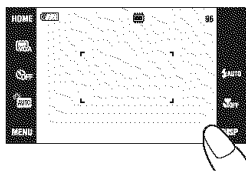
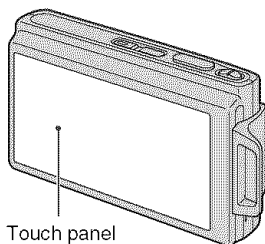

1 Press the **POWER** button or slide the lens cover downward.

2 Touch the buttons on the screen lightly with your finger.

On the touch panel buttons

- When the item you want to set is not on the screen, touch ▲/▼ to change the page.
- You can return to the previous screen by touching [BACK].
- Touching [?] displays the guide about the touched item. To hide this guide, touch [?] again.

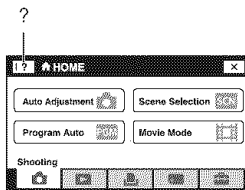

- To operate the touch panel, press it lightly with your finger or the supplied paint pen.
- Do not press the touch panel with any pointed object other than the supplied paint pen.
- Do not press against the LCD screen more than necessary.
- When the top right of the screen is touched, the icons will momentarily disappear. Taking your finger off the screen will make the icons reappear.

Changing the screen display

Touch [DISP] on the screen to change to the display selection screen.

- Settings other than [LCD Brightness] can be made separately for shooting and playback.
- In index mode, you can set the number of images displayed.

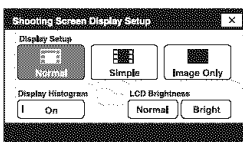
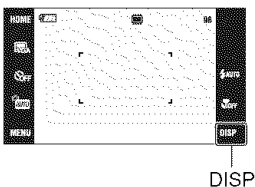

[Display Setup]

This sets whether or not to display the icons on the screen.

Normal

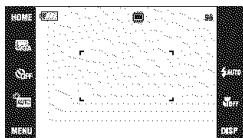

Simple

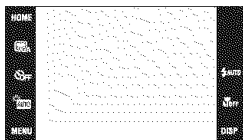
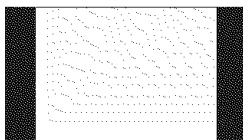

Image Only

- [Image Only] is suitable for shooting or playback in the 16:9 aspect ratio.
- During playback, touch the right or left side of the screen to display the next/previous image, and touch the center to display the guide.



[LCD Brightness]

This sets the backlight brightness.

- When viewing images in bright outside light if [LCD Brightness] is set to [Normal], reset to [Bright].

However, the battery power may decrease faster under such condition.

[Display Histogram]

This sets whether or not to display the histogram on the screen.

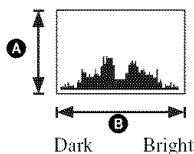

A histogram is a graph showing the brightness of an image. The graph display indicates a bright image when skewed to the right side, and a dark image when skewed to the left side.

- A** Number of pixels
- B** Brightness

- The histogram also appears when playing back a single image, but you cannot adjust the exposure.
- The histogram does not appear in the following situations:
 - While shooting
 - When the menu is displayed.
 - When recording movies
 - During playback
 - When the menu is displayed.
 - In index mode
 - When you are using playback zoom.
 - When you are rotating still images.
 - During playback of movies
- A large difference in the histogram displayed when shooting and during playback may occur when:
 - The flash strobes.
 - The shutter speed is slow or fast.
- The histogram may not appear for images recorded using other cameras.

Using the internal memory

The camera has approximately 31 MB of internal memory. This memory is not removable. Even when there is no "Memory Stick Duo" inserted in the camera, you can record images using this internal memory.

- Movies with the image size set to [640(Fine)] cannot be recorded using the internal memory.

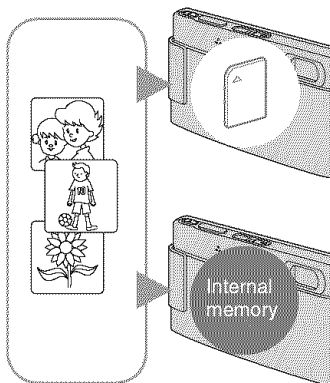

When a "Memory Stick Duo" is inserted

[Recording]: Images are recorded on the "Memory Stick Duo".

[Playback]: Images on the "Memory Stick Duo" are played back.

[Menu, Settings, etc.]: Various functions can be performed on images on the "Memory Stick Duo".

When there is no "Memory Stick Duo" inserted

[Recording]: Images are recorded using the internal memory.

[Playback]: Images stored in the internal memory are played back.

[Menu, Settings, etc.]: Various functions can be performed on images in the internal memory.

On image data stored in the internal memory

We recommend that you copy (back up) data without error using one of the following methods.

To copy (back up) data on a "Memory Stick Duo"

Prepare a "Memory Stick Duo" with sufficient capacity, then perform the procedure explained in [Copy] (page 69).

To copy (back up) data on a hard disk of your computer

Perform the procedure on pages 90 to 95 without a "Memory Stick Duo" inserted in the camera.

- You cannot copy image data on a "Memory Stick Duo" to the internal memory.
- By connecting the camera and a computer with a cable for multi-use terminal, you can copy data stored in the internal memory to a computer. However you cannot copy data on a computer to the internal memory.

Shooting images easily (Auto Adjustment mode)

The procedure for shooting images using the basic functions is given below.

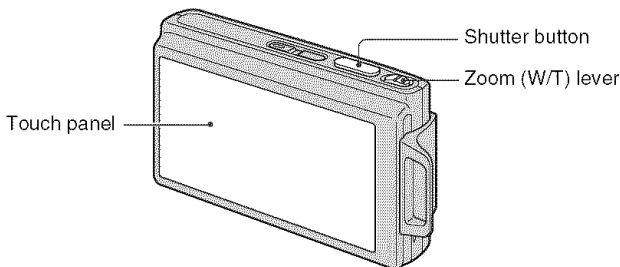

1 Open the lens cover.

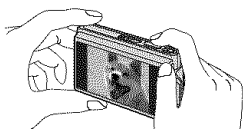

2 Hold the camera steady, keeping your arm at your side.



Position the subject in the center of the focus frame or touch the point for focusing.

💡 You can touch the screen to select the point to bring into focus.

Touching the subject on the touch panel displays a frame, and then pressing the shutter button halfway down brings the frame into focus. If there is a face in the frame, in addition to the focus, the brightness and hue are also automatically optimized.

-  is displayed if a face is detected in the touched position or  is displayed if an object other than a person's face is detected.
- You cannot use this function when using the digital zoom and Close focus mode.
- You can also use this function in  (Soft Snap) mode.
- If you touch outside the selectable focus range, the selectable range is displayed.

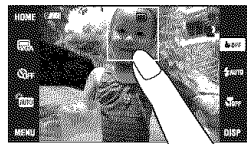

3 Shoot with the shutter button.

- Press and hold the shutter button halfway down to focus.
The ● (AE/AF lock) indicator (green) flashes, a beep sounds, the indicator stops flashing and remains lit.
- Press the shutter button fully down.



AE/AF lock indicator

Shooting movies

Touch [HOME], then touch (Shooting) → [Movie Mode] (page 39).
Or, touch the shooting mode setting icon, then touch (Movie Mode).

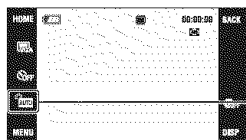

Shooting mode setting icon

If you shoot a still image of a subject that is difficult to focus on

- The shortest shooting distance is approx. 50 cm (19 3/4 inches) (W side), 80 cm (31 1/2 inches) (T side) (DSC-T200)/approx. 50 cm (19 3/4 inches) (DSC-T70/T75). Shoot in the close-up (Macro) mode or Close focus mode when you shoot a subject closer than the shortest shooting distance (page 30).
- When the camera cannot focus on the subject automatically, the AE/AF lock indicator changes to flash slowly and the beep does not sound. In addition, the AF range finder frame disappears. Recompose the shot and focus again.

Subjects difficult to focus on are:

- Distant from the camera and dark
- The contrast between the subject and its background is poor.
- Seen through glass
- Moving fast
- Reflective light or with a lustrous finish
- Flashing
- Backlit

W/T Using the zoom

Slide the zoom (W/T) lever to the T side to zoom and slide to the W side to return.

- When the zoom scale exceeds 5× (DSC-T200)/3× (DSC-T70/T75), the camera uses the Digital Zoom function.

For details on the [Digital Zoom] settings and the image quality, see page 76.

- The camera zooms slowly while shooting a movie.
- When the Face Detect function is activated, you cannot use the Digital Zoom function.
- While using the Digital Zoom, you cannot focus by touching the screen.

Setting Image size/Self-timer/Flash mode/Macro recording

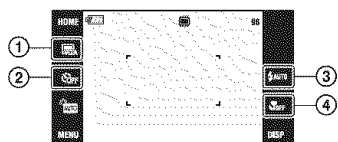

- ① Changing the image size
- ② Using the self-timer
- ③ Selecting a flash mode for still images
- ④ Shooting close-up

Changing the image size

Touch the image size setting icon on the screen. Touch the desired item, then [BACK].
For details on the image size, see page 12.

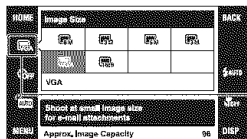
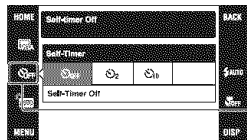

Image size setting icon

Using the self-timer

Touch the self-timer setting icon on the screen. Touch the desired item, then [BACK].



Self-timer setting icon

Self-Timer Off (OFF): Not using the self-timer

Self-Timer 10sec (S₁₀): Setting the 10-second delay self-timer

Self-Timer 2sec (S₂): Setting the 2-second delay self-timer

Shooting images easily (Auto Adjustment mode)

Press the shutter button, the self-timer lamp flashes, and a beep sounds until the shutter operates.

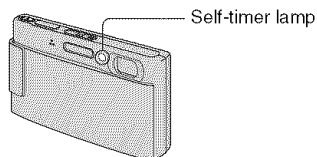

To cancel, touch **OFF**.

- Use the 2-second delay self-timer to prevent blur of an image made by the shaking of the camera when pressing the shutter button.

Flash (Selecting a flash mode for still images)

Touch the flash mode setting icon on the screen. Touch the desired item, then [BACK].

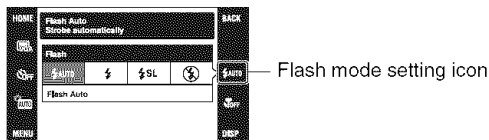

Flash Auto (📷**AUTO**): Strobes when there is insufficient light or backlight (default setting)

Flash On (📷)

Slow Synchro (Flash forced on) (📷**SL**): The shutter speed is slow in a dark place to clearly shoot the background that is out of flash light.

Flash Off (📷)

- The flash strobes twice. The first time is to adjust the light quantity.
- While charging the flash, 📷 is displayed.

Macro/Close focus (Shooting close-up)

Touch the Macro/Close focus mode setting icon on the screen. Touch the desired item, then [BACK].

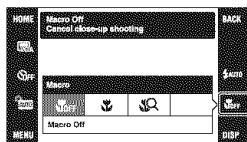

Macro/Close focus mode setting icon

Macro Off (OFF)

Macro On (ON): W side

DSC-T200: Approx. 8 cm or farther (3 1/4 inches or farther)

DSC-T70/T75: Approx. 8 cm or farther (3 1/4 inches or farther)

T side

DSC-T200: Approx. 80 cm or farther (31 1/2 inches or farther)

DSC-T70/T75: Approx. 25 cm or farther (9 7/8 inches or farther)

Close focus enabled (Q): Locked to the W side: Approx. 1 to 20 cm (13/32 to 7 7/8 inches)

Macro

- Setting the zoom all the way to the W side is recommended.
- The in-focus range becomes narrow, and the complete subject may not entirely be in focus.
- The Auto Focus speed drops.

Close focus

- Use this mode to shoot at even closer distances than (Macro On) recording.
- The optical zoom is locked to the W side and cannot be used.
- You cannot shoot images in the Burst or Bracket mode (page 47).
- You cannot use the Face Detection feature when you shoot images in the Close focus mode.
- This mode is cancelled if you turn off the power or switch the mode to another one.

Setting Focus/Metering Mode/ISO/EV

The Focus, Metering Mode, ISO and EV icons appear only when the shooting mode is set to PGM.

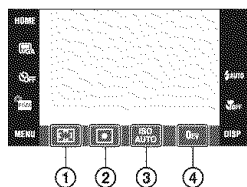







- ① Changing the focus method
- ② Selecting the metering mode
- ③ Selecting a luminous sensitivity
- ④ Adjusting the light intensity

Focus: Changing the focus method

You can change the focus method. Use the menu when it is difficult to get the proper focus in auto focus mode.

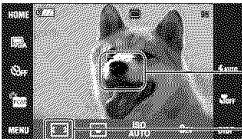
- When the shooting mode is set to , [Focus] appears in [MENU].

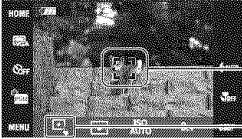
	 (Multi AF)	<p>Focuses on a subject in all ranges of the finder frame automatically.</p> <ul style="list-style-type: none"> • This mode is useful when the subject is not in the center of the frame.  <p>AF range finder frame (Only for still image)</p> <p>AF range finder frame indicator</p>
	 (Center AF) (Only for still image)	<p>Focuses on a subject in the center of the finder frame automatically.</p> <ul style="list-style-type: none"> • Using together with the AF lock function lets you shoot in the desired image composition.  <p>AF range finder frame</p> <p>AF range finder frame indicator</p>
	 (Spot AF) (Flexible Spot AF) (Only for still image)	<p>By moving the AF range finder frame to wherever you like on the screen, you can focus on an extremely small subject or a narrow area.</p> <ul style="list-style-type: none"> • To set the Flexible Spot AF, see page 32. • This is useful when you shoot using a tripod and the subject is out of the center area. • When shooting a moving subject, take care to hold the camera steady so that the subject does not deviate from the range finder frame.  <p>AF range finder frame</p> <p>AF range finder frame indicator</p>

Shooting images easily (Auto Adjustment mode)

0.5 m (DSC-T70/T75 only)	Focuses on the subject using a previously set distance to the subject. (Focus preset) <ul style="list-style-type: none">When shooting a subject through a net or through window glass, it is difficult to get the proper focus in auto focus mode. In these cases, use of the focus preset is convenient.
1.0 m	
3.0 m	
7.0 m	
∞ (unlimited distance)	

- AF stands for Auto Focus.
- Distance setting information in “Focus Preset” is approximate. If you zoom to the T side or point the lens up or down, the error increases.
- When you use Digital Zoom or AF Illuminator, the normal AF range finder frame is disabled and a new AF range finder frame is displayed by a dotted line. In this case, the priority of AF movement is given to subjects around the center of the frame.

How to use the [Spot AF]

- Set the shooting mode setting icon to **PGM** (Program Auto), then touch [BACK].
- Touch the focus mode setting icon →  (Spot AF).
- Touch [BACK] to turn off the menu.



- Touch where you want to focus the shot.

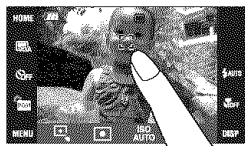





- If you touch outside the selectable focus range, the selectable range is displayed.
-

Metering Mode: Selecting the metering mode

Selects the metering mode that sets which part of the subject to measure to determine the exposure.

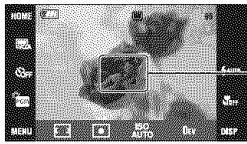
- When the shooting mode is set to , [Metering Mode] appears in [MENU].

✓	 (Multi)	Divides into multiple regions and measures each region. The camera determines a well-balanced exposure (Multi-pattern metering).
	 (Center)	Measures the center of the image, and determines the exposure based on the brightness of the subject there (Center-weighted metering).
	 (Spot) (Only for still image)	<p>Measures only a part of the subject (Spot metering).</p> <ul style="list-style-type: none"> This function is useful when the subject is backlit or when there is strong contrast between the subject and the background. <div data-bbox="412 543 676 695" style="text-align: center;">  </div> <p style="text-align: right;">Spot metering cross hairs Positions on the subject</p>

- For details on the Exposure, see page 10.
- When using spot metering or center-weighted metering, setting [Focus] to  (Center AF) is recommended to focus on the metering position (page 31).

ISO: Selecting a luminous sensitivity



Low ISO sensitivity



High ISO sensitivity

Sets the ISO sensitivity.

✓	ISO AUTO (Auto)	When taking a picture in a dim location or of a moving subject, raising the ISO sensitivity (higher number) can reduce blurring. However, higher ISO sensitivities results in increased noise. Set the ISO sensitivity according to the shooting conditions.
	ISO 80	
	ISO 100	
	ISO 200	
	ISO 400	
	ISO 800	
	ISO 1600	
	ISO 3200	

- For details on the ISO sensitivity, see page 11.
- You can select only from [ISO AUTO], [ISO 80] to [ISO 400] when set to Burst or Exposure Bracket.
- When shooting under brighter conditions, the camera automatically increases its tone reproduction and helps prevent images to become whitish (excluding when [ISO] is set to [80]).

EV: Adjusting the light intensity

Manually adjusts the exposure.

- When the shooting mode is set to **AUTO**, **SCN** or , [EV] appears in [MENU].



Toward -



Toward +

	-2.0EV	Toward -: Darkens an image.
✓	0EV	The exposure is determined automatically by the camera.
	+2.0EV	Toward +: Brightens an image.

- For details on the Exposure, see page 10.
- The compensation value can be set in 1/3EV increments.
- If a subject is being shot in extremely bright or dark conditions, or the flash is used, the exposure adjustment may not be effective.

Viewing images

▶ (Playback)
button

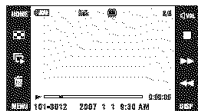
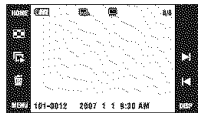
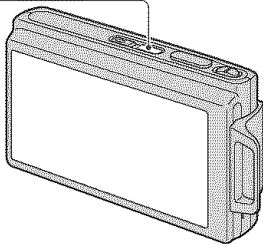

1 Press ▶ (Playback) button.

- If you press ▶ (Playback) when the camera is powered off, the camera is turned on automatically and set to playback mode. To switch to the shooting mode, press ▶ (Playback) again.

2 Touch ◀ (previous)/▶ (next) to select an image.

Movie:

Touch ▶ to play back a movie.

Fast forward/Rewind: ◀◀/▶▶ (Touch ▶ or ■ to return to normal playback.)

Volume control: Touch \llcorner_{vol} , then adjust the volume with \llcorner_{+} / \llcorner_{-} .

Touch \llcorner_{vol} again. The volume control bar disappears.





Stop: Touch ■.

- Movies of image size [320] are displayed in a smaller size.

Viewing an enlarged image (playback zoom)

Touch a still image while it is displayed to enlarge the corresponding area.

Touch  to zoom out.

   : Adjusts the position.

BACK: Cancels playback zoom.

: Turns     on/off.

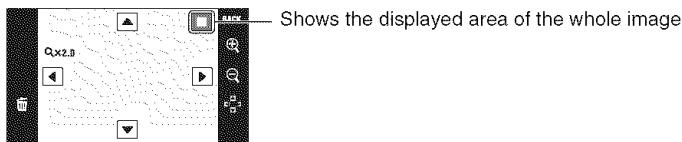

• To store enlarged images: [Trimming] (page 58)

You can also enlarge the image with the zoom (W/T) lever.





Viewing an index screen

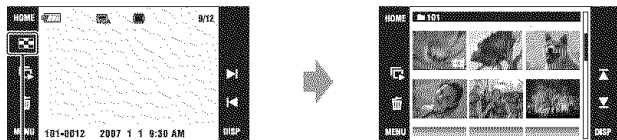

Touch  (Index) to display the index screen.

Touch  /  to display the previous/next page. To return to the single image screen, touch the thumbnail image.



 (Index)

When using the “Memory Stick Duo,” if there are a number of folders, touch  (Select Folder), then select the desired folder from select folder screen.

- You can also access the index screen by selecting  Image Index] in  (View Images) on the HOME screen.
- If you touch [DISP] in index mode, you can set the number of images displayed in the index screen.

Deleting images

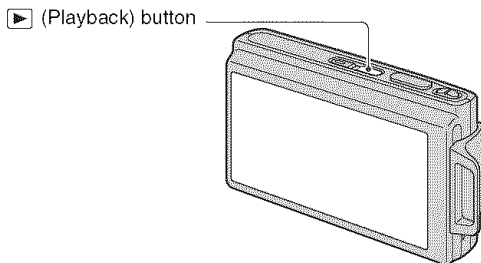



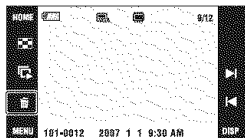

1 Press ▶ (Playback) button.

2 Display the image you want to delete, then touch .



3 Touch [OK].

When you delete images from the MENU screen

- ① Touch [MENU] while displaying in single-image mode or in index mode.
- ② Touch .
- ③ Touch to select the desired deletion method among  (This Image),  (Multiple Images), or  (All In This Folder).

When you select [This Image]

Deletes the selected image.

Touch [OK].

When you select [Multiple Images]

Selects and deletes multiple images at once.

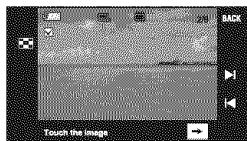

- ① Touch the center of the image to put a check mark on the image you want to delete.
✓ mark is checked in the check box of the image.
To cancel the deletion, touch the image again to deselect the mark.

Single Image

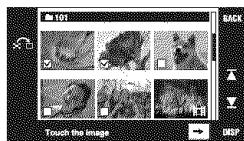

Index Display



- Touching  displays the index screen. At this screen, touch the thumbnail images to add a check mark to the images you want to delete.
 - Touching  at the index screen returns to single-image mode.
- ② Touch [→], and then touch [OK].

When you select [All In This Folder]

Deletes all the images in the selected folder.

Touch [OK].

Learning the various functions – HOME/Menu

Using the HOME screen

The HOME screen is the gateway screen for all the functions of your camera. You can access this screen regardless of whether the camera is in shooting mode or playback mode.

1 Touch [HOME] to display the HOME screen.

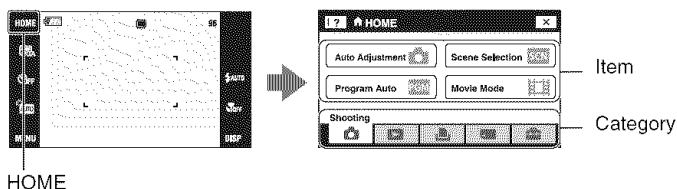





2 Touch the category you want to set.

3 Touch the item in the category you want to set.

- You cannot display the HOME screen when a PictBridge connection or a USB connection is made.
- The camera is set to the shooting mode by pressing the shutter button halfway down.
- Touch [X] or [BACK] to return to the previous screen.

HOME items

Touching [HOME] displays the following items. Details on the items are displayed on the screen by the guide.

Category	Items
 Shooting	Auto Adjustment (page 43) Scene Selection (page 43) Program Auto (page 43) Movie Mode (page 43)
 View Images	Single Image (page 54) Image Index (page 54) Slideshow (page 54)
 Printing, Other	Print (page 102) Music Tool (page 97) Download Music Format Music
 Manage Memory	Memory Tool Memory Stick Tool (page 68) Format Create REC. Folder Change REC. Folder Copy Internal Memory Tool (page 70) Format
 Settings	Main Settings Main Settings 1 (page 71) Beep Function Guide Initialize Calibration Housing Main Settings 2 (page 73) USB Connect COMPONENT Video Out TV TYPE
	Shooting Settings Shooting Settings 1 (page 75) AF Illuminator Grid Line AF Mode Digital Zoom Shooting Settings 2 (page 78) Auto Orientation Auto Review Smile Level
	Clock Settings (page 79)
	Language Setting (page 80)

Using the menu items

1 Touch [MENU] to display the menu.

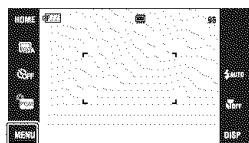

MENU

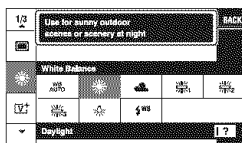

Touch [?] to hide this guide (page 22).

- Different items will become visible depending on the selected mode.

2 Touch the desired menu item.

- If the desired item is hidden, keep touching ▲/▼ until the item appears on the screen.

3 Touch the desired setting item.

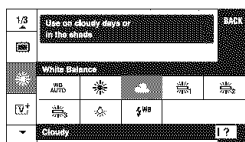

4 Touch [BACK] to turn off the menu.

Menu items

The available menu items vary depending on the mode setting (shooting/viewing) and shooting mode.

Only the available items are displayed on the screen.

(✓ : available)

Selected mode:	Auto Adjustment	Scene Selection	Program Auto	Movie Mode
----------------	-----------------	-----------------	--------------	------------

Menu for shooting (page 43)

REC Mode	✓	✓ ^{*2}	✓	—
EV ^{*1}	✓	✓	—	✓
Focus ^{*1}	—	—	—	✓
Metering Mode ^{*1}	—	—	—	✓
White Balance	—	✓ ^{*2}	✓	✓
Color Mode	—	—	✓	✓
Flash Level	—	—	✓	—
Red Eye Reduction	✓	✓ ^{*2}	✓	—
Face Detection	✓	✓ ^{*2}	—	—
SteadyShot	—	✓	✓	✓
Setup	✓	✓	✓	✓

^{*1} You can also change this setting in [Program Auto] (page 30).

^{*2} The operation is limited according to the selected Scene Selection mode (page 44).

Menu for viewing (page 57)

 (Retouch)

 (Multi Resizing)

 (Slideshow)

 (Protect)

 (Print)

 (Select Folder)

 (Paint)

 (Wide Zoom Display)

 (Delete)

DPOF

 (Rotate)

 (Volume Settings)



Switching the shooting mode

You can switch the shooting mode on the HOME screen.

Shooting modes:

There are three shooting modes available for still images: Auto Adjustment, Scene Selection, Program Auto; and there is one recording mode for movies. The default setting is Auto Adjustment.

To switch the shooting mode to other than Auto Adjustment, follow the procedure described below.

- ① Touch [HOME] to display HOME screen.
- ② Touch (Shooting).
- ③ Touch the desired mode.

- You can also change the shooting mode by touching the shooting mode setting icon (page 17).

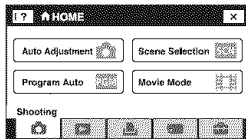

AUTO: Auto Adjustment

Allows you to shoot still images with the setting adjusted automatically.

SCN: Scene Selection

Allows you to shoot with preset settings according to the scene (page 44).

PGM: Program Auto

Allows you to shoot with the exposure adjusted automatically (both the shutter speed and the aperture value). Also you can select various settings using the menu. (For details on the functions available, see page 42.)

MOV: Movie Mode

Allows you to record movies with audio.

Shooting images using Scene Selection

Scene Selection modes

The following modes are predetermined to match the scene conditions.



ISO High Sensitivity

Allows you to shoot images without a flash under low light conditions, reducing blur.



Landscape

Focuses only on a distant subject to shoot landscapes, etc.



Hi-Speed Shutter

Allows you to capture fast moving subjects outdoors or in other bright places.

- The shutter speed becomes faster, so images shot in dark places become darker.

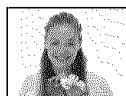

Smile Shutter

When the camera detects a smile, the shutter is released automatically. For details, see page 46.



Soft Snap

Allows you to shoot images with a softer atmosphere for portraits of people, flowers, etc.



Beach

When shooting seaside or lake side scenes, the blue of the water is clearly recorded.



Snow

When shooting snowy scenes or other places where the whole screen appears white, use this mode to prevent sunken colors and record clear images.



Twilight Portrait*

Suitable for shooting portraits in dark places. Allows you to shoot sharp images of people in dark places without losing the dark atmosphere of the surroundings.





Fireworks*

Allows you to record fireworks in all their splendor.



Twilight*























Allows you to shoot night scenes at far distance without losing the dark atmosphere of the surroundings.

*When you shoot images using  (Twilight Portrait),  (Twilight) or  (Fireworks) mode, the shutter speed is slower and the images tend to blur. To prevent blurring, the use of a tripod is recommended.

Functions you can use in Scene Selection

For shooting an image appropriately according to the scene condition, a combination of functions is determined by the camera. Some functions are not available, depending on the Scene Selection mode.

(✓: you can select the desired setting)

	Macro/ Close Focus	Flash	Face Detection	Burst/ Bracket	EV	White Balance	Red Eye Reduction	SteadyShot
	✓/—		—	—	✓	✓*	—	✓
	✓/—	✓	—	—	✓	—	—	✓
	✓/—	✓	✓	✓	✓	—	✓	✓
	✓/—		—	—	✓	—	✓	✓
	—/—		—	—	✓	—	—	✓
	—/—	 / 	—	✓	✓	—	✓	✓
	✓/—	 / 	—	✓	✓	—	✓	✓
	✓/—	 / 	—	✓	✓	—	✓	✓
	✓/—	 / 	—	✓	✓	—	✓	✓
	—/—		—	—	✓	—	—	✓

* [Flash] of white balance cannot be selected.

Shooting in Smile Shutter mode

① Press the shutter button all the way down.

The [😊] is displayed to indicate that the camera is at the capturing smile screen. When a smile is detected, the shutter is released automatically to take the picture.

The smile shutter lamp will light when shooting (pages 15, 16).

② Holding down the shutter button again exits the capturing smile screen.

- A maximum of 6 images can be taken. Shooting ends automatically when either the recording medium/internal memory becomes full or 6 images is reached.
- If a smile is not detected, set the [Smile Level] (page 78).
- A smile cannot be detected unless a face is detected.
- In some shooting environments, face detection is not possible and the shutter will not be released.
- A smile can be detected for only one person displayed in the face detection frame after pressing the shutter button all the way down.
- If multiple faces are detected, the face touched before pressing the shutter button halfway down is given priority. If no face is touched, the camera will select the primary subject for deciding which face is given priority.
- The image may not be in focus if the distance between the camera and the subject is changed after pressing the shutter button all the way down. The suitable exposure may not be obtained if the surrounding brightness changes.
- The shutter may be released at the wrong time.

💡 Hints for better capturing of smiles



- ① Do not cover the eyes with the bangs.
- ② Try to orient the face in front of the camera and be as level as possible. The detection rate is higher when the eyes are narrowed.
- ③ Give a clear smile with an open mouth. The smile is easier to detect when the teeth are showing.

The available modes are indicated as shown below. For details on how to operate the menu, see page 41.

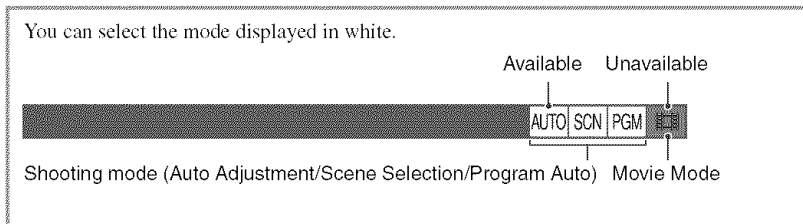







The default settings are marked with .

REC Mode: Selecting the continuous shooting method

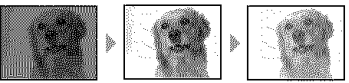

Selects whether the camera performs continuous shooting or not when you press the shutter button.

	 (Normal)	Does not shoot continuously.
	 (Burst)	<p>Records up to 100 images in succession when you press and hold down the shutter button.</p>  <ul style="list-style-type: none"> The flash is set to  (Flash Off).
	BRK ±0.3EV	<p>Records a series of three images with the exposure values automatically shifted (Exposure Bracket). The larger the bracket step value, the larger the shift of the exposure value.</p> <ul style="list-style-type: none"> When you cannot decide the correct exposure, shoot in the Exposure Bracket mode, shifting the exposure value. You can select the image with the best exposure afterward.  <ul style="list-style-type: none"> You cannot shoot in the Exposure Bracket mode, when the shooting mode is set to AUTO (Auto Adjustment). The flash is set to  (Flash Off).
	BRK ±0.7EV	
	BRK ±1.0EV	

On the Burst

- When recording with the self timer, a series of a maximum of five images is recorded.
- The recording interval is approx. 0.46 seconds (DSC-T200)/approx. 0.51 seconds (DSC-T70/T75). The recording interval becomes longer, depending on the setting for the image size.
- When the battery level is low, or when the internal memory or “Memory Stick Duo” is full, the Burst stops.
- You may not be able to shoot images in the Burst mode depending on the Scene Selection mode (page 45).

On the Exposure Bracket

- The focus and white balance are adjusted for the first image, and these settings are also used for the other images.
- When the exposure is manually adjusted (page 34), the exposure is shifted based on the adjusted brightness.
- The recording interval is approx. 0.46 seconds (DSC-T200)/approx. 0.51 seconds (DSC-T70/T75).
- If the subject is too bright or too dark, you may be unable to shoot properly with the selected bracket step value.
- You may not be able to shoot images in the Exposure Bracket mode depending on the Scene Selection mode (page 45).

EV: Adjusting the light intensity



Manually adjusts the exposure. This menu is the same as the menu that appears when you touch the EV setting icon in  mode. See page 34.

Focus: Changing the focus method



You can change the focus method. Use the menu when it is difficult to get the proper focus in auto focus mode. This menu is the same as the menu that appears when you touch the Focus setting icon in  mode. See page 31.

Metering Mode: Selecting the metering mode









Selects the metering mode that sets which part of the subject to measure to determine the exposure. This menu is the same as the menu that appears when you touch the Metering Mode setting icon in  mode. See page 33.



White Balance: Adjusting the color tones





Adjusts the color tones according to the lighting condition in a situation, for example, when the colors of an image look strange.

✓	WB AUTO (Auto)	Adjusts the White Balance automatically.
	☀ (Daylight)	Adjusts for outdoors conditions on a fine day, evening views, night scenes, neon signs, fireworks, etc. 
	☁ (Cloudy)	Adjusts for a cloudy sky or a shady location. 
	 (Fluorescent Light 1)/  (Fluorescent Light 2)/  (Fluorescent Light 3)	Fluorescent Light 1: Adjusts for white fluorescent lighting. Fluorescent Light 2: Adjusts for natural white fluorescent lighting. Fluorescent Light 3: Adjusts for day white fluorescent lighting. 
	💡 (Incandescent)	Adjusts for places under incandescent lamp, or under bright lighting, such as in a photo studio. 





	 WB (Flash) (Only for still image)	Adjusts for the flash conditions. • You cannot select this item when shooting movies. 
--	--	---

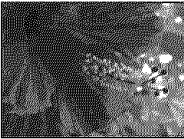

- For details on the white balance, see page 11.
- Under fluorescent lights that flicker, the white balance function may not work correctly even though you select [Fluorescent Light 1], [Fluorescent Light 2], [Fluorescent Light 3].
- Except in [Flash] modes, [White Balance] is set to [Auto] when the flash strobes.
- Some options are not available depending on the Scene Selection mode (page 45).

Color Mode: Changing the vividness of the image or adding special effects

 AUTO SCN PGM 

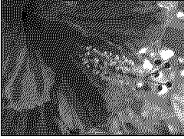
You can change the brightness of the image, accompanied by effects.

<input checked="" type="checkbox"/>	<input type="checkbox"/>  (Normal)	Sets the image to normal color hue. 
	<input type="checkbox"/>  (Vivid)	Sets the image to bright and deep color. 
	<input type="checkbox"/>  (Natural)	Sets the image to quiet color. 

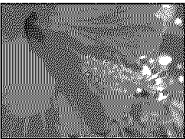
	 (Sepia)	Sets the image to sepia color. 
	 (B & W)	Sets the image to monochromatic color. 



- You can select only [Normal], [Sepia] or [B & W] when shooting movies.

Flash Level: Adjusting the amount of flash light







Adjusts the amount of flash light.

	 (-)	Toward -: Makes the flash level lower.
✓	 (Normal)	
	 (+)	Toward +: Makes the flash level higher.

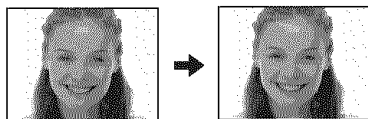

- To change flash mode, see page 29.

Red Eye Reduction: Reducing the red-eye phenomenon



The flash strobos two or more times before shooting to reduce the red-eye phenomenon when using the flash.

<input checked="" type="checkbox"/>	 (Auto)	When the Face Detect function is activated, the flash strobos automatically to reduce the red-eye phenomenon.
	 (On)	The flash always strobos to reduce the red-eye phenomenon.
	 (Off)	Does not use Red Eye Reduction.



- Because it takes about a second until the shutter clicks, hold the camera firmly to prevent the effects of vibration. Also, do not let the subject move.
- Red-eye reduction may not produce the desired effects depending on individual differences, the distance to the subject, if the subject does not see the pre-strobe, or other conditions. In such a case, you can correct the red-eye phenomenon using [Retouch] in the viewing menu after shooting (page 58).
- If you do not use the Face Detect function, Red Eye Reduction does not work, even when you select [Auto].
- This setting is not available depending on the Scene Selection mode (page 45).





Face Detection: Detecting the face of subject





Selects whether to use the Face Detect function continuously or when the touch panel is touched.



	 (Continuous)	<p>Detecting the faces of your subject will also adjust focus, strobe, exposure, white balance, and pre-strobe for red-eye reduction.</p>  <p>Touching the face changes the Face Detection frame to the Face Priority frame. If the subject area you touch is not a face, the section near the touched area is brought into focus.</p>
<input checked="" type="checkbox"/>	 (When touched)	Touch the screen, and if a face is detected, operation is the same as [Continuous].

- When the Face Detect function is activated
 - You cannot use the AF illuminator.
 - You cannot use the Digital Zoom function.
- In  (Soft Snap) mode, the default setting is [Continuous].
- In the  (Smile Shutter) mode, the Face Detect function activates continuously.
- The camera can detect up to 8 subject faces. However, in  (Soft Snap) mode, it can detect only up to 4 subject faces.
- When the camera detects more than one subject, the camera will judge which is the main subject and set focus by priority.
- The frame which the focus is set will turn green by pressing the shutter button half way down. Even when the frame does not turn green, if the distance of the subject which the focus is set on and other subjects are the same, the focus is set on all subjects.
- Face Detection may fail, depending on the conditions under which it is used.
- When the shooting mode is a mode other than **AUTO** (Auto Adjustment),  (Smile Shutter), and  (Soft Snap) mode, the Face Detect function is always off.

SteadyShot: Selecting the anti-blur mode





Selects the anti-blur mode.

<input checked="" type="checkbox"/>	 (Shooting)	Activates the anti-blur function when pressing the shutter button halfway down.
<input type="checkbox"/>	 (Continuous)	Always activates the anti-blur function. You can stabilize images even when zooming up a far subject. <ul style="list-style-type: none"> • Battery consumption is faster than in [Shooting] mode.
<input type="checkbox"/>	 (Off)	Does not use anti-blur mode.

- In Auto Adjustment mode, [SteadyShot] will be set to [Shooting].
- For movies, the options are limited to [Continuous] and [Off]. The default setting is set to [Continuous].
- The anti-blur function may not work properly in the following cases.
 - When camera shake is too strong
 - When the shutter speed is slow, for example, shooting night scenes

Setup: Selecting the shooting settings



Selects the settings for the shooting function. These items appearing in this menu are same ones as those in  [Shooting Settings] in  (Settings) on the HOME screen. See page 40.



Playing back images from the HOME screen

You can select the ways to play back images.

- ① Touch [HOME].
- ② Touch (View Images).
- ③ Touch the desired viewing method.

(Single Image): Playing back a single image

Displays the image shot last.

This is the same as pressing the (Playback) (page 35).

(Image Index): Playing back a list of images

Displays a list of images contained in the selected folder.

This is the same as touching the (Index) (page 36).

(Slideshow): Playing back a series of images

- ① Touch [Slideshow] on the HOME screen.

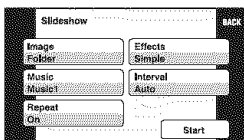

- ② Touch [Start] to start playback.

To adjust the volume of the music

Touch the panel to display the volume control screen, then adjust the volume with \uparrow/\downarrow . Or adjust from the (Volume Settings) on the MENU screen, before the playback starts.



- Touch [X] to turn off the volume control screen.

To end the slide show

Touch the panel, and then touch [Exit].

To change the setup

You can change the slide show settings.

- ① Touch [MENU] →  (Slideshow) →  (Slide show).
 - ② Touch the desired menu item.
 - ③ Touch the desired setting, then touch [Start].
- You can change the settings by touching  on the volume control screen.

The following items can be set.





The default settings are marked with .

Image		
Selectable only when a "Memory Stick Duo" (not supplied) is inserted into the camera.		
	Folder	Plays back all the images in the selected folder.
	All	Plays back all the images in a "Memory Stick Duo" in order.

Effects		
	Simple	A simple slide show suitable for a wide range of scenes.
	Nostalgic	A moody slide show reproducing the atmosphere of a movie scene.
	Stylish	A stylish slide show proceeding at a middle tempo.
	Active	A high-tempo slide show suitable for active scenes.
	Normal	A basic slide show switching images at a predetermined interval.

- Only still images are displayed when [Simple], [Nostalgic], [Stylish] or [Active] is selected.
- Music is not played (set to [Off]) during a [Normal] slide show. The sound of movies will be heard.



Music		
The preset-Music differs depending on the effect you select.		
The background music and effect combination can be changed.		
	Music1	The default setting for a [Simple] slide show.
	Music2	The default setting for a [Nostalgic] slide show.
	Music3	The default setting for a [Stylish] slide show.
	Music4	The default setting for a [Active] slide show.
	Off	Setting for a [Normal] slide show. No Music available.

Playing back images from the HOME screen

Interval		
<input type="checkbox"/>	3 sec	Sets the display interval of images for a [Normal] slide show.
<input type="checkbox"/>	5 sec	
<input type="checkbox"/>	10 sec	
<input type="checkbox"/>	30 sec	
<input type="checkbox"/>	1 min	
<input checked="" type="checkbox"/>	Auto	The interval is set to suit the selected [Effects] item. The setting is fixed to [Auto] when [Normal] is not selected as the [Effects].

Repeat		
<input checked="" type="checkbox"/>	On	Plays back images in a continuous loop.
<input type="checkbox"/>	Off	After all the images have been played back, the slide show ends.

To add/change Music files

You can transfer a desired music file from your CDs or MP3 files to the camera to play back during Slide show. You can transfer music using [ Music Tool] in [ (Printing, Other) on the HOME screen and the "Music Transfer" software (supplied) installed on a computer. For details, see pages 97 and 99.

- You can record up to four pieces of music on the camera (The four preset pieces (Music1 – Music4) can be replaced with the ones you transferred).
- A maximum length of each music file for music playback of the camera is about 3 minutes.
- If you cannot playback a Music file due to damage or other malfunctions to the file, execute [Format Music] (page 97) and transfer the music again.

This section explains the menu items available when you touch [MENU] in playback mode. For details on how to use the menu, see page 41.



(Retouch): Retouching still images





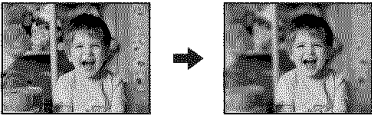

Allows you to modify or apply special effects to a still image. The original image is retained.

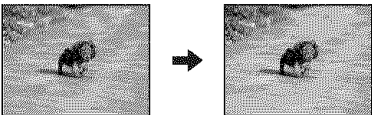

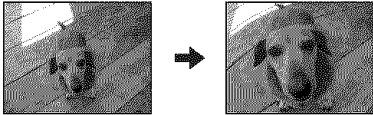
To retouch the still images

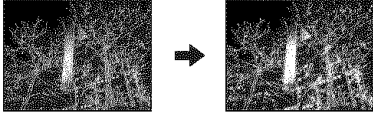
- ① Select the images you want to retouch from the single -image screen or the index screen.
- ② Touch [MENU].
- ③ Touch  (Retouch), then touch the desired mode.
- ④ Retouch the images according to the instructions.

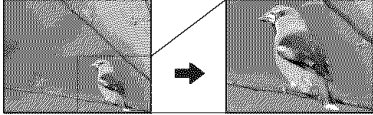
- Touching **OK** in the Retouch screen enables checking of the effects that are currently set (except for [Trimming] and [Red Eye Correction]).
- Images cannot be retouched while the camera is connected to a TV.

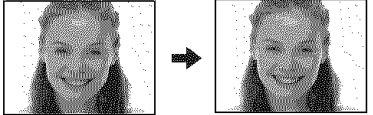
 (Soft Focus)	<p>Blurs the periphery around a chosen point to signalize a subject.</p>  <ol style="list-style-type: none"> ① Touch the center point of the desired image to retouch, then touch [→]. ② Adjust the desired range to retouch with ◀/▶, then touch [→]. ③ Select level of retouch with ◀/▶, then touch [→]. ④ Touch [Save].
 (Partial Color)	<p>Surrounds a chosen point in monochrome to signalize a subject.</p>  <ol style="list-style-type: none"> ① Touch the center point of the desired image to retouch, then touch [→]. ② Adjust the desired range to retouch with ◀/▶, then touch [→]. ③ Touch [Save].

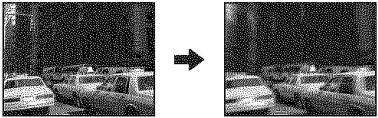
 (Fisheye Lens)	<p>Applies a fisheye effect around a chosen point.</p>  <ol style="list-style-type: none"> ① Touch the center point of the desired image to retouch, then touch [→]. ② Select level of retouch with ◀▶, then touch [→]. ③ Touch [Save].
 (Cross Filter)	<p>Adds starburst effects to light sources.</p>  <ol style="list-style-type: none"> ① Adjust the desired length to retouch with ◀▶, then touch [→]. ② Select level of retouch with ◀▶, then touch [→]. ③ Touch [Save].
 (Trimming)	<p>Records the zoomed playback image.</p>  <ol style="list-style-type: none"> ① Touch the image or slide the W/T lever to zoom in on the trimming range. ② Set the point with ▲▼/◀▶, then touch [→]. ③ Select image size with ◀▶, then touch [→]. ④ Touch [Save]. <ul style="list-style-type: none"> • The quality of trimmed images may deteriorate. • The image size that you can trim may vary depending on the image.
 (Red Eye Correction)	<p>Corrects the red-eye phenomenon caused by flash.</p>  <p>After red eye correction is completed, touch [Save].</p> <ul style="list-style-type: none"> • You may not be able to correct the red-eye phenomenon depending on the image.

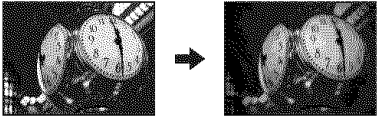
 (Radial Blur)	<p>Decides the center point for expressing movement in the still image.</p>  <ol style="list-style-type: none"> ① Touch the center point of the desired image to retouch, then touch [→]. ② Adjust the desired range to retouch with ◀/▶, then touch [→]. ③ Touch [Save].
 (Retro)	<p>This softens the image by blurring the focus and lowering the surrounding light so that it appears as if it was taken by an old camera.</p>  <ol style="list-style-type: none"> ① Adjust the desired range to retouch with ◀/▶, then touch [→]. ② Select the level of retouch with ◀/▶, then touch [→]. ③ Touch [Save].



 (Paint): Painting on still images



Paints characters or graphics on the still images, then saves them as new image.
See page 65.

 **(Multi Resizing): Changing the image size according to usage**

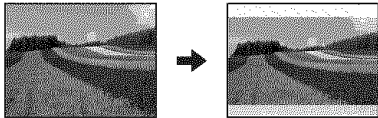
You can change the aspect ratio and size of the shooting images.

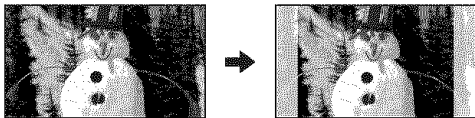
You can convert images to the 16:9 aspect ratio for high definition viewing and to the VGA size for blog or e-mail attachments.



HDTV ()	4:3/3:2 to 16:9 
Blog/E-mail ()	16:9/3:2 to 4:3 

- ① Display the desired image to be changed.
- ② Touch [MENU], and then touch .
- ③ Touch the desired size of the image ( (HDTV) or  (Blog/E-mail)).
- ④ Specify the area you want to trim and touch [→]. ([Trimming] → page 58)
- ⑤ Touch [Save].

The resized image is saved as a newest image in the REC folder.

- For details about the image size, see page 12.
- You cannot resize movies.
- You cannot resize the images from VGA to  (HDTV).
- Enlarging the image and trimming can reduce the image quality.

 **(Wide Zoom Display): Displaying still images in 16:9**

During playback, still images at a 4:3 and 3:2 aspect ratio are played at a 16:9 aspect ratio. Touch [MENU] →  (Wide Zoom Display) →  (Wide Zoom Display).



- Turning off the power or switching to shooting mode cancels this setting.
- The only images that can be played in Wide Zoom are 4:3 and 3:2 images. Movies, 16:9 images, and portrait images cannot be zoomed.
- Touching the center of the touch panel changes to the wide zoom exit screen.

 (Slideshow): Playing back a series of images

Touch [MENU] →  (Slideshow) →  (Slideshow).

This item has same function as [ Slideshow] on the HOME screen.

See page 54.



To play back a slide show from the index screen

Touch  and then touch the image from which you want to start the slide show.

 (Delete): Deleting images

Selects and deletes images on the single-image screen or the index screen.





See page 37.

 (This Image)	Deletes the image that is now selected.
 (Multiple Images)	Selects and deletes multiple images.
 (All In This Folder)	Deletes all the images in the selected folder.





 (Protect): Preventing accidental erasure

Protects images against accidental erasure.

The  (Protect) indicator appears on the protected image.



 (This Image)	Protects/unlocks the currently selected image.
 (Multiple Images)	Selects and protects/unlocks multiple images.
 (Select All in This Folder)	Protects all the images in the selected folder.
 (Clear All in This Folder)	Unlocks all the images in the selected folder.

To protect an image

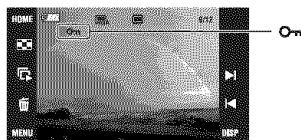



- ① Display the image you want to protect.
- ② Touch [MENU] to display the menu.
- ③ Display  (Protect) by touching /, then touch it.
- ④ Touch  (This Image).





To select and protect images

- ① Touch [MENU] in single-image mode or in index mode.
- ② Display  (Protect) by touching , then touch it.
- ③ Touch  (Multiple Images).



In single-image mode:

- ④ Use  to display the image to be protected, and then touch the center of that image.
 is attached to the selected image.
- ⑤ Touch  to display other images you want to protect, then touch the center of that image.
- ⑥ Touch  → [OK].

In index mode:

- ④ Touch the thumbnail image you want to protect.
 is attached to the selected image.
 - ⑤ To protect other images, repeat step ③.
 - ⑥ Touch  → [OK].
- Touch  on the index screen to return to the single-image screen.

To select all the images in the folder

- ① Touch [MENU] in index mode.
- ② Display  (Protect) by touching , then touch it.
- ③ Touch  (Select All in This Folder).
 All the images in the selected folder are protected.

- Protection cannot be set when there are more than 100 files in a folder. In this case, set the protection from  (Multiple Images).

To cancel the protection





Select the image for which you want to cancel protection, and unlock it by performing the same procedure to protect it.

 (Protect) indicator disappears.

- Touch  (Clear All in This Folder) to unlock all the images in the folder.
- Note that the formatting erases all the data stored on the recording media, even if the images are protected, and these images cannot be restored.
- It may take some time to protect an image.

DPOF: Adding a Print order mark

Adds **DPOF** (Print order) mark to images you want to print.
See page 105.



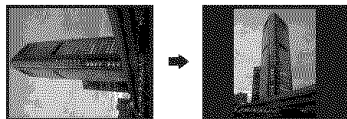

 (This Image)	Attaches/clears the DPOF-based print marks to (from) the image that is now selected.
 (Multiple Images)	Selects images and attaches/clears the DPOF-based print marks to (from) the images.
 (Select All in This Folder)	Attaches the DPOF-based print marks to all the images in the selected folder.
 (Clear All in This Folder)	Clears the DPOF-based print marks from all the images in the selected folder.

 (Print): Printing images using a printer

Prints the recorded images.
See page 102.

 (Rotate): Rotating a still image

Rotates a still image.

- ① Display the image to be rotated.
- ② Touch [MENU] to display the menu.
- ③ Display  (Rotate) by touching ▲/▼, then touch it.
- ④ Touch  (Rotate).
- ⑤ Touch [ ] to rotate the image.
- ⑥ Touch [OK].

- You cannot rotate protected images or movies.
- You may not be able to rotate images shot with other cameras.
- When viewing images on a computer, the image rotation information may not be reflected depending on the software.

(Select Folder): Selecting the folder for viewing images

Selects the folder containing the image you want to playback when using the camera with “Memory Stick Duo”.

- ① Select the desired folder with ▲/▼.

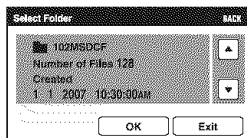

- ② Touch [OK].

To cancel selecting the folder selection

Touch [Exit] or [BACK] in step ②.

On the folder

The camera stores images in a specified folder of a “Memory Stick Duo”. You can change the folder or create a new one.

- To create a new folder → [Create REC.Folder] (page 68).
- To change the folder for recording images → [Change REC.Folder] (page 69).
- When multiple folders are created in the “Memory Stick Duo” and the first or last image in the folder is displayed, the following indicators appear.

 Moves to the previous folder

 Moves to the next folder

 Moves to either the previous or next folders

(Volume Settings): Adjusting the volume

Adjusts the volume.

See page 35.

Painting or putting stamps on still images (Paint)

You can paint or put stamps on still images and save them separately. Use the paint pen (supplied) for this operation.

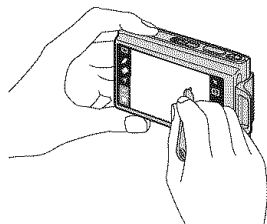

- You cannot paint or put stamps on movies.
- When viewing recorded images on a TV, you cannot paint the images.

To display the painting

- 1 Press (Playback) button.
- 2 Touch [MENU] → (Paint) → (Paint).

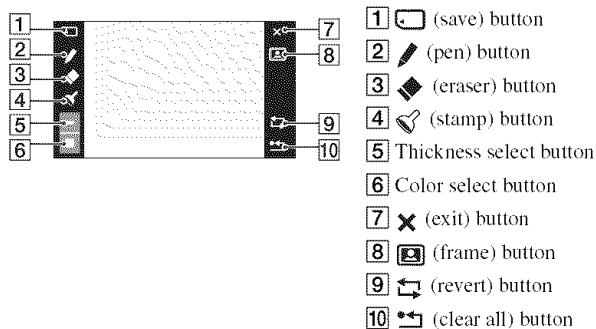

To paint characters or graphics

- 1 Touch .
- 2 Select the line thickness.
Touch the thickness select button, the desired thickness, then [BACK].
- 3 Paint characters or graphics.

To stamp

- 1 Touch .
- 2 Select a stamp.
Touch the stamp select button, the desired stamp, then [BACK].
- 3 Put stamps on the image.

Painting or putting stamps on still images (Paint)

To add a frame



- ① Touch .
- ② Select a frame.
Select the desired frame with ◀▶, then touch [OK].

Touch [BACK] to return to the painting screen.

To change the color of the line

Touch the color select button, a desired color, then [BACK].

To make corrections

Touch , then rub the part you want to erase using the paint pen. Otherwise, touch  to revert to the previous state (if you touch  again, it returns to the latest state).

- You can select the thickness of the eraser in the same way as you do for the pen, using the thickness select button. The selected thickness is applied to both the line and eraser.

Erasing all painting

- ① Touch .
“Clear All” appears.
- ② Touch [OK].
All painting will disappear from the image.

Touch [Cancel] to cancel the operation.

To save the painting

- ① Touch .
- ② Touch the image size to be saved, then touch [OK].
The painted image is recorded in the recording folder as the newest file.

Touch [Cancel] to cancel the operation.

- You can select the image size to be saved from [VGA] or [3M].

To exit paint mode

- ① Touch .
“Exit” appears.
- ② Touch [OK].

Touch [Cancel] to cancel the operation.

Customizing the Manage Memory feature and the Settings

You can change the default settings using  (Manage Memory) or  (Settings) on the HOME screen.

1 Touch [HOME] to display the HOME screen.

HOME

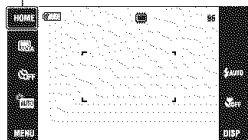

2 Touch (Manage Memory) or .

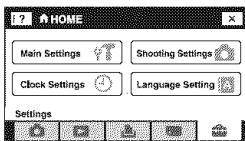

3 Touch the desired setting item.

Touch  to display the other setting items.

4 Touch the setting item that you want to change, and then touch the desired setting value to set it.

To cancel the setting change

Touch [Cancel] if it is one of the setting item.
If not, touch [BACK] or [X].

- This setting is maintained even when the power is turned off.

Memory Tool — Memory Stick Tool

This item appears only when a “Memory Stick Duo” is inserted in the camera.

Format

Formats the “Memory Stick Duo”. A commercially available “Memory Stick Duo” is already formatted, and can be used immediately.

- Note that formatting irrevocably erases all data on a “Memory Stick Duo”, including even protected images.

- ① Touch [Format].
The message “All data on Memory Stick will be erased” appears.
- ② Touch [OK].
The format is completed.

To cancel the formatting

Touch [Cancel] or [BACK] in step ②.

Create REC.Folder

Creates a folder in a “Memory Stick Duo” for recording images.

- ① Touch [Create REC.Folder].
The message “Creating REC.folder” appears.

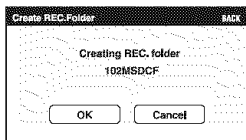

- ② Touch [OK].
A new folder is created with a number incremented one higher than the largest number, and the folder becomes the current recording folder.

To cancel the folder creation

Touch [Cancel] or [BACK] in step ②.

- When not creating a new folder, the “101MSDCF” folder is selected as the recording folder.
- You can create folders designated up to “999MSDCF”.
- You cannot delete a folder with the camera. To delete a folder, use your computer, etc.
- Images are recorded in the newly created folder until a different folder is created or selected.
- Up to 4,000 images can be stored in one folder. When the folder capacity is exceeded, a new folder is automatically created.
- For details, see “Image file storage destinations and file names” (page 92).

Change REC.Folder

Changes the folder currently used for recording images.

- ① Touch [Change REC.Folder].
The folder selection screen appears.

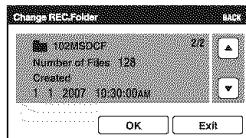

- ② Touch [OK].

To cancel changing the recording folder

Touch [Exit] or [BACK] in step ②.

- You cannot select the “100MSDCF” folder as a recording folder.
- You cannot move recorded images to a different folder.

Copy

Copies all images in the internal memory to a “Memory Stick Duo”.

- ① Insert a “Memory Stick Duo” with sufficient capacity.
- ② Touch [Copy].
The message “All data in internal memory will be copied” appears.
- ③ Touch [OK].
Copying starts.

To cancel the copying

Touch [Cancel] or [BACK] in step ③.

- Use a fully charged battery pack. If you attempt to copy image files using a battery pack with little remaining charge, the battery pack may run out, causing copying to fail or possibly corrupting the data.
- You cannot copy individual images.
- The original images in the internal memory are retained even after copying. To delete the contents of the internal memory, remove the “Memory Stick Duo” after copying, then execute the [Format] command in [Internal Memory Tool] (page 70).
- When you copy data from the internal memory to the “Memory Stick Duo,” a new folder will be created in the “Memory Stick Duo.” You cannot choose a specific folder on the “Memory Stick Duo” as the destination for the data to be copied.
- Even if you copy data, a **DPOF** (Print order) mark is not copied.

Memory Tool — Internal Memory Tool

This item does not appear when a “Memory Stick Duo” is inserted in the camera.

Format

Formats the internal memory.

- Note that formatting irrevocably erases all data in the internal memory, including even protected images.

- ① Touch [Format].
The message “All data in internal memory will be erased” appears.
- ② Touch [OK].
The format is completed.

To cancel the formatting

Touch [Cancel] or [BACK] in step ②.

Main Settings — Main Settings 1

The default settings are marked with .

Beep

Selects the sound produced when you operate the camera.

	Shutter	Turns on the shutter sound when you press the shutter button.
	On	Turns on the beep/shutter sound when you operate the touch panel/press the shutter button.
	Off	Turns off the beep/shutter sound.

Function Guide

When you operate the camera, the description of functions is displayed.

	On	Displays the function guide.
	Off	Does not display the function guide.

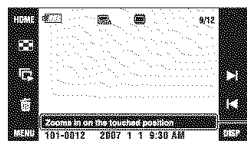

The display of this guide can be turned on and off with the above setting.

- The guide that is displayed by touching [?] cannot be turned on or off with the above setting. To turn off this guide, touch [?] again (page 22).

Initialize

Initializes the setting to the default setting. Even if you execute this function, the images stored in the internal memory are retained.

- ① Touch [Initialize].
The message “Initialize all settings” appears.
- ② Touch [OK].
The settings are reset to the default setting.

To cancel the resetting

Touch [Cancel] or [BACK] in step ②.

- Make sure that the power is not disconnected during resetting.

Calibration

Enables you to perform calibration when the touch panel buttons do not react at the appropriate points where you touch.

Using the paint pen, touch the × mark displayed on the screen.

To stop the calibration process mid-way, touch [Cancel]. The adjustments made up to that point are not effected.

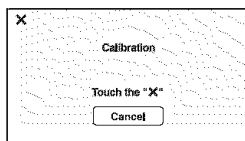

The × mark moves on the screen.

If you fail to press the right spot, the calibration is not performed. Press the × mark again.

Housing

Changes the function of some buttons to operate the camera installed in the Marine Pack.

<input type="checkbox"/>	On ()	Changes the function of the buttons.
<input checked="" type="checkbox"/>	Off	Does not change any functions.

The buttons will work as follows when the setting is [On].

- Objects cannot be brought into focus by touching the screen.
- When [Spot AF] is selected, operation brings the center section into focus.
- During playback, playback zoom operation cannot be performed.
- During playback, sliding the zoom (W/T) lever moves screen playback forward or backward.
- The screen display is always [Normal].
- Some functions are limited. (The icons are not displayed.)
- For details, see the operating instructions supplied with the Marine Pack.

Main Settings — Main Settings 2

The default settings are marked with .

USB Connect

Selects the USB mode to be used when connecting the camera to a computer or a PictBridge compliant printer using the cable for multi-use terminal.

	PictBridge	Connects the camera to a PictBridge compliant printer (page 102). When you connect the camera to a computer, the copy wizard starts automatically, and the images in the recording folder on the camera are copied to the computer. (with Windows XP/Vista, Mac OS X)
	Mass Storage	Establishes a Mass Storage connection between the camera and a computer or other USB device (page 90).
	Auto	The camera recognizes automatically and sets up communication with a computer or PictBridge compliant printer (pages 90 and 102). <ul style="list-style-type: none"> • If the camera and a PictBridge compliant printer cannot be connected when set to [Auto], change the setting to [PictBridge]. • If the camera and a computer or other USB device cannot be connected when set to [Auto], change the setting to [Mass Storage].

COMPONENT

Selects the video signal output type from SD and HD(1080i), according to the TV connected (page 81).

	HD(1080i)	Selects this item to connect the camera to a 1080i-capable High Definition TV.
	SD	Selects this item to connect the camera to a TV that is not compatible with an HD(1080i) signal.

Video Out

Sets the video signal output according to the TV color system of the connected video equipment. Different countries and regions use different TV color systems. If you want to view images on a TV screen, check page 84 for the TV color system of the country or region where the camera is used.

NTSC	Sets the video output signal to NTSC mode (e.g., for the USA, Japan).
PAL	Sets the video output signal to PAL mode (e.g., for Europe).

TV TYPE

Set to the aspect ratio of television to be connected for playback.

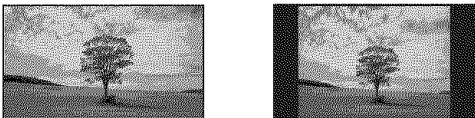
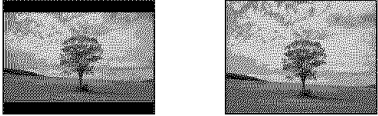
<input checked="" type="checkbox"/>	16:9	<p>Selects this item to play back the images on a wide screen television.</p> <p>16:9 image 4:3 image</p> 
	4:3	<p>Selects this item to play back the images on a 4:3 ratio television.</p> <p>16:9 image 4:3 image</p> 





Shooting Settings — Shooting Settings 1

The default settings are marked with .

AF Illuminator

The AF illuminator supplies fill light to focus more easily on a subject in dark surroundings. The AF illuminator emits red light allowing the camera to focus easily when the shutter button is pressed halfway, until the focus is locked. The  indicator appears at this time.

	Auto	Uses the AF illuminator.
	Off	Does not use AF illuminator.

- If the AF illuminator light does not reach the subject sufficiently or the subject has no contrast, focus will not be achieved.
(The recommended distance
DSC-T200: up to approx. 2.5 m (8 feet 2 1/2 inches) (zoom: W)/up to approx. 2.0 m (6 feet 6 3/4 inches) (zoom: T)
DSC-T70/T75: up to approx. 2.7 m (8 feet 10 3/8 inches) (zoom: W)/up to approx. 2.5 m (8 feet 2 1/2 inches) (zoom: T))
- Focus is achieved as long as the AF illuminator light reaches the subject, regardless of whether light fails to reach the center of the subject.
- You cannot use the AF illuminator when:
 - When Focus preset is set (page 31).
 - When  (Smile Shutter) mode or  (Twilight) mode or  (Landscape) mode or  (Fireworks) mode is selected in the Scene Selection mode.
 - When the Face Detect function is activated.
 - When [Housing] is set to [On].
- When you use AF illuminator, the normal AF range finder frame is disabled and a new AF range finder frame is displayed by a dotted line. AF operates with priority on subjects located near the center of the frame.
- The AF illuminator emits very bright light. Although there are no problems with safety, do not look directly into the AF illuminator emitter at close range.

Grid Line

With reference to the grid lines, you can easily set a subject in a horizontal/vertical position.

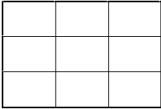
<input type="checkbox"/>	On	Displays the grid lines. 
<input checked="" type="checkbox"/>	Off	Does not display the grid lines.

- The grid lines are not recorded.

AF Mode

Selects the auto focus operation mode.

<input checked="" type="checkbox"/>	Single	Automatically adjusts the focus when the shutter button is pressed and held halfway down. This mode is useful for shooting stationary subjects.
<input type="checkbox"/>	Monitor	Automatically adjusts the focus before the shutter button is pressed and held halfway down. This mode shortens the time needed for focusing. <ul style="list-style-type: none"> • Battery consumption is faster than in [Single] mode.

- When the Face Detect function is activated, the AF mode is disabled.

Digital Zoom

Selects the digital zoom mode. The camera enlarges the image using optical zoom (DSC-T200: up to 5×/DSC-T70/T75: up to 3×). When the zoom scale is exceeded, the camera uses either smart or precision digital zoom.

<input checked="" type="checkbox"/>	Smart (Smart zoom) (sQ)	Enlarges the image digitally within the range where the image will not be distorted, according to the image size. This is not available when the image size is set to [8M] or [3:2]. <ul style="list-style-type: none"> • The maximum zoom scale of Smart zoom is shown in the following table.
<input type="checkbox"/>	Precision (Precision digital zoom) (PQ)	Enlarges all image sizes up to a maximum of 10× (DSC-T200)/6× (DSC-T70/T75), but the image quality deteriorates.
<input type="checkbox"/>	Off	Does not use the digital zoom.

Image size and maximum zoom scale using Smart zoom

Size	Maximum zoom scale	
	DSC-T200	DSC-T70/T75
5M	Approx. 6.3×	Approx. 3.8×
3M	Approx. 8×	Approx. 4.8×
VGA	Approx. 25×	Approx. 15×
16:9	Approx. 8.5×	Approx. 5.1×

- When the Face Detect function is activated, you cannot use the Digital Zoom.

Shooting Settings — Shooting Settings 2

The default settings are marked with .

Auto Orientation

When the camera is rotated to shoot a portrait image, the camera records its position change and displays the image in the portrait position.

<input checked="" type="checkbox"/>	On	Records the image with the correct orientation.
<input type="checkbox"/>	Off	Auto Orientation deactivated.

- Depending on the shooting angle of the camera, the orientation of the image may not be recorded correctly. When the orientation of the image is not correct, you can rotate the image using the procedure on page 63.

Auto Review

Displays the recorded image on the screen for approximately two seconds immediately after shooting a still image.

<input checked="" type="checkbox"/>	On	Use the Auto Review.
<input type="checkbox"/>	Off	Does not use Auto Review.

- If you press the shutter button halfway down during this period, the recorded image display disappears and you can immediately shoot the next image.

Smile Level

This sets the smile detection level when [Smile Shutter] (page 44) is selected in the Scene Selection.



<input type="checkbox"/>	High	Setting to [High] makes it easier to detect a smile.
<input checked="" type="checkbox"/>	Medium	
<input type="checkbox"/>	Low	

- It is difficult to detect the smile under the following conditions.
 - When the face is too dark or too bright
 - When the face is far from the camera and too small
 - When the subject is wearing sunglasses or glasses with thick frames
 - When the front hair, hat, or other objects are covering the eyes
 - When the subject is not facing towards the front

④ Clock Settings

Clock Settings

Sets the date and time.

- ① Select  (Clock Settings) from  (Settings) on the HOME screen.
- ② Touch [Clock Settings].
- ③ Touch the desired date display format, then touch [→].
The clock settings screen appears.

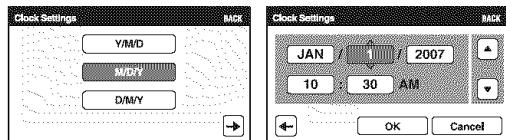

- ④ Touch each item, then set its numeric value by touching ▲/▼.
- ⑤ Touch [OK].

To cancel the clock setting

Touch [Cancel] or [BACK] in step ⑤.

A Language Setting

Language Setting

Selects the language to be used to display the menu items, warnings, and messages.



Viewing images on a TV

You can view images on a TV screen by connecting the camera to a TV. The connection varies according to the type of TV the camera is connected to. See “TV TYPE” (page 74).

- Icons and other indicators do not appear on the TV screen.

Viewing images by connecting your camera to a TV with the supplied cable for multi-use terminal

Turn off both your camera and the TV before connecting the camera and the TV.

1 Connect the camera to the TV.

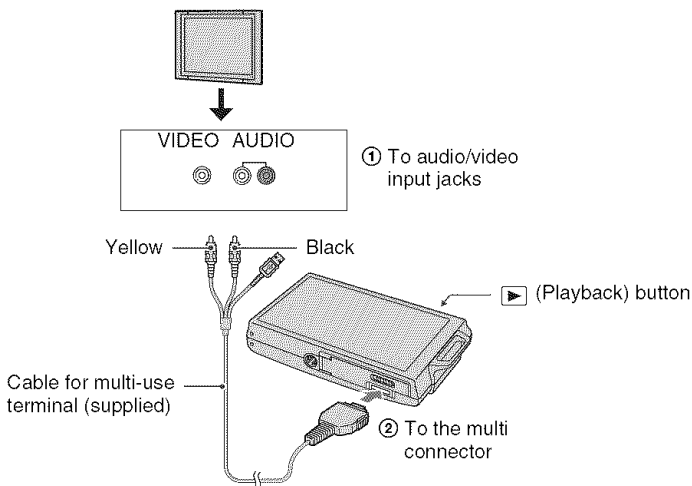

- If your TV has stereo input jacks, connect the audio plug (black) of the cable for multi-use terminal to the left audio jack (white).

2 Turn on the TV and switch the input.

- For details, see the operating instructions supplied with the TV.

3 Press (Playback) button to turn on the camera.

Images shot with the camera appear on the TV screen.

Touch  on the control button to select the desired image.

- When using your camera abroad, it may be necessary to switch the video signal output to match that of your TV system (page 74).

Viewing an image by connecting your camera to a HD TV

You can view an image recorded on the camera by connecting the camera to an HD (High Definition) TV* with the HD Output Adaptor Cable (DSC-T75 only).

Turn off both your camera and the TV before connecting the camera and the TV.

* Images taken at [VGA] resolution cannot be played back with high image quality.

- In [Wide Zoom Display], still images with an aspect of 4:3 or 3:2 can be displayed with an aspect of 16:9 (page 60).
- In [Multi Resizing], the aspect can be converted to 16:9 for high definition viewing (page 60).

1 Connect the camera to an HD (High Definition) TV with a HD Output Adaptor Cable (DSC-T75 only).

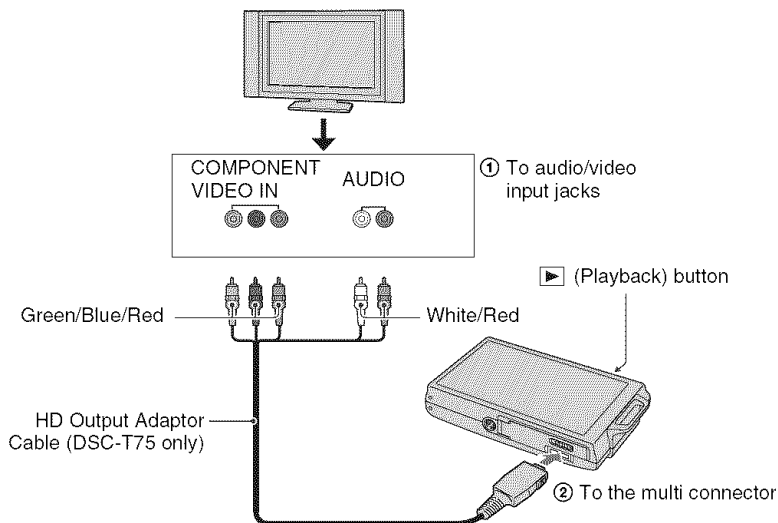

2 Turn on the TV and switch the input.

- For details, see the operating instructions supplied with the TV.

3 Press (Playback) button to turn on the camera.

Images shot with the camera appear on the TV screen.

Touch   to select the desired image.

- Set [COMPONENT] to [HD(1080i)] in [Main Settings 2] by selecting  (Settings) on the HOME screen (page 73).
- When using your camera abroad, it may be necessary to switch the video signal output to match that of your TV system (page 74).
- You cannot view movies output in HD signal format.

On TV color systems

If you want to view images on a TV screen, you need a TV with a video input jack and the cable for multi-use terminal. The color system of the TV must match that of your digital still camera. Check the following lists for the TV color system of the country or region where the camera is used.

NTSC system

Bahama Islands, Bolivia, Canada, Central America, Chile, Colombia, Ecuador, Jamaica, Japan, Korea, Mexico, Peru, Surinam, Taiwan, the Philippines, the U.S.A., Venezuela, etc.

PAL system

Australia, Austria, Belgium, China, Czech Republic, Denmark, Finland, Germany, Holland, Hong Kong, Hungary, Italy, Kuwait, Malaysia, New Zealand, Norway, Poland, Portugal, Singapore, Slovak Republic, Spain, Sweden, Switzerland, Thailand, United Kingdom, etc.

PAL-M system

Brazil

PAL-N system

Argentina, Paraguay, Uruguay

SECAM system

Bulgaria, France, Guiana, Iran, Iraq, Monaco, Russia, Ukraine, etc.



Enjoying your Windows computer

For details on using a Macintosh computer, refer to “Using your Macintosh computer” (page 98). Illustrations of screens used in this section are based on the English version.

- Under Windows Vista, some names and operations may differ from those described below.



Install the software (supplied) first (page 87)



- Installing the software as follows:
 - “Picture Motion Browser”
 - “Music Transfer”

Copying images to your computer (page 90)



- Copying images to your computer using “Picture Motion Browser”.
- Enjoying images using “Picture Motion Browser” and “Music Transfer” as follows:
 - Viewing images saved on your computer
 - Editing images
 - Displaying the shooting locations of still images on maps online
 - Creating a disc with the images shot (requires CD or DVD disc writing drive)
 - Printing or saving still images with the date
 - Adding/changing Music for slide show (using “Music Transfer”)

Additional information on this product and answers to frequently asked questions can be found at the Sony Customer Support Website.
<http://www.sony.net/>

Recommended computer environment

The following environment is recommended for a computer connected to the camera.

Recommended environment for copying images

OS (pre-installed): Microsoft Windows 2000 Professional SP4, Windows XP* SP2/Windows Vista*

- Operation is not assured in an environment based on an upgrade of the operating systems described above or in a multi-boot environment.

USB jack: Provided as standard

Recommended environment for using “Picture Motion Browser” and “Music Transfer”

OS (pre-installed): Microsoft Windows 2000 Professional SP4, Windows XP* SP2/Windows Vista*

CPU/Memory: Pentium III 500 MHz or faster, 256 MB of RAM or more (Recommended: Pentium III 800 MHz or faster and 512 MB of RAM or more)

Hard Disk: Disk space required for installation—approximately 200 MB

Display: Screen resolution: 1024 × 768 dots or more
Colors: High Color (16-bit color) or more

* 64-bit editions and Starter (Edition) are not supported.

Notes on connecting the camera to a computer

- Operations are not guaranteed for all the recommended computer environments mentioned above.
- If you connect two or more USB devices to a single computer at the same time, some devices, including the camera, may not operate, depending on the types of USB devices you are using.
- Operations are not guaranteed when using a USB hub.
- Connecting the camera using a USB interface that is compatible with Hi-Speed USB (USB 2.0 compliant) allows advanced transfer (high speed transfer) as the camera is compatible with Hi-Speed USB (USB 2.0 compliant).
- There are three modes for a USB connection when connecting a computer, [Auto] (default setting), [Mass Storage] and [PictBridge] modes. This section describes the [Auto] and [Mass Storage] as examples. For details on [PictBridge], see page 73.
- When your computer resumes from a suspend or sleep mode, communication between the camera and your computer may not recover at the same time.

Installing the software (supplied)



You can install the software (supplied) using the following procedure.

- Log on as Administrator.

1 Turn on your computer, and insert the CD-ROM (supplied) into the CD-ROM drive.

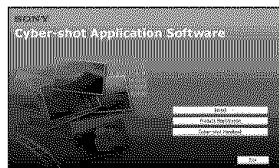
The installation menu screen appears.



- If it does not appear, double-click  (My Computer) →  (SONYPICUTIL).
- Under Windows Vista, the AutoPlay screen may appear. Select “Run Install.exe.” and follow the instructions that appear on the screen to proceed with the installation.

2 Click [Install].

The “Choose Setup Language” screen appears.

3 Select the desired language, then click [Next].

The [Location Settings] screen appears.

4 Select the [Region] and [Country/Area], then click [Next].

When the [Welcome to the InstallShield Wizard for SonyPicture Utility] appears, click [Next].

The “License Agreement” screen appears. Read the agreement carefully. If you accept the terms of the agreement, click the radio button next to [I accept the terms of the license agreement] and then click [Next].

5 Follow the instructions on the screen to complete the installation.

- When the restarting confirmation message appears, restart the computer following the instructions on the screen.
- DirectX may be installed depending on the system environment of your computer.

6 Remove the CD-ROM after the installation is complete.

- Installing software as follows:
 - Picture Motion Browser
 - Music Transfer

After you install the software, a shortcut icon for the customers registration website is created on the desktop.

Once you register on the website, you can get secure and useful customer support.
<http://www.sony.net/registration/di>

Installing the software (supplied)

After you install the software, the short cut icons for “Picture Motion Browser”, “Picture Motion Browser Guide”, “Music Transfer” are created on the desktop.



- Double-click to start “Picture Motion Browser”.



- Double-click to start “Picture Motion Browser Guide”.



- Double-click to start “Music Transfer”.

On the “Picture Motion Browser” (supplied)

You can use still images and movies from the camera more than ever by taking advantage of the software.

This section summarizes the “Picture Motion Browser”.

“Picture Motion Browser” overview

With the “Picture Motion Browser” you can:

- Import images shot with the camera and display them on the computer.
- Organize images on the computer on a calendar by shooting date to view them.
- Retouch (Red Eye Correction, etc.), print, and send still images as e-mail attachments, change the shooting date and more.
- Still images can be printed or saved with the date.
- You can create a data disc using a CD burner drive or DVD burner drive.
- For details, refer to “Picture Motion Browser Guide”.

To access “Picture Motion Browser Guide” from the Start menu, click [Start] → [All Programs] (in Windows 2000, [Programs]) → [Sony Picture Utility] → [Help] → [Picture Motion Browser Guide].

Starting and exiting the “Picture Motion Browser”

Starting the “Picture Motion Browser”

Double-click the  (Picture Motion Browser) icon on the desktop.

Or, from the Start menu: Click [Start] → [All Programs] (in Windows 2000, [Programs]) → [Sony Picture Utility] → [Picture Motion Browser].

- The confirmation message of the Information tool appears on the screen when starting the “Picture Motion Browser” for the first time. Select [Start]. This function informs you of news, such as software updates. You can change the setting later.

Exiting the “Picture Motion Browser”

Click  button in the top right corner of the screen.

Copying images to your computer using the “Picture Motion Browser”

Preparing the camera and the computer

1 Insert a “Memory Stick Duo” with recorded images into the camera.

- When copying images in the internal memory, this step is unnecessary.

2 Insert the sufficiently charged battery pack in the camera, or connect the camera to a wall outlet (wall socket) with the AC Adaptor (not supplied).

- When you copy images to your computer using a battery pack with little remaining charge, copying may fail or image data may become corrupted if the battery pack shuts down too soon.

3 Press  (Playback), then turn on the computer.

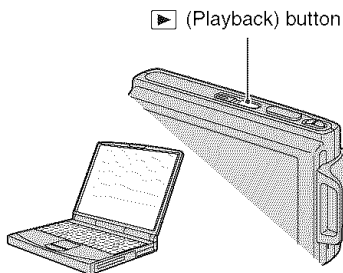

Connecting the camera to your computer

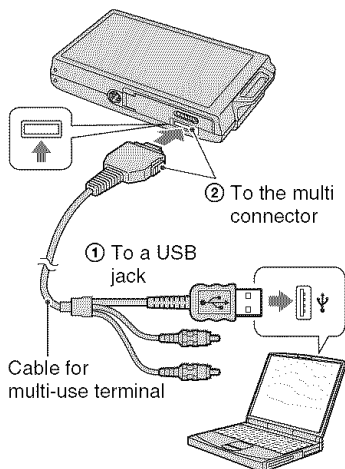

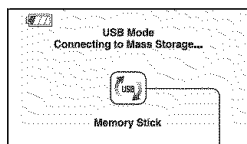

“Connecting to Mass Storage...” appears on the screen of the camera.



Access indicators*

When a USB connection is established for the first time, your computer automatically runs a program to recognize the camera. Wait for a while.

*  is displayed on the screen during the communication session.

Do not operate the computer while the indicator is displayed. When the indicator changes to , you can start using the computer again.

- If “Connecting to Mass Storage...” does not appear, set [USB Connect] to [Mass Storage] (page 73).

Copying images to a computer

1 Connects the camera to a computer as described “Connecting the camera to your computer”.

After making a USB connection, the [Import Media Files] screen of “Picture Motion Browser” appears automatically.

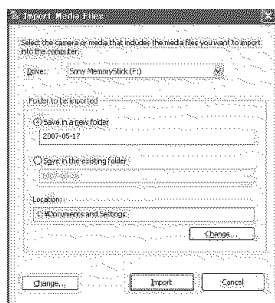

- If you use the Memory Stick slot, refer to page 94.
- In Windows XP/Vista, if the AutoPlay Wizard appears, close it.

2 Import the images.

To start importing images, click the [Import] button.



By default, images are imported into a folder created in “My Pictures” that is named with the date of importing.

- For details on the “Picture Motion Browser”, refer to “Picture Motion Browser Guide”.

Viewing images on your computer

When importing is complete, the “Picture Motion Browser” starts. Thumbnails of the imported images are displayed.

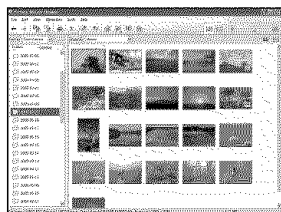

- The “My Pictures” folder is set as the default folder in “Viewed folders”.

Organize images on the computer on a calendar by shooting date to view them. For details, see the “Picture Motion Browser Guide”.

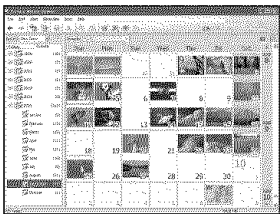

Example: Month display screen

To delete the USB connection

Perform the procedures from step ① to ④ below before:

- Disconnecting the cable for multi-use terminal.
- Removing a “Memory Stick Duo”.
- Inserting a “Memory Stick Duo” into the camera after copying images from the internal memory.
- Turning off the camera.

① Double-click  on the taskbar.



Double-click here

② Click  (USB Mass Storage Device) → [Stop].

③ Confirm the device on the confirmation window, then click [OK].

④ Click [OK].

The device is disconnected.

- Step ④ is unnecessary for Windows XP/ Vista.

Image file storage destinations and file names

The image files recorded with the camera are grouped as folders on the “Memory Stick Duo” or the internal memory.

Example: viewing folders on Windows XP

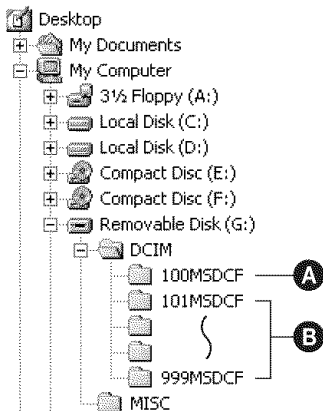

A Folder containing image data recorded using a camera not equipped with the folder creating function

B Folder containing image data recorded using the camera
When no new folders are created, there are folders as follows:

- “Memory Stick Duo”: “101MSDCF” only
- Internal memory: “101_SONY” only
- You cannot record any images to the “100MSDCF” folder. The images in this folder are available only for viewing.
- You cannot record/playback any images to the “MISC” folder.

- Image files are named as follows:
 - Still image files: DSC0□□□□.JPG
 - Movie files: MOV0□□□□.MPG
 - Index image files that are recorded when you record movies: MOV0□□□□.THM□□□□ stands for any number within the range from 0001 to 9999. The numerical portions of the name of a movie file recorded in movie mode and its corresponding index image file are the same.
- For more information about folders, see pages 64 and 68.

Copying images to a computer without “Picture Motion Browser”

You can copy images to your computer without “Picture Motion Browser” as follows.

For a computer with a Memory Stick slot

Remove the “Memory Stick Duo” from the camera and insert it in the Memory Stick Duo Adaptor. Insert the Memory Stick Duo Adaptor in the computer and copy the images.

- Even when you are using Windows 95/98/98 SecondEdition/NT/Me, you can copy images by inserting the “Memory Stick Duo” into the Memory Stick slot on your computer.
- If the “Memory Stick PRO Duo” is not recognized, see page 112.

For a computer without a Memory Stick slot

Make a USB connection and follow the steps below to copy the images to the computer.

- The screen displays shown in this section are the examples for copying images from “Memory Stick Duo”.
- The camera is not compatible with Windows 95/98/98 SecondEdition/NT/Me of the Windows operating system.
When you use a computer without a Memory Stick slot, use a commercially available Memory Stick Reader/Writer to copy images from a “Memory Stick Duo” to your computer.
- To copy images in the internal memory to your computer, copy the images to a “Memory Stick Duo” first, then copy them to your computer.

Copying images to a computer – Windows XP/Vista

This section describes an example of copying images to “My Documents” (For Windows Vista: “Documents”).

1 Prepare the camera and a computer.

Perform the same procedure as described in “Preparing the camera and the computer” on page 90.

2 Connect the camera to your computer with the cable for multi-use terminal.

Perform the same procedure as described in “Connecting the camera to your computer” on page 90.

- If “Picture Motion Browser” is already installed, then [Import Media Files] is started on “Picture Motion Browser” but select [Cancel] to finish.

- 3** Click [Open folder to view files] → [OK] (Only for Windows XP) as the wizard screen appears automatically on the desktop.

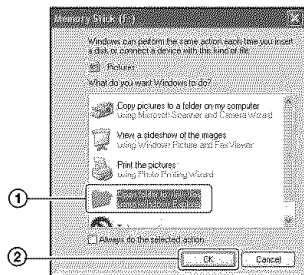

- When the wizard screen does not appear automatically, follow the procedure: → “For Windows 2000” on page 95.

- 4** Double-click [DCIM].

- 5** Double-click the folder where the image files you want to copy are stored. Then, right-click an image file to display the menu and click [Copy].

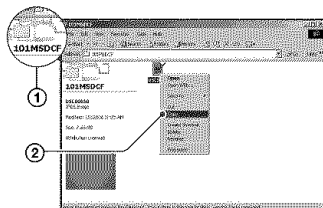

- On the storage destination of the image files, see page 92.

- 6** Double-click the [My Documents] (For Windows Vista: “Documents”) folder. Then, right-click on the “My Documents” window to display the menu and click [Paste].

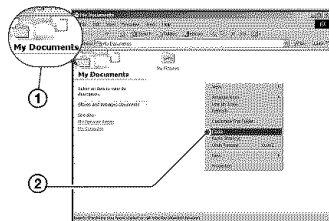

The image files are copied to the “My Documents” (For Windows Vista: “Documents”) folder.

- When an image with the same file name exists in the copy destination folder, the overwrite confirmation message appears. When you overwrite an existing image with a new one, the original file data is deleted. To copy an image file to the computer without overwriting, change the file name and then copy the image file. However, note that if you change the file name (page 96), you may not play back that image with your camera.

For Windows 2000

Double-click [My Computer] → [Removable Disk] after connecting the camera to your computer. Then, perform from step 4.

Viewing image files stored on a computer with the camera copying to the “Memory Stick Duo”

This section describes the process using a Windows computer as an example. When an image file copied to a computer no longer remains on a “Memory Stick Duo”, you can view that image again on the camera by copying the image file on the computer to a “Memory Stick Duo”.

- Skip step 1 if the file name set with your camera has not been changed.
- You may be unable to play back some images depending on the image size.
- Sony does not guarantee playback of image files on the camera if the files have been processed using a computer or recorded with another camera.
- When there are no folders in a “Memory Stick Duo”, create a folder (page 68) with the camera first, then copy the image files.

1 Right-click the image file, then click [Rename]. Change the file name to “DSC0□□□□”.

Enter a number from 0001 to 9999 for □□□□.

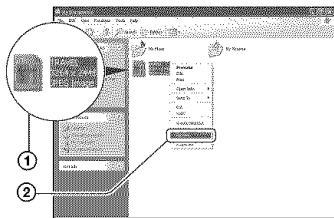

- If the overwrite confirmation message appears, enter a different number.
- An extension may be displayed depending on the computer settings. The extension for still images is JPG, and the extension for movies is MPG. Do not change the extension.

2 Copy the image file to the “Memory Stick Duo” folder in the following order.

- ① Right-click the image file, then click [Copy].
- ② Double-click [Removable Disk] or [Sony MemoryStick] in [My Computer].
- ③ Right-click the [□□□MSDCF] folder in the [DCIM] folder, then click [Paste].
 - □□□ stands for any number within the range from 100 to 999.

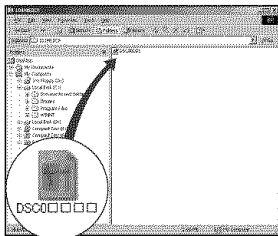

Using the “Music Transfer” (supplied)

You can change the Music files that are preset at the factory to the desired Music files using “Music Transfer” in the CD-ROM (supplied). You can also delete or add these files whenever you want.

Adding/Changing Music using “Music Transfer”

The music formats you can transfer with “Music Transfer” are listed below:

- MP3 files stored on the hard disk drive of your computer
- Music on CDs
- Preset-music saved on this camera

1 Touch [HOME] to display the HOME screen.

2 Touch  (Printing, Other), then touch  Music Tool].

3 Touch [Download Music].
The message “Connect to PC” appears.

4 Make a USB connection between the camera and your computer.

5 Start “Music Transfer”.

6 Follow the instructions on the screen to add/change Music files.

- To restore the music preset at the factory to the camera:

① Perform [Format Music] in step 3.

② Execute [Restore defaults] on “Music Transfer”.

All Music files return to the preset-music, and [Music] in the [Slideshow] menu is set to [Off].

- You can reset the Music files to the preset ones using [Initialize] (page 71), however, other settings will also be reset.
- For details on using “Music Transfer”, see the on-line help in “Music Transfer”.

Using your Macintosh computer

You can copy images to your Macintosh computer.

- “Picture Motion Browser” is not compatible with Macintosh computers.

Recommended computer environment

The following environment is recommended for a computer connected to the camera.

Recommended environment for copying images

OS (pre-installed): Mac OS 9.1/9.2/ Mac OS X (v10.1 to v10.4)

USB jack: Provided as standard

Recommended environment for using “Music Transfer”

OS (pre-installed): Mac OS X (v10.3 to v10.4)

CPU: iMac, eMac, iBook, PowerBook, Power Mac G3/G4/G5 series, Mac mini

Memory: 64 MB or more (128 MB or more is recommended)

Hard Disk: Disk space required for installation—approximately 250 MB

Notes on connecting the camera to a computer

- Operations are not guaranteed for all the recommended computer environments mentioned above.
- If you connect two or more USB devices to a single computer at the same time, some devices, including the camera, may not operate depending on the types of USB devices you are using.
- Operations are not guaranteed when using a USB hub.
- Connecting the camera using a USB interface that is compatible with Hi-Speed USB (USB 2.0 compliant) allows advanced transfer (high speed transfer) as the camera is compatible with Hi-Speed USB (USB 2.0 compliant).

- There are three modes for a USB connection when connecting a computer, [Auto] (default setting), [Mass Storage] and [PictBridge] modes. This section describes the [Auto] and [Mass Storage] as examples. For details on [PictBridge], see page 73.
- When your computer resumes from the suspend or sleep mode, communication between the camera and your computer may not recover at the same time.

Copying and viewing images on a computer

1 Prepare the camera and a Macintosh computer.

Perform the same procedure as described in “Preparing the camera and the computer” on page 90.

2 Connect the camera to your computer with the cable for multi-use terminal.

Perform the same procedure as described in “Connecting the camera to your computer” on page 90.

3 Copy image files to the Macintosh computer.

- ① Double-click the newly recognized icon → [DCIM] → the folder where the images you want to copy are stored.
 - ② Drag and drop the image files to the hard disk icon.
The image files are copied to the hard disk.
- For details on the storage location of the images and file names, see page 92.

4 View images on the computer.

Double-click the hard disk icon → the desired image file in the folder containing the copied files to open that image file.

To delete the USB connection

Drag and drop the drive icon or the icon of the “Memory Stick Duo” to the “Trash” icon beforehand when you perform the procedures listed below, so that the camera is disconnected from the computer.

- Disconnecting the cable for multi-use terminal.
- Removing a “Memory Stick Duo”.
- Inserting a “Memory Stick Duo” into the camera after copying images from the internal memory.
- Turning off the camera.

Adding/Changing Music using “Music Transfer”

You can change the Music files that are preset at the factory to the desired Music files. You can also delete or add these files whenever you want.

The music formats you can transfer with “Music Transfer” are listed below:

- MP3 files stored on the hard disk drive of your computer
- Music on CDs
- Preset-music saved on the camera

To install “Music Transfer”

- Shut down all other application software before you install “Music Transfer”.
- For installation, you need to log on as Administrator.

- ① Turn on your Macintosh computer, and insert the CD-ROM (supplied) into the CD-ROM drive.

- ② Double-click  (SONYPICUTIL).

- ③ Double-click the [MusicTransfer.pkg] file in [Mac] folder.
The installation of the software starts.

To add/change Music files

See “Adding/Changing Music using “Music Transfer”” on page 97.

Technical Support

Additional information on this product and answers to frequently asked questions can be found at the Sony Customer Support Website.
<http://www.sony.net/>

Viewing “Cyber-shot Step-up Guide”

When you install “Cyber-shot Handbook”, “Cyber-shot Step-up Guide” is also installed. “Cyber-shot Step up Guide” further introduces how to use the camera and optional accessories.

Viewing on Windows

Start from the shortcut icon on the desktop.

Viewing on Macintosh

- 1 Copy the [stepupguide] folder in the [stepupguide] folder to your computer.
- 2 Select [stepupguide] → [language] → [GB], and then copy and overwrite all the files from the [GB] folder to the [img] folder in the [stepupguide] folder that was copied to the computer in step 1.
- 3 After copying is complete, double-click “stepupguide.hqx” in the [stepupguide] folder to uncompress it, then double-click the generated file “stepupguide”.

- If an uncompress tool for HQX file is not installed, install the Stuffit Expander.

How to print still images

When you print images shot in [16:9] mode, both edges may be cut off, so be sure to check before printing (page 114).

Printing directly using a PictBridge compliant printer (page 102)

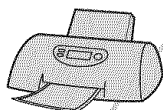

You can print images by connecting the camera directly to a PictBridge compliant printer.

Printing directly using a "Memory Stick" compliant printer

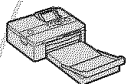

You can print images with a "Memory Stick" compliant printer. For details, see the operating instructions supplied with the printer.

Printing using a computer

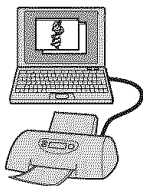

You can copy images to a computer using the supplied "Picture Motion Browser" software and print the images. You can insert the date on the image and print it.

Printing at a shop (page 105)

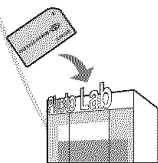

You can take a "Memory Stick Duo" containing images shot with your camera to a photo printing service shop. You can make a **DPOF** (Print order) mark on images which you want to print out in advance.

Printing images directly using a PictBridge compliant printer

Even if you do not have a computer, you can print images shot using your camera by connecting the camera directly to a PictBridge compliant printer.

PictBridge

- “PictBridge” is based on the CIPA standard. (CIPA: Camera & Imaging Products Association)
- You cannot print movies.
- If the  indicator flashes on the screen of the camera (error notification), check the connected printer.

Stage 1: Preparing the camera

Prepare the camera to connect it to the printer with the cable for multi-use terminal. When connecting the camera to a printer that is recognized when [USB Connect] is set to [Auto], Stage 1 is unnecessary.

- It is recommended to use a fully charged battery pack to prevent the power from turning off partway through printing.

1 Touch [HOME] to display the HOME screen.

2 Touch  (Settings), and touch  Main settings].

3 Touch [Main Settings 2] and touch [USB Connect].

4 Touch [PictBridge].

The USB mode is set.

Stage 2: Connecting the camera to the printer

1 Connect the camera to the printer.

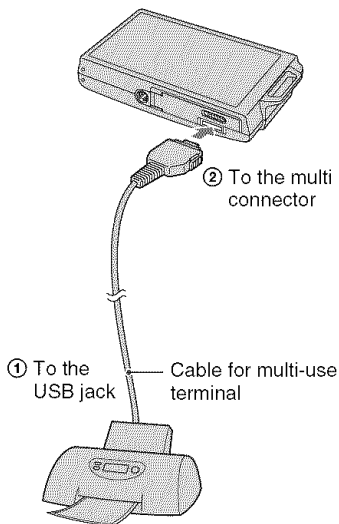





- 2** Press  (Playback) button and turn on your camera and the printer.

After the connection is made, the  indicator appears.



The camera is set to playback mode.

Stage 3: Selecting images you want to print

- 1** Touch [MENU] to display the menu.
- 2** Touch  /  to display  (Print), and touch  (Print).
- A Print menu appears on the screen.
- 3** Touch [This Image] or [Multiple Images].

When you select [This Image]

You can print the selected image. Move on to stage 4.

When you select [Multiple Images]

You can print multiple selected images.

- ① Touch the image you want to print.
✓ mark appears on the selected image.
- ② Touch [→].
- ③ Touch [OK].

Stage 4: Printing

- 1** Touch the desired setting item to make the print settings.

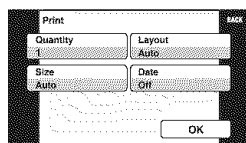

[Quantity]

When the [Layout] is set to [1-up/Borderless] or [1-up/Border]:

Select the number of sheets of an image that you want to print. The image will be printed as a single image.

When the [Layout] is not set to [1-up/Borderless] or [1-up/Border]:

Select the number of sets of images that you want to print as an index image. If you selected [This Image] in stage 3, select the number of the same image you want to print side by side on a sheet as an index image.

- The designated number of images may not all fit onto a single sheet depending on the quantity of images.

[Layout]

Selects the number of images you want to print side by side on a sheet.

[Size]

Select the size of the printing sheet.

[Date]

Select [Day & Time] or [Date] to insert the date and time on images.

- When you choose [Date], the date will be inserted in the order you select (page 79). This function may not be provided depending on the printer.

2 Touch [OK].

The image is printed.

- Do not disconnect the cable for multi-use terminal while the  (PictBridge Connecting) indicator appears on the screen.

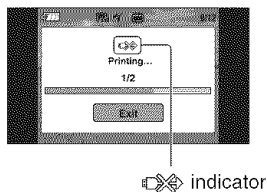

To print other images

Select [Multiple Images], then perform the process again from stage 3.

Stage 5: Completing the printing

Make sure the screen has returned to stage 2, and disconnect the cable for multi-use terminal from the camera.

Printing at a shop

You can take a “Memory Stick Duo” containing images shot with your camera to a photo printing service shop. As long as the shop supports photo printing services conforming to the DPOF, you can make a **DPOF** (Print order) mark on images in advance so that you do not need to reselect them when you print them out at the shop.

- You cannot print images stored in the internal memory at a print shop directly from the camera. Copy the images to a “Memory Stick Duo”, then take the “Memory Stick Duo” to the print shop.

What is DPOF?

DPOF (Digital Print Order Format) is a function allowing you to make a **DPOF** (Print order) mark on images of “Memory Stick Duo” that you want to print out later.

- You can also print the images with the **DPOF** (Print order) mark using a printer that conforms to the DPOF (Digital Print Order Format) standard or using a PictBridge compliant printer.
- You cannot mark movies.

When taking a “Memory Stick Duo” to a shop

- Consult your photo printing service shop as to what types of “Memory Stick Duo” they handle.
- If a “Memory Stick Duo” is not handled by your photo printing service shop, copy the images you want to print out to other medium such as a CD-R and take it to the shop.
- Be sure to take the Memory Stick Duo Adaptor with it.
- Before you take image data to a shop, always copy (back up) your data to a disk.
- You cannot set the number of prints.
- When you want to superimpose dates on images, consult your photo printing service shop.

Marking a selected image

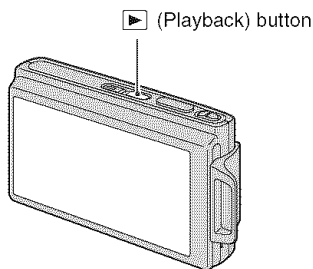

1 Press  (Playback) button.

2 Display the image you want to print.

3 Touch [MENU] to display the menu.

4 Touch [DPOF] and touch  (This Image).

DPOF (Print order) mark is attached to the image.



To remove the mark

Repeat step 3 and 4.

Selecting and marking the images

1 Touch [MENU] while displaying images in single-image mode or in index mode.

2 Touch [DPOF] and touch  (Multiple Images).

3 Touch an image to mark.

✓ mark is attached to the selected image.

Single Image

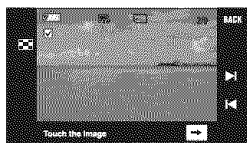

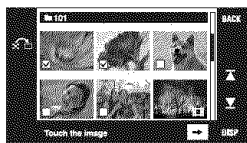

Index Display



4 Touch [→].

5 Touch [OK].

DPOF mark appears on the screen.

- Touching   at the index screen returns to single-image mode.

To remove the mark

Touch the images that you want to remove the marks.

To mark all the images in the folder

- ① Touch [MENU] while displaying images in index mode.
 - ② Touch [DPOF] →  (Select All in This Folder).
 - ✓ mark is attached to all images in the selected folder.
- The print order mark cannot be attached when there are more than 100 files in a folder.

To cancel the selection

To cancel, touch [Exit] in step 5.



Troubleshooting

If you experience trouble with your camera, try the following solutions.

1 Check the items on pages 108 to 116.

If a code such as “C/E:□□:□□” appears on the screen, see page 117.

2 Remove the battery pack, and insert the battery pack again after about one minute, and turn on the power.

3 Initialize the settings (page 71).

4 Consult your Sony dealer or local authorized Sony service facility.

Please understand that you give your consent that the contents of the internal memory, Music files may be checked when you send your camera to be repaired.

Click one of the following items to jump to the page explaining the symptom and cause or the appropriate corrective action.

Battery pack and power	108	Internal memory	114
Shooting still images/movies	108	Printing	114
Viewing images	111	PictBridge compliant printer	115
Deleting images	112	Touch panel	116
Computers	112	Others	116
“Memory Stick Duo”	113		

Battery pack and power

The battery pack cannot be inserted.

- Insert the battery pack correctly by pressing and holding the battery eject lever open.

Cannot turn on the camera.

- After inserting the battery pack into the camera, it may take a little while to get the camera powered.
- Insert the battery pack correctly.
- The battery pack is discharged. Insert a charged battery pack.
- The battery pack is dead (page 123). Replace it with a new one.
- Use a recommended battery pack.

The power turns off suddenly.

- If you do not operate the camera for about three minutes while the power is on, the camera turns off automatically to prevent wearing down the battery pack. Turn on the camera again.
- The battery pack is dead (page 123). Replace it with a new one.

The battery remaining indicator is incorrect.



- This phenomenon occurs when you use the camera in an extremely hot or cold location.
- The displayed battery remaining differs from the current one. Fully discharge and then charge the battery pack to correct the display.
- The battery pack is discharged. Insert a charged battery pack.
- The battery pack is dead (page 123). Replace it with a new one.

The battery cannot be charged while inside the camera.

- Use the battery charger to charge the battery.

Shooting still images/movies

Cannot record images.

- Check the free capacity of the internal memory or “Memory Stick Duo”. If it is full, do one of the following:
 - Delete unnecessary images (page 37).
 - Change the “Memory Stick Duo.”
- You cannot record images while charging the flash.
- When shooting a still image, set the shooting mode other than .
- Set the shooting mode to  when shooting movies.
- The image size is set to [640(Fine)] when recording movies. Do one of the following:
 - Set the image size to other than [640(Fine)].
 - Insert a “Memory Stick PRO Duo.”

This subject is not visible on the screen.

- Your camera is set to the playback mode. Press  to change to the recording mode (page 35).





Anti-blur function does not work.

- The anti-blur function does not work when  appears on the display.
- The anti-blur function may not work properly when shooting night scenes.
- Shoot after pressing the shutter button halfway down; do not press it fully down suddenly.

Recording takes a long time.

- The NR slow shutter function is activated (page 19). This is not a malfunction.









The image is out of focus.

- The subject is too close. Shoot in  (Macro On) recording mode. Make sure to position the lens farther away from the subject than the shortest shooting distance, approximately 8 cm (3 1/4 inches) (W)/80 cm (31 1/2 inches) (T) (DSC-T200), 8 cm (3 1/4 inches) (W)/25 cm (9 7/8 inches) (T) (DSC-T70/T75), when shooting (page 30). Or set to  (Close focus enabled) mode and shoot about 1 to 20 cm (13/32 to 7 7/8 inches) from the W side distance (page 30).
-  (Twilight) mode or  (Landscape) mode or  (Fireworks) mode is selected in the Scene Selection when shooting still images.
- The Focus preset function is selected. Select the auto focus mode (page 31).
- Refer to “How to use the [Spot AF]” on page 32.

Zoom does not work.

- Optical zoom cannot be used in  (Close focus enabled) mode.
- You cannot use the Smart zoom when:
 - the image size is set to [8M], [3:2].
- When the Face Detect function is activated, you cannot use the Digital Zoom.







The flash does not work.

- The flash is set to  (Flash Off) (page 29).
- You cannot use the flash when:
 - [REC Mode] is set to [Burst] or Exposure Bracket (page 47).
 -  (High Sensitivity) mode or  (Twilight) mode or  (Fireworks) mode is selected in the Scene Selection (page 45).
 - Shooting in  (Close focus enabled) mode.
 - Shooting movies.
- Set the flash to  (Flash On) when  (Landscape) mode,  (Beach) mode, or  (Snow) mode is selected in the Scene Selection (page 29).

Fuzzy white circular spots appear in images shot using the flash.

- Particles (dust, pollen, etc.) in the air reflected the flash light and appeared in the image. This is not a malfunction (page 14).
-

The close-up shoot function (Macro) does not work.

-  (Twilight) mode or  (Landscape) mode or  (Fireworks) mode is selected in the Scene Selection (page 45).
 -  (Close focus enabled) mode shooting is disabled when  (Smile Shutter) mode is selected in the Scene Selection.
 - Close-up shooting (macro shooting) is disabled when  (Close focus enabled) mode is selected.
-

The date and time are not displayed on the LCD screen.

- While shooting, the date and time are not displayed. They are displayed only during playback.
-

Cannot insert dates on images.

- This camera does not have a feature for superimposing dates on images (page 114). By using “Picture Motion Browser”, you can print or save images with the date.
-

The F value and shutter speed flash when you press and hold the shutter button halfway down.

- The exposure is incorrect. Correct the exposure (page 34).
-

The screen is too dark or too bright.

- Adjust the brightness of the backlight (page 23).
-

The image is too dark.

- You are shooting a subject with a light source behind the subject. Select the metering mode (page 33) or adjust the exposure (page 34).
-

The image is too bright.

- Adjust the exposure (page 34).
-

The image colors are not correct.

- Set [Color Mode] to [Normal] (page 50).
-

Vertical streaks appear when you are shooting a very bright subject.

- The smear phenomenon is occurring and white, black, red, purple, or other streaks appear on the image. This phenomenon is not a malfunction.

Noise appears in the image when you view the screen in a dark place.

- The camera is attempting to increase the visibility of the screen by temporarily brightening the image under conditions of low illumination. There is no effect on the recorded image.

The eyes of the subject come out red.

- Set [Red Eye Reduction] to [Auto] or [On] (page 52).
- Shoot the subject at a distance closer than the flash range using the flash.
- Light the room and shoot the subject.
- Retouch the image using [Red Eye Correction] (page 58).

Dots appear and remain on the screen.

- This is not a malfunction. These dots are not recorded (page 2).

Cannot shoot images in succession.

- The internal memory or “Memory Stick Duo” is full. Delete unnecessary images (page 37).
- The battery level is low. Insert charged battery pack.

Viewing images

Your camera cannot playback images.

- Press  (Playback) button (page 35).
- The folder/file name has been changed on your computer (page 96).
- When an image file has been processed by a computer or when the image file was recorded using a model other than that of your camera, playback on your camera is not guaranteed.
- The camera is in USB mode. Delete the USB connection (page 92).

The date and time are not displayed.

- [Display Setup] is set to [Simple] or [Image Only]. Touch [DISP] to set [Display Setup] to [Normal] (page 23).

The image appears rough right after playback starts.

- The image may appear rough right after playback starts due to image processing. This is not a malfunction.

The icons no longer appear.

- When the top right of the screen is touched, the icons will momentarily disappear. Taking your finger off the screen will make the icons reappear.
- [Display Setup] is set to [Image Only]. Set to [Normal] or [Simple].

The slideshow music (background music) does not play.

- Use “Music Transfer” to import music into the camera (page 97).
-

The image does not appear on the TV.

- Check [Video Out] to see if the video output signal of your camera is set to the color system of your TV (page 74).
 - Check whether the connection is correct (page 81).
 - If the USB connector of the cable for multi-use terminal is connected to another device, disconnect it (page 92).
 - You are trying to play back movies in HD(1080i) output. Recorded movies cannot be viewed at high-definition image quality. Set [COMPONENT] to [SD] (page 73).
-

Deleting images

Your camera cannot delete an image.

- Cancel the protection (page 61).
-

Computers

Computer OS compatibility with camera is unknown.

- Check “Recommended computer environment” on page 86 for Windows, and page 98 for Macintosh.
-

“Memory Stick PRO Duo” is not recognized by a computer with a “Memory Stick” slot.

- Check that the computer and the Memory Stick Reader/Writer support “Memory Stick PRO Duo”. Users of computers and Memory Stick Readers/Writers made by manufacturers other than Sony should contact those manufacturers.
 - If “Memory Stick PRO Duo” is not supported, connect the camera to the computer (pages 90 and 98). The computer recognizes the “Memory Stick PRO Duo”.
-

Your computer does not recognize your camera.

- Turn on the camera.
- When the battery level is low, insert the charged battery pack or use the AC adaptor (not supplied) (page 90).
- Set [USB Connect] to [Mass Storage] (page 73).
- Use the cable for multi-use terminal (supplied) (page 90).
- Disconnect the cable for multi-use terminal from both the computer and the camera, and connect it again firmly.
- Disconnect all equipment other than the camera, the keyboard and the mouse from the USB connectors of your computer.
- Connect the camera directly to your computer without passing through a USB hub or other device (page 90).

Cannot copy images.

- Connect the camera and your computer correctly making a USB connection (page 90).
- Follow the designated copy procedure for your OS (pages 91 and 98).
- When you shoot images with a “Memory Stick Duo” formatted by a computer, you may not be able to copy the images to a computer. Shoot using a “Memory Stick Duo” formatted by the camera (page 68).

After making a USB connection, “Picture Motion Browser” does not start automatically.

- Make the USB connection after the computer is turned on (page 90).

Cannot play back images on your computer.

- If you are using “Picture Motion Browser”, refer to “Picture Motion Browser Guide” (page 89).
- Consult the computer or software manufacturer.

You do not know how to use “Picture Motion Browser”.

- Refer to “Picture Motion Browser Guide” (page 89).

The image and sound are interrupted by noise when you view a movie on a computer.

- You are playing back the movie directly from the internal memory or the “Memory Stick Duo”. Copy the movie to the hard disk of your computer, then play back the movie from the hard disk (page 90).

Cannot print an image.

- Refer to the operation manual of the printer.

Images once copied to a computer cannot be viewed on the camera.

- Copy them to a folder recognized by the camera, such as “101MSDCF” (page 92).
- Follow the correct procedures (page 96).

“Memory Stick Duo”

Cannot insert a “Memory Stick Duo”.

- Insert it in the correct direction.

You have formatted a “Memory Stick Duo” by mistake.

- All the data on the “Memory Stick Duo” is deleted by formatting. You cannot restore it.

Internal memory

Cannot playback or record images using the internal memory.

- There is a “Memory Stick Duo” inserted in the camera. Remove it.

Cannot copy the data stored in the internal memory to a “Memory Stick Duo”.

- The “Memory Stick Duo” is full. Copy to a “Memory Stick Duo” with sufficient capacity.

Cannot copy the data on the “Memory Stick Duo” or the computer to the internal memory.

- Data on a “Memory Stick Duo” or a computer cannot be copied to the internal memory.

Printing

Also see “PictBridge compliant printer” (as follows) in conjunction with the following items.

Images are printed with both edges cut off.

- Depending on your printer, the left, right, top, and bottom edges of the image may be cut off. Especially when you print an image shot with the image size set to [16:9], the lateral end of the image may be cut off.
- When printing images using your own printer, cancel the trimming or borderless settings. Consult the printer manufacturer as to whether the printer provides these functions or not.
- When having images printed at a digital print shop, ask the shop whether they can print the images without cutting off both edges.

Cannot print images with the date.

- Using “Picture Motion Browser”, you can print images with date.
- This camera does not have a feature for superimposing dates on images. However, because the images shot with the camera include information on the recording date, you can print images with the date superimposed if the printer or the software can recognize Exif information. For compatibility with Exif information, consult the manufacturer of the printer or the software.
- When you print images at a shop, images can be printed with the date if you ask them to do so.

PictBridge compliant printer

A connection cannot be established.

- The camera cannot be connected directly to a printer that is not compliant with the PictBridge standard. Consult the printer manufacturer as to whether the printer is compliant with PictBridge or not.
- Check that the printer is turned on and can be connected to the camera.
- Set [USB Connect] to [PictBridge] (page 73).
- Disconnect and connect the cable for multi-use terminal again. If an error message is indicated on the printer, refer to the operating instructions supplied with the printer.

Cannot print images.

- Check that the camera and the printer are properly connected using the cable for multi-use terminal.
- Turn on the printer. For further information, refer to the operating instructions supplied with the printer.
- If you select [Exit] during printing, images may not be printed. Disconnect and connect the cable for multi-use terminal again. If you still cannot print your images, disconnect the cable for multi-use terminal, turn the printer off and then on, then connect the cable for multi-use terminal again.
- Movies cannot be printed.
- Images shot using cameras other than this camera or images modified with a computer may not be printed.

Printing is canceled.

- Confirm that you have disconnected the cable for multi-use terminal before the  (PictBridge Connecting) mark disappears.

Cannot insert the date or print images in the index mode.

- The printer does not provide these functions. Consult the printer manufacturer as to whether the printer provides these functions or not.
- The date may not be inserted in the index mode depending on the printer. Consult the printer manufacturer.

“---- -- --” is printed on the date-inserted part of the image.

- Images that do not have the recording data cannot be printed with the date inserted. Set [Date] to [Off] and print the image again (page 103).

Cannot select the print size.

- Consult the printer manufacturer as to whether the printer can provide the desired size.

Cannot print the image at the size selected.

- Disconnect the cable for multi-use terminal and reconnect it whenever you change the paper size after the printer has been connected to the camera.
 - The print setting of the camera differs from that of the printer. Change the setting of either the camera (page 103) or the printer.
-

Cannot operate the camera after canceling printing.

- Wait for a while as the printer is carrying out the cancellation. It may take some time depending on the printer.
-

Touch panel

Cannot operate the touch panel buttons correctly or fully.

- Perform [Calibration] (page 72).
 - [Housing] is set to [On] (page 72).
-

The paint pen operation reacts at inappropriate points.

- Perform [Calibration] (page 72).
-

Others

The file number cannot be reset.

- Even if you change the recording media, the file number cannot be reset in the camera. To reset, perform [Format] (pages 68, 70) with the camera, and then reinitialize the settings (page 71). However, all data will be erased, and all settings including the date and time are cancelled.
-

The lens gets fogged.

- Moisture condensation has occurred. Turn off the camera and leave it for about an hour before using it.
-

The camera becomes warm when you use it for a long time.

- This is not a malfunction.
-

The Clock Set screen appears when you turn on the camera.

- Set the date and time again (page 79).
-

You want to change the date or time.

- Set the date and time again (page 79).
-

Warning indicators and messages

Self-diagnosis display

If a code starting with a letter of the alphabet appears, your camera has a self-diagnosis display. The last two digits (indicated by □□) will differ depending on the state of the camera.

If you are unable to solve the problem even after trying the following corrective actions a few times, your camera may need repair. Contact your Sony dealer or local authorized Sony service facility.

C:32:□□

- There is trouble with your camera's hardware. Turn the power off and on again.

C:13:□□

- The camera cannot read or write data on the "Memory Stick Duo". Try turning off and on the camera again, or taking out and inserting the "Memory Stick Duo" several times.
- The internal memory has experienced a format error, or an unformatted "Memory Stick Duo" is inserted. Format the internal memory or the "Memory Stick Duo" (pages 68, 70).
- The inserted "Memory Stick Duo" cannot be used with your camera, or the data is damaged. Insert a new "Memory Stick Duo".

E:61:□□

E:62:□□

E:91:□□

- A camera malfunction has occurred. Initialize the camera (page 71), then turn the power on again.

Messages

If the following messages appear, follow the instructions.



- The battery level is low. Charge the battery pack immediately. Depending on the conditions of use or the type of battery pack, the indicator may flash even though there are still 5 to 10 minutes of remaining battery charge left.

For use with compatible battery only

- The battery inserted is not an NP-BD1/ NP-FD1 battery pack.

System error

- Turn the power off and then on again.

Internal memory error

- Turn the power off and then on again.

Reinsert the Memory Stick

- Insert the "Memory Stick Duo" correctly.
- The inserted "Memory Stick Duo" cannot be used in your camera (page 121).
- The "Memory Stick Duo" is damaged.
- The terminal section of the "Memory Stick Duo" is dirty.

Memory Stick type error

- The inserted "Memory Stick Duo" cannot be used in your camera (page 121).

Cannot access Memory Stick Access denied

- You are using the "Memory Stick Duo" with the access controlled.

Memory Stick formatting error Internal memory formatting error

- Format the media again (pages 68, 70).

Memory Stick locked

- You are using the “Memory Stick Duo” with the write-protect switch, and the switch is set to the LOCK position. Set the switch to the recording position.

No memory space in internal memory No memory space on Memory Stick

- Delete unnecessary images or files (page 37).

Read only memory

- Your camera cannot record or delete images on this “Memory Stick Duo”.

No images

- No images that can be played have been recorded in the internal memory.
- No images that can be played have been recorded in this folder.
- The selected folder does not contain a file that can be played in a Slide Show with music.

Folder error

- A folder with the same first three digit number already exists on the “Memory Stick Duo” (for example: 123MSDCF and 123ABCDE). Select another folder, or create a new folder (pages 68, 69).

Cannot create more folders

- The folder with a name beginning with “999” exists on the “Memory Stick Duo”. You cannot create any folders if this is the case.

File error

- An error occurred while the image was playing back.
- When an image file has been processed by a computer or when the image file was recorded using a model other than that of your camera, playback on your camera is not guaranteed.

Read only folder

- You have selected a folder that cannot be set as a recording folder on your camera. Select another folder (page 69).

File protect

- Release the protection (page 61).

Image size over

- You are playing back an image with size that cannot be played back on your camera.

Invalid operation

- You are trying to playback a file that is not compatible with the camera.
- You have selected a function that is not available for movies.
- You have touched the panel when using the digital zoom or close focus mode. While using these modes, you cannot focus by touching the screen.
- You are trying to resize the VGA size image to  (HDTV) with the Multi Resizing function.



(Vibration warning indicator)

- Camera shake may occur due to insufficient light. Use the flash, turn on the anti-blur function, or mount the camera on a tripod to secure the camera.

640(Fine) is not available

- 640(Fine) size movies can be recorded only using a “Memory Stick PRO Duo”. Insert a “Memory Stick PRO Duo” or set the image size to a size other than [640(Fine)].

Macro is invalid

- The macro is unavailable under these settings (pages 30, 45).

Flash settings cannot be changed

- The flash is unavailable under these settings (pages 29, 45).

Zoom disabled

- [Digital Zoom] is set to [Off] when you are shooting in [Close focus enabled]. Or, you are trying to use [Smart] in [Digital Zoom] when the image size is set to [8M] or [3:2] (page 76).

Maximum images selected

- You can select up to 100 images. Remove the check mark.

No enough battery

- When copying a image recorded in the internal memory to the “Memory Stick Duo”, use a fully charged battery.

Printer busy

Paper error

No paper

Ink error

Low ink

No ink

- Check the printer.

Printer error

- Check the printer.
- Check if the image you want to print is corrupted.



- The data transmission to the printer may not be completed yet. Do not disconnect the cable for multi-use terminal.

Processing...

- The printer is canceling the current print job. You cannot print until it is finished. This may take time, depending on the printer.

Music error

- Delete the Music file, or replace it with a normal Music file.
- Execute [Format Music], then download a new Music files.

Format music error

- Execute [Format Music].

Invalid operation

HD(1080i) output in progress...

- You are trying to play back movies.
- You are trying to use the [Retouch] function.

TV output in progress...

- The camera is playing back images in the Slide Show mode.

No red-eye detected

- You may not be able to correct the red-eye phenomenon depending on the image.



Using your camera abroad — Power sources

You can use your camera, the battery charger (supplied), and the AC-LS5K AC Adaptor (not supplied) in any country or region where the power supply is within 100 V to 240 V AC, 50/60 Hz.

- **Do not use an electronic transformer (travel converter), as this may cause a malfunction.**

On the “Memory Stick Duo”

A “Memory Stick Duo” is a compact, portable IC recording medium. The types of “Memory Stick Duo” that can be used with this camera are listed in the table below. However, proper operation cannot be guaranteed for all “Memory Stick Duo” functions.

“Memory Stick” type	Recording/ Playback
Memory Stick Duo (without MagicGate)	○*2
Memory Stick Duo (with MagicGate)	○*1
MagicGate Memory Stick Duo	○*1+2
Memory Stick PRO Duo	○*1+4
Memory Stick PRO-HG Duo	○*1+3+4

*1 “Memory Stick Duo”, “MagicGate Memory Stick Duo” and “Memory Stick PRO Duo” are equipped with MagicGate functions. MagicGate is copyright protection technology that uses encryption technology. Data recording/playback that requires MagicGate functions cannot be performed with this camera.

*2 High-speed data transfer using a parallel interface is not supported.

*3 This camera does not support 8-bit parallel data transfer. It performs the same 4-bit parallel data transfer as the Memory Stick PRO Duo.

*4 [640(Fine)] size movies can be recorded.

- This product is compatible with “Memory Stick Micro” (“M2”). “M2” is an abbreviation for “Memory Stick Micro”.
- A “Memory Stick Duo” formatted with a computer is not guaranteed to operate with this camera.
- Data read/write speeds differ depending on the combination of the “Memory Stick Duo” and the equipment used.
- Do not remove the “Memory Stick Duo” while reading or writing data.
- Data may be corrupted in the following cases:
 - When the “Memory Stick Duo” is removed or the camera is turned off during a read or write operation
 - When the “Memory Stick Duo” is used in locations subject to static electricity or electrical noise
- We recommend backing up important data.
- Do not press down hard when you write down on the memo area.
- Do not attach a label on the “Memory Stick Duo” itself nor on a Memory Stick Duo Adaptor.
- When you carry or store the “Memory Stick Duo”, put it in the case supplied with it.
- Do not touch the terminal section of the “Memory Stick Duo” with your hand or a metal object.
- Do not strike, bend or drop the “Memory Stick Duo”.
- Do not disassemble or modify the “Memory Stick Duo”.
- Do not expose the “Memory Stick Duo” to water.
- Do not leave the “Memory Stick Duo” within the reach of small children. They might accidentally swallow it.
- Do not insert anything other than a “Memory Stick Duo” into the “Memory Stick Duo” slot. Doing so will cause a malfunction.
- Do not use or store the “Memory Stick Duo” under the following conditions:
 - High temperature locations such as the hot interior of a car parked in direct sunlight
 - Locations exposed to direct sunlight
 - Humid locations or locations with corrosive substances present

Notes on using the Memory Stick Duo Adaptor (not supplied)

- To use a “Memory Stick Duo” with a “Memory Stick” compliant device, be sure to insert the “Memory Stick Duo” into a Memory Stick Duo Adaptor. If you insert a “Memory Stick Duo” into a “Memory Stick” compliant device without a Memory Stick Duo Adaptor, you might not be able to remove it from the device.
- When inserting a “Memory Stick Duo” into a Memory Stick Duo Adaptor, make sure the “Memory Stick Duo” is inserted facing in the correct direction, then insert it all the way in. Incorrect insertion may result in a malfunction.
- When using a “Memory Stick Duo” inserted into a Memory Stick Duo Adaptor with a “Memory Stick” compliant device, make sure that the Memory Stick Duo Adaptor is inserted facing the correct direction. Note that improper use may damage the equipment.
- Do not insert a Memory Stick Duo Adaptor into a “Memory Stick” compliant device without a “Memory Stick Duo” attached. Doing so may result in malfunction of the unit.

Notes on using “Memory Stick PRO Duo” (not supplied)

“Memory Stick PRO Duo” with a capacity up to 8 GB have been confirmed to operate properly with this camera.

Notes on using “Memory Stick Micro” (not supplied)

- To use a “Memory Stick Micro” with this camera, be sure to insert the “Memory Stick Micro” into an “M2” Adaptor as large as of Duo size. If you insert a “Memory Stick Micro” into the camera without an “M2” Adaptor as large as of Duo size, you might not be able to remove it from the camera.
- Do not leave the “Memory Stick Micro” within the reach of small children. They might accidentally swallow it.

On the battery pack

On charging the battery pack

We recommend charging the battery pack in an ambient temperature of between 10°C to 30°C (50°F to 86°F). You may not be able to efficiently charge the battery pack outside of this temperature range.

Effective use of the battery pack

- Battery performance decreases in low temperature surroundings. So, the time that the battery pack can be used is shorter in cold places. We recommend the following to ensure longer battery pack use:
 - Put the battery pack in a pocket close to your body to warm it up, and insert it in your camera immediately before you start shooting.
- The battery pack will run out quickly if you use the flash or zoom frequently.
- We recommend having spare battery packs handy for two or three times the expected shooting time, and making trial shots before taking the actual shots.
- Do not expose the battery pack to water. The battery pack is not water-resistant.
- Do not leave the battery pack in extremely hot places, such as in a car or under direct sunlight.

How to store the battery pack

- If the battery pack is not to be used for a long time, fully charge it and then fully use it up once a year on your camera before storing the battery pack in a dry, cool place. Repeat this charging and using up once a year to maintain the battery pack's function.
- To use the battery pack up, leave your camera in slide show (page 54) playback mode until the power goes off.
- To prevent staining the terminal, short-circuiting, etc., be sure to use a supplied battery case when carrying and storing.

On battery life

- The battery life is limited. Battery capacity decreases little by little as you use it more and more, and as time passes. If the battery operating time seems shortened considerably, a probable cause is that the battery pack has reached the end of its life. Buy a new battery pack.
- The battery life varies according to how it is stored and the operating conditions and environment in which each battery pack is used.

Compatible battery pack

- The NP-BD1 (supplied) can be used only in D type compatible Cyber-shot models. It cannot be used in Cyber-shot models compatible with the T type and other battery types.
- If the NP-FD1 battery pack (not supplied) is used, the minute display (🕒 60 Min) is also shown after the battery remaining indicator.

On the battery charger

On the battery charger

- Only D-type, T-type, R-type and E-type battery packs (and no others) can be charged in the battery charger (supplied). Batteries other than the specified kind may leak, overheat, or explode if you attempt to charge them, posing a risk of injury from electrocution and burns.
- The batteries that are compatible with this camera are D type batteries. The supplied battery is NP-BD1 (D type).
- Remove the charged battery pack from the battery charger. If you leave the charged battery pack in the charger, battery life may be shortened.
- If the CHARGE lamp flashes, remove the battery that is being charged and then reinsert it correctly. If the CHARGE lamp flashes again, the battery may be malfunctioning or a battery other than the specified kind may have been inserted. Check that the battery is of the specified kind.

If the inserted battery is of the specified kind, remove the battery and insert a different or new battery to check whether the battery charger is working properly. If the battery charger is working properly, the battery is probably malfunctioning.

On Cyber-shot Station

On Cyber-shot Station

The following Cyber-shot Station (not supplied) are compliant to your camera.

- CSS-HD1 (with the remote controller)
- CSS-PC1

Using the Cyber-shot Station (not supplied) enables faster charging than the supplied battery charger and easy connection to a TV or computer.

For details, refer to the operating instructions supplied with the Cyber-shot Station.

Placing the camera on the Cyber-shot Station

Before mounting the camera to the Cyber-shot Station, the adaptor plate supplied with this camera must be mounted.

Placing the adaptor plate

- ① Set the MODEL SELECT switch to A.
- ② Place the adaptor plate on the Cyber-shot Station.

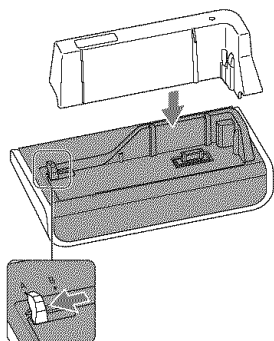

- ③ Placing the camera on the Cyber-shot Station.

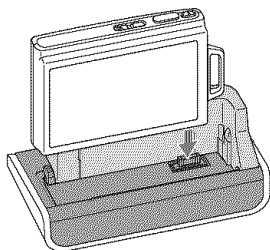

Operating the Cyber-shot Station with the remote

When the remote supplied with the CSS-HD1 is used with this camera, the following operations are available.

- For details on buttons not described here, refer to the instruction manual supplied with the Cyber-shot Station.

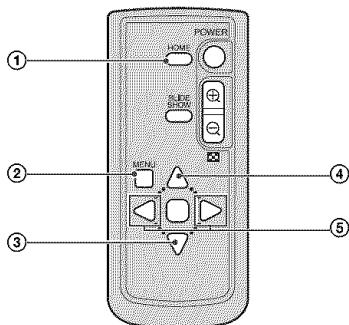

① **HOME button:** This button is invalid.

② **MENU button:** Displays the setting screen of the Slide show (page 54).

- The slideshow setting screen is different during remote control operation, but the setting items are the same.

③ **▼ button:** Plays back the image in Wide Zoom Display (page 60).

④ **▲ button:** Changes the screen display.

⑤ **◀/▶ button:** Displays the previous/next image.

**Numerics**

16:9	74
4:3	74

A

Adaptor plate	125
Adjusting EV	34
AE/AF lock indicator.....	27
AF Illuminator	75
AF Mode.....	76
AF range finder frame	31
AF range finder frame indicator	31
Aperture	10
Auto Adjustment mode.....	26
Auto Focus.....	8
Auto Orientation	78
Auto Review.....	78

B

B & W.....	51
Battery charger.....	124
Battery pack	123
Beach mode	44
Beep.....	71
Blur	9
Burst.....	47

C

Cable for multi-use terminal	81, 90, 102
Calibration	72
Center AF	31
Center-weighted metering	33
Change REC.Folder.....	69
Clock Settings.....	79
Close focus	30
Cloudy	49
Color	11, 66
Color Mode.....	50

COMPONENT.....	73
Computer.....	85
Copying images	90, 98
Macintosh.....	98
Recommended environment	86, 98
Software.....	87
Viewing image files stored on a computer with your camera.....	96
Windows.....	85

Connecting

Computer	90
Printer.....	102
TV	81, 83

Copy	69
Copying images to your computer	90, 94
Create REC.Folder	68
Cross Filter	58

D

Date	79, 104
Daylight.....	49
Delete	37, 61
Format.....	68, 70
Deleting images.....	37
Digital Zoom	76
DirectX.....	87
DISP	23
Download Music	97
DPOF	63, 105

E

Electronic transformer.....	120
EV	34
Exposure.....	10
Exposure Bracket	48
Extension.....	96

F

Face Detection	52
Fast forward/Rewind	35
File name	92
File storage destination.....	92
Fireworks mode	44
Fisheye Lens	58
Flash	29
Flash (Shooting)	14
Flash (White Balance)	49
Flash Level	51
Flash mode.....	29
Flash Off.....	29
Flash On.....	29
Flexible Spot AF.....	31
Fluorescent Light 1, 2, 3.....	49
Focus.....	8, 27, 31
Focus preset	32
Folder.....	64
Changing	69
Creating	68
Selecting	64
Format.....	68, 70
Format Music.....	97
Function Guide	71

G

Grid Line	76
-----------------	----

H

HD(1080i).....	73
High Sensitivity mode	44
Hi-Speed Shutter mode.....	44
Histogram	24
HOME	39, 43, 54, 67
HOME items.....	40
Housing.....	72

- I**
- Identifying parts 15
 - Image file storage destinations and file names 92
 - Image Index 54
 - Image quality 12
 - Image size 12, 28
 - Incandescent 49
 - Index screen 36
 - Indicator 17
 - Initialize 71
 - Install 87
 - Internal memory 25
 - Internal Memory Tool 70
 - ISO 10, 11, 34
- J**
- JPG 93
- L**
- Landscape mode 44
 - Language Setting 80
 - LCD Screen 23
- M**
- Macintosh computer 98
 - Recommended environment 98
 - Macro 30
 - Main Settings 1 71
 - Main Settings 2 73
 - Manage Memory 40, 68
 - Mass Storage 73
 - “Memory Stick Duo” 121
 - Memory Stick Tool 68
 - Menu
 - Items 42
 - Shooting 43, 47
 - Viewing 57
 - Metering Mode 33
 - Monitor 76
 - Movie Mode 43
 - MPG 93
 - Multi AF 31
 - Multi connector
 - 15, 16, 81, 90, 102
 - Multi Resizing 60
 - Multi-pattern metering 33
 - Music 55
 - Music Tool 97
 - Music Transfer 97, 99
- N**
- Natural 50
 - Normal 50
 - NR slow shutter 19
 - NTSC 74
- O**
- Optical zoom 28, 76
 - OS 86, 98
 - Overexposure 10
- P**
- Paint 59, 65
 - Paint pen 65
 - PAL 74
 - Partial Color 57
 - PC 85
 - PictBridge 73, 102
 - Picture Motion Browser
 - 89, 94
 - Pixel 12
 - Playback zoom 36
 - Precision digital zoom 76
 - Pressing halfway down 8
 - Print 63, 101
 - Print order mark 105
 - Printing at a shop 105
 - Printing directly 102
 - Printing, Other 40
 - Program Auto mode 43
 - Protect 61
- R**
- Radial Blur 59
 - REC Mode 47
 - Red Eye Correction 58
 - Red Eye Reduction 52
 - Retouch 57
 - Retro 59
 - Rotate 63
- S**
- Scene Selection 44
 - Screen
 - Changing the display 23
 - Indicator 17
 - LCD backlight 23
 - SD 73
 - Select Folder 64
 - Self-diagnosis display 117
 - Self-timer 28
 - Sepia 51
 - Settings 40, 71
 - Setup 53
 - Shooting 40, 43
 - Movies 27
 - Still image 26
 - Shooting menu 47
 - Shooting Settings 1 75
 - Shooting Settings 2 78
 - Shutter speed 10
 - Single 76
 - Single Image 54
 - Slideshow 54, 61
 - Slow Synchro 29
 - Smart zoom 76
 - Smile Level 78
 - Smile Shutter 46

Snow mode	44
Soft Focus	57
Soft Snap mode	44
Software	87, 89, 97
Spot AF	31
Spot metering	33
Spot metering cross hairs	33
SteadyShot	53

T

Touch panel	22
Trimming	58
Troubleshooting	107
TV	81
TV TYPE	74
Twilight mode	44
Twilight Portrait mode	44

U

Underexposure	10
USB Connect	73
Using your camera abroad	120

V

VGA	13
Video Out	74
View Images	40
Viewing images	35
Viewing menu	57
Vivid	50
Volume	35
Volume Settings	64

W

Warning indicators and messages	117
White Balance	49
Wide Zoom Display	60
Windows computer	85
Recommended environment	86

Z

Zoom	28, 36
------------	--------

Notes on the License

“C Library”, “Expat” and “zlib” software are provided in your camera. We provide this software based on license agreements with their owners of copyright. Based on requests by the owners of copyright of these software applications, we have an obligation to inform you of the following. Please read the following sections.

Read “license1.pdf” in the “License” folder on the CD-ROM. You will find licenses (in English) of “C Library”, “Expat” and “zlib” software.

On GNU GPL/LGPL applied software

The software that is eligible for the following GNU General Public License (hereinafter referred to as “GPL”) or GNU Lesser General Public License (hereinafter referred to as “LGPL”) are included in the camera.

This informs you that you have a right to have access to, modify, and redistribute source code for these software programs under the conditions of the supplied GPL/LGPL.

Source code is provided on the web. Use the following URL to download it.

<http://www.sony.net/Products/Linux/>

We would prefer you do not contact us about the contents of source code.

Read “license2.pdf” in the “License” folder on the CD-ROM. You will find licenses (in English) of “GPL”, and “LGPL” software.

To view the PDF, Adobe Reader is needed. If it is not installed on your computer, you can download it from the Adobe Systems web page:

<http://www.adobe.com/>

Additional information on this product and answers to frequently asked questions can be found at our Customer Support Website.

<http://www.sony.net/>