

SEARS

**OWNER'S
MANUAL**

**MODEL NO.
917.255561**

Caution:

Read and follow
all Safety Rules
and Instructions
Before Operating
This Equipment

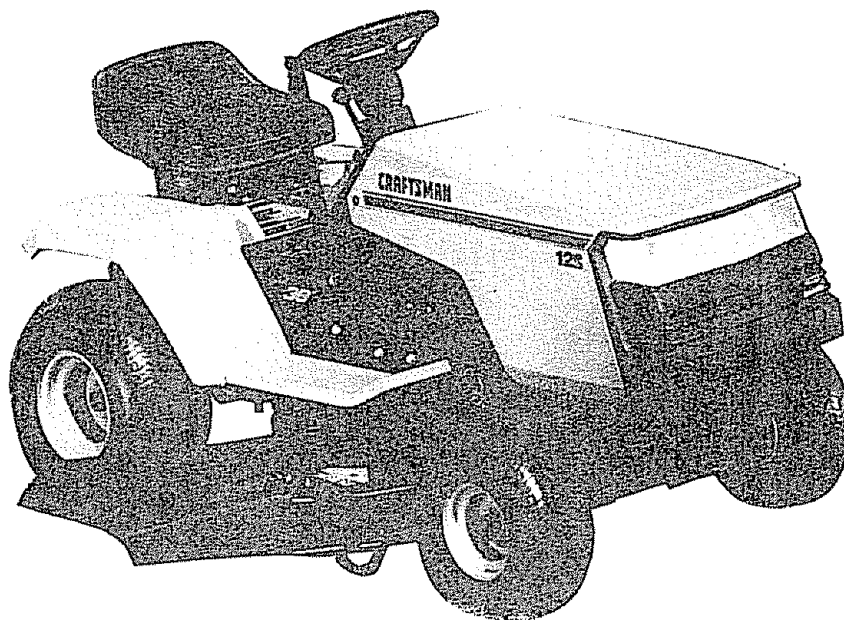

CRAFTSMAN[®]

**12.0 HP IC
ELECTRIC START
38" MOWER DECK
5 SPEED TRANSAXLE
LAWN TRACTOR**

- Assembly
- Operation
- Customer Responsibilities
- Service and Adjustment
- Repair Parts



SAFETY RULES

Safe Operation Practices for Ride-On Mowers



IMPORTANT: THIS CUTTING MACHINE IS CAPABLE OF AMPUTATING HANDS AND FEET AND THROWING OBJECTS. FAILURE TO OBSERVE THE FOLLOWING SAFETY INSTRUCTIONS COULD RESULT IN SERIOUS INJURY OR DEATH.

I. GENERAL OPERATION

- Read, understand, and follow all instructions in the manual and on the machine before starting.
- Only allow responsible adults, who are familiar with the instructions, to operate the machine.
- Clear the area of objects such as rocks, toys, wire, etc., which could be picked up and thrown by the blade.
- Be sure the area is clear of other people before mowing. Stop machine if anyone enters the area.
- Never carry passengers.
- Do not mow in reverse unless absolutely necessary. Always look down and behind before and while backing.
- Be aware of the mower discharge direction and do not point it at anyone. Do not operate the mower without either the entire grass catcher or the guard in place.
- Slow down before turning.
- Never leave a running machine unattended. Always turn off blades, set parking brake, stop engine, and remove keys before dismounting.
- Turn off blades when not mowing.
- Stop engine before removing grass catcher or unclogging chute.
- Mow only in daylight or good artificial light.
- Do not operate the machine while under the influence of alcohol or drugs.
- Watch for traffic when operating near or crossing roadways.
- Use extra care when loading or unloading the machine into a trailer or truck.

II. SLOPE OPERATION

Slopes are a major factor related to loss-of-control and tipover accidents, which can result in severe injury or death. All slopes require extra caution. If you cannot back up the slope or if you feel uneasy on it, do not mow it.

DO:

- Mow up and down slopes, not across.
- Remove obstacles such as rocks, tree limbs, etc.
- Watch for holes, ruts, or bumps. Uneven terrain could overturn the machine. *Tall grass can hide obstacles.*
- Use slow speed. Choose a low gear so that you will not have to stop or shift while on the slope.
- Follow the manufacturer's recommendations for wheel weights or counterweights to improve stability.
- Use extra care with grass catchers or other attachments. These can change the stability of the machine.
- Keep all movement on the slopes *slow and gradual*. Do not make sudden changes in speed or direction.
- Avoid starting or stopping on a slope. If tires lose traction, disengage the blades and proceed slowly *straight* down the slope.

DO NOT:

- *Do not* turn on slopes unless necessary, and then, turn slowly and gradually downhill, if possible.
- *Do not* mow near drop-offs, ditches, or embankments. The mower could suddenly turn over if a wheel is over the edge of a cliff or ditch, or if an edge caves in.
- *Do not* mow on wet grass. Reduced traction could cause sliding.
- *Do not* try to stabilize the machine by putting your foot on the ground.
- *Do not* use grass catcher on steep slopes.

III. CHILDREN

Tragic accidents can occur if the operator is not alert to the presence of children. Children are often attracted to the machine and the mowing activity. *Never* assume that children will remain where you last saw them.

- Keep children out of the mowing area and under the watchful care of another responsible adult.
- Be alert and turn machine off if children enter the area.
- Before and when backing, look behind and *down* for small children.
- Never carry children. They may fall off and be seriously injured or interfere with safe machine operation.
- Never allow children to operate the machine.
- Use extra care when approaching blind corners, shrubs, trees, or other objects that may obscure vision.

IV. SERVICE

- Use extra care in handling gasoline and other fuels. They are flammable and vapors are explosive.
 - Use only an approved container.
 - Never remove gas cap or add fuel with the engine running. Allow engine to cool before refueling. Do not smoke.
 - Never refuel the machine indoors.
 - Never store the machine or fuel container inside where there is an open flame, such as a water heater.
- Never run a machine inside a closed area.
- Keep nuts and bolts, especially blade attachment bolts, tight and keep equipment in good condition.
- Never tamper with safety devices. Check their proper operation regularly.
- Keep machine free of grass, leaves, or other debris build-up. Clean oil or fuel spillage. Allow machine to cool before storing.
- Stop and inspect the equipment if you strike an object. Repair, if necessary, before restarting.
- Never make adjustments or repairs with the engine running.
- Grass catcher components are subject to wear, damage, and deterioration, which could expose moving parts or allow objects to be thrown. Frequently check components and replace with manufacturer's recommended parts, when necessary.
- Mower blades are sharp and can cut. Wrap the blade(s) or wear gloves, and use extra caution when servicing them.
- Check brake operation frequently. Adjust and service as required.



Look for this symbol to point out important safety precautions. It means **CAUTION!!! BECOME ALERT!!! YOUR SAFETY IS INVOLVED.**



CAUTION: Always disconnect spark plug wire and place wire where it cannot contact spark plug in order to prevent accidental starting when setting up, transporting, adjusting or making repairs.

CONGRATULATIONS on your purchase of a Sears tractor. It has been designed, engineered and manufactured to give you the best possible dependability and performance.

Should you experience any problem you cannot easily remedy, please contact your nearest Sears Service Center/Department. We have competent, well-trained technicians and the proper tools to service or repair this tractor.

Please read and retain this manual. The instructions will enable you to assemble and maintain your tractor properly. Always observe the "SAFETY RULES".

MODEL NUMBER	917.255561
SERIAL NUMBER	_____
DATE OF PURCHASE	_____
THE MODEL AND SERIAL NUMBERS WILL BE FOUND ON A PLATE UNDER THE SEAT.	
YOU SHOULD RECORD BOTH SERIAL NUMBER AND DATE OF PURCHASE AND KEEP IN A SAFE PLACE FOR FUTURE REFERENCE.	

MAINTENANCE AGREEMENT

A Sears Maintenance Agreement is available on this tractor. Contact your nearest Sears store for details.

CUSTOMER RESPONSIBILITIES

- Read and observe the safety rules.
- Follow a regular schedule in maintaining, caring for and using your tractor.
- Follow the instructions under "Customer Responsibilities" and "Storage" sections of this manual.

PRODUCT SPECIFICATIONS

HORSEPOWER:	12.0
GASOLINE CAPACITY:	5 QUARTS UNLEADED REGULAR
OIL (3.0 PINTS):	SAE 30 (Above 32°F) 5W-30(Below 32°F)
SPARK PLUG (GAP.030 IN.):	CHAMPION RJ-19LM STD361458
VALVE CLEARANCE:	INTAKE .005 - .007 IN . EXHAUST .009 - .011 IN .
GROUND SPEED:	FORWARD 1st 1.10 MPH 2nd 2.00 MPH 3rd 3.00 MPH 4th 4.20 MPH 5th 5.00 MPH REVERSE: 1.50 MPH
TIRE PRESSURE:	FRONT: 14 PSI REAR: 10 PSI
CHARGING SYSTEM:	3 AMPS BATTERY 5 AMPS HEADLIGHTS
BLADE BOLT TORQUE:	30-35 FT. LBS.

WARNING: This tractor is equipped with an internal combustion engine and should not be used on or near any unimproved forest-covered, brush-covered or grass-covered land unless the engine's exhaust system is equipped with a spark arrester meeting applicable local or state laws (if any). If a spark arrester is used, it should be maintained in effective working order by the operator.

In the state of California the above is required by law (Section 4442 of the California Public Resources Code). Other states may have similar laws. Federal laws apply on federal lands. A spark arrester for the muffler is available through your nearest Sears Authorized Service Center (See the REPAIR PARTS section of this manual).

LIMITED TWO YEAR WARRANTY ON ELECTRIC START RIDING EQUIPMENT

For two (2) years from the date of purchase, if this riding equipment is maintained, lubricated and tuned up according to the instructions in the owner's manual, Sears will repair or replace, free of charge, any parts found to be defective in material or workmanship.

This Warranty does not cover:

- Expendable items which become worn during normal use, such as blades, spark plugs, air cleaners and belts.
- Tire replacement or repair caused by punctures from outside objects, such as nails, thorns, stumps, or glass.
- Repairs necessary because of operator abuse, negligence, improper storage or accident or the failure to maintain the equipment according to the instructions contained in the owner's manual.
- Riding equipment used for commercial or rental purposes.

LIMITED 90 DAY WARRANTY ON BATTERY

For 90 days from date of purchase, if any battery included with this riding equipment proves defective in material or workmanship and our testing determines the battery will not hold a charge, Sears will replace the battery at no charge.

WARRANTY SERVICE IS AVAILABLE BY RETURNING THE RIDING EQUIPMENT TO THE NEAREST SEARS SERVICE CENTER/DEPARTMENT IN THE UNITED STATES.

This Warranty gives you specific legal rights, and you may also have other rights which may vary from state to state.

SEARS, ROEBUCK AND CO., D/731CR-W, SEARS TOWER, CHICAGO, ILLINOIS 60684

TABLE OF CONTENTS

SAFETY RULES	2	OPERATION	10-13
PRODUCT SPECIFICATIONS	3	MAINTENANCE SCHEDULE	14
CUSTOMER RESPONSIBILITIES	3, 14-17	SERVICE AND ADJUSTMENTS	18-23
WARRANTY	3	STORAGE	24
TABLE OF CONTENTS	4	TROUBLESHOOTING	25-26
INDEX	4	REPAIR PARTS - TRACTOR	28-43
TRACTOR ACCESSORIES	5	REPAIR PARTS - ENGINE	44-48
ASSEMBLY	7-9	PARTS ORDERING/SERVICE	BACK PAGE

INDEX

A		E		Operation		10-13
Accessories	5	Electrical:		Operating Mower	12	
Adjustments:		Interlocks and Relays	22	Options:		
Brake	20	Schematic	27	Accessories	5	
Carburetor	23	Wiring Diagram	28	Spark Arrester	3,38	
Mower		Engine:		P		
Front-To-Back	19	Air Filter	17	Parking Brake	10-11	
Side-To-Side	19	Air Filter Foam Pre-Cleaner	17	Parts Bag	6	
Throttle Control Cable	23	Air Screen	17	Parts, Replacement/Repair	28-43	
Air Filter, Engine	17	Cooling Fins, Engine	17	Product Specifications	3	
Air Screen, Engine	17	Oil Change	16	R		
Assembly	7-9	Oil Level	12,16	Repair Parts	28-43	
B		Oil Type	16	S		
Battery:		Preparation	12	Safety Rules	2	
Charging	8	Repair Parts	44-48	Seat	8	
Cleaning	16	Starting	13	Service and Adjustments	18-23	
Installation	9	Storage	24	Carburetor	23	
Levels	8,16	F				
Preparation	8	Filter:		Fuse	22	
Starting with Weak Battery	21	Air Filter	17	Hood Removal/Installation	22	
Storage	24	Air Filter Foam Pre-Cleaner	17	Motion Drive Belt		
Terminals	16	Fuel	17	Removal/Replacement	20	
Belt:		Fuel:		Mower Blade Drive Belt		
Motion Drive		Type	12	Removal/Replacement	20	
Removal/Replacement	20	Storage	24	Mower Adjustment		
Mower Blade Drive		Fuse	22	Front-to-Back	19	
Removal/Replacement	20	H				
Blade:		Headlights	22	Side-to-Side	19	
Sharpening	15	Hood Removal/Installation	22	Mower Installation	18	
Replacement	15	L				
Brake Adjustment	20	Leveling Mower Deck	19	Mower Removal	18	
C		Lubrication:		Tire Care	8,15,21	
Carburetor Adjustment	24	Chart	14	Slope Guide Sheet	51	
Controls, Tractor	10	M				
Customer Responsibilities	14-17	Maintenance Schedule	14	Spark Plugs	17	
Engine:		Mower:		Specifications	3	
Air Filter	17	Adjustment, Front-to-Back	19	Starting the Engine	12-13	
Air Filter Foam Pre-Cleaner	17	Adjustment, Side-to-Side	19	Steering Wheel	7,21	
Air Screen, Engine	17	Blade Sharpening	15	Stopping the Tractor	11	
Battery	16	Blade Replacement	15	Storage	24	
Cooling Fins, Engine	17	Cutting Height	11	T		
Engine Oil	16	Installation	18	Throttle Control Cable		
Fuel Filter	17	Operation	12	Adjustment	23	
Spark Plugs	17	Removal	18	Tires	8,15,21	
Tractor:		Mowing Tips	13	Trouble Shooting Chart	25-26	
Blade	15	Muffler	17	Transaxle:		
Lubrication Chart	14	Spark Arrester	3,38	Repair Parts	42-43	
Maintenance Schedule	14	O				
Tire Care	8,15,21	Oil:		W		
Cutting Height, Mower	11	Cold Weather Conditions	12,16	Warranty	3	
		Engine	16	Wiring Diagram	28	
		Storage	24	Wiring Schematic	27	

ACCESSORIES AND ATTACHMENTS

These accessories and attachments were available when the tractor was purchased. They are also available at most Sears retail outlets, catalog and service centers. Most Sears stores can order these items for you when you provide the model number of your tractor.

ENGINE

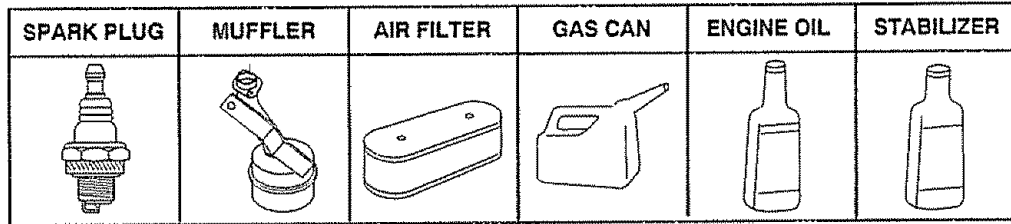

MAINTENANCE

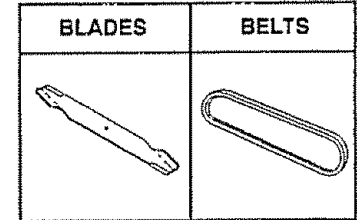

PERFORMANCE

Sears offers a wide variety of attachments that fit your tractor. Many of these are listed below with brief explanations of how they can help you. This list was current at the time of publication; however, it may change in future years - more attachments may be added, changes may be made in these attachments, or some may no longer be available or fit your model. **Contact your nearest Sears store for the accessories and attachments that are available for your tractor.**

Most of these attachments do not require additional hitches or conversion kits (those that do are indicated) and are designed for easy attaching and detaching.

PERMANEX BAGGER lets you collect grass clippings and leaves for a healthier, neater looking lawn. Two Permanex containers hold 30-gallon plastic bags.

LAWN SWEEPERS let you collect grass clippings and leaves.

LAWN VACS for powerful collection of heavy grass clippings and leaves. Wand attachment to pick up debris in hard-to-reach places.

CARTS make hauling easy. Variety of sizes available.

ROLLER for smoother lawn surface. 36-inch wide, 18-inch diameter water-tight drum holds up to 390 lbs. of weight. Rounded edges prevent harm to turf. Adjustable scraper automatically cleans drum.

SPREADER/SEEDERS make seeding, fertilizing, and weed killing easy. Broadcast spreaders are also useful for granular de-icers and sand.

CORING AERATOR takes small plugs out of soil to allow moisture and nutrients to reach grass roots. 36-inch swath. 24 hardened steel coring tips. 150 lb. capacity weight tray.

AERATOR promotes deep root growth for a healthy lawn. Tapered 2.5-inch steel spikes mounted on 10-inch diameter discs puncture holes in soil at close intervals to let moisture soak in. Steel weight tray for increased penetration.

MULCH RAKE/DETHATCHER loosens soil and flips thatch and matted leaves to lawn surface for easy pickup. Twenty spring tine teeth. Useful to prepare bare areas for seeding. Available for front or rear mounting.

SPRAYERS use 12-volt DC electric motor that connects to the tractor battery or other 12-volt source. Includes booms for automatic spraying when pulling, and hand held wand for spot spraying. Wand has adjustable spray pattern. For applying herbicides, insecticides, fungicides, and liquid fertilizers.

SNOW BLADE for snow removal only. 14-inch high, 42-inch wide blade clears 38-inch path when angled left or right. Raises, lowers with side lever. Adjustable skids; replaceable, reversible scraper bar. (Use with tire chains, wheel weights, or rear drawbar weight.)

SNOWTHROWER has 40-inch swath. Drum-type auger handles powdery and wet/heavy snow. Mounts easily with simple pin arrangement. Discharge chute adjusts from tractor seat. 6-inch diameter spout discharges snow 10 to 50 feet. Lift controlled at tractor seat. (Use with chains, wheel weights, or rear drawbar weight.)

TIRE CHAINS are heavy duty; closely spaced extra-large cross links give smooth ride, outstanding traction.

WHEEL WEIGHTS for rear wheels provide needed traction for snow removal or dozing heavy materials. In pairs. (30 lbs. each.)

TRACTOR CAB has heavy duty vinyl fabric over tubular steel frame, ABS plastic top; clear plastic windshield offers 360 degree visibility. Hinged metal doors with catch. Keeps operator warm and dry. Remove vinyl and windshields for use as sun protector in summer. (Catalog only.)

Optional accessories for tractor cab: tinted/tempered solid safety glass windshield with hand operated wiper; 12-volt amber caution light for mounting on cab top. (Catalog only.)

TRACTOR COVER protects tractor from weather. Made of Evolution 3 fabric (water-repellent, extremely breathable, light weight, soft, non-abrasive, pliable in all temperatures, durable, stain/tear/puncture resistant, will not shrink or stretch.) (Catalog only.)

TILLER has 5 hp engine and 36-inch swath to prepare seed beds, cultivate, and compost garden residue. Tiller has its own built-in lift and depth control system and does NOT require a sleeve hitch. Fits any lawn, yard, or garden tractor. Simply hook up to the tractor drawbar and go!

CONTENTS OF HARDWARE PACK

Parts Bag contents shown full size

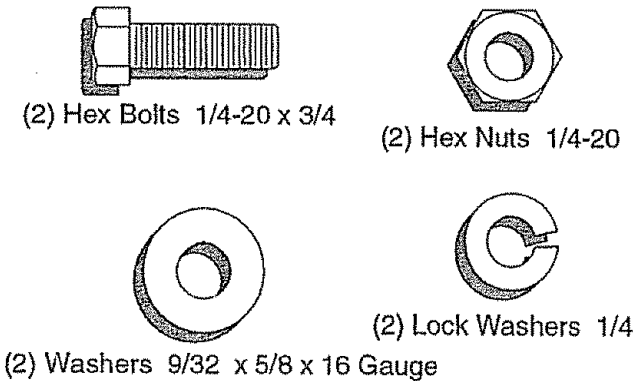
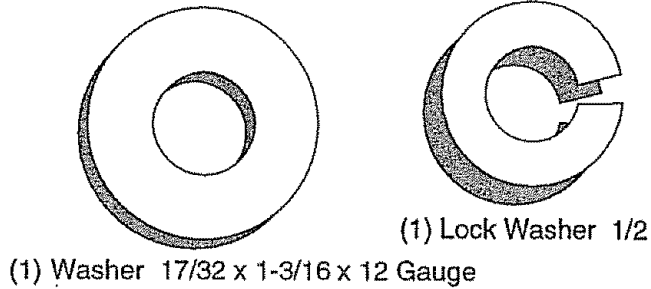
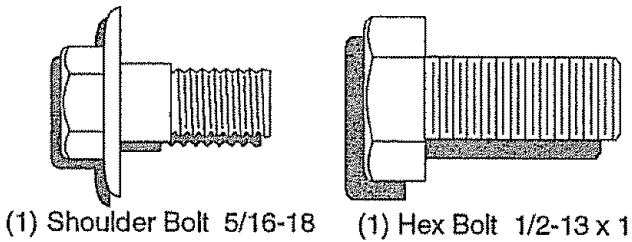
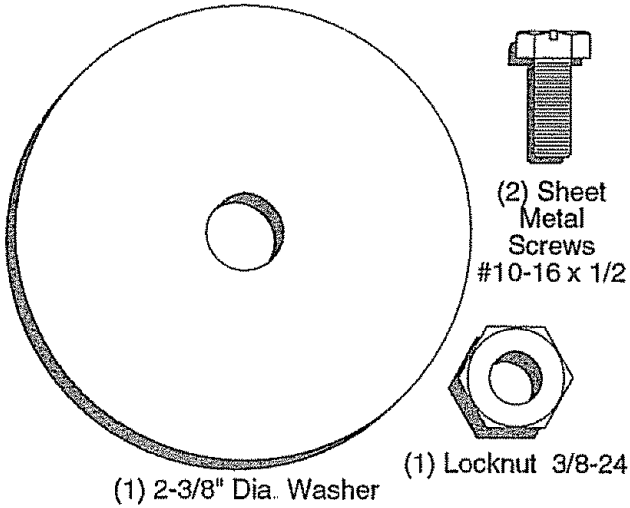

Parts packed separately in carton

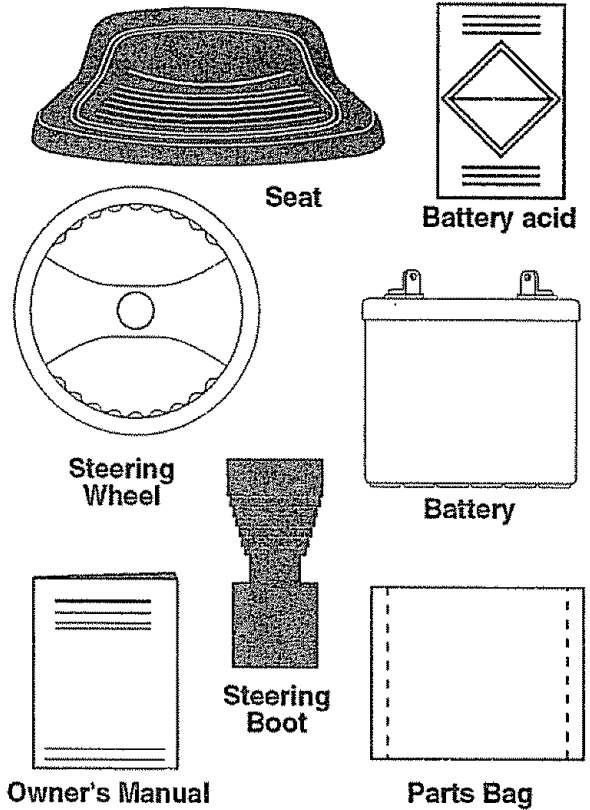

Parts bag contents not shown full size

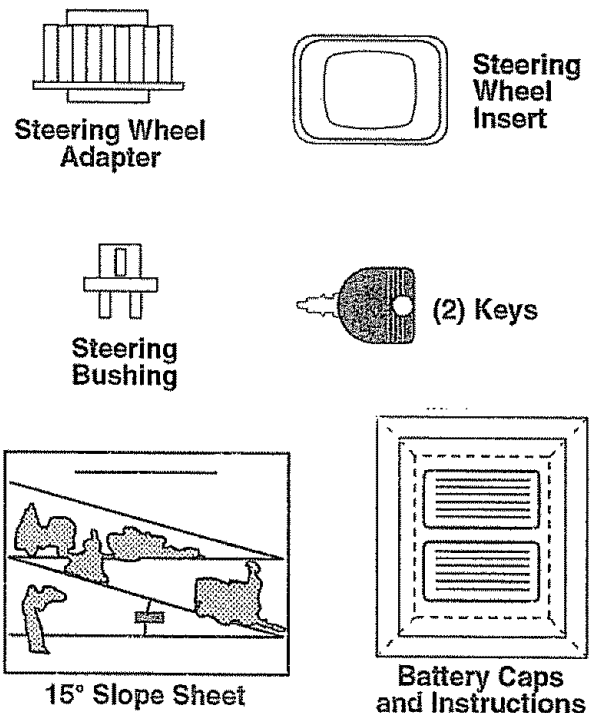

ASSEMBLY

Your new tractor has been assembled at the factory with exception of those parts left unassembled for shipping purposes. To ensure safe and proper operation of your tractor all parts and hardware you assemble must be tightened securely. Use the correct tools as necessary to insure their proper tightness.

TOOLS REQUIRED FOR ASSEMBLY

A socket wrench set will make assembly easier. Standard wrench sizes are listed.

- | | |
|--------------------|---------------------|
| (1) 5/16" wrench | 3/4" wrench |
| (2) 7/16" wrenches | Tire pressure gauge |
| (1) 1/2" wrench | Screwdriver |
| (1) 9/16" wrench | Utility knife |

When right and left hand is mentioned in this manual, it means when you are in the operating position (seated behind the steering wheel).

TO REMOVE TRACTOR FROM CARTON UNPACK CARTON

- Remove all accessible loose parts and parts cartons from carton (See page 6).
- Cut along lines on carton, from top to bottom, all four corners of carton and lay panels flat.
- Check for any additional loose parts or cartons and remove.

BEFORE ROLLING TRACTOR OFF SKID ATTACH STEERING WHEEL (See Fig. 1)

- Slide the steering bushing over the steering shaft.
- Raise steering shaft forward until screw holes in dash line up with steering bushing. Install two (2) sheet metal screws and tighten securely.
- Position steering boot over steering shaft.
- Place tabs of steering boot over slots in dash and push down to secure.
- Slide steering wheel adapter onto upper steering shaft.
- Position front wheels of the tractor so they are pointing straight forward.
- Position steering wheel so cross bars are horizontal (left to right) and slide onto adapter.
- Assemble large flat washer and 3/8-24 hex locknut and tighten securely.
- Snap insert into center of steering wheel.
- Remove protective plastic from tractor hood and grill.

IMPORTANT: CHECK FOR AND REMOVE ANY STAPLES IN SKID THAT MAY PUNCTURE TIRES WHERE TRACTOR IS TO ROLL OFF SKID.

(See Fig. 6)

- Raise attachment lift lever to its highest position.
- Release parking brake by depressing clutch/brake pedal.
- Place gearshift lever in "NEUTRAL" position.
- Roll tractor backwards off skid.
- Remove banding holding discharge guard up against tractor.

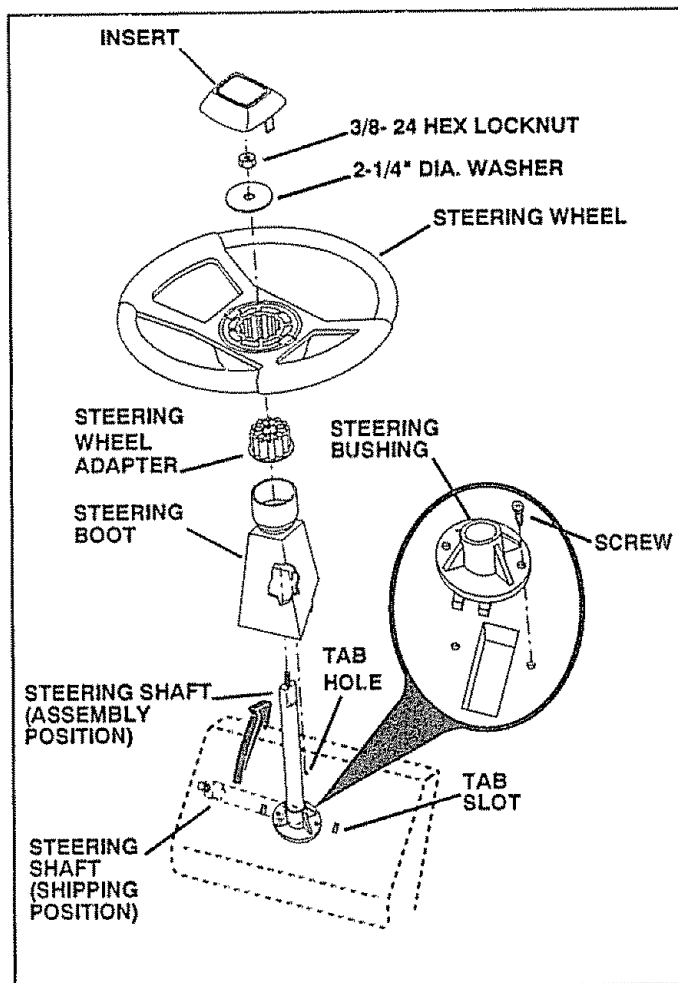

FIG. 1

ASSEMBLY

HOW TO SET UP YOUR TRACTOR

PREPARE BATTERY (See Fig. 2)

CAUTION: Wear eye and face shield.

Wash hands or clothing immediately if accidentally in contact with battery acid.

Do not smoke. Fumes from charged battery acid are explosive.

Read the instructions included with the battery vent caps. Always wear gloves, clothing and goggles to protect your hands, skin and eyes.



Your tractor has a battery charging system which is sufficient for normal use. However, periodic charging of the battery with an automotive charger will extend its life.

- See instructions packed with vent caps in parts bag.
- Fill battery with acid. Fill each cell until it reaches the bottom of the vent wells. Do not overfill.
- Allow battery to stand and settle for at least thirty minutes. After standing, check the level of acid. If below the vent wells, add more acid until the correct level is reached.

While battery is standing (after adding acid) and later, while battery is being charged, continue with assembly of tractor.

IMPORTANT: TO MAXIMIZE THE LIFE OF YOUR BATTERY, IT IS NECESSARY THAT THE BATTERY BE CHARGED BEFORE USE FAILURE TO CHARGE BATTERY CAN RESULT IN A SHORTENED BATTERY LIFE.

- Charge battery at a rate of 6 amperes for 1 hour. Use a 12 volt battery charger. Observe all safety precautions required for battery charging.
- Check the acid level after the battery is charged. If the acid has fallen below the correct level, add distilled or iron free water.
- Install the vent caps to cover the vent wells. Wash the top of the battery with water to remove any acid, then wipe dry.
- Check battery case for leakage to make sure that no damage has occurred in handling.
- Dispose of excess battery acid. Neutralize acid for disposal by adding it to four inches of water in a five gallon plastic container. Stir with a wooden or plastic paddle while adding baking soda until the addition of more soda causes no more foaming.
- Follow instructions on how to install battery.

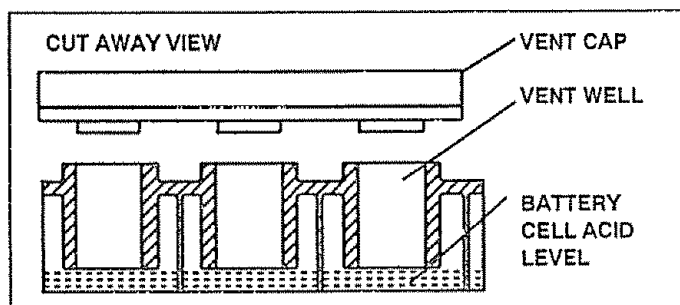

FIG. 2

INSTALL SEAT (See Fig. 3)

Adjust seat before tightening adjustment bolt.

- Remove cardboard packing on seat pan.
- Place seat on pan and assemble shoulder bolt.
- Assemble adjustment bolt, lock washer and flat washer loosely. Do not tighten.
- Tighten shoulder bolt securely.
- Lower seat into operating position and sit on seat.
- Slide seat until a comfortable position is reached which allows you to press clutch/brake pedal all the way down (See Fig. 6).
- Get off seat without moving its adjusted position.
- Raise seat and tighten adjustment bolt securely.

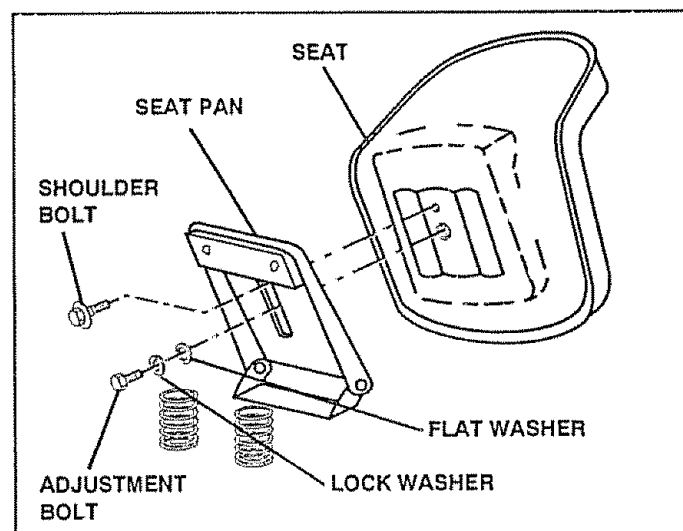

FIG. 3

CHECK TIRE PRESSURE

The tires on your tractor were overinflated at the factory for shipping purposes. Correct tire pressure is important for best cutting performance.

- Reduce tire pressure PSI shown in "PRODUCT SPECIFICATION" on page 3 of this manual.

CHECK DECK LEVELNESS

For best cutting results, mower housing should be properly leveled. See "TO LEVEL MOWER HOUSING" in the Service and Adjustments section of this manual.

CHECK FOR PROPER POSITION OF ALL BELTS

See the figures that are shown for replacing motion and mower blade drive belts in the Service and Adjustments section of this manual. Verify that the belts are routed correctly.

CHECK BRAKE SYSTEM

After you learn how to operate your tractor, check to see that the brake is properly adjusted. See "TO ADJUST BRAKE" in the Service and Adjustments section of this manual.

ASSEMBLY

INSTALL BATTERY (See Figs. 4 & 5)



CAUTION: Do not short battery terminals. Before installing battery, remove metal bracelets, wristwatch bands, rings, etc.

Positive terminal must be connected first to prevent sparking from accidental grounding.

- Lift seat to raised position.
- Open battery box door.
- Lower battery into battery box with battery terminals toward front of tractor.
- Be sure battery drain tube is attached to battery box.
- First connect RED battery cable to positive (+) battery terminal with hex bolt, flat washer, lock washer and hex nut as shown. Tighten securely.
- Connect BLACK grounding cable to negative (-) battery terminal with remaining hex bolt, flat washer, lock washer and hex nut. Tighten securely.
- Close battery box door.

Open battery box door for:

- Inspection for secure connections (to tighten hardware).
- Inspection for corrosion.
- Testing battery.
- Jumping (if required).
- Periodic charging.

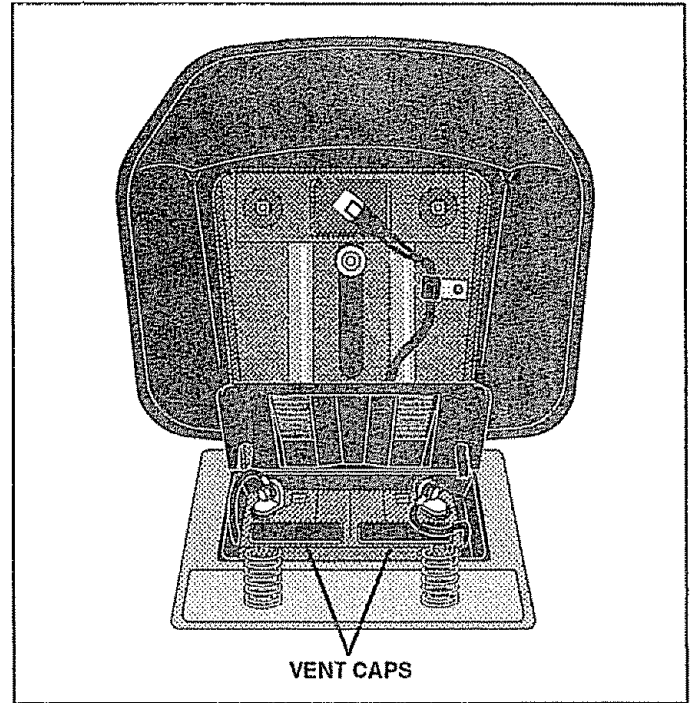

FIG. 5

✓ CHECKLIST

BEFORE YOU OPERATE AND ENJOY YOUR NEW TRACTOR, WE WISH TO ASSURE THAT YOU RECEIVE THE BEST PERFORMANCE AND SATISFACTION FROM THIS QUALITY PRODUCT.

PLEASE REVIEW THE FOLLOWING CHECKLIST:

- ✓ All assembly instructions have been completed.
- ✓ No remaining loose parts in carton.
- ✓ Battery is properly prepared and charged. (Minimum 1 hour at 6 amps).
- ✓ Seat is adjusted comfortably and tightened securely.
- ✓ All tires are properly inflated. (For shipping purposes, the tires were over-inflated at the factory).
- ✓ Be sure mower deck is properly leveled side-to-side/front-to-rear for best cutting results. (Tires must be properly inflated for leveling).
- ✓ Check mower and drive belts. Be sure they are routed properly around pulleys and inside all belt keepers.
- ✓ Check wiring. See that all connections are still secure and wires are properly clamped.

WHILE LEARNING HOW TO USE YOUR TRACTOR, PAY EXTRA ATTENTION TO THE FOLLOWING IMPORTANT ITEMS:

- ✓ Engine oil is at proper level.
- ✓ Fuel tank is filled with fresh, clean, regular unleaded gasoline.
- ✓ Become familiar with all controls - their location and function. Operate them before you start the engine.
- ✓ Be sure brake system is in safe operating condition.

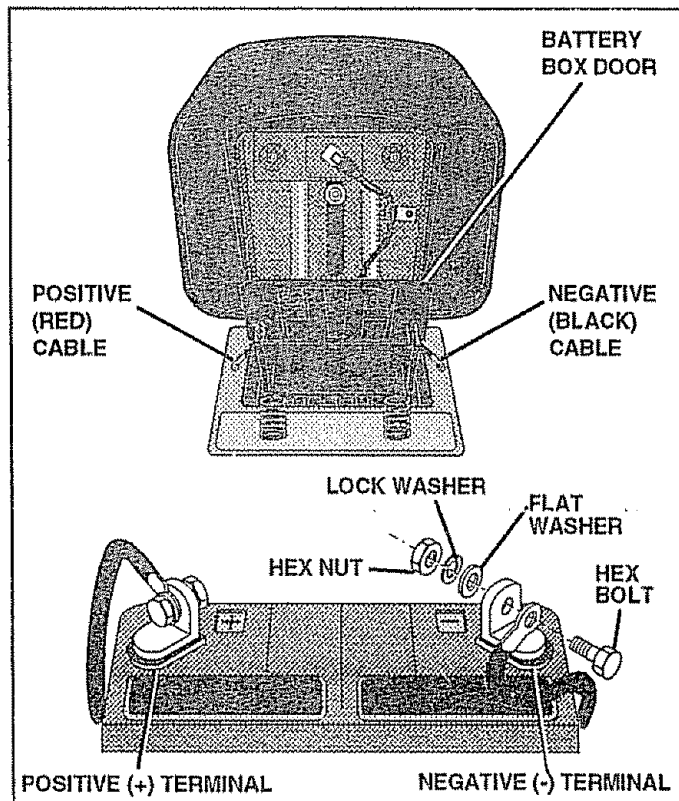

FIG. 4

OPERATION

KNOW YOUR TRACTOR

READ THIS OWNER'S MANUAL AND SAFETY RULES BEFORE OPERATING YOUR TRACTOR

Compare the illustrations with your tractor to familiarize yourself with the locations of various controls and adjustments. Save this manual for future reference.

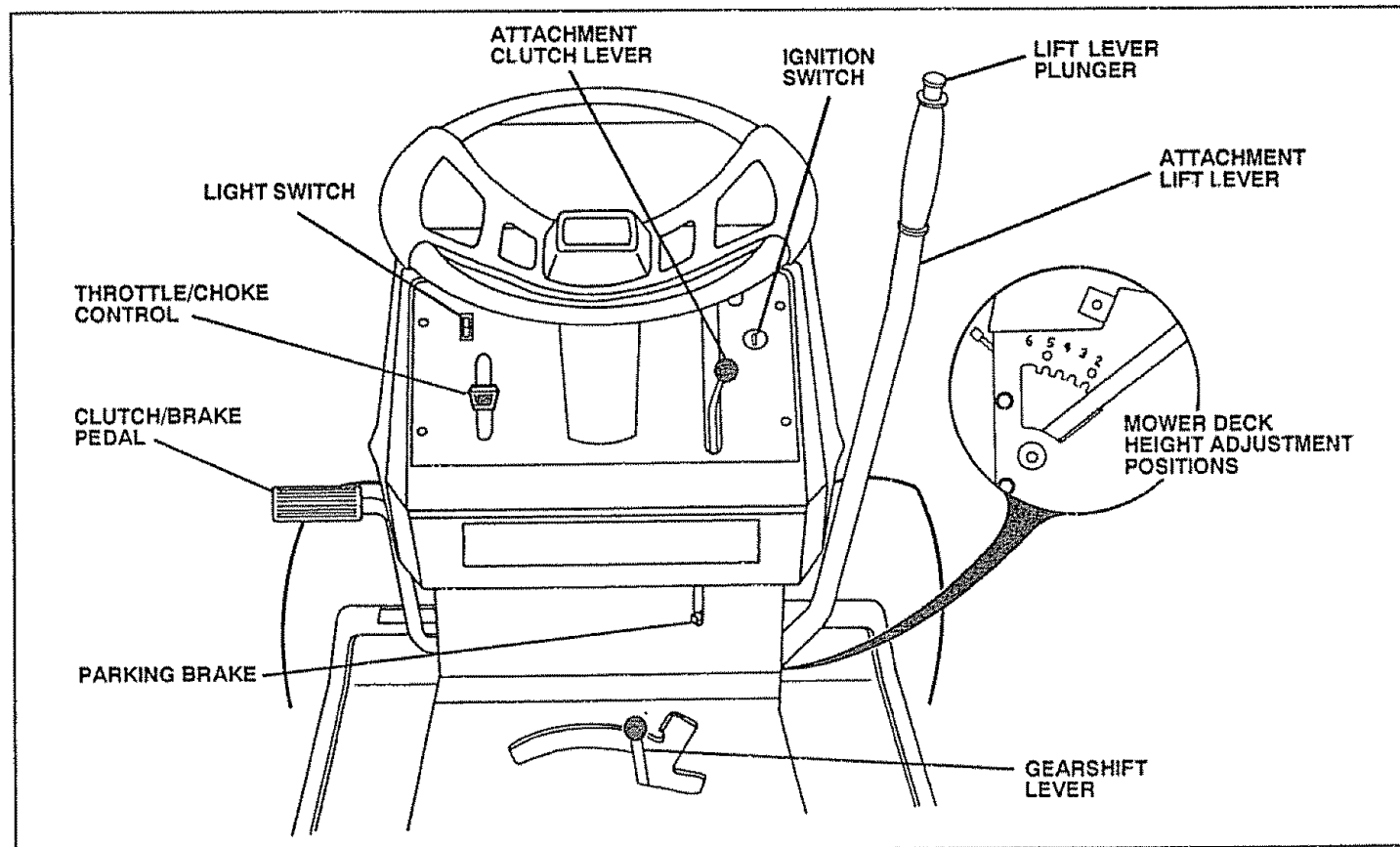

FIG. 6

Sears tractors conform to the safety standards of the American National Standards Institute.

THROTTLE/CHOKE CONTROL: Used for starting and controlling engine speed.

CLUTCH/BRAKE PEDAL: Used for declutching and braking the tractor and starting the engine.

PARKING BRAKE: Locks clutch/brake pedal into the brake position.

IGNITION SWITCH: Used for starting and stopping the engine.

GEARSHIFT LEVER: Selects the speed and direction of tractor.

LIGHT SWITCH: Turns the headlights on and off.

ATTACHMENT CLUTCH LEVER: Used to engage the mower blades, or other attachments mounted to your tractor.

ATTACHMENT LIFT LEVER: Used to raise, lower, and adjust the mower deck or other attachments mounted to your tractor.

LIFT LEVER PLUNGER: Used to release attachment lift lever when changing its position.

OPERATION

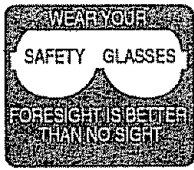

The operation of any tractor can result in foreign objects thrown into the eyes, which can result in severe eye damage. Always wear safety glasses or eye shields while operating your tractor or performing any adjustments or repairs. We recommend wide vision safety mask for over the spectacles or standard safety glasses, available at Sears Retail or Catalog stores.

HOW TO USE YOUR TRACTOR TO SET PARKING BRAKE (See Fig. 7)

- Depress clutch/brake pedal into full "BRAKE" position and hold.
- Place parking brake lever in "ENGAGED" position and release pressure from clutch/brake pedal. Pedal should remain in "BRAKE" position. Make sure parking brake will hold tractor secure.

NOTE: Under certain conditions when tractor is standing idle with the engine running, hot engine exhaust gases may cause "browning" of grass. To eliminate this possibility, always stop engine when stopping tractor on grass areas.



CAUTION: Always stop tractor completely, as described above, before leaving the operator's position; to empty grass catcher, etc.

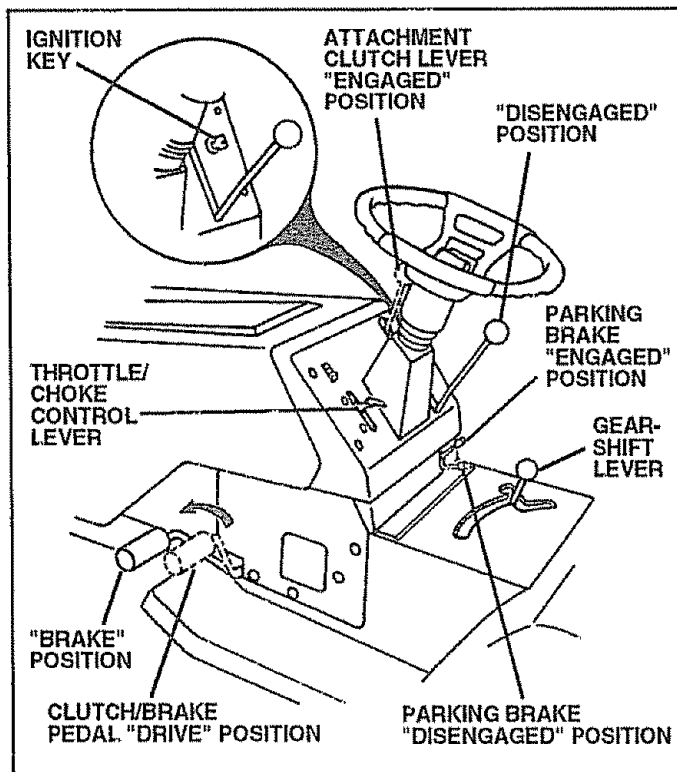

FIG. 7

STOPPING (See Fig. 7)

MOWER BLADES -

- Move attachment clutch lever to "DISENGAGED" position.

GROUND DRIVE -

- Depress clutch/brake pedal into full "BRAKE" position.
- Move gearshift lever to "NEUTRAL" position.

ENGINE -

- Move throttle control to "SLOW" position.

NOTE: Failure to move throttle control to "SLOW" position and allowing engine to idle before stopping may cause engine to "backfire".

- Turn ignition key to "OFF" position and remove key. Always remove key when leaving tractor to prevent unauthorized use.
- Never use choke to stop engine.

TO USE THROTTLE CONTROL (See Fig. 7)

Always operate engine at full throttle.

- Operating engine at less than full throttle reduces the battery charging rate.
- Full throttle offers the best bagging and mower performance.

TO MOVE FORWARD AND BACKWARD (See Fig. 6)

The direction and speed of movement is controlled by the gearshift lever.

- Start tractor with clutch/brake pedal depressed and gearshift lever in "NEUTRAL" position.
- Move gearshift lever to desired position.
- Slowly release clutch/brake pedal to start movement.

IMPORTANT: BRING TRACTOR TO A COMPLETE STOP BEFORE SHIFTING OR CHANGING GEARS. FAILURE TO DO SO WILL SHORTEN THE USEFUL LIFE OF YOUR TRANSAXLE.

TO ADJUST MOWER CUTTING HEIGHT (See Fig. 6)

The position of the attachment lift lever determines the cutting height.

- Grasp lift lever.
- Press plunger with thumb and move lever to desired position.

The cutting height range is approximately 1-1/2 to 4". The heights are measured from the ground to the blade tip with the engine not running. These heights are approximate and may vary depending upon soil conditions, height of grass and types of grass being mowed.

- The average lawn should be cut to approximately 2-1/2 inches during the cool season and over 3 inches during hot months. For healthier and better looking lawns, mow often and after moderate growth.
- For best cutting performance, grass over 6 inches in height should be mowed twice. Make the first cut relatively high; the second to desired height.

OPERATION

TO OPERATE MOWER (See Fig. 8)

Your tractor is equipped with an operator presence sensing switch. Any attempt by the operator to leave the seat with the engine running and the attachment clutch engaged will shut off the engine.

- Select desired height of cut.
- Engage mower by slowly moving attachment clutch lever to "ENGAGED" position.
- TO STOP MOWER - Move attachment clutch lever to "DISENGAGED" position.



CAUTION: Do not operate the mower without either the entire grass catcher, on mowers so equipped, or the discharge guard in place.

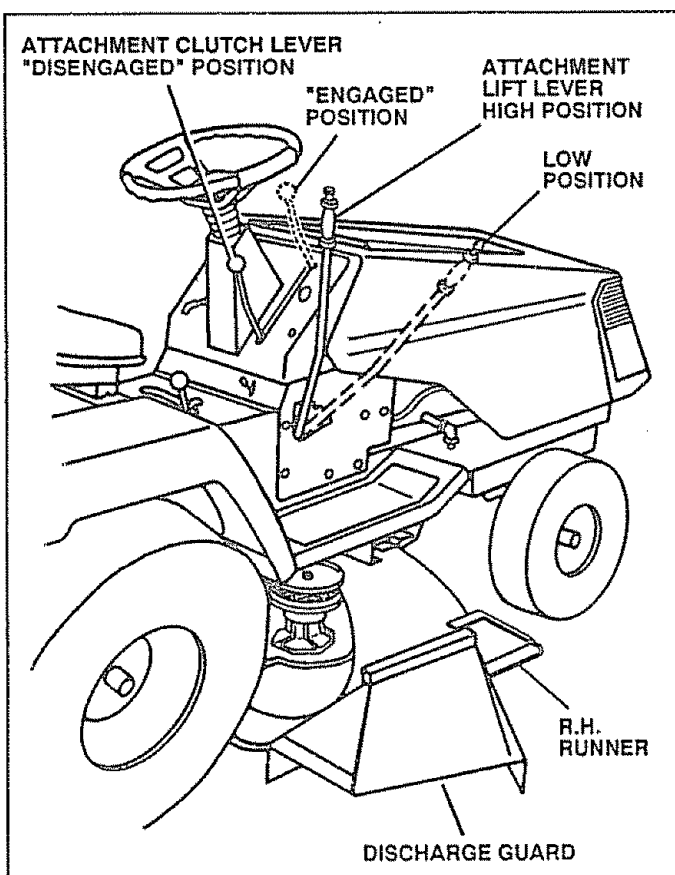

FIG. 8

TO OPERATE ON HILLS



CAUTION: Do not drive up or down hills with slopes greater than 15° and do not drive across any slope.

- Choose the slowest speed before starting up or down hills.
- Avoid stopping or changing speed on hills.
- If slowing is necessary, move throttle control lever to slower position.

- If stopping is absolutely necessary, push clutch/brake pedal quickly to brake position and engage parking brake.
- Move gearshift lever to 1st gear and be sure you have allowed room for tractor to roll slightly as you restart movement.
- To restart movement, slowly release parking brake and clutch/brake pedal.
- Make all turns slowly.

TO TRANSPORT

- Raise attachment lift control to highest position.
- When pushing or towing your tractor, be sure gearshift lever is in "NEUTRAL" position.
- Do not push or tow tractor at more than five (5) MPH.

BEFORE STARTING THE ENGINE

CHECK ENGINE OIL LEVEL (See Fig. 13)

- The engine in your tractor has been shipped from the factory already filled with summer weight oil.
- Check engine oil with tractor on level ground.
- Remove oil fill dipstick and wipe clean, replace and screw cap tight, wait for a few seconds, remove and read oil level. If necessary, add oil until "FULL" mark on dipstick is reached. Do not overfill.
- For cold weather operation you should change oil for easier starting (see "OIL VISCOSITY CHART" in the Customer Responsibilities section of this manual).
- To change engine oil, see the Customer Responsibilities section in this manual.

ADD GASOLINE

- Fill fuel tank. Use fresh, clean, regular unleaded gasoline. (Use of leaded gasoline will increase carbon and lead oxide deposits and reduce valve life).

IMPORTANT: WHEN OPERATING IN TEMPERATURES BELOW 32°F(0°C), USE FRESH, CLEAN WINTER GRADE GASOLINE TO HELP INSURE GOOD COLD WEATHER STARTING.

WARNING: Experience indicates that alcohol blended fuels (called gasohol or using ethanol or methanol) can attract moisture which leads to separation and formation of acids during storage. Acidic gas can damage the fuel system of an engine while in storage. To avoid engine problems, the fuel system should be emptied before storage of 30 days or longer. Drain the gas tank, start the engine and let it run until the fuel lines and carburetor are empty. Use fresh fuel next season. See Storage Instructions for additional information. Never use engine or carburetor cleaner products in the fuel tank or permanent damage may occur.



CAUTION: Fill to bottom of gas tank filler neck. Do not overfill. Wipe off any spilled oil or fuel. Do not store, spill or use gasoline near an open flame.

OPERATION

TO START ENGINE (See Fig. 7)

When starting engine for the first time or if engine has run out of fuel, it will take extra cranking time to move fuel from the tank to the engine.

- Depress the clutch/brake pedal and set the parking brake.
- Place gearshift lever in "NEUTRAL" position.
- Move attachment clutch to "DISENGAGED" position.
- Move throttle control lever to "CHOKE" position for cold engine start. For warm engine start, move throttle control to "FAST" position.
- Turn ignition key clockwise to "START" position and release key as soon as engine starts. Do not run starter continuously for more than fifteen seconds per minute. If engine does not start after several attempts, move throttle control to "FAST" position, wait a few minutes and try again.
- When engine starts, move throttle control to desired position.
- Allow engine to warm up for a few minutes before engaging drive or attachment clutch.

NOTE: If at a high altitude (above 3000 feet) or in cold temperatures (below 32° F), the carburetor fuel mixture may need to be adjusted for best engine performance. See "TO ADJUST CARBURETOR" in the Service and Adjustments section of this manual.

MOWING TIPS

- Tire chains cannot be used when the mower housing is attached to tractor.
- Mower should be properly leveled for best mowing performance. See "TO LEVEL MOWER HOUSING" in the Service and Adjustments section of this manual.
- Use the runner on the right hand side of mower as a guide. The blade cuts approximately an inch outside the runner (See Fig. 8).
- The left hand side of mower should be used for trimming.

- Drive so that clippings are discharged onto the area that has been cut. Have the cut area to the right of the tractor. This will result in a more even distribution of clippings and more uniform cutting.
- When mowing large areas, start by turning to the right so that clippings will discharge away from shrubs, fences, driveways, etc. After one or two rounds, mow in the opposite direction making left hand turns until finished (See Fig. 9).
- If grass is extremely tall, it should be mowed twice to reduce load and possible fire hazard from dried clippings. Make first cut relatively high; the second to the desired height.
- Do not mow grass when it is wet. Wet grass will plug mower and leave undesirable clumps. Allow grass to dry before mowing.
- Always operate engine at full throttle when mowing to assure better mowing performance and proper discharge of material. Regulate ground speed by selecting a low enough gear to give the mower cutting performance as well as the quality of cut desired.
- When operating attachments, select a ground speed that will suit the terrain and give best performance of the attachment being used.

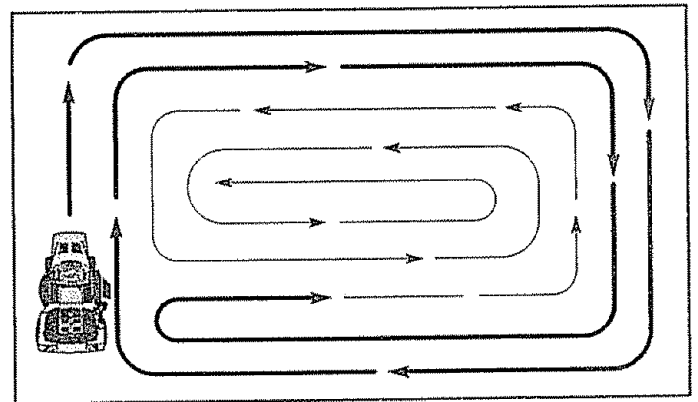

FIG. 9

CUSTOMER RESPONSIBILITIES

MAINTENANCE SCHEDULE		SERVICE DATES							
FILL IN DATES AS YOU COMPLETE REGULAR SERVICE		BEFORE EACH USE	FIRST 2 HOURS	EVERY 8 HOURS	EVERY 25 HOURS	EVERY 50 HOURS	EVERY 100 HOURS	BEFORE SEASON	BEFORE STORAGE
TRACTOR	Check Brake Operation	✓	✓						
	Check Tire Pressure	✓	✓						
	Check for Loose Fasteners	✓					✓		
	Sharpen/Replace Mower Blades			✓ ₄					
	Lubrication Chart			✓			✓		
	Check Battery Level/Recharge			✓					
	Clean Battery and Terminals			✓			✓		
	Check Transmission Cooling			✓					
	Adjust Blade Belt(s) Tension					✓ ₅			
	Adjust Motion Drive Belt(s) Tension					✓ ₅			
ENGINE	Check Engine Oil Level	✓	✓						
	Change Engine Oil		✓	✓ _{1,2,3}			✓		
	Clean Air Filter			✓ ₂					
	Clean Air Screen			✓ ₂					
	Inspect Muffler/Spark Arrester				✓				
	Replace Oil Filter (If equipped)					✓ _{1,2}			
	Clean Engine Cooling Fins					✓ ₂			
	Replace Spark Plug					✓	✓		
	Replace Air Filter Paper Cartridge					✓ ₂			
	Replace Fuel Filter						✓		

1 - Change more often when operating under a heavy load or in high ambient temperatures
 2 - Service more often when operating in dirty or dusty conditions

3 - If equipped with oil filter, change oil every 50 hours
 4 - Replace blades more often when mowing in sandy soil.
 5 - If equipped with adjustable system.

GENERAL RECOMMENDATIONS

The warranty on this tractor does not cover items that have been subjected to operator abuse or negligence. To receive full value from the warranty, operator must maintain tractor as instructed in this manual.

Some adjustments will need to be made periodically to properly maintain your tractor.

All adjustments in the Service and Adjustments section of this manual should be checked at least once each season.

- Once a year you should replace the spark plug, clean or replace air filter, and check blades and belts for wear. A new spark plug and clean air filter assure proper air-fuel mixture and help your engine run better and last longer.

BEFORE EACH USE

- Check engine oil level.
- Check brake operation.
- Check tire pressure.
- Check for loose fasteners.

LUBRICATION CHART

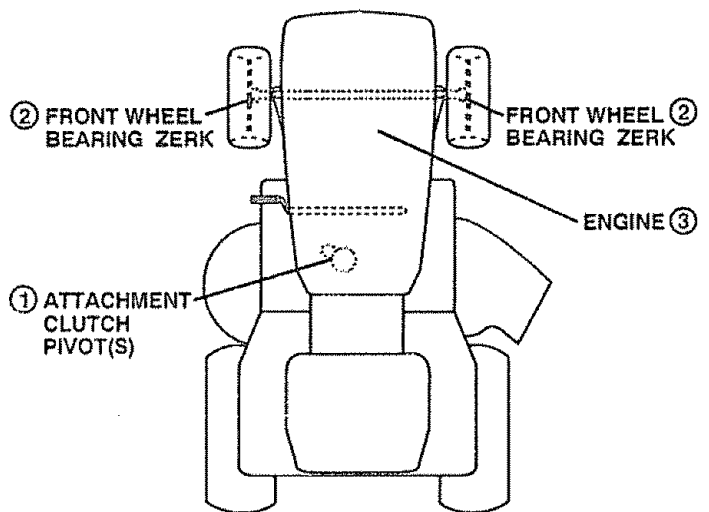

- ① SAE 30 OR 10W30 MOTOR OIL API - SG
- ② GENERAL PURPOSE GREASE
- ③ REFER TO CUSTOMER RESPONSIBILITIES "ENGINE" SECTION

IMPORTANT: DO NOT OIL OR GREASE THE PIVOT POINTS WHICH HAVE SPECIAL NYLON BEARINGS. VISCOUS LUBRICANTS WILL ATTRACT DUST AND DIRT THAT WILL SHORTEN THE LIFE OF THE SELF-LUBRICATING BEARINGS. IF YOU FEEL THEY MUST BE LUBRICATED, USE ONLY A DRY, POWDERED GRAPHITE TYPE LUBRICANT SPARINGLY.

CUSTOMER RESPONSIBILITIES

TRACTOR

Always observe safety rules when performing any maintenance.

BRAKE OPERATION

If tractor requires more than six (6) feet stopping distance at high speed in highest gear, than brake must be adjusted. (See "TO ADJUST BRAKE" in Service and Adjustments section of this manual).

TIRES

- Maintain proper air pressure in all tires (See "PRODUCT SPECIFICATIONS" on page 3 of this manual).
- Keep tires free of gasoline, oil, or insect control chemicals which can harm rubber.
- Avoid stumps, stones, deep ruts, sharp objects and other hazards that may cause tire damage.

BLADE CARE

For best results mower blades must be kept sharp. The blades can be sharpened with a file or on a grinding wheel. We suggest they be sharpened or replaced after every 25 hours of mowing. Check blades more often if mowing in sandy conditions.

- Do not attempt to sharpen blades while they are on the mower.
- Replace bent or damaged blades.

BLADE REMOVAL (See Fig. 10)

- Raise mower to highest position to allow access to blades.
- Remove hex bolt, lock washer and flat washer securing blade.
- Install new or resharpened blade with trailing edge up towards deck as shown.
- Reassemble hex bolt, lock washer and flat washer in exact order as shown.
- Tighten bolt securely (30-35 Ft. Lbs. torque).

IMPORTANT: BLADE BOLT IS GRADE 8 HEAT TREATED.

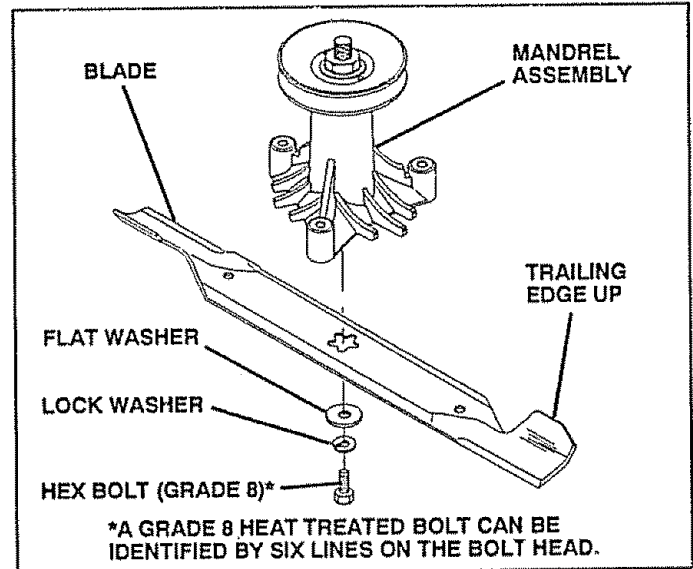

FIG. 10

TO SHARPEN BLADE (See Fig. 11)

Care should be taken to keep the blade balanced. An unbalanced blade will cause excessive vibration and eventual damage to mower and engine.

- The blade can be sharpened with a file or on a grinding wheel. Do not attempt to sharpen while on the mower.
- To check blade balance, you will need a 5/8" diameter steel bolt, pin, or a cone balancer. (When using a cone balancer, follow the instructions supplied with balancer).
- Slide blade on to an unthreaded portion of the steel bolt or pin and hold the bolt or pin parallel with the ground. If blade is balanced, it should remain in a horizontal position. If either end of the blade moves downward, sharpen the heavy end until the blade is balanced.

NOTE: Do not use a nail for balancing blade. The lobes of the center hole may appear to be centered, but are not.

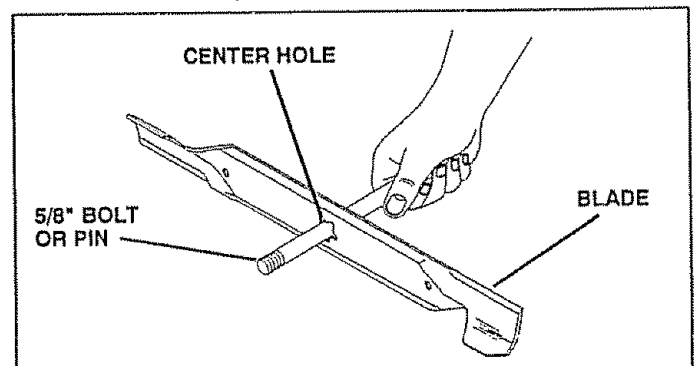

FIG. 11

CUSTOMER RESPONSIBILITIES

BATTERY (See Fig. 12)

Your unit has a battery charging system which is sufficient for normal use. However, periodic charging of the battery with an automotive charger will extend it's life.

- Acid solution level in each battery cell should be even with bottoms of vent wells. Add only distilled or iron free water if necessary. Do not overfill.
- Keep battery and terminals clean.
- Keep battery bolts tight.
- Keep vent caps tight and small vent holes in caps open.
- Recharge at 6 amperes for 1 hour.

TO CLEAN BATTERY AND TERMINALS -

Corrosion and dirt on the battery and terminals can cause the battery to "leak" power.

- Remove terminal guard.
- Disconnect BLACK battery cable first then RED battery cable and remove battery from tractor.
- Wash battery with solution of four tablespoons of baking soda to one gallon of water. Be careful not to get the soda solution into the cells.
- Rinse the battery with plain water and dry.
- Clean terminals and battery cable ends with wire brush until bright.
- Coat terminals with grease or petroleum jelly.
- Reinstall battery (See "INSTALL BATTERY" in the Assembly section of this manual).

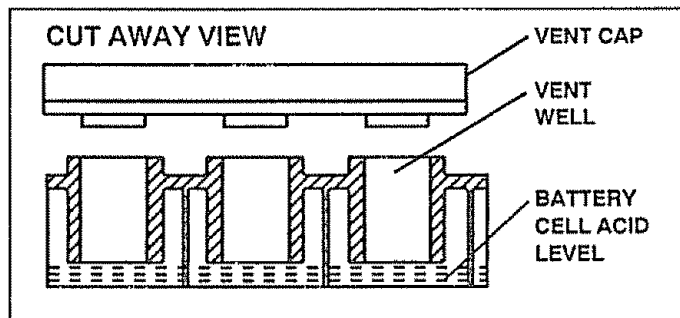

FIG. 12

V-BELTS

Check V-belts for deterioration and wear after 100 hours of operation and replace if necessary. The belts are not adjustable. Replace belts if they begin to slip from wear.

TRANSAXLE COOLING

Keep transaxle free from build-up of dirt and chaff which can restrict cooling.

ENGINE

LUBRICATION

Only use high quality detergent oil rated with API service classification SG. Select the oil's SAE viscosity grade according to your expected operating temperature.

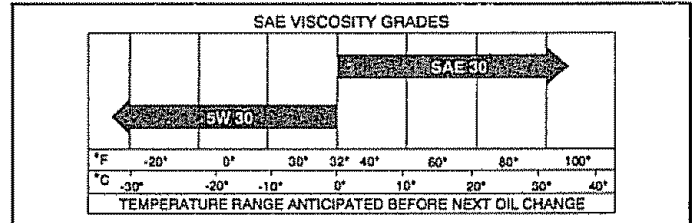

NOTE: Although multi-viscosity oils (5W30, 10W30, etc.) improve starting in cold weather, these multi-viscosity oils will result in increased oil consumption when used above 32°C. Check your engine oil level more frequently to avoid possible engine damage from running low on oil.

Change the oil after the first two hours of operation and every 25 hours thereafter or at least once a year if the tractor is not used for 25 hours in one year.

Check the crankcase oil level before starting the engine and after each eight (8) hours of continuous use. Tighten oil fill cap/dipstick securely each time you check the oil level.

TO CHANGE ENGINE OIL (See Fig. 13)

Determine temperature range expected before oil change. All oil must meet API service classification SG.

- Be sure tractor is on level surface.
- Oil will drain more freely when warm.
- Catch oil in a suitable container.
- Remove oil fill dipstick. Be careful not to allow dirt to enter the engine when changing oil.
- Remove drain plug.
- After oil has drained completely, replace oil drain plug and tighten securely.
- Refill engine with oil through oil fill dipstick tube. Pour slowly. Do not overfill. For approximate capacity see "PRODUCT SPECIFICATIONS" on page 3 of this manual.
- Use gauge on oil fill dipstick for checking level. Be sure dipstick cap is tightened securely for accurate reading. Keep oil at "FULL" line on dipstick.

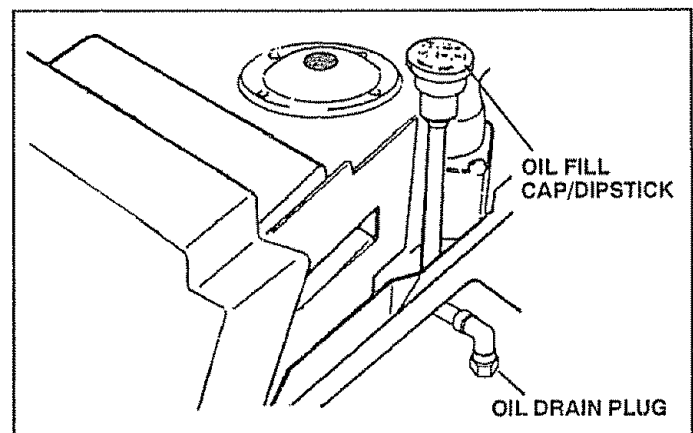

FIG. 13

CUSTOMER RESPONSIBILITIES

AIR FILTER FOAM PRE-CLEANER (See Fig. 14)

Your engine will not run properly and may be damaged by using a dirty air filter. Clean the foam pre-cleaner element after every 25 hours of operation, more often if used in very dusty, dirty conditions.

- Remove knob and cover.
- Remove cartridge nut and replace cartridge.
- Reassemble and tighten securely.

NOTE: Do not attempt to clean or oil the paper cartridge. Replace paper cartridge once a year or after every 100 hours of operation, more often if used in very dusty, dirty conditions.

- Wash foam pre-cleaner in liquid detergent and water.
- Wrap foam pre-cleaner in cloth and squeeze dry.
- Lightly coat foam pre-cleaner with clean engine oil. Squeeze in towel to remove excess oil. Do not saturate.
- Install foam pre-cleaner over paper cartridge.
- Reassemble cover and secure with knobs.

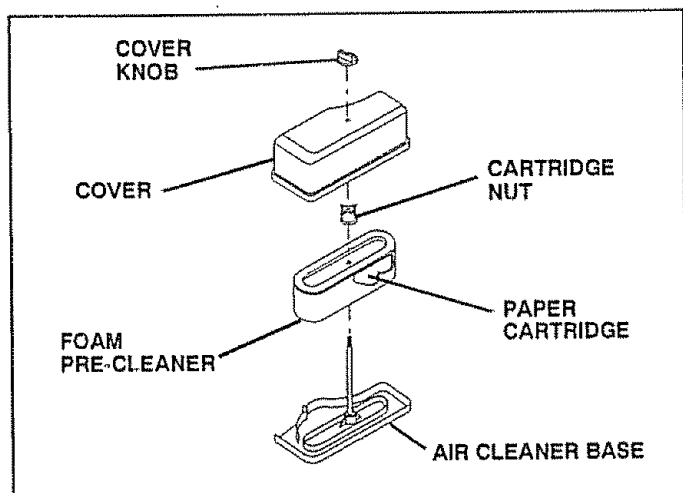

FIG. 14

AIR SCREEN (See Fig. 15)

The engine air screen must be kept free of dirt and chaff to prevent engine damage from overheating. Clean with a wire brush or compressed air to remove dirt and stubborn dried gum fibers.

ENGINE COOLING FINS (See Fig. 15)

Remove any dust, dirt or oil from engine cooling fins to prevent engine damage from overheating.

- Remove oil fill dipstick and cover opening to prevent entry of dirt.
- Remove screws from blower housing and lift housing off engine.
- Remove the screws securing the starter housing and lift housing off engine.
- Use compressed air or stiff bristle brush to thoroughly clean engine cooling fins.
- To reassemble, reverse above procedure.

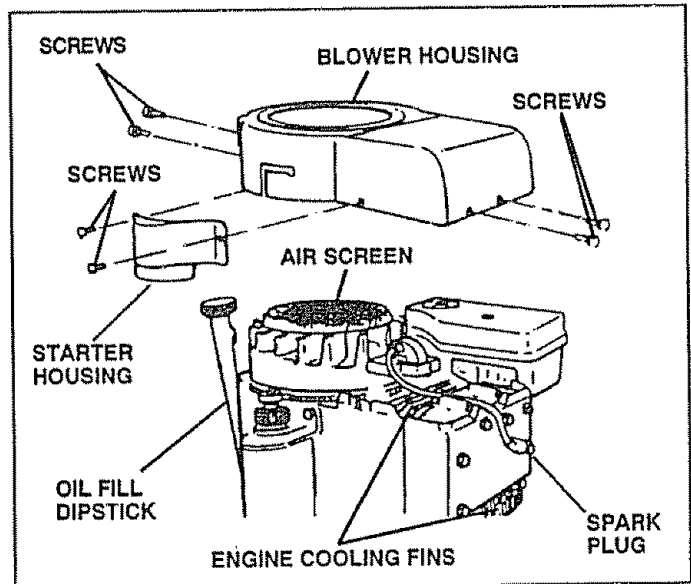

FIG. 15

MUFFLER

Inspect and replace corroded muffler and spark arrester (if equipped) as it could create a fire hazard and/or damage.

SPARK PLUGS

Replace spark plugs at the beginning of each mowing season or after every 100 hours of operation, whichever comes first. Spark plug type and gap setting are shown in "PRODUCT SPECIFICATIONS" on page 3 of this manual.

IN-LINE FUEL FILTER (See Fig. 16)

The fuel filter should be replaced once each season. If fuel filter becomes clogged, obstructing fuel flow to carburetor, replacement is required.

- With engine cool, remove filter and plug fuel line sections.
- Place new fuel filter in position in fuel line.
- Be sure there are no fuel line leaks and clamps are properly positioned.
- Immediately wipe up any spilled gasoline.

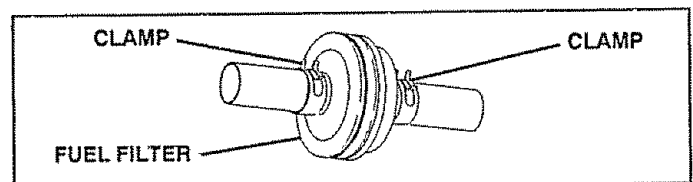

FIG. 16

CLEANING

- Clean engine, battery, seat, finish, etc. of all foreign matter.
- Keep finished surfaces and wheels free of all gasoline, oil, etc.
- Protect painted surfaces with automotive type wax.

We do not recommend using a garden hose to clean your tractor unless the electrical system, muffler, air filter and carburetor are covered to keep water out. Water in engine can result in a shortened engine life.

SERVICE AND ADJUSTMENTS

CAUTION: BEFORE PERFORMING ANY SERVICE OR ADJUSTMENTS:



- Depress clutch/brake pedal fully and set parking brake.
- Place gearshift lever in "NEUTRAL" position.
- Place attachment clutch in "DISENGAGED" position.
- Turn ignition key "OFF" and remove key.
- Make sure the blades and all moving parts have completely stopped.
- Disconnect spark plug wire from spark plug and place wire where it cannot come in contact with plug.

TRACTOR

TO REMOVE MOWER (See Fig. 17)

Mower will be easier to remove from the right side of tractor.

- Place attachment clutch in "DISENGAGED" position.
- Move attachment lift lever forward to lower mower to its lowest position.
- Roll belt off engine pulley.
- Disconnect clutch rod from clutch lever by removing retainer spring.
- Disconnect suspension arms from rear deck brackets by removing retainer springs.
- Disconnect front links from deck by removing retainer springs.
- Raise lift lever to raise suspension arms. Slide mower out from under tractor.

IMPORTANT: IF AN ATTACHMENT OTHER THAN THE MOWER IS TO BE MOUNTED TO THE TRACTOR, THE R.H. AND L.H. SUSPENSION ARMS MUST BE REMOVED FROM TRACTOR.

TO INSTALL MOWER (See Fig. 17)

- Raise attachment lift lever to its highest position.
- Slide mower under tractor with discharge guard to right side of tractor.
- Lower lift lever to its lowest position.
- Install mower in reverse order of removal instructions.

NOTE: The mower clutch rod has a trunnion that has been preset at the factory for optimum mower performance. **DO NOT MOVE THE TRUNNION ON THE CLUTCH ROD.** If for any reason the trunnion has been moved on the clutch rod, it must be reset to correct position (parallel with clutch rod) and measure 10-11/32" (Check dimension on edge of flat work surface as shown).

Be sure to tighten trunnion nut securely against trunnion after making any adjustments.

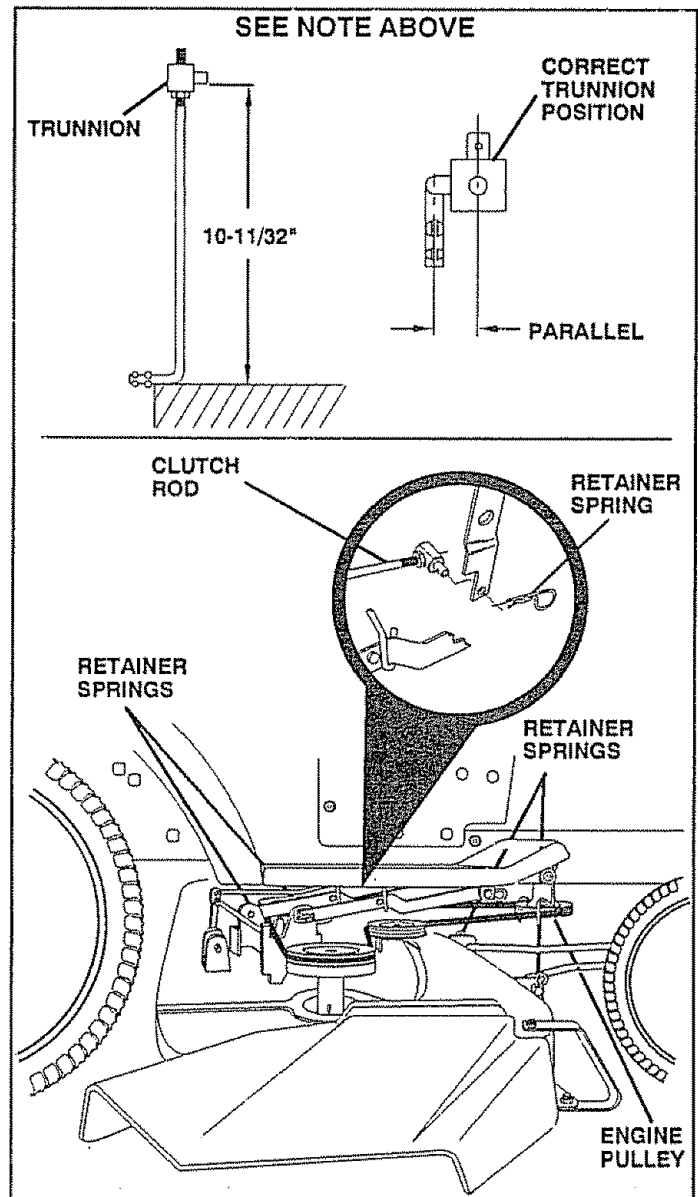

FIG. 17

SERVICE AND ADJUSTMENTS

TO LEVEL MOWER HOUSING

Adjust the mower while tractor is parked on level ground or driveway. Make sure tires are properly inflated (See "PRODUCT SPECIFICATIONS" on page 3). If tires are over or under inflated, you will not properly adjust your mower.

SIDE-TO-SIDE ADJUSTMENT (See Figs. 18 and 19) -

You will need two (2) standard 2 x 4 short pieces of wood to make the following adjustment. Similar blocks measuring 1-1/2" thick may also be used.

- Raise mower with attachment lift control to allow two (2) 1-1/2" thick blocks to be placed under rear edge of mower directly behind mandrels.
- Lower mower deck to its lowest height of cut position (See "TO ADJUST MOWER CUTTING HEIGHT" in Operation section of this manual).
- On both sides of tractor, loosen, but do not remove, the fasteners securing the adjustable pivot brackets to frame. Both brackets must be loose enough to move freely.
- Pull down firmly on suspension arm to remove any slack in pivot bracket and hold while tightening rear fastener first to secure. Tighten remaining fastener.
- Repeat procedure on other side of tractor.
- Raise mower with attachment lift control and remove blocks from under mower.

PLACE TWO (2) 1-1/2" THICK BLOCKS UNDER REAR EDGE OF DECK (Use wood 2 x 4's or equivalent)

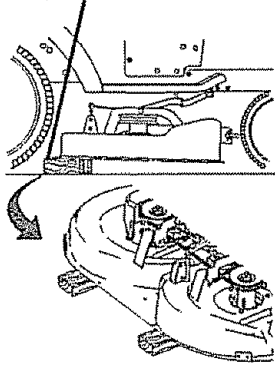

MOWER MUST BE IN LOWEST HEIGHT OF CUT POSITION

FIG. 18

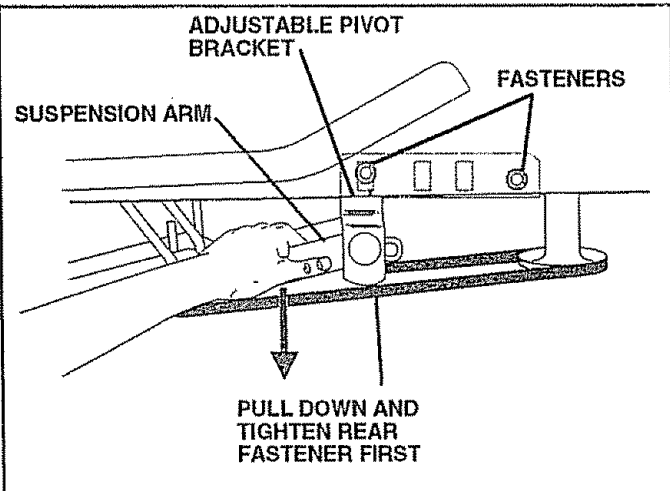

FIG. 19

FRONT-TO-BACK ADJUSTMENT (See Figs. 20 and 21) - **IMPORTANT:** DECK MUST BE LEVEL SIDE-TO-SIDE. IF THE FOLLOWING FRONT-TO-BACK ADJUSTMENT IS NECESSARY, BE SURE TO ADJUST BOTH FRONT LINKS EQUALLY SO MOWER WILL STAY LEVEL SIDE-TO-SIDE.

To obtain the best cutting results, the mower housing should be adjusted so that the front is approximately 1/4" to 3/4" lower than the rear when the mower is in its highest position.

Check adjustment on right side of tractor. Measure distance "D" directly in front and behind the mandrel at bottom edge of mower housing as shown.

- Before making any necessary adjustments, check that both front links are equal in length. Both links should be approximately 10-3/8".
- If links are not equal in length, adjust one link to same length as other link.
- To lower front of mower loosen nut "E" on both front links an equal number of turns.
- When distance "D" is 1/4" to 3/4" lower at front than rear, tighten nuts "F" against trunnion on both front links.
- To raise front of mower, loosen nut "F" from trunnion on both front links. Tighten nut "E" on both front links an equal number of turns.
- When distance "D" is 1/4" to 3/4" lower at front than rear, tighten nut "F" against trunnion on both front links.
- Recheck side-to-side adjustment.

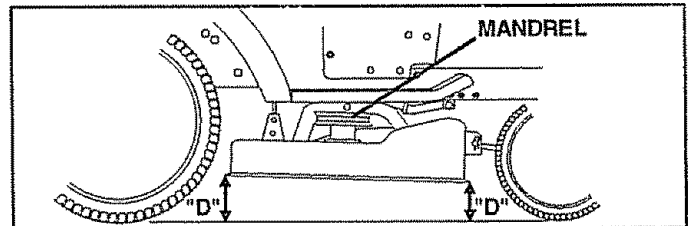

FIG. 20

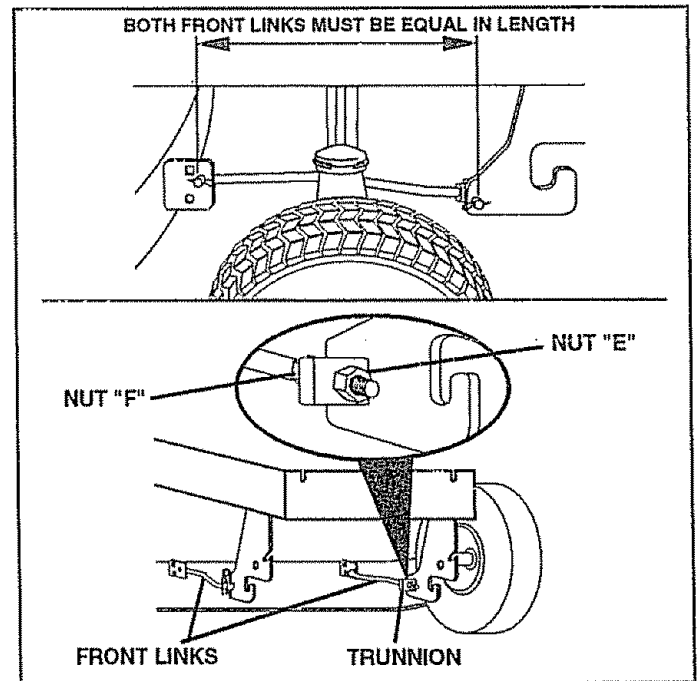

FIG. 21

SERVICE AND ADJUSTMENTS

TO REPLACE MOWER BLADE DRIVE BELT (See Fig. 22)

The mower blade drive belt may be replaced without tools. Park the tractor on level surface. Engage parking brake. For assistance, there is a belt installation guide decal on the mower housing.

BELT REMOVAL -

- Place attachment clutch in "DISENGAGED" position.
- Move attachment lift lever forward to lower mower to its lowest position.
- Roll belt off engine pulley.
- Disconnect R.H. suspension arm from rear deck bracket by removing retainer spring.
- Work belt off both mandrel pulleys and idler pulleys.
- Pull belt away from mower.

BELT INSTALLATION -

- Install new belt in reverse order of removal.
- Make sure belt is in all pulley grooves and inside all belt guides.

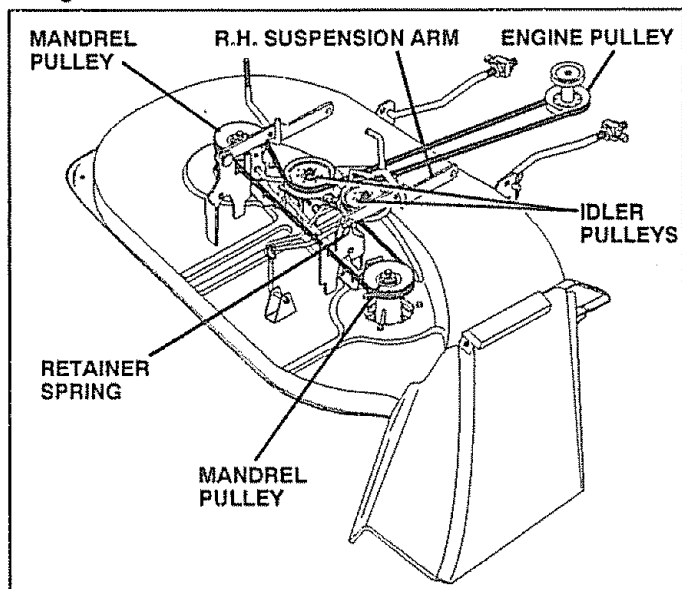

FIG. 22

TO ADJUST BRAKE (See Fig. 23)

Your tractor is equipped with an adjustable brake system which is mounted on the right side of the transaxle.

If tractor requires more than six (6) feet stopping distance at high speed in highest gear, then brake must be adjusted.

- Depress clutch/brake pedal and engage parking brake.
- Measure distance between brake operating arm and nut "A" on brake rod.
- If distance is other than 1-1/2", disengage parking brake, loosen jam nut and turn nut "A" until distance becomes 1-1/2". Retighten jam nut against nut "A".
- Engage parking brake and recheck distance.
- Road test tractor for proper stopping distance as stated above. Readjust if necessary. If stopping distance is still greater than six (6) feet in highest gear, further maintenance is necessary. Contact your nearest authorized service center.

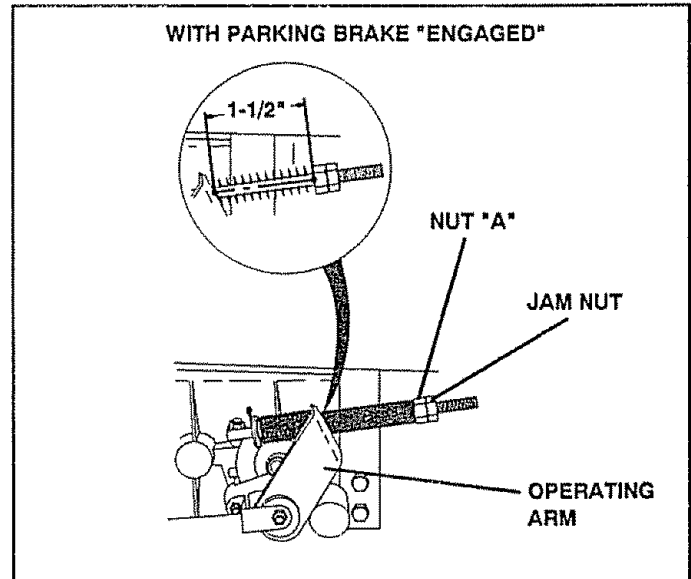

FIG. 23

TO REPLACE MOTION DRIVE BELT (See Fig. 24)

Park the tractor on level area. Engage parking brake. For assistance, there is a belt installation guide decal on bottom side of left footrest.

- Remove mower (See "TO REMOVE MOWER" in this section of this manual).
- Remove belt from stationary idler and clutching idler.
- Remove belt from engine pulley.
- Roll belt over top of transaxle pulley.
- Install new belt by reversing above procedure.

IMPORTANT: REPLACE ONLY WITH BELT LISTED IN THIS MANUAL.

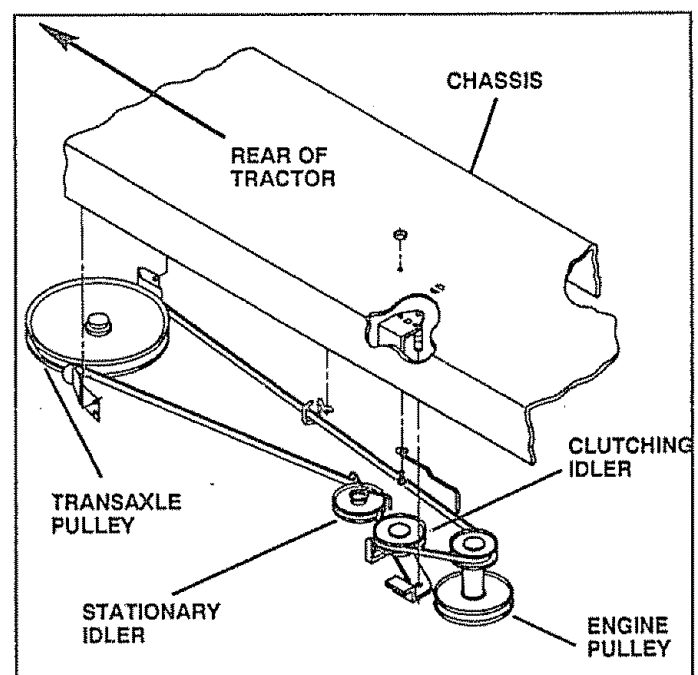

FIG. 24

SERVICE AND ADJUSTMENTS

TO ADJUST STEERING WHEEL ALIGNMENT

If steering wheel crossbars are not horizontal (left to right) when wheels are positioned straight forward, remove steering wheel and reassemble per instructions in the Assembly section of this manual.

FRONT WHEEL TOE-IN/CAMBER

The front wheel toe-in and camber are not adjustable on your tractor. If damage has occurred to affect the front wheel toe-in or camber, contact your nearest authorized service center.

TO REMOVE WHEEL FOR REPAIRS (See Fig. 25)

- Block up axle securely.
- Remove axle cover, retaining ring and washers to allow wheel removal (rear wheel contains a square key - Do not lose).
- Repair tire and reassemble.
- On rear wheels only: align grooves in rear wheel hub and axle. Insert square key.
- Replace washers and snap retaining ring securely in axle groove.
- Replace axle cover.

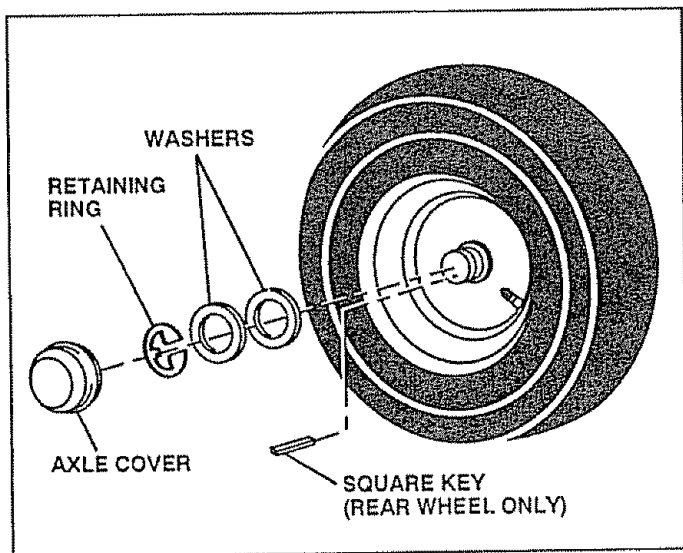

FIG. 25

TO START ENGINE WITH A WEAK BATTERY (See Fig. 26)



CAUTION: Lead-acid batteries generate explosive gases. Keep sparks, flame and smoking materials away from batteries. Always wear eye protection when around batteries.

If your battery is too weak to start the engine, it should be recharged. If "jumper cables" are used for emergency starting, follow this procedure:

IMPORTANT: YOUR TRACTOR IS EQUIPPED WITH A 12 VOLT NEGATIVE GROUNDED SYSTEM. THE OTHER VEHICLE MUST ALSO BE A 12 VOLT NEGATIVE GROUNDED SYSTEM. DO NOT USE YOUR TRACTOR BATTERY TO START OTHER VEHICLES.

TO ATTACH JUMPER CABLES -

- Connect each end of the RED cable to the POSITIVE (+) terminal of each battery, taking care not to short against chassis
- Connect one end of the BLACK cable to the NEGATIVE (-) terminal of fully charged battery.
- Connect the other end of the BLACK cable to a good CHASSIS GROUND, away from fuel tank and battery.

TO REMOVE CABLES, REVERSE ORDER -

- BLACK cable first from chassis and fully charged battery
- RED cable last from both batteries.

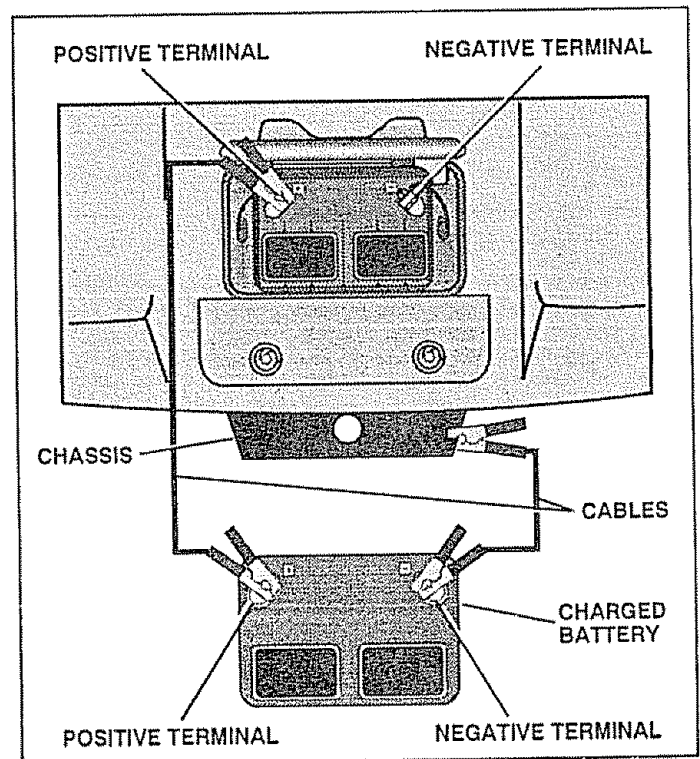

FIG. 26

SERVICE AND ADJUSTMENTS

TO REPLACE FUSE (See Fig. 27)

Replace with 30 amp automotive-type plug-in fuse. The fuse holder is located in the engine compartment, directly in front of the dash.

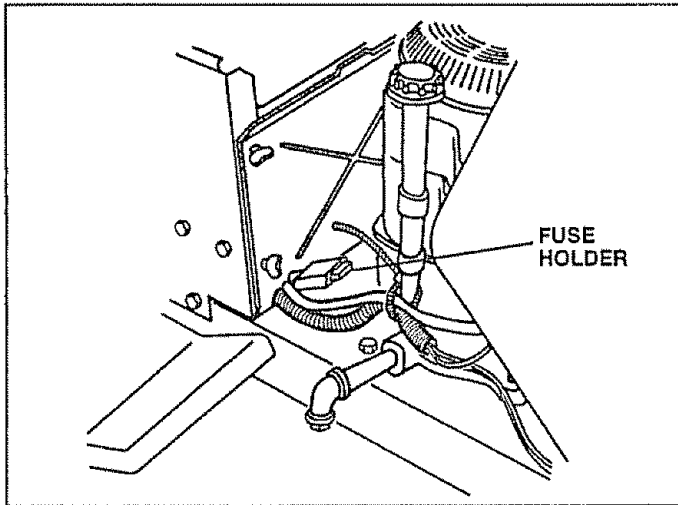

FIG. 27

TO REPLACE HEADLIGHT BULB

- Raise hood.
- Pull bulb holder out of the hole in the backside of the grill.
- Replace bulb in holder and push bulb holder securely back into the hole in the backside of the grill.
- Close hood.

INTERLOCKS AND RELAYS

Loose or damaged wiring may cause your tractor to run poorly, stop running or prevent it from starting.

- Check wiring. See the electrical wiring diagram in the Repair Parts section of this manual.

TO REMOVE HOOD AND GRILL (See Fig. 28)



CAUTION: Muffler is hot. Be careful when removing retainer springs from hood pivot brackets.

- Raise hood.
- Unsnap headlight wire connector.
- Remove retainer springs from hood pivot brackets.
- Stand in front of tractor. Grasp hood at sides, tilt forward and lift off of tractor.
- To reinstall, slide hood pivot brackets into slots in frame. Replace retainer springs.
- Reconnect headlight wire connector and close hood.

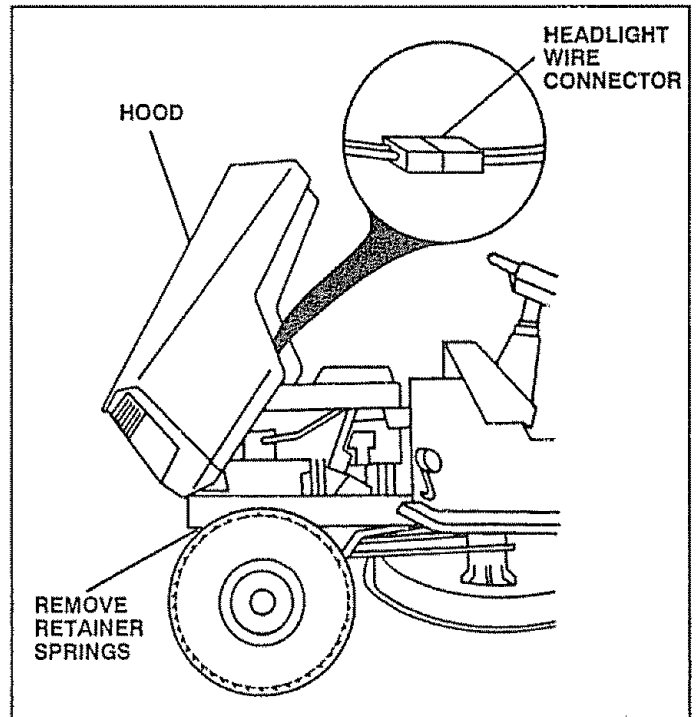

FIG. 28

SERVICE AND ADJUSTMENTS

ENGINE

TO ADJUST THROTTLE CONTROL CABLE (See Fig. 29)

The throttle control has been preset at the factory and adjustment should not be necessary. Check adjustment as described below before loosening cable. If adjustment is necessary, proceed as follows:

- With engine not running, move throttle control lever from "SLOW" to "CHOKE" position. Slowly move lever from "CHOKE" to "FAST" position.
- Check that holes "A" in governor control lever and hole in governor plate line-up. If holes "A" are not aligned, loosen clamp screw and move throttle cable until holes are aligned. Tighten clamp screw securely.

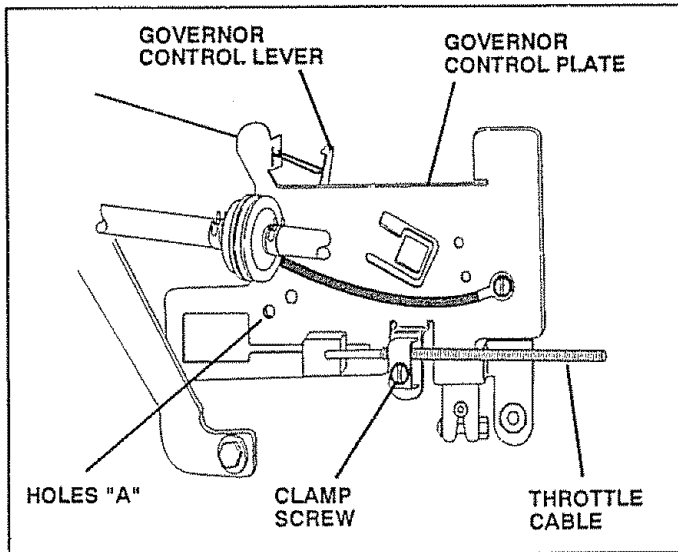

FIG. 29

TO ADJUST CARBURETOR (See Fig. 30)

The carburetor has been preset at the factory and adjustment should not be necessary. However, minor adjustment may be required to compensate for differences in fuel, temperature, altitude or load. If the carburetor does need adjustment, proceed as follows:

In general, turning idle mixture valve in (clockwise) decreases the supply of fuel to the engine giving a leaner fuel/air mixture. Turning the idle mixture valve out (counterclockwise) increases the supply of fuel to the engine giving a richer fuel/air mixture.

IMPORTANT: DAMAGE TO THE NEEDLE VALVE AND THE SEAT IN CARBURETOR MAY RESULT IF SCREW IS TURNED IN TOO TIGHT.

PRELIMINARY SETTING -

- Air cleaner assembly must be assembled to the carburetor when making carburetor adjustments.
- Be sure the throttle control cable is adjusted properly (see above).
- With engine off turn idle mixture valve in (clockwise) closing it finger tight and then turn out (counterclockwise) 1 full turn.

FINAL SETTING -

- Start engine and allow to warm for five minutes. Make final adjustments with engine running and shift/motion control lever in "NEUTRAL" position.
- Move throttle control lever to "SLOW" position. With finger, rotate and hold throttle lever against idle speed screw. Turn idle speed screw to attain 1750 RPM.
- While still holding throttle lever against idle speed screw, turn idle mixture valve in (clockwise) until engine begins to die and then turn out (counterclockwise) until engine runs rough. Turn valve to a point midway between those two positions. Release throttle lever.

ACCELERATION TEST -

- Move throttle control lever from "SLOW" to "FAST" position. If engine hesitates or dies, turn idle mixture valve out (counterclockwise) 1/8 turn. Repeat test and continue to adjust, if necessary, until engine accelerates smoothly.

High speed stop is factory adjusted. Do not adjust - damage may result.

IMPORTANT: NEVER TAMPER WITH THE ENGINE GOVERNOR, WHICH IS FACTORY SET FOR PROPER ENGINE SPEED. OVERSPEEDING THE ENGINE ABOVE THE FACTORY HIGH SPEED SETTING CAN BE DANGEROUS. IF YOU THINK THE ENGINE-GOVERNED HIGH SPEED NEEDS ADJUSTING, CONTACT YOUR NEAREST AUTHORIZED SERVICE CENTER, WHICH HAS PROPER EQUIPMENT AND EXPERIENCE TO MAKE ANY NECESSARY ADJUSTMENTS.

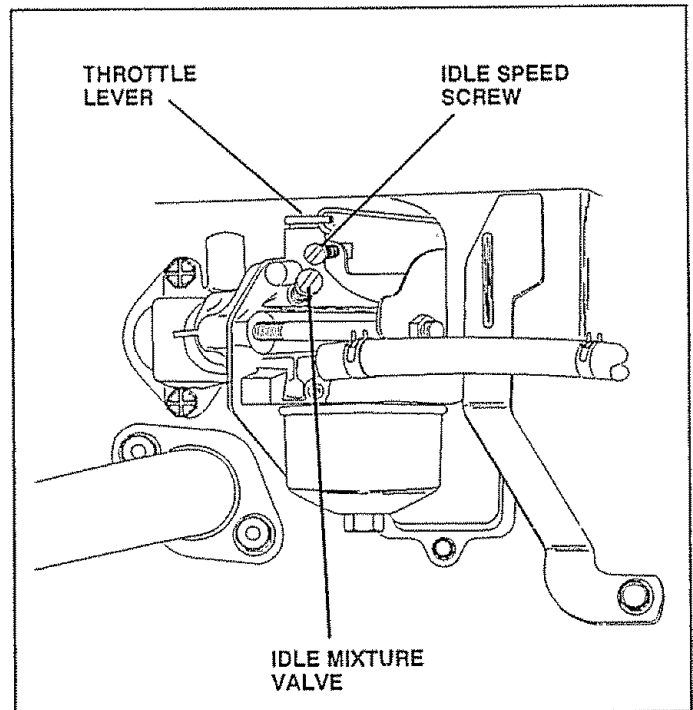

FIG. 30

STORAGE

Immediately prepare your tractor for storage at the end of the season or if the tractor will not be used for 30 days or more.



CAUTION: Never store the tractor with gasoline in the tank inside a building where fumes may reach an open flame or spark. Allow the engine to cool before storing in any enclosure.

TRACTOR

Remove mower from tractor for winter storage. When mower is to be stored for a period of time, clean it thoroughly, remove all dirt, grease, leaves, etc. Store in a clean, dry area.

- Clean entire tractor (See "CLEANING" in the Customer Responsibilities section of this manual).
- Inspect and replace belts, if necessary (See belt replacement instructions in the Service and Adjustments section of this manual).
- Lubricate as shown in the Customer Responsibilities section of this manual.
- Be sure that all nuts, bolts and screws are securely fastened. Inspect moving parts for damage, breakage and wear. Replace if necessary.
- Touch up all rusted or chipped paint surfaces; sand lightly before painting.

BATTERY

- Fully charge the battery for storage.
- After a period of time in storage, battery may require recharging.
- To help prevent corrosion and power leakage during long periods of storage, battery cables should be disconnected and battery cleaned thoroughly (see "TO CLEAN BATTERY AND TERMINALS" in the Customer Responsibilities section of this manual).
- After cleaning, leave cables disconnected and place cables where they cannot come in contact with battery terminals.
- Be sure battery drain tube is securely attached.

ENGINE

FUEL SYSTEM

IMPORTANT: IT IS IMPORTANT TO PREVENT GUM DEPOSITS FROM FORMING IN ESSENTIAL FUEL SYSTEM PARTS SUCH AS CARBURETOR, FUEL FILTER, FUEL HOSE, OR TANK DURING STORAGE. ALSO, EXPERIENCE INDICATES THAT ALCOHOL BLENDED FUELS (CALLED GASOHOL OR USING ETHANOL OR METHANOL) CAN ATTRACT MOISTURE WHICH LEADS TO SEPARATION AND FORMATION OF ACIDS DURING STORAGE. ACIDIC GAS CAN DAMAGE THE FUEL SYSTEM OF AN ENGINE WHILE IN STORAGE.

- Drain the fuel tank.
- Start the engine and let it run until the fuel lines and carburetor are empty.
- Never use engine or carburetor cleaner products in the fuel tank or permanent damage may occur.
- Use fresh fuel next season.

NOTE: Fuel stabilizer is an acceptable alternative in minimizing the formation of fuel gum deposits during storage. Add stabilizer to gasoline in fuel tank or storage container. Always follow the mix ratio found on stabilizer container. Run engine at least 10 minutes after adding stabilizer to allow the stabilizer to reach the carburetor. Do not drain the gas tank and carburetor if using fuel stabilizer.

ENGINE OIL

Drain oil (with engine warm) and replace with clean engine oil. (See "ENGINE" in the Customer Responsibilities section of this manual).

CYLINDERS

- Remove spark plug(s).
- Pour one ounce of oil through spark plug hole(s) into cylinder(s).
- Turn ignition key to "START" position for a few seconds to distribute oil.
- Replace with new spark plug(s).

OTHER

- Do not store gasoline from one season to another.
- Replace your gasoline can if your can starts to rust. Rust and/or dirt in your gasoline will cause problems.
- If possible, store your tractor indoors and cover it to give protection from dust and dirt.
- Cover your tractor with a suitable protective cover that does not retain moisture. Do not use plastic. Plastic cannot breathe which allows condensation to form and will cause your tractor to rust.

IMPORTANT: NEVER COVER TRACTOR WHILE ENGINE AND EXHAUST AREAS ARE STILL WARM.

TROUBLESHOOTING POINTS

PROBLEM	CAUSE	CORRECTION
Will not start	<ol style="list-style-type: none"> 1. Out of fuel. 2. Engine not "CHOKED" properly. 3. Engine flooded. 4. Bad spark plug. 5. Dirty air filter. 6. Dirty fuel filter. 7. Water in fuel. 8. Loose or damaged wiring. 9. Carburetor out of adjustment. 10. Engine valves out of adjustment. 	<ol style="list-style-type: none"> 1. Fill fuel tank. 2. See "TO START ENGINE" in Operation section. 3. Wait several minutes before attempting to start. 4. Replace spark plug. 5. Clean/replace air filter. 6. Replace fuel filter. 7. Drain fuel tank and carburetor, refill tank with fresh gasoline and replace fuel filter. 8. Check all wiring. 9. Contact Sears Service Center/Department. 10. Contact Sears Service Center/Department.
Hard to start	<ol style="list-style-type: none"> 1. Dirty air filter. 2. Bad spark plug. 3. Weak or dead battery. 4. Dirty fuel filter. 5. Stale or dirty fuel. 6. Loose or damaged wiring. 7. Carburetor out of adjustment. 8. Engine valves out of adjustment. 	<ol style="list-style-type: none"> 1. Clean/replace air filter. 2. Replace spark plug. 3. Recharge or replace battery. 4. Replace fuel filter. 5. Drain fuel tank and refill with fresh gasoline. 6. Check all wiring. 7. Contact Sears Service Center/Department. 8. Contact Sears Service Center/Department.
Engine will not turn over	<ol style="list-style-type: none"> 1. Clutch/brake pedal not depressed 2. Attachment clutch is engaged. 3. Weak or dead battery. 4. Blown fuse. 5. Corroded battery terminals. 6. Loose or damaged wiring. 7. Faulty ignition switch. 8. Faulty solenoid or starter. 9. Faulty operator presence switch(es). 	<ol style="list-style-type: none"> 1. Depress clutch/brake pedal. 2. Disengage attachment clutch. 3. Recharge or replace battery. 4. Replace fuse. 5. Clean battery terminals. 6. Check all wiring. 7. Check/replace ignition switch. 8. Check/replace solenoid or starter. 9. Contact Sears Service Center/Department.
Engine clicks but will not start	<ol style="list-style-type: none"> 1. Weak or dead battery. 2. Corroded battery terminals. 3. Loose or damaged wiring. 4. Faulty solenoid or starter. 	<ol style="list-style-type: none"> 1. Recharge or replace battery. 2. Clean battery terminals. 3. Check all wiring. 4. Check/replace solenoid or starter.
Loss of power	<ol style="list-style-type: none"> 1. Cutting too much grass/too fast. 2. Throttle in "CHOKE" position. 3. Build-up of grass, leaves and trash under mower. 4. Dirty air filter. 5. Low oil level/dirty oil. 6. Faulty spark plug. 7. Dirty fuel filter. 8. Stale or dirty fuel. 9. Water in fuel. 10. Spark plug wire loose. 11. Dirty engine air screen/fins. 12. Dirty/clogged muffler. 13. Loose or damaged wiring. 14. Carburetor out of adjustment. 15. Engine valves out of adjustment. 	<ol style="list-style-type: none"> 1. Set in "Higher Cut" position/reduce speed. 2. Adjust throttle control. 3. Clean underside of mower housing. 4. Clean/replace air filter. 5. Check oil level/change oil. 6. Clean and regap or change spark plug. 7. Replace fuel filter. 8. Drain fuel tank and refill with fresh gasoline. 9. Drain fuel tank and carburetor, refill tank with fresh gasoline and replace fuel filter. 10. Connect and tighten spark plug wire. 11. Clean engine air screen/fins. 12. Clean/replace muffler. 13. Check all wiring. 14. Contact Sears Service Center/Department. 15. Contact Sears Service Center/Department.
Excessive vibration	<ol style="list-style-type: none"> 1. Worn, bent or loose blade. 2. Bent blade mandrel. 3. Loose/damaged part(s). 	<ol style="list-style-type: none"> 1. Replace blade. Tighten blade bolt. 2. Replace blade mandrel. 3. Tighten loose part(s). Replace damaged parts.

TROUBLESHOOTING POINTS

PROBLEM	CAUSE	CORRECTION
Engine continues to run when operator leaves seat with attachment clutch engaged	<ol style="list-style-type: none"> 1. Faulty operator-safety presence control system. 	<ol style="list-style-type: none"> 1. Check wiring, switches and connections. If not corrected, contact Sears Service Center/Department.
Poor cut - uneven	<ol style="list-style-type: none"> 1. Worn, bent or loose blade. 2. Mower deck not level. 3. Buildup of grass, leaves, and trash under mower. 4. Bent blade mandrel. 5. Clogged mower deck vent holes from buildup of grass, leaves, and trash around mandrels. 	<ol style="list-style-type: none"> 1. Replace blade. Tighten blade bolt. 2. Level mower deck. 3. Clean underside of mower housing. 4. Replace blade mandrel. 5. Clean around mandrels to open vent holes.
Mower blades will not rotate	<ol style="list-style-type: none"> 1. Obstruction in clutch mechanism. 2. Worn/damaged mower drive belt. 3. Frozen idler pulley. 4. Frozen blade mandrel. 	<ol style="list-style-type: none"> 1. Remove obstruction. 2. Replace mower drive belt. 3. Replace idler pulley. 4. Replace blade mandrel.
Poor grass discharge	<ol style="list-style-type: none"> 1. Engine speed too slow. 2. Travel speed too fast. 3. Wet grass 4. Mower deck not level 5. Low/uneven tire air pressure. 6. Worn, bent or loose blade. 7. Buildup of grass, leaves and trash under mower. 8. Mower drive belt worn. 9. Blades improperly installed. 10. Improper blades used. 11. Clogged mower deck vent holes from buildup of grass, leaves, and trash around mandrels. 	<ol style="list-style-type: none"> 1. Place throttle control in "FAST" position. 2. Shift to slower speed. 3. Allow grass to dry before mowing. 4. Level mower deck. 5. Check tires for proper air pressure. 6. Replace/sharpen blade. Tighten blade bolt. 7. Clean underside of mower housing. 8. Replace mower drive belt. 9. Reinstall blades sharp edge down. 10. Replace with blades listed in this manual. 11. Clean around mandrels to open vent holes.
Headlight(s) not working (if so equipped)	<ol style="list-style-type: none"> 1. Switch is "OFF". 2. Bulb(s) burned out. 3. Faulty light switch. 4. Loose or damaged wiring. 5. Blown fuse. 	<ol style="list-style-type: none"> 1. Turn switch "ON". 2. Replace bulb(s). 3. Check/replace light switch. 4. Check wiring and connections. 5. Replace fuse.
Battery will not charge	<ol style="list-style-type: none"> 1. Bad battery cell(s) 2. Poor cable connections. 3. Faulty regulator (if so equipped). 4. Faulty alternator 	<ol style="list-style-type: none"> 1. Replace battery. 2. Check/clean all connections. 3. Replace regulator. 4. Replace alternator.
Engine "backfires" when turning engine "OFF"	<ol style="list-style-type: none"> 1. Engine throttle control not set at "SLOW" position for 30 seconds before stopping engine. 	<ol style="list-style-type: none"> 1. Move throttle control to "SLOW" position and allow to idle for 30 seconds before stopping engine.

12 HP 38" TRACTOR - - MODEL NUMBER 917.255561

SCHEMATIC

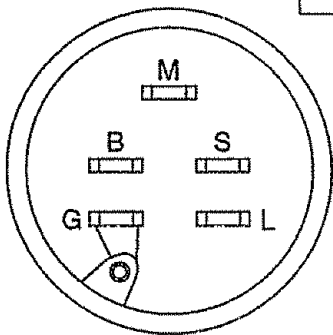
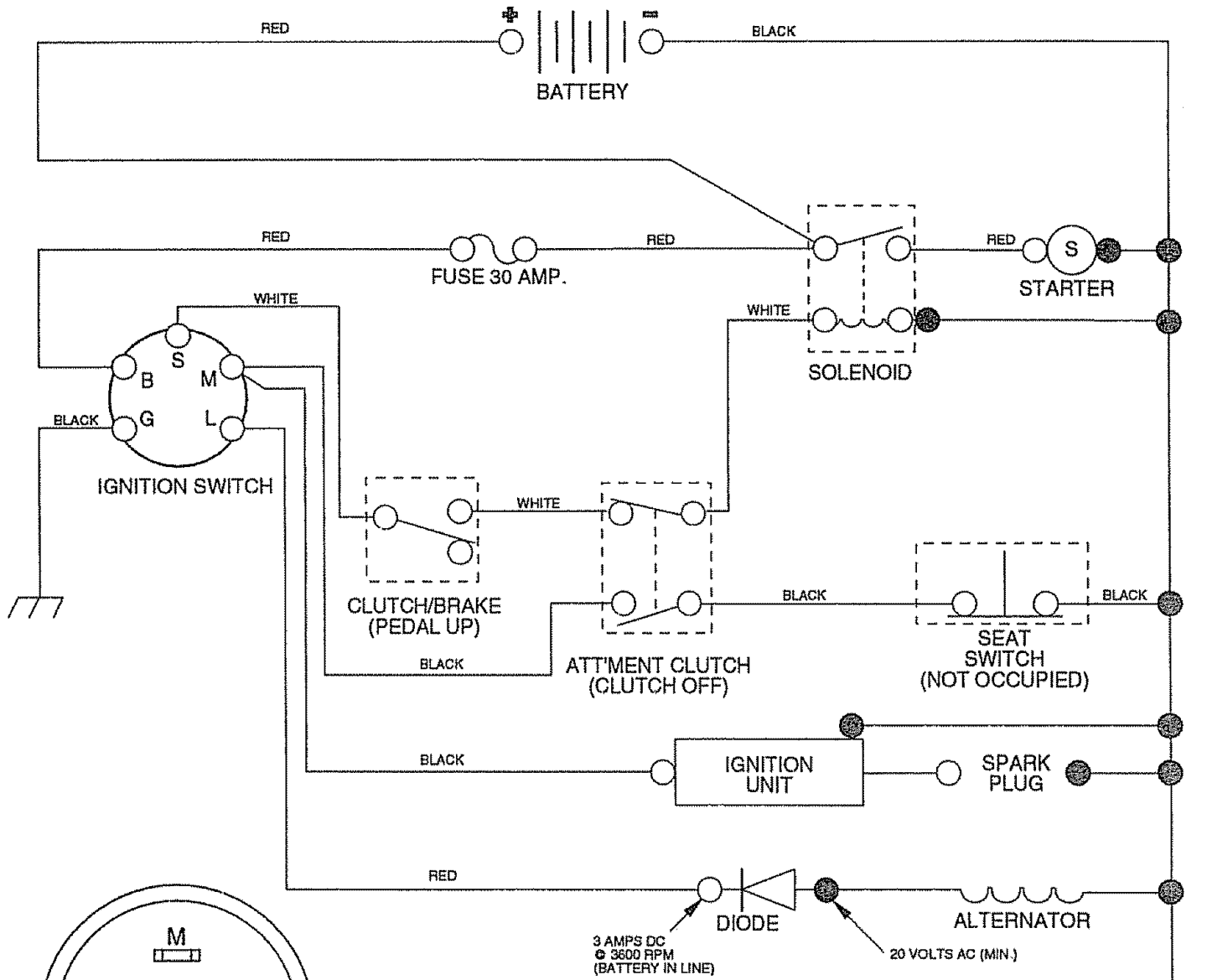

IGNITION SWITCH

POSITION	CIRCUIT
OFF	M + G
ON	B + L
START	B + S

NOTE
 YOUR TRACTOR IS EQUIPPED WITH A SPECIAL ALTERNATOR SYSTEM. THE LIGHTS ARE NOT CONNECTED TO THE BATTERY, BUT HAVE THEIR OWN ELECTRICAL SOURCE. BECAUSE OF THIS, THE BRIGHTNESS OF THE LIGHTS WILL CHANGE WITH ENGINE SPEED. AT IDLE THE LIGHTS WILL DIM. AS THE ENGINE IS SPEEDED UP, THE LIGHTS WILL BECOME THEIR BRIGHTEST.

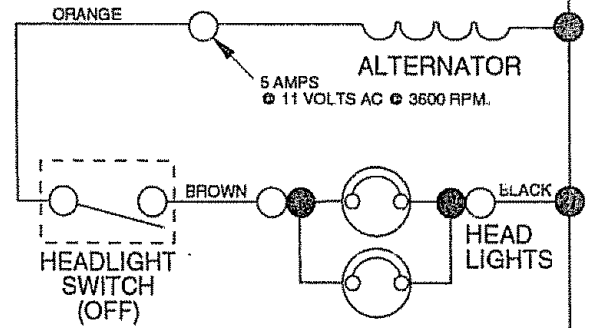

WIRING INSULATED CLIPS

NOTE: If wiring insulated clips were removed for servicing of unit, they should be replaced to properly secure your wiring.

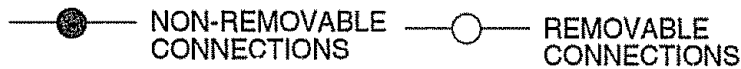

REPAIR PARTS

12 HP 38" TRACTOR - - MODEL NUMBER 917.255561

ELECTRICAL

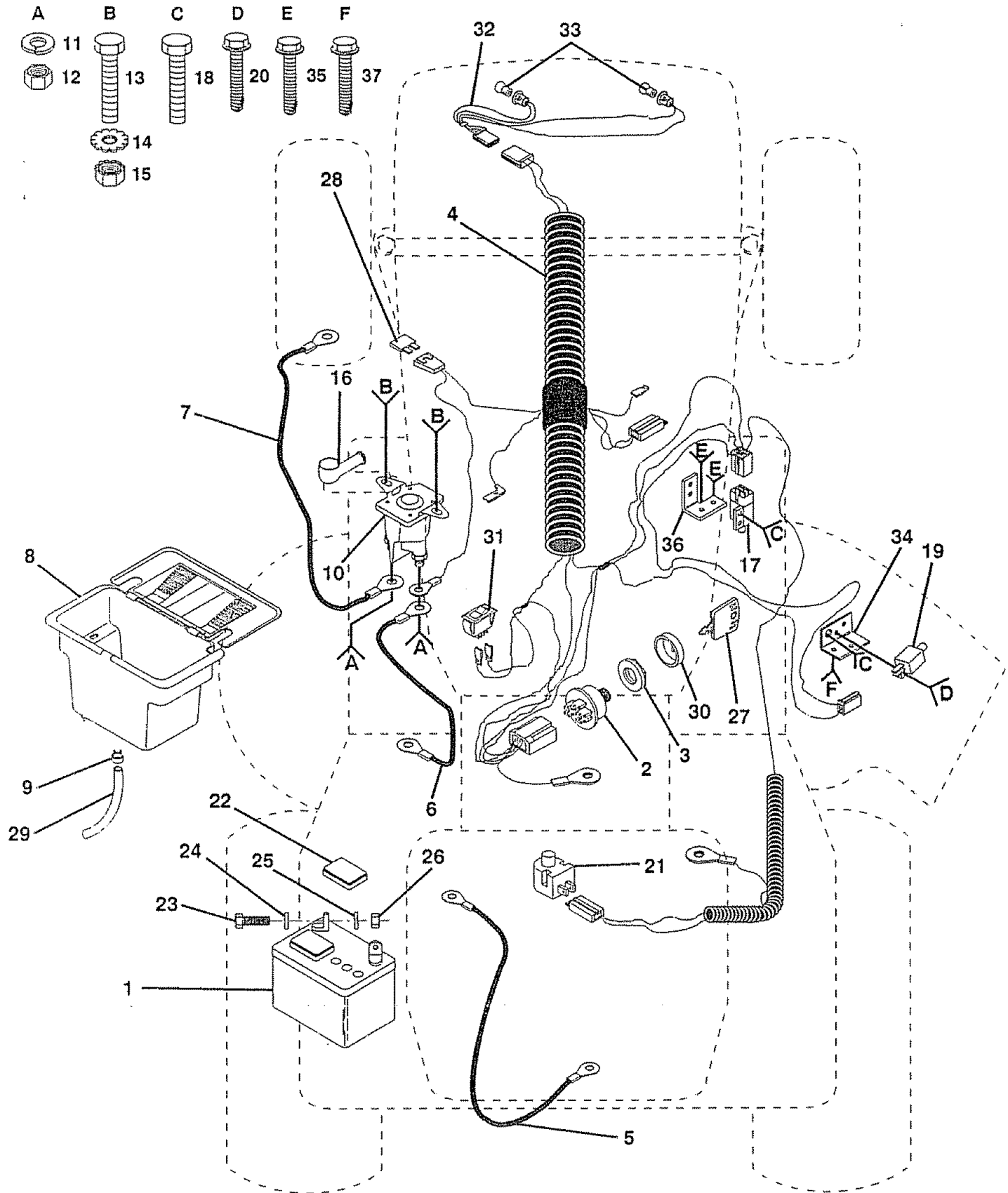

REPAIR PARTS

12 HP 38" TRACTOR - - MODEL NUMBER 917.255561

ELECTRICAL

KEY PART NO.	PART NO.	DESCRIPTION
1	121265X	Battery
2	STD365402	Switch, Ignition
3	124211X	Nut, Ignition
4	132017	Harness, Ignition
5	4207J	Cable, Ground
6	132202	Cable, Battery
7	4799J	Cable, Battery
8	129965	Box, Battery
9	109596X	Clamp, Hose
10	109081X	Solenoid
11	STD551125	Washer, Lock 1/4
12	73350400	Nut, Hex, Jam 1/4-20 UNC
13	74780408	Bolt, Hex Head, Fin. 1/4-20 UNC x 1/2 Grade 5
14	STD551225	Washer, Lock, External Tooth 1/4
15	STD541425	Nut, Hex, Keps 1/4-20 UNC
16	131563	Cover, Terminal
17	109553X	Switch, Interlock, Clutch
18	STD601005	Screw, Hex Head, Self-Tapping #10-24 UNC x 1/2
19	104445X	Switch, Interlock, Clutch
20	STD601005	Screw, Hex Head, Self-Tapping #10-24UNC x 1/2
21	121305X	Switch, Plunger
22	121264X	Cap, Battery
23	74760412	Bolt, Hex Head 1/4-20 UNC x 3/4
24	STD551025	Washer 9/32 x 5/8 x 16 Gauge
25	STD551125	Washer, Lock, Heavy Helical Spring 1/4
26	STD541025	Nut, Hex, Fin. 1/4-20 UNC
27	109310X	Key, Ignition
28	108824X	Fuse, 30 Amp
29	109238X	Tube, Plastic
30	123620X	Cover, Key Switch
31	110712X	Switch, Light
32	127441X	Harness, Light Socket
33	7662J	Bulb, Light
34	108236X	Bracket, Clutch Switch
35	STD601005	Screw, Hex Head, Self-Tapping #10-24UNC x 1/2
36	130890	Bracket Switch Interlock
37	STD601005	Screw, Hex Head, Self-Tapping #10-24UNC x 1/2

NOTE: All component dimensions given in U.S. inches
1 inch = 25.4 mm

REPAIR PARTS

12 HP 38" TRACTOR - - MODEL NUMBER 917.255561

CHASSIS AND ENCLOSURES

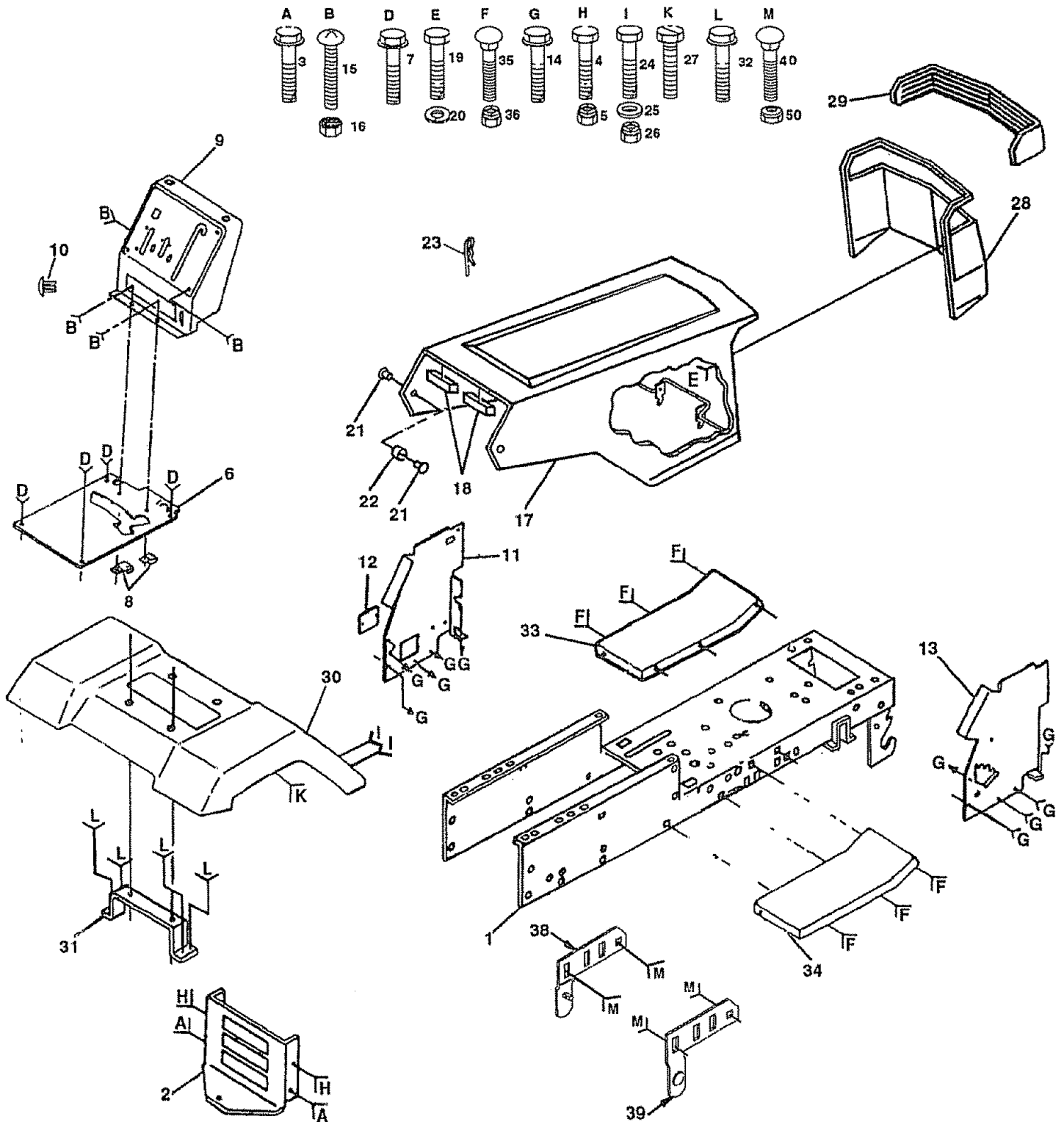

REPAIR PARTS

12 HP 38" TRACTOR - - MODEL NUMBER 917.255561

CHASSIS AND ENCLOSURES

KEY PART NO.	NO.	DESCRIPTION
1	135034	Chassis Assembly
2	127866	Drawbar
3	17490612	Screw, Thd., Roll. 3/8-16 x 3/4
4	STD523707	Bolt, Hex, Fin. 3/8-16 UNC x 3/4
5	STD541437	Nut, Crownlock 3/8-16 UNC
6	124465X014	Saddle
7	17490608	Screw, Thd. Roll. 3/8-16 x 1/2
8	2751R	Clip, Fuel Line
9	123042X012	Dashboard
10	5479J	Plug, Button
11	122795X	Panel, Dash, LH
12	121794X	Cover, Access
13	124031X012	Panel, Dash, RH
14	17490608	Screw, Thd., Roll. 3/8-16 x 1/2
15	74180512	Screw, Machine, Truss Head 5/16-18 UNC x 3/4
16	STD541431	Nut, Hex, Keps 5/16-18 UNC
17	131445X417	Hood Assembly
18	126938X	Bumper, Hood
19	STD512505	Bolt, Hex, Fin. 1/4-20 UNC x 1/2
20	STD551125	Washer, Lock, Heavy Helical Spring 1/4
21	122933X	Rivet, Ratchet, Nylon
22	124479X	Washer, Nylon
23	4921H	Retainer, Spring
24	STD523707	Bolt, Hex, Fin. 3/8-16 UNC x 3/4
25	19131312	Washer 13/32 x 13/16 x 12 Gauge
26	STD541437	Nut, Crownlock 3/8-16 UNC
27	17490608	Screw, Thd., Roll. 3/8-16 x 1/2
28	123915X	Grill
29	124029X	Lens, Headlight Bar, Clear
30	109872X417	Fender
31	109873X	Bracket, Fender
32	17490612	Screw, Thd., Roll. 3/8-16 x 3/4
33	105476X417	Footrest, Perforated, LH
34	105475X417	Footrest, Perforated, RH
35	STD533707	Bolt, Carriage 3/8-16 x 3/4
36	STD541437	Nut, Crownlock 3/8-16 UNC
38	134618	Bracket Assembly, Pivot, Mower, Rear, LH
39	134617	Bracket Assembly, Pivot, Mower, Rear, RH
40	72140606	Bolt, Carriage 3/8-16 x 3/4
50	STD541437	Locknut, Hex, with Washer Insert 3/8-16 UNC

NOTE: All component dimensions given in U.S. inches
1 inch = 25.4 mm

REPAIR PARTS

12 HP 38" TRACTOR - - MODEL NUMBER 917.255561

DRIVE

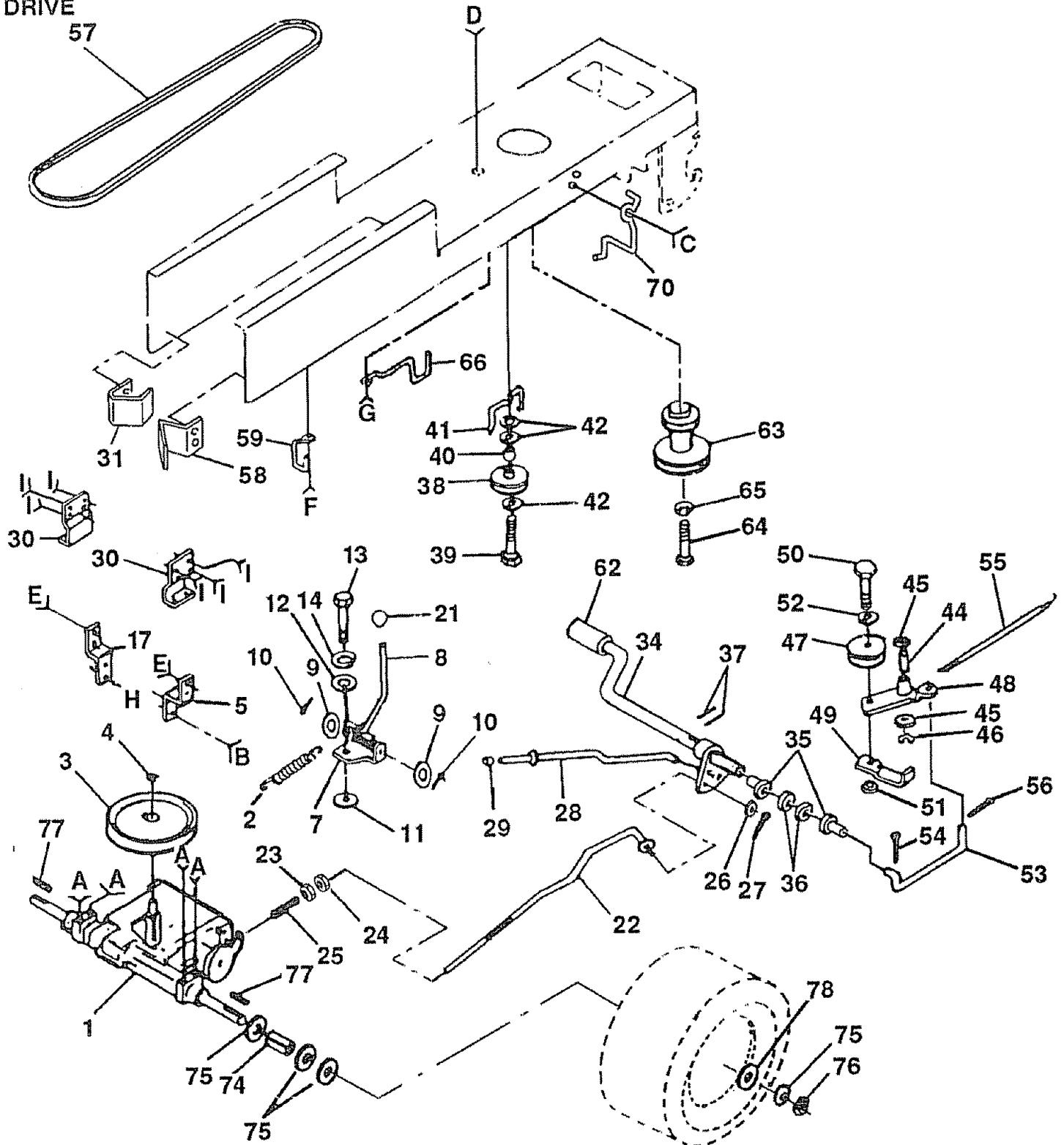

- | | | | | | | | | |
|----------|----------|----------|----------|----------|----------|----------|----------|----------|
| A | B | C | D | E | F | G | H | I |
| | | | | | | | | |
| 15 | 6 | 71 | 43 | 18 | 61 | 67 | 20 | 32 |
| | | | | | | | | |
| 16 | | 72 | | 19 | 60 | 68 | | 33 |
| | | | | | | | | |
| | | 73 | | | | 69 | | |

REPAIR PARTS

12 HP 38" TRACTOR - - MODEL NUMBER 917.255561

DRIVE

KEY PART NO.	PART NO.	DESCRIPTION	KEY PART NO.	PART NO.	DESCRIPTION
1	120897X	Transaxle, Dana, 5 Speed, Model Number 4360-06	39	STD523727	Bolt, Hex, Fin. 3/8-16 UNC x 2-3/4
2	110422X	Spring, Brake Return, Transaxle	40	4470J	Spacer, Split
3	123666X	Pulley, Transaxle	41	109070X	Keeper, Belt Retainer
4	12000028	Ring, Retainer	42	19131312	Washer 13/32 x 13/16 x 12 Gauge
5	121520X	Strap, Torque	43	STD541437	Nut, Crownlock 3/8-16 UNC
6	17490512	Screw, Hex Head, Thd. Roll. 5/16-18 x 3/4	44	105706X	Bearing, Nylon
7	106919X	Plate, Shift	45	110812X	Washer, Hardened
8	124461X	Rod, Shifter	46	12000039	Ring, Klip
9	19151216	Washer 15/32 x 3/4 x 16 Gauge	47	127783	Pulley, Idler, V-Groove
10	STD561210	Pin, Cotter 1/8 x 1	48	123789X	Bellcrank Assembly
11	105701X	Washer, Shift Plate	49	123205X	Retainer, Belt
12	19091210	Washer 9/32 x 3/4 x 10 Gauge	50	STD523715	Bolt, Hex Head 3/8-16 UNC x 1-1/2
13	71040412	Bolt, Hex Head, Fin. 1/4-28 UNF x 3/4 Grade 8	51	STD541437	Nut, Crownlock 3/8-16 UNC
14	STD551125	Washer, Lock, Heavy Helical Spring 1/4	52	STD551037	Washer 13/32 x 13/16 x 16 Gauge
15	STD523727	Bolt, Hex, Fin. 3/8-16 UNC x 2-3/4	53	105710X	Link, Clutch
16	STD541437	Nut, Crownlock 3/8-16 UNC	54	STD561210	Pin, Cotter 1/8 x 3/4
17	121520X	Strap, Torque	55	105709X	Spring, Return, Clutch
18	STD523707	Bolt, Hex, Fin. 3/8-16 UNC x 3/4	56	STD561210	Pin, Cotter 1/8 x 3/4
19	STD541437	Nut, Crownlock 3/8-16 UNC	57	125907X	V-Belt, Ground Drive
20	17490512	Screw, Hex Head, Thd. Roll. 5/16-18 x 3/4	58	127274X	Keeper, Belt, RH
21	106933X	Knob, Round	59	136715	Retainer, Belt, Chassis, LH
22	131867	Rod, Brake	60	19131312	Washer 13/32 x 13/16 x 12 Gauge
23	STD541437	Locknut, Hex, with Washer Insert 3/8-16 UNC	61	17490612	Screw, Hex Head, Thd. Roll. 3/8-16 x 3/4
24	STD541237	Nut, Hex, Jam 3/8-16 UNC	62	8883R	Cover, Pedal
25	106888X	Spring, Brake Rod	63	134825	Pulley, Engine
26	STD551037	Washer 13/32 x 13/16 x 16 Gauge	64	71170764	Bolt, Hex 7/16-20 x 4 Grade 8
27	STD561210	Pin, Cotter 1/8 x 3/4	65	STD551143	Washer, Lock, Heavy Helical Spring 7/16
28	128904	Rod, Parking Brake	66	129921	Keeper, Belt, Engine, LH
29	124236X	Cap, Parking Brake, Red	67	STD523710	Bolt, Hex, Fin. 3/8-16 UNC x 1
30	109167X	Bracket, Transmission	68	19131312	Washer 13/32 x 13/16 x 12 Gauge
31	127275X	Keeper, Belt, LH	69	STD541437	Nut, Crownlock 3/8-16 UNC
32	STD523707	Bolt, Hex, Fin. 3/8-16 UNC x 3/4	70	134683	Guide, Mower Drive Belt, RH
33	STD541437	Nut, Crownlock 3/8-16 UNC	71	STD523710	Bolt, Hex, Fin. 3/8-16 UNC x 1
34	122424X	Shaft Assembly, Foot Pedal	72	19132012	Washer 13/32 x 1-1/4 x 12 Gauge
35	120183X	Bearing, Nylon	73	STD541437	Nut, Crownlock 3/8-16 UNC
36	STD551062	Washer 21/32 x 1 x 16 Gauge	74	109502X	Spacer, Split
37	STD571810	Pin, Roll 3/16 x 1	75	121749X	Washer 25/32 x 1-1/4 x 16 Gauge
38	123674X	Pulley, Idler, Flat	76	STD581075	E-Ring
			77	123583X	Key, Square 2.0 x .1845/.1855
			78	121748X	Washer 25/32 x 1-5/8 x 16 Gauge

NOTE: All component dimensions given in U.S. inches
1 inch = 25.4 mm

REPAIR PARTS

12 HP 38" TRACTOR - - MODEL NUMBER 917.255561

STEERING ASSEMBLY

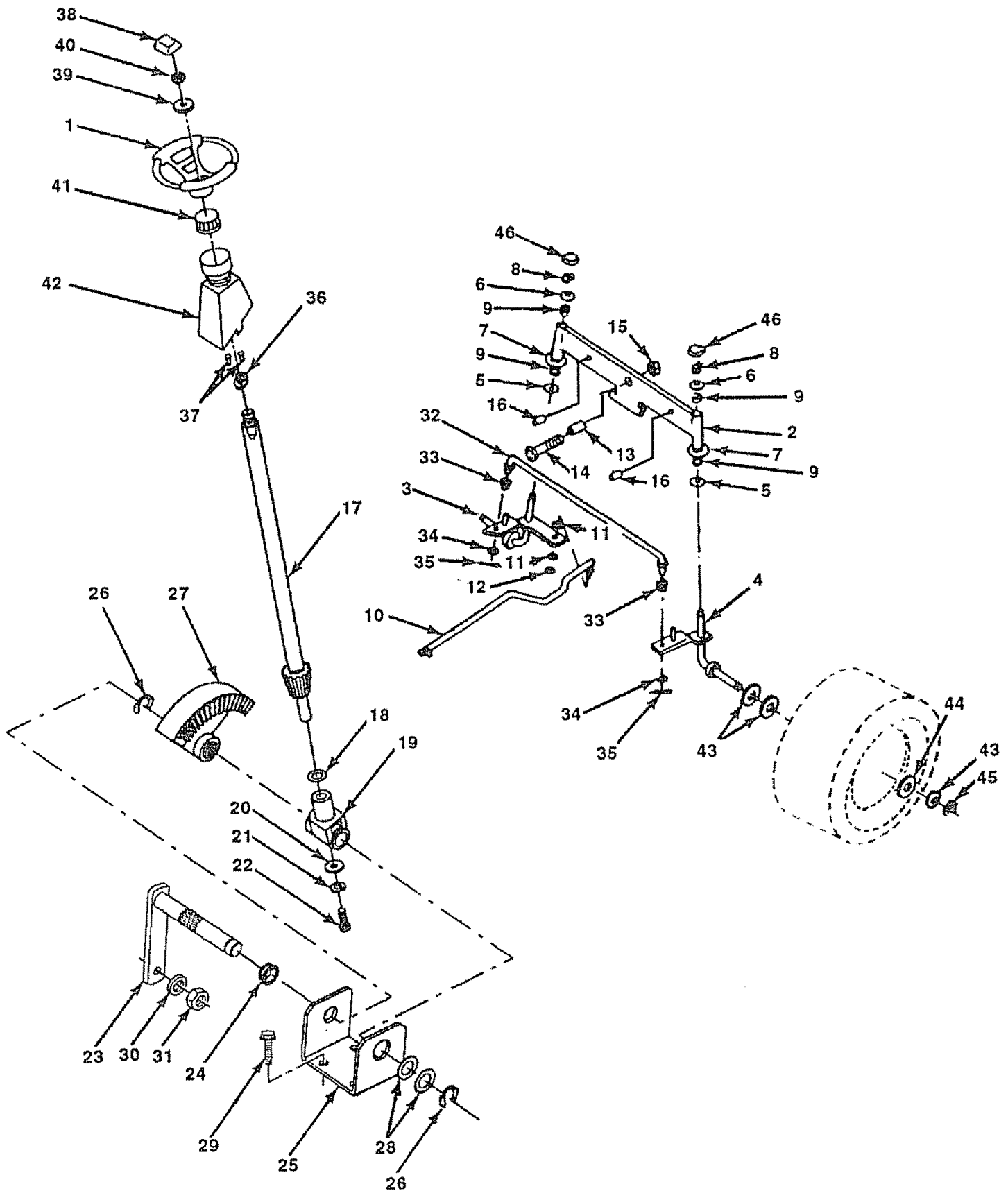

REPAIR PARTS

12 HP 38" TRACTOR - - MODEL NUMBER 917.255561

STEERING ASSEMBLY

KEY PART NO. NO.	DESCRIPTION
1 133741	Steering Wheel
2 131450	Axle Assembly, Front
3 135227	Spindle Assembly, LH
4 135228	Spindle Assembly, RH
5 6266H	Bearing, Thrust
6 121748X	Washer 25/32 x 1-5/8 x 16 Gauge
7 19272016	Washer 27/32 x 1-1/4 x 16 Gauge
8 12000029	Ring, Klip
9 3366R	Bearing, Steering Column
10 130468	Link, Drag
11 STD551137	Washer, Lock, Heavy Helical Spring 3/8
12 73610600	Nut, Hex, Fin. 3/8-24 UNF
13 110438X	Spacer, Bearing, Front Axle
14 74011056	Bolt, Hex Head 5/8-11 UNC x 3-1/2
15 73601000	Locknut, Hex, Jam, with Washer Insert 5/8-11 UNC
16 132624	Pin, Axle 5/8 x 1.55/1.54
17 132614	Shaft Assembly, Steering
18 57079	Washer, Thrust .515 x .750 x .033
19 124035X	Support, Shaft
20 126684X	Washer, Shim 1/4 x 5/8 x .062
21 STD551125	Washer, Lock, Heavy Helical Spring 1/4
22 71070410	Screw, Hex Socket Head 1/4-20 x 5/8
23 127501	Shaft Assembly, Pittman
24 109816X	Nyliner, Snap-In
25 124036X	Bracket, Steering
26 12000029	Ring, Klip
27 124034X	Gear, Sector
28 6266H	Bearing, Thrust
29 17490612	Screw, Thd. Roll. 3/8-16 x 3/4
30 STD551137	Washer, Lock, Heavy Helical Spring 3/8
31 73610600	Nut, Hex, Fin. 3/8-24 UNF
32 130465	Rod, Tie
33 126847X	Bushing, Tie Rod
34 19131416	Washer 13/32 x 7/8 x 16 Gauge
35 STD561210	Pin, Cotter 1/8 x 3/4
36 132196	Bushing, Steering
37 STD611005	Screw, Self-Tapping #10-16 x 1/2
38 133742	Insert, Steering Wheel
39 19133808	Washer 13/32 x 2-3/8 x 8 Gauge
40 STD541537	Nut, Centerlock 3/8-24 UNF
41 104820X	Adaptor, Steering Wheel
42 124417X	Boot, Steering Shaft
43 121749X	Washer 25/32 x 1-1/4 x 16 Gauge
44 121748X	Washer 25/32 x 1-5/8 x 16 Gauge
45 12000029	Ring, Klip
46 121232X	Cap, Spindle

NOTE: All component dimensions given in U.S. inches
1 inch = 25.4 mm

REPAIR PARTS

12 HP 38" TRACTOR - - MODEL NUMBER 917.255561

SEAT ASSEMBLY

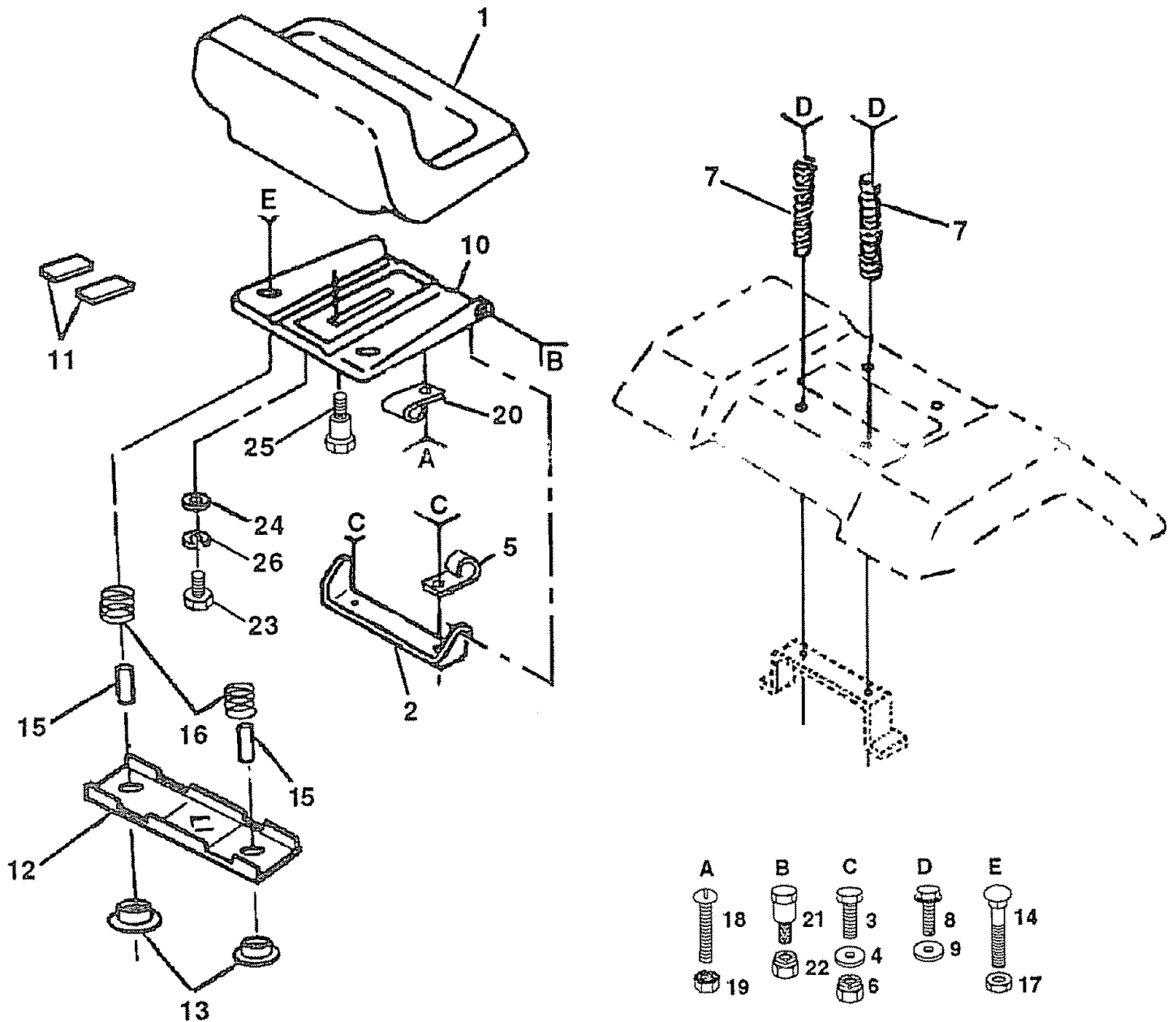

KEY PART NO.	NO.	DESCRIPTION
1	127436	Seat
2	126656X	Bracket, Pivot, Seat
3	STD523707	Bolt, Hex, Fin. 3/8-16 UNC x 3/4
4	19131210	Washer 13/32 x 3/4 x 10 Gauge
5	2751R	Clip, Fuel Line
6	STD541437	Nut, Crownlock 3/8-16 UNC
7	124181X	Spring, Seat
8	17490616	Screw, Thd. Roll. 3/8-16 x 1
9	19131614	Washer 13/32 x 1 x 14 Gauge
10	131451	Pan, Seat
11	121251X	Strip, Foam
12	121246X	Bracket, Switch Mounting
13	121248X	Bushing, Snap
14	72050411	Bolt, Carriage 1/4-20 x 1-3/8
15	121249X	Spacer, Split

KEY PART NO.	NO.	DESCRIPTION
16	121250X	Spring
17	123976X	Locknut 1/4 Grade 5
18	STD511005	Screw, Slotted Pan Head #10-32 x 1/2
19	73951000	Nut, Hex, Keps #10-32 UNF
20	4171R	Clip, Insulated
21	105529X	Bolt, Shoulder 5/16-18 UNC
22	STD541431	Nut, Crownlock 5/16-18
23	74780814	Bolt, Hex, Fin. 1/2-13 x 7/8 Grade 5
24	19171912	Washer 17/32 x 1-3/16 x 12 Gauge
25	127018X	Bolt, Shoulder 5/16-18 x .62
26	STD551150	Washer, Lock, Heavy Helical Spring 1/2

NOTE: All component dimensions given in U.S. inches
1 inch = 25.4 mm

REPAIR PARTS

12 HP 38" TRACTOR - - MODEL NUMBER 917.255561

DECALS

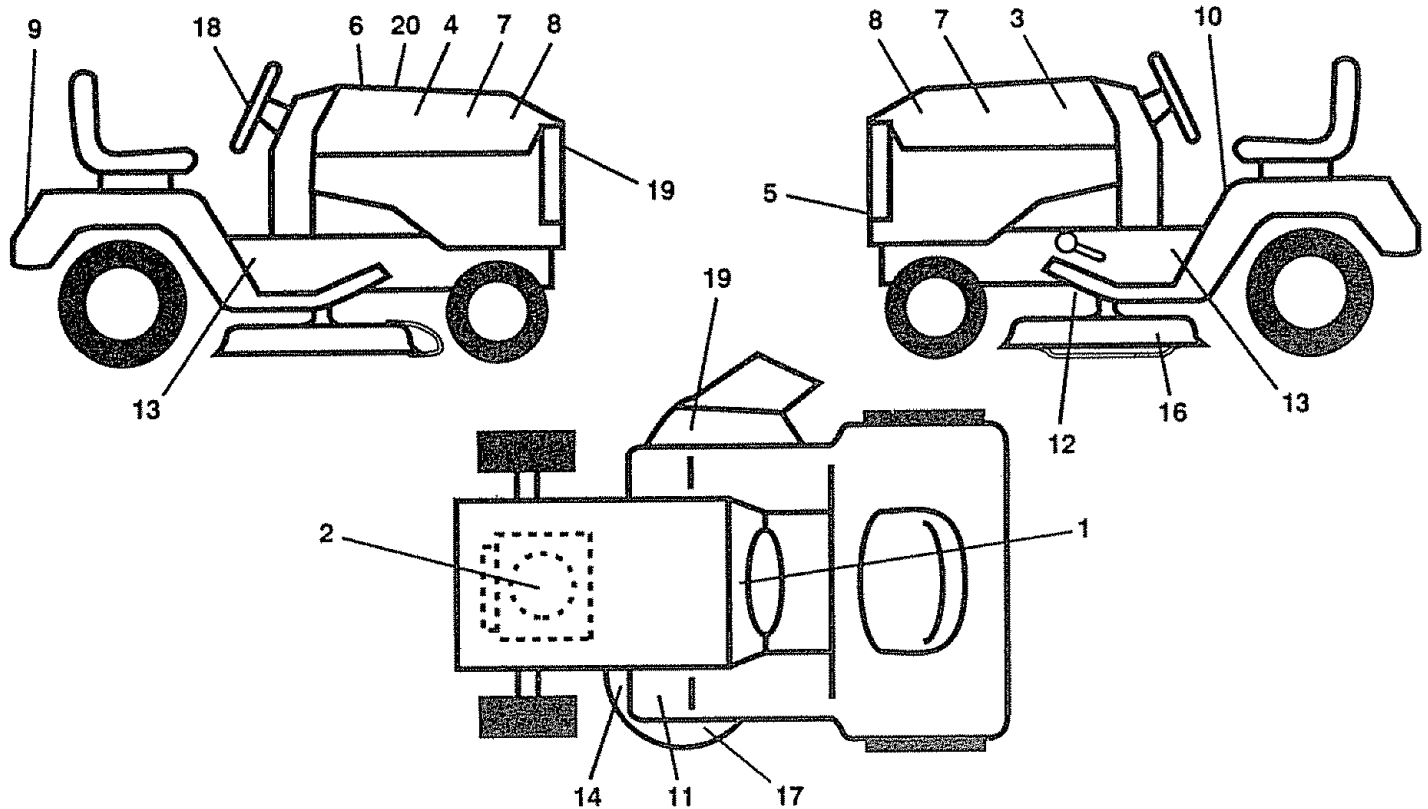

KEY PART NO. NO.

DESCRIPTION

1	108456X	Decal, Operating Instruction
2	126685X	Decal, 12 HP IC, B&S, Engine
3	124490X	Decal, Craftsman, Hood, RH
4	124489X	Decal, Craftsman, Hood, LH
5	132674	Decal, LT4000, Craftsman, Grill
6	133644	Decal, Maintenance
7	136329	Decal, 12 HP IC, Side Panel
8	108631X	Decal, II
9	125880X	Decal, Craftsman, Fender
10	133796	Decal, Caution
11	4900J	Decal, Clutch/Brake

KEY PART NO. NO.

DESCRIPTION

12	109199X	Decal, V-Belt Drive Schematic
13	105809X	Decal, 5 Speed, 38", Chassis
14	130929	Decal, Mower Drive Schematic
15	121343X	Decal, Danger
16	3713J	Decal, Rotating Blades
17	133179	Decal, Mower QC System
18	132267	Decal, Craftsman, USA, Steering Wheel Insert
19	131265	Decal, Lightbox
20	133718	Decal, 3 in One, Mower Deck
--	135984	Manual, Owner's

WHEELS & TIRES

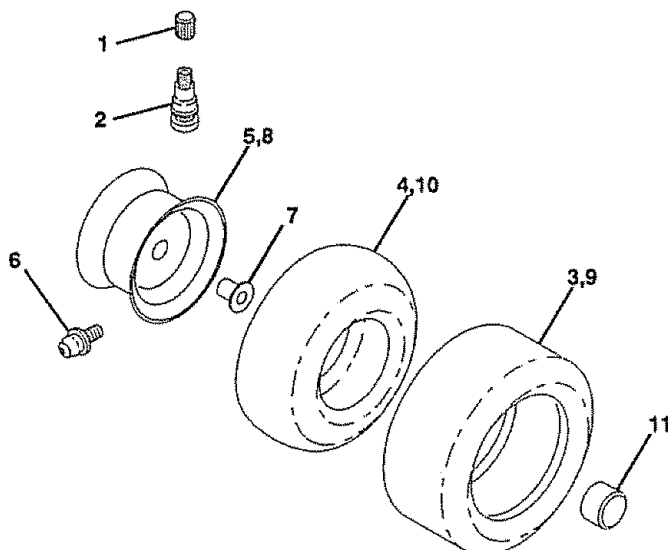

KEY PART NO. NO.

DESCRIPTION

1	59192	Cap, Valve
2	65139	Stem, Valve
3	124157X	Tire, Front
4	59904	Tube, Tire, Front (Optional, Service Item Only)
5	106732X361	Rim Assembly, Front
6	275H	Fitting, Grease
7	9040H	Bearing, Flange
8	106108X361	Rim Assembly, Rear
9	123969X	Tire, Rear
10	7152J	Tube, Tire, Rear (Optional, Service Item Only)
11	104757X	Cover, Axle

NOTE: All component dimensions given in U.S. inches
1 inch = 25.4 mm

REPAIR PARTS

12 HP 38" TRACTOR - - MODEL NUMBER 917.255561

ENGINE

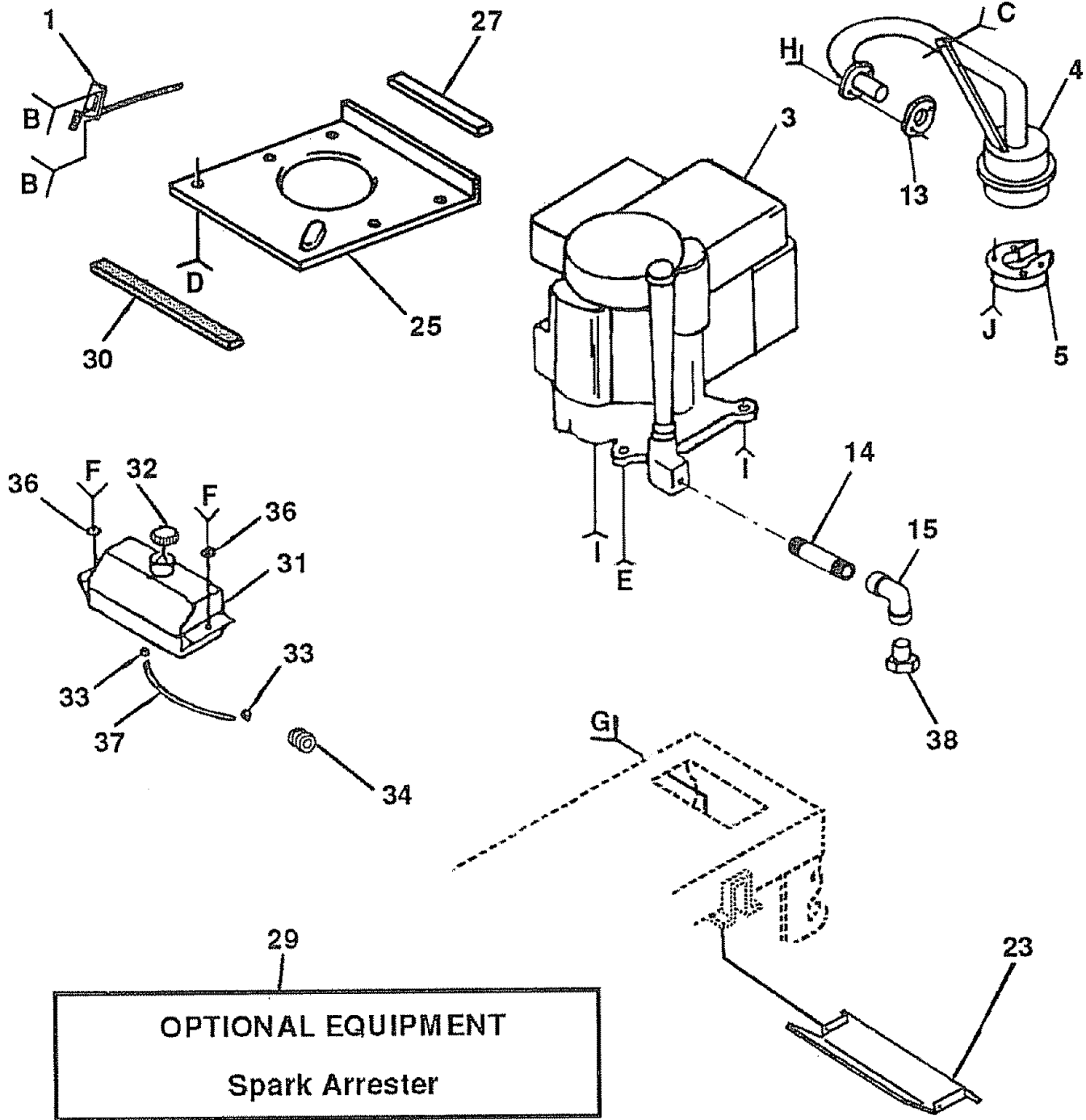

OPTIONAL EQUIPMENT
Spark Arrester

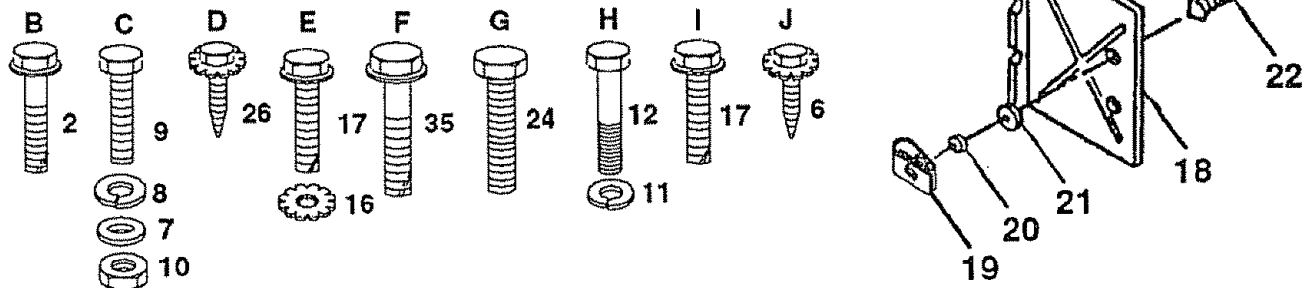

REPAIR PARTS

12 HP 38" TRACTOR - - MODEL NUMBER 917.255561

ENGINE

KEY PART NO.	NO.	DESCRIPTION
1	132759	Control, Throttle
2	17720410	Screw, Hex Head, Thread Cutting 1/4-20 x 5/8
3	131951	Engine, Briggs and Stratton, 12 HP IC, Model Number 283707, Type Number 0217-01
4	125610X	Muffler, Exhaust
5	101326L	Deflector, Muffler
6	17030808	Screw, Hex Head, Spiderlock #8 x 1/2 AB
7	STD551025	Washer 9/32 x 5/8 x 16 Gauge
8	STD551125	Washer, Lock, Heavy Helical Spring 1/4
9	STD522510	Bolt, Hex Head, Fin. 1/4-20 UNC x 1
10	73220500	Nut, Hex, Fin. 5/16-18 UNC
11	STD551131	Washer, Lock, Heavy Helical Spring 5/16
12	71070510	Screw, Hex Cap Head 5/16-18 x 5/8
13	125593X	Gasket
14	13280324	Nipple, Pipe 3/8 NPT x 3
15	13200300	Elbow, Standard 90° 3/8-18 NPT
16	STD551237	Washer, Lock, External Tooth 3/8
17	17490620	Screw, Thd., Roll. 3/8-16 x 1-1/4
18	105736X	Shield, Heat
19	105839X	Receptacle, 1/4 Turn
20	105838X	Retainer, 1/4 Turn
21	STD551025	Washer 9/32 x 5/8 x 16 Gauge
22	123650X	Stud, 1/4 Turn
23	128953	Shield, Heat
24	STD601005	Screw, Hex Head, Self-Tapping #10-24 UNC x 1/2
25	124027X	Shield, Heat, Hood
26	17030808	Screw, Hex Head, Spiderlock #8 x 1/2 AB
27	105037X	Strip, Foam
29	121851X	Arrestor, Spark
30	127057X	Strap, Hood
31	109202X	Tank, Fuel
32	123549X	Cap Assembly, Fuel Tank, Vented
33	123487X	Clamp, Hose
34	124028X	Bushing, Snap, Nylon, Fuel Line
35	17490412	Screw, Hex Washer Head, Thd., Roll. 1/4-20 x 3/4
36	19091416	Washer 9/32 x 7/8 x 16 Gauge
37	101335K	Line, Fuel
38	- - -	Plug, Oil Drain (Order From Engine Manufacturer)

NOTE: All component dimensions given in U.S. inches
1 inch = 25.4 mm

REPAIR PARTS

12 HP 38" TRACTOR - - MODEL NUMBER 917.255561

38" MOWER

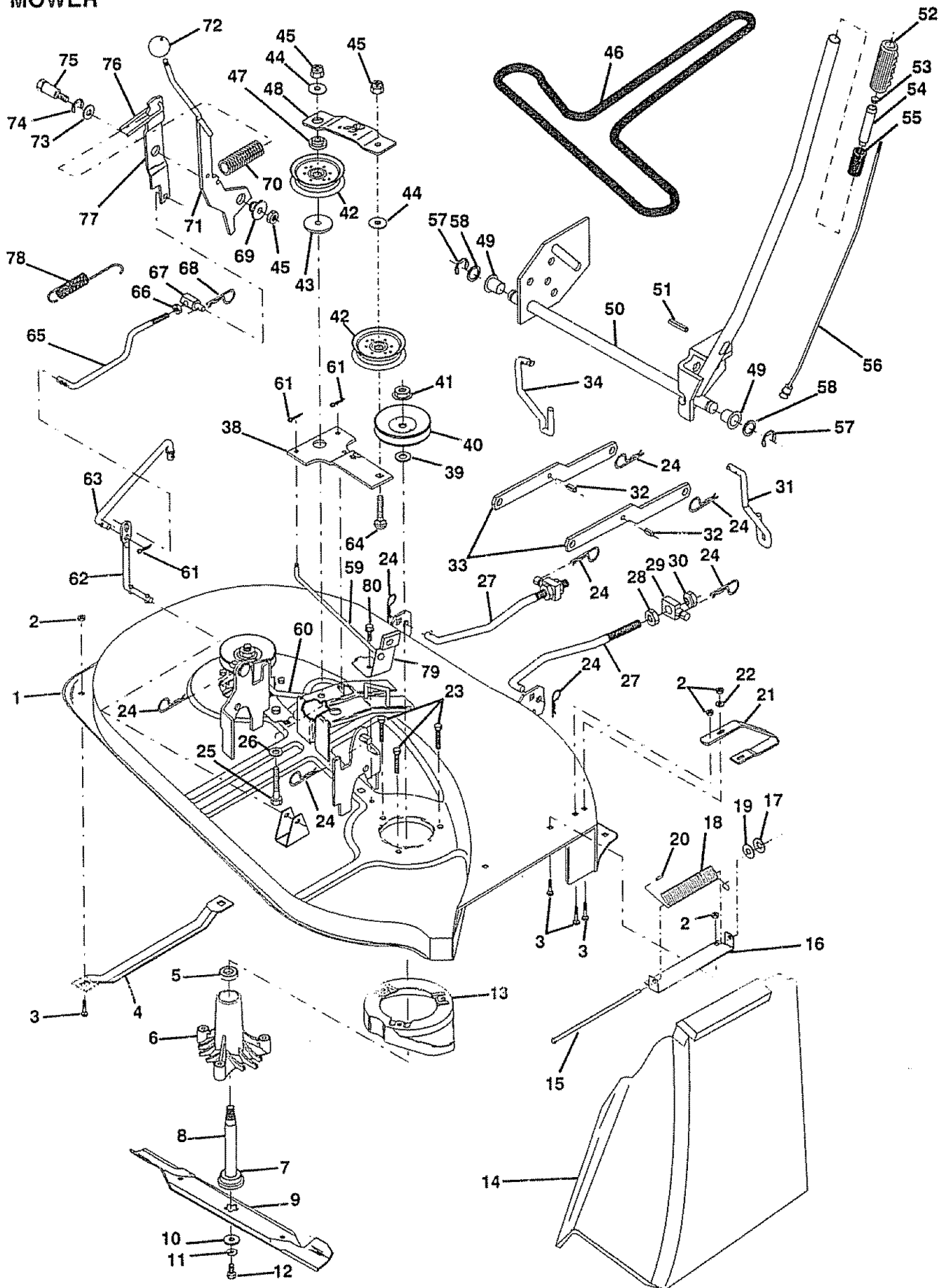

REPAIR PARTS

12 HP 38" TRACTOR - - MODEL NUMBER 917.255561

38" MOWER

KEY PART NO. NO.	DESCRIPTION	KEY PART NO. NO.	DESCRIPTION
1 129365	Mower Housing Assembly	45 STD541437	Nut, Crownlock 3/8-16
2 STD541431	Nut, Crownlock 5/16-18	46 131290	Belt
3 STD533107	Bolt, Carriage 5/16-18 x 3/4	47 133502	Spacer, Retainer
4 7631J	Runner, LH	48 133503	Stiffener, Idler Arm
5 110485X	Ball Bearing, Mandrel	49 120183X	Bearing, Nylon
6 128774	Mandrel Housing, Vented	50 122507X	Lift Shaft Assembly
7 129895	Ball Bearing	51 105767X	Pin, Groove
8 133172	Shaft and Bearing Assembly (Includes Key Number 7)	52 125631X	Grip, Handle
9 127842	Blade, Mower, High Performance	53 122365X	Button, Plunger
10 129962	Washer, Hardened	54 122364X	Plunger, Lever
11 STD551137	Washer, Lock, Heavy Helical Spring 3/8	55 122512X	Spring
12 850857	Bolt, Hex 3/8-24 x 1-1/4 Grade 8	56 122514X	Rod, Lever
13 128961	Stripper, Mower, Vented	57 STD581062	E-Ring
14 106736X	Shield, Deflector	58 19211621	Washer 21/32 x 7/8 x 16 Gauge
15 106735X	Rod, Hinge	59 131288	Rod, Brake, RH
16 105896X	Bracket, Mower Deflector	60 131289	Rod, Brake, LH
17 110452X	Nut, Push	61 STD560907	Pin, Cotter 3/32 x 3/4
18 106734X	Spring, Deflector	62 133551	Rod, Pivot
19 19111016	Washer 11/32 x 3/4 x 16 Gauge	63 133504	Rod, Clutch, Secondary
20 105304X	Cap, Sleeve	64 STD533717	Bolt, Carriage 3/8-16 x 1-3/4
21 128772	Runner, RH	65 134666	Rod, Clutch, Primary
22 19111216	Washer 11/32 x 3/4 x 16 Gauge	66 73350600	Nut, Hex, Jam 3/8-16
23 78158	Bolt, Mandrel	67 133205	Trunnion 3/8-16
24 STD624008	Retainer, Spring	68 STD624003	Retainer, Spring
25 74600636	Bolt, Hex Head 3/8-16 x 2-1/4	69 127498	Bushing
26 19131612	Washer 13/32 x 1 x 12 Gauge	70 128759	Spring
27 127218	Link, Front	71 133573	Arm, Clutch, Primary
28 73350800	Nut, Hex, Jam 1/2-13	72 106932X	Knob
29 130171	Trunnion	73 121748X	Washer 25/32 x 1-5/8 x 16 Gauge
30 73800800	Nut, Crownlock 1/2-13	74 12000029	Ring, Klip
31 135388	Lift, Link, RH	75 128903	Bolt, Shoulder
32 135563	Pin, Spring 5/16-3/4	76 127845	Keeper, Spring
33 130833	Arm, Suspension, Rear	77 127847	Arm, Clutch, Secondary
34 134619	Link, Lift, LH	78 131870	Spring, Return
38 133840	Idler Arm Assembly	79 130840	Brake Assembly
39 129963	Washer, Spacer	80 17490512	Screw, Hex Head, Thd., Roll. 5/16-18 x 3/4
40 129206	Pulley, Mandrel, Single	-- 131455	Mower Deck, Complete
41 73050900	Nut, Flangelock 9/16	-- 130794	Mandrel Assembly (Includes Key Numbers 5-8, 10-12, 39 and 41)
42 131494	Pulley, Idler, Flat		
43 122052X	Spacer, Retainer 1-3/4		
44 19131612	Washer 13/32 x 1 x 12 Gauge		

NOTE: All component dimensions given in U.S. inches
1 inch = 25.4 mm

REPAIR PARTS

12 HP 38" TRACTOR - - MODEL NUMBER 917.255561

DANA TRANSAXLE - MODEL NUMBER 4360-06

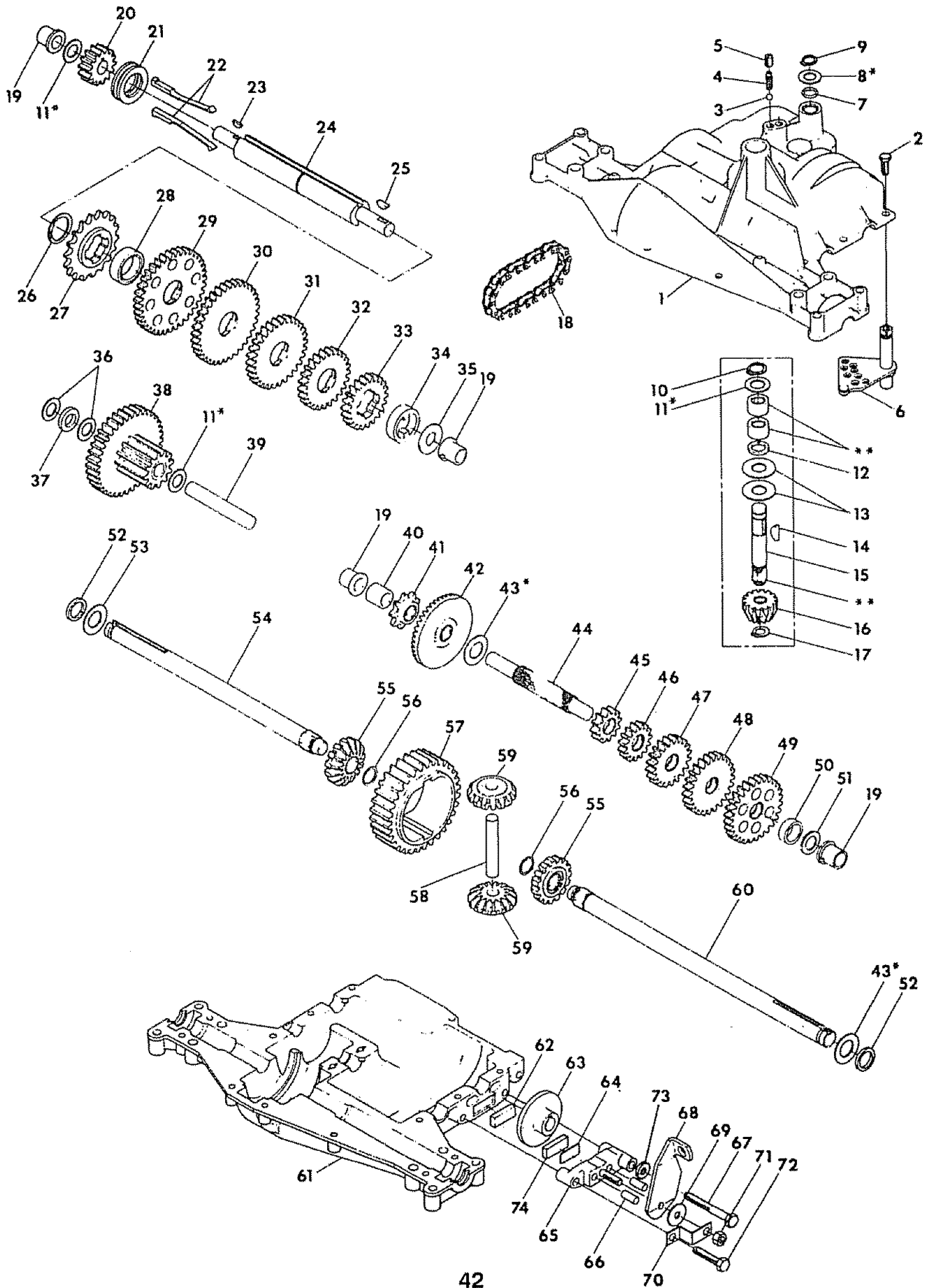

REPAIR PARTS

12 HP 38" TRACTOR - - MODEL NUMBER 917.255561

DANA TRANSAXLE - MODEL NUMBER 4360-06

KEY PART NO.	NO.	DESCRIPTION	KEY PART NO.	NO.	DESCRIPTION
1	120458X	Housing, Upper	41	105928X	Sprocket, 9 Teeth
2	2274J	Screw, Tapping, Large 1/4-20 x .734	42	110084X	Gear, Bevel, 42 Teeth
3	68003	Ball, Detent	43	108983X	* Washer, Plain .758 x 1.12 x .010
4	105904X	Spring, Detent		105930X	* Washer, Plain .758 x 1.12 x .015
5	105905X	Screw, Set		105931X	* Washer, Plain .758 x 1.12 x .020
6	120460X	Shifter Assembly		105932X	* Washer, Plain .758 x 1.12 x .025
7	120461X	O-Ring		3417J	* Washer, Plain .758 x 1.25 x .020
8	120462X	* Washer, Plain .505 x .942 x .006		106097X	* Washer, Plain .758 x 1.25 x .025
	120463X	* Washer, Plain .505 x .942 x .010		2264J	* Washer, Plain .758 x 1.25 x .031
	120464X	* Washer, Plain .505 x .942 x .015		106098X	* Washer, Plain .758 x 1.25 x .035
	120465X	* Washer, Plain .505 x .942 x .020		2265J	* Washer, Plain .758 x 1.25 x .040
	120466X	* Washer, Plain .505 x .942 x .026		106586X	* Washer, Plain .758 x 1.25 x .045
	83818	* Washer, Plain .505 x .942 x .030		106587X	* Washer, Plain .758 x 1.25 x .050
	120467X	* Washer, Plain .505 x .942 x .040		106588X	* Washer, Plain .758 x 1.25 x .055
9	2286J	Ring, Retaining		2263J	* Washer, Plain .758 x 1.25 x .062
10	2267J	Ring, Retaining	44	120473X	Shaft, Drive
11	3413J	* Washer, Plain .632 x 1.00 x .010	45	105933X	Gear, Spur, 12 Teeth
	2233J	* Washer, Plain .632 x 1.00 x .020	46	124641X	Gear, Spur, 20 Teeth
	2232J	* Washer, Plain .632 x 1.00 x .026	47	106589X	Gear, Spur, 25 Teeth
	2231J	* Washer, Plain .632 x 1.00 x .031	48	120408X	Gear, Spur, 28 Teeth
	2230J	* Washer, Plain .632 x 1.00 x .036	49	105937X	Gear, Spur, 31 Teeth
	2229J	* Washer, Plain .632 x 1.00 x .041	50	105936X	Spacer .781 x 1.00 x .375
	2228J	* Washer, Plain .632 x 1.00 x .046	51	2226J	Washer, Plain .632 x 1.00 x .060
	2227J	* Washer, Plain .632 x 1.00 x .050	52	2272J	Seal, Felt
	2226J	* Washer, Plain .632 x 1.00 x .060	53	2263J	Washer, Plain .758 x 1.25 x .062
	105906X	* Washer, Plain .632 x 1.00 x .082	54	120474X	Axle, Left Hand
12	6725J	O-Ring	55	110081X	Gear, Miter, 15 Teeth
13	120415X	Washer, Plain .632 x 1.38 x .046	56	105941X	Ring, Retaining
14	2257J	Key, Woodruff, #9	57	110071X	Gear, Spur, 32 Teeth
15	110077X	Kit, Input Shaft Assembly	58	120952X	Shaft, Cross
16	110078X	Pinion, Bevel, 14 Teeth	59	110082X	Gear, Miter, 15 Teeth
17	105909X	Ring, Retaining	60	120475X	Axle, Right Hand
18	105910X	Chain, 24 Pitches	61	120476X	Housing, Lower
19	105911X	Bearing, Flange	62	120961X	Puck, Friction
20	108976X	Gear, Spur, 14 Teeth	63	7294J	Disc, Brake
21	105913X	Collar, Clutch	64	108989	Spacer
22	120468X	Key, Clutch	65	120953X	Jaw, Brake
23	2242J	Key, Woodruff, #3	66	120954X	Pin, Dowel
24	120469X	Shaft, Intermediate	67	120955X	Screw, Tapping, Large 5/16-18 x 2.25
25	2244J	Key, Woodruff, #61	68	108992X	Lever, Actuating
26	105916X	Ring, Retaining	69	108996X	Washer, Plain .321 x 1.00 x .055
27	120470X	Sprocket, 18 Teeth	70	120956X	Bracket, Anti-Rotation
28	110070X	Spacer	71	73810500	Locknut 5/16-24
29	108977X	Gear, Spur, 37 Teeth	72	106596X	Screw, Tapping, Large 5/16-18 x 1.44
30	120405X	Gear, Spur, 30 Teeth	73	120993X	Washer, Plain .343 x .81 x .059
31	108980X	Gear, Spur, 25 Teeth	74	120951X	Puck, Friction
32	120406X	Gear, Spur, 22 Teeth	75	120416X	Grease
33	108455X	Gear, Spur, 19 Teeth			
34	105923X	Spacer 1.133 x 1.50 x .375			
35	105925X	Washer, Plain .640 x 1.37 x .061			
36	2232J	Washer, Plain .632 x 1.00 x .026			
37	108978X	Spacer .630 x 1.00 x .169			
38	110079X	Assembly, Gear, Combination of 12 Teeth and 35 Teeth			
39	120471X	Shaft, Idler			
40	120472X	Spacer .635 x .875 x .755			
					* Use In Various Combinations To Maintain Proper Clearances
					** Order Key Number 15

NOTE: All component dimensions given in U.S. inches
1 inch = 25.4 mm

REPAIR PARTS

12 HP 38" TRACTOR - - MODEL NUMBER 917.255561

BRIGGS & STRATTON ENGINE - MODEL NUMBER 283707, TYPE NUMBER 0217-01

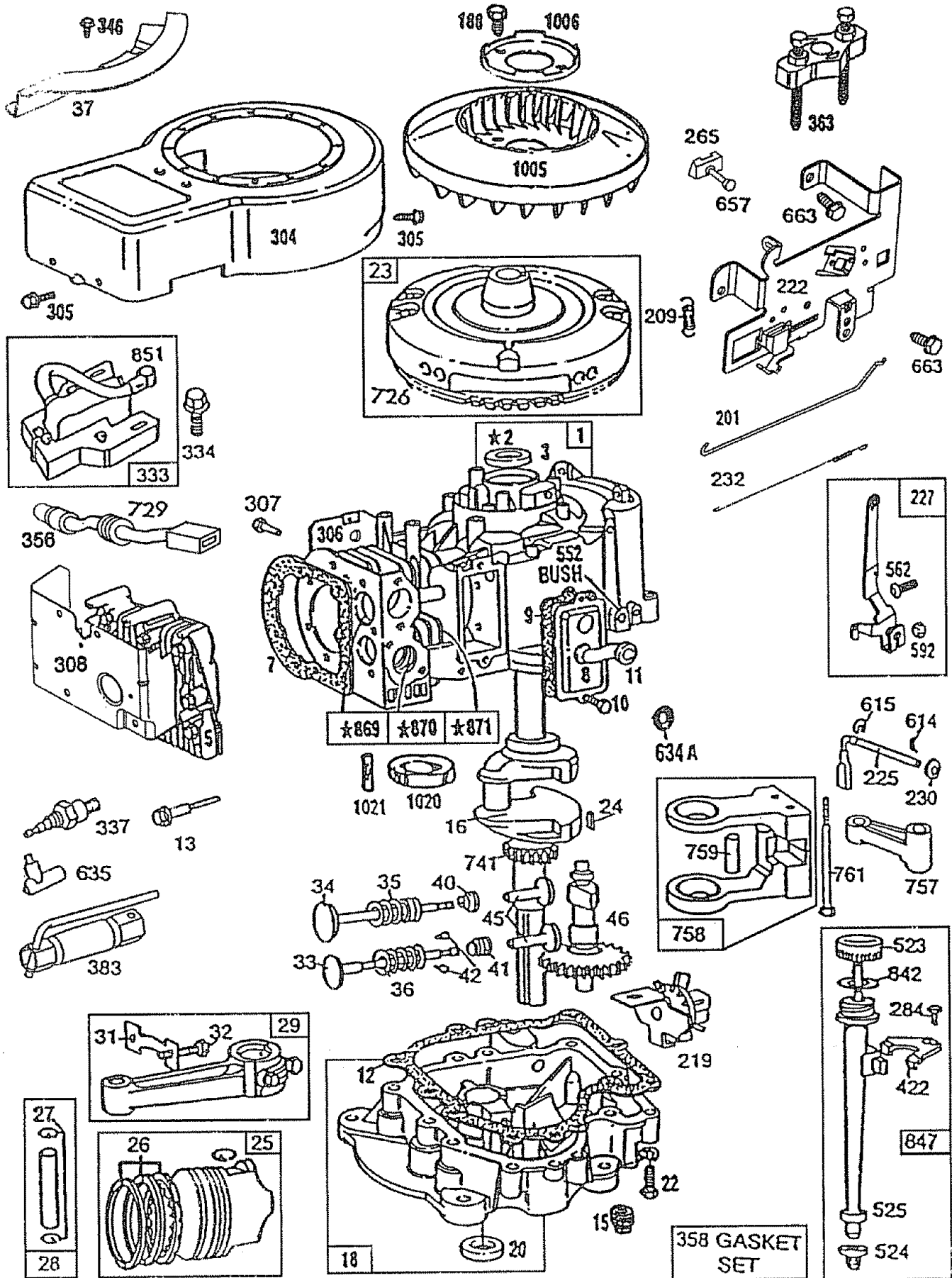

REPAIR PARTS

12 HP 38" TRACTOR -- MODEL NUMBER 917.255561

BRIGGS & STRATTON ENGINE - MODEL NUMBER 283707, TYPE NUMBER 0217-01

121 CARBURETOR OVERHAUL KIT

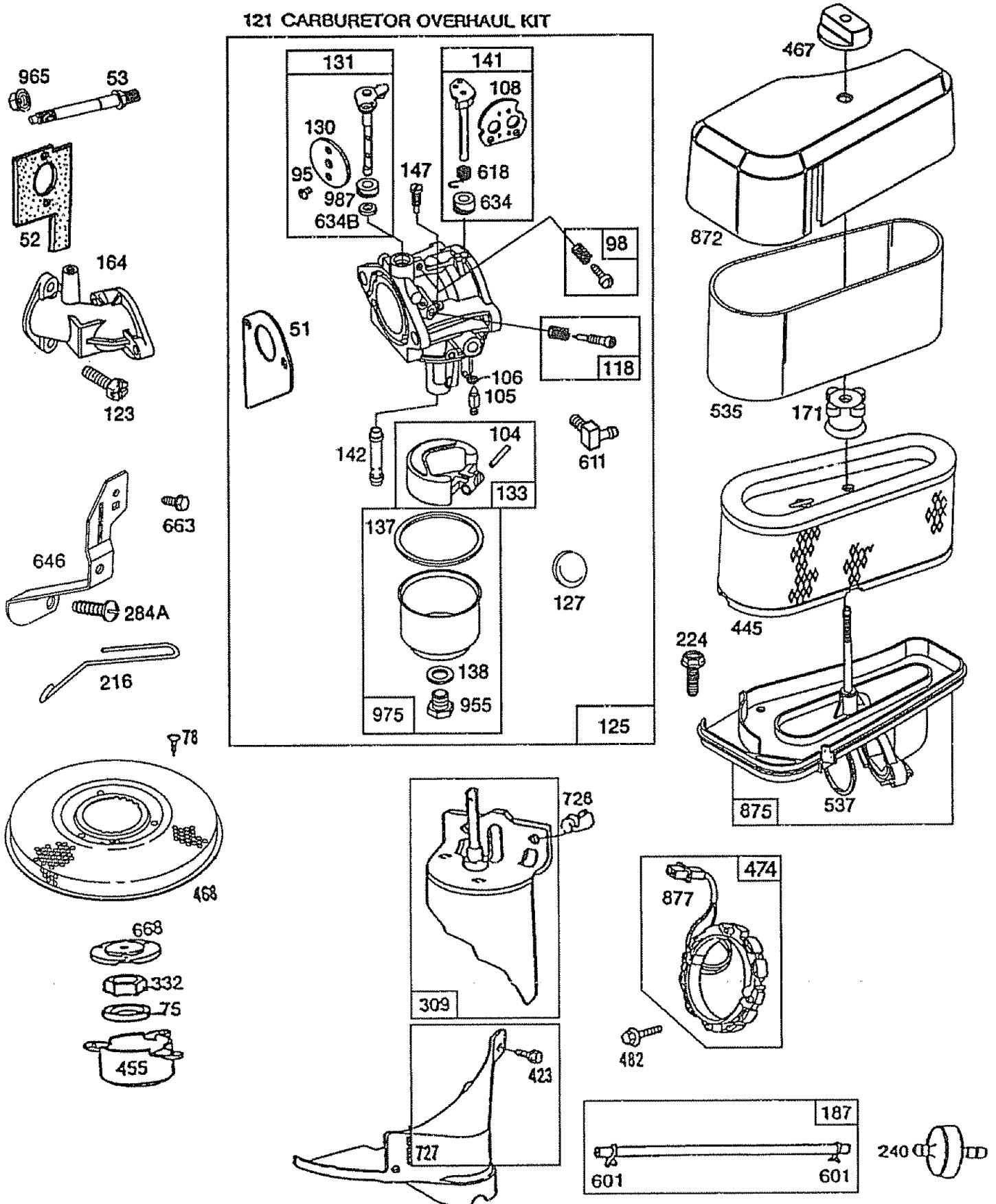

REPAIR PARTS

12 HP 38" TRACTOR - - MODEL NUMBER 917.255561

BRIGGS & STRATTON ENGINE - MODEL NUMBER 283707, TYPE NUMBER 0217-01

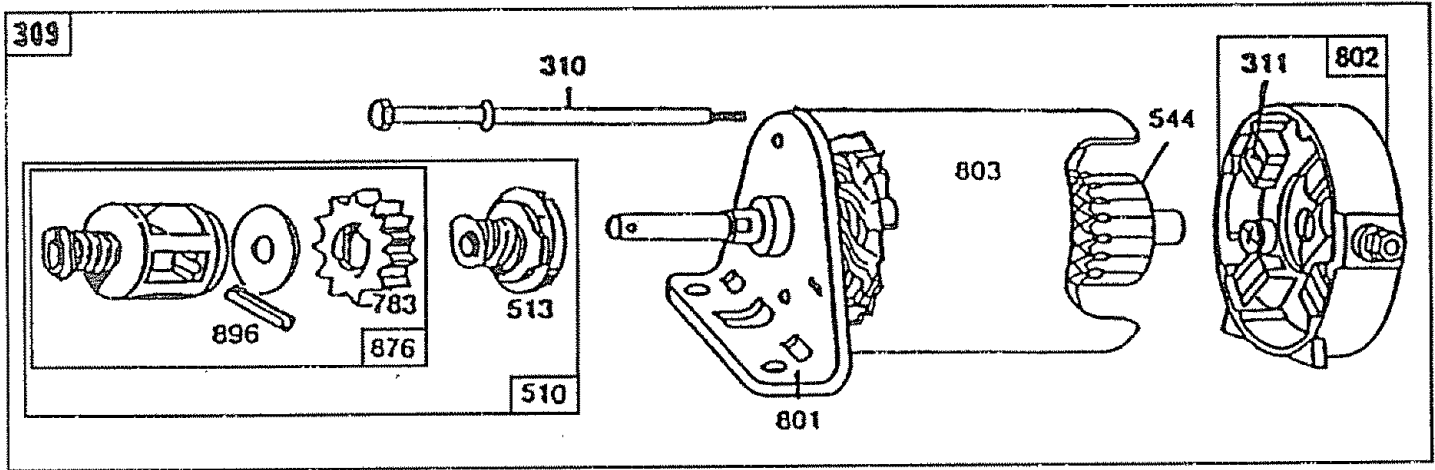

Reference Number		309	310	311	510	544	801	802	803
Manufacturer		Motor and Drive Ass'y.	Thru Bolt Assembly	Brush Assembly	Drive Assembly	Armature Assembly	Drive End Cap Assembly	End Cap Ass'y. Commutator	Housing Assembly
Briggs & Stratton	Housing Length								
12V	3-21/32"	394805	94003	395538	490421**	390837	394856	395537*	393825

*Includes Brush Set

**Includes #398003 Clutch Assembly (Ref. No. 513)
 #280104 Gear (Ref. No. 783)
 #490467 Retainer and Pin (Ref. No. 876)
 # 94288 Roll Pin (Ref. No. 896)

REPAIR PARTS

12 HP 38" TRACTOR - - MODEL NUMBER 917.255561

BRIGGS & STRATTON ENGINE - MODEL NUMBER 283707, TYPE NUMBER 0217-01

KEY PART NO.	NO.	DESCRIPTION	KEY PART NO.	NO.	DESCRIPTION
1	490450	Cylinder Assembly	53	94637	Stud, Carburetor Mounting
2	399265	Bearing, Cylinder (Requires Special Tools For Installation)	75	224061	Washer, Spring
3	391086	* Seal, Oil	78	93805	Screw, Sems
5	494240	Head, Cylinder	95	94098	** Screw, Throttle
7	271866	* Gasket, Cylinder Head	98	494382	Screw, Idle Speed
8	391406	Breather Assembly	104	231789	** Pin, Float Hinge
9	27803	* Gasket, Valve Cover	105	231790	** Valve Assembly, Inlet Needle
10	93394	Screw, Sems	106	281169	Inlet, Valve Seat
11	280100	Tube, Breather	108	224540	Valve, Choke
12	271916	* Gasket, Crankcase Cover 1/64"	118	494383	** Valve, Needle
	271997	* Gasket, Crankcase Cover .005"	121	494384	Carburetor Overhaul Kit
	271996	* Gasket, Crankcase Cover .009"	123	94616	Screw, Elbow Mounting
13	93723	Screw, Cylinder Head	125	494502	Carburetor Assembly
15	94239	Plug, Oil Drain	127	- - -	** Plug, Welch (Sold in Kit Only)
16	490466	Crankshaft	130	224539	Valve, Throttle
	94196	Key, Timing Gear	131	494379	Shaft and Lever, Throttle
18	494238	Base, Engine	133	494381	Float, Carburetor
20	291675	* Seal, Oil	137	281165	*** Gasket, Float Bowl
22	94305	Screw, Sems, Base Mounting	138	281164	*** Washer, Float Bowl Screw
23	492326	Flywheel and Ring Gear Assembly, Magneto	141	494380	** Shaft and Lever, Choke
24	222698	Key, Flywheel	142	494537	** Nozzle / Jet, Carburetor
25	394661	Piston Assembly, Standard		494499	High Altitude Kit:
	394662	Piston Assembly .010" Oversize	147	231794	231796 Pilot, Jet, High Altitude
	394663	Piston Assembly .020" Oversize	164	213819	281164 Seal, Bowl Screw
	394664	Piston Assembly .030" Oversize	171	281051	** Pilot, Jet
26	391780	Ring Set, Piston, Standard Size	187	393815	Carburetor, Elbow
	392331	Ring Set, Piston, Chrome, Standard	188	93535	Nut, Air Cleaner Mounting
	391781	Ring Set, Piston .010" Oversize	201	262767	Line, Fuel
	391782	Ring Set, Piston .020" Oversize	209	260871	Screw, Sems
	391783	Ring Set, Piston .030" Oversize	216	262766	Link, Governor
27	260924	Lock, Piston Pin	219	490815	Spring, Governor
28	299691	Pin Assembly, Piston, Standard			Link, Choke
	391286	Pin Assy., Piston .005" Oversize	222	494887	Oil Slinger, Governor Gear and Bracket Assembly
29	490348	Rod Assembly, Connecting			Plate, Governor Control (Choke-A-Matic)
	490469	Rod Assembly, Connecting, .020" Undersize Crankpin Bore	224	94513	Screw, Sems, Air Cleaner
31	222299	Lock, Connecting Rod Screw	225	231058	Crank, Governor
32	92909	Screw, Connecting Rod	227	493935	Lever Assembly, Governor
33	262246	Valve, Exhaust	230	222450	Washer, Governor Crank
34	262247	Valve, Intake	232	262785	Spring, Governor Link
35	65906	Spring, Intake Valve	240	394358	Filter, Fuel
36	26828	Spring, Exhaust Valve			
37	223752	Guard, Flywheel			
40	221596	Retainer, Intake Valve			
41	292260	Rotocoil, Exhaust Valve			
42	93630	Retainer, Exhaust Valve Rotocoil			
45	262248	Tappet, Valve			
46	212897	Gear, Cam			
51	272465	*** Gasket, Carburetor (Carburetor to Elbow)			
52	270872	* Gasket, Carburetor (Elbow to Cylinder)			

* Included in Gasket Set (494241)
 ** Included in Carburetor Overhaul Kit (494384)
 *** Included in both Carburetor Overhaul Kit (494384) and Carburetor Gasket Set (494385)

NOTE: All component dimensions given in U.S. inches
 1 inch = 25.4 mm

REPAIR PARTS

12 HP 38" TRACTOR - - MODEL NUMBER 917.255561

BRIGGS & STRATTON ENGINE - MODEL NUMBER 283707, TYPE NUMBER 0217-01

KEY PART NO. NO.	DESCRIPTION	KEY PART NO. NO.	DESCRIPTION
265 221535	Clamp, Casing	635 66538	Elbow, Spark Plug
284 94419	Screw, Clamp Mounting	646 224546	Brace, Air Cleaner
284A 94326	Screw, Air Cleaner	657 93496	Screw, Sems
304 494269	Housing, Blower	663 94620	Screw, Hex Head
305 94608	Screw, Sems, Blower Housing Mounting	668 280848	Spacer
306 224545	Shield, Cylinder	726 392134	Gear, Ring (Includes Mounting Parts)
307 93949	Screw, Sems, Cylinder Shield Mounting	727 490324	Cover, Starter (Includes Mounting Screws)
308 491490	Cover, Cylinder Head	728 94627	Screw, Sems
309 - - -	Motor, Starting (See Chart on Illustrated Pages for Replacement Parts for Starting Motors)	729 281159	Clip, Lead Wire
332 92284	Nut, Hex	741 262135	Gear, Timing
333 492341	Armature, Magneto	757 212359	Link, Counterweight
334 93381	Screw, Sems, Armature Mounting	758 399891	Counterweight Assembly
337 802592	Plug, Spark	759 298909	Pin, Counterweight
346 93705	Screw, Hex Head	761 93875	Screw, Counterweight
356 494328	Wire, Ground	842 270920	Seal, Oil Filler Cap
358 494241	Gasket Set	847 490474	Fill Group, Oil
363 19203	Puller, Flywheel	851 221798	Terminal, Ignition Cable
383 89838	Wrench, Spark Plug	869 261463	Seat, Intake Valve, Standard
422 223721	Clamp, Oil Filler Tube	870 213316	Seat, Exhaust Valve, Standard
423 94073	Screw, Sems	871 261961	Guide, Exhaust Valve
445 493909	Cartridge, Air Cleaner	872 281104	Cover, Air Cleaner
455 222561	Cup, Screen Mounting	875 494237	Body, Air Cleaner
467 493903	Knob, Air Cleaner	877 393456	Diode and Connector Assembly, Dual Circuit
468 222562	Screen, Flush Rotating	955 94642	** Screw, Fuel Bowl
474 393474	Stator, Alternator	965 94108	Locknut, Air Cleaner Mounting
482 93621	Screw, Sems	975 494378	Bowl Assembly, Carburetor
523 490327	Cap and Dipstick, Oil Filler	977 494385	Carburetor Gasket Kit
524 68838	Seal, Filler Tube	987 281166	** Seal, Throttle Shaft
525 280741	Tube, Oil Filler	1005 280687	Fan, Flywheel
535 272403	Element, Air Cleaner	1006 224413	Retainer, Fan
537 281106	* O-Ring, Air Cleaner	1020 262243	Eccentric
552 231597	Bushing, Governor Crank	1021 94160	Pin, Eccentric
562 92613	Bolt, Governor Lever		
592 231082	Nut, Hex #10-24		
601 93053	Clamp, Fuel Pipe		
611 494451	Fuel Inlet Tube		
614 93306	Cotter, Hair Pin		
615 93307	Retainer, E-Ring		
618 262803	Spring, Choke Return		
634 281168	** Seal, Choke Shaft		
634A 491323	* Seal, Governor		
634B 281167	Washer, Throttle Shaft		

* Included in Gasket Set (494241)
 ** Included in Carburetor Overhaul Kit (494384)
 *** Included in both Carburetor Overhaul Kit (494384) and Carburetor Gasket Set (494385)

NOTE: All component dimensions given in U.S. inches
 1 inch = 25.4 mm

SERVICE NOTES

SERVICE NOTES

SUGGESTED GUIDE FOR SIGHTING SLOPES FOR SAFE OPERATION

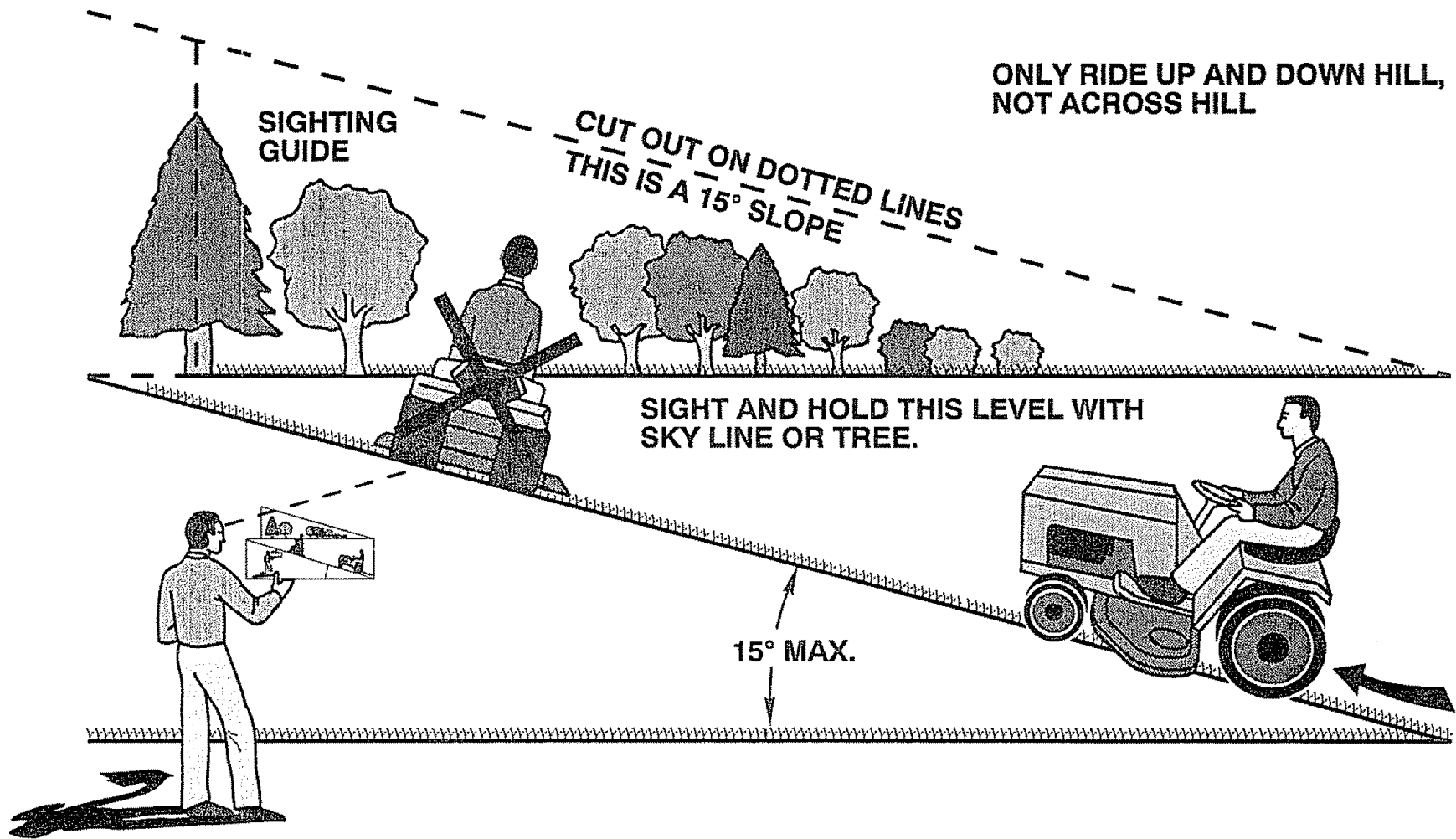

Operate your Tractor up and down the face of slopes (not greater than 15°), never across the face. Make turns gradually to prevent tipping or loss of control. Exercise extreme caution when changing direction on slopes.

SEARS

**OWNER'S
MANUAL**

**MODEL NO.
917.255561**

**HOW TO ORDER
REPAIR PARTS**

CRAFTSMAN®

**12.0 HP IC
ELECTRIC START
38" MOWER DECK
5 SPEED TRANSAXLE
LAWN TRACTOR**

Each tractor has its own model number. Each engine has its own model number.

The model number for your tractor will be found on the model plate located under the seat.

The model number for your engine will be found on the blower housing.

All parts listed herein may be ordered from any Sears, Roebuck and Co. Service Centers and most Retail Stores.

WHEN ORDERING REPAIR PARTS, ALWAYS GIVE THE FOLLOWING INFORMATION:

- PRODUCT - LAWN TRACTOR
- MODEL NUMBER - 917.255561
- ENGINE MODEL NUMBER - 283707, TYPE NUMBER 0217-01
- PART NUMBER
- PART DESCRIPTION

Your Sears merchandise has added value when you consider Sears has service units nationwide staffed with Sears trained technicians... professional technicians specifically trained to insure that we meet our pledge to you, we service what we sell.

Sears, Roebuck and Co., Chicago, IL 60684 U.S.A.