

NordicTrack[®]

Summit 4500

Patent Pending

Model No. NTTL16901

Serial No. _____

Find the serial number in the location shown below. Write the serial number in the space above for reference.

Serial Number Decal

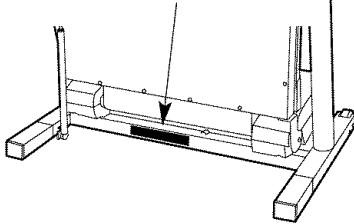

USER'S MANUAL

QUESTIONS?

If you have questions, or if there are missing parts, we will guarantee complete satisfaction through direct assistance from our factory.

TO AVOID UNNECESSARY DELAYS, PLEASE CALL DIRECT TO OUR TOLL-FREE CUSTOMER HOT LINE. The trained technicians on our Customer Hot Line will provide immediate assistance, free of charge to you.

CUSTOMER HOT LINE:

1-888-825-2588

Mon.-Fri., 6 a.m.-6 p.m. MST

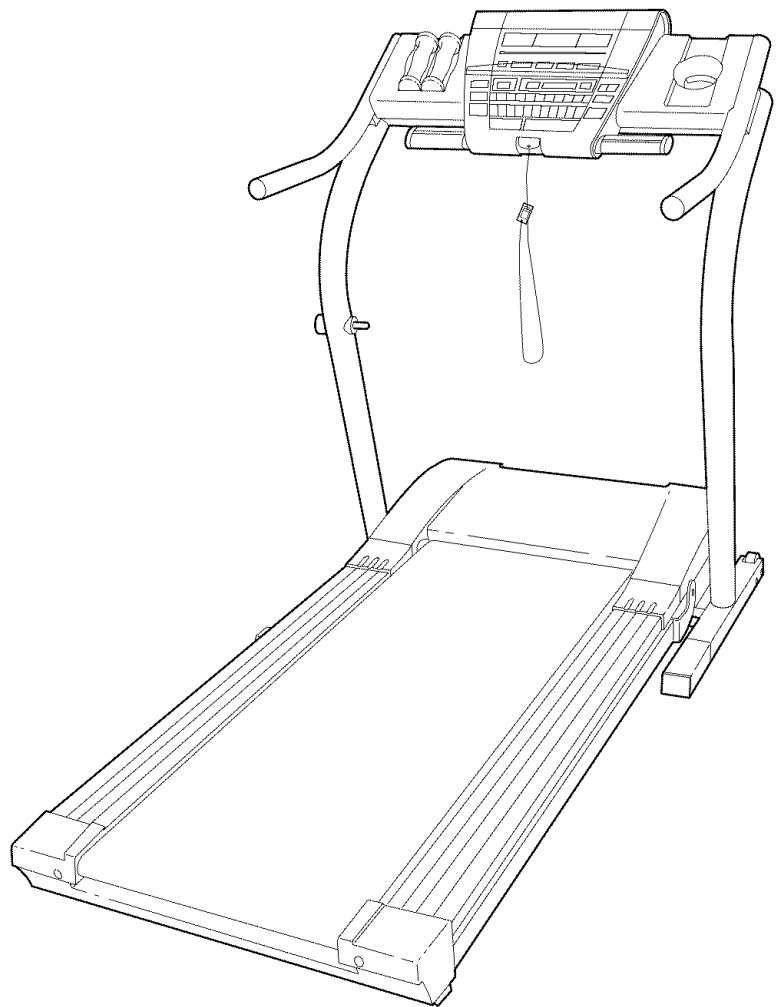

⚠ CAUTION

Read all precautions and instructions in this manual before using this equipment. Save this manual for future reference.



Visit our website at

www.nordictrack.com

new products, prizes,
fitness tips, and much more!



TABLE OF CONTENTS

IMPORTANT PRECAUTIONS	3
BEFORE YOU BEGIN	5
ASSEMBLY	6
OPERATION AND ADJUSTMENT	8
HOW TO FOLD AND MOVE THE TREADMILL	25
TROUBLE-SHOOTING	26
CONDITIONING GUIDELINES	28
PART LIST	30
ORDERING REPLACEMENT PARTS	31
LIMITED WARRANTY	Back Cover

Note: An EXPLODED DRAWING is attached in the center of this manual.

IMPORTANT PRECAUTIONS

⚠ WARNING: To reduce the risk of burns, fire, electric shock, or injury to persons, read the following important precautions and information before operating the treadmill.

1. It is the responsibility of the owner to ensure that all users of this treadmill are adequately informed of all warnings and precautions.
2. Use the treadmill only as described in this manual.
3. Place the treadmill on a level surface, with at least eight feet of clearance behind it. Do not place the treadmill on any surface that blocks air openings. To protect the floor or carpet from damage, place a mat under the treadmill.
4. Keep the treadmill indoors, away from moisture and dust. Do not put the treadmill in a garage or covered patio, or near water.
5. Do not operate the treadmill where aerosol products are used or where oxygen is being administered.
6. Keep children under the age of 12 and pets away from the treadmill at all times.
7. The treadmill should not be used by persons weighing more than 300 pounds.
8. Never allow more than one person on the treadmill at a time.
9. Wear appropriate exercise clothing when using the treadmill. Do not wear loose clothing that could become caught in the treadmill. Athletic support clothes are recommended for both men and women. Always wear athletic shoes. Never use the treadmill with bare feet, wearing only stockings, or in sandals.
10. When connecting the power cord (see page 8), plug the power cord into a surge suppressor (not included) and plug the surge suppressor into a grounded circuit capable of carrying 15 or more amps. No other appliance should be on the same circuit. Do not use an extension cord.
11. Use only a single-outlet surge suppressor that meets all of the specifications described on page 8. To purchase a surge suppressor, see your local NordicTrack dealer or call 1-800-806-3651 and order part number 146148.
12. Failure to use a properly functioning surge suppressor could result in damage to the control system of the treadmill. If the control system is damaged, the walking belt may change speed or stop unexpectedly, which may result in a fall and serious injury.
13. Keep the power cord and the surge suppressor away from heated surfaces.
14. Never move the walking belt while the power is turned off. Do not operate the treadmill if the power cord or plug is damaged, or if the treadmill is not working properly. (See **BEFORE YOU BEGIN** on page 5 if the treadmill is not working properly.)
15. Never start the treadmill while you are standing on the walking belt. Always hold the handrails while using the treadmill.
16. The treadmill is capable of high speeds. Adjust the speed in small increments to avoid sudden jumps in speed.
17. The pulse sensor is not a medical device. Various factors, including the user's movement, may affect the accuracy of heart rate readings. The pulse sensor is intended only as an exercise aid in determining heart rate trends in general.
18. Using hand weights and not holding the handrails may compromise your ability to maintain your balance. Hand weights should be used only by experienced users.
19. Never leave the treadmill unattended while it is running. Always remove the key, unplug the power cord and move the on/off switch to the off position when the treadmill is not in use. (See the drawing on page 5 for the location of the on/off switch.)
20. Do not attempt to raise, lower, or move the treadmill until it is properly assembled. (See **ASSEMBLY** on page 6, and **HOW TO FOLD AND MOVE THE TREADMILL** on page 25.) You must be able to safely lift 45 pounds (20 kg) in order to raise, lower, or move the treadmill.

21. Do not change the incline of the treadmill by placing objects under the treadmill.

22. When folding or moving the treadmill, make sure that the storage latch is fully closed.

23. When using iFIT.com CDs and videos, an electronic "chirping" sound will alert you when the speed and/or incline of the treadmill is about to change. Always listen for the "chirp" and be prepared for speed and/or incline changes. In some instances, the speed and/or incline may change before the personal trainer describes the change.

24. When using iFIT.com CDs and videos, you can manually override the speed and incline settings at any time by pressing the speed and incline buttons. However, when the next "chirp" is heard, the speed and/or incline will change to the next settings of the CD or video program.

25. Always remove iFIT.com CDs and videos from

your CD player or VCR when you are not using them.

26. Inspect and tighten all parts of the treadmill regularly.

27. Never insert or drop any object into any opening.

28. **DANGER:** Always unplug the power cord immediately after use, before cleaning the treadmill, and before performing the maintenance and adjustment procedures described in this manual. Never remove the motor hood unless instructed to do so by an authorized service representative. Servicing other than the procedures in this manual should be performed by an authorized service representative only.

29. This treadmill is intended for in-home use only. Do not use this treadmill in any commercial, rental, or institutional setting.

⚠ WARNING: Before beginning this or any exercise program, consult your physician. This is especially important for persons over the age of 35 or persons with pre-existing health problems. Read all instructions before using. ICON assumes no responsibility for personal injury or property damage sustained by or through the use of this product.

SAVE THESE INSTRUCTIONS

The decals shown below have been placed on your treadmill. If the decal is missing or illegible, please call our Customer Service Department, toll-free, to order a free replacement decal (see ORDERING REPLACEMENT PARTS on page 31). Apply the decal in the location shown.

⚠ WARNING: Protect yourself and others from risk of serious injury. Read the user's manual and:

- Fully engage storage latch before treadmill is moved or stored.
- Reduce incline to lowest level before folding treadmill into storage position.
- Stand only on side rails when starting or stopping treadmill.
- Change speed in small increments.
- Hold handrails to prevent falling, and always wear the safety clip while operating treadmill.
- Stop if you feel faint, dizzy, or short of breath.
- Never allow children on or around treadmill.
- Remove key when not in use.
- Keep clothing, fingers, and hair away from moving belt.
- Never try to adjust or fix the belt while it is moving.
- Always wear athletic shoes while operating treadmill.



Note: This decal is shown at 38% of actual size.

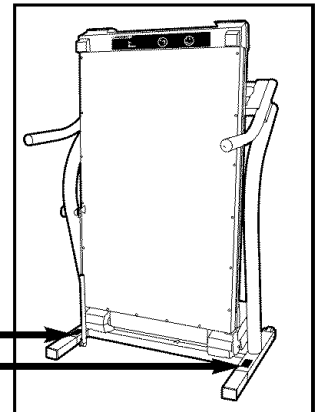

BEFORE YOU BEGIN

Thank you for selecting the revolutionary NordicTrack® SUMMIT 4500 treadmill. The SUMMIT 4500 treadmill combines advanced technology with innovative design to help you get the most from your exercise program in the convenience of your home. And when you're not exercising, the unique SUMMIT 4500 can be folded up, requiring less than half the floor space of other treadmills.

please call our Customer Service Department toll-free at 1-888-825-2588, Monday through Friday, 6 a.m. until 6 p.m. Mountain Time (excluding holidays). To help us assist you, please note the product model number and serial number before calling. The model number of the treadmill is NTTL16901. The serial number can be found on a decal attached to the treadmill (see the front cover of this manual for the location).

For your benefit, read this manual carefully before using the treadmill. If you have additional questions,

Before reading further, please familiarize yourself with the parts that are labeled in the drawing below.

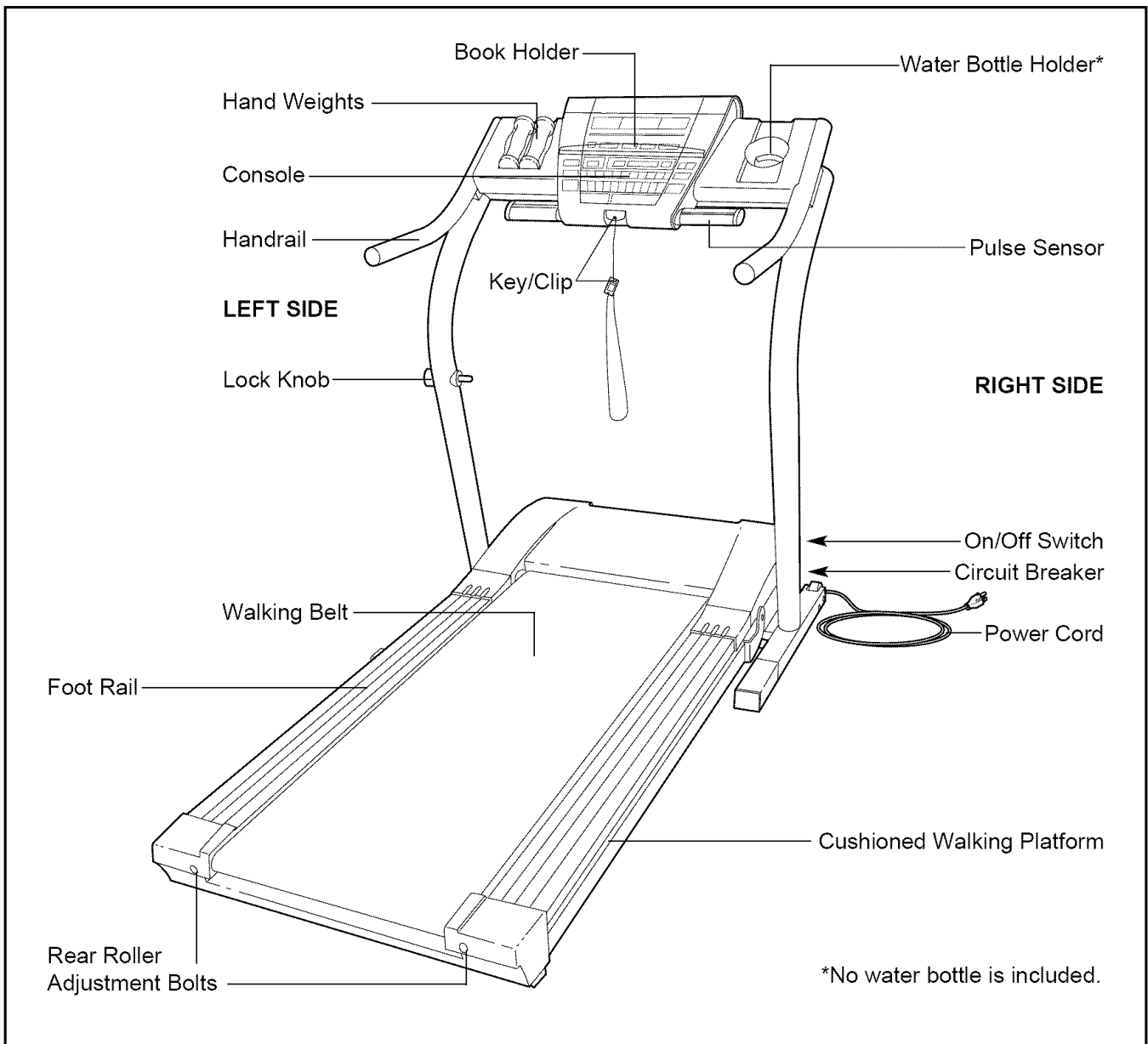

ASSEMBLY

Assembly requires two people. Set the treadmill in a cleared area and remove all packing materials. Do not dispose of the packing materials until assembly is completed. **Assembly requires the included allen wrench and your own phillips screwdriver and wire cutters** .

Note: The underside of the treadmill walking belt is coated with high-performance lubricant. During shipping, a small amount of lubricant may be transferred to the top of the walking belt or the shipping carton. This is a normal condition and does not affect treadmill performance. If there is lubricant on top of the walking belt, simply wipe off the lubricant with a soft cloth and a mild, non-abrasive cleaner.

1. With the help of a second person, carefully raise the Uprights (69) until the treadmill is in the position shown.

Insert one of the Extension Legs (102) into the treadmill as shown in the inset drawing. Make sure that the Extension Leg is turned so the Base Pad (99) is on the bottom. Note: It may be helpful to tip the Uprights (69) forward as you insert the Extension Leg.

Insert the other Extension Leg (not shown) in the same way.

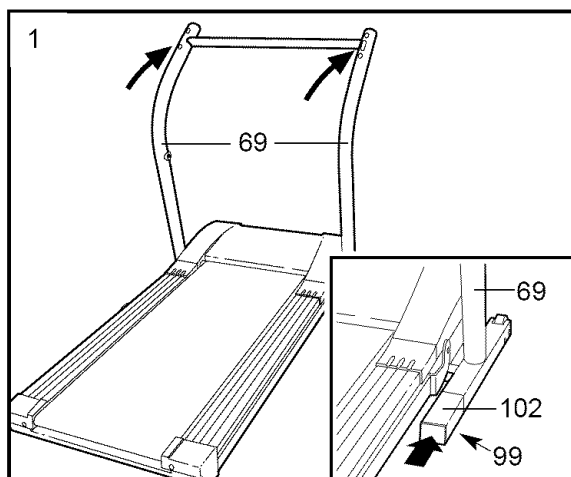

2. Press the Lock Knob Sleeve (70) into the left Upright (69).

Make sure that the Lock Pin Collar (72) and the Spring (71) are on the Lock Pin (74). Insert the Lock Pin into Lock Knob Sleeve (70) and the left Upright (69). Press the Lock Knob Spacer (117) onto the Lock Pin. Tighten the Lock Knob (68) onto the Lock Pin.

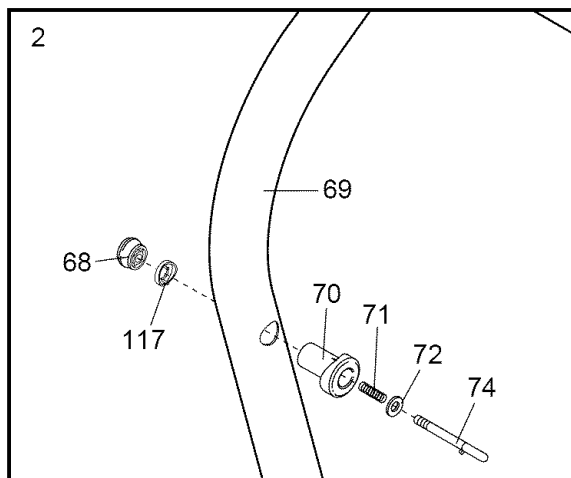

3. With the help of a second person, tip the Uprights (69) down as shown. **Make sure that the Extension Legs (102) remain in the Uprights.**

Attach each Extension Leg (102) with two Screws (100) as shown.

With the help of a second person, carefully tip the Uprights (69) back to the vertical position.

Note: A replacement Base Pad (99) may be included. Use the Base Pad to replace any Base Pad that becomes worn.

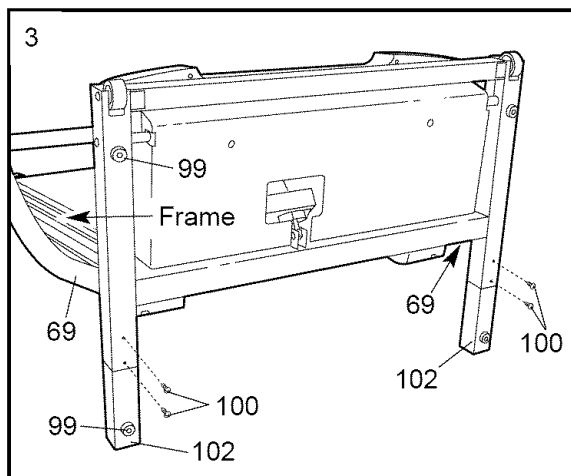

- Slide the Grounding Bracket (107) onto one of the Handrail Spacers (65) in the location shown.

See inset drawing A. Pinch the tabs on the Grounding Bracket (107) so that the tabs will fit into the hole in the Upright (69) (see inset drawing B).

See inset drawing B. Place the Handrail Spacer (65) on the left Upright (69) as shown, with the cutout on the indicated side. Note: Make sure that the tabs on the Grounding Bracket (107) (see inset drawing B) are inserted into the hole in the Upright.

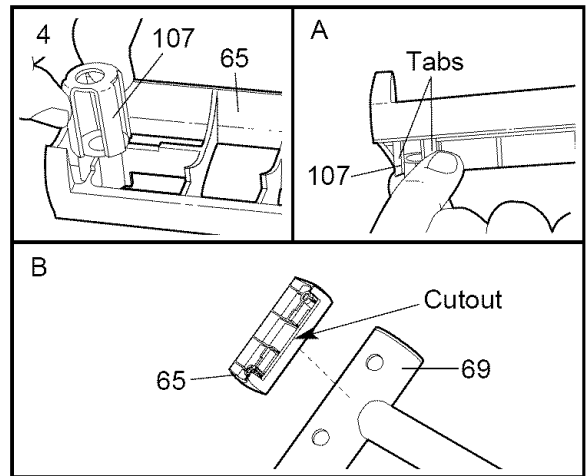

- Pull the Upright Wire Harness (98) up through the other Handrail Spacer (65). Place the Handrail Spacer on the right Upright (69) as shown, with the cutout on the indicated side (see inset drawing A).

Have a second person hold the Handrails (66) near the Uprights (69) as shown. Connect the Upright Wire Harness (98) to the wires extending from the Console Base (81). Insert the connectors and the Upright Wire Harness into the hole in the Console Base (see inset drawing B).

Set the Handrails (66) on the Spacers (65), being careful not to pinch the Upright Wire Harness (98).

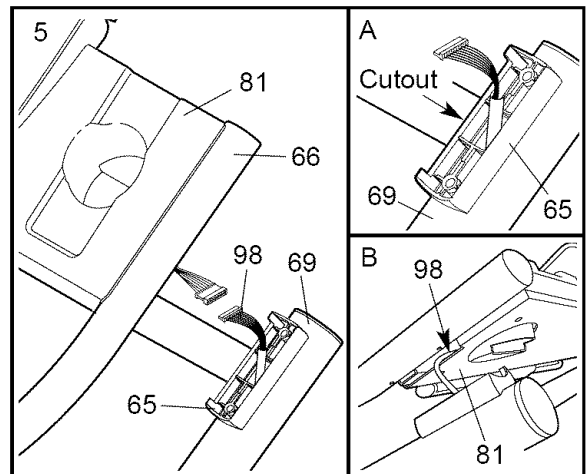

- Insert two Handrail Bolts (78) with Handrail Washers (77) and Handrail Bushings (75) into the right Upright (69) and the right Handrail Spacer (65). Turn the Handrail Bushings so they fit against the Upright with the thick sides of the Bushings toward the center of the treadmill as shown in the inset drawing. Lift the right Handrail (66) slightly and align the Bolts with the holes in the Handrail. Next, thread the Bolts into the Handrail. **Do not tighten the Bolts yet.**

Attach the left Handrail (not shown) in the same way. Tighten all four Handrail Bolts (78).

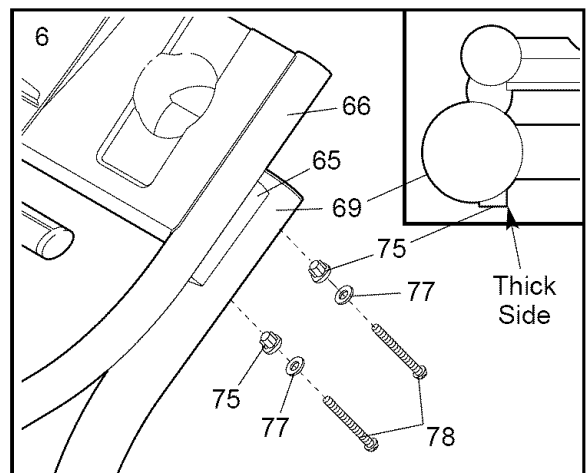

- Make sure that all parts are tightened before you use the treadmill.** Note: If there is a thin sheet of clear plastic on the face of the hood decal and the "ComforTrack" decal, remove it. Keep the included allen wrench in a secure place. The allen wrench is used to adjust the walking belt (see page 27). To protect the floor or carpet from damage, place a mat under the treadmill.

OPERATION AND ADJUSTMENT

THE PERFORMANT LUBE™ WALKING BELT

Your treadmill features a walking belt coated with PERFORMANT LUBE™, a high-performance lubricant. **IMPORTANT: Never apply silicone spray or other substances to the walking belt or the walking platform. Such substances will deteriorate the walking belt and cause excessive wear.**

HOW TO PLUG IN THE POWER CORD

⚠ DANGER: Improper connection of the equipment-grounding conductor can result in an increased risk of electric shock. Check with a qualified electrician or serviceman if you are in doubt as to whether the product is properly grounded. Do not modify the plug provided with the product—if it will not fit the outlet, have a proper outlet installed by a qualified electrician.

Your treadmill, like any other type of sophisticated electronic equipment, can be seriously damaged by sudden voltage changes in your home's power. Voltage surges, spikes, and noise interference can result from weather conditions or from other appliances being turned on or off. **To decrease the possibility of your treadmill being damaged, always use a surge suppressor with your treadmill (see drawing 1 at the right).** To purchase a surge suppressor, see your local NordicTrack dealer or call 1-800-806-3651 and order part number 146148.

Use only a single-outlet surge suppressor that is UL 1449 listed as a transient voltage surge suppressor (TVSS). The surge suppressor must have a UL suppressed voltage rating of 400 volts or less and a minimum surge dissipation of 450 joules. The surge suppressor must be electrically rated for 120 volts AC and 15 amps. There must be a monitoring light on the surge suppressor to indicate whether it is functioning properly. Failure to use a properly functioning surge suppressor could result in damage to the control system of the treadmill. If the control system is damaged, the walking belt may change speed or stop unexpectedly, which may result in a fall and serious injury.

This product must be grounded. If it should malfunction or break down, grounding provides a path of least resistance for electric current to reduce the risk of electric shock. This product is equipped with a cord having

an equipment-grounding conductor and a grounding plug. **Plug the power cord into a surge suppressor, and plug the surge suppressor into an appropriate outlet that is properly installed and grounded in accordance with all local codes and ordinances. Important: The treadmill is not compatible with GFCI-equipped outlets.**

This product is for use on a nominal 120-volt circuit, and has a grounding plug that looks like the plug illustrated in drawing 1 below. A temporary adapter that looks like the adapter illustrated in drawing 2 may be used to connect the surge suppressor to a 2-pole receptacle as shown in drawing 2 if a properly grounded outlet is not available.

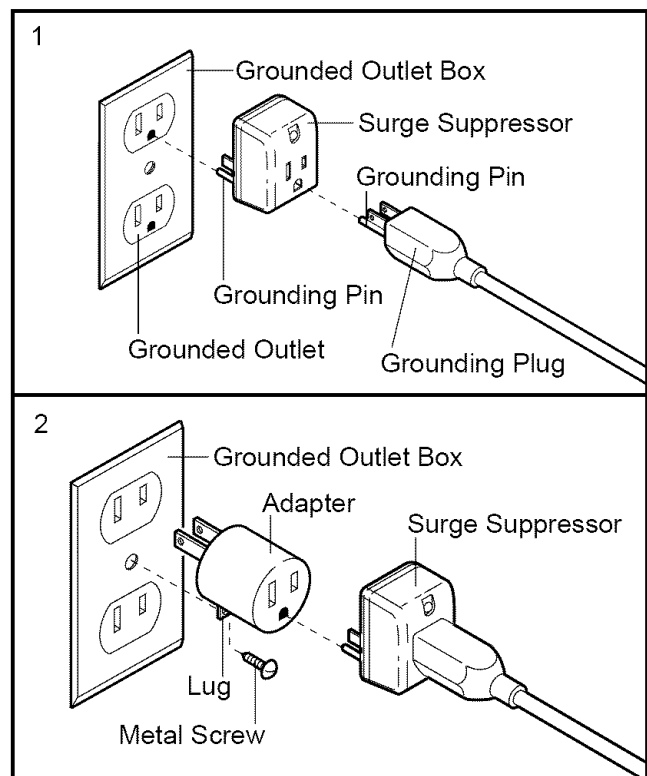

The temporary adapter should be used only until a properly grounded outlet (drawing 1) can be installed by a qualified electrician.

The green-colored rigid ear, lug, or the like extending from the adapter must be connected to a permanent ground such as a properly grounded outlet box cover. Whenever the adapter is used it must be held in place by a metal screw. **Some 2-pole receptacle outlet box covers are not grounded. Contact a qualified electrician to determine if the outlet box cover is grounded before using an adapter.**

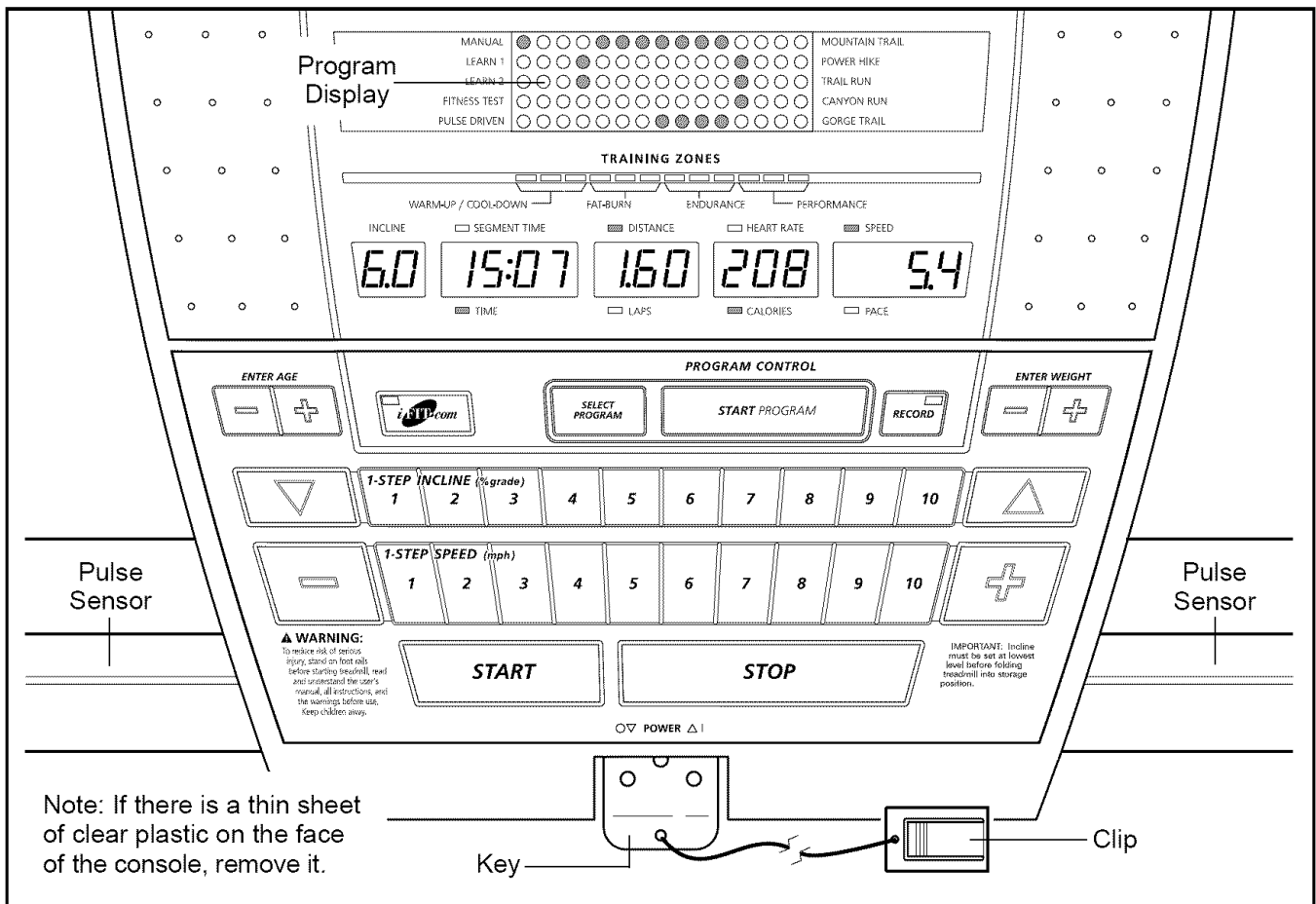

FEATURES OF THE CONSOLE

The advanced console offers an impressive selection of features to help you get the most from your exercise. When the console is in the manual mode, the speed and incline of the treadmill can be changed with a touch of a button. As you exercise, the console will provide continuous exercise feedback. You can even measure your heart rate using the built-in pulse sensor.

Five preset workout programs are also offered. Each program automatically controls the speed and incline of the treadmill to give you an effective workout. The included hand weights can be used to add upper-body exercise to your workouts as well. You can even create your own custom workout programs and store them in memory for future use.

In addition, the console offers a fitness test program that measures your relative fitness level and a pulse-driven program that automatically adjusts the speed and incline of the treadmill to keep your heart rate near a target level during your workout. Note: The fitness test program and the pulse-driven program require the use of an optional chest pulse sensor (see page 24).

The console also features new iFIT.com interactive technology. iFIT.com technology is like having a per-

sonal trainer right in your home. Using the included audio cable, you can connect the treadmill to your home stereo, portable stereo, or computer and play special iFIT.com CD programs (CDs are available separately). iFIT.com CD programs automatically control the speed and incline of the treadmill as a personal trainer guides you through every step of your workout. High-energy music provides added motivation. Each CD features two programs designed by certified personal trainers.

In addition, you can connect the treadmill to your VCR and TV and play iFIT.com video programs (videocassettes are available separately). Video programs offer the same benefits as iFIT.com CD programs, but add the excitement of working out with a class and an instructor—the hottest new trend at health clubs.

With the treadmill connected to your computer, you can also go to our Web site at www.iFIT.com and access basic programs, audio programs, and video programs directly from the internet. Additional options are soon to be available. See www.iFIT.com for details.

To purchase iFIT.com CDs or videocassettes, call toll-free 1-800-735-0768. See page 24 for information about other accessories that will help you get even more from your exercise.

⚠ CAUTION: Before operating the console, read the following precautions.

- Do not stand on the walking belt when turning on the power.
- Always wear the clip (see the drawing below) while operating the treadmill.
- Adjust the speed in small increments to avoid sudden jumps in speed.
- The pulse sensor is not a medical device. Various factors may affect the accuracy of heart rate readings. The pulse sensor is intended only as an exercise aid in determining heart rate trends in general.
- If you have heart problems, or if you are over 60 years of age and have been inactive, do not use the pulse-driven program. If you are taking medication regularly, consult your physician to find whether the medication will affect your exercise heart rate.
- Using hand weights and not holding the handrails may compromise your ability to maintain your balance. Hand weights should be used only by experienced users.
- To reduce the possibility of electric shock, keep the console dry. Avoid spilling liquids on the console and place only a sealed water bottle in the water bottle holder.

GETTING STARTED

1 Attach the clip to the waistband of your clothes.

Stand on the foot rails of the treadmill. Find the clip attached to the key and slide the clip onto the waistband of your clothes. Next, insert the key into the console.

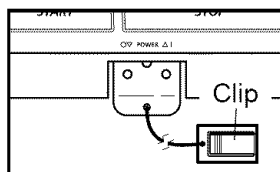

Test the clip by carefully taking a few steps backward until the key is pulled from the console. If the key is not pulled from the console, adjust the position of the clip as needed. Then, remove the key from the console.

2 Plug in the power cord.

See HOW TO PLUG IN THE POWER CORD on page 8.

3 Move the on/off switch to the on position.

Locate the on/off switch on the treadmill near the power cord. Move the on/off switch to the on position.

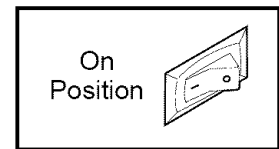

4 Insert the key fully into the console.

Stand on the foot rails of the treadmill. Make sure that the clip is securely attached to the waistband of your clothes. Next, insert the key into the console. After a moment, various displays and indicators on the console will light. Note: When the key is inserted, the treadmill incline system may automatically calibrate itself—the treadmill will rise to the highest incline level and then return to the lowest incline level.

5 Enter your weight.

Although you can use the console without entering your weight, the console will count the calories you burn more accurately if you enter your weight.

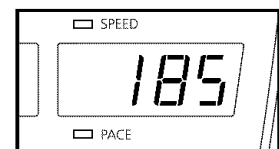

To enter your weight, press either of the Enter Weight buttons. The current weight setting will appear in the Speed/Pace display. Press the Enter Weight buttons again to enter your weight. Four seconds after the buttons are pressed, the weight setting will disappear from the display. Your weight will then be saved in memory.

To use the manual mode of the console, follow the steps beginning on page 11. To use a preset program, see page 12. To create and use a custom program, see pages 14 and 15. To use the fitness test program, see page 16. To use the pulse-driven program, see page 17. To use an iFIT.com CD or video program, refer to page 21. To use an iFIT.com program directly from our internet site, see page 23.

HOW TO USE THE MANUAL MODE

1 Insert the key fully into the console.

See GETTING STARTED on page 10.

2 Select the manual mode.

When the key is inserted, the manual mode will be selected and the Manual indicator will light. If a program has been selected, press the Select Program button repeatedly to select the manual mode.

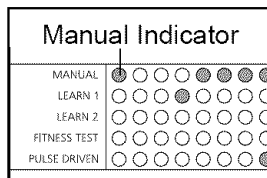

3 Press the Start button or the Speed + button to start the walking belt.

A moment after the button is pressed, the walking belt will begin to move at 1 mph. Hold the handrails and begin walking. As you exercise, change the speed of the walking belt as desired by pressing the Speed + and – buttons. Each time a button is pressed, the speed setting will change by 0.1 mph; if a button is held down, the speed setting will change in increments of 0.5 mph. To change the speed setting quickly, press the 1-step speed buttons. The speed range is 0.5 mph to 10 mph.

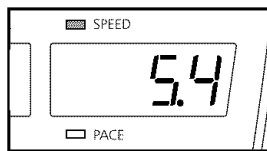

To stop the walking belt, press the Stop button. The Time display will begin to flash. To restart the walking belt, press the Start button or the Speed + button.

During the first few minutes that you use the treadmill, inspect the alignment of the walking belt, and align the walking belt if necessary (see page 27).

4 Change the incline of the treadmill as desired.

To change the incline of the treadmill, press the Incline buttons. Each time a button is pressed, the incline will change by 0.5%. To change the incline quickly, press the 1-step incline buttons. Note: After the buttons are pressed, it may take a moment for the treadmill to reach the selected incline setting.

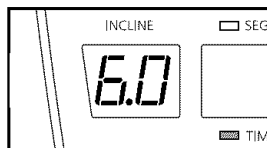

5 Follow your progress with the LED track and the displays.

The LED track—When the manual mode or an iFIT.com program is selected, the program display will show an LED track representing 1/4 mile. As you exercise, the indicators around the track will light in sequence until you have completed 1/4 mile. A new lap will then begin.

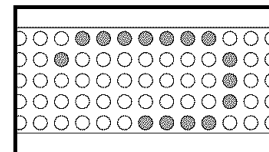

The Training Zone display—As you exercise, the Training Zone display will show the approximate intensity level of your exercise. For example, if four to six indicators in the display are lit, your intensity level is ideal for fat burning.

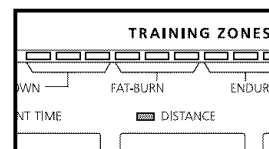

Incline display—This display shows the incline level of the treadmill.

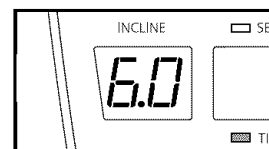

Time display—When the manual mode or an iFIT.com program is selected, this display will show the elapsed time. When a different program is selected, the display will show the time remaining in the program and the time remaining in the current segment of the program. The display will change from one number to the other every seven seconds.

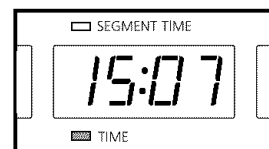

Distance/Laps display—This display shows the distance that you have walked and the number of 1/4-mile laps you have completed. The display will change from one number to the other every seven seconds.

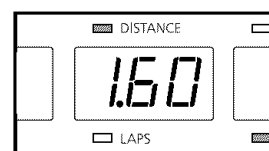

Heart Rate/Calories display—When you are not using the handgrip pulse sensor, this display will show the approximate number of calories you have burned. When you are using the handgrip pulse sensor, the display will show your heart rate (see step 6).

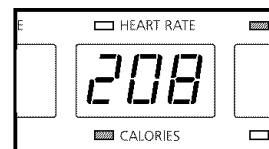

Speed/Pace display—

This display shows the speed of the walking belt and your current pace (pace is measured in minutes per mile). Every seven seconds, the display will change from one number to the other.

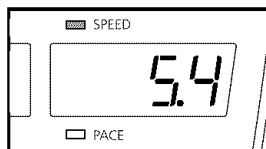

Note: The console can display speed and distance in either miles or kilometers. To find which unit of measurement is selected, hold down the Stop button while inserting the key into the console. An “E,” for English miles, or an “M,” for metric kilometers, will appear in the Speed/Pace display. Press the Speed + button to change the unit of measurement. When the desired unit of measurement is selected, remove the key and then reinsert it. Note: For simplicity, all instructions in this manual refer to miles.

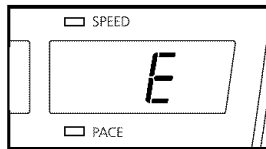

To reset the displays, press the Stop button, remove the key, and then reinsert the key.

6 Measure your heart rate, if desired.

To measure your heart rate, **stand on the foot rails** and place your hands on the metal contacts on the handrail. Your palms must be resting on the upper contacts, and your fingers must be touching the lower contacts—**avoid moving your hands**.

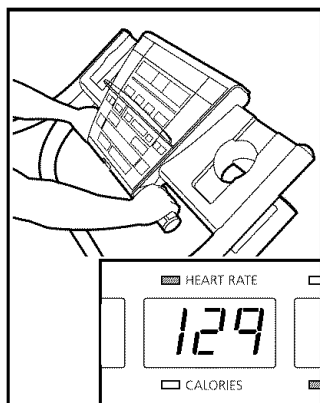

When your pulse is detected, the Heart Rate indicator will flash, three dashes (— — —) will appear in the Heart Rate/Calories display, and then your heart rate will be shown. **For the most accurate heart rate reading, continue to hold the contacts for about 15 seconds.**

7 When you are finished exercising, stop the walking belt and remove the key.

Step onto the foot rails, press the Stop button, and adjust the incline of the treadmill to 1%. **The incline must be at 1% when the treadmill is raised to the storage position or the treadmill will be damaged.** Next, remove the key from the console and put it in a secure place. **Note: If the displays and indicators on the console remain lit after the key is removed, the console is in the “demo” mode. Refer to page 24 and turn off the demo mode.**

When you are finished using the treadmill, move the on/off switch near the power cord to the off position and unplug the power cord.

HOW TO USE PRESET PROGRAMS

1 Insert the key fully into the console.

See GETTING STARTED on page 10.

2 Select one of the five preset programs.

When the key is inserted, the manual mode will be selected and the Manual indicator will light. To select

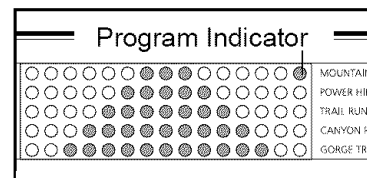

one of the preset programs, press the Select Program button repeatedly until the Mountain Trail, Power Hike, Trail Run, Canyon Run, or Gorge Trail indicator lights.

When you select a preset program, the program display will show a simplified profile of the program you have selected. For example, the profile above shows that the intensity of the selected program will gradually increase during the first half of the program, and gradually decrease during the last half. The Time display will show how long the program will last.

3 Press the Start Program button or the Speed + button to start the program.

A moment after the button is pressed, the treadmill will automatically adjust to the first speed and incline settings for the program. Hold the handrails and begin walking.

Each program is divided into several time segments of different lengths. The Time display shows both the time remaining in the program and the time remaining in the current segment. One speed setting and one incline setting are programmed for each segment. The speed setting for the first segment will be shown in the flashing Current Segment column of the program display. (The incline settings are not shown in the program display.) The speed settings for the next twelve segments will be shown in the twelve columns to the right.

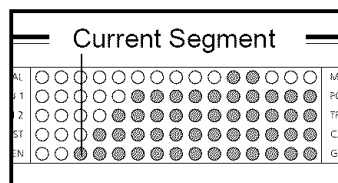

When only three seconds remain in the first segment of the program, both the Current Segment column and the column to the right will flash, a series of tones will sound, and all speed settings will move one column to the left. The speed setting for the second segment will then be shown in the flashing Current Segment column and the treadmill will automatically adjust to the speed and incline settings for the second segment.

The program will continue in this way until the speed setting for the last segment is shown in the Current Segment column and no time remains in the Time display. The walking belt will then slow to a stop.

Note: Each time a segment ends and the speed settings move to the left, if all of the indicators in the Current Segment column are lit, the speed settings may move downward so that only the highest indicators in the columns will appear in the program display. When the speed settings move to the left again and not all of the indicators in the Current Segment column are lit, the speed settings will move back up.

If the speed or incline setting for the current segment is too high or too low, you can manually override the setting by pressing the Speed or

Incline buttons on the console. Every few times one of the Speed buttons is pressed, an additional indicator will light or darken in the Current Segment column. If any of the columns to the right of the Current Segment column have the same number of lit indicators as the Current Segment column, an additional indicator may light or darken in those columns as well. Note: If you manually adjust the speed setting so that all of the indicators in the Current Segment column are lit, the speed settings in the program display will not move downward as described above. **Note: If you manually override the speed or incline setting for the current segment, when the segment ends the treadmill will automatically adjust to the speed and incline settings for the next segment.**

To stop the program temporarily, press the Stop button. The Time display will begin to flash. To restart the program, press the Start Program button or the Speed + button. To end the program, press the Stop button, remove the key, and then reinsert the key.

4 Follow your progress with the displays.

Refer to step 5 on page 11.

5 Measure your heart rate, if desired.

See step 6 on page 12.

6 When the program has ended, remove the key.

Step onto the foot rails and make sure that the incline of the treadmill is at 1%. **The incline must be at 1% when the treadmill is raised to the storage position.** Next, remove the key from the console and put it in a secure place. **Note: If the displays and indicators on the console remain lit after the key is removed, the console is in the “demo” mode. Refer to page 24 and turn off the demo mode.**

When you are finished using the treadmill, move the on/off switch near the power cord to the off position and unplug the power cord.

HOW TO CREATE CUSTOM PROGRAMS

1 Insert the key fully into the console.

See GETTING STARTED on page 10.

2 Select one of the custom programs.

When the key is inserted, the manual mode will be selected and the Manual indicator will light. To select one of the custom programs, press the Select Program button repeatedly until the Learn 1 or Learn 2 indicator lights.

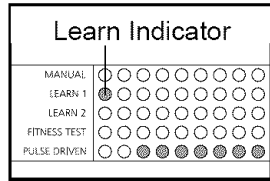

3 Press the Start Program button or the Speed + button to start the walking belt.

A moment after the button is pressed, the walking belt will begin to move. Hold the handrails and begin walking.

4 Press the Record button and program the desired speed and incline settings.

When the Record button is pressed, the indicator on the button will light. **Speed and incline settings can be programmed only when the indicator is lit.** Note: When the indicator on the Record button is lit, the Time display will show the elapsed time instead of the time remaining in the program.

Refer to the program display. Each custom program is divided into one-minute segments. One speed setting and one incline setting can be programmed for each segment. The speed setting for the first segment will be shown in the flashing Current Segment column of the program display. (The in-

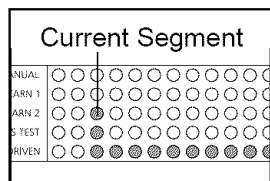

cline settings are not shown in the program display.) To program the desired speed and incline settings for the first segment, simply adjust the speed and incline of the treadmill to the desired levels with the Speed and Incline buttons. Every few times one of the Speed buttons is pressed, an additional indicator will light or darken in the Current Segment column.

When the first segment of the program is completed, the current speed setting and the current incline setting will be stored in memory. All columns in the program display will then move one column to the left and the speed setting for the second segment will be shown in the flashing Current Segment column. Program speed and incline settings for the second segment as described above.

Repeat this procedure until you have programmed speed and incline settings for as many segments as desired—custom programs can have from one to forty segments.

To stop the program temporarily, press the Stop button. All displays will pause and the Time display will begin to flash. To restart the program, press the Start Program button or the Speed + button.

5 Press the Stop button, remove the key, and then reinsert the key.

When you have programmed speed and incline settings for as many segments as desired, press the Stop button, remove the key, and then reinsert the key. The speed and incline settings that you programmed and the number of completed segments will be stored in memory. To use the custom program, see HOW TO USE CUSTOM PROGRAMS on page 15.

6 Remove the key.

See step 6 on page 13.

HOW TO USE CUSTOM PROGRAMS

1 Insert the key fully into the console.

See GETTING STARTED on page 10.

2 Select one of the custom programs.

When the key is inserted, the manual mode will be selected and the Manual indicator will light. To select one of the custom programs, press the Select Program button repeatedly until the Learn 1 or Learn 2 indicator lights.

Learn Indicator												
MANUAL	○	○	○	○	○	○	○	○	○	○	○	○
LEARN 1	●	○	○	○	○	○	○	○	○	○	○	○
LEARN 2	○	○	○	○	○	○	○	○	○	○	○	○
FITNESS TEST	○	○	○	○	○	○	○	○	○	○	○	○
PULSE DRIVEN	○	○	○	○	○	○	○	○	○	○	○	○

When a custom program is selected, the program display will show a simplified profile of the program. The Time display will show how long the program will last.

3 Press the Start Program button or the Speed + button to start the program.

A moment after the button is pressed, the treadmill will automatically adjust to the first speed and incline settings for the program. Hold the handrails and begin walking.

Each program is divided into several one-minute segments. The Time display shows both the time remaining in the program and the time remaining in the current segment.

One speed setting and one incline setting are programmed for each segment. The speed setting for the first segment will be shown in the flashing Current Segment

Current Segment												
MANUAL	○	○	○	○	○	○	○	○	○	○	○	○
LEARN 1	○	○	○	○	○	○	○	○	○	○	○	○
LEARN 2	○	○	○	○	○	○	○	○	○	○	○	○
FITNESS TEST	○	○	○	○	○	○	○	○	○	○	○	○
PULSE DRIVEN	○	○	○	○	○	○	○	○	○	○	○	○

Segment column of the program display. (The incline settings are not shown in the program display.) The speed settings for the next twelve segments will be shown in the twelve columns to the right.

When only three seconds remain in the first segment of the program, both the Current Segment column and the column to the right will flash, a series of tones will sound, and all speed settings will move one column to the left. The speed setting for the second segment will then be shown in the flashing Current Segment column and the treadmill will automatically adjust to the speed and incline settings that you programmed previously.

The program will continue until the speed setting for the last segment is shown in the Current Segment column and no time remains in the Time display. The walking belt will then slow to a stop.

Note: If the program is too easy or too difficult, the speed or incline setting for the current segment can be adjusted with the Speed or Incline buttons.

Adjustments will not be stored in memory. To **reprogram** the speed or incline setting for the current segment, press the Record button. The indicator on the button will light. **Speed and incline settings can be programmed only when the indicator is lit.** (Note: When the indicator on the Record button is lit, the Time display will show the elapsed time instead of the time remaining in the program.) Adjust the speed or incline setting for the current segment with the Speed or Incline buttons. After the segment is completed, press the Record button again. The new setting will be stored in memory.

To stop the program temporarily, press the Stop button. All displays will pause and the Time display will begin to flash. To restart the program, press the Start Program button or the Speed + button. To end the program, press the Stop button, remove the key, and then reinsert the key.

4 Follow your progress with the displays.

Refer to step 5 on page 11.

5 Measure your heart rate, if desired.

See step 6 on page 12.

6 When the program has ended, remove the key.

See step 6 on page 13.

HOW TO USE THE FITNESS TEST PROGRAM

The fitness test program is designed to measure your relative fitness level. For the best results, the fitness test program should be used at a time when your energy level is high; the fitness test program should not be used if you have already exercised during the day.

Note: You must wear the optional chest pulse sensor to use the fitness test program (see page 24).

Follow the steps below to use the fitness test program.

1 Put on the chest pulse sensor.

Refer to the instructions included with the chest pulse sensor to put on the chest pulse sensor. Note: The fitness test program will automatically stop if your heart rate is not detected 4 minutes after the program is started.

2 Insert the key fully into the console.

See GETTING STARTED on page 10.

3 Select the fitness test program.

When the key is inserted, the manual mode will be selected and the Manual indicator will light. To select the fitness test program, press the Select

Program button repeatedly until the Fitness Test indicator lights. When you select the fitness test program, the program display will show a simplified profile of the program.

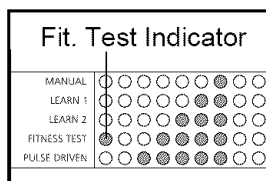

4 Enter your age.

When the fitness test program is selected, an age setting will flash in the Incline display and the letters "AGE" will appear in the Time display. You must enter your age to use the fitness test program. If you have already entered your age, go to step 5. If you have not entered your age, press the Enter Age buttons to enter your age. Four seconds after the buttons are pressed, the age setting will disappear from the display. Your age will then be saved in memory.

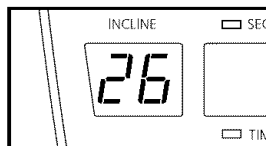

5 Press the Start Program button or the Speed + button to start the program.

When the button is pressed, the Distance/Laps display will show an "L 1" (level 1), indicating that the first 4-minute segment of the fitness test program has begun. The incline of the treadmill will automatically adjust to 3% and the walking belt will begin to move at 1.5 mph. Hold the handrails and begin walking.

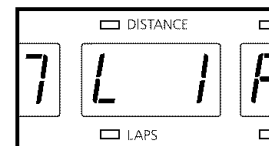

The fitness test program consists of seven 4-minute segments and is followed by a 2-minute cool-down segment. One speed setting and one incline setting are programmed for each segment. The speed setting for the first segment will be shown in the flashing Current Segment column of the program display.

(The incline settings are not shown in the program display.) The speed settings for the remaining seven segments will be shown in the seven columns to the right.

Current Segment							
MANUAL	○	○	○	○	○	○	○
LEARN 1	○	○	○	○	○	○	○
LEARN 2	○	○	○	○	○	○	○
TEST	○	○	○	○	○	○	○
DRIVEN	○	○	○	○	○	○	○

When the first 4-minute segment of the fitness test program is completed, all speed settings will move one column to the left and the Distance/Laps display will show an "L 2," indicating that the second 4-minute segment has begun. The incline will then adjust to 4% and the speed will increase to 2.5 mph. When the second 4-minute segment is completed, the speed settings will again move one column to the left and the Distance/Laps display will show an "L 3." The incline will remain the same, but the speed will then increase to 3.3 mph. At the beginning of each 4-minute segment, the speed and/or incline of the treadmill will automatically increase. The fitness test program will continue in this way until your heart rate reaches 70% of your estimated maximum heart rate, and the current 4-minute segment is completed. The fitness test program will then be completed, regardless of how many segments remain.

When the fitness test program is completed, the letter "C" will appear in the Distance/Laps display, indicating that the 2-minute cool-down segment has begun. The incline will then adjust to 1% and the speed will decrease to 1.2 mph.

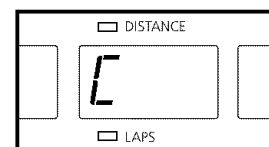

When the cool-down segment is completed, the walking belt will slow to a stop. After the fitness test program is completed, your fitness level will be shown in the Time display. There are ten fitness levels—fitness level 10 (FL:10) is the highest. Remember, the fitness program is intended only to indicate your relative fitness level.

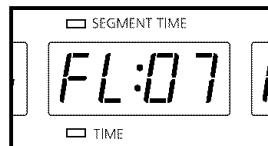

Note: The Speed and Incline buttons will not function while the fitness test program is selected. If your pulse is not detected during the program, the letters “PLS” will flash in the Heart Rate/Calories display. If your pulse is not detected during the last thirty seconds of any 4-minute segment (after 4 minutes, after 8 minutes, etc.), the fitness test program will end and the Time display will show a fitness level of 0 (FL: 0).

The fitness test program cannot be stopped temporarily and then restarted. However, the program can be stopped at any time by pressing the Stop button. The Time display will then show an estimated fitness level.

6 When the program has ended, remove the key.

Step onto the foot rails and make sure that the incline of the treadmill is at 1%. **The incline must be at 1% when the treadmill is raised to the storage position.** Next, remove the key from the console and put it in a secure place. **Note: If the displays and indicators on the console remain lit after the key is removed, the console is in the “demo” mode. Refer to page 24 and turn off the demo mode.**

When you are finished using the treadmill, move the on/off switch near the power cord to the off position and unplug the power cord.

HOW TO USE THE PULSE-DRIVEN PROGRAM

The pulse-driven program automatically adjusts the speed and incline of the treadmill to keep your heart rate near a target level during your workout. **Note: You must wear the optional chest pulse sensor to use the pulse-driven program (see page 24).**

CAUTION: If you have heart problems, or if you are over 60 years of age and have been inactive, do not use the pulse-driven program. If you are taking medication regularly, consult your physician to find whether the medication will affect your exercise heart rate.

Follow the steps below to use the pulse-driven program.

1 Put on the chest pulse sensor.

Refer to the instructions included with the chest pulse sensor to put on the chest pulse sensor.

2 Insert the key fully into the console.

See GETTING STARTED on page 10.

3 Select the pulse-driven program.

When the key is inserted, the manual mode will be selected and the Manual indicator will light. To select the pulse-driven program, press the Select Program button repeatedly until the Pulse Driven indicator lights. When the pulse-driven program is selected, the program display will show a simplified profile of the program.

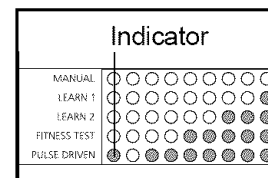

4 Enter your age.

When the pulse-driven program is selected, an age setting will flash in the Incline display and the letters “AGE” will appear in the Time display.

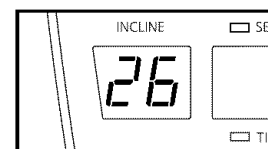

You must enter your age to use the pulse-driven program. If you have already entered your age, go to step 5. If you have not entered your age, press the Enter Age buttons to enter your age. Four seconds after the buttons are pressed, the age setting will disappear from the display. Your age will then be saved in memory.

5 Press the Start Program button or the Speed + button to start the program.

A moment after the button is pressed, the treadmill will automatically adjust to the first speed and incline settings for the program. Hold the handrails and begin walking.

Each program is divided into several time segments of different lengths. The Time display will show both the time remaining in the program and the time remaining in the current segment. One target heart rate setting is programmed for each segment.

The heart rate setting for the first segment will be shown in the flashing Current Segment column of the program display.

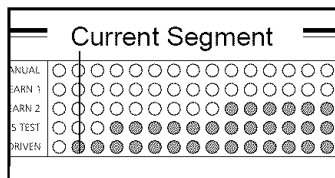

The heart rate settings for the next twelve segments will be shown in the twelve columns to the right.

When only three seconds remain in the first segment of the program, both the Current Segment column and the column to the right will flash, a series of tones will sound, and all heart rate settings will move one column to the left. The heart rate setting for the second segment will then be shown in the flashing Current Segment column. As you exercise, the speed and/or incline of the treadmill will automatically change as needed to keep your heart rate near the current target heart rate setting.

The program will continue until no time remains in the Time display. The walking belt will then slow to a stop.

If the speed or incline setting for the current segment is too high or too low, you can adjust the setting with the Speed or Incline buttons. However, if you decrease the speed, the incline will automatically increase; if you increase the speed, the incline will decrease. If you increase the incline, the speed will decrease; if you decrease the incline, the speed will increase. The treadmill will always attempt to keep your heart rate near the target heart rate setting for the current segment. Note: When the incline reaches the lowest setting, the speed cannot be increased any further. When the incline reaches the highest setting, the speed cannot be decreased any further.

If your heart rate is not detected during the program, the speed and incline of the treadmill may automatically decrease until your heart rate is detected. If this occurs, refer to the instructions included with the optional chest pulse sensor.

To stop the program, press the Stop button. The Time display will begin to flash. The pulse-driven program should not be stopped temporarily and then restarted. To use the pulse-driven program again, reselect the program and start it at the beginning.

6 Follow your progress with the displays.

Refer to step 5 on page 11.

7 When the program has ended, remove the key.

See step 6 on page 13.

HOW TO CONNECT THE TREADMILL TO YOUR CD PLAYER, VCR, OR COMPUTER

To use iFIT.com CDs, the treadmill must be connected to your portable CD player, portable stereo, home stereo, or computer with CD player. See pages 19 and 20 for connecting instructions. To use iFIT.com videocassettes, the treadmill must be connected to your VCR. See page 21 for connecting instructions. To use iFIT.com programs directly from our internet site, the treadmill must be connected to your home computer. See page 20 for connecting instructions.

HOW TO CONNECT YOUR PORTABLE CD PLAYER

Note: If your CD player has separate LINE OUT and PHONES jacks, see instruction A below. If your CD player has only one jack, see instruction B.

- A. Plug one end of the audio cable into the jack on the front of the treadmill near the power cord. Plug the other end of the cable into the LINE OUT jack on your CD player. Plug your headphones into the PHONES jack.

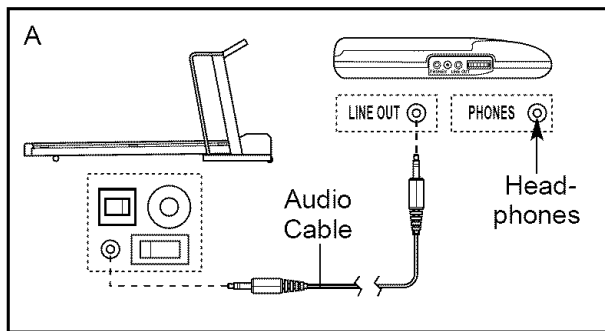

- B. Plug one end of the audio cable into the jack on the front of the treadmill near the power cord. Plug the other end of the cable into a 3.5mm Y-adapter (available at electronics stores). Plug the Y-adapter into the PHONES jack on your CD player. Plug your headphones into the other side of the Y-adapter.

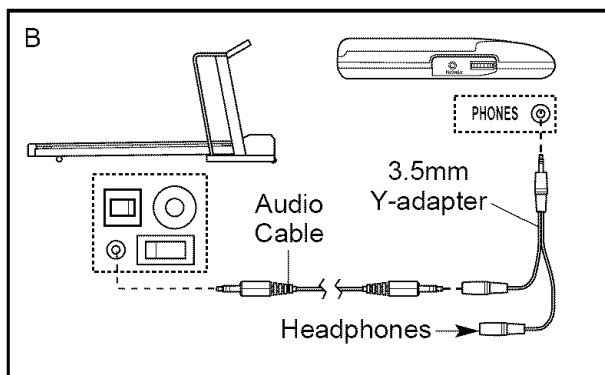

HOW TO CONNECT YOUR PORTABLE STEREO

Note: If your stereo has an RCA-type AUDIO OUT jack, see instruction A below. If your stereo has a 3.5mm LINE OUT jack, see instruction B. If your stereo has only a PHONES jack, see instruction C.

- A. Plug one end of the audio cable into the jack on the front of the treadmill near the power cord. Plug the other end of the cable into the included adapter. Plug the adapter into an AUDIO OUT jack on your stereo.

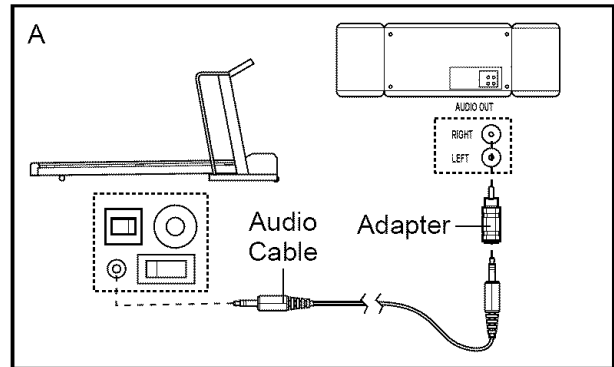

- B. Plug one end of the audio cable into the jack on the front of the treadmill near the power cord. Plug the other end of the cable into the LINE OUT jack on your stereo.

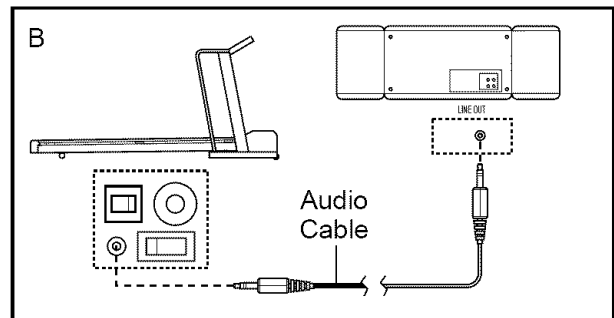

- C. Plug one end of the audio cable into the jack on the front of the treadmill near the power cord. Plug the other end of the cable into a 3.5mm Y-adapter (available at electronics stores). Plug the Y-adapter into the PHONES jack on your stereo. Plug your headphones into the other side of the Y-adapter.

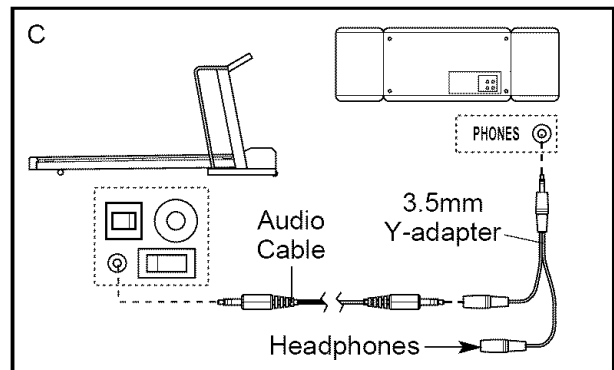

HOW TO CONNECT YOUR HOME STEREO

Note: If your stereo has an unused **LINE OUT** jack, see instruction **A** below. If the **LINE OUT** jack is being used, see instruction **B**.

- A. Plug one end of the audio cable into the jack on the front of the treadmill near the power cord. Plug the other end of the cable into the included adapter. Plug the adapter into the **LINE OUT** jack on your stereo.

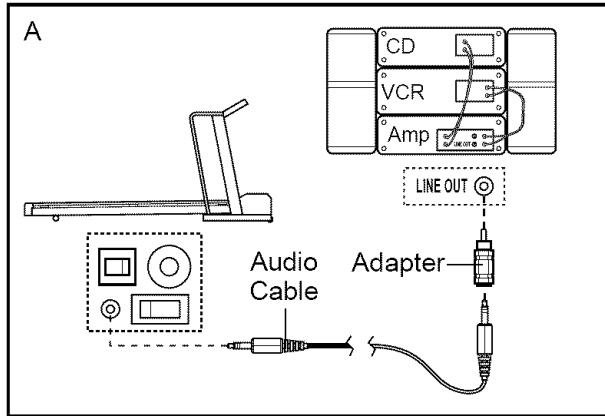

- B. Plug one end of the audio cable into the jack on the front of the treadmill near the power cord. Plug the other end of the cable into the included adapter. Plug the adapter into an **RCA Y-adapter** (available at electronics stores). Next, remove the wire that is currently plugged into the **LINE OUT** jack on your stereo and plug the wire into the unused side of the **RCA Y-adapter**. Plug the **RCA Y-adapter** into the **LINE OUT** jack on your stereo.

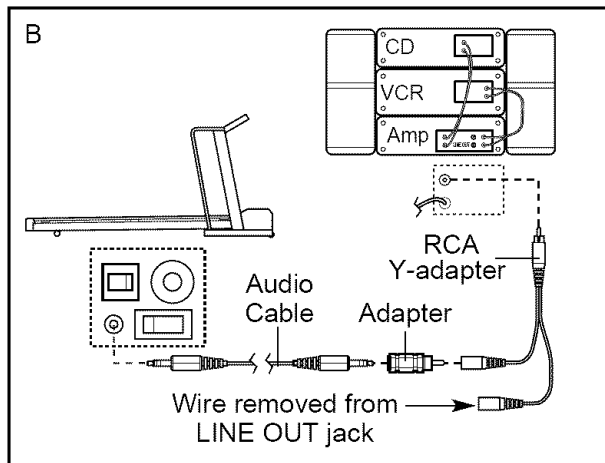

HOW TO CONNECT YOUR COMPUTER

Note: If your computer has a **3.5mm LINE OUT** jack, see instruction **A**. If your computer has only a **PHONES** jack, see instruction **B**.

- A. Plug one end of the audio cable into the jack on the front of the treadmill near the power cord. Plug the other end of the cable into the **LINE OUT** jack on your computer.

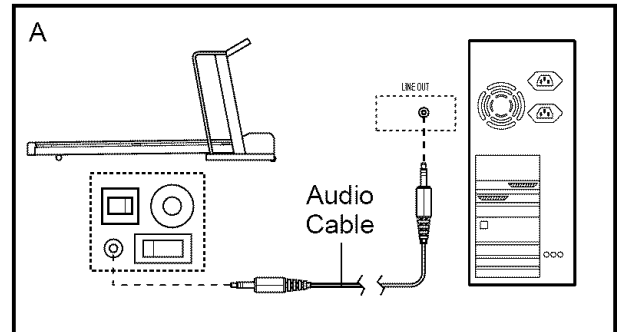

- B. Plug one end of the audio cable into the jack on the front of the treadmill near the power cord. Plug the other end of the cable into a **3.5mm Y-adapter** (available at electronics stores). Plug the **Y-adapter** into the **PHONES** jack on your computer. Plug your headphones or speakers into the other side of the **Y-adapter**.

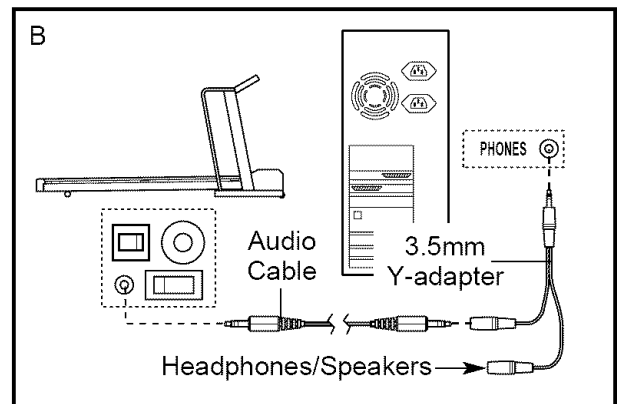

HOW TO CONNECT YOUR VCR

Note: If your VCR has an unused AUDIO OUT jack, see instruction A below. If the AUDIO OUT jack is being used, see instruction B. If you have a TV with a built-in VCR, see instruction B. If your VCR is connected to your home stereo, see **HOW TO CONNECT YOUR HOME STEREO** on page 20.

- A. Plug one end of the audio cable into the jack on the front of the treadmill near the power cord. Plug the other end of the cable into the included adapter. Plug the adapter into the AUDIO OUT jack on your VCR.

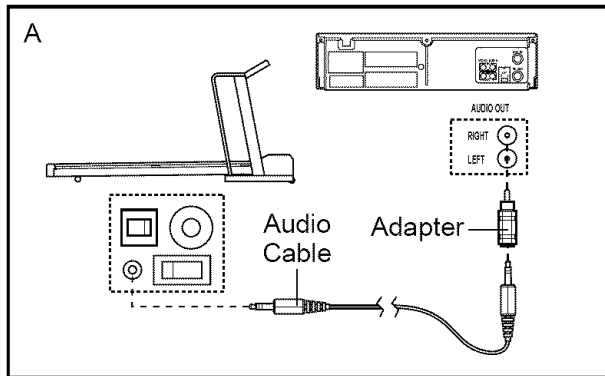

- B. Plug one end of the audio cable into the jack on the front of the treadmill near the power cord. Plug the other end of the cable into the included adapter. Plug the adapter into an RCA adapter (available at electronics stores). Next, remove the wire that is currently plugged into the AUDIO OUT jack on your VCR and plug the wire into the unused side of the RCA adapter. Plug the RCA adapter into the AUDIO OUT jack on your VCR.

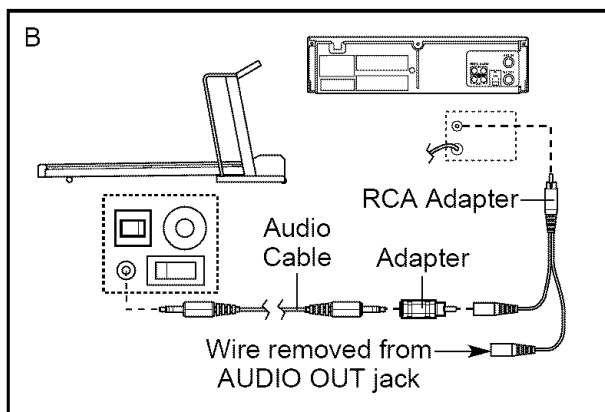

HOW TO USE iFIT.COM CD AND VIDEO PROGRAMS

To use iFIT.com CDs or videocassettes, the treadmill must be connected to your portable CD player, portable stereo, home stereo, computer with CD player, or VCR. See **HOW TO CONNECT THE TREADMILL TO YOUR CD PLAYER, VCR, OR COMPUTER** on page 19. **Note:** To purchase iFIT.com CDs or videocassettes, call toll-free 1-800-735-0768.

Follow the steps below to use an iFIT.com CD or video program.

1 Insert the key fully into the console.

See **GETTING STARTED** on page 10.

2 Select the iFIT.com mode.

When the key is inserted, the manual mode will be selected and the Manual indicator will light. To use an iFIT.com CD or video program, press the iFIT.com button or press the Select Program button repeatedly until the indicator on the iFIT.com button lights.



3 Insert the iFIT.com CD or videocassette.

If you are using an iFIT.com CD, insert the CD into your CD player. If you are using an iFIT.com videocassette, insert the videocassette into your VCR.

4 Press the PLAY button on your CD player or VCR.

A moment after the button is pressed, your personal trainer will begin guiding you through your workout. Simply follow your personal trainer's instructions. **Note:** If the Time display is flashing, press the Start button or the Speed Δ button on the console. The treadmill will not respond to a CD or video program when the Time display is flashing.

During the CD or video program, an electronic "chirping" sound will alert you when the speed and/or incline of the treadmill is about to change. **CAUTION: Always listen for the "chirp" and be prepared for speed and/or incline changes. In some instances, the speed and/or incline may change before the personal trainer describes the change.**

If the speed or incline settings are too high or too low, you can manually override the settings at any time by pressing the Speed or Incline buttons on the console. However, **when the next “chirp” is heard, the speed and/or incline will change to the next settings of the CD or video program.**

To stop the walking belt at any time, press the Stop button on the console. The Time display will begin to flash. To restart the program, press the Start Program button or the Speed + button. After a moment, the walking belt will begin to move at 1.0 mph. **When the next “chirp” is heard, the speed and incline will change to the next settings of the CD or video program.**

When the CD or video program is completed, the walking belt will stop and the Time display will begin to flash. Note: To use another CD or video program, press the Stop button or remove the key and go to step 1 on page 18.

Note: If the speed or incline of the treadmill does not change when a “chirp” is heard:

- **make sure that the iFIT.com indicator is lit and that the Time display is not flashing. If the Time display is flashing, press the Start button or the Speed Δ button on the console**
- **adjust the volume of your CD player or VCR. If the volume is too high or too low, the console may not detect the program signals**

- **make sure that the audio cable is properly connected, that it is fully plugged in, and that it is not wrapped around a power cord**
- **if you are using your portable CD player and the CD skips, set the CD player on the floor or another flat surface instead of on the console.**
- **See the bottom of page 27.**

5 Follow your progress with the LED track and the displays.

See step 5 on page 11.

6 Measure your heart rate, if desired.

Refer to step 6 on page 12.

7 When the program has ended, remove the key.

See step 6 on page 13.

CAUTION: Always remove iFIT.com CDs and videocassettes from your CD player or VCR when you are finished using them.

HOW TO USE PROGRAMS DIRECTLY FROM OUR INTERNET SITE

Our Web site at www.iFIT.com allows you to access basic programs, audio programs, and video programs directly from the internet. Additional options are soon to be available. See www.iFIT.com for details.

To use programs from our Web site, the treadmill must be connected to your home computer. See HOW TO CONNECT YOUR COMPUTER on page 20. In addition, you must have an internet connection and an internet service provider. A list of specific system requirements will be found on our Web site.

Follow the steps below to use a program from our Web site.

1 Insert the key fully into the console.

See GETTING STARTED on page 10.

2 Select the iFIT.com mode.

When the key is inserted, the manual mode will be selected and the Manual indicator will light. To use a program from our internet site, press the iFIT.com button or press the Select Program button repeatedly until the indicator on the iFIT.com button lights.

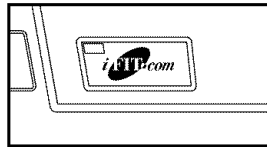

3 Go to your computer and start an internet connection.

4 Start your web browser, if necessary, and go to our internet site at www.iFIT.com.

5 Follow the desired links on our internet site to select a program.

Read and follow the on-line instructions for using a program.

6 Follow the on-line instructions to start the program.

When you start the program, an on-screen countdown will begin.

7 Return to the treadmill and stand on the foot rails. Find the clip attached to the key and slide the clip onto the waistband of your clothing.

When the on-screen countdown ends, the program will begin and the walking belt will begin to move. Hold the handrails, step onto the walking belt, and begin walking. During the program, an electronic “chirping” sound will alert you when the speed and/or incline of the treadmill is about to change. **CAUTION: Always listen for the “chirp” and be prepared for speed and/or incline changes.**

If the speed or incline settings are too high or too low, you can manually override the settings at any time by pressing the Speed or Incline buttons on the console. **However, when the next “chirp” is heard, the speed and/or incline will change to the next settings of the program.**

To stop the walking belt at any time, press the Stop button on the console. The Time display will begin to flash. To restart the program, press the Start Program button or the Speed + button. After a moment, the walking belt will begin to move at 1.0 mph. **When the next “chirp” is heard, the speed and incline will change to the next settings of the program.**

When the program is completed, the walking belt will stop and the Time display will begin to flash. Note: To use another program, press the Stop button and go to step 5.

Note: If the speed or incline of the treadmill does not change when a “chirp” is heard, make sure that the iFIT.com indicator is lit and that the Time display is not flashing. In addition, make sure that the audio cable is properly connected, that it is fully plugged in, and that it is not wrapped around a power cord.

8 Follow your progress with the LED track and the displays.

See step 5 on page 11.

9 When the program has ended, remove the key.

See step 6 on page 13.

THE INFORMATION MODE/DEMO MODE

The console features an information mode that keeps track of the total number of hours that the treadmill has been operated and the total number of miles that the walking belt has moved. The information mode also allows you to switch the console from miles per hour to kilometers per hour. In addition, the information mode allows you to turn on and turn off the demo mode.

To select the information mode, hold down the Stop button while inserting the key into the console. When the information mode is selected, the following information will be shown:

The Time display will show the total number of hours that the treadmill has been used.

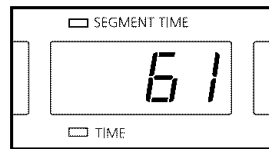

The Distance/Laps display will show the total number of miles that the walking belt has moved.

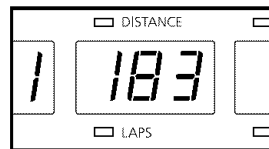

An "E," for English miles, or an "M," for metric kilometers, will appear in the Speed/Pace display. Press the Speed + button to change the unit of measurement.

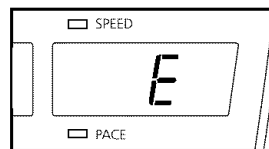

IMPORTANT: The Heart Rate/Calories display should be blank. If a "d" appears in the display, the console is in the "demo" mode.

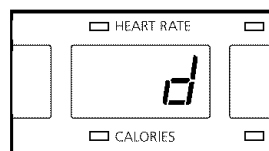

This mode is intended to be used only when a treadmill is displayed in a store. When the console is in the demo mode, the power cord can be plugged in, the key can be removed from the console, and the displays and indicators on the console will automatically light in a preset sequence, although the buttons on the console will not operate. **If a "d" appears in the Heart Rate/Calories display when the information mode is selected, press the Speed - button so the Heart Rate/Calories display is blank.**

To exit the information mode, remove the key from the console.

THE OPTIONAL CHEST PULSE SENSOR

An optional chest pulse sensor adds even more features to the console. The chest pulse sensor provides hands-free operation and continuously monitors your heart rate during your workouts. **To purchase the optional chest pulse sensor, call toll-free 1-800-734-2377.**

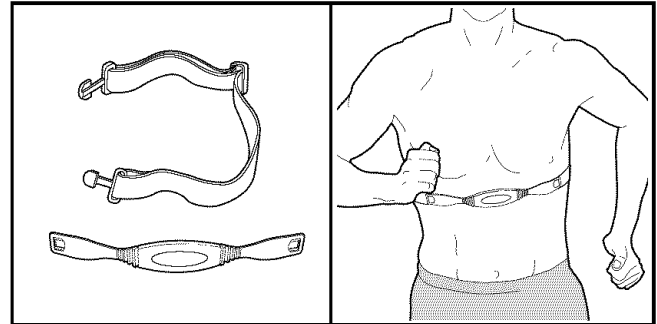

HOW TO FOLD AND MOVE THE TREADMILL

HOW TO FOLD THE TREADMILL FOR STORAGE

Before folding the treadmill, adjust the incline to the lowest position. If this is not done, the treadmill may be permanently damaged. Remove the key and unplug the power cord. **CAUTION: You must be able to safely lift 45 pounds (20 kg) in order to raise, lower, or move the treadmill.**

1. Hold the treadmill with your hands in the locations shown at the right. **CAUTION: To decrease the possibility of injury, bend your legs and keep your back straight. As you raise the treadmill, make sure to lift with your legs rather than your back.** Raise the treadmill about halfway to the vertical position.

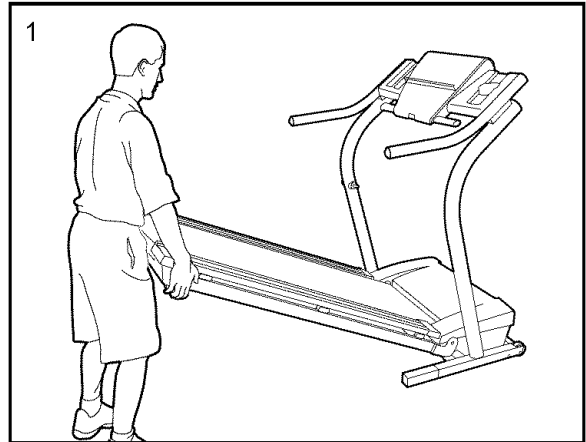

2. Move your right hand to the position shown and hold the treadmill firmly. Using your left hand, pull the latch knob to the left and hold it. Raise the treadmill until the latch pin is aligned with the hole in the catch. Insert the latch pin into the catch. **Make sure that the latch pin is fully inserted into the catch.**

To protect the floor or carpet from damage, place a mat under the treadmill. Keep the treadmill out of direct sunlight. Do not leave the treadmill in the storage position in temperatures above 85° Fahrenheit.

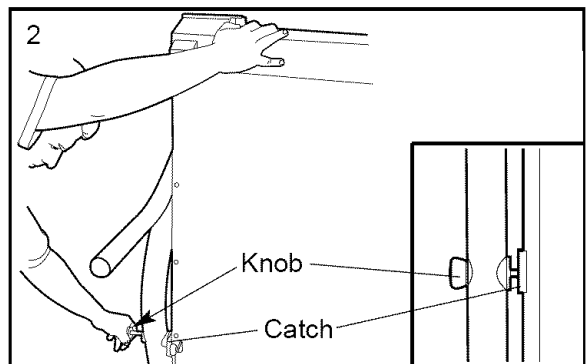

HOW TO MOVE THE TREADMILL

Before moving the treadmill, convert the treadmill to the storage position as described above. **Make sure that the pin on the lock knob is inserted into the slot in the catch.**

1. Hold the handrails as shown and place one foot against a wheel.
2. Tilt the treadmill back until it rolls freely on the front wheels. Carefully move the treadmill to the desired location. **Never move the treadmill without tipping it back. To reduce the risk of injury, use extreme caution while moving the treadmill. Do not attempt to move the treadmill over an uneven surface.**
3. Place one foot on the base, and carefully lower the treadmill until it is resting in the storage position.

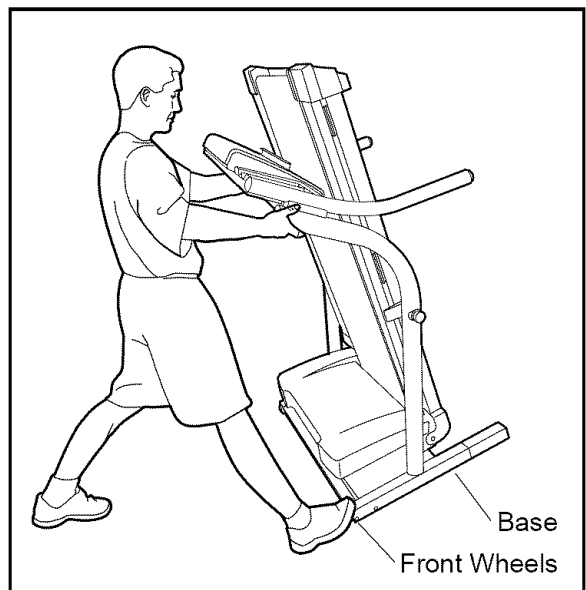

HOW TO LOWER THE TREADMILL FOR USE

1. Refer to drawing 2 above. Hold the upper end of the treadmill with your right hand as shown. Using your left hand, pull the lock knob to the left and hold it. Pivot the treadmill down until the frame is past the pin on the lock knob.
2. Refer to drawing 1 above. Hold the treadmill firmly with both hands, and lower the treadmill to the floor. **Do not drop the treadmill frame to the floor. CAUTION: To decrease the possibility of injury, bend your legs and keep your back straight.**

TROUBLE-SHOOTING

Most treadmill problems can be solved by following the steps below. Find the symptom that applies, and follow the steps listed. If further assistance is needed, please call our Customer Service Department toll-free at 1-888-825-2588, Monday through Friday, 6 a.m. until 6 p.m. Mountain Time (excluding holidays).

PROBLEM: The power does not turn on

SOLUTION: a. Make sure that the power cord is plugged into a surge suppressor, and that the surge suppressor is plugged into a properly grounded outlet (see page 8). Use only a single-outlet surge suppressor that meets all of the specifications described on page 8. Important: The treadmill is not compatible with GFCI-equipped outlets.

b. After the power cord has been plugged in, make sure that the key is fully inserted into the console.

c. Check the circuit breaker located on the treadmill near the power cord. If the switch protrudes as shown, the circuit breaker has tripped. To reset the circuit breaker, wait for five minutes and then press the switch back in.

d. Check the on/off switch located on the treadmill near the power cord. The switch must be in the on position.

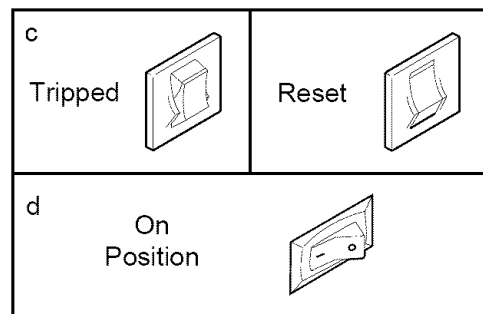

PROBLEM: The power turns off during use

SOLUTION: a. Check the circuit breaker located on the treadmill frame near the power cord (see c. above). If the circuit breaker has tripped, wait for five minutes and then press the switch back in.

b. Make sure that the power cord is plugged in.

c. Unplug the power cord, wait for five minutes, and then plug the power cord back in.

d. Remove the key from the console. Reinsert the key fully into the console.

e. Make sure that the on/off switch is in the on position.

f. If the treadmill still will not run, please call our Customer Service Department, toll-free.

PROBLEM: The displays of the console do not function properly

SOLUTION: a. Remove the key from the console and **unplug the power cord**. Carefully tip the treadmill down as shown in drawing a. Remove the Screws (39, 83) from the hood. Raise the Uprights (69) and carefully remove the hood.

Locate the Reed Switch (10) and the Magnet (7) on the left side of the Pulley (8). Turn the Pulley until the Magnet is aligned with the Reed Switch. **Make sure that the gap between the Magnet and the Reed Switch is about 1/8"**. If necessary, loosen the Screw (100), move the Reed Switch slightly, and then retighten the Screw. Re-attach the hood, and run the treadmill for a few minutes to check for a correct speed reading.

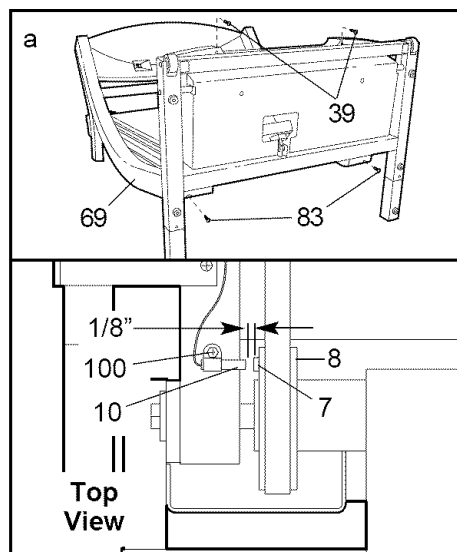

PROBLEM: The walking belt slows when walked on

SOLUTION: a. Use only a single-outlet surge suppressor that meets all of the specifications described on page 8.

b. If the walking belt is overtightened, treadmill performance may decrease and the walking belt may become damaged. Remove the key and **UNPLUG THE POWER CORD**. Using the allen wrench, turn both rear roller adjustment bolts counterclockwise, 1/4 of a turn. When the walking belt is properly tightened, you should be able to lift each side of the walking belt 3 to 4 inches off the walking platform. Be careful to keep the walking belt centered. Plug in the power cord, insert the key and run the treadmill for a few minutes. Repeat until the walking belt is properly tightened.

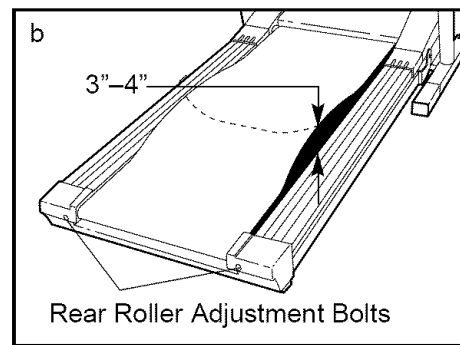

c. If the walking belt still slows when walked on, please call our Customer Service Department, toll-free.

PROBLEM: The walking belt is off-center or slips when walked on

SOLUTION: a. **If the walking belt has shifted to the left**, first remove the key and **UNPLUG THE POWER CORD**. Using the allen wrench, turn the left rear roller bolt clockwise 1/2 of a turn. Be careful not to overtighten the walking belt. **If the walking belt has shifted to the right**, turn the left rear roller bolt counterclockwise 1/2 of a turn. Plug in the power cord, insert the key and run the treadmill for a few minutes. Repeat until the walking belt is centered.

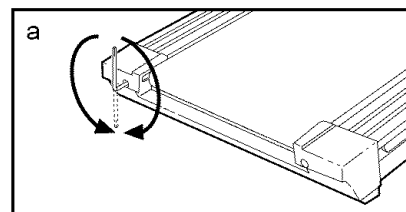

b. If the walking belt slips when walked on, first remove the key and **UNPLUG THE POWER CORD**. Using the allen wrench, turn both rear roller bolts clockwise, 1/4 of a turn. When the walking belt is correctly tightened, you should be able to lift each side of the walking belt 3 to 4 inches off the walking platform. Be careful to keep the walking belt centered. Plug in the power cord, insert the key and carefully walk on the treadmill for a few minutes. Repeat until the walking belt is properly tightened.

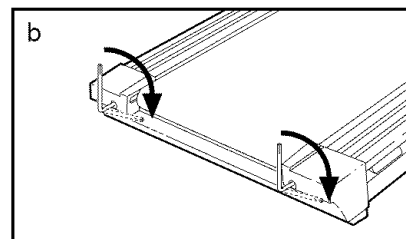

PROBLEM: The incline of the treadmill does not change correctly or does not change when iFIT.com CDs and videos are played

SOLUTION: a. With the key in the console, press one of the incline buttons. **While the incline is changing, remove the key.** After a few seconds, re-insert the key. The treadmill will automatically rise to the maximum incline level and then return to the minimum level. This will recalibrate the incline system.

CONDITIONING GUIDELINES

⚠️ WARNING: Before beginning this or any exercise program, consult your physician. This is especially important for individuals over the age of 35 or individuals with pre-existing health problems.

The pulse sensor is not a medical device. Various factors, including your movement, may affect the accuracy of heart rate readings. The sensor is intended only as an exercise aid in determining heart rate trends in general.

The following guidelines will help you to plan your exercise program. Remember—these are general guidelines only. For more detailed exercise information, obtain a reputable book or consult your physician.

EXERCISE INTENSITY

Whether your goal is to burn fat or to strengthen your cardiovascular system, the key to achieving the desired results is to exercise with the proper intensity. The proper intensity level can be found by using your heart rate as a guide. The chart below shows recommended heart rates for fat burning and aerobic exercise.

	165	155	145	140	130	125	115
AEROBIC	165	155	145	140	130	125	115
MAX FAT BURN	145	138	130	125	118	110	103
FAT BURN	125	120	115	110	105	95	90
Age	20	30	40	50	60	70	80

To find the proper heart rate for you, first find your age near the bottom of the chart (ages are rounded off to the nearest ten years). Next, find the three numbers above your age. The three numbers define your “training zone.” The lower two numbers are recommended heart rates for fat burning; the higher number is the recommended heart rate for aerobic exercise.

To measure your heart rate during exercise, use the pulse sensor on the console. If your heart rate is too high or too low, adjust the speed and incline of the treadmill.

Fat Burning

To burn fat effectively, you must exercise at a relatively low intensity level for a sustained period of time. During the first few minutes of exercise, your body

uses easily accessible carbohydrate calories for energy. Only after the first few minutes does your body begin to use stored fat calories for energy. If your goal is to burn fat, adjust the speed and incline of the treadmill until your heart rate is near the lowest number in your training zone.

For maximum fat burning, adjust the speed and incline of the treadmill until your heart rate is near the middle number in your training zone.

Aerobic Exercise

If your goal is to strengthen your cardiovascular system, your exercise must be “aerobic.” Aerobic exercise is activity that requires large amounts of oxygen for prolonged periods of time. This increases the demand on the heart to pump blood to the muscles, and on the lungs to oxygenate the blood. For aerobic exercise, adjust the speed and incline of the treadmill until your heart rate is near the highest number in your training zone.

WORKOUT GUIDELINES

Each workout should include the following three parts:

A Warm-up—Start each workout with 5 to 10 minutes of stretching and light exercise. A proper warm-up increases your body temperature, heart rate and circulation in preparation for exercise.

Training Zone Exercise—After warming up, increase the intensity of your exercise until your pulse is in your training zone for 20 to 60 minutes. (During the first few weeks of your exercise program, do not keep your pulse in your training zone for longer than 20 minutes.) Breathe regularly and deeply as you exercise—never hold your breath.

A Cool-down—Finish each workout with 5 to 10 minutes of stretching to cool down. This will increase the flexibility of your muscles and will help prevent post-exercise problems.

Exercise Frequency

To maintain or improve your condition, complete three workouts each week, with at least one day of rest between workouts. After a few months, you may complete up to five workouts each week if desired.

The key to success is to make exercise a regular and enjoyable part of your everyday life.

SUGGESTED STRETCHES

The correct form for several basic stretches is shown at the right. Move slowly as you stretch—never bounce.

1. Toe Touch Stretch

Stand with your knees bent slightly and slowly bend forward from your hips. Allow your back and shoulders to relax as you reach down toward your toes as far as possible. Hold for 15 counts, then relax. Repeat 3 times. Stretches: Hamstrings, back of knees and back.

2. Hamstring Stretch

Sit with one leg extended. Bring the sole of the opposite foot toward you and rest it against the inner thigh of your extended leg. Reach toward your toes as far as possible. Hold for 15 counts, then relax. Repeat 3 times for each leg. Stretches: Hamstrings, lower back and groin.

3. Calf/Achilles Stretch

With one leg in front of the other, reach forward and place your hands against a wall. Keep your back leg straight and your back foot flat on the floor. Bend your front leg, lean forward and move your hips toward the wall. Hold for 15 counts, then relax. Repeat 3 times for each leg. To cause further stretching of the achilles tendons, bend your back leg as well. Stretches: Calves, achilles tendons and ankles.

4. Quadriceps Stretch

With one hand against a wall for balance, reach back and grasp one foot with your other hand. Bring your heel as close to your buttocks as possible. Hold for 15 counts, then relax. Repeat 3 times for each leg. Stretches: Quadriceps and hip muscles.

5. Inner Thigh Stretch

Sit with the soles of your feet together and your knees outward. Pull your feet toward your groin area as far as possible. Hold for 15 counts, then relax. Repeat 3 times. Stretches: Quadriceps and hip muscles.

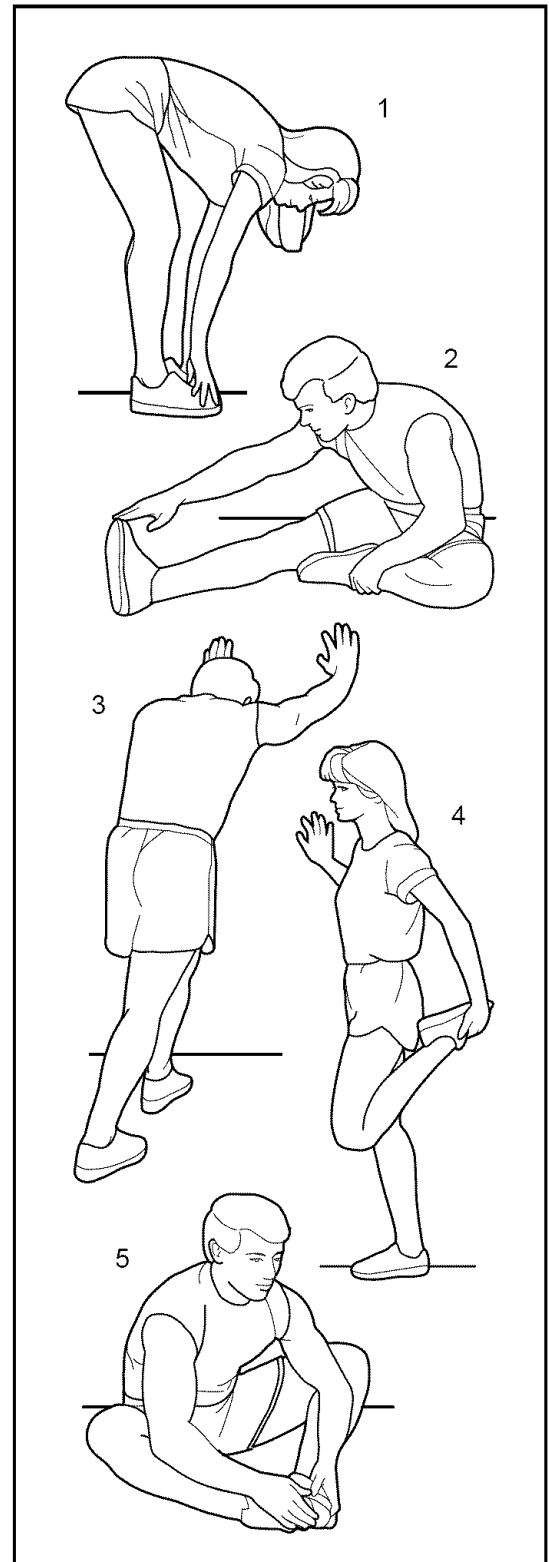

PART LIST—Model No. NTTL16901

R0102A

To locate the parts listed below, refer to the EXPLODED DRAWING attached in the center of this manual.

Key No.	Qty.	Description	Key No.	Qty.	Description
1	2	Foot Rail Insert	52	1	Walking Platform
2	2	Foot Rail	53	6	Platform Screw
3	2	Foot Rail Cap Screw	54	2	Rear Platform Screw
4	1	Left Foot Rail Cap	55	2	Rear Isolator
5	2	Frame Pivot Bolt	56	5	Ground Screw/Controller Screw
6	2	Frame Pivot Spacer	57	1	Ground Wire
7	1	Magnet	58	1	Rear Endcap
8	1	Front Roller/Pulley	59	2	Rear Roller Adj. Bolt
9	8	Frame Pivot Nut	60	1	Warning Decal
10	1	Reed Switch/Sensor Wire	61	1	Allen Wrench
11	4	U-nut	62	1	Rear Roller
12	1	Reed Switch Clip	63**	1	Optional Chest Pulse Strap
13	1	Lift Frame	64**	1	Optional Chest Pulse
14	3	Star Washer	65	2	Handrail Spacer
15*	1	Idler Assembly	66	1	Handrail
16	1	Motor/Pulley/Flywheel/Fan	67	2	Endcap Clip
17	1	Idler Arm	68	1	Lock Knob
18	1	Motor Belt	69	1	Upright
19	1	Idler Pulley	70	1	Lock Knob Sleeve
20	1	Tension Bolt	71	1	Spring
21	1	Incline Motor Bolt	72	1	Lock Pin Collar
22	2	Motor Bolt	73	1	Pin Clip
23	1	Hood	74	1	Lock Pin
24	1	Short Incline Motor Bolt	75	4	Handrail Bushing
25	4	Plastic Stand-Off	76	1	Pulse Grip
26	1	Power Board	77	4	Handrail Washer
27	9	Screw	78	4	Handrail Bolt
28	1	Pulley Spacer	79	2	Upright Endcap
29	1	Controller	80	1	Pulley Nut
30	1	Electronics Plate	81	1	Console Base
31	1	8" Wire Harness	82	1	Console
32	1	Front Roller Adj. Bolt	83	2	Belly Pan Screw (Short)
33*	1	Latch Assembly	84	1	Key/Clip
34	2	Roller Washer	85	1	iFIT.com Wire
35	1	Front Roller Nut	86	1	Jack
36	1	Incline Motor	87	4	Handrail Endcap
37	1	Incline Motor Stop	88	1	Console Back
38	1	Belly Pan	89	1	Releaseable Tie
39	2	Belly Pan Screw (Long)	90	10	1" Console Screw
40	2	Static Decal	91	3	Cable Tie Clamp
41	1	Circuit Breaker	92	7	8" Cable Tie
42	1	Power Cord	93	2	Lift Pivot Bolt
43	1	On/Off Switch	94	2	Wheel Bolt
44	1	Left Endcap Insert	95	2	Wheel
45	4	Belt Guide Screw	96	1	Right Endcap Insert
46	2	Belt Guide	97	1	Grommet
47	4	Isolator	98	1	Upright Wire Harness
48	1	Idler Spring	99	5	Base Pad
49	16	Fastener	100	13	Screw
50	1	Belly Pan	101	1	Tension Nut
51	1	Right Foot Rail Cap	102	2	Extension Leg

Key No.	Qty.	Description	Key No.	Qty.	Description
103	2	Extension Cap	121	1	Audio Wire Nut
104	2	Incline Warning Decal	#	2	Thick Base Pad
105	1	Shock	#	1	12" White Wire, M/F
106*	2	Extension Leg Assembly	#	1	10" White Wire, 2F
107	1	Grounding Bracket	#	1	14" Blue Wire, 2F
108	1	Book Holder	#	1	8" Blue Wire, M/F
109	1	Power Cord Grommet	#	1	4" Blue Wire, 2F
110	1	Frame	#	1	4" Black Wire, 2F
111	7	Catch Screw/Pulse Screw	#	1	12" Green Wire, 2 Ring
112	1	Catch	#	1	8" Green Wire, F/Ring
113	1	12" Audio Wire	#	1	7" Green Wire, M/Ring
114	1	Walking Belt	#	1	User's Manual
115	1	Tension Washer			
116	1	Idler Arm Bolt			
117	1	Lock Knob Spacer			
118	2	Hand Weight			
119	4	2" Console Screw			
120	1	Motor Isolator			

* Includes all parts shown in the box
**For information about the optional chest pulse sensor, see page 24
These parts are not illustrated

ORDERING REPLACEMENT PARTS

To order replacement parts, call our Customer Service Department toll-free at 1-888-825-2588, Monday through Friday, 6 a.m. until 6 p.m. Mountain Time (excluding holidays). When ordering parts, please be prepared to give the following information:

- The MODEL NUMBER OF THE PRODUCT (NTTL16901)
- The NAME OF THE PRODUCT (NordicTrack® SUMMIT 4500 treadmill)
- The SERIAL NUMBER OF THE PRODUCT (see the front cover of this manual)
- The KEY NUMBER AND DESCRIPTION OF THE PART(S) (see the PART LIST on pages 30 and 31 and the EXPLODED DRAWING attached in the center of this manual).

If possible, place the treadmill near your telephone for easy reference when calling.

EXPLODED DRAWING—Model No. NTTL16901

R0102A

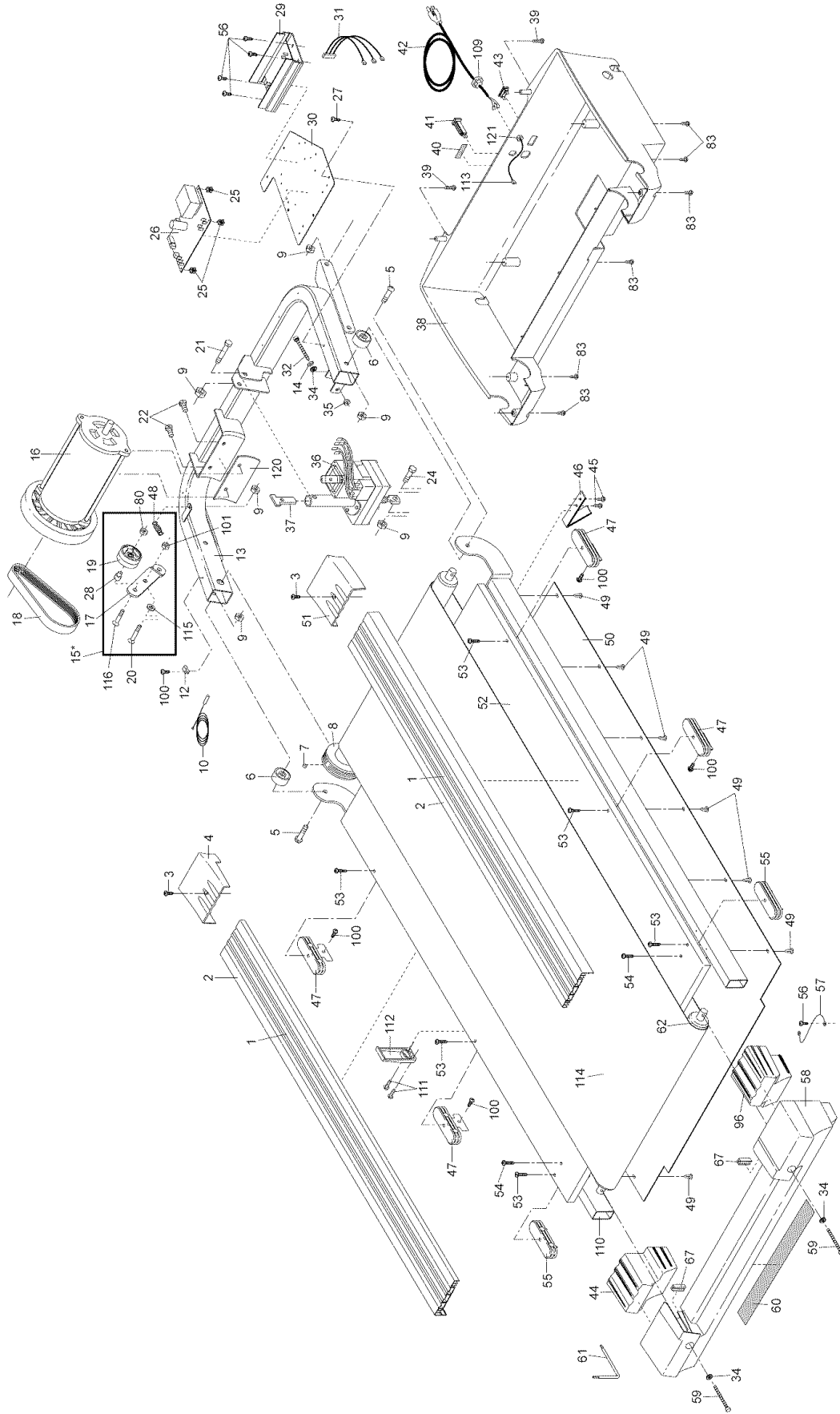

To identify the parts shown on this exploded drawing, refer to the PART LIST on pages 30 and 31 of the USER'S MANUAL.

EXPLODED DRAWING—Model No. NTTL16901

R0102A

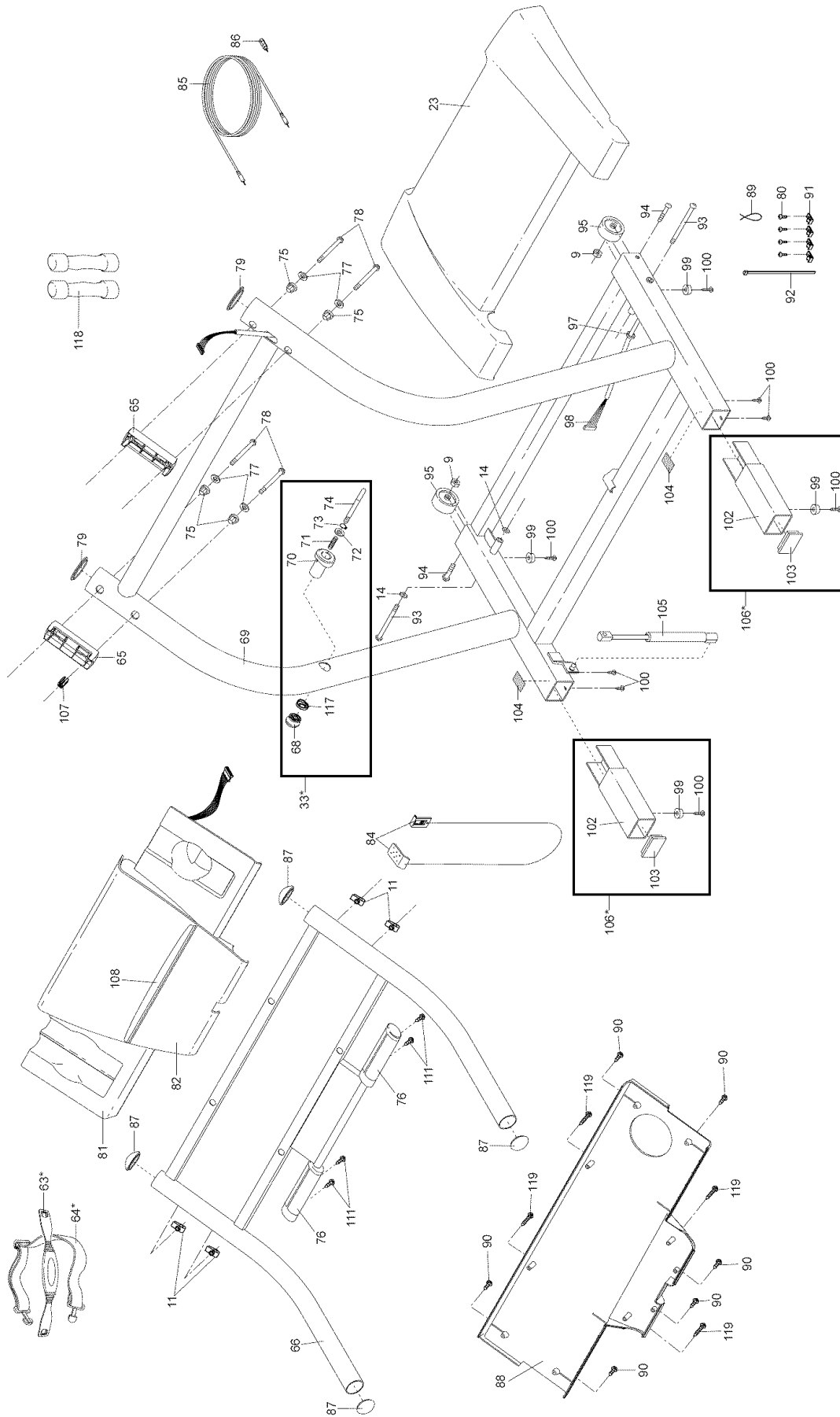

LIMITED WARRANTY

WHAT IS COVERED—The entire NordicTrack® SUMMIT 4500 treadmill ("Product") is warranted to be free of all defects in material and workmanship.

WHO IS COVERED—The original purchaser or any person receiving the Product as a gift from the original purchaser.

HOW LONG IS IT COVERED—ICON Health & Fitness, Inc. ("ICON"), warrants the motor for three years after the date of purchase. The belt and deck are covered for two years after the date of purchase. All mechanical components are covered for two years after the date of purchase. All electrical components are covered for two years after the date of purchase. Labor is covered for one year. The hood, covers, belly pan, and decals are covered for six months after the date of purchase.

WHAT WE DO TO CORRECT COVERED DEFECTS—We will ship to you, without charge, any replacement part or component, providing the repairs are authorized by ICON first and are performed by an ICON trained and authorized service provider, or, at our option, we will replace the Product.

WHAT IS NOT COVERED—Any failures or damage caused by unauthorized service, misuse, accident, negligence, improper assembly or installation, alterations, modifications without our written authorization or by failure on your part to use, operate, and maintain as set out in your User's Manual ("Manual"). This warranty does not extend to products used for commercial or rental purposes or to products used as store display modules.

WHAT YOU MUST DO—Always retain proof of purchase, such as your bill of sale; store, operate, and maintain the Product as specified in the Manual; notify our Customer Service Department of any defect within 10 days after discovery of the defect; as instructed, return any defected part for replacement or, if necessary, the entire product, for repair.

USER'S MANUAL—It is VERY IMPORTANT THAT YOU READ THE MANUAL before operating the Product. Remember to do the periodic maintenance requirements specified in the Manual to assure proper operation and your continued satisfaction.

HOW TO GET PARTS AND SERVICE—Simply call our Customer Service Department at 1-888-825-2588 and tell them your name and address and the serial number of your Product. They will tell you how to get a part replaced, or if necessary, arrange for service where your Product is located or advise you how to ship the Product for service. Before shipping, always obtain a Return Authorization Number (RA No.) from our Customer Service Department; securely pack your Product (save the original shipping carton if possible); put the RA No. on the outside of the carton and insure the product. Include a letter explaining the product or problem and a copy of your proof of purchase if you believe the service is covered by warranty.

ICON is not responsible or liable for indirect, special or consequential damages arising out of or in connection with the use or performance of the product or damages with respect to any economic loss, loss of property, loss of revenues or profits, loss of enjoyment or use, costs of removal, installation or other consequential damages of whatsoever nature. Some states do not allow the exclusion or limitation of incidental or consequential damages. Accordingly, the above limitation may not apply to you.

The warranty extended hereunder is in lieu of any and all other warranties and any implied warranties of merchantability or fitness for a particular purpose is limited in its scope and duration to the terms set forth herein. Some states do not allow limitations on how long an implied warranty lasts. Accordingly, the above limitation may not apply to you.

No one is authorized to change, modify or extend the terms of this limited warranty.

This warranty gives you specific legal rights and you may have other rights which vary from state to state.

ICON HEALTH & FITNESS, INC., 1500 S. 1000 W., LOGAN, UT 84321-9813