

# Electric Built-In Cooktop

*Safety Information* ..... 2-5

*Operating Instructions*

Cookware Tips .....7

Surface Units .....6

*Care and Cleaning*

Control Knobs ..... 8

Porcelain Enamel Cooktop .... 8

Stainless Steel Cooktop .....8

Surface Units and Drip Pans ....9

*Installation Instructions*

Electrical Connections .....10

Electrical Requirements ..... 10

Installation of the Cooktop ....13

Optional Location .....12

Tools You Will Need ..... 10

Typical Location .....11

*Troubleshooting Tips* ..... 14

*Consumer Support*

Consumer Support ... Back Cover

Warranty ..... 15

**GE Quality Product**

**Owner's Manual &  
Installation Instructions**

JP200

JP201

JP202

**Write the model and serial numbers here:**

**Model #** \_\_\_\_\_

**Serial #** \_\_\_\_\_

You can find them on a label on the bottom of the cooktop.

## **IMPORTANT SAFETY INFORMATION. READ ALL INSTRUCTIONS BEFORE USING.**

### **⚠ WARNING!**

*For your safety, the information in this manual must be followed to minimize the risk of fire or explosion, electric shock, or to prevent property damage, personal injury, or loss of life.*



### **SAFETY PRECAUTIONS**

*When using electrical appliances, basic safety precautions should be followed, including the following:*

- Use this appliance only for its intended use as described in this manual.
  - Do not attempt to repair or replace any part of your cooktop unless it is specifically recommended in this manual. All other servicing should be referred to a qualified technician.
  - Be sure your appliance is properly installed and grounded by a qualified technician in accordance with the provided Installation Instructions.
  - Before performing any service, **DISCONNECT THE COOKTOP POWER SUPPLY AT THE HOUSEHOLD DISTRIBUTION PANEL BY REMOVING THE FUSE OR SWITCHING OFF THE CIRCUIT BREAKER.**
  - Do not leave children alone—children should not be left alone or unattended in an area where an appliance is in use. They should never be allowed to sit or stand on any part of the appliance.
  - Do not allow anyone to climb, stand or hang on the cooktop.
- **CAUTION:** Items of interest to children should not be stored in cabinets above a cooktop—children climbing on the cooktop to reach items could be seriously injured.
  - Never wear loose-fitting or hanging garments while using the appliance. Be careful when reaching for items stored in cabinets over the cooktop. Flammable material could be ignited if brought in contact with hot surface units and may cause severe burns.
  - Always keep dish towels, dish cloths, pot holders and other linens a safe distance from your cooktop.
  - Always keep wooden and plastic utensils and canned food a safe distance away from your cooktop.

## **⚠ WARNING!**

*For your safety, the information in this manual must be followed to minimize the risk of fire or explosion, electric shock, or to prevent property damage, personal injury, or loss of life.*



## **SAFETY PRECAUTIONS**

*When using electrical appliances, basic safety precautions should be followed, including the following:*

- Teach children not to play with the controls or any other part of the cooktop.
  - Always keep combustible wall coverings, curtains or drapes a safe distance from your cooktop.
  - Use only dry pot holders—moist or damp pot holders on hot surfaces may result in burns from steam. Do not let pot holders touch hot surface units. Do not use a towel or other bulky cloth in place of a pot holder. Such cloths can catch fire on a hot surface unit.
  - Do not use water on grease fires. Never pick up a flaming pan. Turn off the surface unit then smother flaming pan by covering pan completely with well-fitting lid, cookie sheet or flat tray or, if available, a multi-purpose dry chemical or foam-type extinguisher.
- Flaming grease inside or outside a pan can be put out by covering with baking soda or, if available, a multi-purpose dry chemical or foam-type fire extinguisher.

## IMPORTANT SAFETY INFORMATION. READ ALL INSTRUCTIONS BEFORE USING.

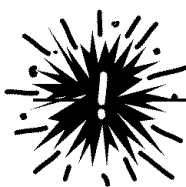

### **⚠ WARNING!** SAFETY PRECAUTIONS

- Do not store flammable materials near the cooktop.
- Keep hood and grease filters clean to maintain good venting and to avoid grease fires.
- Do not flame foods on the cooktop. If you do flame foods under the hood, turn the fan on.
- Do not let cooking grease or other flammable materials accumulate on the cooktop.
- Do not touch surface units. These surfaces may be hot enough to burn even though they are dark in color. During and after use, do not touch, or let clothing or other flammable materials contact surface units or areas nearby surface units; allow sufficient time for cooling first. Potentially hot surfaces include the cooktop and areas facing the cooktop.
- To minimize the possibility of burns, ignition of flammable materials and spillage, the handle of a container should be turned toward the center of the cooktop without extending over any nearby surface units.
- Always turn the surface units to **OFF** before removing cookware.
- To avoid the possibility of a burn or electric shock, always be certain that the controls for all surface units are at the **OFF** position and all surface units are cool before attempting to lift or remove the unit.
- Do not immerse or soak the removable surface units. Do not put them in a dishwasher.
- Clean the cooktop with caution. If a wet sponge or cloth is used to wipe spills on a hot surface, be careful to avoid steam burns.
- Do not store or use combustible materials, gasoline or other flammable vapors and liquids in the vicinity of this or any appliance.
- Clean only parts listed in this Owner's Manual.
- Do not leave paper products, cooking utensils or food on the cooktop when not in use.
- Keep cooktop clean and free of accumulation of grease or spillovers which may ignite.
- Never heat unopened food containers. Pressure buildup may make container burst and cause injury.
- Never leave jars or cans of fat drippings on or near your cooktop.
- Never use your appliance for warming or heating the room.



### COOK MEAT AND POULTRY THOROUGHLY...

*Cook meat and poultry thoroughly—meat to at least an INTERNAL temperature of 160°F and poultry to at least an INTERNAL temperature of 180°F. Cooking to these temperatures usually protects against foodborne illness.*

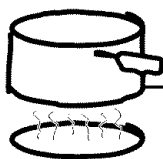

## SURFACE COOKING UNITS

*Use proper pan size—This appliance is equipped with different size surface units. Select cookware having flat bottoms large enough to cover the surface unit heating element. The use of undersized cookware will expose a portion of the surface unit to direct contact and may result in ignition of clothing. Proper relationship of the cookware to the surface unit will also improve efficiency.*

- Never leave the surface units unattended at high heat settings. Boilovers cause smoking and greasy spillovers that may catch on fire.
- Be sure the drip pans and the duct are not covered and are in place. Their absence during cooking could damage cooktop parts and wiring.
- Do not use aluminum foil to line the drip pans. Misuse could result in a shock, fire hazard or damage to the cooktop.
- Only certain types of glass, glass/ceramic, earthenware or other glazed containers are suitable for cooktop service; others may break because of the sudden change in temperature.
- Keep an eye on foods being fried at **HI** or **Medium High** heat settings.
- Foods for frying should be as dry as possible. Frost on frozen foods or moisture on fresh foods can cause hot fat to bubble up and over the sides of the pan.
- Use little fat for effective shallow or deep-fat frying. Filling the pan too full of fat can cause spillovers when food is added.
- If a combination of oils or fats will be used in frying, stir together before heating, or as fats melt slowly.
- Always heat fat slowly, and watch as it heats.
- Use a deep fat thermometer whenever possible to prevent overheating fat beyond the smoking point.
- Never try to move a pan of hot fat, especially a deep fat fryer. Wait until the fat is cool.



**READ AND FOLLOW THIS SAFETY INFORMATION CAREFULLY.  
SAVE THESE INSTRUCTIONS**

Safety Instructions

Operating Instructions

Care and Cleaning

Installation Instructions

Troubleshooting Tips

Consumer Support

## Using the cooktop.

Throughout this manual, features and appearance may vary from your model.

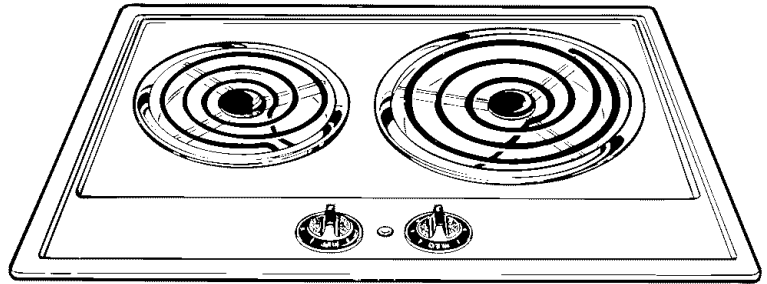

### Cooktop Controls

Your surface units and controls are designed to give you an infinite choice of heat settings for surface unit cooking.

At both **OFF** and **HI** the control **clicks** into position.

When cooking in a quiet kitchen, you may hear slight **clicking** sounds—an indication that the heat settings you selected are being maintained.

Switching heats to higher settings always results in a quicker change than switching to lower settings.

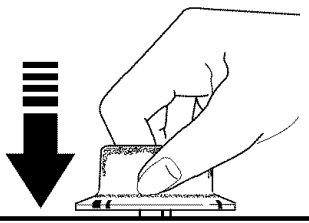

### How to Set the Controls

- 1 Grasp the control knob and push down.
- 2 Turn the knob to the desired heat setting.

The control must be pushed in to set only from the **OFF** position. When the control is in any position other than **OFF**, it may be rotated without pushing in.

Be sure you turn the control knob to **OFF** when you finish cooking.

An indicator light will glow when a surface unit is on.

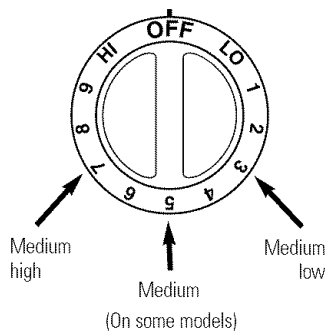
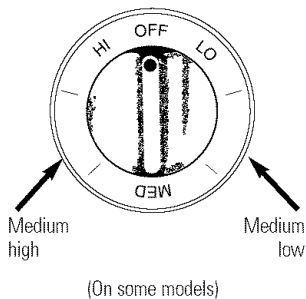

### Heat Setting Guide

|                         |   |
|-------------------------|---|
| <b>HI</b>               | Quick start for cooking; bring water to boil.   |
| <b>Medium High, 7-9</b> | (Setting halfway between HI and MED)<br>Maintains a fast boil on large amounts of food.   |
| <b>MED, 4-6</b>         | Sauté and brown; keeps food at medium boil or simmer.   |
| <b>Medium Low, 1-3</b>  | (Setting halfway between MED and LO)<br>Cook after starting at <b>HI</b> ; cooks with little water in a covered pan.  |
| <b>LO</b>               | Steam rice, cereal; maintains serving temperature of foods. Slow cooking and simmering. At <b>LO</b> settings, melt chocolate and butter on a small surface unit. |

**NOTE:** At **HI** or **Medium High (7-9)** never leave food unattended. Boilovers cause smoking; greasy spillovers may catch fire.

## Right

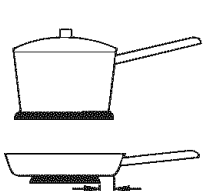

Not over 1 inch

## Wrong

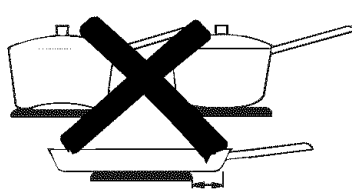

Over 1 inch

Use medium- or heavy-weight cookware. Aluminum cookware conducts heat faster than other metals. Cast-iron and coated cast-iron cookware are slow to absorb heat, but generally cook evenly at low to medium heat settings. Steel pans may cook unevenly if not combined with other metals.

For best cooking results pans should be flat on the bottom. Match the size of the saucepan to the size of the surface unit. The pan should not extend over the edge of the trim ring more than 1 inch.

## Deep Fat Frying

Do not overfill cookware with fat that may spill over when adding food. Frosty foods bubble vigorously. Watch food frying at high temperatures. Keep range and hood clean from grease.

## Wok Cooking

We recommend that you use only a flat-bottomed wok. They are available at your local retail store.

Do not use woks that have support rings. Use of these types of woks, with or without the ring in place, can be dangerous. Placing the ring over the surface unit will cause a build-up of heat that will damage the cooktop.

Do not try to use such woks without the ring. You could be seriously burned if the wok tipped over.

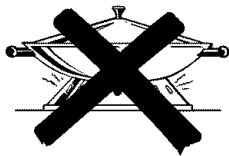

Use only flat-bottomed woks.

## Home Canning Tips

Be sure the canner is centered over the surface unit.

Make sure the canner is flat on the bottom.

Use recipes and procedures from reputable sources. These are available from manufacturers such as Ball® and Kerr® and the Department of Agriculture Extension Service.

To prevent burns from steam or heat, use caution when canning.

## Care and cleaning of the cooktop.

Be sure electrical power is off and all surfaces are cool before cleaning any part of the cooktop.

Proper care and cleaning are important so your cooktop will give you efficient and satisfactory service. Follow these directions carefully in caring for your cooktop to assure safe and proper maintenance.

### Control Knobs

The control knobs may be removed for easier cleaning.

Make sure the knobs are in the **OFF** positions and pull them straight off the stems for cleaning.

The knobs can be cleaned in a dishwasher or they may also be washed with soap and water. Make sure the inside of the knobs are dry before replacing.

Replace the knobs in the **OFF** position to ensure proper placement.

### Porcelain Enamel Cooktop (on some models)

The porcelain enamel finish is sturdy but breakable if misused.

This finish is acid-resistant. However, any acid foods spilled (such as fruit juices, tomato or vinegar) should not be permitted to remain on the finish.

If acids spill on the cooktop while it is hot, use a dry paper towel or cloth to wipe it up right away. When the surface has cooled, wash with soap and water. Rinse well.

For other spills such as fat splatterings, wash with soap and water or cleansing powders after the surface has cooled. Rinse well. Polish with a dry cloth.

### Stainless Steel Cooktop (on some models)

**Do not use a steel wool pad; it will scratch the surface.**

To clean the stainless steel surface, use warm sudsy water or a stainless steel cleaner or polish. Always wipe the surface in the direction of the grain. Follow the cleaner instructions for cleaning the stainless steel surface.

To inquire about purchasing stainless steel appliance cleaner or polish, or to find the location of a dealer nearest you, please call our toll-free number:

**National Parts Center**      **1.800.626.2002**  
**ge.com**



To clean the surface units, turn the control to the highest setting for a minute. The coils will burn off any soil.

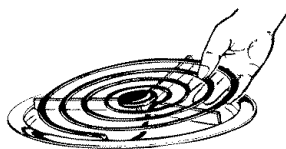

Lift the surface unit about 1 inch above the drip pan and pull it out.

## Surface Units and Drip Pans

### CAUTION

- Be sure all the controls are turned to **OFF** and the surface units are cool before attempting to remove them.
- Do not immerse the surface units in liquids of any kind.
- Do not clean the surface units in a dishwasher.
- Do not bend the surface unit plug terminals.
- Do not attempt to clean, adjust or in any way repair the plug-in receptacle.

### To remove a surface unit:

To remove the drip pans for cleaning, the surface units must be removed first.

Lift the surface unit about 1 inch above the drip pan and pull it out.

Do not lift the surface unit more than 1 inch. If you do, it may not lie flat on the drip pan when you plug it back in.

Repeated lifting of the surface unit more than 1 inch above the drip pan can permanently damage the receptacle.

### To replace a surface unit:

- Replace the drip pan into the recess in the cooktop. Make sure opening in the pan lines up with the receptacle.
- Insert the terminals of the surface unit through the opening in the drip pan and into the receptacle.
- Guide the surface unit into place so it rests evenly.

### Drip Pans

Remove the surface units. Then lift out the drip pans.

For best results, clean the drip pans by hand. Place them in a covered container (or a plastic bag) with 1/4 cup ammonia to loosen the soil. Then scrub with a soap filled scouring pad if necessary. Rinse with clean water and polish with a clean soft cloth.

*The drip pans may also be cleaned in the dishwasher.*

Clean the area under the drip pans often. Built-up soil, especially grease, may catch on fire.

Do not cover drip pans with foil. Using foil so close to the receptacle could cause shock, fire or damage to the cooktop.

## Installation of the cooktop.

Read these instructions completely and carefully.



### Before You Begin

Read these instructions completely and carefully.

**IMPORTANT**—Save these instructions for local inspector's use.

**IMPORTANT**—Observe all governing codes and ordinances.

**NOTE TO INSTALLER**—Be sure to leave these instructions with the Consumer.

**NOTE:** This appliance must be properly grounded.



### Tools You Will Need

- 1/8" Drill bit
- Electric or hand drill
- Flat blade screwdriver
- Pencil
- Ruler or tape measure and straightedge
- Hand saw or saber saw

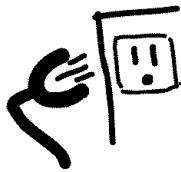

### Electrical Requirements

**CAUTION:** for personal safety, remove house fuse or circuit breaker before beginning installation.

This appliance must be supplied with the proper voltage and frequency and connected to an individual, properly grounded branch circuit, protected by a circuit breaker or time delay fuse, as noted on the rating plate.

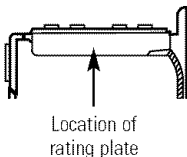

Location of rating plate

All wire connections must be made in accordance with local codes and properly insulated. Check with your local utility for governing electrical codes and ordinances.

In the absence of local electrical codes, the National Electrical Code, ANSI/NFPA No. 70—Latest Edition, governing electric range installations, must be followed.

A copy of the National Electrical Code can be obtained by writing to:

National Fire Protection Association  
Batterymarch Park  
Quincy, MA 02260

*If you fail to wire your counter unit in accordance with governing codes, you may create a hazardous condition.*



### Electrical Connections

**⚠ DANGER:** The electrical power to the counter unit supply line must be shut off while line connections are being made. Failure to do so could result in serious injury or death.

You must use a two-wire A.C. 208/240 Volt, 60 Hertz electrical system. A white (neutral) wire is not needed for this unit. The white lead from the household electrical supply can be isolated and secured in the junction box. **If you connect to aluminum wiring, properly installed connections listed for use with aluminum and copper wiring must be used.**

Use a minimum wire size of No. 12 copper wire with a 20 Amp fuse or circuit breaker for both 208/240 Volt electrical systems.

When making the wire connections, use the entire length of conduit provided. The conduit must not be cut.

Connect the red and black leads from the counter unit conduit to the corresponding leads in the junction box.

The bare ground wire in the conduit is connected to the counter unit frame. It must be connected to the household electrical supply ground.

# Typical installation location.

(if installing the cooktop over a GSM2100 dishwasher, go to the next page)

ge.com

Read these instructions completely and carefully.

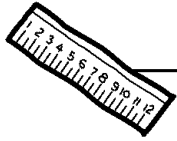

## Dimensions and Clearances

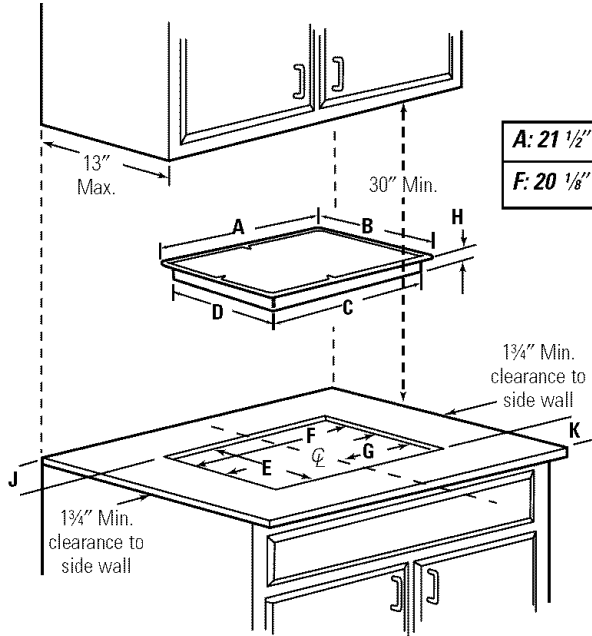

|                   |                    |                     |                     |                       |
|-------------------|--------------------|---------------------|---------------------|-----------------------|
| <b>A:</b> 21 1/2" | <b>B:</b> 16 5/8"  | <b>C:</b> 19 15/16" | <b>D:</b> 15 15/16" | <b>E:</b> 16 1/8"     |
| <b>F:</b> 20 1/8" | <b>G:</b> 10 1/16" | <b>H:</b> 3"        | <b>J:</b> 2" Min.   | <b>K:</b> 2 3/4" Min. |

Unit and cutout dimensions

This counter unit must be installed with the control knobs toward the front edge or the side.

Counter space must be provided for installation of the counter unit. When choosing a location, consider the following:

- The cooktop should be easy to reach and lighted with natural light during the day.
- To eliminate the risk of burns or fire by reaching over heated surface units, cabinet storage space located above the surface units should be avoided. If cabinet storage space is to be provided, the risk can be reduced by installing a range hood that projects horizontally a minimum of 5" beyond the bottom of the cabinets. Cabinets installed above the counter unit may be no deeper than 13" and must be at least 30" above the cooktop.
- To insure accuracy, it is best to make a template when cutting the opening in the counter. See the following illustration and chart for all necessary dimensions.

The following minimum clearances must be maintained:

- 2 3/4" minimum clearance between the front edge of the counter unit and the front edge of the counter.
- 30" minimum vertical clearance from the cooktop to the nearest overhead surface.
- 18" minimum vertical clearance to adjacent cabinets.
- 1 1/2" minimum vertical clearance between the bottom of the cooktop and any combustible material, i.e. shelving.

Safety Instructions

Operating Instructions

Care and Cleaning

Installation Instructions

Troubleshooting Tips

Consumer Support

## Optional installation over GE undersink dishwasher model GSM2100. (if not installing the cooktop over a dishwasher, go to the next page)

Read these instructions completely and carefully.

### Dimensions and Clearances for Optional Installation

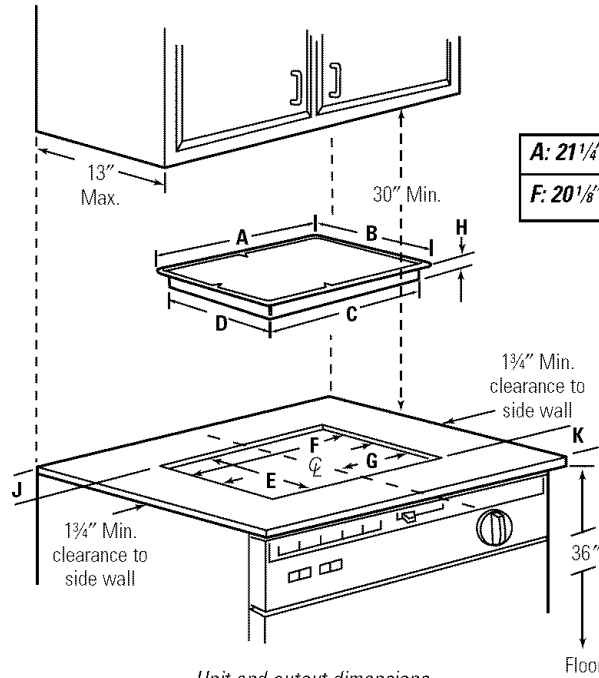

|                                     |                                      |                                       |                                       |   |
|-------------------------------------|--------------------------------------|---------------------------------------|---------------------------------------|---|
| A: 21 <sup>1</sup> / <sub>4</sub> " | B: 16 <sup>5</sup> / <sub>8</sub> "  | C: 19 <sup>15</sup> / <sub>16</sub> " | D: 15 <sup>15</sup> / <sub>16</sub> " | E: 16 <sup>1</sup> / <sub>8</sub> "     |
| F: 20 <sup>1</sup> / <sub>8</sub> " | G: 10 <sup>1</sup> / <sub>16</sub> " | H: 3"                                 | J: 2" Min.                            | K: 3 <sup>3</sup> / <sub>4</sub> " Min. |

Unit and cutout dimensions

*This counter unit must be installed with the control knobs toward the front edge of the countertop.*

**Counter space must be provided for installation of the counter unit. When choosing the location of the cooktop and dishwasher, consider the following:**

- When installing over a dishwasher, cooktop models JP200, JP201 and JP202 are only approved for installation over GE Undersink Dishwasher model GSM2100. Install the dishwasher using the separate installation instructions packed with the dishwasher.
- The cooktop should be easy to reach and lighted with natural light during the day.
- To eliminate the risk of burns or fire by reaching over heated surface units, cabinet storage space located above the surface units should be avoided. If cabinet storage space is to be provided, the risk can be reduced by installing a range hood that projects horizontally a minimum of 5" beyond the bottom of the cabinets. Cabinets installed above the counter unit may be no deeper than 13" and must be at least 30" above the cooktop.

- The cooktop must be centered left to right over the dishwasher unit.
- To insure accuracy, it is best to make a template when cutting the opening in the counter. See the illustration and chart above for all necessary dimensions.

**The following minimum clearances must be maintained:**

- 3/4" minimum clearance between the front edge of the counter unit and the front edge of the counter.
- 30" minimum vertical clearance from the cooktop to the nearest overhead surface.
- 18" minimum vertical clearance to adjacent cabinets.

# Installation of the cooktop.

ge.com

Read these instructions completely and carefully.

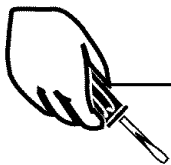

## Installation Instruction

Be sure this cut does not interfere with the cabinet structure at the front

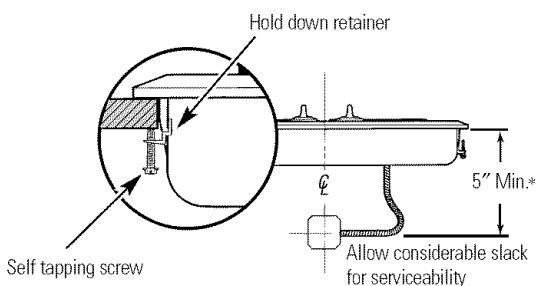
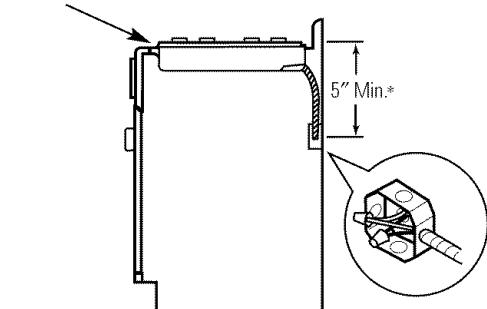

\* Max. distance of 7" when installing over GSM2100 dishwasher  
Suggested mounting of an approved junction box.

**Before installing the counter unit or moving it to another location have the electrician verify:**

- That your home is provided with adequate electrical service.
- That the addition of the counter unit will not overload the household circuit on which it is used.

**⚠ DANGER:** Always disconnect the electrical service to the unit before repairing or servicing the counter unit. This can be done by disconnecting the fuse or circuit breaker. Failure to do this could result in a dangerous or even fatal shock. Know where your main disconnect switch is located. If you don't know, have your electrician show you.

Install an approved junction box where it will be easily accessible through the front of the cabinet where the counter unit will be located.

**IMPORTANT:** The junction box must be located where it will allow slack in the conduit for serviceability. If installing over a GSM2100 dishwasher, the center of the junction box must be installed 5' to 7" below the cooktop lip, so it does not interfere with the dishwasher installation or operation.

Install the counter unit in the cutout opening.

**NOTE:** If the unit is being installed in a blind counter (one with no cabinet opening below) or over a GSM2100 dishwasher, wire connections must be made before putting the unit into the cutout.

Secure the cooktop unit to the counter using the side retainers and screws shipped with the unit.

- For thicker counters (greater than 1" thick), hold down straps should be used to install the cooktop. They are included with some models, or can be ordered, GE model number WB2K5328.
- To attach the cooktop to the counter, insert the hold-down strap into the slots on each side of the unit (see diagram).
- Use suitable screws to attach the cooktop to the counter as shown. The cooktop must rest on the metal flange around the burner box.

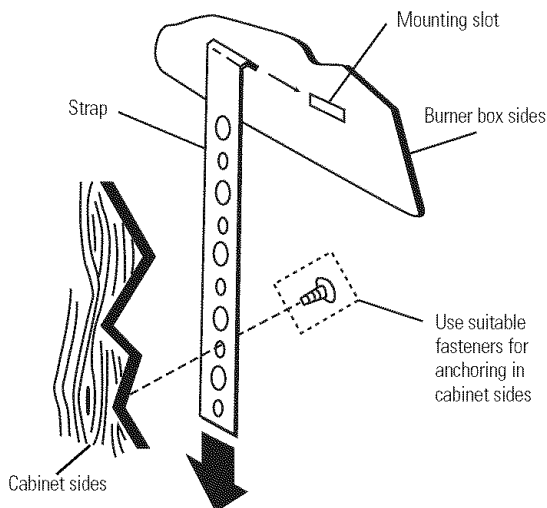

Safety Instructions

Operating Instructions

Care and Cleaning

Installation Instructions

Troubleshooting Tips

Consumer Support

## Before You Call For Service...



**Troubleshooting Tips**  
 Save time and money! Review the chart on this page first and you may not need to call for service.

| <b>Problem</b>                                | <b>Possible Causes</b>   | <b>What To Do</b>  |
|---|--|--|
| <b>Surface units not functioning properly</b> | The surface units are not plugged in solidly.                    | <ul style="list-style-type: none"> <li>• With the controls off, check to make sure the surface unit is plugged completely into the receptacle.</li> </ul>  |
|   | The surface unit controls are improperly set.                    | <ul style="list-style-type: none"> <li>• Check to see the correct control is set for the surface unit you are using.</li> </ul>  |
|   | The drip pans are not set securely in the cooktop.               | <ul style="list-style-type: none"> <li>• With the controls off, check to make sure the drip pan is in the recess in the cooktop and that the opening in the pan lines up with the receptacle.</li> </ul> |
|   | A fuse in your home may be blown or the circuit breaker tripped. | <ul style="list-style-type: none"> <li>• Replace the fuse or reset the circuit breaker.</li> </ul>   |

## Built-In Cooktop Warranty.



All warranty service provided by our Factory Service Centers, or an authorized Customer Care® technician. To schedule service, on-line, 24 hours a day, visit us at [ge.com](http://ge.com), or call 800.GE.CARES (800.432.2737). Please have serial number and model number available when calling for service.

Staple your receipt here.  
Proof of the original purchase date is needed to obtain service under the warranty.

### For The Period Of: We Will Replace:

#### One Year

From the date of the original purchase

**Any part** of the cooktop which fails due to a defect in materials or workmanship. During this **limited one-year warranty**, GE will also provide, **free of charge**, all labor and related service to replace the defective part.

### What is Not Covered:

- Service trips to your home to teach you how to use the product.
- Improper installation, delivery or maintenance.
- Failure of the product if it is abused, misused, or used for other than the intended purpose or used commercially.
- Damage caused after delivery.
- Replacement of house fuses or resetting of circuit breakers.
- Damage to the product caused by accident, fire, floods or acts of God.
- Incidental or consequential damage caused by possible defects with this appliance.
- Product not accessible to provide required service.

**EXCLUSION OF IMPLIED WARRANTIES—Your sole and exclusive remedy is product repair as provided in this Limited Warranty. Any implied warranties, including the implied warranties of merchantability or fitness for a particular purpose, are limited to one year or the shortest period allowed by law.**

This warranty is extended to the original purchaser and any succeeding owner for products purchased for home use within the USA. In Alaska, the warranty excludes the cost of shipping or service calls to your home.

Some states do not allow the exclusion or limitation of incidental or consequential damages. This warranty gives you specific legal rights, and you may also have other rights which vary from state to state. To know what your legal rights are, consult your local or state consumer affairs office or your state's Attorney General.

Warrantor: General Electric Company, Louisville, KY 40225

Safety Instructions

Operating Instructions

Care and Cleaning

Installation Instructions

Troubleshooting Tips

Consumer Support

## Consumer Support.

---



### *GE Appliances Website*

**ge.com**

Have a question or need assistance with your appliance? Try the GE Appliances Website 24 hours a day, any day of the year! For greater convenience and faster service, you can now download Owner's Manuals, order parts, catalogs, or even schedule service on-line. You can also "Ask Our Team of Experts™" your questions, and so much more...

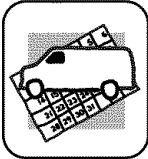

### *Schedule Service*

**ge.com**

Expert GE repair service is only one step away from your door. Get on-line and schedule your service at your convenience 24 hours any day of the year! Or call 800.GE.CARES (800.432.2737) during normal business hours.

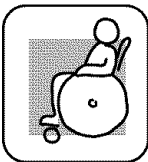

### *Real Life Design Studio*

**ge.com**

GE supports the Universal Design concept—products, services and environments that can be used by people of all ages, sizes and capabilities. We recognize the need to design for a wide range of physical and mental abilities and impairments. For details of GE's Universal Design applications, including kitchen design ideas for people with disabilities, check out our Website today. For the hearing impaired, please call 800.TDD.GEAC (800.833.4322).



### *Extended Warranties*

**ge.com**

Purchase a GE extended warranty and learn about special discounts that are available while your warranty is still in effect. You can purchase it on-line anytime, or call 800.626.2224 during normal business hours. GE Consumer Home Services will still be there after your warranty expires.

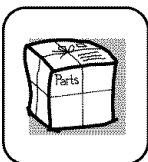

### *Parts and Accessories*

**ge.com**

Individuals qualified to service their own appliances can have parts or accessories sent directly to their homes (VISA, MasterCard and Discover cards are accepted). Order on-line today, 24 hours every day or by phone at 800.626.2002 during normal business hours.

***Instructions contained in this manual cover procedures to be performed by any user. Other servicing generally should be referred to qualified service personnel. Caution must be exercised, since improper servicing may cause unsafe operation.***



### *Contact Us*

**ge.com**

If you are not satisfied with the service you receive from GE, contact us on our Website with all the details including your phone number, or write to: General Manager, Customer Relations  
GE Appliances, Appliance Park  
Louisville, KY 40225



### *Register Your Appliance*

**ge.com**

**Register your new appliance on-line—at your convenience!** Timely product registration will allow for enhanced communication and prompt service under the terms of your warranty, should the need arise. You may also mail in the preprinted registration card included in the packing material.