

SEARS

CRAFTSMAN®

MODEL NUMBER 917.386132 OWNER'S MANUAL

EZ³



- Assembly
- Operation
- Customer Responsibilities
- Service
- Adjustments
- Repair Parts

Caution:
Read and Follow
all Safety Rules
and Instructions
Before Operating
This Equipment

156050 6.21.96 VBL

Printed in U.S.A.

Sears, Roebuck and Co., Hoffman Estates, IL 60179 U.S.A.



SAFETY RULES



Safe Operation Practices for Walk-Behind Mowers

IMPORTANT: THIS CUTTING MACHINE IS CAPABLE OF AMPUTATING HANDS AND FEET AND THROWING OBJECTS. FAILURE TO OBSERVE THE FOLLOWING SAFETY INSTRUCTIONS COULD RESULT IN SERIOUS INJURY OR DEATH. SAFETY STANDARDS REQUIRE OPERATOR PRESENCE CONTROLS TO MINIMIZE THE RISK OF INJURY. YOUR UNIT IS EQUIPPED WITH SUCH CONTROLS. DO NOT ATTEMPT TO DEFEAT THE FUNCTION OF THE OPERATOR PRESENCE CONTROLS UNDER ANY CIRCUMSTANCES.

TRAINING:

- Read this operator's manual carefully. Become familiar with the controls and know how to operate your mower properly. Learn how to quickly stop mower.
- Do not allow children to use your mower. Never allow adults to use mower without proper instructions.
- Keep the area of operation clear of all persons, especially small children and pets.
- Use mower only as the manufacturer intended and as described in this manual.
- Do not operate mower if it has been dropped or damaged in any manner. Always have damage repaired before using your mower.
- Do not use accessory attachments that are not recommended by the manufacturer. Use of such attachments may be hazardous.
- The blade turns when the engine is running.

PREPARATION:

- Always thoroughly check the area to be mowed and clear it of all stones, sticks, wires, bones, and other foreign objects. These objects will be thrown by the blade and can cause severe injury.
- Always wear safety glasses or eye shields when starting and while using your mower.
- Dress properly. Do not operate mower when barefoot or wearing open sandals. Wear only solid shoes with good traction when mowing.
- Check fuel tank before starting engine. Do not fill gas tank indoors, when the engine is running or when the engine is hot. Allow the engine to cool for several minutes before filling the gas tank. Clean off any spilled gasoline before starting the engine.
- Always make wheel height adjustments before starting your mower. Never attempt to do this while the engine is running.
- Mow only in daylight or good artificial light.

OPERATION:

- Keep your eyes and mind on your mower and the area being cut. Do not let other interests distract you.
- Do not mow wet or slippery grass. Never run while operating your mower. Always be sure of your footing - keep a firm hold on the handles and walk.
- Do not put hands or feet near or under rotating parts. Keep clear of the discharge opening at all times.
- Always stop the engine whenever you leave or are not using your mower, or before crossing driveways, walks, roads, and any gravel-covered areas.
- Never direct discharge of material toward bystanders nor allow anyone near the mower while you are operating it.
- Before cleaning, inspecting, or repairing your mower, stop the engine and make absolutely sure the blade and all moving parts have stopped. Then disconnect the spark plug wire and keep it away from the spark plug to prevent accidental starting.

- Do not continue to run your mower if you hit a foreign object. Follow the procedure outlined above, then repair any damage before restarting and operating your mower.
- Do not change the governor settings or overspeed the engine. Engine damage or personal injury may result.
- Do not operate your mower if it vibrates abnormally. Excessive vibration is an indication of damage; stop the engine, safely check for the cause of vibration and repair as required.
- Do not run the engine indoors. Exhaust fumes are dangerous.
- Never cut grass by pulling the mower towards you. Mow across the face of slopes, never up and down or you might lose your footing. Do not mow excessively steep slopes. Use caution when operating the mower on uneven terrain or when changing directions - maintain good footing.
- Never operate your mower without proper guards, plates, grass catcher or other safety devices in place.

MAINTENANCE AND STORAGE:

- Check the blade and the engine mounting bolts often to be sure they are tightened properly.
- Check all bolts, nuts and screws at frequent intervals for proper tightness to be sure mower is in safe working condition.
- Keep all safety devices in place and working.
- To reduce fire hazard, keep the engine free of grass, leaves or excessive grease and oil.
- Check grass catcher often for deterioration and wear and replace worn bags. Use only replacement bags that are recommended by and comply with specifications of the manufacturer of your mower.
- Always keep a sharp blade on your mower.
- Allow engine to cool before storing in any enclosure.
- Never store mower with fuel in the tank inside a building where fumes may reach an open flame or an ignition source such as a hot water heater, space heater, clothes dryer, etc.



Look for this symbol to point out important safety precautions. It means CAUTION!!! BECOME ALERT!!! YOUR SAFETY IS INVOLVED.



CAUTION: Always disconnect spark plug wire and place wire where it cannot contact spark plug in order to prevent accidental starting when setting up, transporting, adjusting or making repairs.

⚠ WARNING ⚠

The engine exhaust from this product contains chemicals known to the State of California to cause cancer, birth defects, or other reproductive harm.

CONGRATULATIONS on your purchase of a Sears Lawn Mower. It has been designed, engineered and manufactured to give you the best possible dependability and performance.

Should you experience any problem you cannot easily remedy, please contact your nearest Sears Authorized Service Center/Department. We have competent, well-trained technicians and the proper tools to service or repair this lawn mower.

Please read and retain this manual. The instructions will enable you to assemble and maintain your lawn mower properly. Always observe the "SAFETY RULES".

MODEL NUMBER	917.386132
SERIAL NUMBER	_____
DATE OF PURCHASE	_____
THE MODEL AND SERIAL NUMBERS WILL BE FOUND ON A DECAL ATTACHED TO THE REAR OF THE LAWN MOWER HOUSING	
YOU SHOULD RECORD BOTH SERIAL NUMBER AND DATE OF PURCHASE AND KEEP IN A SAFE PLACE FOR FUTURE REFERENCE.	

PRODUCT SPECIFICATIONS

HORSEPOWER:	4.5
DISPLACEMENT:	11.5 CU. IN.
GASOLINE CAPACITY AND TYPE:	1.5 QUARTS UNLEADED REGULAR
OIL TYPE (API-SF/SG):	SAE 30 (ABOVE 32°F) SAE 5W-30 (BELOW 32°F)
OIL CAPACITY:	20 OZS.
SPARK PLUG: (GAP: .030")	CHAMPION RJ19LM
VALVE CLEARANCE:	INTAKE: .008 EXHAUST: .008
SOLID STATE IGNITION AIR GAP:	.0125 IN.
BLADE BOLT TORQUE:	35-40 FT. LBS.

MAINTENANCE AGREEMENT

A Sears Maintenance Agreement is available on this product. Contact your nearest Sears store for details.

CUSTOMER RESPONSIBILITIES

- Read and observe the safety rules.
- Follow a regular schedule in maintaining, caring for and using your lawn mower.
- Follow the instructions under "Customer Responsibilities" and "Storage" sections of this owner's manual.

LIMITED TWO YEAR WARRANTY ON CRAFTSMAN POWER MOWER

For two years from date of purchase, when this Craftsman Lawn Mower is maintained, lubricated, and tuned up according to the operating and maintenance instructions in the owner's manual, Sears will repair free of charge any defect in material or workmanship.

If this Craftsman Lawn Mower is used for commercial or rental purposes, this warranty applies for only 90 days from the date of purchase.

This Warranty does not cover:

- Expendable items which become worn during normal use, such as rotary mower blades, blade adapters, belts, air cleaners and spark plug.
- Repairs necessary because of operator abuse or negligence, including bent crankshafts and the failure to maintain the equipment according to the instructions contained in the owner's manual.

WARRANTY SERVICE IS AVAILABLE BY RETURNING THE CRAFTSMAN POWER MOWER TO THE NEAREST SEARS SERVICE CENTER/DEPARTMENT IN THE UNITED STATES. THIS WARRANTY APPLIES ONLY WHILE THIS PRODUCT IS IN USE IN THE UNITED STATES.

This Warranty gives you specific legal rights, and you may also have other rights which vary from state to state.

SEARS, ROEBUCK AND CO., D/817 WA, HOFFMAN ESTATES, ILLINOIS 60179

TABLE OF CONTENTS

SAFETY RULES	2
PRODUCT SPECIFICATIONS	3
CUSTOMER RESPONSIBILITIES	3, 11-13
WARRANTY	3
ASSEMBLY	6
OPERATION	8
MAINTENANCE SCHEDULE	11

SERVICE AND ADJUSTMENTS	14
STORAGE	15
TROUBLESHOOTING	21
REPAIR PARTS - LAWN MOWER	16-17
REPAIR PARTS - ENGINE	18-20
PARTS ORDERING/SERVICE	22

INDEX

A		E		Operation:	
Accessories	5	Engine:		Engine Control	9
Adjustments:		Air Filter	13	Grass Catcher	9
Carburetor	14	Oil Change	13	Mower	9
Engine Speed	14	Oil Level	13	Operator Presence	
Handle Height	14	Oil Type	13	Control Bar	9
Height of Cut	9	Starting	10	Options:	
Air Filter:		Stopping	10	Accessories	5
Replacement	13	Storage	15		
Service	13			R	
Assembly	6			Repair Parts:	
		F		Engine	18-20
		Fuel:		Lawn Mower	16-17
		Capacity	3	Responsibilities, Customer..	3, 11-13
		Storage	15		
		Type	9	S	
				Safety Rules	2
		H		Service and Adjustments	14
		Handle Adjustment:		Carburetor	14
		Assembly	6	Engine Speed	14
		Cutting Height	14	Handle	14
				Spark Plug	13
		L		Specifications	3
		Lubrication:		Speed Control:	
		Engine	13	Engine	14
		Lawn Mower	11	Starting the Engine	10
				Stopping the Engine	10
		M		Storage	15
		Maintenance Agreement	3		
		Maintenance Schedule	11	T	
		Mowing Tips	10	Trouble Shooting Chart	21
		O		W	
		Oil:		Warranty	3
		Engine	13		
		Storage	15		



LAWN MOWER ACCESSORIES

These accessories were available when this lawn mower was produced. They are also available at most Sears retail outlets and service centers. Most Sears stores can also order repair parts for you, when you provide the model number of your lawn mower. Some of these accessories may not apply to your lawn mower.

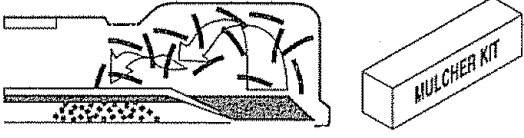
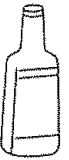
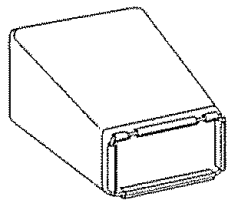
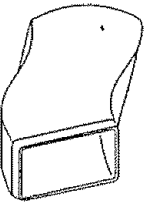
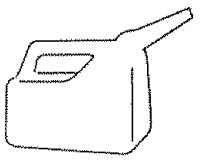
LAWN MOWER PERFORMANCE

 <p>CLIPPING DEFLECTOR FOR REAR DISCHARGE LAWN MOWERS</p>	 <p>MULCHER KITS</p>	 <p>STABILIZER</p>
 <p>GRASS CATCHERS FOR REAR DISCHARGE LAWN MOWERS</p>	 <p>GRASS CATCHERS FOR SIDE DISCHARGE LAWN MOWERS</p>	 <p>GAS CANS</p>

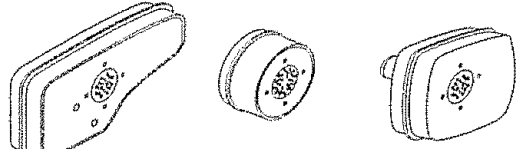
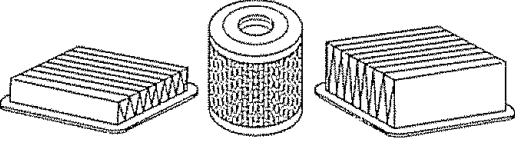
LAWN MOWER MAINTENANCE

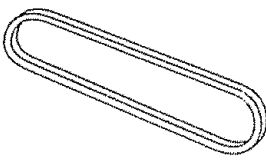
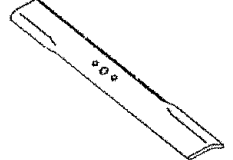
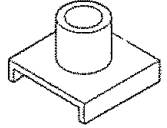
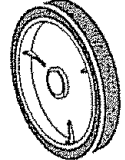
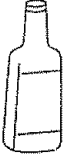
 <p>MUFFLERS</p>		 <p>AIR FILTERS</p>		 <p>SPARK PLUGS</p>
 <p>BELTS</p>	 <p>BLADES</p>	 <p>BLADE ADAPTERS</p>	 <p>WHEELS</p>	 <p>ENGINE OIL</p>

ASSEMBLY

Read these instructions and this manual in its entirety before you attempt to assemble or operate your new lawn mower. Your new lawn mower has been assembled at the factory with the exception of those parts left unassembled for shipping purposes. All parts such as nuts, washers, bolts, etc., necessary to complete the assembly have been placed in the parts bag. To ensure safe and proper operation of your lawn mower, all parts and hardware you assemble must be tightened securely. Use the correct tools as necessary to ensure proper tightness.

TO REMOVE LAWN MOWER FROM CARTON

- Remove loose parts included with mower
- Cut down two end corners of carton and lay end panel down flat.
- Remove all packing materials except padding between upper and lower handle and padding holding operator presence control bar to upper handle.
- Roll lawn mower out of carton and check carton thoroughly for additional loose parts.

HOW TO SET UP YOUR LAWN MOWER TO UNFOLD HANDLE (See Fig. 1)

IMPORTANT: UNFOLD HANDLES CAREFULLY SO AS NOT TO PINCH OR DAMAGE CONTROL CABLES

- Raise handles until lower handle section locks into place in mowing position.
- Raise upper handle section into place on lower handle, remove protective padding and tighten both handle knobs.
- Remove handle padding holding operator presence control bar to upper handle.
- Your lawn mower handle can be adjusted for your mowing comfort. Refer to "Adjust Handle" in the Service and Adjustment section of this manual.

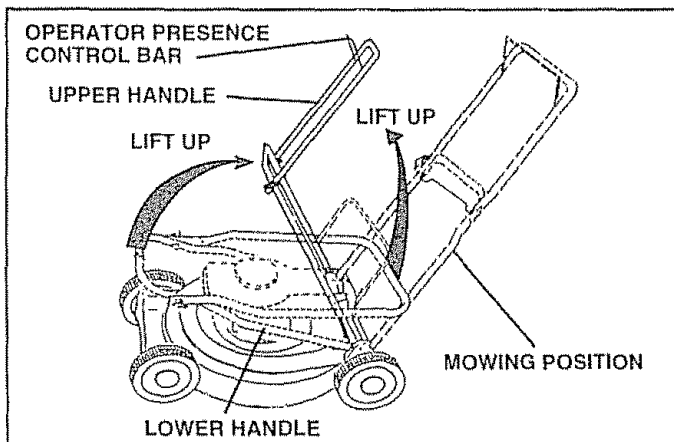

FIG. 1

TO INSTALL ATTACHMENTS (See Fig. 2)

Your lawn mower was shipped ready to be used as a mulcher. To convert to bagging or discharging:

- Open rear door and remove mulcher plug. Store mulcher plug in a safe place.
- You can now install catcher or optional clipping deflector.
- To return to mulching operation, install mulcher plug into discharge opening of mower.

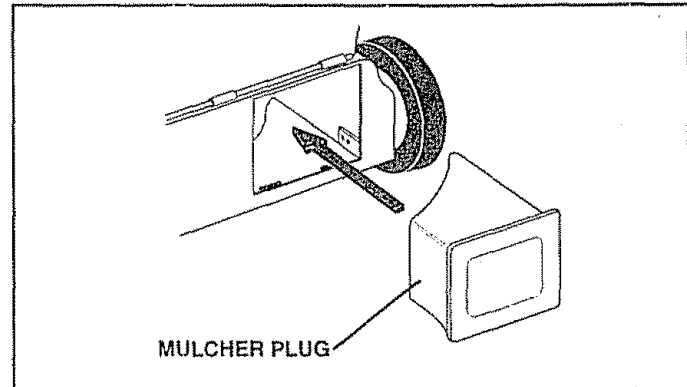

FIG. 2



CAUTION: Do not run your lawn mower without mulcher plug in place or approved clipping deflector or grass catcher in place. Never attempt to operate the lawn mower with the rear door removed or propped open.

ASSEMBLY

TO ASSEMBLE AND ATTACH GRASS CATCHER (See Figs. 3A thru 4)

- Insert leg of tubular frame through front opening of grass catcher and thread frame into sewn hem of bag.

NOTE: Keep bag hem gathered on the straight leg of the tubular frame.

- When frame comes out the other end of sewn hem, immediately work the end of frame down inside the bag as shown in inset.
- Slide sewn hem evenly around the tubular frame until both ends of frame are exposed out of the front opening.
- Assemble lower frame to tubular frame as shown. Be sure handle is outside of bag and frames are fully seated as shown in inset.
- Slip vinyl bindings over frame.

NOTE: If vinyl bindings are too stiff, hold them in warm water for a few minutes. If bag gets wet, let it dry before using.

- Close the flip lid. Flip lid must be closed while operating lawn mower.
- Lift the rear door on the mower housing and place the grass catcher frame onto the formed tabs on the rear door hinge bracket.
- The grass catcher is secured to the lawn mower housing when the rear door is lowered onto the grass catcher frame.

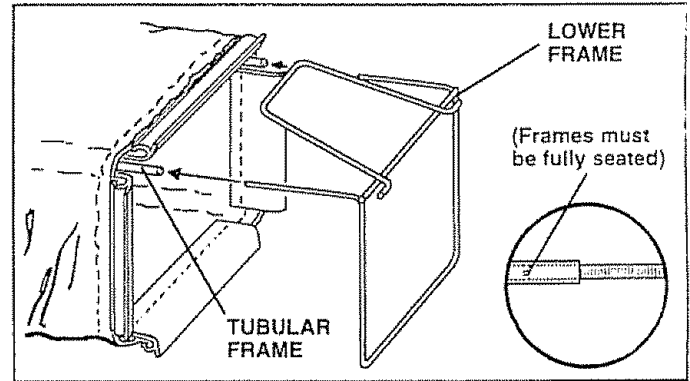

FIG. 3B

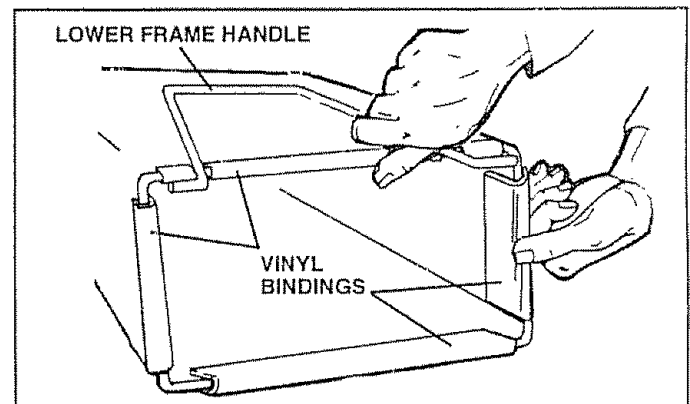

FIG. 3C

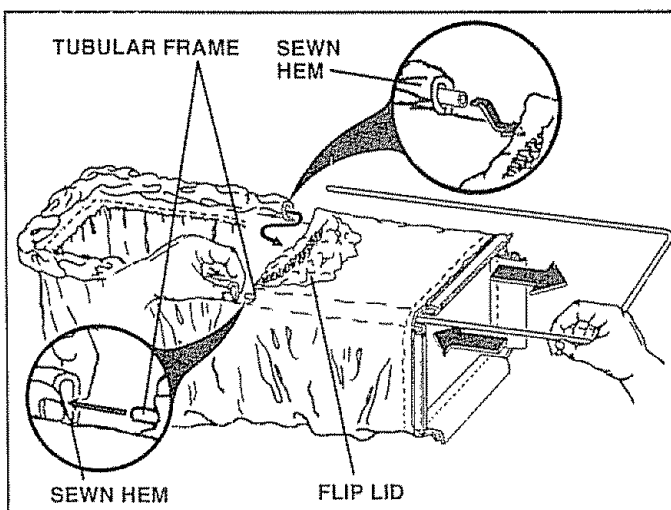
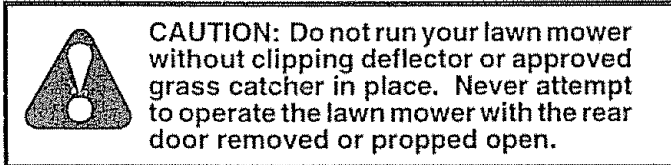

FIG. 3A

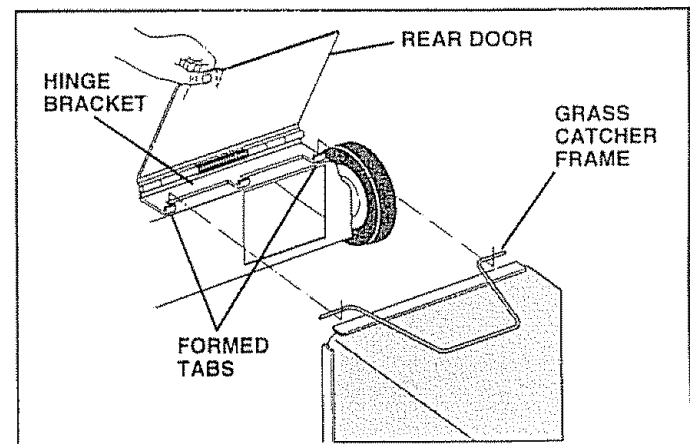

FIG. 4

OPERATION

KNOW YOUR LAWN MOWER

READ THIS OWNER'S MANUAL AND SAFETY RULES BEFORE OPERATING YOUR LAWN MOWER. Compare the illustrations with your lawn mower to familiarize yourself with the location of various controls and adjustments. Save this manual for future reference.

These symbols may appear on your lawn mower or in literature supplied with the product. Learn and understand their meaning.

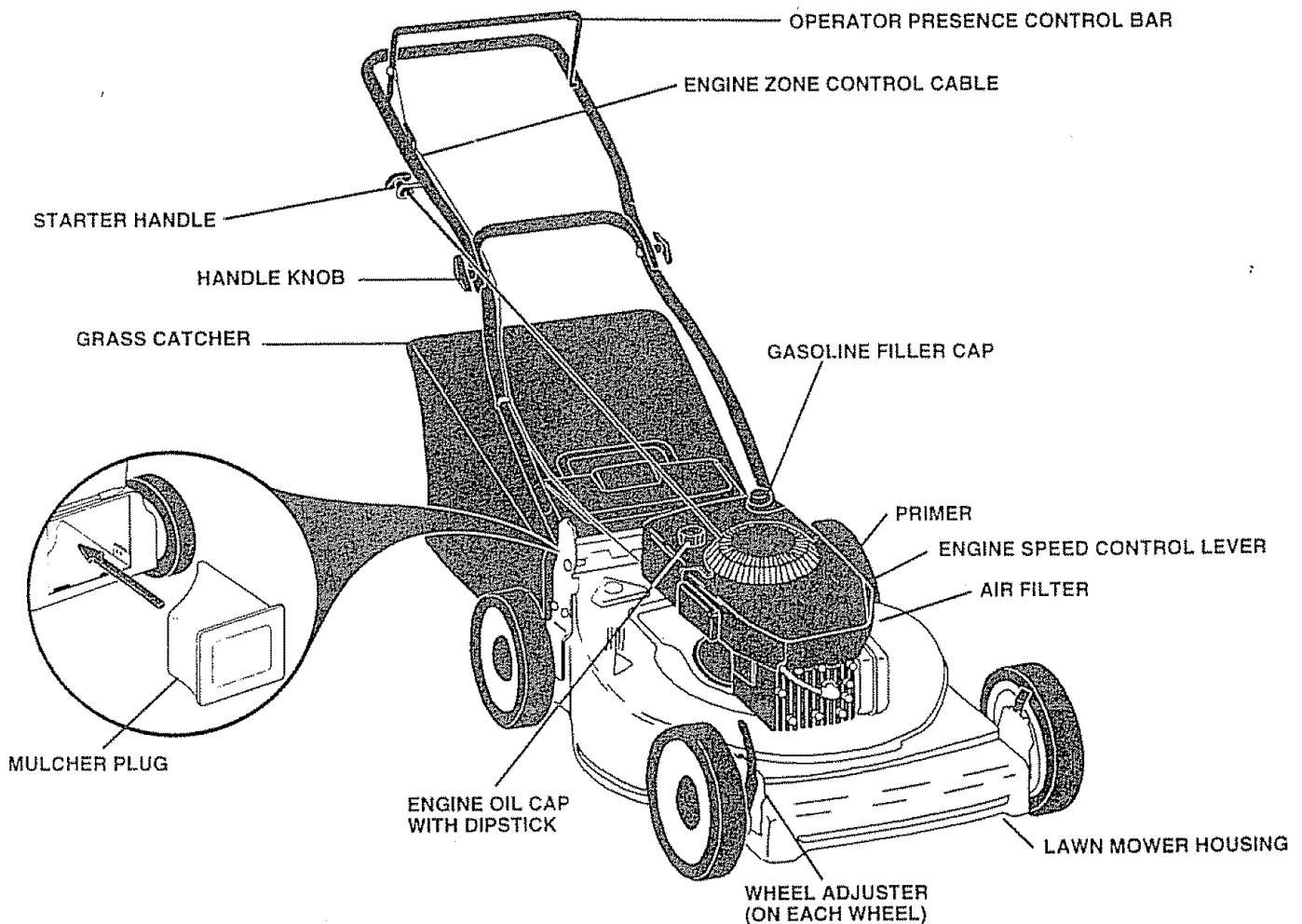
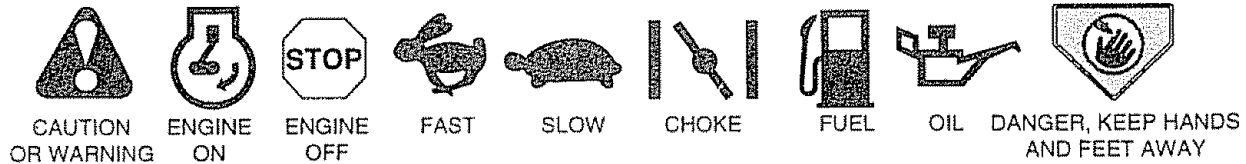

MEETS CPSC SAFETY REQUIREMENTS

Sears rotary walk-behind power lawn mowers conform to the safety standards of the American National Standards Institute and the U.S. Consumer Product Safety Commission. The blade turns when the engine is running.

OPERATOR PRESENCE CONTROL BAR - must be held down to the handle to start the engine. Release to stop the engine.

PRIMER - pumps additional fuel from the carburetor to the cylinder for use when starting a cold engine.

STARTER HANDLE - used for starting the engine.

ENGINE SPEED CONTROL - located on the side of the engine which allows you to select either fast (🐇) or slow (🐌) engine speed.

MULCHER PLUG - located at the discharge opening must be removed when converting to bagging or discharging operation.

OPERATION



The operation of any lawn mower can result in foreign objects thrown into the eyes, which can result in severe eye damage. Always wear safety glasses or eye shields while operating your lawn mower or performing any adjustments or repairs. We recommend a wide vision safety mask over the spectacles or standard safety glasses.

HOW TO USE YOUR LAWN MOWER

ENGINE SPEED CONTROL (See Fig. 5)

The engine speed is controlled by a lever located on the side of the engine. Fast (👉) position is for starting the engine, normal cutting, and better grass bagging. Slow (👈) position is for light cutting, trimming and fuel economy.

ENGINE ZONE CONTROL



CAUTION: Federal regulations require an engine control to be installed on this lawn mower in order to minimize the risk of blade contact injury. Do not under any circumstances attempt to defeat the function of the operator control. The blade turns when the engine is running.

- Your lawn mower is equipped with an operator presence control bar which requires the operator to be positioned behind the lawn mower handle to start and operate the lawn mower.

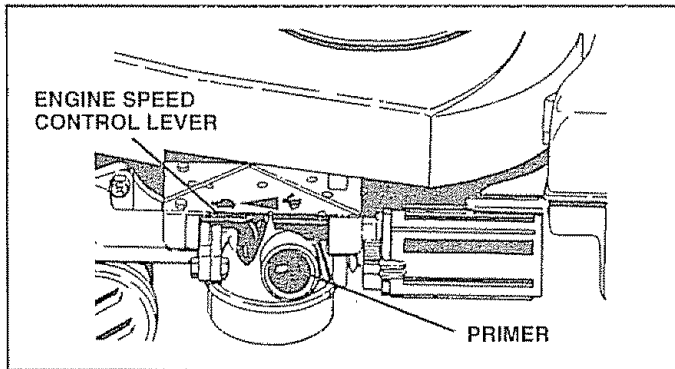

FIG. 5

TO ADJUST CUTTING HEIGHT (See Fig. 6)

- Raise wheels for low cut and lower wheels for high cut.
- Adjust cutting height to suit your requirements. Medium position is best for most lawns.
- To change cutting height, squeeze adjuster lever toward wheel. Move wheel up or down to suit your requirements. Be sure all wheels are in the same setting.

NOTE: Adjuster is properly positioned when plate tab inserts into hole in lever. Also, 9-position adjusters (if so equipped) allow lever to be positioned between the plate tabs.

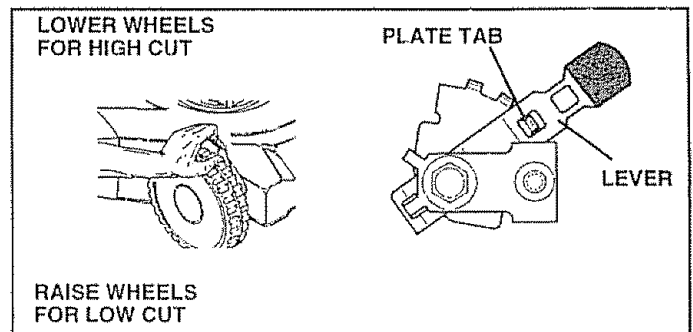

FIG. 6

TO EMPTY GRASS CATCHER (See Fig. 7)

- Lift up on grass catcher using the frame handle.
- Remove grass catcher with clippings from under lawn mower handle.
- Empty clippings from bag using both frame handle and bag handle.

NOTE: Do not drag the bag when emptying; it will cause unnecessary wear.

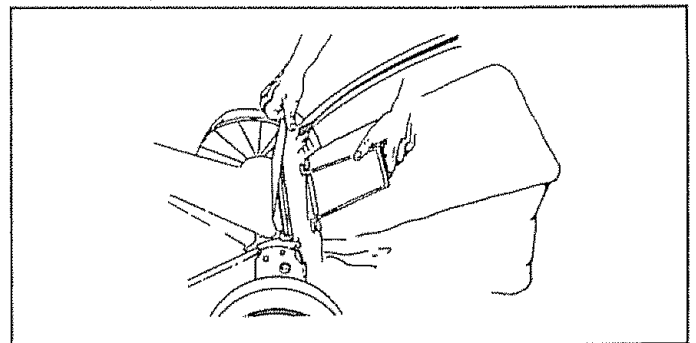

FIG. 7

BEFORE STARTING ENGINE OIL

Your lawn mower is shipped without oil in the engine.

- Be sure mower is level and area around oil fill is clean.
- Remove engine oil cap w/dipstick and fill to the full line on the dipstick.
- Use 20 ozs. of oil. For type and grade of oil to use, see "ENGINE" in Customer Responsibilities section of this manual.
- Pour oil slowly. Do not over fill.
- Check oil level before each use. Add oil if needed. Fill to full line on dipstick.
- To read proper level, tighten engine oil cap each time.
- Reinstall engine oil cap and tighten.
- After the first two (2) hours of mowing, change the oil, and every 25 hours thereafter. You may need to change the oil more often under dusty, dirty conditions.

OPERATION

GAS

- Fill fuel tank. Use fresh, clean, regular unleaded gasoline with a minimum of 87 octane. Do not mix oil with gasoline. Purchase fuel in quantities that can be used within 30 days to assure fuel freshness.

WARNING: Experience indicates that alcohol blended fuels (called gasohol or using ethanol or methanol) can attract moisture which leads to separation and formation of acids during storage. Acidic gas can damage the fuel system of an engine while in storage. To avoid engine problems, the fuel system should be emptied before storage of 30 days or longer. Drain the fuel tank, start the engine and let it run until fuel lines and carburetor are empty. Use fresh fuel next season. See Storage Instructions for additional information. Never use engine or carburetor cleaner products in fuel tank or permanent damage may occur.

TO START ENGINE

- To start a cold engine, push primer five (5) times before trying to start. Use a firm push. This step is not usually necessary when starting an engine which has already run for a few minutes.
- Push engine speed control lever to fast (👉) position.
- Hold operator presence control bar down to the handle and pull starter handle quickly. Do not allow starter rope to snap back.
- To stop engine, release operator presence control bar.

NOTE: In cooler weather it may be necessary to repeat priming steps. In warmer weather over priming may cause flooding and engine will not start. If you do flood engine, wait a few minutes before attempting to start and do not repeat priming steps.

MOWING TIPS

- Under certain conditions, such as very tall grass, it may be necessary to raise the height of cut to reduce pushing effort and to keep from overloading the engine and leaving clumps of grass clippings.
- For extremely heavy cutting, reduce the width of cut and raise the rear of the lawn mower housing one (1) wheel adjuster setting higher than the front for better discharge of grass.
- For better grass bagging and most cutting conditions, the engine speed should be set in the fast (👉) position.
- When using a rear discharge lawn mower in moist, heavy grass, clumps of cut grass may not enter the grass catcher. Reduce ground speed (pushing speed) and/or run the lawn mower over the area a second time.
- If a trail of grass clippings is left on the right side of a rear discharge lawn mower, mow in a clockwise direction with a small overlap to collect the clippings on the next pass.
- Keep top of engine around starter clear and clean of grass clippings and chaff. This will help engine air flow and extend engine life.
- Pores in cloth grass catchers can become filled with dirt and dust with use and catchers will collect less grass. To prevent this, regularly hose catchers off with water and let dry before using.

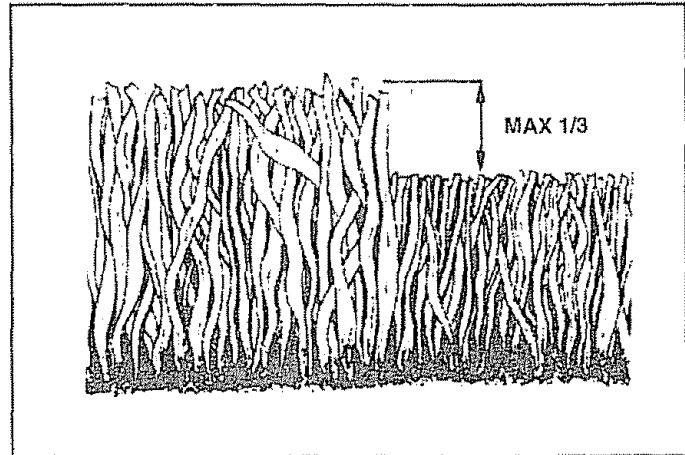

FIG. 8

MULCHING MOWING TIPS

IMPORTANT: FOR BEST PERFORMANCE, KEEP MOWER HOUSING FREE OF BUILT-UP GRASS AND TRASH. CLEAN UNDERSIDE OF MOWER HOUSING AFTER EACH USE. SEE "CLEANING" IN CUSTOMER RESPONSIBILITIES SECTION OF THIS MANUAL.

- The special mulching blade will recut the grass clippings many times and reduce them in size so that as they fall onto the lawn they will disperse into the grass and not be noticed. Also, the mulched grass will biodegrade quickly to provide nutrients for the lawn. Always mulch with your highest engine (blade) speed as this will provide the best recutting action of the blades.
- Avoid cutting your lawn when it is wet. Wet grass tends to form clumps and interferes with the mulching action. The best time to mow your lawn is the early afternoon. At this time the grass has dried and the newly cut area will not be exposed to the direct sun.
- For best results, adjust the lawn mower cutting height so that the lawn mower cuts off only the top one-third of the grass blades (See Fig. 8). If the lawn is overgrown it will be necessary to raise the height of cut to reduce pushing effort and to keep from overloading the engine and leaving clumps of mulched grass. For extremely heavy mulching, reduce your width of cut, mow slowly and raise the rear of the lawn mower one wheel adjuster setting higher than the front.
- Certain types of grass and grass conditions may require that an area be mulched a second time to completely hide the clippings. When doing a second cut, mow across or perpendicular to the first cut path.
- Change your cutting pattern from week to week. Mow north to south one week then change to east to west the next week. This will help prevent matting and graining of the lawn.

CUSTOMER RESPONSIBILITIES

MAINTENANCE SCHEDULE FILL IN DATES AS YOU COMPLETE REGULAR SERVICE		SERVICE DATES					
		BEFORE EACH USE	AFTER EACH USE	FIRST 2 HOURS	EVERY 10 HOURS	EVERY 25 HOURS OR EVERY SEASON	BEFORE STORAGE
M O W E R	Check for Loose Fasteners	✓					✓
	Clean/Inspect Grass Catcher (If Equipped)	✓	✓				✓
	Clean Lawn Mower		✓				✓
	Clean Under Drive Cover (Power-Propelled Mowers)			✓			
	Check drive belt/pulleys (Power-Propelled Mowers)				✓		
	Check/Sharpen/Replace Blade				✓ ₃		
	Lubrication Chart				✓	✓	
	Clean Battery/Recharge (Electric Start Mowers)				✓	✓ ₄	
E N G I N E	Check Engine Oil Level	✓					
	Change Engine Oil		✓		✓ _{1,2}		
	Clean Air Filter				✓		
	Inspect Muffler				✓		
	Clean or Replace Spark Plug				✓		
	Replace Air Filter Paper Cartridge				✓ ₂		

- 1 - Change more often when operating under a heavy load or in high ambient temperatures.
- 2 - Service more often when operating in dirty or dusty conditions.
- 3 - Replace blades more often when mowing in sandy soil.
- 4 - Charge 48 hours at end of season.

GENERAL RECOMMENDATIONS

The warranty on this lawn mower does not cover items that have been subjected to operator abuse or negligence. To receive full value from the warranty, operator must maintain mower as instructed in this manual.

Some adjustments will need to be made periodically to properly maintain your unit.

All adjustments in the Service and Adjustments section of this manual should be checked at least once each season.

- Once a year, replace the spark plug, replace air filter element and check blade for wear. A new spark plug and clean/new air filter element assures proper air-fuel mixture and helps your engine run better and last longer.
- Follow the maintenance schedule in this manual.

BEFORE EACH USE

- Check engine oil level
- Check for loose fasteners.

LUBRICATION

Keep unit well lubricated (See "LUBRICATION CHART").

LUBRICATION CHART

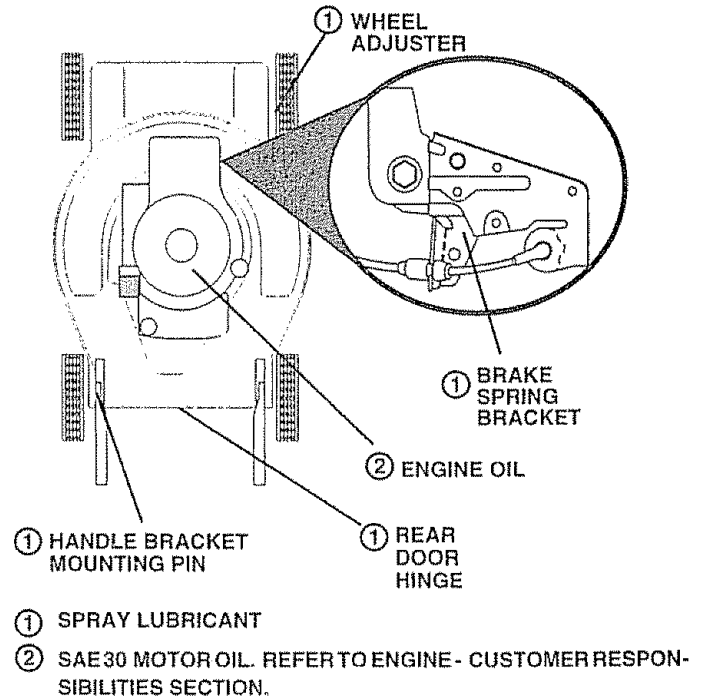

IMPORTANT: DO NOT OIL OR GREASE PLASTIC WHEEL BEARINGS. VISCOUS LUBRICANTS WILL ATTRACT DUST AND DIRT THAT WILL SHORTEN THE LIFE OF THE SELF LUBRICATING BEARINGS. IF YOU FEEL THEY MUST BE LUBRICATED, USE ONLY A DRY, POWDERED GRAPHITE TYPE LUBRICANT SPARINGLY.

CUSTOMER RESPONSIBILITIES

LAWN MOWER

Always observe safety rules when performing any maintenance.

TIRES

- Keep tires free of gasoline, oil, or insect control chemicals which can harm rubber.
- Avoid stumps, stones, deep ruts, sharp objects and other hazards that may cause tire damage.

BLADE CARE

For best results, mower blade must be kept sharp. Replace bent or damaged blades.

TO REMOVE BLADE (See Fig. 9)

- Disconnect spark plug wire from spark plug and place wire where it cannot come in contact with spark plug.
- Turn lawn mower on its side. Make sure air filter and carburetor are up.
- Use a wood block between blade and mower housing to prevent blade from turning when removing blade bolt.
- Protect your hands with gloves and/or wrap blade with heavy cloth.
- Remove blade bolt by turning counter-clockwise. Use a 9/16" box or open-end wrench.
- Remove blade and attaching hardware (bolt, lock washer and hardened washer).

NOTE: Remove the blade adapter and check the key inside hub of blade adapter. The key must be in good condition to work properly. Replace adapter if damaged.

TO REPLACE BLADE (See Fig. 9)

- Position the blade adapter on the engine crankshaft. Be sure key in adapter and keyway in crankshaft are aligned.
- Position blade on the blade adapter aligning the two (2) holes in the blade with the raised lugs on the adapter.
- Be sure the trailing edge is up toward the engine.
- Install the blade bolt with the lock washer and hardened washer into blade adapter and crankshaft.
- Use block of wood between blade and lawn mower housing and tighten the blade bolt, turning clockwise.
- The recommended tightening torque is 35-40 ft. lbs.

IMPORTANT: BLADE BOLT IS GRADE 8 HEAT TREATED.

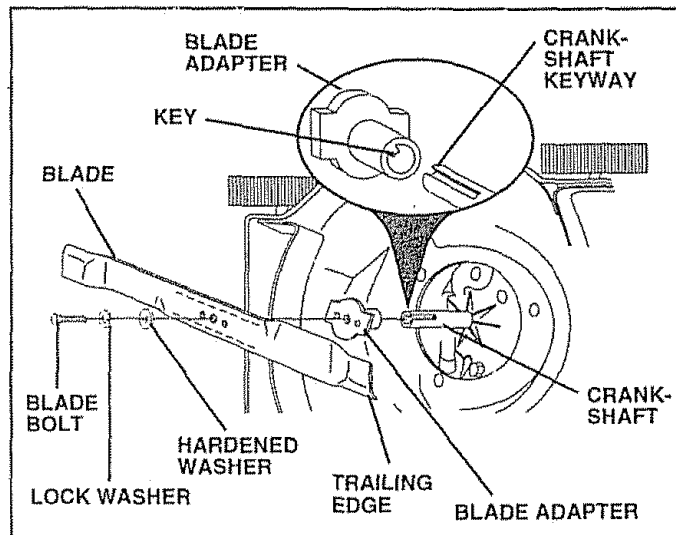

FIG. 9

NOTE: We do not recommend sharpening blade - but if you do, be sure the blade is balanced.

TO SHARPEN BLADE

Care should be taken to keep the blade balanced. An unbalanced blade will cause eventual damage to lawn mower or engine.

- The blade can be sharpened with a file or on a grinding wheel. Do not attempt to sharpen while on the mower.
- To check blade balance, drive a nail into a beam or wall. Leave about one inch of the straight nail exposed. Place center hole of blade over the head of the nail. If blade is balanced, it should remain in a horizontal position. If either end of the blade moves downward, sharpen the heavy end until the blade is balanced.

GRASS CATCHER

- The grass catcher may be hosed with water, but must be dry when used.
- Check your grass catcher often for damage or deterioration. Through normal use it will wear. If catcher needs replacing, replace only with a manufacturer approved replacement catcher. Give the lawn mower model number when ordering.

CUSTOMER RESPONSIBILITIES

ENGINE LUBRICATION

Use only high quality detergent oil rated with API service classification SF or SG. Select the oil's SAE viscosity grade according to your expected operating temperature.

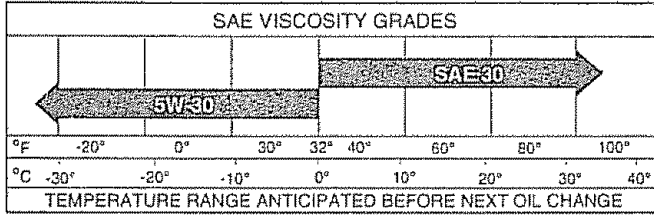

NOTE: Although multi-viscosity oils (5W30, 10W30 etc.) improve starting in cold weather, these multi-viscosity oils will result in increased oil consumption when used above 32°F. Check your engine oil level more frequently to avoid possible engine damage from running low on oil.

Change the oil after the first two hours of operation and every 25 hours thereafter or at least once a year if the lawn mower is not used for 25 hours in one year.

Check the crankcase oil level before starting the engine and after each five (5) hours of continuous use. Tighten oil plug securely each time you check the oil level.

TO CHANGE ENGINE OIL (See Fig. 10)

NOTE: Before tipping lawn mower to drain oil, drain fuel tank by running engine until fuel tank is empty.

- Disconnect spark plug wire from spark plug and place wire where it cannot come in contact with spark plug.
- Remove engine oil cap; lay aside on a clean surface.
- Tip lawn mower on its side and drain oil into a suitable container. Rock lawn mower back and forth to remove any oil trapped inside of engine.
- Wipe off any spilled oil on lawn mower and on side of engine.
- Fill engine with oil. Fill only to the "FULL" line on the dipstick. **DO NOT OVER FILL.**
- Replace engine oil cap.
- Reconnect spark plug wire to spark plug.

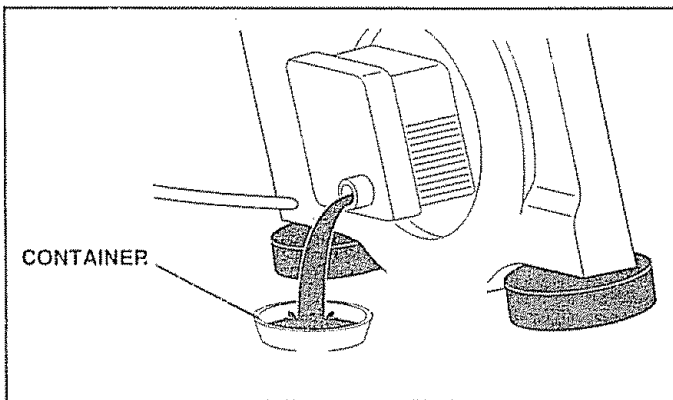

FIG. 10

AIR FILTER

Your engine will not run properly and may be damaged by using a dirty air filter.

Replace the air filter every year, more often if you mow in very dusty, dirty conditions. Do not wash air filter.

TO CHANGE AIR FILTER (See Fig. 11)

- Remove the air filter cover by turning counterclockwise to the stop and pull away from collar.
- Remove filter from inside of cover.
- Clean the inside of the cover and the collar to remove any dirt accumulation.
- Insert new filter into cover.
- Put air filter cover and filter into collar aligning the tab with the slot.
- Push in on cover and turn clockwise to tighten.

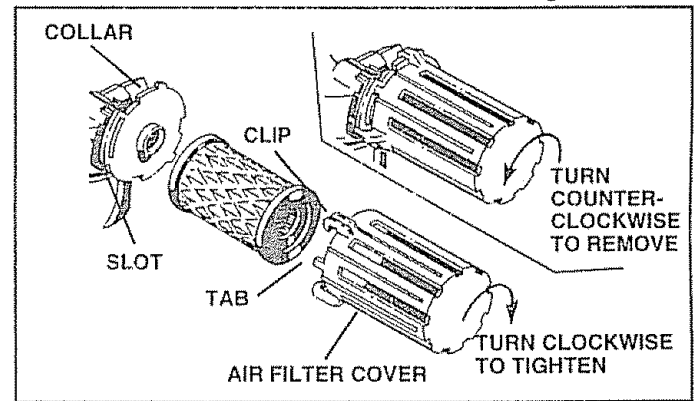

FIG. 11

MUFFLER

Inspect and replace corroded muffler as it could create a fire hazard and/or damage.

SPARK PLUG

Change your spark plug each year to make your engine start easier and run better. Set spark plug gap at .030 inch.

CLEANING

IMPORTANT: FOR BEST PERFORMANCE, KEEP MOWER HOUSING FREE OF BUILT-UP GRASS AND TRASH. CLEAN UNDERSIDE OF MOWER HOUSING AFTER EACH USE.



CAUTION: Disconnect spark plug wire from spark plug and place wire where it cannot come in contact with the spark plug.

- Turn lawn mower on its side. Make sure air filter and carburetor are up. Clean the underside of your lawn mower by scraping to remove build-up of grass and trash.
- Clean engine often to keep trash from accumulating. A clogged engine runs hotter and shortens engine life.
- Keep finished surfaces and wheels free of all gasoline, oil, etc.
- We **DO NOT** recommend using a garden hose to clean lawn mower unless the electrical system, muffler, air filter and carburetor are covered to keep water out. Water in engine can result in shortened engine life.

SERVICE AND ADJUSTMENTS



CAUTION: BEFORE PERFORMING ANY SERVICE OR ADJUSTMENTS:

- Release control bar.
- Make sure the blade and all moving parts have completely stopped.
- Disconnect spark plug wire from spark plug and place where it cannot come in contact with plug.

LAWN MOWER

TO ADJUST CUTTING HEIGHT

See "TO ADJUST CUTTING HEIGHT" in the Operation section of this manual.

REAR DEFLECTOR

The rear deflector, attached between the rear wheels of your lawn mower, is provided to minimize the possibility that objects will be thrown out the rear of the lawn mower into the operator's mowing position.

If the rear deflector becomes damaged, it should be replaced.

TO ADJUST HANDLE (See Figs. 12 Thru 14)

Your lawn mower handle can be raised or lowered for your mowing comfort. Four (4) positions are available: high, medium high, medium low and low. Handles are shipped mounted in the medium low position.

- To change from medium low to medium high position, the upper and lower handle sections will have to be turned over (See Fig. 12B).
- Remove the cable clips.
- Remove the controls and operator presence control bar from the upper handle.
- Remove the starter rope guide from the lower handle.
- Remove hairpin cotter.
- Disconnect the lower handle from the handle brackets (See Fig. 14).
- Turn the handle over and reassemble the hairpin cotter that have been removed.
- Reassemble the starter rope guide.
- Reassemble the controls and the operator presence control bar to the upper handle.

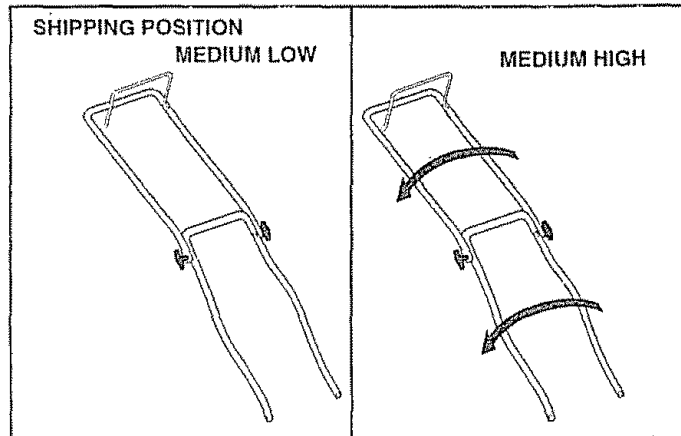

FIG. 12A

FIG. 12B

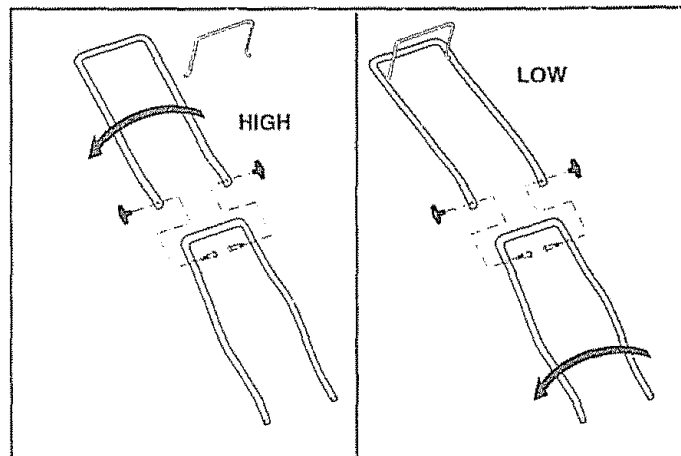

FIG. 13A

FIG. 13B

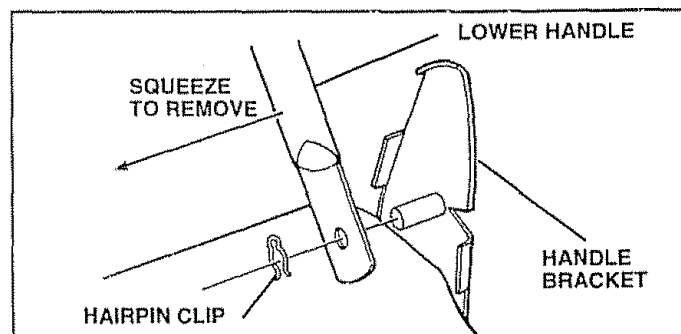



FIG. 14



CAUTION: The operator presence control bar must pivot freely to permit blade brake engagement when control bar is released. Do not over tighten the fasteners holding the controls to the upper handle.

- To change from medium low to high position only the upper handle section will have to be turned over (See Fig. 13A).
- To change from medium low to low position, only the lower handle section will have to be turned over (See Fig. 13B).

ENGINE CARBURETOR

Your carburetor has a non-adjustable fixed main jet for mixture control. If your engine does not operate properly due to suspected carburetor problems, take your lawn mower to an authorized service center for repair or adjustment.

ENGINE SPEED

Your engine speed has been factory set. Do not attempt to increase engine speed or it may result in personal injury. If you believe that the engine is running too fast or too slow, take your lawn mower to an authorized service center for repair and adjustment.

STORAGE

Immediately prepare your lawn mower for storage at the end of the season or if the unit will not be used for 30 days or more.

LAWN MOWER

When lawn mower is to be stored for a period of time, clean it thoroughly, remove all dirt, grease, leaves, etc. Store in a clean, dry area.

- Clean entire lawn mower (See "CLEANING" in the Customer Responsibilities section of this manual).
- Lubricate as shown in the Customer Responsibilities section of this manual.
- Be sure that all nuts, bolts, screws, and pins are securely fastened. Inspect moving parts for damage, breakage and wear. Replace if necessary.
- Touch up all rusted or chipped paint surfaces; sand lightly before painting.

HANDLE (See Fig. 15)

You can fold your lawn mower handle for storage.

- Squeeze the bottom ends of the lower handle toward each other until the lower handle clears the handle bracket, then move handle forward.
- Loosen upper handle mounting bolts enough to allow upper handle to be folded back.

IMPORTANT: WHEN FOLDING THE HANDLE FOR STORAGE OR TRANSPORTATION, BE SURE TO FOLD THE HANDLE AS SHOWN OR YOU MAY DAMAGE THE CONTROL CABLES.

- When setting up your handle from the storage position, the lower handle will automatically lock into the mowing position.

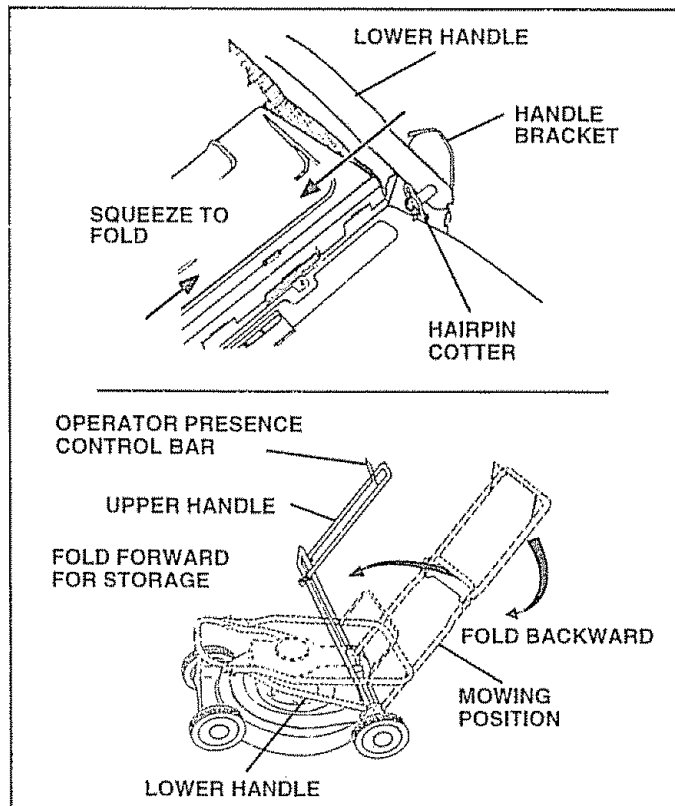

FIG. 15

ENGINE FUEL SYSTEM

IMPORTANT: IT IS IMPORTANT TO PREVENT GUM DEPOSITS FROM FORMING IN ESSENTIAL FUEL SYSTEM PARTS SUCH AS CARBURETOR, FUEL FILTER, FUEL HOSE, OR TANK DURING STORAGE. ALSO, EXPERIENCE INDICATES THAT ALCOHOL BLENDED FUELS (CALLED GASOHOL OR USING ETHANOL OR METHANOL) CAN ATTRACT MOISTURE WHICH LEADS TO SEPARATION AND FORMATION OF ACIDS DURING STORAGE. ACIDIC GAS CAN DAMAGE THE FUEL SYSTEM OF AN ENGINE WHILE IN STORAGE.

- Drain the fuel tank.
- Start the engine and let it run until the fuel lines and carburetor are empty.
- Never use engine or carburetor cleaner products in the fuel tank or permanent damage may occur.
- Use fresh fuel next season.

NOTE: Fuel stabilizer is an acceptable alternative in minimizing the formation of fuel gum deposits during storage. Add stabilizer to gasoline in fuel tank or storage container. Always follow the mix ratio found on stabilizer container. Run engine at least 10 minutes after adding stabilizer to allow the stabilizer to reach the carburetor. Do not drain the gas tank and carburetor if using fuel stabilizer.

ENGINE OIL

Drain oil (with engine warm) and replace with clean engine oil. (See "ENGINE" in the Customer Responsibilities section of this manual).

CYLINDER

- Remove spark plug.
- Pour one ounce (29 ml) of oil through spark plug hole into cylinder.
- Pull starter handle slowly a few times to distribute oil.
- Replace with new spark plug.

OTHER

- Do not store gasoline from one season to another.
- Replace your gasoline can if your can starts to rust. Rust and/or dirt in your gasoline will cause problems.
- If possible, store your unit indoors and cover it to give protection from dust and dirt.
- Cover your unit with a suitable protective cover that does not retain moisture. Do not use plastic. Plastic cannot breathe which allows condensation to form and will cause your unit to rust.

IMPORTANT: NEVER COVER MOWER WHILE ENGINE AND EXHAUST ARE STILL WARM.



CAUTION: Never store the lawn mower with gasoline in the tank inside a building where fumes may reach an open flame or spark. Allow the engine to cool before storing in any enclosure.

REPAIR PARTS

CRAFTSMAN 20" ROTARY LAWN MOWER -- MODEL NO. 917.386132

16

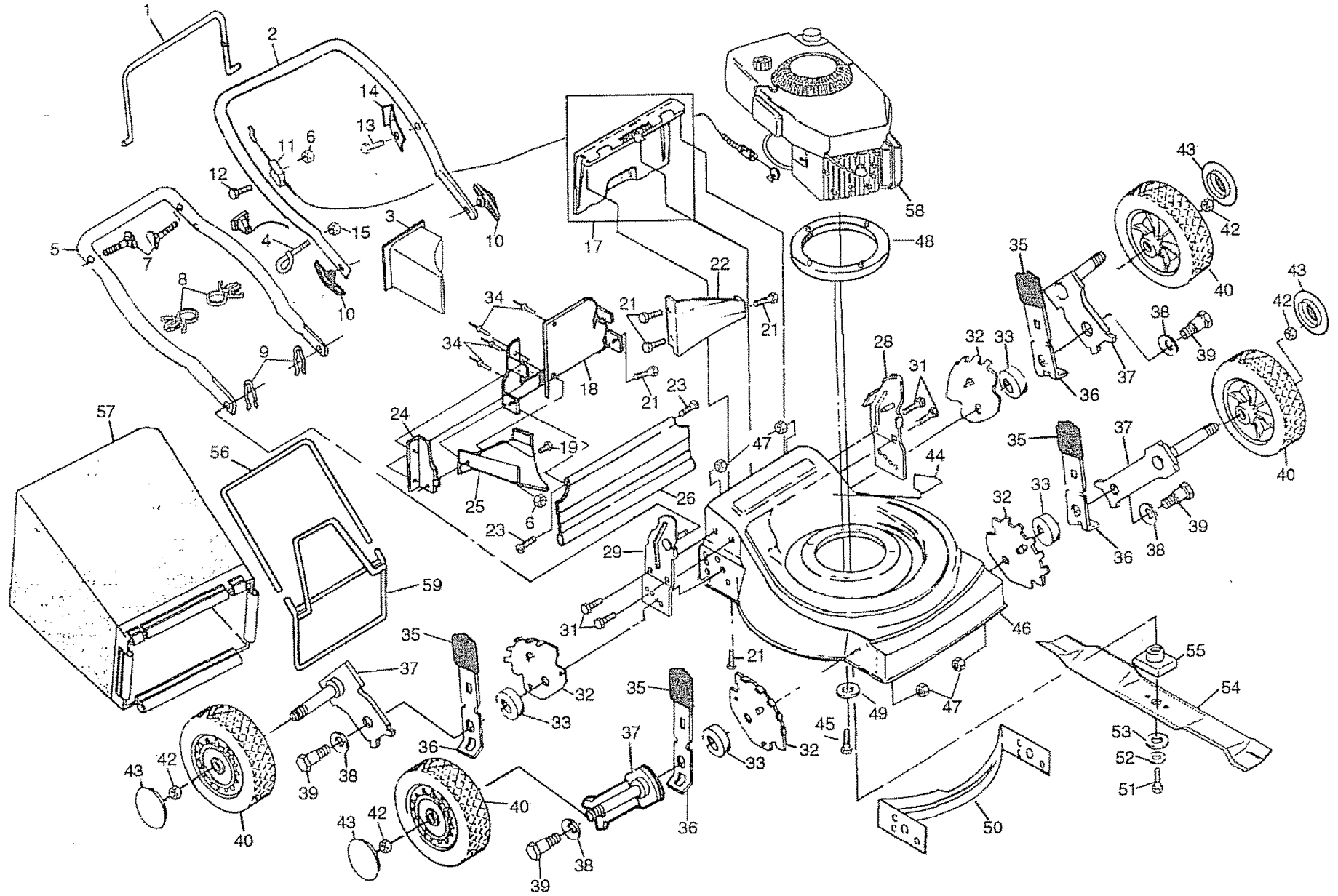

REPAIR PARTS

CRAFTSMAN 20" ROTARY LAWN MOWER - - MODEL NO. 917.386132

KEY NO.	PART NO.	DESCRIPTION	KEY NO.	PART NO.	DESCRIPTION
1	86902	Control Bar	36	700331X004	Selector Spring
2	133088X479	Upper Handle	37	145935X004	Axle Arm Assembly
3	150424	Mulcher Plug	38	62335	Belleville Washer
4	132001	Rope Guide	39	142748	Shoulder Bolt
5	151516X479	Lower Handle	40	151157	Wheel and Tire Assembly
6	STD541425	Locknut 1/4-20	42	83923	Hex Flange Locknut
7	131959	Handle Bolt	43	77400	Hubcap
8	151517	Cable Clip	44	85463	Danger Decal
9	51793	Hairpin Cotter	45	850999	Hex Head Thread Rolling Screw 3/8-16
10	136376	Handle Knob	46	48395	Lawn Mower Housing (Incl. Key #18, 22, 24, 44, 50)
11	130861	Engine Zone Control Cable	47	751592	Locknut 3/8-16
12	74350424	Hex Head Bolt 1/4-20 x 1-1/2	48	850988	Spacer
13	750097	Hex Washer Head Screw 10-24 x 1/2	49	53998	Washer
14	850733X004	Up-Stop Bracket	50	700938X479	Front Baffle
15	73510400	Keps Locknut 1/4-20	51	851084	Hex Head Machine Screw 3/8-24 x 1-3/8 (Grd. 8)
17	147613	Rear Door Assembly Kit	52	850263	Helical Lockwasher 3/8
18	700357X479	Back Plate	53	851074	Washer
19	150050	Self Tapping Screw 10-24 x 5/8	54	145106	Blade 20"
21	54583	Hex Head Tapping Screw 1/4-20 x 1/2	55	851514	Blade Adapter
22	700063X479	Rear Baffle	56	144748	Tube Frame
23	88652	Hinge Screw 1/4-20 x 1-1/4	57	149844	Grass Bag
24	700363X479	Side Baffle	58	151198	Engine - Craftsman Model No.143.964512
25	144875X479	Discharge Baffle	59	144747	Throat Frame
26	140657	Rear Deflector	--	156050	Owner's Manual
28	151512X479	Handle Bracket Assembly (Left)	Available accessories not included with lawn mower:		
29	151511X479	Handle Bracket Assembly (Right)	<u>71</u>	33723	Hi-Wheel Kit
31	150078	Screw 5/16-18 x 3/4	<u>71</u>	33623	Gas Can (2.5 gal.)
32	700325X007	Wheel Adjusting Bracket	<u>71</u>	33500	Fuel Stabilizer
33	146630	Spacer	<u>71</u>	33300	SAE 30W Oil (20 oz.)
34	128415	Pop Rivet	<u>71</u>	33417	Dust Shield
35	87877	Selector Knob	<u>71</u>	33316	Mower Cover

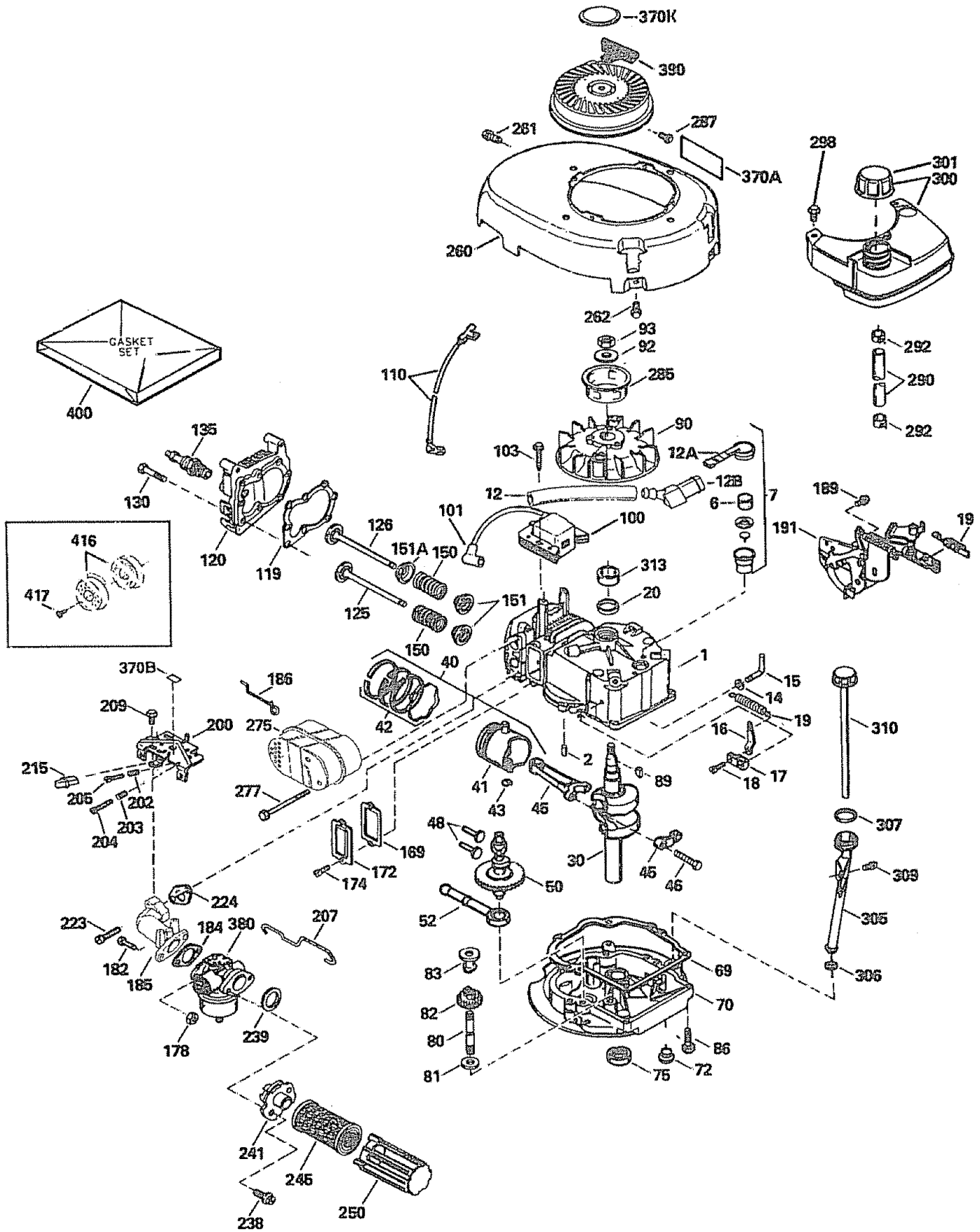

CRAFTSMAN 4-CYCLE ENGINE

MODEL NUMBER 143.964512

REF NO.	PART NO.	DESCRIPTION	REF NO.	PART NO.	DESCRIPTION
1	36774	Cylinder (Incl. 2 & 20)	184	26756	* Carburetor To Intake Pipe Gasket
2	26727	Dowel Pin	185	36785	Intake Pipe
6	33734	Breather Element	186	34358	Governor Link
7	36557	Breather Ass'y. (Incl. 6 & 12A)	189	650839	Screw, 1/4-20 x 3/8"
12	36775	Breather Tube	191	36559	S.E. Brake Bracket (Incl. 195)
12A	36558	Breather Cover & Tube (Incl. 12B)	195	610973	Terminal
12B	36694	Breather Tube Elbow	200	35727	Control Bracket (Incl. 202 thru 205)
14	28277	Washer	202	36482	Compression Spring
15	30589	Governor Rod (Incl. 14)	203	31342	Compression Spring
16	34839A	Governor Lever	204	650549	Screw, 5-40 x 7/16"
17	31335	Governor Lever Clamp	205	650777	Screw, 6-32 x 21/32"
18	650548	Screw, 8-32 x 5/16"	207	34336	Throttle Link
19	36281	Extension Spring	209	30200	Screw, 10-24 x 9/16"
20	32600	Oil Seal	215	32410	Control Knob
30	36793	Crankshaft	223	650451	Screw, 1/4-20 x 1"
40	40004	Piston, Pin & Ring Set (Std.)	224	36786	* Intake Pipe Gasket
40	40005	Piston, Pin & Ring Set (.010" OS)	238	650932	Screw, 10-32 x 49/64"
41	36070	Piston & Pin Ass'y. (Std.) (Incl. 43)	239	34338	* Air Cleaner Gasket
41	36071	Piston & Pin Ass'y. (.010" OS)	241	35797	Air Cleaner Collar
		(Incl. 43)	245	35066	Air Cleaner Filter
41	36072	Piston & Pin Ass'y. (.020" OS)	250	35065	Air Cleaner Cover
		(Incl. 43)	260	36794	Blower Housing
42	40006	Ring Set (Std.)	261	30200	Screw, 10-24 x 9/16"
42	40007	Ring Set (.010" OS)	262	650831	Screw, 1/4-20 x 1/2"
43	20381	Piston Pin Retaining Ring	275	36790	Muffler (Incl. 277)
45	36777	Connecting Rod Ass'y. (Incl. 46)	277	650988	Screw, 1/4-20 x 2-5/16"
46	32610A	Connecting Rod Bolt	285	35000A	Starter Cup
48	27241	Valve Lifter	287	650926	Screw, 8-32 x 21/64"
50	36778	Camshaft (MCR)	290	30705	Fuel Line
52	29914	Oil Pump Ass'y.	292	26460	Fuel Line Clamp
69	35261	* Mounting Flange Gasket	298	28763	Screw, 10-32 x 35/64"
70	34311D	Mounting Flange (Incl. 72 thru 83)	300	34369B	Fuel Tank (Incl. 292 & 301)
72	36083	Oil Drain Plug	301	36246	Fuel Cap
75	27897	Oil Seal	305	35647	Oil Fill Tube
80	30574A	Governor Shaft	306	34265	* "O"-Ring
81	30590A	Washer	307	35499	"O"-Ring
82	30591	Governor Gear Ass'y. (Incl. 81)	309	650562	Screw, 10-32 x 1/2"
83	30588A	Governor Spool	310	35648	Dipstick
86	650488	Screw, 1/4-20 x 1-1/4"	313	34080	Spacer
89	611004	Flywheel Key	370A	36261	Lubrication Decal
90	611112	Flywheel	370B	35167	Control Decal
92	650815	Belleville Washer	370K	36695	Starter Decal
93	650816	Flywheel Nut	380	640026	Carburetor (Incl. 184)
100	34443A	Solid State Ignition	390	590694	Rewind Starter
101	610118	Spark Plug Cover	400	36792	Gasket Set
103	651007	Screw, Torx T-15, 10-24 x 15/16"			(Incl. Items Marked *)
110	34961	Ground Wire	416	36085	Spark Arrestor Kit
119	36787	* Cylinder Head Gasket			(Incl. 417)(Optional)
120	36788	Cylinder Head	417	650760	Screw, 8-32 x 3/8" (Optional)
125	36779	Exhaust Valve (Std.) (Incl. 151)	—	—	RPM High 2900 to 3200
125	36780	Exhaust Valve (1/32" OS)	—	—	RPM Low 2450 to 2750
		(Incl. 151)			
126	36781	Intake Valve (Std.) (Incl. 151)			
126	36782	Intake Valve (1/32" OS) (Incl. 151)			
130	6021A	Screw, 5/16-18 x 1-1/2"			
135	35395	Resistor Spark Plug (RJ19LM)			
150	35991	Valve Spring			
151	31673	Valve Spring Cap			
151A	40017	Intake Valve Seal			
169	36783	* Valve Cover Gasket			
172	36784	Valve Cover			
174	30200	Screw, 10-24 x 9/16"			
178	29752	Nut & Lock Washer, 1/4-28			
182	6201	Screw, 1/4-28 x 7/8"			

(NOTE: This engine could have been built with 590737 starter. Refer to the design of the rope pulley strength ribs for part identification. Individual starter parts do not interchange.)

NOTE: All component dimensions given in U.S. inches
1 inch = 25.4 mm

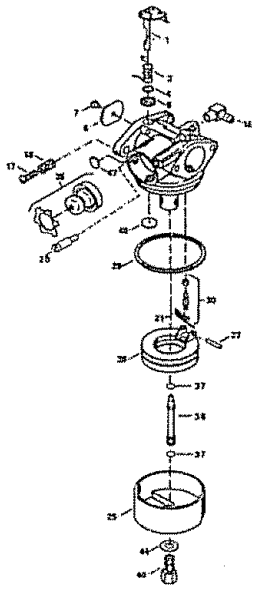

REF PART NO.	NO.	DESCRIPTION
—	640026	Carburetor (Incl. 184 of Engine Parts List)
1	631615	Throttle Shaft & Lever Assembly
2	631767	Throttle Return Spring
4	631184	Dust Seal Washer
5	631183	Dust Seal (Throttle)
6	631036	Throttle Shutter
7	650506	Shutter Screw
16	631775	Fuel Fitting
17	650417	Throttle Crack Screw/Idle Speed Screw
18	630766	Tension Spring
20	640027	Idle Restrictor Screw
25	631867	Float Bowl
27	631024	Float Shaft
28	632019	Float
29	631028	Float Bowl "O" Ring
30	631021	Inlet Needle, Seat, & Clip (Incl. 31)
31	631022	Spring Clip
35	36045	Primer Bulb/Retainer Ring
36	632735	Main Nozzle Tube
37	632547	"O" Ring, Main Nozzle Tube
40	640028	High Speed Bowl Nut
44	27110	Bowl Nut Washer
47	630748	Welch Plug, Idle Mixture Well
48	631027	Welch Plug, Atmospheric Vent

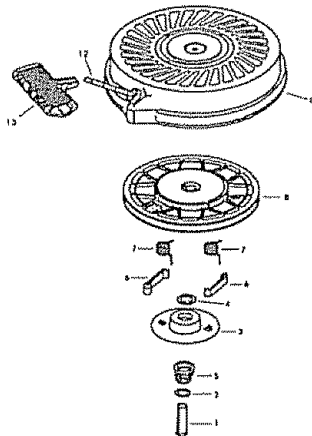

REF PART NO.	NO.	DESCRIPTION
—	590694	Recoil Starter
1	590599A	Spring Pin (Incl. 4)
2	590600	Washer
3	590696	Retainer
4	590601	Washer
5	590697	Brake Spring
6	590698	Starter Dog
7	590699	Dog Spring
8	590700	Pulley & Rewind Spring Ass'y.
11	590695	Starter Housing Ass'y. (40 degree grommet)
12	590535	Starter Rope (98" X 9/64" dia.)
13	590701	Starter Handle

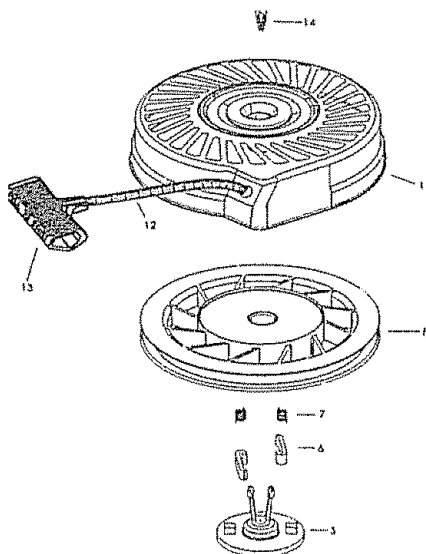

REF PART NO.	NO.	DESCRIPTION
—	590737	Rewind Starter
3	590740	Retainer
6	590616	Starter Dog
7	590617	Dog Spring
8	590618A	Pulley & Rewind Spring Ass'y.
11	590687A	Starter Housing Ass'y. (40 degree grommet)
12	590535	Starter Rope (Length 98" x 9/64" dia.)
13	590701	Starter Handle
14	590741	Locking Tab

NOTE: All component dimensions given in U.S. inches
1 inch = 25.4 mm

TROUBLESHOOTING POINTS

PROBLEM	CAUSE	CORRECTION
Does not start	<ol style="list-style-type: none"> 1. Dirty air filter. 2. Out of fuel. 3. Stale fuel. 4. Water in fuel 5. Spark plug wire is disconnected. 6. Bad spark plug. 7. Loose blade or broken blade adapter. 8. Control bar in released position 9. Control bar defective 	<ol style="list-style-type: none"> 1. Clean/replace air filter 2. Fill fuel tank. 3. Drain tank and refill with fresh clean fuel. 4. Drain fuel tank and carburetor and refill tank with fresh gasoline. 5. Connect wire to plug. 6. Replace spark plug. 7. Tighten blade bolt or replace blade adapter. 8. Depress control bar to handle. 9. Replace control bar.
Loss of power	<ol style="list-style-type: none"> 1. Rear of lawn mower housing/blade dragging in heavy grass. 2. Cutting too much grass. 3. Dirty air filter. 4. Buildup of grass, leaves and trash under mower. 5. Too much oil in engine 6. Walking speed too fast. 	<ol style="list-style-type: none"> 1. Set in "Higher Cut" position. 2. Set in "Higher Cut" position. 3. Clean/replace air filter. 4. Clean underside of mower housing 5. Check oil level. 6. Cut at slower walking speed.
Poor cut - uneven	<ol style="list-style-type: none"> 1. Worn, bent or loose blade 2. Wheel heights uneven. 3. Low engine speed 4. Buildup of grass, leaves, and trash under mower. 	<ol style="list-style-type: none"> 1. Replace blade Tighten blade bolt 2. Set all wheels at same height. 3. Contact an authorized service center/department. 4. Clean underside of mower housing
Excessive vibration	<ol style="list-style-type: none"> 1. Worn, bent or loose blade 2. Bent engine crankshaft. 	<ol style="list-style-type: none"> 1. Replace blade Tighten blade bolt. 2. Contact an authorized service center/department.
Starter rope hard to pull	<ol style="list-style-type: none"> 1. Engine flywheel brake is on when control bar is released. 2. Bent engine crankshaft 3. Blade adapter broken. 4. Blade dragging in grass 	<ol style="list-style-type: none"> 1. Depress control bar to upper handle before pulling starter rope. 2. Contact an authorized service center/department. 3. Replace blade adapter. 4. Move lawn mower to cut grass or to hard surface to start engine.
Grass catcher not filling (if so equipped)	<ol style="list-style-type: none"> 1. Cutting height too low. 2. Lift on blade worn off. 3. Catcher not venting air. 4. Low engine speed. 	<ol style="list-style-type: none"> 1. Raise cutting height. 2. Replace blade. 3. Clean grass catcher 4. Contact an authorized service center/department.
Hard to push	<ol style="list-style-type: none"> 1. Grass is too high or wheel height is too low 2. Rear of lawn mower housing/blade dragging in grass 3. Grass catcher too full 4. Handle height position not right for you. 	<ol style="list-style-type: none"> 1. Raise cutting height. 2. Raise rear of lawn mower housing one (1) setting higher. 3. Empty grass catcher 4. Adjust handle height to suit.

SEARS

OWNER'S MANUAL

**MODEL NO.
917.386132**

IF YOU NEED REPAIR SERVICE OR PARTS:

FOR REPAIR SERVICE, CALL
THIS TOLL FREE NUMBER:

1-800-4-REPAIR
(1-800-473-7247)

FOR REPLACEMENT PARTS
INFORMATION AND
ORDERING, CALL THIS
TOLL FREE NUMBER:

1-800-FON-PART
(1-800-366-7278)

CRAFTSMAN®

4.5 HORSEPOWER 20" REAR DISCHARGE ROTARY LAWN MOWER

Each lawn mower has its own model number. Each engine has its own model number.

The model number for your lawn mower will be found on a decal attached to the rear of the lawn mower housing.

The model number for your engine will be found on the blower housing of the engine.

All parts listed herein may be ordered from any Sears, Roebuck and Co. Service Center/Department and most Retail Stores.

WHEN ORDERING REPAIR PARTS, ALWAYS GIVE THE FOLLOWING INFORMATION:

- PRODUCT - LAWN MOWER
- MODEL NUMBER - 917.386132
- ENGINE - CRAFTSMAN - MODEL NO. 143.964512
- PART NUMBER
- PART DESCRIPTION

Your Sears merchandise has added value when you consider Sears has service units nationwide staffed with Sears trained technicians... professional technicians specifically trained to insure that we meet our pledge to you, we service what we sell.