

Owner's Manual and Installation Instructions

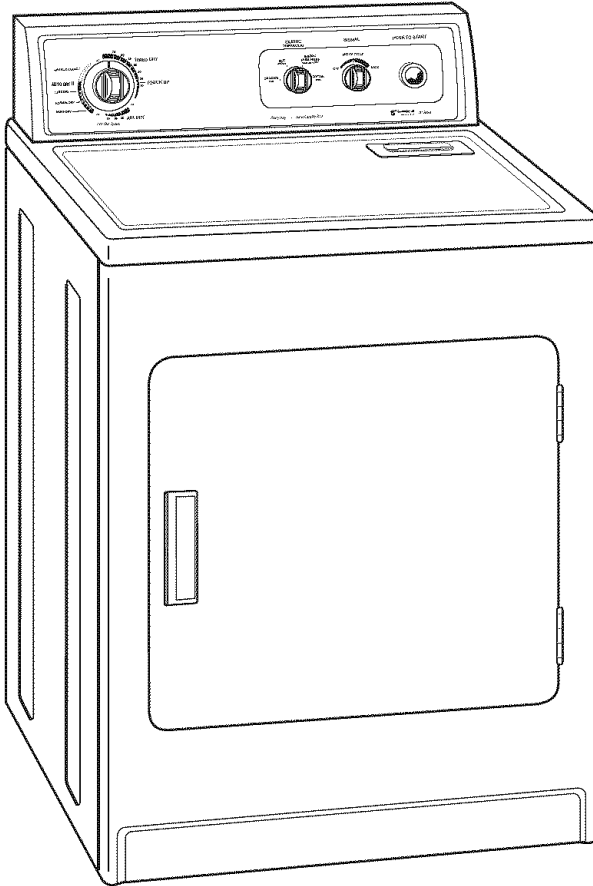

29-Inch Wide GAS DRYERS



IMPORTANT:
Read and follow all safety
and operating instructions
before first use of this product.

Your dryer may look different
from the dryer shown.

WARRANTY/SAFETY

INSTALLATION

OPERATION

LAUNDRY TIPS

MAINTENANCE

TROUBLESHOOTING

SERVICE

Sears, Roebuck and Co., Hoffman Estates, IL 60179 U.S.A.

PART NO. 3405587 Rev. A PRINTED IN U.S.A.

WARNING: For your safety the information in this manual must be followed to minimize the risk of fire or explosion or to prevent property damage, personal injury, or death.

- Do not store or use gasoline or other flammable vapors and liquids in the vicinity of this or any other appliance.

WHAT TO DO IF YOU SMELL GAS

- Do not try to light any appliance.
- Do not touch any electrical switch; do not use any phone in your building.
- Clear the room, building, or area of all occupants.
- Immediately call your gas supplier from a neighbor's phone. Follow the gas supplier's instructions.
- If you cannot reach your gas supplier, call the fire department.

Installation and service must be performed by a qualified installer, service agency, or the gas supplier.

TABLE OF CONTENTS

BEFORE USING YOUR NEW DRYER _____	3
SEARS GAS DRYER WARRANTY _____	4
IMPORTANT SAFETY INSTRUCTIONS _____	5
INSTALLATION INSTRUCTIONS _____	6
OPERATING YOUR DRYER _____	23
LAUNDRY TIPS _____	30
CARING FOR YOUR DRYER _____	32
TROUBLESHOOTING _____	36
SEARS MAINTENANCE AGREEMENT _____	38

BEFORE USING YOUR NEW DRYER

Please read this manual. It will help you install and operate your new Kenmore Dryer in the safest and most economical way.

If you need more information about the care and operation of Kenmore appliances call your nearest Sears store. You will need the complete model and serial numbers when requesting information. Your dryer's model and serial numbers are located on the Model and Serial Number Plate.

Use the space below to record the model number and serial number of your new Kenmore Dryer.

Model No. _____

Serial No. _____

Date of Purchase _____

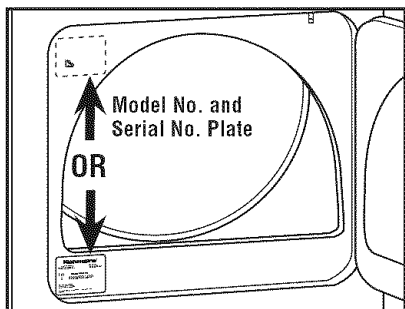

Keep this book and your Sears Salescheck (receipt) in a safe place for future reference.

SEARS GAS DRYER WARRANTY

Full One Year Warranty on Mechanical and Electrical Parts

For one year from the date of purchase, if this dryer is installed and operated according to the instructions in this manual, Sears will repair or replace any of its mechanical or electrical parts if they are defective in material or workmanship.

NOTE: Exhausting your dryer with a plastic vent may void this warranty. Pages 17-21 of this manual describe the complete exhaust requirements for this dryer.

Warranty Restriction

If the dryer is subjected to other than private family use, all warranty coverage is effective for only 90 days.

Warranty Service

Warranty service is available by contacting your nearest Sears Service Center in the United States.

This warranty applies only while this dryer is in use in the United States.

This warranty gives you specific legal rights, and you may also have other rights which vary from state to state.

**Sears, Roebuck and Co., Dept. 817WA,
Hoffman Estates, IL 60179.**

Your safety and the safety of others is very important.

We have provided many important safety messages in this manual and on your appliance. Always read and obey all safety messages.



This is the safety alert symbol. This symbol alerts you to hazards that can kill or hurt you and others. All safety messages will be preceded by the safety alert symbol and the word "DANGER" or "WARNING." These words mean:

! DANGER

You will be killed or seriously injured if you don't follow instructions.

! WARNING

You can be killed or seriously injured if you don't follow instructions.

All safety messages will identify the hazard, tell you how to reduce the chance of injury, and tell you what can happen if the instructions are not followed.

IMPORTANT SAFETY INSTRUCTIONS

YOUR SAFETY IS IMPORTANT TO US.

WARNING: To reduce the risk of fire, electric shock, or injury to persons when using your dryer, follow basic precautions, including the following:

- Read all instructions before using the dryer.
- Do not dry articles that have been previously cleaned in, washed in, soaked in, or spotted with gasoline, dry-cleaning solvents, or other flammable or explosive substances as they give off vapors that could ignite or explode.
- Do not allow children to play on or in the dryer. Close supervision of children is necessary when the dryer is used near children.
- Before the dryer is removed from service or discarded, remove the door.
- Do not reach into the dryer if the drum is moving.
- Do not install or store this dryer where it can be exposed to water and/or weather.
- Do not tamper with controls.
- Do not repair or replace any part of the dryer or attempt any servicing unless specifically recommended in the Owner's Manual or in published user-repair instructions that you understand and have the skills to carry out.
- Do not use fabric softeners or products to eliminate static unless recommended by the manufacturer of the fabric softener or product.
- Do not use heat to dry articles containing foam rubber or similarly textured rubber-like materials.
- Clean lint screen before or after each load.
- Keep area around the exhaust opening and adjacent surrounding areas free from the accumulation of lint, dust, and dirt.
- The interior of the machine and exhaust vent should be cleaned periodically by qualified service personnel.

SAVE THESE INSTRUCTIONS

IMPORTANT: The gas installation must conform with local codes, or in the absence of local codes, with the National Fuel Gas Code, ANSI Z223.1.

The dryer must be electrically grounded in accordance with local codes, or in the absence of local codes, with the National Electrical Code, ANSI/NFPA 70.

INSTALLATION INSTRUCTIONS

INSTALLATION OVERVIEW

For a complete list of tools and parts needed, see pages 6-8.

A. SELECT LOCATION FOR YOUR DRYER (pgs. 9-12)

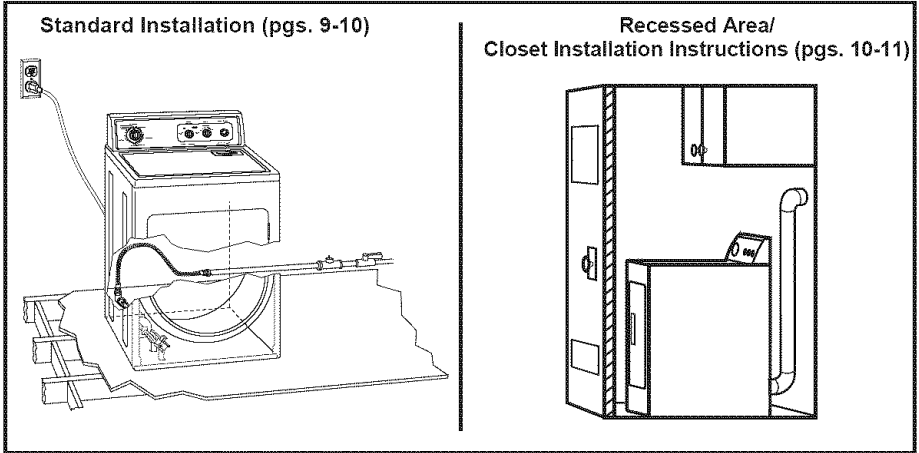

B. INSTALL LEVELING LEGS (p. 13)

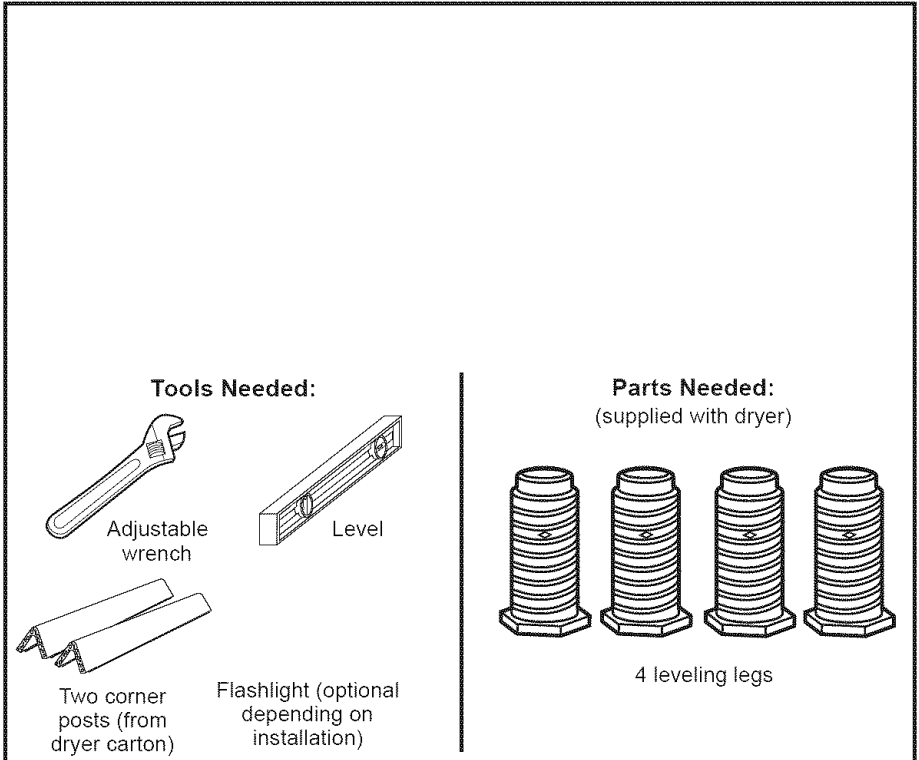

C. INSTALL GAS LINE (pgs. 14-16)

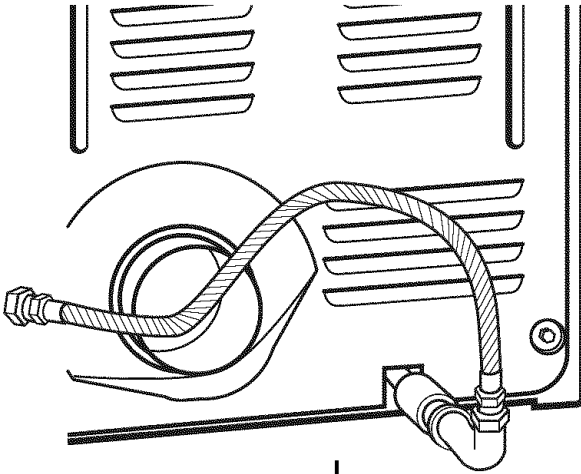

Tools Needed:

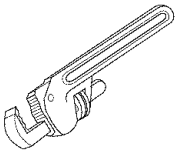

8-inch
or 10-inch
pipe wrench



Pipe-joint
compound
resistant to
L.P. gas

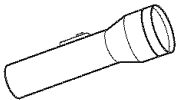

Flashlight (optional
depending on installation)

Parts Needed:

Do not use pipe
joint compound

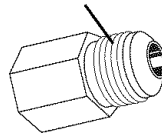

$\frac{3}{8}$ -inch male pipe flare
(optional depending
on installation)

Use pipe joint
compound

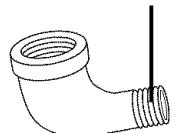

$\frac{1}{2}$ -inch to
 $\frac{3}{8}$ -inch pipe
reducer

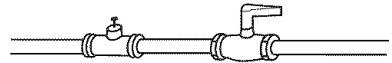

Rigid gas supply line approved for
natural gas use (**NOTE:** additional
fittings may be required)

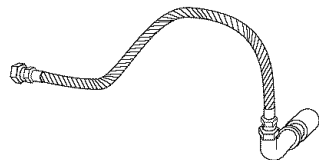

$\frac{3}{8}$ -inch diameter, flexible stainless
steel 4-foot or 6-foot gas line, including
gas supply pipe and dryer connectors

D. CONNECT EXHAUST (pgs. 17-21)

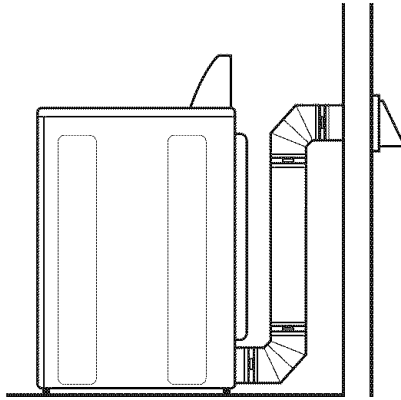

Tools Needed:

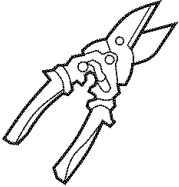

Tin snips

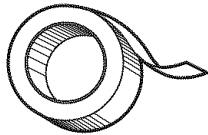

Duct tape

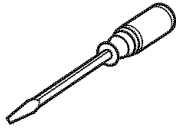

Flat-bladed
screwdriver

Flashlight
(optional depending
on installation)

Parts Needed:

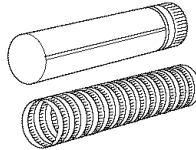

4-inch rigid or
flexible heavy
metal vent

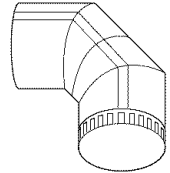

4-inch metal elbow(s)
(optional depending
on installation)

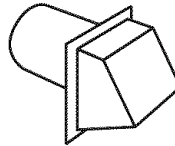

4-inch outlet
exhaust hood

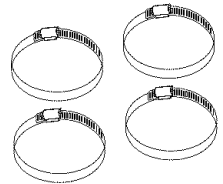

(4) 4-inch
diameter clamps

A. SELECT LOCATION FOR YOUR DRYER

Selecting the proper location for your dryer makes installation easy and gives you the best drying performance.

STANDARD INSTALLATION

Check location where dryer will be installed. Proper installation is your responsibility. Make sure you have everything necessary for correct installation (see illustration below).

The dryer must not be installed where it can be exposed to water and/or weather.

- Proper operation of dryer cycles requires temperatures above 45°F (at lower temperatures, the dryer may not shut off at the end of automatic cycles and drying times will be extended).
- Use at least the minimum installation spacings described on page 11. This will ensure you have an adequate clearance for service and proper operation including flow of combustion and ventilation air, and that you have a sufficient distance from combustible construction.

⚠ WARNING

Explosion Hazard

Keep flammable materials and vapors, such as gasoline, away from dryer.
Place dryer at least 18 inches above the floor for a garage installation.
Failure to follow these instructions can result in death, explosion, or fire.

INSTALLATION

- Be sure your location allows for a proper exhaust installation. A gas dryer must be exhausted to the outdoors. See pages 17-21 for complete exhaust requirements.
- Check code requirements. Some codes limit or do not permit installation of clothes dryers in garages, closets, mobile homes, or sleeping quarters. Contact your local building inspector.

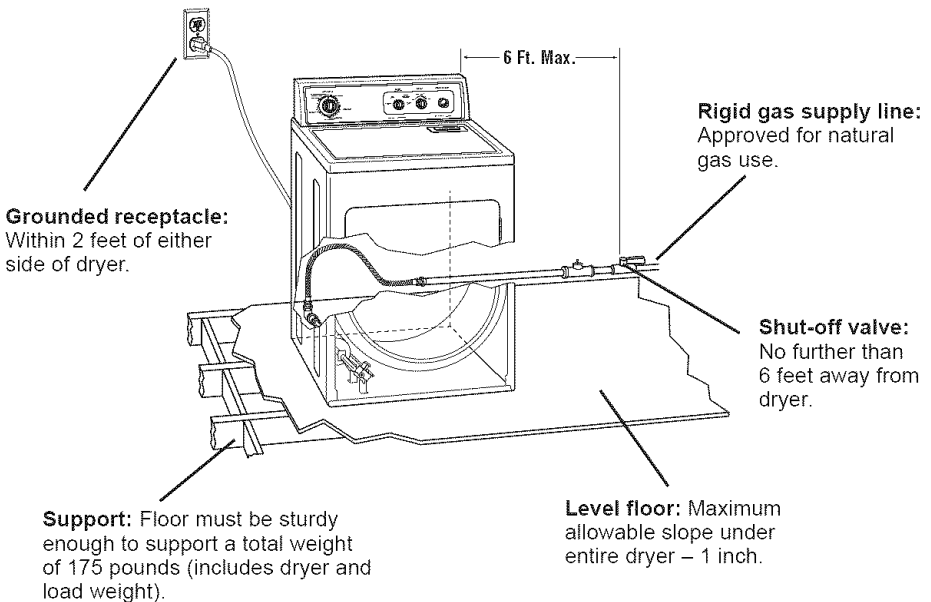

DRYER DIMENSIONS

Most installations will require at least 5-inch clearance behind the dryer for the dryer vent.

Location must be large enough to fully open dryer door.

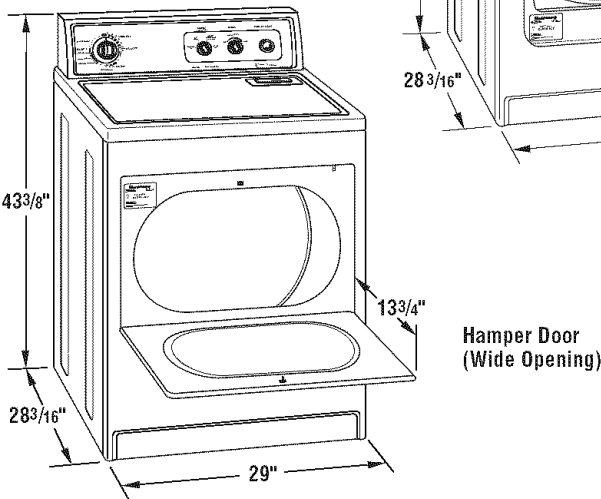
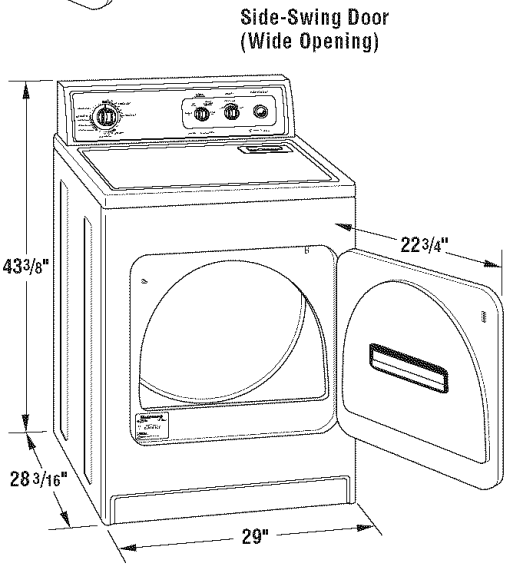
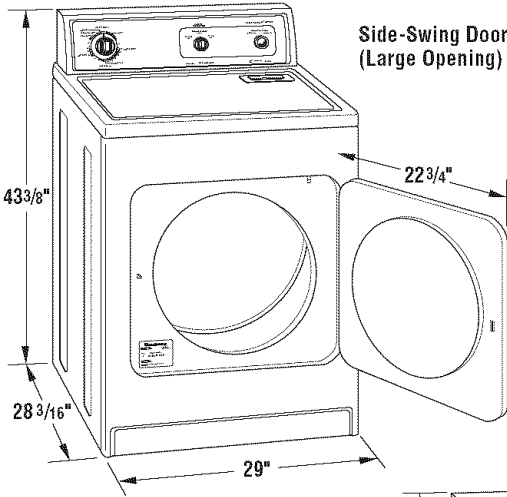

RECESSED AREA/CLOSET INSTALLATION INSTRUCTIONS

Check governing codes and ordinances.

This dryer may be installed in a recessed area or closet.

The dryer must not be installed where it will be exposed to water and/or weather.

- Proper operation of dryer cycles requires temperatures above 45°F (at lower temperatures, the dryer may not shut off at the end of automatic cycles and drying times will be extended).
- Use at least the minimum installation spacings described below. This will ensure you have an adequate clearance

for service and proper operation including flow of combustion and ventilation air, and that you have a sufficient distance from combustible construction.

- Be sure your location allows for a proper exhaust installation. A gas dryer must be exhausted to the outdoors. See pages 17-21 for complete exhaust requirements.
- Check code requirements. Some codes limit or do not permit installation of clothes dryers in garages, closets, mobile homes, or sleeping quarters. Contact your local building inspector.

NOTE: No fuel-burning appliances may be installed in the same closet as a dryer.

MINIMUM INSTALLATION SPACING

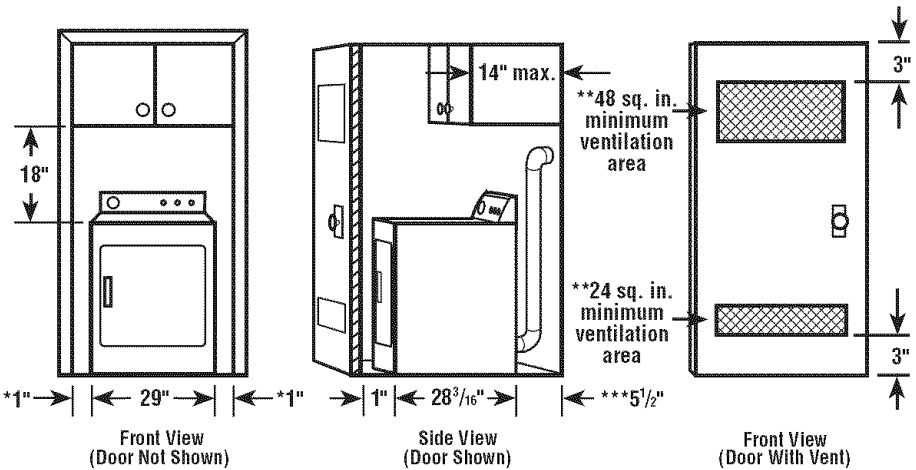

* Additional clearances for wall, door and floor moldings may be required. 0" clearance is acceptable but not recommended.

** Opening is minimum for closet door. Louvered door with equivalent air openings is acceptable.

*** Additional space is needed when external exhaust elbow is used. Can be 0" clearance when house exhausting is lined up directly with dryer exhaust.

- In the above illustration, the installation spacing is in inches and is the minimum allowable.
- Additional spacing should be considered for ease of installation and servicing.
- If closet door is installed, the minimum air openings in top and bottom are

required. Louvered doors with equivalent air openings in top and bottom are acceptable.

- All installations must be exhausted outside. Use at least the minimum dimensions indicated.

MOBILE HOME EXHAUST REQUIREMENTS

- The dryer must not be installed where it can be exposed to water and/or weather. Proper operation of dryer cycles requires temperatures above 45°F (at lower temperatures, the dryer may not shut off at the end of automatic cycles and drying times will be extended).
- Use at least the minimum installation spacings described on page 11. This will ensure you have an adequate clearance for service and proper operation including flow of combustion and ventilation air, and that you have a sufficient distance from combustible construction.
- Special provisions must be made for the introduction of outside air into the dryer when installed in a mobile home. The area of any opening for the introduction of outside air (such as a nearby window) should be at least twice as large as the dryer exhaust opening.

This dryer is suitable for mobile home installations. The installation must conform to the Manufactured Home Construction and Safety Standard, Title 24 CFR, Part 3280 (formerly the Federal Standard for Mobile Homes Construction and Safety, Title 24, HUD Part 280).

- Dryer exhaust vent must not be connected or secured with screws or other devices which extend into the interior of the vent.
- A gas dryer must be exhausted outdoors. The exhaust vent must be securely fastened to a noncombustible portion of the mobile home structure and must not terminate beneath the mobile home.

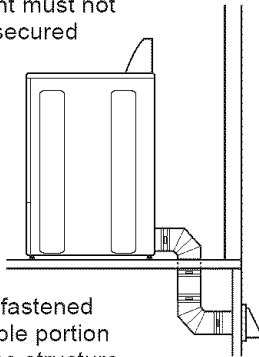

For mobile home use, gas dryers must be securely fastened to the floor. Order Mobile Home Installation Kit 346764 from your Sears store or Sears Service Center. Kit includes the necessary fastening hardware and detailed installation instructions. Exhaust system hardware is also available through your Sears store or Sears Service Center.

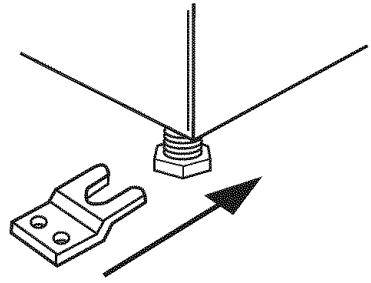

B. INSTALL LEVELING LEGS

Leveling your dryer correctly will reduce operating noise and provide improved drying performance.

STEP 1. Take two of the cardboard corners from the carton. Place them on the floor in back of the dryer.

STEP 2. Firmly grasp the body of the dryer (not the top or console panel). Gently lay dryer on the cardboard corners.

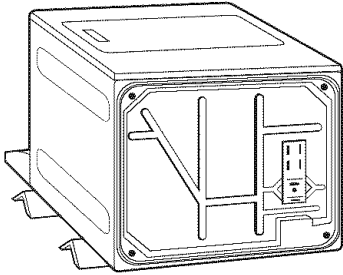

STEP 3. With one of the legs in hand, check the ridges for a diamond marking.

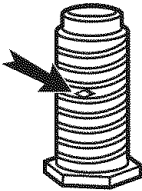

STEP 4. Start to screw the legs into the holes by hand. Use a wrench to finish turning the legs until diamond marking is no longer visible. This is when we recommend you start checking the dryer for levelness. Further adjustment may be necessary.

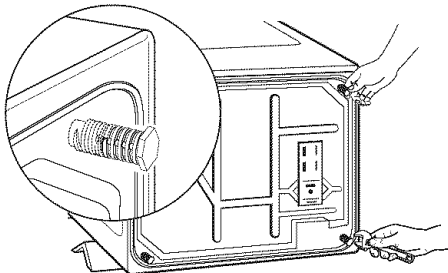

STEP 5. Stand the dryer up and move it close to its final location. Leave enough room to connect the exhaust vent.

STEP 6. Check levelness of dryer by placing a level on top of the dryer, first side-to-side; then front-to-back.

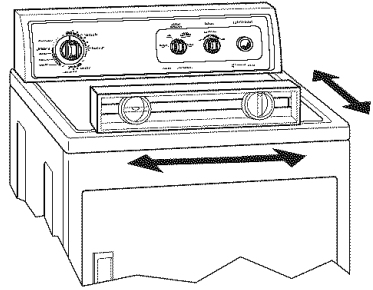

STEP 7. If dryer is not level, prop the dryer up using two stacked cardboard corner posts. Use a wrench to adjust the legs up or down.

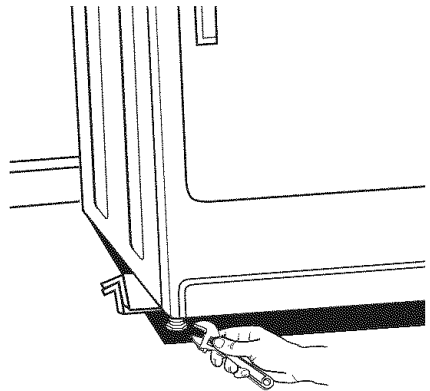

NOTE: It may be necessary to level the dryer again after it is moved into its final position.

C. INSTALL GAS LINE

for your **Benefit**

The proper gas connection ensures a safe installation that meets local code requirements.

GAS REQUIREMENTS

! WARNING



Explosion Hazard

Use a new AGA approved gas supply line.

Connect dryer to a regulated gas supply with a shut-off valve.

L.P. gas supply pressure must not exceed 13" water column.

Securely tighten all gas connections.

Failure to follow these instructions can result in death, explosion, or fire.

It is your responsibility to contact a qualified gas line installer to ensure you have natural gas.

- The design of this dryer has been certified by the American Gas Association for use at altitudes up to 10,000 feet above sea level at the B.T.U. rating indicated on the model/serial number plate. Burner input adjustments are not required when the dryer is operated up to this level.
- When installed above 10,000 feet, a four percent (4%) reduction of the burner B.T.U. rating shown on the model/serial number plate is required for each 1,000 foot increase in elevation. For assistance when converting to other gas types and/or installing above 10,000 feet elevation contact your local service company.

- Make certain your dryer has the correct burner for the type of gas in your home. Burner information is located on the rating plate in the door well of your dryer. If this information does not agree with the type of gas available, contact your local Sears store or Sears Service Center. Any change to the burner must be made by a qualified installer.
- Provide a rigid gas supply line of 1/2-inch pipe to your dryer.
- If you are using natural gas, do not use copper tubing.
- If your dryer has been converted to use L.P. gas, 3/8-inch L.P.-compatible copper tubing may be used. If the total length of the supply line is more than 20 feet, use larger pipe. Pipe joint compounds that resist the action of L.P. gas **MUST** be used. Do not use Teflon tape.

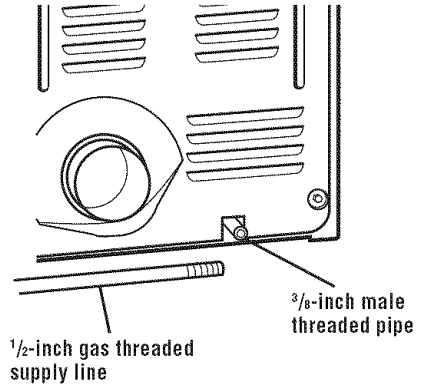

- If local codes permit, use flexible stainless steel tubing (Design Certified by the American Gas Association) to connect your dryer to the gas supply line. To prevent kinking, you may need an elbow and connector between the stainless steel tubing and the dryer gas pipe. The gas pipe that comes out through the rear of your dryer has a $\frac{3}{8}$ -inch male pipe thread.

- A combination of pipe fittings must be used to connect the dryer to the existing gas line.

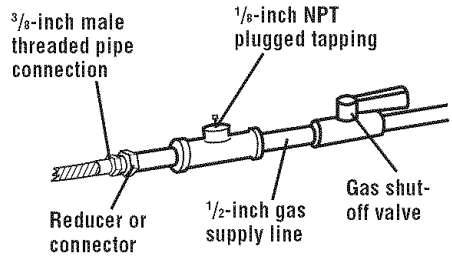

INSTALLATION

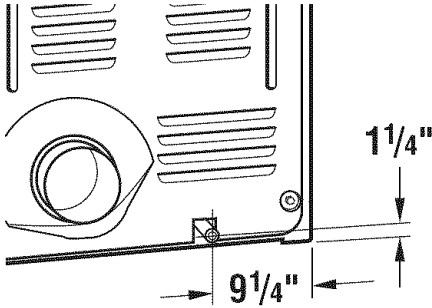

- The gas supply must have a shut-off valve. The valve should be in the same room as the dryer, within six feet. The location should be easy to reach for opening and closing the valve.
- A $\frac{1}{8}$ -inch NPT plugged tapping, accessible for test gauge connection, must be installed immediately upstream of the gas supply connection to the dryer.
- To ensure proper combustion and ventilation, the dryer installation should adhere to the minimum recommended clearances. See page 11.
- For mobile home installation, see page 12 for more instructions.
- The dryer must be disconnected from the gas supply piping system during any pressure testing of that system at test pressures in excess of $\frac{1}{2}$ psig.

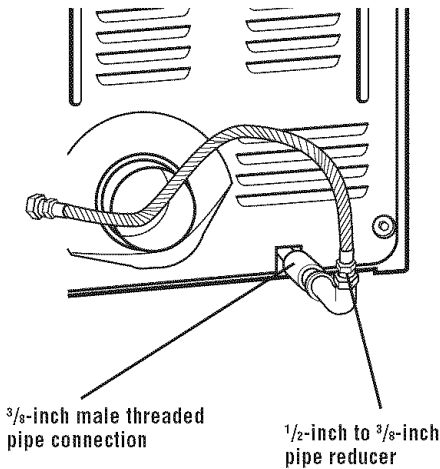

CONNECT DRYER TO GAS LINE

⚠ WARNING

Explosion Hazard

Use a new flexible gas supply line.
Failure to do so can result in death, explosion, or fire.

STEP 1. Remove the red cap from the gas pipe. Move the dryer to its final position.

STEP 2. Connect gas supply to dryer. Use a wrench to tighten. For gas connections you must use pipe joint compound resistant to the action of L.P. gas. **Apply pipe joint compound to the non-flared male threads only.** If flexible metal tubing is used be sure there are no kinks.

Do not use pipe joint compound

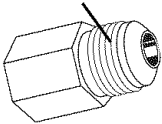

Use pipe joint compound

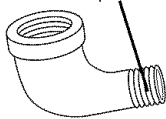

STEP 3. Open the shut-off valve in the supply line. The valve is open when the handle is parallel to the gas pipe.

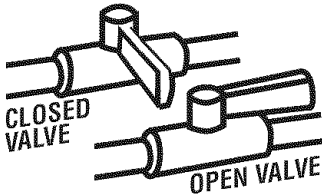

STEP 4. Test all the connections by brushing on a soapy water solution (liquid detergent also works well). Bubbles will show a leak. Correct any leak found. Never test for gas leaks with a flame.

ELECTRICAL REQUIREMENTS

It is your responsibility:

- To contact a qualified electrical installer.
- To assure that the electrical installation is adequate and in conformance with the National Electrical Code, ANSI/NFPA 70 – latest edition and all local codes and ordinances.

Copies of the code standards listed above may be obtained from:

National Fire Protection Association
Batterymarch Park
Quincy, Massachusetts 02269

The proper electrical connection ensures a safe installation that meets local code requirements.

⚠ WARNING



Electrical Shock Hazard
Plug into a grounded 3-prong outlet.

Do not remove ground prong.

Do not use an adapter.

Do not use an extension cord.

Failure to follow these instructions can result in death, fire, or electrical shock.

- A 120-volt, 60-Hz., AC-only, 15- or 20-ampere fused electrical supply is required.
- A time-delay fuse or circuit breaker is recommended. Be sure fuse or circuit breaker matches the rating of your line.
- Use a separate circuit serving only your dryer.
- Do not use an extension cord.

GROUNDING INSTRUCTIONS

This appliance must be grounded. In the event of malfunction or breakdown, grounding will reduce the risk of electric shock by providing a path of least resistance for electric current. This appliance is equipped with a cord having an equipment-grounding conductor and a grounding plug. The plug must be plugged into an appropriate outlet that is properly installed and grounded in accordance with all local codes and ordinances.

WARNING: Improper connection of the equipment-grounding conductor can result in a risk of electric shock. Check with a qualified electrician or serviceman if you are in doubt as to whether the appliance is properly grounded.

Do not modify the plug provided with the appliance – if it will not fit the outlet, have a proper outlet installed by a qualified electrician.

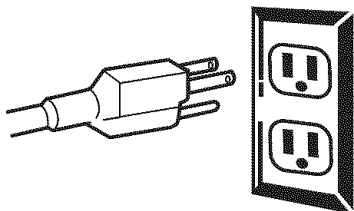

D. CONNECT EXHAUST

A properly exhausted dryer will give you the shortest drying time, lower your utility bills, and extend the life of the dryer.

⚠ WARNING



Fire Hazard

**Use a heavy metal vent.
Do not use a plastic vent.
Do not use a metal foil vent.
Failure to follow these instructions
can result in death or fire.**

WARNING: To reduce the risk of fire, this dryer must be exhausted outdoors.

- Use a heavy metal vent.
- Do not use a plastic vent.
- Do not use a metal foil vent.
- Do not exhaust dryer into a chimney, a wall, a ceiling, or a concealed space of a building.
- The diameter of the heavy metal vent must be 4 inches.
- Do not use an exhaust hood with a magnetic latch.
- If using an existing exhaust system, disconnect vent from the dryer and clean one section at a time until you reach the exhaust hood. To clean out lint, you can use the hose attachment on your vacuum, or use a pole or wire with a feather duster or rag attached.

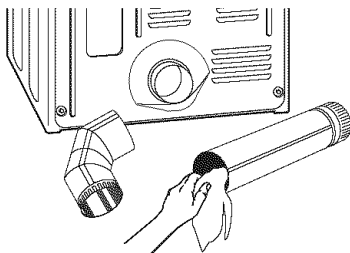

- Make sure exhaust hood is not plugged with lint. Follow the instructions in this section to reinstall your vent system.

ROUTE THE VENT

Typical installations exhaust from the rear of the dryer.

Avoid pushing the dryer tightly against a wall. This can crush or kink the vent. Use the straightest path you can, where possible. Avoid 90° turns.

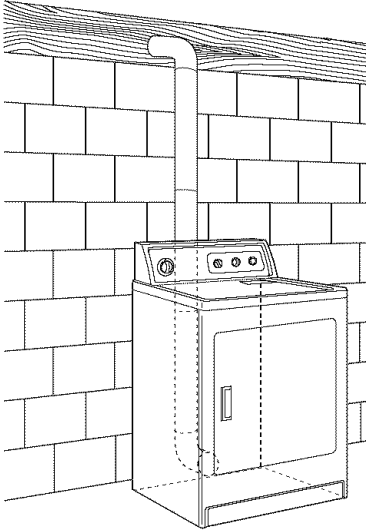

Rear exhaust installations for standard offset connections – (see pgs. 19-20)

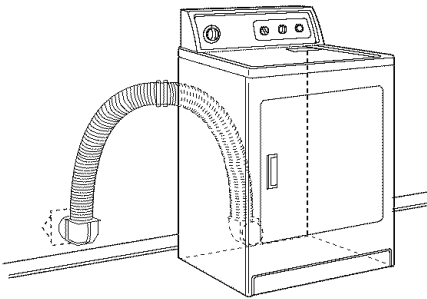

Rear exhaust installations for offset connections with close clearances – (see p. 21)

DETERMINE VENT LENGTH

Maximum Exhaust Lengths:

- The maximum length of the rear exhaust system depends on the type of vent, the number of elbows, and the type of exhaust hood. Refer to the chart below.

NOTE: If a combination of rigid metal vent and flexible metal vent is used, use instructions for flexible metal vent.

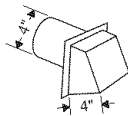
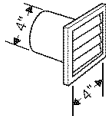
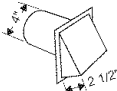
4-INCH EXHAUST HOODS	
 	
Number of 90° Turns	Maximum length of 4-inch diameter rigid heavy metal vent
0	64 ft.
1	54 ft.
2	44 ft.
3	35 ft.
4	27 ft.
Number of 90° Turns	Maximum length of 4-inch diameter flexible heavy metal vent
0	36 ft.
1	31 ft.
2	27 ft.
3	25 ft.
4	23 ft.
2 1/2-INCH EXHAUST HOODS*	
	
Number of 90° Turns	Maximum length of 4-inch diameter rigid heavy metal vent
0	58 ft.
1	48 ft.
2	38 ft.
3	29 ft.
4	21 ft.
Number of 90° Turns	Maximum length of 4-inch diameter flexible heavy metal vent
0	28 ft.
1	23 ft.
2	19 ft.
3	17 ft.
4	15 ft.

*Use a 4-inch exhaust hood if possible.

STANDARD OFFSET CONNECTIONS

Using 4-inch rigid heavy metal vent:

NOTE: Do not secure exhaust vent joints with screws. Screws can catch lint and slow the drying process. Instead, use clamps to secure exhaust vent joints.

STEP 1. Install a 4-inch metal elbow on the hood and on the dryer's exhaust outlet.

STEP 2. Measure the length of 4-inch rigid heavy metal vent needed to connect the two elbows.

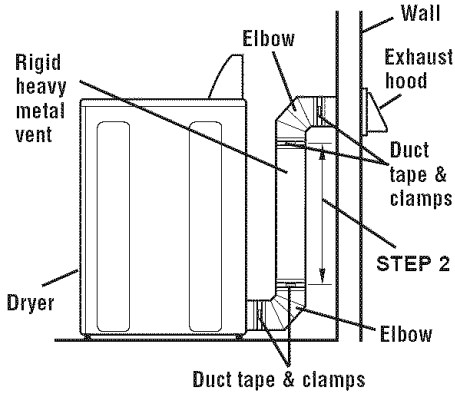

STEP 3. Place a clamp on each end of vent elbow and connect elbow to your dryer's exhaust outlet. Tape the joint with duct tape. Tighten clamp.

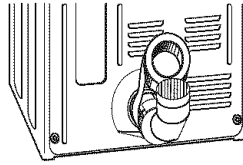

Tape

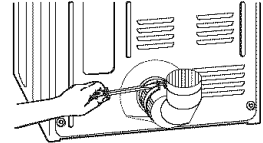

Clamp

STEP 4. Connect vent to elbow. Tape the joint with duct tape. Tighten clamp.

STEP 5. Install one end of elbow on vent, the other end to the exhaust hood. Tape joints and tighten clamps.

Finish installation. See "REVIEW INSTALLATION" on page 22.

The vent usually comes in 2-foot lengths. Use tin snips to cut the vent 3 inches longer than your measurement in order to make a connection.

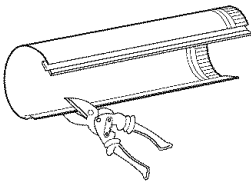

Using 4-inch flexible heavy metal vent:

NOTE: Do not secure exhaust vent joints with screws. Screws can catch lint and slow the drying process. Instead, use clamps to secure exhaust vent joints.

STEP 1. Install a 4-inch metal elbow on the exhaust hood and, if necessary, on the dryer's exhaust outlet.

STEP 2. Measure the length of 4-inch flexible heavy metal vent needed from the dryer to the hood.

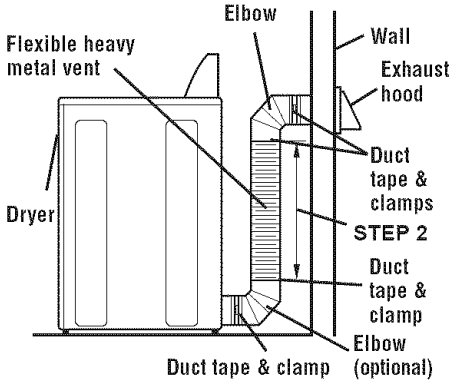

STEP 3. Add 10 inches to the measurement for each bend in the vent.

STEP 4. Add 3 more inches to the measurement for connection over the dryer's exhaust outlet and hood.

STEP 5. Place a clamp on each end of vent elbow. Install one end of elbow on vent, the other end to the exhaust hood. Tape joints and tighten clamps.

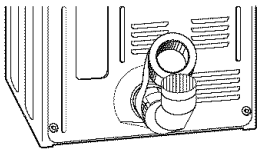

Tape

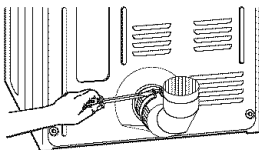

Clamp

STEP 6. Stretch the vent only as needed by pulling out from the center in each direction. Do not stretch vent sections over 6 feet. If distance is more than 6 feet, use 2 or more sections of rigid metal vent with flexible metal vent attached at ends.

STEP 7. Connect the vent directly to the dryer outlet or to a separate elbow. Tape the joints with duct tape. Secure with clamps.

STEP 8. To fit the vent over the duct on the hood it may be necessary to make two 1/2-inch cuts in the end of the vent to allow it to expand.

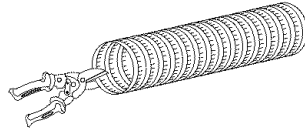

Finish installation. See "REVIEW INSTALLATION" on page 22.

OFFSET CONNECTIONS WITH CLOSE CLEARANCES

When your exhaust vent is in a close clearance behind the dryer, or if you are installing your dryer in a recessed area or closet, you will find it helpful to install the exhaust vent over-the-top* of the dryer. A kit is available from your local Sears store or Sears Service Center.

*Parts may be covered by one or more U.S. Patents.

NOTE: Vent systems come in many varieties. Select the type that best fits your installation. Three of the most common types of installations are illustrated here.

LOOP SYSTEM

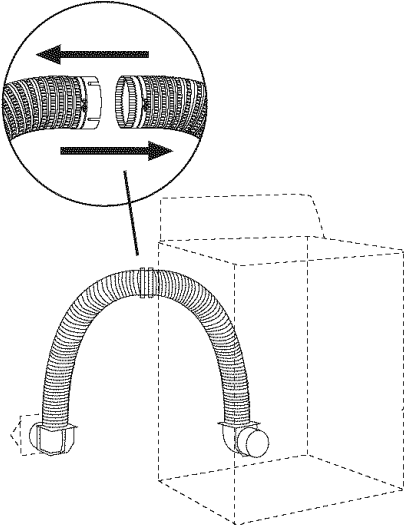

Vent system installed over-the-top with standard elbows

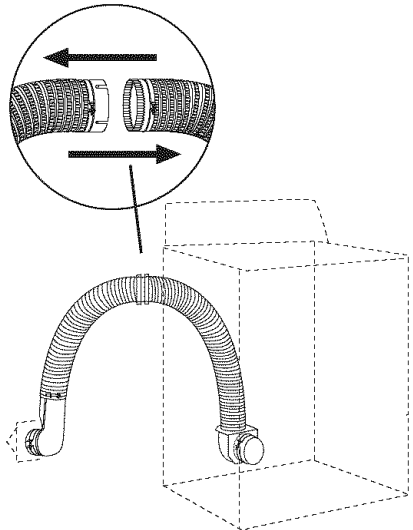

Vent system installed over-the-top with one offset and one standard elbow

PERISCOPE SYSTEM

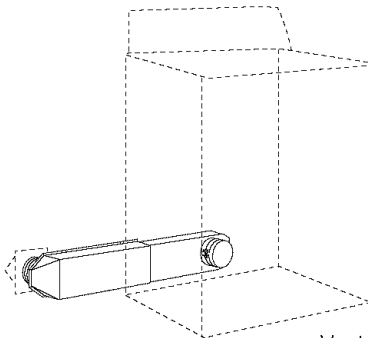

Vent system with one periscope (2-inch clearance)

REVIEW INSTALLATION

Take a few minutes to complete this checklist. It will help assure you that you have a proper installation and increase your satisfaction with your Kenmore dryer.

- Check that all parts you removed from the parts packages are now installed.
 - Ensure that dryer is positioned in its final location. Make sure vent is not crushed or kinked.
 - Ensure that dryer is level by placing a level on top of the dryer. Check side-to-side first, then check front-to-back. If dryer is not level, adjust the legs up or down.
 - Check to make sure you have all the tools you started with.
-

FINAL STEPS

- Plug the power supply cord into the grounded outlet or power supply.
- Turn power supply on.
- Wipe the interior of the drum thoroughly with a damp cloth to remove any dust.
- Remove the blue protective film on the console and any tape remaining on dryer.
- Take a few minutes and read the Operating Instructions (pgs. 23-29) to fully understand your new dryer.
- To remove air from the gas line, set the dryer on a full heat cycle (not the AIR DRY Cycle) for 20 minutes. After five minutes, open dryer door. The burner should have ignited during these five minutes. If you do not feel heat, turn the dryer off and WAIT 5 MINUTES. During these 5 minutes check to be sure dryer gas supply valve is open. Repeat steps above. If the burner still does not ignite, see "TROUBLESHOOTING" on pages 36-37.

OPERATING YOUR DRYER

STARTING YOUR DRYER

WARNING

Explosion Hazard

Keep flammable materials and vapors, such as gasoline, away from dryer.

Do not dry anything that has ever had anything flammable on it (even after washing).

Failure to follow these instructions can result in death, explosion, or fire.

WARNING



Fire Hazard

No washer can completely remove oil.

Do not dry anything that has ever had any type of oil on it (including cooking oils).

Items containing foam, rubber, or plastic must be dried on a clothesline or by using an air cycle.

Failure to follow these instructions can result in death or fire.

To get the best drying results, you must operate your dryer properly. This section gives you this important information.

NOTE: The drawings in this section show the basic features of all models covered by this manual. Refer to the supplied "Feature Sheet" for your dryer's particular features.

STEP 1. Check lint screen. Clean if needed.

STEP 2. Put laundry into dryer and shut door.

STEP 3. Set Cycle Selector Control (Timer) **A** (see pgs. 24 and 26).

STEP 4. Set FABRIC/TEMPERATURE Control **B**, if available (see p. 25). Check clothes label for manufacturer's recommendations.

STEP 5. Press PUSH TO START Button **C**. Be sure door is closed.

STOPPING/RESTARTING YOUR DRYER

- To stop the dryer at any time, open dryer door.
- To restart, press PUSH TO START Button. Be sure door is closed.
- If you wish to end your drying cycle, turn Cycle Selector Control (Timer) to OFF.



CYCLE DESCRIPTION

The **AUTO DRY** Cycle saves you time by providing the best drying results in the shortest time. This can help you save money on utility bills and reduce the risk of fabric damage.

AUTO DRY CYCLE

Use AUTO DRY for most loads. Drying time varies according to type of fabric, size of load, and dryness setting.

Using Automatic Drying Cycles

- Set the Cycle Selector Control (Timer) to **NORMAL DRY(*)** which is good for most fabrics.
- At the end of the cycle, feel the dried clothes. If they are damp, select **MORE DRY** the next time you do a similar load. If they are overdried, select **LESS DRY** the next time you do a similar load.
- If your dryer has an end-of-cycle signal, it will sound (if selected) once the cycle is completed. Select models feature a non-adjustable end-of-cycle signal.

On Dryers with AUTO DRY II

- Dryness is determined by an electronic sensor that “feels” the amount of moisture in clothes as they pass over it. When the dryness selected is reached, the dryer goes into a 10-minute (approx.) COOL DOWN period.
- If you do not unload the dryer, it goes into **WRINKLE GUARD** automatically, if available. For an explanation of **WRINKLE GUARD**, see page 28.

On Dryers with AUTO DRY I

- Dryness is determined by thermostats that react to the amount of moisture in the air exhausted from the dryer. Moist air indicates clothes are still damp. Dry air indicates that moisture has been removed.

NOTE: Dryers that do not have a **FABRIC/TEMPERATURE** Control, give you a choice of settings for high heat (**PERMANENT PRESS/NORMAL**) or low heat (**KNIT/DELICATE**).

TIMED DRY CYCLE

Use this cycle to get 60, 70, or 80 minutes (depending on model) of heated drying time.

- The heating cycle is followed by a 10-minute (approx.) **COOL DOWN** period.
- If your dryer has an end-of-cycle signal, it will sound (if selected) once the cycle is completed. Select models feature a non-adjustable end-of-cycle signal.

TOUCH UP CYCLE

Use this cycle to smooth synthetic and permanent press clothes that are clean but wrinkled from being crowded in a closet or suitcase.

- This setting provides about 15 minutes of heated drying time followed by a 10-minute (approx.) **COOL DOWN** period.
- If your dryer has an end-of-cycle signal, it will sound (if selected) once the cycle is completed. Select models feature a non-adjustable end-of-cycle signal.
- Remove clothes immediately when tumbling stops.

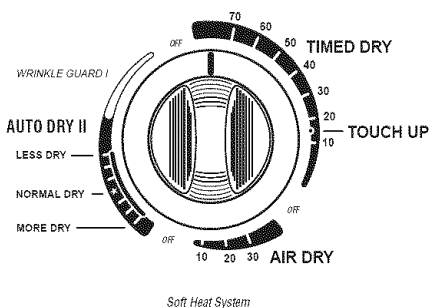

FABRIC/TEMPERATURE CONTROL

Proper use of this control helps ensure that fabrics are dried at the right temperature for maximum life.

Use this control to select the drying temperature that matches the fabrics in your load.

- Select **LOW** for delicate fabrics. Select **HIGH** for durable fabrics such as sturdy work clothes or bath towels.
- The **FABRIC/TEMPERATURE Control** will not work when the **Cycle Selector Control (Timer)** is in the **AIR DRY Cycle**.

The following table lists suggested dryer settings and drying times for various loads. This is only a guide. Settings may require adjustment depending on the requirements of your load.

Type of Load	AUTO DRY Setting	Drying Temp	TIMED DRY Setting**
COTTONS AND LINENS			
Extra Heavy – Bedspreads, mattress pads, quilts	MORE DRY	HIGH	70-80 min.
Heavyweight – Towels, jeans, corduroys, work clothes	MORE DRY	HIGH	50-60 min.
Medium Weight – Sheets, cotton underwear, diapers	NORMAL DRY	MEDIUM/HIGH or MEDIUM*	40-50 min.
Lightweight – Batistes, organdies, lingerie	NORMAL DRY	LOW	30-40 min.
PERMANENT PRESS, SYNTHETICS AND BLENDS			
Heavyweight – Work clothes, jackets, raincoats	NORMAL DRY	HIGH	40-50 min.
Medium Weight – Shirts, play clothes, sheets, slacks	NORMAL DRY	MEDIUM/HIGH or MEDIUM*	30-40 min.
Lightweight – Lingerie, blouses, dresses	LESS DRY	MEDIUM or LOW*	20-30 min.
KNITS			
Heavyweight – Cottons, rayons, blends, T-shirts, slacks, shirts	NORMAL DRY	HIGH	40-50 min.
Medium Weight – Synthetics (polyester, acrylic, etc.), dress slacks, skirts, sweaters	NORMAL DRY	MEDIUM/HIGH or MEDIUM*	30-40 min.
Lightweight – Synthetics (polyester, acrylic, etc.) and blends, lingerie, blouses, dresses	LESS DRY	LOW	20-30 min.

*Use the lowest temperature setting available on your dryer.

**Reset time, as needed, to allow items to dry completely.

USING AIR DRY

Using this cycle gives you all the benefits of hang drying with a shorter drying time.

Use the AIR DRY Cycle to get up to 20 or 30 minutes (depending on model) of drying time in room temperature air. Use this setting for items that will not tolerate heat such as plastics and foam rubber. Also use for airing and fluffing items such as pillows.

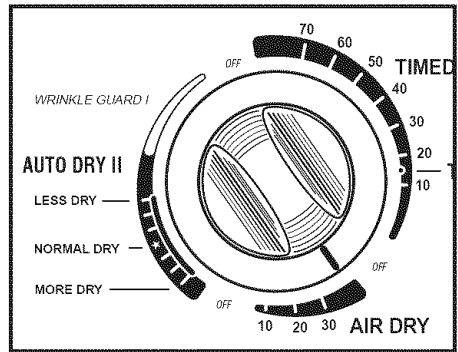

Refer to the following table for examples of items that require drying without heat. Use the AIR DRY Cycle, or place the items on a line or rack to air dry.

Type of Load	AIR DRY Cycle*
DELICATE FABRICS Sheer curtains (2 or 3 panels), gauze, lace, etc. (Use AIR DRY/AIR FLUFF if low heat is not available.)	20-30 min.
RUBBER, PLASTIC, HEAT-SENSITIVE FABRICS Foam rubber – Pillows, padded bras, stuffed toys <ul style="list-style-type: none"> • Make sure coverings are securely stitched. • Shake and fluff pillows by hand several times during the cycle. • Make sure pillows are completely dry. Foam rubber pillows take a long time to dry. Plastic – Shower curtains, tablecloths Rubber-backed rugs Olefin, polypropylene, sheer nylon	20-30 min. 20-30 min. 40-50 min. 10-20 min.

*Reset time, as needed, to allow items to dry completely.

Your dryer sounds a signal when a drying cycle is finished.

The signal is helpful when you are drying permanent press, synthetics, and other items. These items should be removed from the dryer as soon as it stops in order to prevent wrinkles.

- On some models, the volume of the signal can be adjusted.



PUSH TO START BUTTON

Use this control to start the dryer. Be sure the dryer door is closed.

Opening the door stops the dryer. It will not start again until you close the door and press the PUSH TO START Button. Be sure the Cycle Selector Control (Timer) is still on a dry setting.



SOFT-HEAT® System guards against overdrying. This helps your fabrics retain the natural moisture they need, prevents static, and reduces pilling – the formation of small lint-like balls on the surface of garments. Pilling is the natural result of washing and wearing of garments.

Kenmore dryers help prevent overdrying so you get outstanding fabric care. In the AUTO DRY and TIMED DRY Cycles, clothes are dried at the temperature you selected until the last few minutes of the cycle. The dryer then switches to low heat.

COOL DOWN

Approximately ten minutes before the end of the AUTO DRY and TIMED DRY Cycles, clothes are tumbled without heat to help reduce wrinkles and make clothes more comfortable to handle.

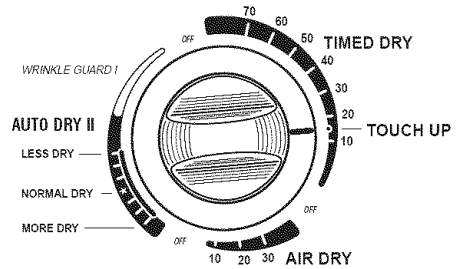

Soft Heat System

USING WRINKLE GUARD

WRINKLE GUARD helps keep your permanent press items wrinkle-free when you don't unload the dryer promptly at the end of the **AUTO DRY** Cycle.

If you do not open the door at the end of the **AUTO DRY** Cycle, **WRINKLE GUARD** will tumble the clothes without heat for 30 minutes.

- This action will be continuous unless you open the dryer.

During **WRINKLE GUARD**, the End-of-Cycle **SIGNAL** will sound every 5 minutes.

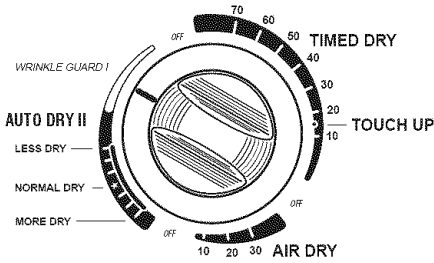

Soft Heat System

DRY RACK

On some models, a dry rack was shipped on top of your dryer. Remove and discard shipping blocks before using. The dry rack may look slightly different than the one shown below.

When you use the dry rack, the heated air inside the dryer flows in a concentrated pattern to allow efficient and uniform drying. The dry rack also reduces noise when drying items that have buckles.

Use the drying rack with the **TIMED DRY** or **AIR DRY** Cycles only. This allows you to machine dry items for a specific length of time without tumbling.

To Use the Dry Rack:

STEP 1. Open dryer door.

STEP 2. Put rack into the drum, fitting rear legs into the grooves in the back wall of the dryer. Then push in rack and drop the front legs into position on dryer opening as shown.

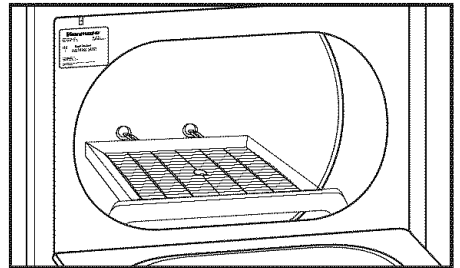

STEP 3. Place wet items on top of the dry rack. Allow space around items for air to circulate. The rack does not move, but the drum will rotate. Make sure items do not hang over the edges or between rack grill.

STEP 4. Close dryer door.

STEP 5. Use the TIMED DRY or AIR DRY Cycle. Refer to the table below.

STEP 6. Set the FABRIC/TEMPERATURE Control, if available. Refer to the table below.

STEP 7. Start the dryer.

To remove the dry rack, push it back to release rear leg springs and lift out.

Suggested Items for Rack Drying	FABRIC/TEMPERATURE Setting	Cycle Selector (Timer) Setting	Minutes*
1. Washable wool items (block to shape and lay flat on rack)	DELICATE	TIMED DRY	60
2. Stuffed toys (cotton or polyester fiber filling)	COTTON	TIMED DRY	60
3. Stuffed toys (foam rubber filling)	AIR DRY		90
4. Galoshes (rubber)	AIR DRY		20
5. Foam rubber pillows	AIR DRY		90
6. Tennis shoes	AIR DRY		30-40

*Reset time as needed to complete drying.

LAUNDRY TIPS

PREPARING CLOTHES FOR DRYING

Follow these recommendations to help save on utility bills and prolong the life of your garments.

- Refer to your Washer Owner's Manual for proper washing techniques and additional laundry tips.
- See page 5 of this manual for Important Safety Instructions.

DRYING TIPS

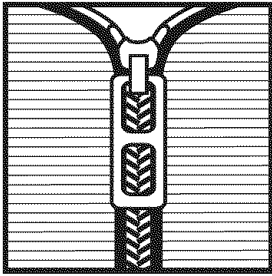

- Close zippers, snaps, and hooks to avoid snagging other items. Remove heat-sensitive trim that can be damaged by drying. Tie strings and sashes so they will not tangle.
- Check garments for spots and stains left after washing. Do not tumble these items. Heat may permanently set stains.
- Check pockets before drying. Sharp or metal objects can damage your dryer. Do not lay these objects on your dryer, they can damage the finish. Turn pockets of heavy items inside out for even drying.
- Place small items such as baby socks or hankies in laundry bag for easy removal.
- Articles to be ironed should be removed while still damp.

SORTING CLOTHES

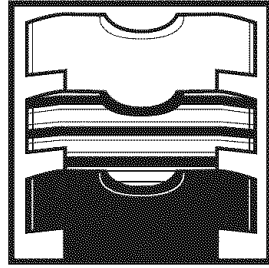

- Separate dark colors from light colors; colorfast from non-colorfast. Items properly sorted by color for washing are usually properly sorted for drying.
- Separate heavy fabrics (denim, towels) from light fabrics (synthetics, permanent press).
- Separate lint givers (towels, chenille) from lint takers (corduroy, synthetics, permanent press). When possible, turn lint takers inside out.

CHOOSING LOAD SIZES

- Mix large items with small items. Load the dryer by the amount of space items take up, not by their weight. Do not overload the dryer. Overcrowding causes uneven drying and wrinkling, and can cause items to wear out faster (because of pilling).
- You may need to rearrange large items (sheets, blankets, tablecloths) during a cycle to reduce balling or rolling up.
- For better tumbling action, when drying only a few small items, add one or two lint-free towels. This also prevents small lightweight items from blocking airflow.

	SUPER CAPACITY	EXTRA-LARGE CAPACITY
Heavy Work Clothes	4 jeans	3 jeans
	4 workpants	3 workpants
	2 workshirts	2 workshirts
	1 sweatshirt	1 sweatshirt
	1 sweatpants	1 sweatpants
Mixed Load	3 sheets (1 king, 2 twin)	3 sheets (1 king, 2 twin)
	4 pillowcases	2 pillowcases
	2 shirts	2 shirts
	2 blouses	2 blouses
	8 T-shirts	6 T-shirts
	6 shorts	5 shorts
	8 handkerchiefs	6 handkerchiefs
	Towels	9 bath towels
9 hand towels		8 hand towels
10 wash cloths		9 wash cloths

USING DRYER FABRIC SOFTENERS

Dryer fabric softeners are recommended for reducing static cling. Always follow package instructions carefully.

- Put one fabric softener sheet on top of the load before starting the dryer. Do not add a fabric softener sheet after the drying cycle has started. Instant heat can cause the fabric softener to spot fabrics.
- Remove fabric softener stains by wetting the stains and rubbing them with liquid detergent or bar soap and rewash.
- Some fabric softeners can clog the lint screen and slow drying. Use fabric softeners labeled as dryer safe.

SAVING ENERGY

- Use the AUTO DRY Cycle to dry most loads.
- Dry full loads only. Do not overdry.
- Avoid overloading dryer, adding wet items to a partly dried load, or opening the door unnecessarily.
- Shorten drying times by exhausting dryer properly and cleaning exhaust vent and outside exhaust hood as needed.
- Keep the lint screen clean.
- Use dryer where room air temperature is above 45°F.
- Sort loads by fabric weight and type.

CARING FOR YOUR DRYER

This section explains how to care for your dryer properly and safely.

Proper care of your dryer can extend its life and help you avoid costly service calls.

CLEANING YOUR DRYER

EXTERIOR

Use a soft, damp cloth to clean the cabinet and console. Avoid using harsh abrasives. Do not put sharp metal objects on or in your dryer. They can damage the finish.

INTERIOR

⚠ WARNING

Explosion Hazard
Use nonflammable cleaners.
Failure to do so can result in death, explosion, fire, or burns.

Garments that contain unstable dyes, such as denim blue jeans or brightly colored cotton items, may discolor the dryer drum.

To clean dryer drum:

STEP 1. Make a paste with detergent and very warm water and apply to a soft cloth. Continue with STEPS 2-4.

or

STEP 1a. Spray nonflammable liquid household cleaner on the stained area. Continue with STEPS 2-4.

STEP 2. Scrub area until all excess dye is removed.

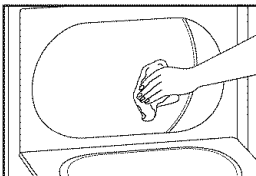

STEP 3. Wipe thoroughly with a damp cloth.

STEP 4. Tumble a load of clean towels for 20 minutes to dry.

CLEANING THE LINT SCREEN

Remove Lint Before Every Load

The lint screen is located on top of your dryer. Clean it before every load. A screen blocked by lint can increase drying time.

To clean:

STEP 1. Pull the lint screen straight up.

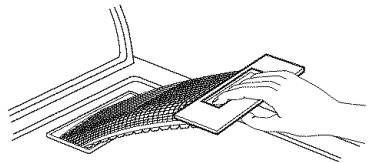

STEP 2. Roll lint off the screen with your fingers. Do not rinse or wash screen to remove lint. Wet lint is hard to remove.

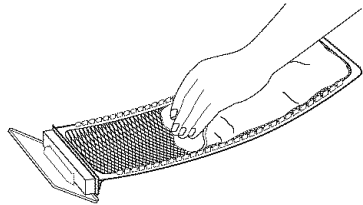

STEP 3. Push the lint screen firmly back into place.

IMPORTANT:

- Do not run the dryer with the lint screen loose, damaged, blocked, or missing. Doing so can cause overheating and damage to both the dryer and fabrics.
- Some towels made of synthetic fibers and natural fibers (polyester and cotton blends) may shed more lint than other towels, causing your dryer's lint screen to fill up faster. Be sure to remove lint from the lint screen before and after drying new towels.

Wash Lint Screen As Needed

Laundry detergents and fabric softeners can cause a residue buildup on the lint screen. Wash the lint screen with a nylon brush if it becomes clogged due to a residue buildup.

To wash:

STEP 1. Wet both sides of lint screen with hot water.

STEP 2. Wet a nylon brush with hot water and liquid detergent; scrub lint screen with the brush to remove residue buildup.

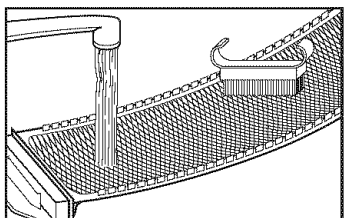

STEP 3. Rinse lint screen with hot water.

STEP 4. Thoroughly dry lint screen with a clean towel; replace in dryer.

CHECKING FOR OBSTRUCTED AIRFLOW

From time to time, you may find it helpful to check your dryer and exhaust system for proper airflow. Poor airflow can result in longer drying times.

To check for obstructed airflow:

STEP 1. Check to ensure nothing is blocking ventilation slots on dryer rear panel.

STEP 2. Inspect exhaust hood. It should not be blocked or obstructed.

REMOVING ACCUMULATED LINT

To remove accumulated lint from exhaust vent:

STEP 1. Disconnect exhaust vent from the dryer.

STEP 2. Clean one section of vent at a time until you reach the exhaust hood. To clean out lint, you can use the hose attachment on your vacuum, or use a pole or wire with a feather duster or rag attached.

STEP 3. Reconnect vent as described in the "INSTALLATION INSTRUCTIONS" of this Owner's Manual.

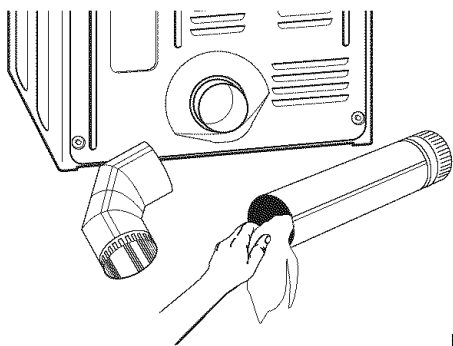

To remove accumulated lint from inside the dryer:

Lint can gather inside the dryer and be fuel for a fire. Lint should be removed every 2 to 3 years, or more often, depending on dryer usage. Cleaning should be done by a qualified service person. Instructions for removing accumulated lint can be found in the Do-It-Yourself repair manual for Kenmore dryers. To order this manual, please call 1-800-366-7278 from anywhere in the United States. The part number is 787207.

CHANGING THE DRUM LIGHT

The dryer light automatically turns on inside the dryer drum when you open the door. If your dryer has a drum light, it will look like one of the styles on this page.

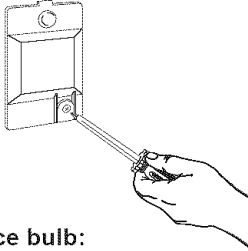

To replace bulb:

STEP 1. Disconnect power.

STEP 2. Open the dryer door. Remove the light bulb cover from the back wall of the dryer by removing the screw located in the lower right corner of the cover.

STEP 3. Check that the light bulb is screwed in tightly. The vibration of the dryer may cause the bulb to come loose. If this is not the problem, remove the light bulb by turning it counterclockwise.

IMPORTANT: Replace the bulb with a 25-watt, 120V A.C. bulb only.

STEP 4. Install light bulb by turning it clockwise.

STEP 5. Replace light bulb cover.

STEP 6. Plug in power supply cord or turn on electric supply.

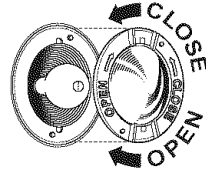

To replace bulb:

STEP 1. Disconnect power.

STEP 2. Open the dryer door. Turn the drum light lens clockwise and remove it.

STEP 3. Check that the light bulb is screwed in tightly. The vibration of the dryer may cause the bulb to come loose. If this is not the problem, remove the light bulb by turning it counterclockwise.

IMPORTANT: Replace the bulb with a 40-watt, 120V A.C. bulb only.

STEP 4. Install light bulb by turning it clockwise.

STEP 5. Find the locking pins on the drum light lens and place them directly over the matching notches on drum light housing. Push lens in and turn counterclockwise to lock it in place.

STEP 6. Plug in power supply cord or turn on electric supply.

MOVING CARE

- Disconnect power.
- Close shut-off valves in gas supply line and behind the dryer front panel.
- Disconnect gas pipe and remove fittings that stick out from dryer.
- Cap the open fuel line running to gas meter.
- Make sure leveling legs are secure in dryer base.
- Use masking tape to secure dryer door.

VACATION CARE

- Disconnect power.
- Clean lint screen.

TROUBLESHOOTING

Most laundering problems are easily solved if you understand the cause. Using the tables below will save you

time and money by helping you avoid unnecessary service calls.

Problem	Possible Cause	Solution
Not Drying Satisfactorily	Lint screen is clogged with lint.	Clean lint screen.
	Restricted air movement. Exhaust vent or outside exhaust hood is clogged with lint.	Run dryer for 5-10 minutes. Hold hand under outside exhaust hood to check air movement. If you do not feel air moving, clean exhaust system of lint or replace exhaust vent with rigid or flexible heavy metal vent (see "INSTALLATION," Section D).
	Exhaust vent is crushed or kinked.	Replace with rigid or flexible heavy metal vent (see "INSTALLATION," Section D).
	One fuse is blown or circuit breaker is tripped. The dryer will appear to operate, but you will not get any heat.	Replace fuse or reset breaker.
	Gas valve on supply line is closed.	Open all valves.
	Timer or the temperature control is set on AIR DRY.	Select the right cycle for the types of garments being dried (see "OPERATION").
	Load not contacting the sensor strips and automatic cycle ending early.	Level dryer (see "INSTALLATION," Section B).
	Fabric softener sheets blocking outlet grill.	Use only one softener sheet per load and only use it once.
	Dryer located in room with temperature below 45°F.	Move dryer where it can operate in ambient air temperatures above 45°F.
	Large amount of moisture in the load.	Expect longer dry times with items that hold more moisture (cottons).
Cold rinse water used.	Expect longer dry times, but you are saving energy and reducing wrinkles.	
Load too large and bulky to dry quickly.	Separate load to tumble freely.	
Dryer Will Not Run	Power cord not firmly plugged into a live circuit with proper voltage.	Plug power cord into a live circuit.
	Fuses blown or circuit breakers tripped.	Replace fuses or reset breakers.

Problem	Possible Cause	Solution
Dryer Will Not Run (cont'd)	Using a regular fuse.	Replace with a time-delay fuse.
	Dryer door not firmly closed.	Close dryer door tightly.
	PUSH TO START Button not firmly pressed.	Press PUSH TO START Button again.
	Controls not set in an ON position.	Reset controls in an ON position.
Lint in Load	Lint screen is clogged.	Clean lint screen. Check for air movement.
	Improper sorting.	Sort lint givers from lint takers and by color.
	Load is too big or heavy.	Dry smaller loads so lint can be carried to the lint screen.
	Load is overdried.	Use correct dryer settings for fabric. Overdrying can cause lint-attracting static (see "OPERATION").
	Paper or tissue in pockets.	Clean out pockets before drying.
	Pilling being mistaken for lint.	Pilling (surface fuzz) is caused by normal wear and laundering.
Stains on Load	Improper use of fabric softener in washer.	Use fabric softener sheets in dryer. Add at beginning of cycle when load is cold.
	Drying soiled items.	Items need to be clean before being dried.
Items Shrinking	Overdrying.	Match dryer settings to fabric type (see "OPERATION").
	Poor garment quality.	Check quality of garment before purchasing.
	Manufacturer's care label instructions not followed.	Follow fabric care label instructions carefully.
Loads are Wrinkled	Overloading.	Dry smaller loads that can tumble freely.
	Overdrying.	Match dryer settings to fabric type (see "OPERATION").
	Load left in dryer at the end of cycle.	Remove load as soon as tumbling stops.
Odors	Household chemicals, paint, or varnish being drawn into dryer.	Do not use dryer while these chemical fumes are in the air.
Unusual Sounds	Thumping of rollers when dryer has set.	Thump will go away after 5 minutes of drying.
	Clicking – gas valve clicking.	Normal operation.

SEARS MAINTENANCE AGREEMENT

KENMORE DRYERS

“We Service What We Sell” is our assurance that you can depend on Sears for service. Your Kenmore Gas Dryer has added value when you consider that Sears has service units nationwide, staffed with professional technicians trained on all appliances Sears sells. They have the knowledge and skills, tools, parts, and equipment to ensure our pledge to you that “We Service What We Sell.”

Sears Maintenance Agreement

Maintain the value of your Kenmore Gas Dryer with a Sears Maintenance Agreement. Kenmore Gas Dryers are designed, manufactured, and tested for years of dependable operation. Yet, any appliance may require service from time to time. The Sears Maintenance Agreement offers you an outstanding service program for your Kenmore Gas Dryer.

The Sears Maintenance Agreement

- Is your way to buy tomorrow's service at today's prices.
- Eliminates repair bills resulting from normal use.
- Allows for as many service calls as required.
- Provides an annual Preventive Maintenance Check at your request to keep your dryer in proper running condition.

**For more information,
call 1-800-827-6655.**

For the repair or replacement parts you need delivered directly to your home
Call 7 am - 7 pm, 7 days a week
1-800-366-PART
(1-800-366-7278)

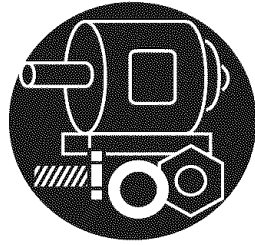

For in-home major brand repair service
Call 24 hours a day, 7 days a week
1-800-4-REPAIR
(1-800-473-7247)



For the location of a Sears Parts and Repair Center in your area
Call 24 hours a day, 7 days a week
1-800-488-1222

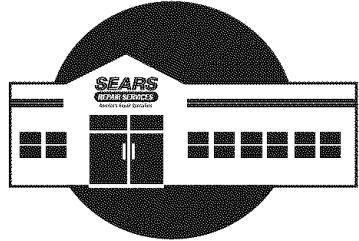

For information on purchasing a Sears Maintenance Agreement or to inquire about an existing Agreement
Call 9 am - 5 pm, Monday - Saturday
1-800-827-6655



When requesting service or ordering parts, always give the following information:

- Product Name
- Part Name
- Model Number
- Part Number

