

Operator's Manual

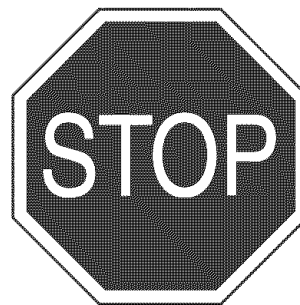

Model No. 486.248472

FRONT SCOOP TRACTOR ATTACHMENT



DO NOT RETURN TO STORE
For Missing Parts or Assembly
Questions Call 1-866-576-8388

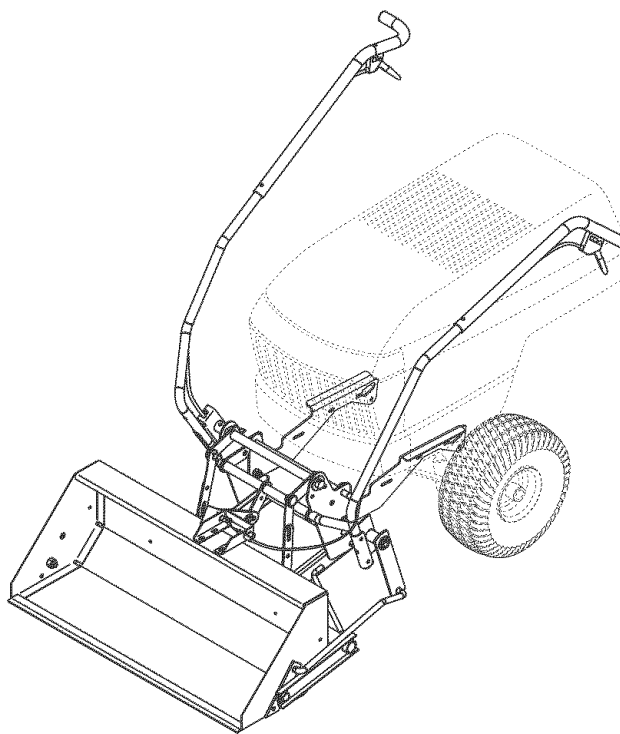

CAUTION:

Before using this product, read this manual and follow all Safety Rules and Operating Instructions.

- Safety
- Assembly
- Operation
- Maintenance
- Parts

Sears, Roebuck and Co., Hoffman Estates, IL 60179 U.S.A.
www.sears.com/craftsman

PRINTED IN U.S.A.

FORM NO. 48205 (REV. 5/01/07)

TABLE OF CONTENTS

| | | | |
|-------------------------------|----|--------------------------------|-----------|
| WARRANTY | 2 | MAINTENANCE | 18 |
| SAFETY RULES..... | 3 | TROUBLESHOOTING..... | 19 |
| FULL SIZE HARDWARE CHART..... | 4 | REPAIR PARTS ILLUSTRATION..... | 20 |
| CARTON CONTENTS..... | 6 | REPAIR PARTS LIST..... | 21 |
| ASSEMBLY..... | 7 | SLOPE GUIDE | 23 |
| OPERATION..... | 17 | PARTS ORDERING/SERVICE | Back Page |

WARRANTY

ONE YEAR FULL WARRANTY

When operated and maintained according to the instructions supplied with it, if this Front Scoop Tractor Attachment fails due to a defect in material or workmanship within one year from the date of purchase, call 1-800-4-MY-HOME® to arrange for free repair (or replacement if repair proves impossible).

If this product is used for commercial or rental purposes, this warranty applies for only 90 days from the date of purchase.

This warranty gives you specific legal rights, and you may also have other rights which vary from state to state.

Sears, Roebuck and Co., D817WA, Hoffman Estates, IL 60179

The model number and serial number will be found on a decal attached to the bucket.

You should record both the serial number and the date of purchase and keep in a safe place for future reference.

MODEL NUMBER: 486.248472

SERIAL NUMBER: _____

DATE OF PURCHASE: _____



SAFETY RULES



Any power equipment can cause injury if operated improperly or if the user does not understand how to operate the equipment. Exercise caution at all times when using power equipment.

- Read this operator's manual before attempting to assemble or operate the scoop attachment.
- Read the vehicle owner's manual and know how to operate your vehicle before using the scoop attachment.
- Never carry passengers in the scoop bucket. It has not been designed to carry passengers.
- Never allow children to operate the vehicle or the scoop attachment.
- Do not allow adults to operate the vehicle or scoop attachment without proper instructions.
- Always begin with the transmission in first (low) and gradually increase speed as conditions permit.
- Drive the tractor at reduced speed over rough terrain and hillsides or near creeks and ditches to prevent tipping over and loss of control. Do not drive too close to a creek or ditch.
- Never ram the scoop into material at high speed.
- Vehicle braking and stability may be affected with the attachment of this scoop. Do not fill the scoop to maximum weight capacity without checking the capability of the vehicle to safely drive and stop with the scoop attached.
- Before operating vehicle on any grade (hill) refer to the safety rules in the vehicle owner's manual concerning safe operation on slopes. Refer also to the slope guide on page 23 of this manual. **Stay off steep slopes!**
- Follow maintenance and lubrication instructions as outlined in this manual.



Look for this symbol to point out important safety precautions. It means — **Attention!! Become alert!! Your safety is involved.**

ACCESSORIES AND ATTACHMENTS

These and other accessories are recommended for use with your unit. Call 1-800-4-MY-HOME® to find out if they are available. If available, they may be purchased at most Craftsman outlets or by calling 1-800-4-MY-HOME®.

WHEEL WEIGHT

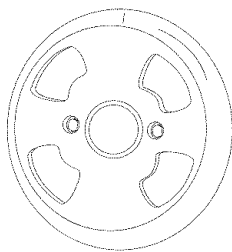

TIRE CHAINS

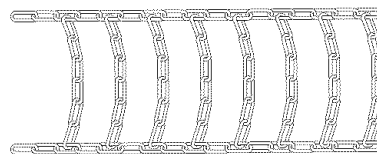

FULL SIZE HARDWARE CHART

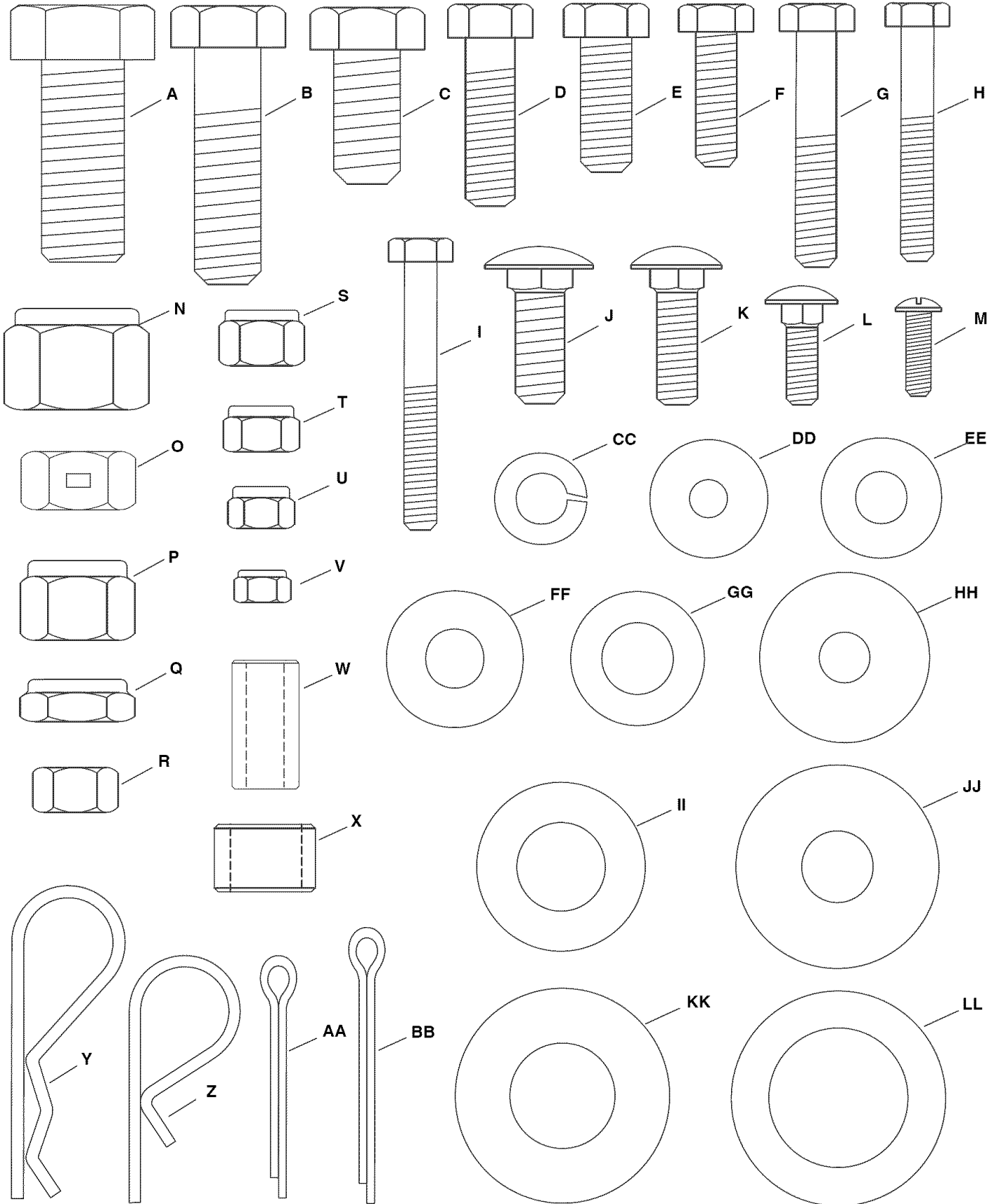

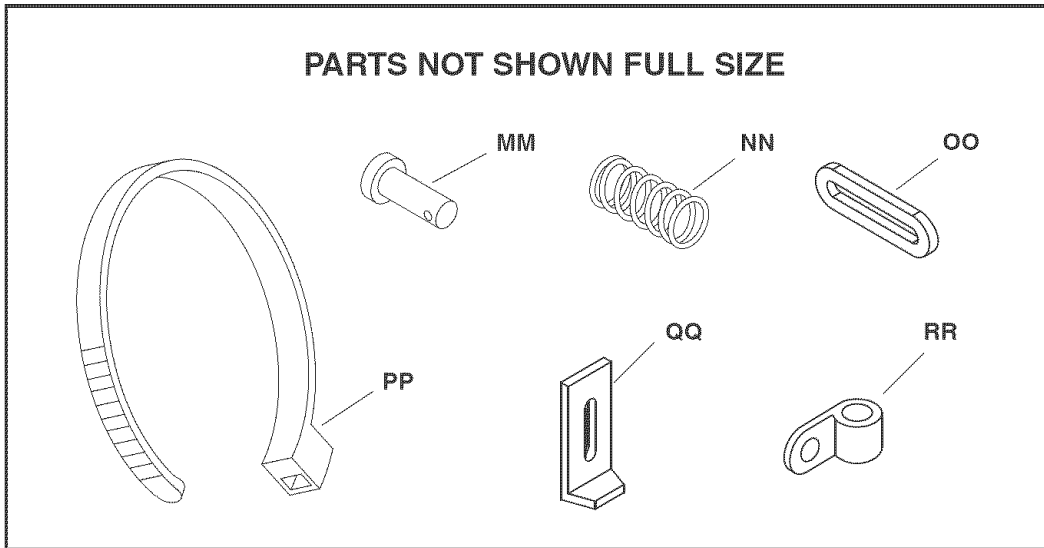

PARTS BAG CONTENTS

Not all parts will be needed for fit-up to any one tractor.
Discard unneeded parts after assembly is finished.

| REF. | QTY. | DESCRIPTION | REF. | QTY. | DESCRIPTION |
|------|------|---------------------------------------|------|------|---------------------------|
| A | 2 | Hex Bolt, 5/8" x 1-1/2" | W | 1 | Spacer, 1" Long |
| B | 2 | Hex Bolt, 1/2" x 1-3/4" | X | 4 | Spacer, 1/2" Long |
| C | 3 | Hex Bolt, 1/2" x 1" | Y | 3 | Hairpin Cotter, Long |
| D | 2 | Hex Bolt, 3/8" x 1-1/4" | Z | 4 | Hairpin Cotter, Short |
| E | 6 | Hex Bolt, 3/8" x 1" | AA | 6 | Cotter Pin, 1/8" x 1-1/4" |
| F | 4 | Hex Bolt, 5/16" x 1" | BB | 2 | Cotter Pin, 1/8" x 1-1/2" |
| G | 5 | Hex Bolt, 5/16" x 1-3/4" | CC | 6 | Lock Washer, 3/8" |
| H | 2 | Hex Bolt, 1/4" x 1-3/4" | DD | 4 | Washer, 1/4" |
| I | 1 | Hex Bolt, 1/4" x 2" | EE | 8 | Washer, 5/16" |
| J | 6 | Carriage Bolt, 3/8" x 1" | FF | 6 | Washer, 3/8" (Small) |
| K | 2 | Carriage Bolt, 5/16" x 1" | GG | 4 | Washer, 1/2" (Small) |
| L | 2 | Carriage Bolt, 1/4" x 3/4" | HH | 2 | Washer, 3/8" (Large) |
| M | 1 | Slotted Truss Head Bolt, 10-32 x 5/8" | II | 6 | Washer, 5/8" |
| N | 2 | Nylock Nut, 5/8" | JJ | 8 | Washer, 1/2" (Large) |
| O | 1 | Hex Lock Nut, 1/2" | KK | 2 | Washer, 3/4" |
| P | 2 | Nylock Nut, 1/2" | LL | 2 | Washer, 1" |
| Q | 2 | Nylock Jam Nut, 1/2" | MM | 2 | Clevis Pin |
| R | 2 | Hex Nut, 3/8" | NN | 1 | Compression Spring |
| S | 8 | Nylock Nut, 3/8" | OO | 1 | Slotted Stop Bracket |
| T | 12 | Nylock Nut, 5/16" | PP | 6 | Cable Tie |
| U | 5 | Nylock Nut 1/4" | QQ | 2 | Tilt Stop Bracket |
| V | 1 | Nylock Nut, #10-32 | RR | 1 | Hose Clip |

CARTON CONTENTS

1. Bucket Assembly
2. Pin Stop Bracket
3. Lift Frame Assembly
4. Lift Bracket Assembly
5. Tilt Anchor Assembly
6. Right (Long) Side Plate
7. Left (Long) Side Plate
8. Right (Short) Side Plate
9. Left (Short) Side Plate
10. Dump Control Rod
11. Lift Strap Assembly (2)
12. Tilt Bracket Assembly
13. Attachment Rod
14. Dump Handle Tube
15. Lift Handle Tube
16. Dump Control Pin
17. Dump Pivot Bracket
18. Dump Handle Tube Extension
19. Lift Handle Tube Extension

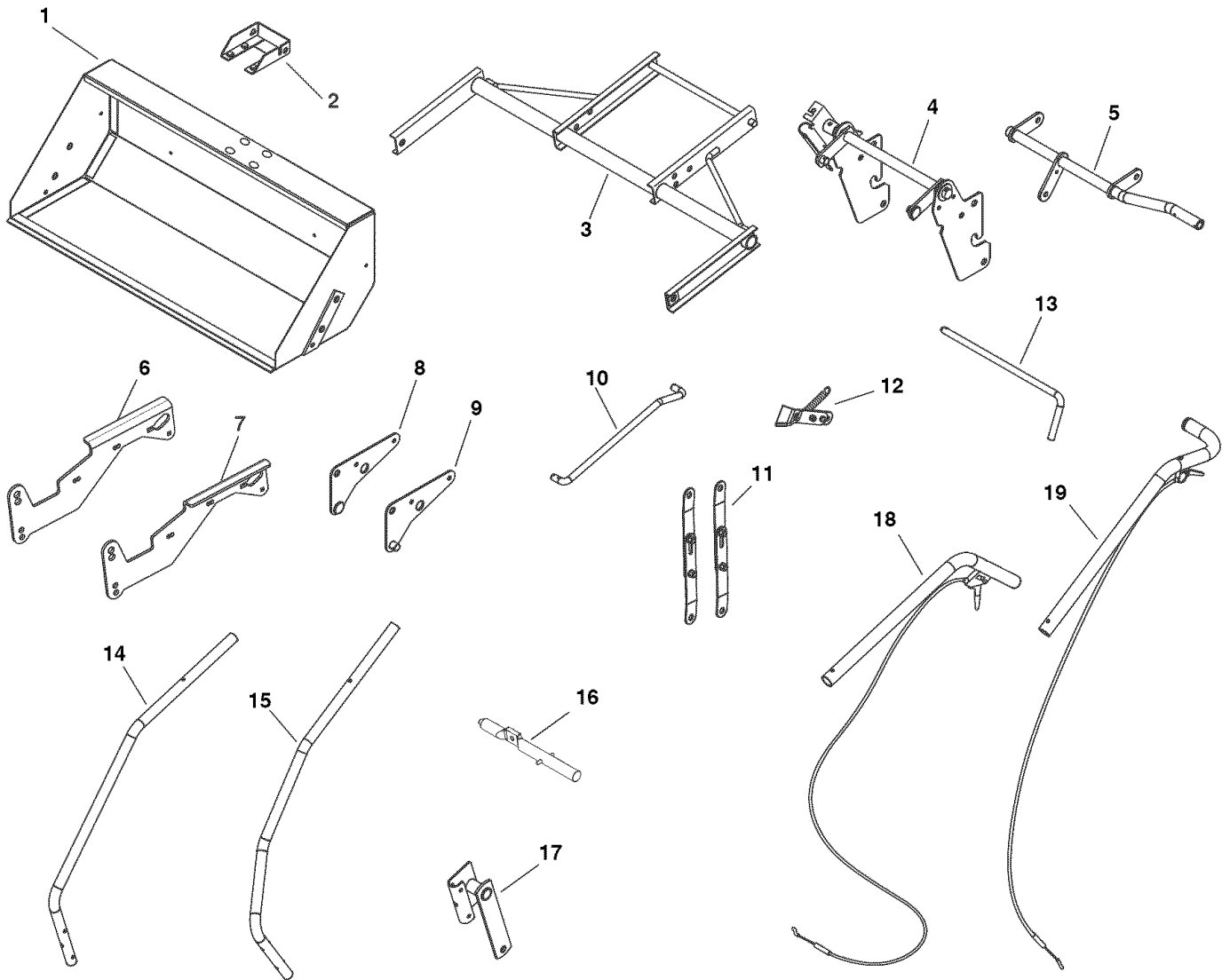

ASSEMBLY

TOOLS REQUIRED FOR ASSEMBLY

- (1) Standard Screwdriver
- (2) 15/16" Wrenches (one should be box-end)
- (2) 3/4" Wrenches
- (2) 9/16" Wrenches
- (2) 1/2" Wrenches
- (2) 7/16" Wrenches
- (1) 3/8" Wrench

ADDITIONAL ITEMS NEEDED

Ruler or Tape Measure
Grease

REMOVE PARTS FROM CARTON

- Remove the hardware pack and all loose parts from the carton.
- Lay cardboard on floor to help prevent scratching of painted parts.
- Lay out and identify all the parts and hardware as shown on pages 4 through 6.

ASSEMBLE SCOOP

STEP 1: INSTALL TWO BOLTS (SEE FIGURE 1)

- Assemble two 3/8" x 1-1/4" hex bolts (D) and 3/8" hex nuts (R), threading the nut all the way onto the bolt until it is tight against the head of the bolt.
- Install a nut/bolt assembly into the bucket assembly and fasten using a 3/8" nylock nut (S). **Tighten.** Repeat for the other side.

STEP 2: INSTALL PIN STOP BRACKET (SEE FIGURE 1)

- Install the pin stop bracket to the top of the bucket assembly using four 5/16" x 1" hex bolts (F), eight 5/16" washers (EE) and four 5/16" nylock nuts (T). Leave the bolts loose enough that the position of the pin stop bracket can be adjusted later.

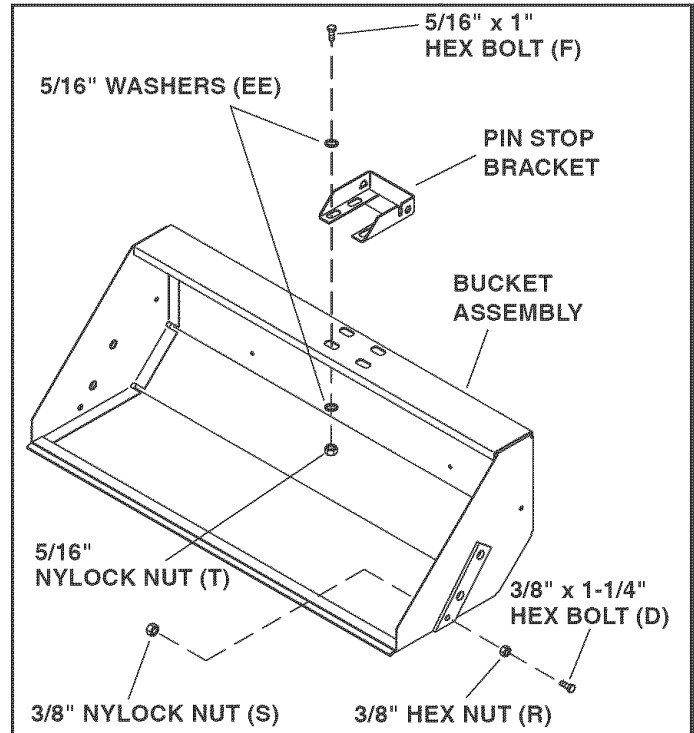

FIGURE 1

STEP 3: INSTALL LIFT FRAME ASSEMBLY (SEE FIGURE 2)

- Apply grease to the mounting surface of the bucket assembly and the inside of the lift frame arms.
- Assemble the lift frame assembly to the bucket assembly using two 5/8" x 1-1/2" hex bolts (A) and 5/8" nylock nuts (N). **Tighten, then loosen** the nuts 1/4 turn, or until the lift frame pivots freely.

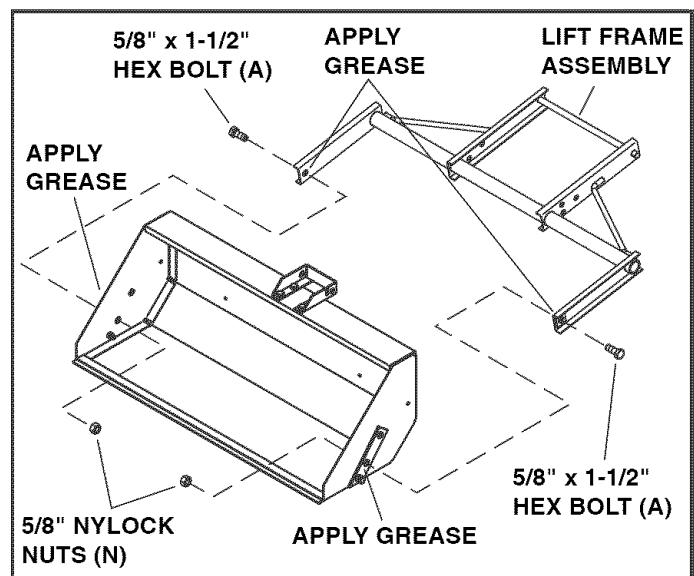

FIGURE 2

**STEP 4: INSTALL LIFT BRACKET ASSEMBLY
(SEE FIGURE 3)**

- Assemble the lift bracket assembly to the lift frame assembly using two 5/8" washers (II) and 1/8" x 1-1/4" cotter pins (AA).

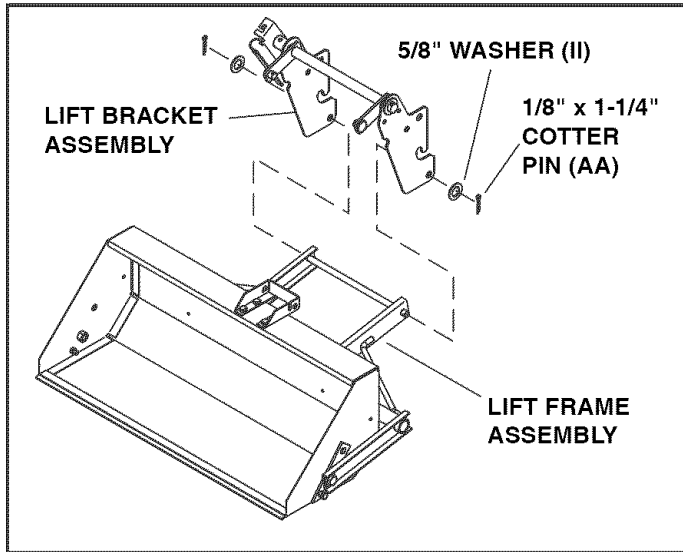

FIGURE 3

**STEP 5: INSTALL TILT ANCHOR ASSEMBLY
(SEE FIGURE 4)**

- Assemble the tilt anchor assembly to the lift bracket assembly using two 1/2" x 1" hex bolts (C) and 1/2" nylock jam nuts (Q). **Tighten.**

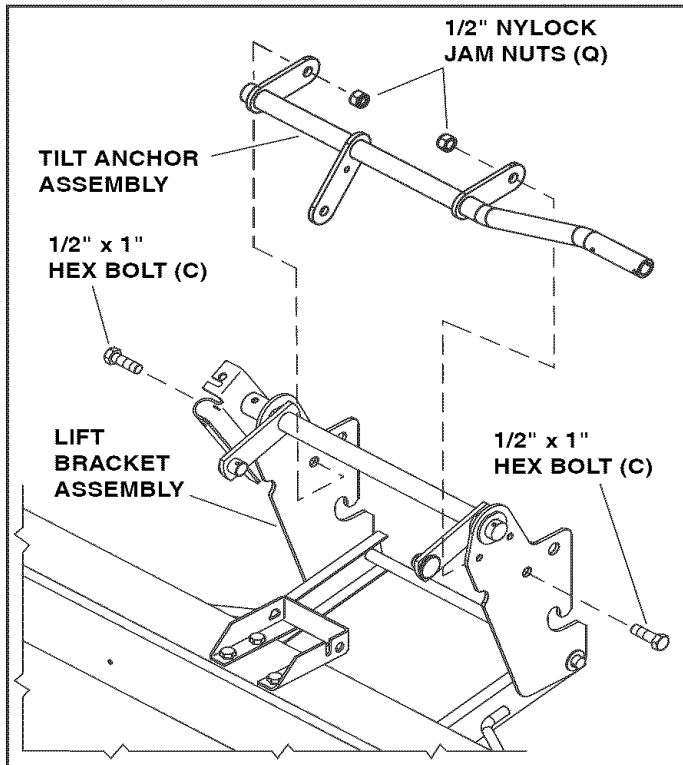

FIGURE 4

**STEP 6: INSTALL LIFT STRAP ASSEMBLIES
(SEE FIGURE 5)**

- **Loosen the bolts and nuts** on the lift strap assemblies 1/4 turn or until the straps will slide back and forth. You will retighten them later in step 26.
- Turn the lift strap assemblies as shown. Install each lift strap assembly to an arm of the lift bracket assembly and then secure with a small 1/2" washer (GG) and a short hairpin cotter (Z).
- Position the lower end of each lift strap assembly to the outside of the lift frame. Fasten to the upper front holes in the lift frame using a 1/2" x 1" clevis pin (MM), 1/2" long spacer (X) and short hairpin cotter (Z) for each assembly.

NOTE: The lift strap assemblies may be installed in the rear mounting holes of the lift frame to increase the lift height, but this will also increase the lifting effort. The front holes give a lift height of about 6-1/2" and require 28 lbs. of force to lift a 150 lb load. The rear holes will give a lift height of about 8-1/2" and require 35 lbs. of force.

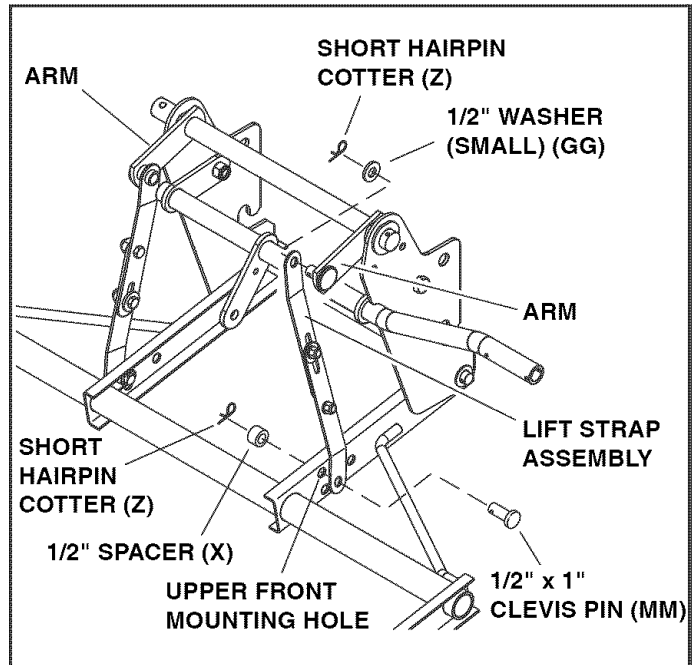

FIGURE 5

Bucket removed for clarity

**STEP 7: INSTALL TILT BRACKET ASSEMBLY
(SEE FIGURE 6 ON NEXT PAGE)**

- **Loosen the bolts and nuts** on the tilt bracket assembly 1/4 turn or until the two plates of the assembly will slide back and forth. You will retighten them later in step 25.
- Lightly apply grease to the end of the arm on the tilt anchor assembly and install the tilt bracket assembly to the arm using a 1/2" x 1" hex bolt (C) and 1/2" hex lock nut (O). **Tighten then loosen** the nut 1/4 turn, or until the tilt bracket assembly pivots freely.
- Install the 1/4" x 2" hex bolt (I) through a 1/4" washer (DD), the 1" long spacer (W) and then through the end of the extension spring on the tilt bracket assembly. Next, insert the end of the bolt into the hole in the arm of the tilt anchor assembly and install the slotted stop bracket (OO), a 1/4" washer (DD) and a 1/4 nylock nut (U) onto the bolt. **Tighten.**

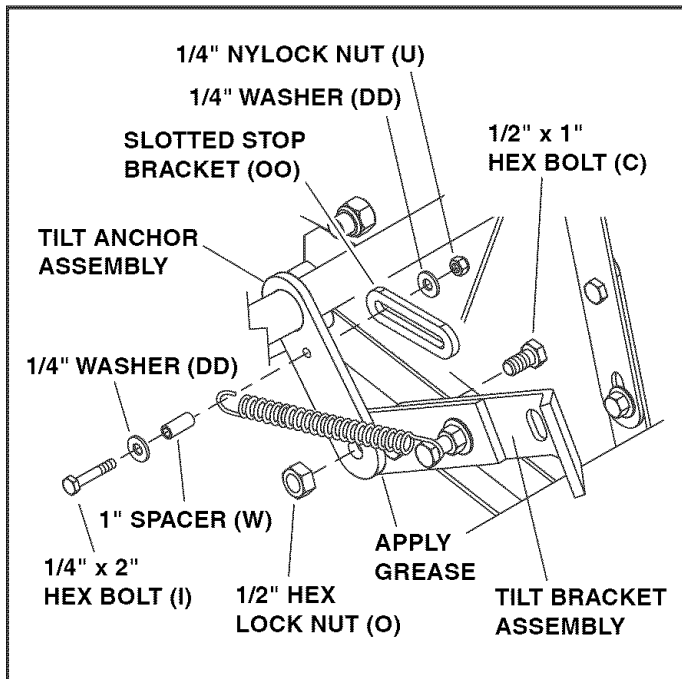

FIGURE 6

**STEP 8: INSTALL DUMP PIVOT BRACKET
(SEE FIGURE 7)**

- Install a 1/8" x 1-1/2" cotter pin (BB) to the inside hole in the shaft shown in figure 7, and then install a 1" washer (LL) onto the shaft. Apply grease to the end of the shaft and install the dump pivot bracket assembly onto the shaft. Install a 1" washer (LL) onto the shaft and secure it using a 1/8" x 1-1/2" cotter pin (BB).

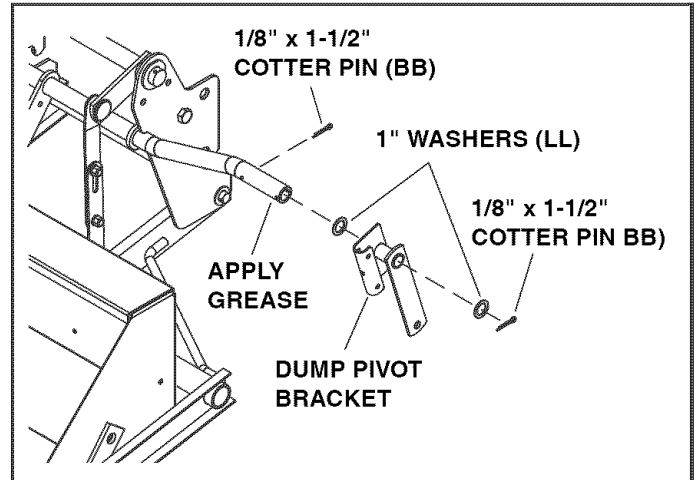

FIGURE 7

**STEP 9: INSTALL DUMP CONTROL ROD
(SEE FIGURE 8)**

- Install a 1/8" x 1-1/4" cotter pin (AA) into the inside hole in each end of the dump control rod. Spread the ends of the cotter pins and wrap around the rod. Install a 5/8" washer (II) onto each end of the control rod.
- Install the dump control rod to the dump pivot bracket and bucket. Fasten using two 5/8" washers (II) and 1/8" x 1-1/4" cotter pins (AA). Spread the ends of the cotter pins and wrap around the rod.

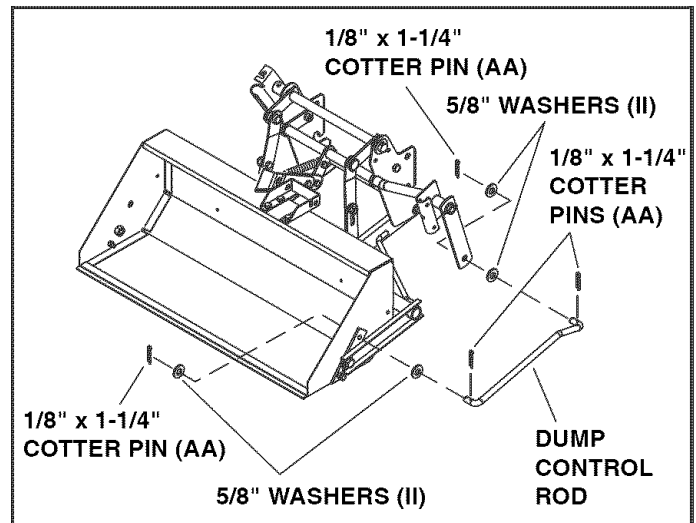

FIGURE 8

**STEP 10: INSTALL TILT STOP BRACKETS
(SEE FIGURE 9)**

- Install a tilt stop bracket (QQ) to each side of the bucket using a 1/4" x 3/4" carriage bolt (L), 1/4" washer (DD) and 1/4" nylock nut (U). **Do not tighten** the nuts until step 27.

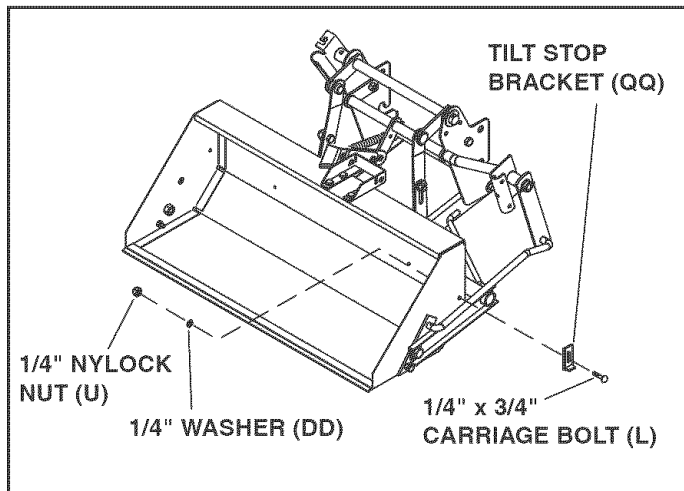

FIGURE 9

**STEP 11: INSTALL LIFT HANDLE TUBE
(SEE FIGURE 10)**

- Install the lift handle tube into the index bracket using two 5/16" x 1-3/4" hex bolts (G) and 5/16" nylock nuts (T).

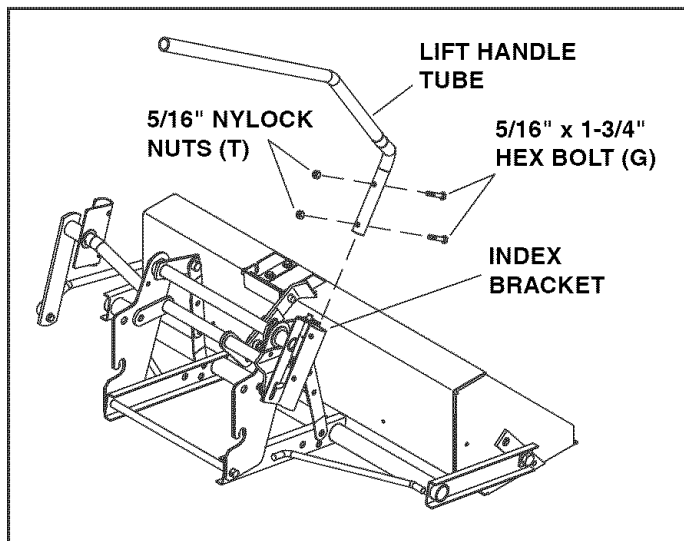

FIGURE 10

**STEP 12: INSTALL LIFT HANDLE TUBE EXTENSION
(SEE FIGURE 11)**

- Install the lift handle tube extension on the lift handle tube using a 1/4" x 1-3/4" hex bolt (H) and 1/4" nylock nut (U).

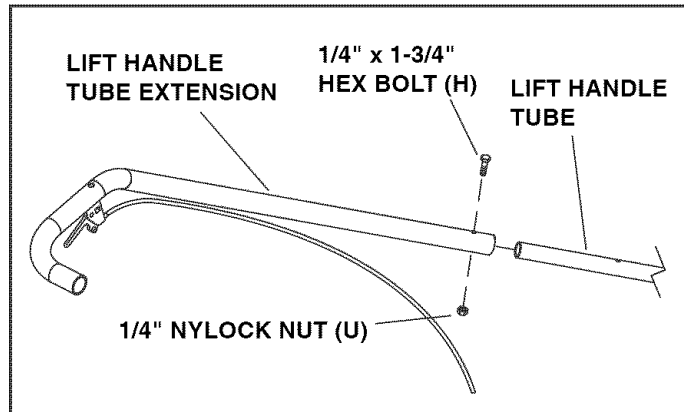

FIGURE 11

**STEP 13: INSTALL LIFT CABLE
(SEE FIGURE 12)**

- Connect the hooked end of the lift cable into the index rod, and install the threaded cable adjuster into the notch in the top of the index bracket, placing a nut on each side of the notch.
- Adjust the cable adjustment nuts so that when the lift trigger is squeezed, the bottom of the index rod raises enough to release from the latched position. The index rod should also lower far enough to lock in the latched position when the trigger is released.
- Attach the lift cable to the lift handle using three cable ties (PP).

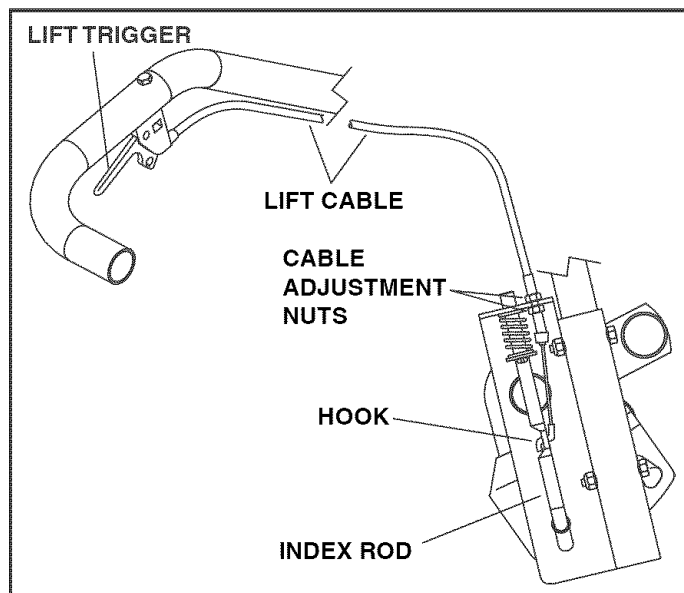

FIGURE 12

**STEP 14: INSTALL DUMP HANDLE TUBE
(SEE FIGURE 13)**

- Install the dump handle tube to the dump pivot bracket assembly using three 5/16" x 1-3/4" hex bolts (G) and 5/16" nylock nuts (T).

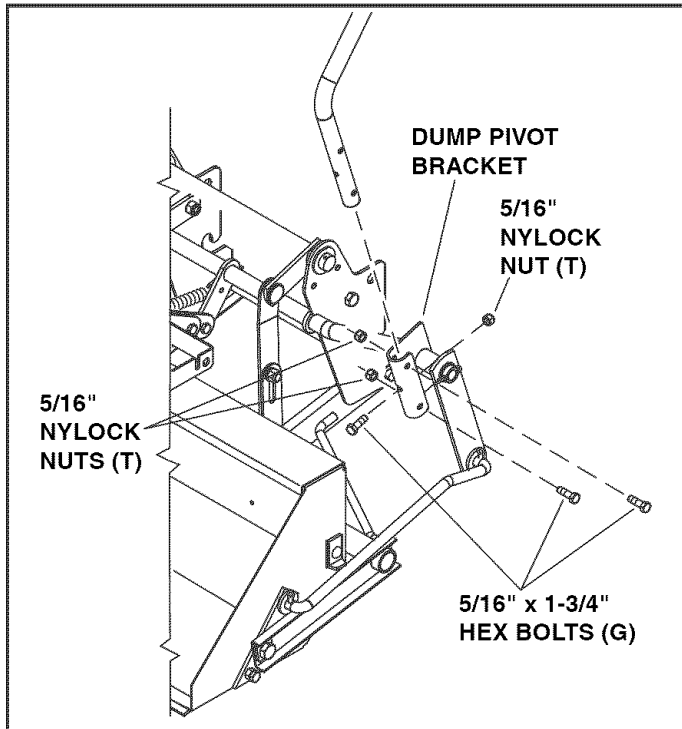

FIGURE 13

**STEP 15: INSTALL DUMP HANDLE TUBE EXTENSION
(SEE FIGURE 14)**

- Install the dump handle tube extension on the dump handle tube using a 1/4" x 1-3/4" hex bolt (H) and 1/4" nylock nut (U).
- Attach the dump cable to the dump handle tube using three cable ties (PP).

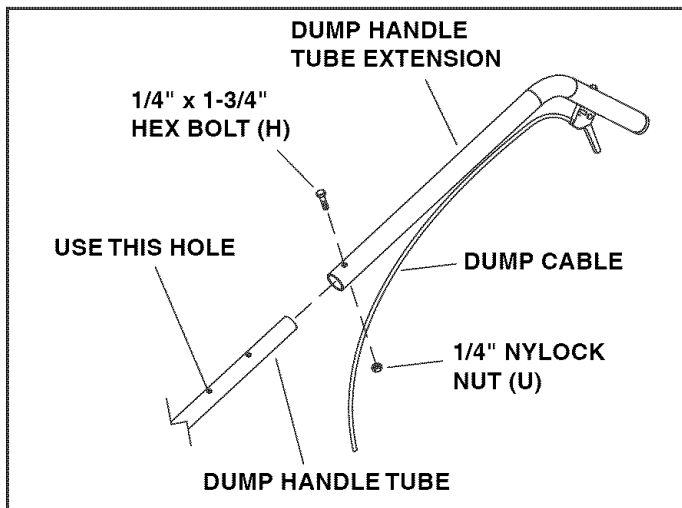

FIGURE 14

**STEP 16: INSTALL DUMP CONTROL PIN
(SEE FIGURE 15)**

- Install a small 1/2" washer (GG) and then the compression spring (NN) onto the dump control pin. Install the dump control pin into the pin stop bracket. Make sure the flat side of the pin faces to the front when finished.
- Connect the hooked end of the dump cable into the hole in the dump control pin. Install the threaded cable adjuster down into the notch in the pin stop bracket, placing a nut on each side of the notch. Adjust and tighten the adjuster nuts so that the tapered end of the dump control pin extends 3/4" through the side of the pin stop bracket.

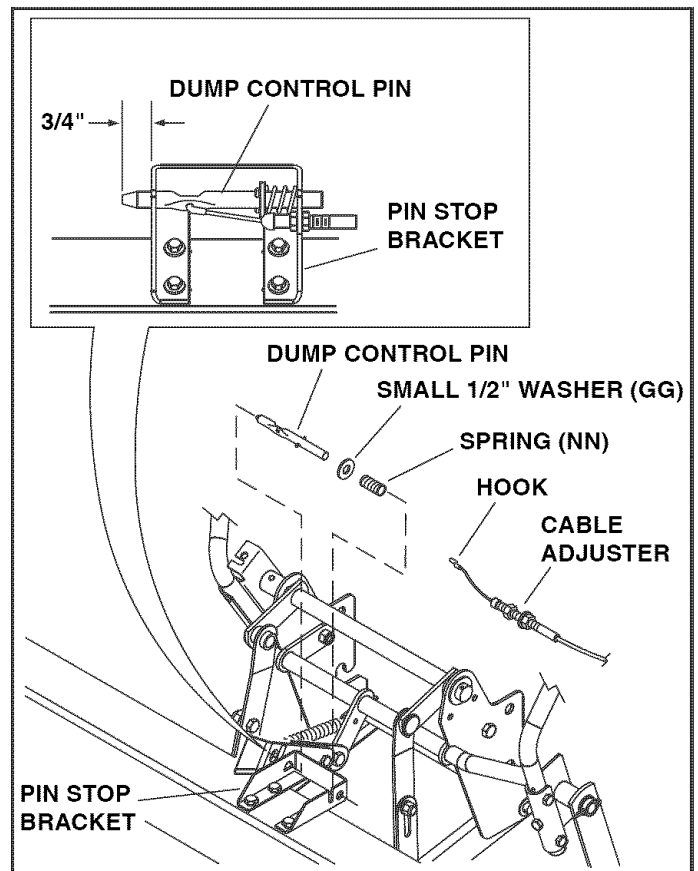

FIGURE 15

**STEP 17: INSTALL HOSE CLIP AND SPACER
(SEE FIGURE 16)**

- Secure the dump cable to the back of the bucket using a hose clip (RR), a #10 x 5/8" truss-head bolt (M) and a #10-32 nylock nut (V).

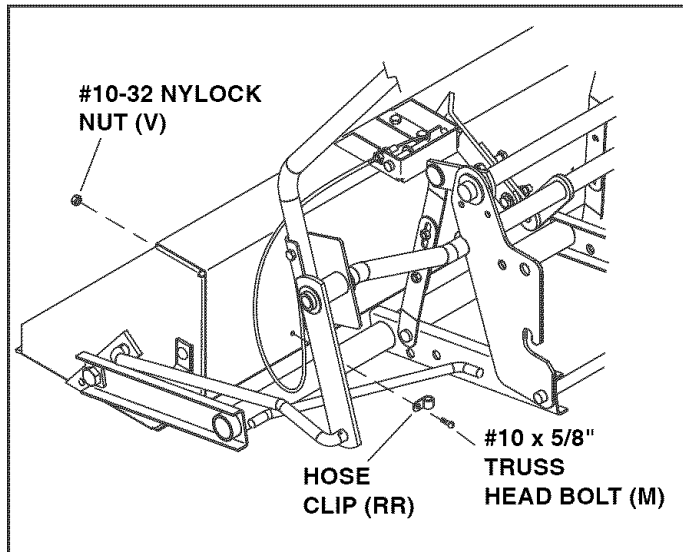

FIGURE 16

INSTALL FRONT SCOOP ON TRACTOR

**STEP 18: IDENTIFY YOUR TRACTOR TYPE
(SEE FIGURE 17)**

- Look underneath the front axle of your tractor. If there is a single mower deck suspension bracket located under the middle of the front axle, continue on to step 19. If your tractor does not have a mower deck suspension bracket underneath the middle of the front axle, skip to step 21 on page 13 or step 23 on page 14 for tractors with dual suspension brackets.

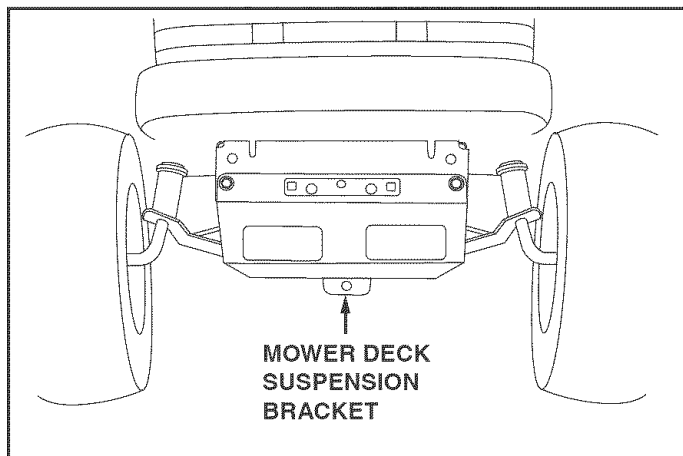

FIGURE 17

**LAWN TRACTORS AND GARDEN TRACTORS
WITH SINGLE SUSPENSION BRACKETS**

**STEP 19: INSTALL SIDE PLATES
(SEE FIGURE 18)**

- Remove any bolts present in the mounting holes on the left side of the tractor frame. **Do not remove** bolts from right side of frame until left side plate has been installed.
- Install the left (long) side plate on the tractor frame using three 3/8" x 1" carriage bolts (J), three 3/8" nylock nuts (S), one 5/16" x 1" carriage bolt (K), one 5/16" nylock nut (T) and three large 1/2" washers (JJ) if needed (see note). **Do not tighten yet.** Repeat for the right side plate.

NOTE: If an engine mounting plate is present (shown with dotted lines) that prevents the side plate from resting flat against the tractor frame, place 1/2" washers (JJ) on the front two 3/8" bolts and on the rear 5/16" bolt to serve as shims between the side plate and the frame.

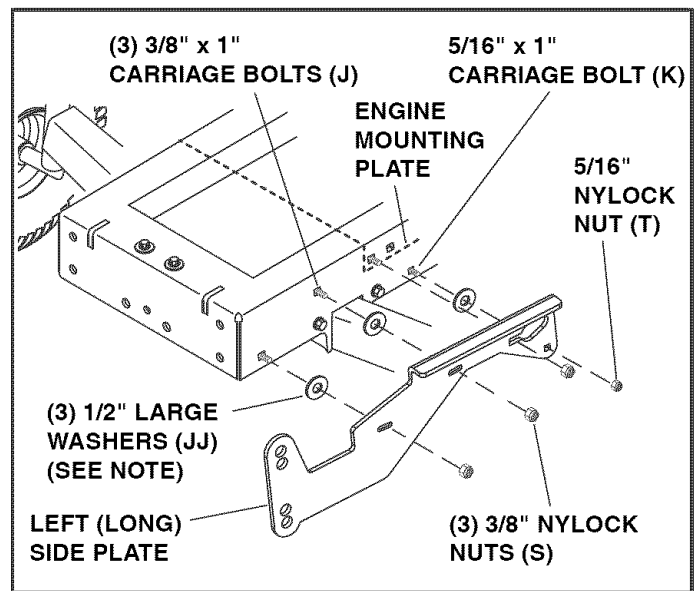

FIGURE 18

**STEP 20: INSTALL FRAME BRACE
(SEE FIGURE 19)**

- Install the frame brace to the inside of the side plates using two 1/2" x 1-3/4" bolts (B), large 1/2" washers (JJ), 1/2" spacers (X) and 1/2" nylock nuts (P). Install the brace in the bottom holes for Garden (GT) Tractors and the second from bottom holes for Lawn (LT) Tractors. **Do not tighten yet.**
- Tighten all nuts on side plates and frame brace.
- **Skip to step 24 on page 15.**

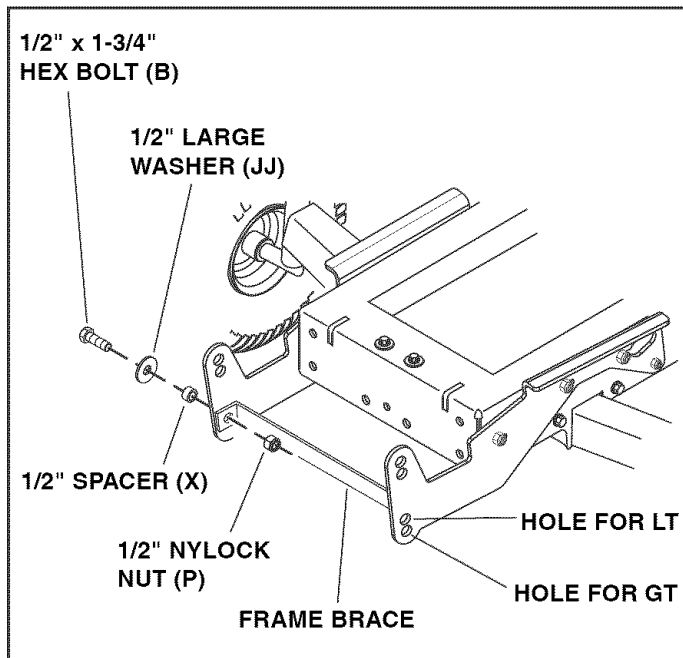

FIGURE 19

LAWN TRACTORS WITH DUAL SUSPENSION BRACKETS

**STEP 21: INSTALL SIDE PLATES
(SEE FIGURE 20)**

- Remove any bolts present in the mounting holes on the left side of the tractor frame. **Do not remove** bolts from right side of frame until done with left side plate.
- Fasten the left (long) side plate to the tractor frame using three 3/8" x 1" hex bolts (E), 3/8" small washers (FF), and 3/8" lock washers (CC). If there is a bracket like the one shown with dotted lines, use a 3/8" large washer (HH) as a shim on the rear bolt. **Do not tighten yet.** Repeat for the right (long) side plate.

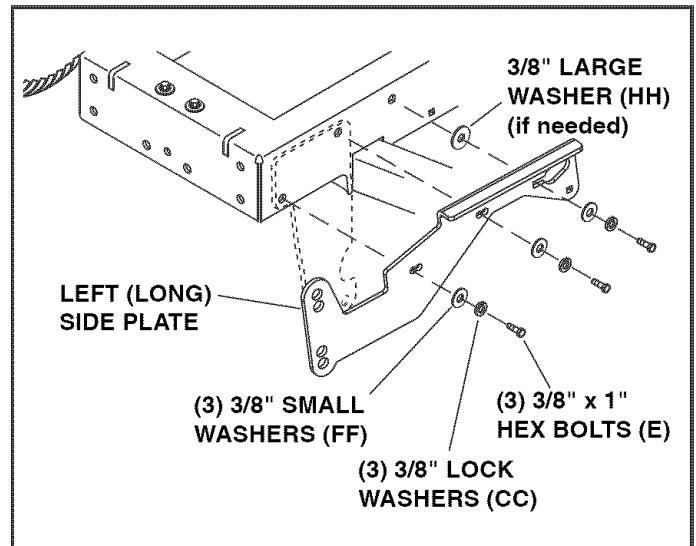

FIGURE 20

STEP 22: INSTALL FRAME BRACE (SEE FIGURE 21)

- Install the frame brace between the side plates using two 1/2" x 1-3/4" bolts (B), large 1/2" large washers (JJ), 1/2" spacers (X) and 1/2" nylock nuts (P). Fasten the brace to the second from bottom holes in the side plates. **Tighten.**
- **Tighten** 3/8" bolts (E) in side plates only until they are snug and the lock washers are flattened.
- **Skip to step 24 on page 15.**

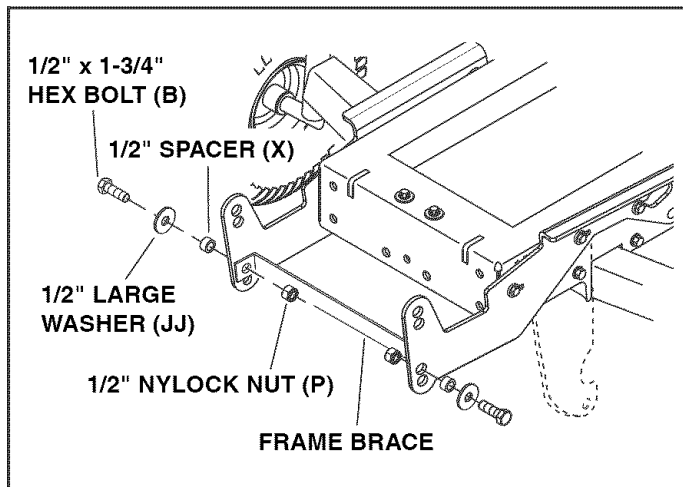

FIGURE 21

GARDEN TRACTORS WITH DUAL SUSPENSION BRACKETS

STEP 23: INSTALL SIDE PLATES (SEE FIGURE 22)

- Remove any bolts present in the mounting holes on the left side of the tractor frame. **Do not remove** bolts from right side of frame until left side plate has been installed.
- Install the left (short) side plate with the pin to the outside using two 3/8" x 1" hex bolts (E) and 3/8" lock washers (CC). Tighten only until bolts are snug and lock washers are flattened. Repeat for the right side plate.
- Install a 3/4" washer (KK) and a long hairpin cotter (Y) to the pin in each side plate. Remove them while mounting the scoop.

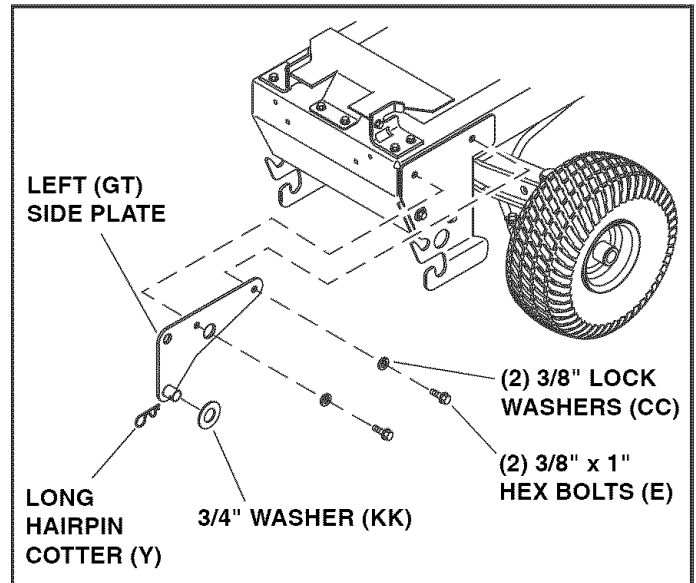

FIGURE 22

INSTRUCTIONS FOR ALL TRACTORS

STEP 24: MOUNT SCOOP TO TRACTOR (SEE FIGURE 23)

- Align the scoop with the side plates on the front of the tractor. Lift the rear of the scoop and slide the notches in the scoop frame onto the bolts or pins in the tractor side plates. Stand on the left side of the tractor and push down on the scoop dump handle until the holes in the scoop frame and the holes in the side plates are aligned. Install the attachment rod through the holes from the left side and secure it with a long hairpin cotter (Y).

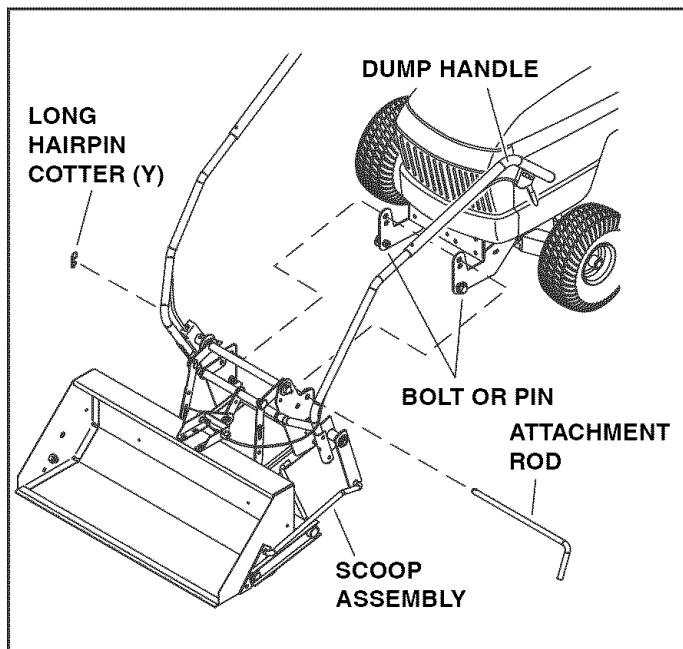

FIGURE 23

STEP 25: ADJUST TILT BRACKET AND PIN STOP BRACKET (SEE FIGURE 24)

- Lower the scoop assembly onto a smooth level surface. For normal use, let the bottom of the bucket rest flat on the ground. For more aggressive scraping action, place 1/4" shims under the rear of the bucket at each end.
- If they are tightened, slightly loosen the two smaller bolts in the tilt bracket. If they are tightened, slightly loosen the four bolts in the pin stop bracket.
- Swing the tilt bracket forward and position the pin stop bracket so the end of the dump control pin inserts into the hole in the tilt bracket.
- Adjust the pin stop bracket so that it is square with the bucket leaving a small gap between the pin stop bracket and the tilt bracket. The taper on the end of the pin should now extend all the way through the tilt bracket. **TIGHTEN** the bolts and nuts in the pin stop bracket
- TIGHTEN** the two bolts and nuts in the tilt bracket.

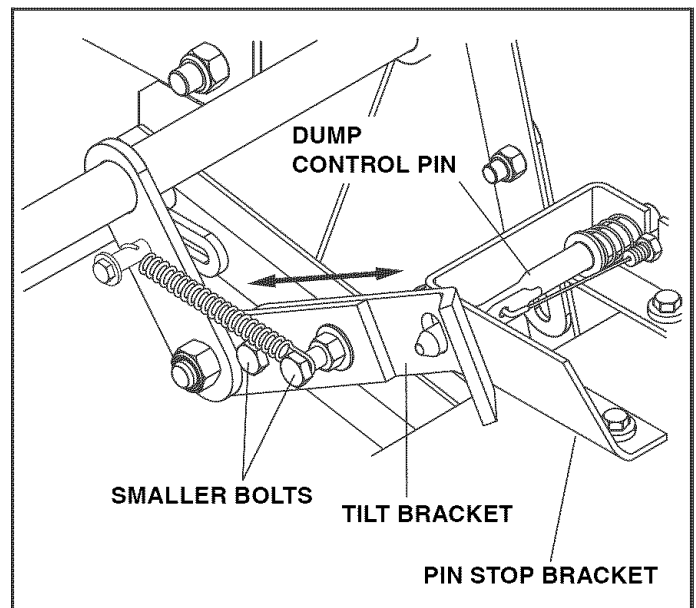

FIGURE 24

**STEP 26: ADJUST LIFT STRAPS
(SEE FIGURE 25)**

- Make sure the nuts and bolts in the lift straps are loose enough to turn by hand. Stand beside the right side of the scoop and **hold the lift handle as far forward as it will go** until you tighten one of the nuts in the lift straps. Let go of the lift handle and tighten the other three nuts in the lift straps.

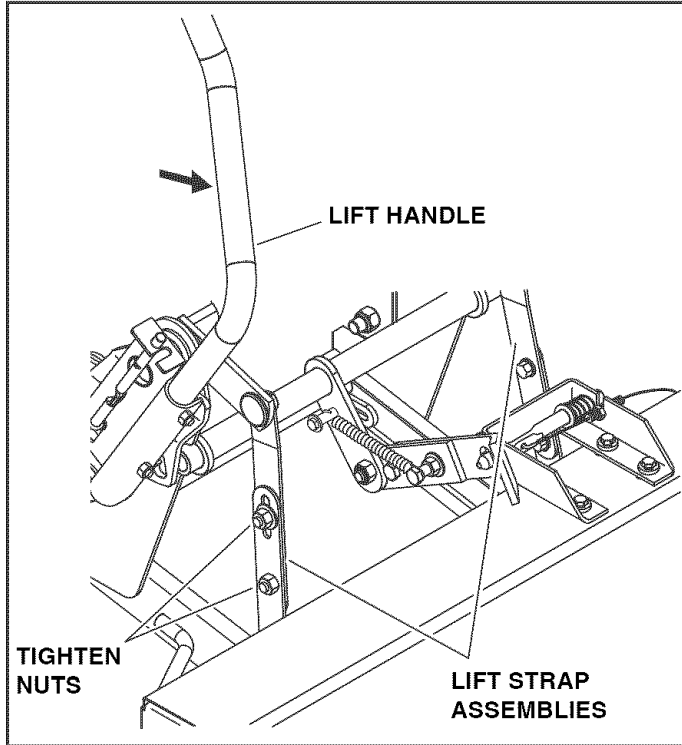

FIGURE 25

**STEP 27: ADJUST TILT STOP BRACKETS
(SEE FIGURE 26)**

- Raise the scoop until it locks in the TRANSPORT position. Push the tilt stop brackets (QQ) on each side of the bucket down against the lift frame arms, and tighten the nuts.

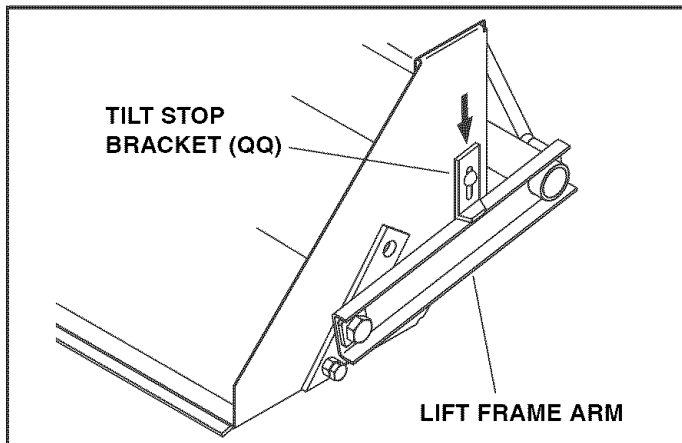

FIGURE 26

**STEP 28: ADJUST SLOTTED STOP BRACKET
(SEE FIGURE 27)**

- Keep the scoop locked in the TRANSPORT position. Push the tilt bracket forward against the dump control pin and then slide the slotted stop bracket forward against the tilt bracket. **SECURELY TIGHTEN** the bolt and nut that fasten the slotted stop bracket.

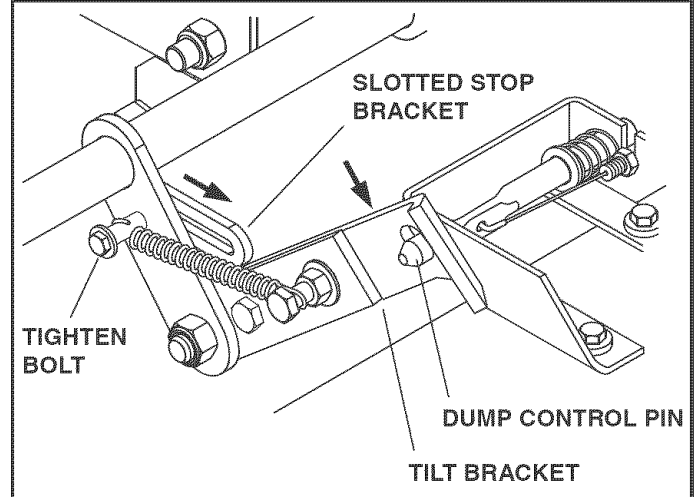

FIGURE 27

STEP 29: CHECK DUMPING OPERATION

- With the scoop in the transport position, squeeze the dump trigger and push down on the dump handle to dump the bucket. Release the dump trigger and lift up on the handle to lock the bucket in the upright position. If the dump control pin does not lock into the tilt bracket, repeat step 28. If it still does not lock into the tilt bracket, repeat steps 25, 26, 27 and 28.

OPERATION

KNOW YOUR FRONT END SCOOP

Read this owner's manual and safety rules before operating your front end scoop.

Compare the illustration below with your front end scoop to familiarize yourself with the various controls and their locations.

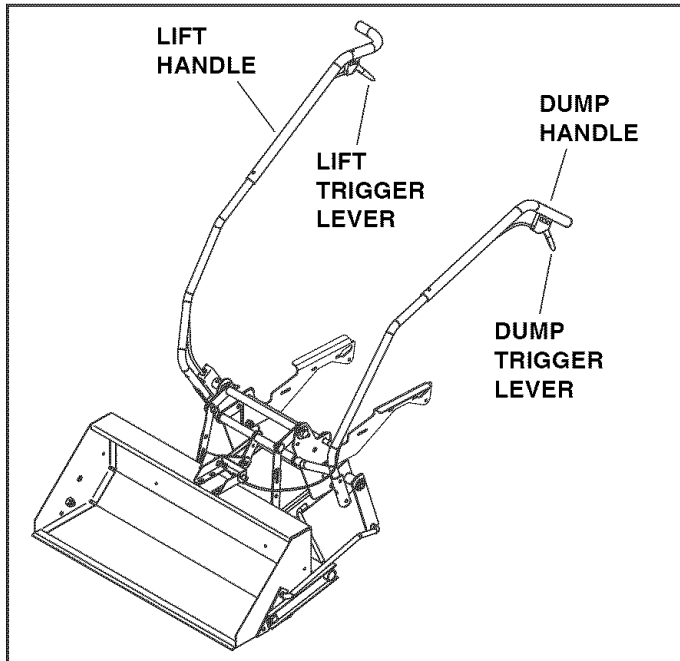

DUMP TRIGGER LEVER Press to release the dump pin.

DUMP HANDLE Press down to dump the bucket.

LIFT TRIGGER LEVER Press to release the index pin.

LIFT HANDLE Press down to lift the bucket assembly.

HOW TO USE YOUR SCOOP

DO NOT EXCEED 200 LB. CAPACITY OF BUCKET

One cubic foot of dirt weighs approximately 80 lbs.

One cubic foot of dry sand or gravel weighs approximately 100 lbs.



CAUTION: Vehicle braking and stability may be affected with the addition of an accessory or an attachment. Be aware of changing conditions on slopes.

- Refer to the vehicle owner's manual for instructions on safe operation on slopes.
- Use the slope guide provided on page 23 of this manual to determine whether slope angle is too steep for safe operation.

- Always test to make sure your vehicle has adequate power and braking capabilities whenever hauling a substantial amount of weight in your front end scoop. Use extra caution when operating on slopes.
- For best handling and traction, distribute the weight of the load evenly in the bucket.



CAUTION: Never ram the scoop into material at high speeds.

- Keep the lift handle locked in the raised position when tilting the scoop bucket forward to dump.
- The lift handle must be locked in the raised position to allow the dump handle to lock the scoop bucket back in the upright position after dumping.
- Do not scrape or push material with the scoop bucket while it is tilted forward.
- Add wheel weights for improved traction when using the scoop.
- To dump material from the bucket, squeeze the dump trigger and push the dump tube handle down. Release the trigger before returning the bucket to the upright position.
- To lower the bucket, squeeze the lift trigger and then lift up on the lift handle. If the trigger is hard to depress, you may need to push down on the lift handle while squeezing, and then lift up. Release the trigger before returning the bucket to the raised position.
- Do not exceed mowing speed (3 mph) when the front end scoop is attached to the tractor.



CAUTION: To avoid possible injury, make sure that no one is near the bucket before dumping the bucket.



CAUTION: Always lower the scoop bucket to the ground before leaving the tractor.

MAINTENANCE

CUSTOMER RESPONSIBILITIES

- Read and follow the maintenance schedule and the maintenance procedures listed in this section.

| MAINTENANCE SCHEDULE Fill in dates as you complete regular service. | Service Dates | | | | | | | | | | | |
|---|-----------------|----------------|--------------|----------------|--|--|--|--|--|--|--|--|
| | Before each use | After each use | Every season | Before storage | | | | | | | | |
| Check for loose fasteners | X | | | | | | | | | | | |
| Cleaning | | X | | | | | | | | | | |
| Lubrication | | | X | | | | | | | | | |

CHECK FOR LOOSE FASTENERS

- Before each use make a thorough visual check of the front end scoop for any bolts and nuts which may have loosened. Retighten any loose bolts and nuts.

CLEANING

- After each use, clean off any dirt and debris from the scoop bucket lift frame.
- Before storing at the end of each season, rinse off the scoop bucket and scoop lift frame. Allow to dry thoroughly. Paint any exposed metal surfaces to protect from rust.
- Store in a clean, dry area.

LUBRICATION

- Lightly oil all pivot points on the scoop lift mechanism.
- Lightly oil the surface on the scoop bucket where the attachment lift frame pivots.
- Apply a good grade of spray lubricant to the trigger assemblies on the lift handle and dump handle.

TROUBLESHOOTING

| PROBLEM | CAUSE | CORRECTION |
|--|---|--|
| Scoop won't lock into raised/transport position. | <ol style="list-style-type: none"> 1. Index rod is jamming. 2. Frame is hitting tilt stop brackets. | <ol style="list-style-type: none"> 1. Apply grease to the bottom slot in the lift bracket, where the index rod slides 2. Adjust the tilt stop brackets as instructed on page 16. |
| Scoop bucket won't lock into level position after dumping. | <ol style="list-style-type: none"> 1. Dump control pin does not align with the tilt bracket. | <ol style="list-style-type: none"> 1. Adjust the tilt bracket and lift straps as instructed on page 16. 2. Adjust the slotted stop bracket as instructed on page 16. |
| Lift handle trigger won't release scoop from the transport position. | <ol style="list-style-type: none"> 1. Index rod is jamming. 2. Lift cable is not adjusted properly. | <ol style="list-style-type: none"> 1. Apply grease to the bottom slot in the lift bracket, where the index rod slides. 2. Adjust cable nuts as instructed on page 10. |
| Dump handle trigger won't release bucket to dump. | <ol style="list-style-type: none"> 1. Dump control cable is not adjusted properly. 2. Latch mechanism is not adjusted properly. | <ol style="list-style-type: none"> 1. Adjust parts as instructed for figure 15 on page 11. 2. Adjust parts as instructed for figure 16 on page 12. |
| Bucket is becoming more difficult to tilt up or down. | <ol style="list-style-type: none"> 1. Debris is lodged between bucket assembly and lift frame. | <ol style="list-style-type: none"> 1. Remove all debris from between the bucket assembly and the lift frame. |

PARTS

REPAIR PARTS FOR MODEL 486.248472

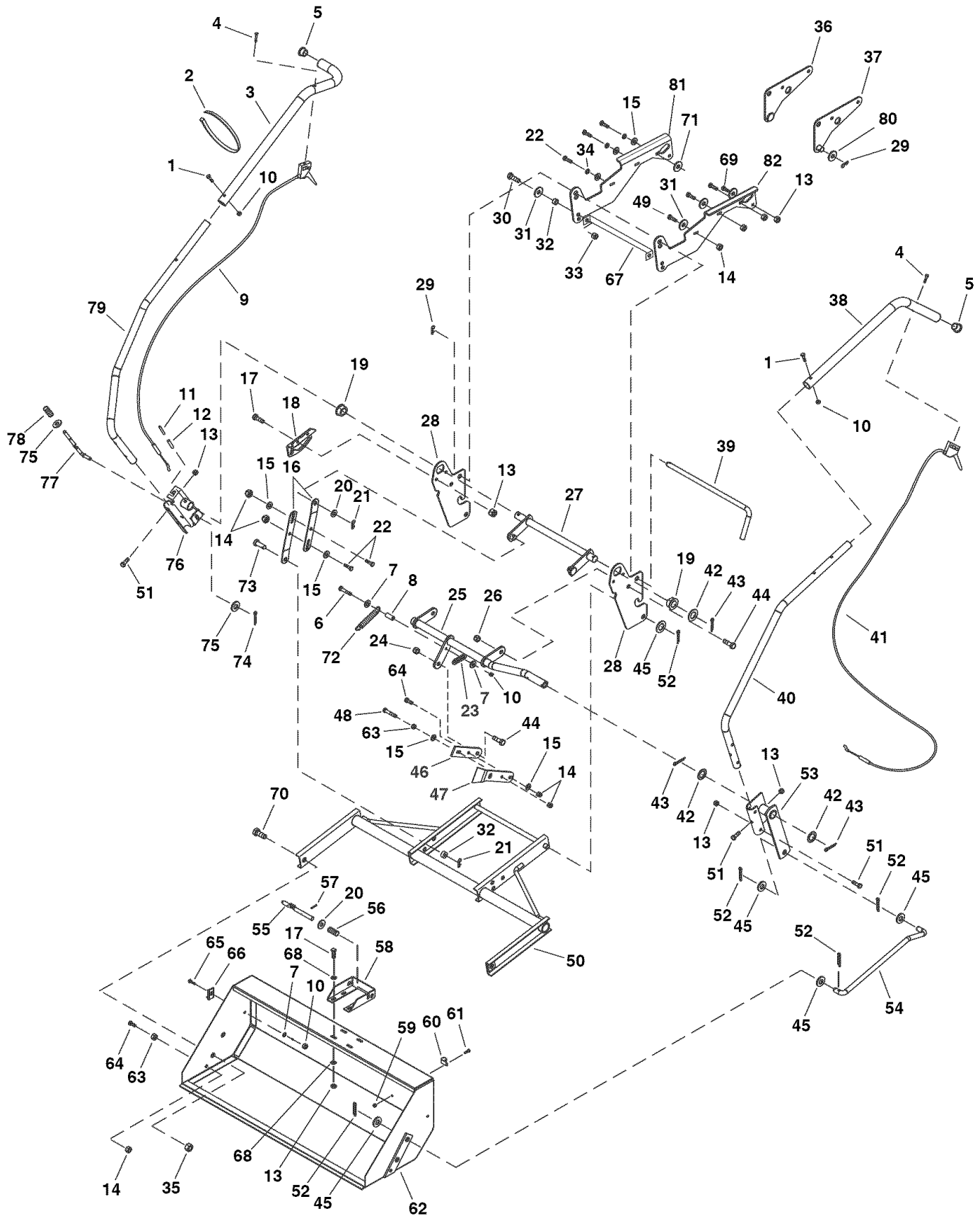

REPAIR PARTS FOR MODEL 486.248472

| REF NO. | PART NO. | QTY | DESCRIPTION | REF NO. | PART NO. | QTY | DESCRIPTION |
|---------|-----------|-----|-------------------------------------|---------|-----------|-----|--|
| 1 | 1509-69 | 2 | Hex Bolt, 1/4-20 x 1-3/4" (Grade 5) | 43 | 43093 | 3 | Cotter Pin, 1/8" x 1-1/2" |
| 2 | 726-0178 | 6 | Cable Tie | 44 | 710-0865 | 3 | Hex Bolt, 1/2-13 x 1" (Grade 5) |
| 3 | 49265 | 1 | Lift Handle Extension | 45 | R19212016 | 6 | Flat Washer, 5/8" x 1-1/4" x 16 Ga. |
| 4 | 49266 | 2 | Oval Screw, 10-24 x 1-1/2" | 46 | 25852 | 1 | Tilt Bracket Extension Strap |
| 5 | 47674 | 2 | Plastic Plug, 1-1/4" O.D. Tube | 47 | 25851 | 1 | Tilt Bracket |
| 6 | 46699 | 1 | Hex Bolt, 1/4-20 x 2" | 48 | HA6441 | 1 | Hex Bolt, 3/8-16 x 2" (Grade 5) |
| 7 | 47135 | 4 | Washer, .28" x .875" x .063" | 49 | 43350 | 6 | Bolt, Carriage 3/8-16 x 1" (Grade 5) |
| 8 | 46053 | 1 | Spacer, .28" x .50" x .95" L | 50 | 64963 | 1 | Lift Frame Assembly |
| 9 | 49912 | 1 | Cable, Lift | 51 | 43084 | 5 | Hex Bolt, 5/16-18 x 1-3/4" (Grade 5) |
| 10 | 47189 | 5 | Nylock Nut, 1/4" | 52 | 43010 | 6 | Cotter Pin, 1/8" x 1-1/4" |
| 11 | 47369 | 1 | Roll Pin, 3/16" x 1-3/4" | 53 | 64968 | 1 | Dump Pivot Bracket |
| 12 | 47368 | 1 | Roll Pin, 5/16" x 1-3/4" | 54 | 49273 | 1 | Dump Control Rod |
| 13 | 47810 | 14 | Nylock Nut, 5/16-18 | 55 | 49268 | 1 | Dump Control Pin |
| 14 | HA21362 | 14 | Nylock Nut, 3/8-16 | 56 | 48905 | 1 | Compression Spring |
| 15 | 43070 | 12 | Flat Washer, 3/8" | 57 | 46055 | 1 | Spring Pin, 1/8" x 1" |
| 16 | 25350 | 4 | Lift Strap | 58 | 25335 | 1 | Pin Stop Bracket |
| 17 | 43063 | 6 | Hex Bolt, 5/16-18 x 1" (Grade 5) | 59 | 47171 | 1 | Nylock Nut, #10-32 |
| 18 | 25343 | 1 | Lift Bracket | 60 | HA23761 | 1 | Hose Clamp |
| 19 | 741-0192 | 2 | Flange Bearing with Flats | 61 | 43346 | 1 | Truss-Head Bolt #10-32 x 5/8" |
| 20 | R19171616 | 4 | Flat Washer, 1/2" x 1" (Small) | 62 | 64962 | 1 | Bucket Assembly |
| 21 | 43055 | 4 | Hairpin Cotter, 3/32" x 1.8" | 63 | 43015 | 3 | Hex Nut, 3/8-16 |
| 22 | 43001 | 10 | Hex Bolt, 3/8-16 x 1" (Grade 5) | 64 | 43087 | 3 | Hex Bolt, 3/8-16 x 1-1/4" (Grade 5) |
| 23 | 25773 | 1 | Slotted Stop Bracket | 65 | 44950 | 2 | Carriage Bolt, 1/4-20 x 3/4" (Grade 5) |
| 24 | 43262 | 1 | Hex Lock Nut, 1/2-13 | 66 | 25331 | 2 | Tilt Stop Bracket |
| 25 | 64964 | 1 | Tilt Anchor Assembly | 67 | 25722 | 1 | Frame Brace |
| 26 | 48115 | 2 | Nylock Jam Nut, 1/2-13 | 68 | 43081 | 8 | Flat Washer, 5/16" |
| 27 | 63675 | 1 | Lift Arm Assembly | 69 | 44326 | 2 | Carriage Bolt, 5/16" x 1" (Grade 5) |
| 28 | 25510 | 2 | Mounting Bracket | 70 | 710-0367 | 2 | Hex Bolt, 5/8-11 x 1-1/2" (Grade 5) |
| 29 | 43343 | 3 | Hairpin Cotter, 3/32" x 2-5/16" | 71 | 736-0235 | 2 | Washer, .375" x 1.26" x .172" |
| 30 | R74780828 | 2 | Hex Bolt 1/2-13 x 1-3/4" (Grade 5) | 72 | 43000 | 1 | Extension Spring |
| 31 | R19172410 | 8 | Flat Washer, 1/2" x 1-1/2" (Large) | 73 | 44062 | 2 | Clevis Pin, 1/2" x 1" |
| 32 | 24817 | 4 | Spacer, 0.52" x 0.75" x 0.5" | 74 | 142 | 1 | Cotter Pin, 1/8" x 3/4" |
| 33 | 712-3083 | 2 | Nylock Nut, 1/2-13 | 75 | R19131316 | 2 | Flat Washer, 3/8" x 13/16" x 1/16" |
| 34 | 43003 | 6 | Lock Washer, 3/8" | 76 | 63773 | 1 | Index Bracket Assembly |
| 35 | 712-0261 | 2 | Nylock Nut, 5/8-11 | 77 | 48049 | 1 | Index Rod |
| 36 | 63568 | 1 | Right (Short) Side Plate | 78 | 732-0306 | 1 | Spring, Compression |
| 37 | 63569 | 1 | Left (Short) Side Plate | 79 | 49264 | 1 | Lift Handle Tube |
| 38 | 49270 | 1 | Dump Handle Tube Extension | 80 | 43009 | 2 | Flat Washer, 3/4" |
| 39 | 47066 | 1 | Attachment Rod | 81 | 25562 | 1 | Right (Long) Side Plate |
| 40 | 49271 | 1 | Dump Handle Tube | 82 | 25563 | 1 | Left (Long) Side Plate |
| 41 | 40173 | 1 | Dump Control Cable | | 48205 | 1 | Owner's Manual |
| 42 | 43601 | 3 | Washer, 1.59" x 1.032" x 0.60" | | | | |

* Purchase Common Hardware Locally

NOTES

SUGGESTED GUIDE FOR SIGHTING SLOPES FOR SAFE OPERATION OF TRACTOR WITH ATTACHMENT

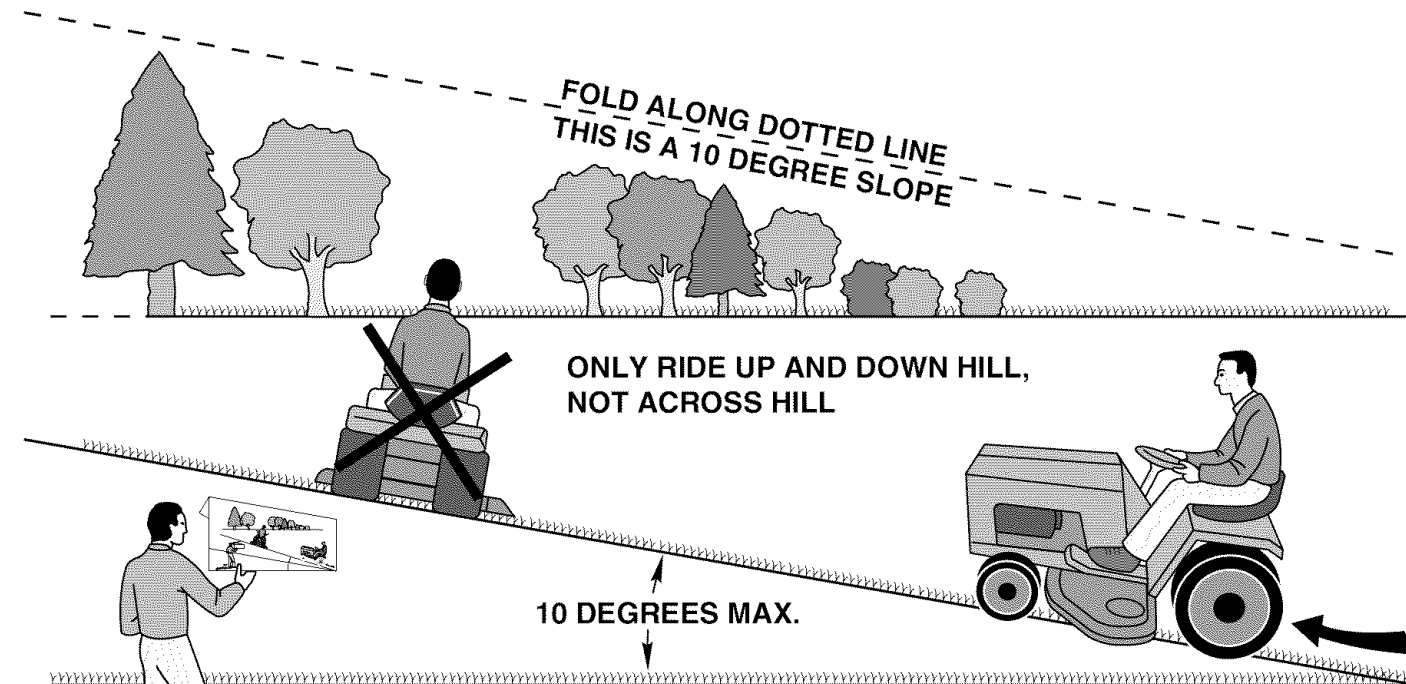

WARNING: To avoid serious injury, operate your tractor up and down the face of slopes, never across the face. Do not operate on slopes greater than 10 degrees. Make turns gradually to prevent tipping or loss of control. Exercise extreme caution when changing direction on slopes. Braking may be affected by tractor attachment. Reduce speed on slopes.

1. Fold this page along dotted line indicated above.
2. Hold page before you so that its left edge is vertically parallel to a tree trunk or other upright structure.
3. Sight across the fold in the direction of hill slope you want to measure.
4. Compare the angle of the fold with the slope of the hill.

Get it fixed, at your home or ours!

Your Home

For repair – **in your home** – of **all** major brand appliances, lawn and garden equipment, or heating and cooling systems, **no matter who made it, no matter who sold it!**

For the replacement parts, accessories and owner's manuals that you need to do-it-yourself.

For Sears professional installation of home appliances and items like garage door openers and water heaters.

1-800-4-MY-HOME® (1-800-469-4663)

Call anytime, day or night (U.S.A. and Canada)

www.sears.com www.sears.ca

Our Home

For repair of carry-in items like vacuums, lawn equipment, and electronics, call or go on-line for the location of your nearest

Sears Parts & Repair Center.

1-800-488-1222

Call anytime, day or night (U.S.A. only)

www.sears.com

To purchase a protection agreement (U.S.A.) or maintenance agreement (Canada) on a product serviced by Sears:

1-800-827-6655 (U.S.A.)

1-800-361-6665 (Canada)

Para pedir servicio de reparación a domicilio, y para ordenar piezas:

1-888-SU-HOGAR®

(1-888-784-6427)

Au Canada pour service en français:

1-800-LE-FOYER^{MC}

(1-800-533-6937)

www.sears.ca

The Sears logo is displayed in a large, bold, black serif font. The word "Sears" is written in a classic, slightly stylized typeface. Below the letters, there is a thin, curved line that underlines the text, starting under the 'S' and ending under the 's'.