

WEIDER®

1120

Model No. WESY19540

Serial No. _____

Write the serial number in the space above for future reference.

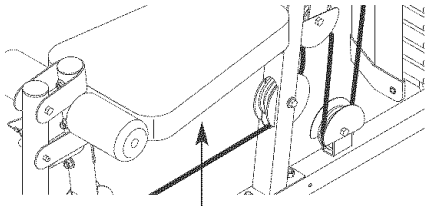

Serial Number Decal (Under Seat)

QUESTIONS?

As a manufacturer, we are committed to providing complete customer satisfaction. If you have questions, or if there are missing or damaged parts, we will guarantee complete satisfaction through direct assistance from our factory.

TO AVOID DELAYS, PLEASE CALL DIRECT TO OUR TOLL-FREE CUSTOMER HOT LINE. The trained technicians on our customer hot line will provide immediate assistance, free of charge.

CUSTOMER HOT LINE:

1-877-992-5999

Mon.–Fri., 6 a.m.–6 p.m. MST

⚠ CAUTION

Read all precautions and instructions in this manual before using this equipment. Save this manual for future reference.

USER'S MANUAL

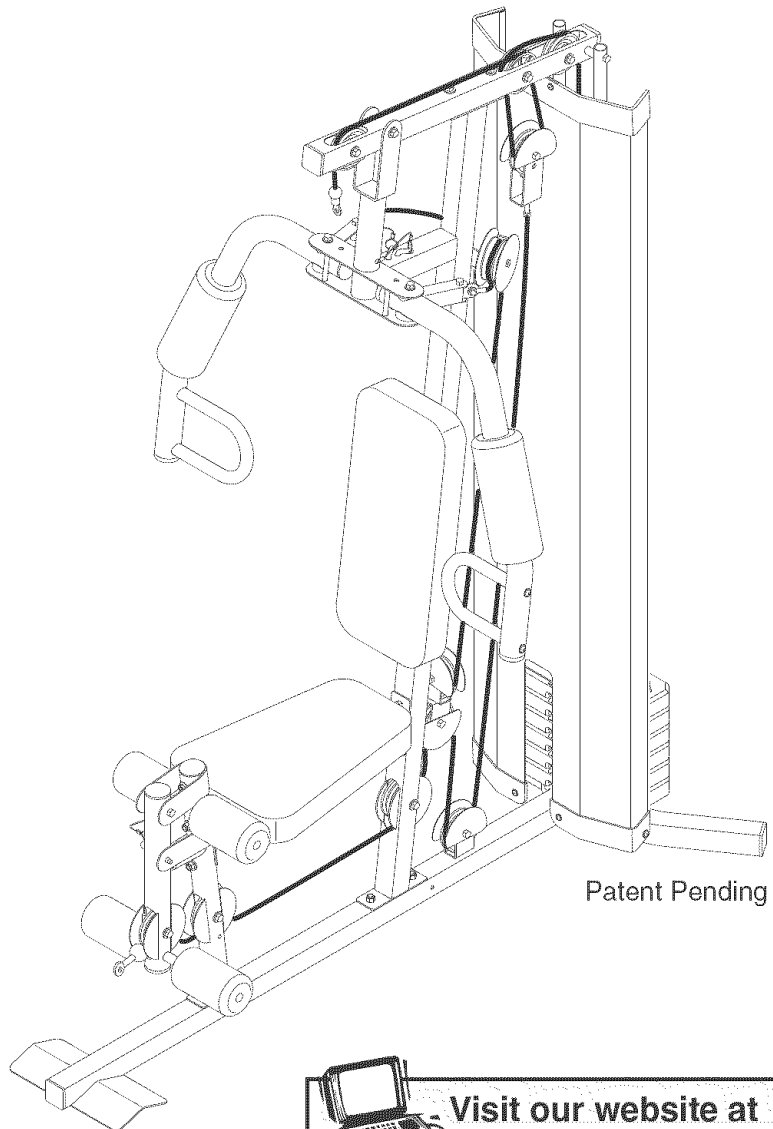

Visit our website at

www.weiderfitness.com

new products, prizes,
fitness tips, and much more!

TABLE OF CONTENTS

WARNING DECAL PLACEMENT	2
IMPORTANT PRECAUTIONS	3
BEFORE YOU BEGIN	4
ASSEMBLY	5
ADJUSTMENTS	17
WEIGHT RESISTANCE CHART	19
CABLE DIAGRAMS	20
MAINTENANCE	21
EXERCISE GUIDELINES	22
ORDERING REPLACEMENT PARTS	Back Cover
LIMITED WARRANTY	Back Cover

Note: A PART IDENTIFICATION CHART and a PART LIST/EXPLODED DRAWING are attached in the center of this manual. Remove the PART IDENTIFICATION CHART and PART LIST/EXPLODED DRAWING before beginning assembly.

WARNING DECAL PLACEMENT

The decals shown here have been placed on the weight system. If a decal is missing or illegible, please call our Customer Service Department toll-free at 1-877-992-5999, Monday through Friday, 6 a.m. until 6 p.m. Mountain Time, to order a free replacement decal. Apply the decal in the location shown.

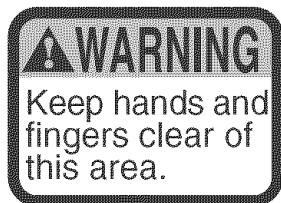

Decal 1

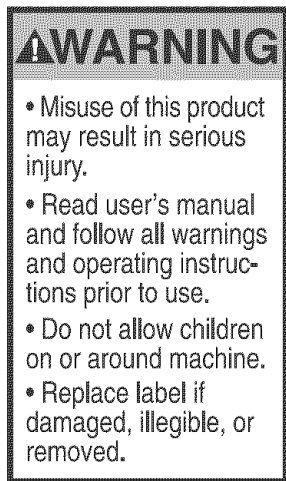

Decal 2

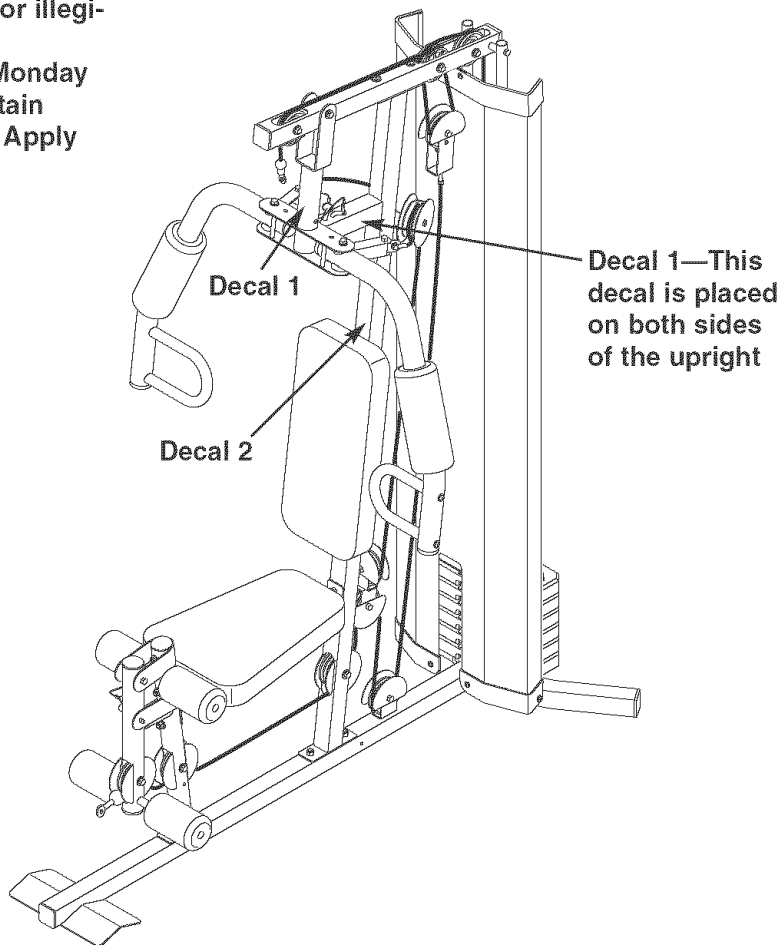

IMPORTANT PRECAUTIONS

⚠ WARNING: To reduce the risk of serious injury, read the following important precautions before using the weight system.

1. Read all instructions in this manual before using the weight system. Use the weight system only as described in this manual.
2. It is the responsibility of the owner to ensure that all users of the weight system are adequately informed of all precautions.
3. The weight system is intended for home use only. Do not use the weight system in any commercial, rental, or institutional setting.
4. Use the weight system only on a level surface. Cover the floor beneath the weight system to protect the floor.
5. Make sure all parts are properly tightened each time the weight system is used. Replace any worn parts immediately.
6. Keep children under 12 and pets away from the weight system at all times.
7. Always wear athletic shoes for foot protection while exercising.
8. Keep hands and feet away from moving parts.
9. The weight system is designed to support a maximum user weight of 300 pounds.
10. Always secure the weight stack with the lock pin and lock after exercising to prevent unauthorized use of the weight system (see **LOCKING THE WEIGHT STACK** on page 18).
11. Make sure that the cables remain on the pulleys at all times. If the cables bind as you are exercising, stop immediately and make sure that the cables are on the pulleys.
12. Always stand on the foot plate when performing an exercise that could cause the weight system to tip.
13. Never release the arms, leg lever, lat bar, or handle strap while weights are raised. The weights will fall with great force.
14. *Always disconnect the lat bar from the weight system when performing an exercise that does not use the lat bar.*
15. If you feel pain or dizziness while exercising, stop immediately and begin cooling down.

⚠ WARNING: Before beginning this or any exercise program, consult your physician. This is especially important for persons over the age of 35 or persons with pre-existing health problems. Read all instructions before using. ICON assumes no responsibility for personal injury or property damage sustained by or through the use of this product.

BEFORE YOU BEGIN

Thank you for selecting the versatile WEIDER® 1120 weight system. The weight system offers a selection of weight stations designed to develop every major muscle group of the body. Whether your goal is to tone your body, build dramatic muscle size and strength, or improve your cardiovascular system, the weight system will help you to achieve the specific results you want.

For your benefit, read this manual carefully before using the weight system. If you have questions after reading this manual, please call our Customer Service

Department toll-free at 1-877-992-5999, Monday through Friday, 6 a.m. until 6 p.m. Mountain Time (excluding holidays). To help us assist you, please note the product model number and serial number before calling. The model number is WESY19540. The serial number can be found on a decal attached to the weight system (see the front cover of this manual).

Before reading further, please review the drawing below and familiarize yourself with the parts that are labeled.

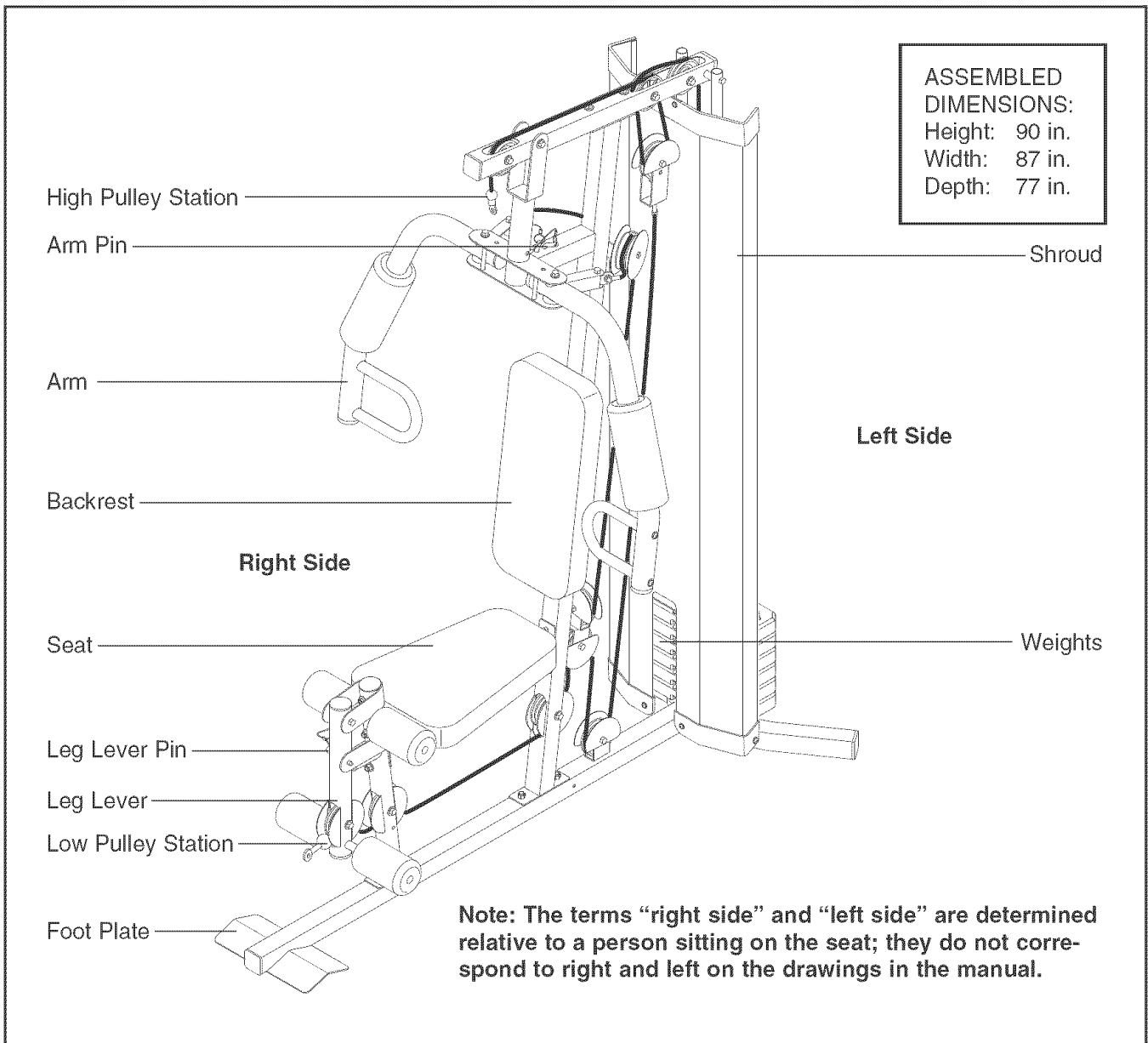

ASSEMBLY

Make Assembly Easier for Yourself

Everything in this manual is designed to ensure that the weight system can be assembled successfully by anyone. **Before beginning assembly, make sure to read the information on this page. This brief introduction will save you much more time than it takes to read it.**

Assembly Requires Two Persons

For your convenience and safety, assemble the weight system with the help of another person.

Set Aside Enough Time

Due to the many features of the weight system, the assembly process will require several hours. By setting aside plenty of time and by deciding to make the task enjoyable, assembly will go smoothly. You may want to assemble the weight system over a couple of evenings.



Select a Location for the Weight System

Because of its weight and size, the weight system should be assembled in the location where it will be used. Make sure that there is enough room to walk around the weight system as you assemble it.

How to Unpack the Box

To make assembly as easy as possible, we have divided the assembly process into four stages. The parts needed for each stage are found in individual bags. **Important: Wait until you begin each stage to open the parts bag for that stage.** Place all parts of the weight system in a cleared area and remove the packing materials. Do not dispose of the packing materials until assembly is completed.

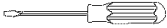
Make sure you have the following tools:

- Two adjustable wrenches 
- One standard screwdriver 
- One phillips screwdriver 
- One rubber mallet 
- You will also need grease or petroleum jelly, a small amount of soapy water, and clear tape or masking tape.

Note: Assembly will be more convenient if you have a socket set, a set of open-end or closed-end wrenches, or a set of ratchet wrenches.

How to Identify Parts

To help you identify the small parts used in assembly, we have included a **PART IDENTIFICATION CHART** in the center of this manual. Place the chart on the floor and use it to easily identify parts during each assembly step. **Note: Some small parts may have been pre-attached. If a part is not in the parts bag, check to see if it has been pre-attached.**

How to Orient Parts

As you assemble the weight system, make sure that all parts are oriented exactly as shown in the drawings.

Tightening Parts

Tighten all parts as you assemble them, unless instructed to do otherwise.

Questions?

If you have questions after reading the assembly instructions, please call our Customer Service Department at 1-877-992-5999.

The Four Stages of the Assembly Process

Frame Assembly—You will begin by assembling the base and the uprights that form the skeleton of the weight system.

Arm Assembly—During this stage you will assemble the arms and the leg lever.

Cable Assembly—During this stage you will attach the cables and pulleys that connect the arms to the weights.

Seat Assembly—During the final stage you will assemble the seats and the backrests.

Frame Assembly

1. Before beginning assembly, make sure you understand the information in the box on page 5. Refer to the **PART IDENTIFICATION CHART** in the center of this manual for help identifying small parts.

Insert two M10 x 65mm Carriage Bolts (78) and two M8 x 63mm Carriage Bolts (87) up through the Base (1). **Note: It may be helpful to place a piece of tape over the bolt heads to hold them in place.**

2. Attach the Base (1) and the two Weight Guides (21) to the Stabilizer (2) with two M10 x 67mm Bolts (71), two M10 Washers (57), and two M10 Nylon Locknuts (56). **Make sure the indicated holes in the Weight Guides are nearer the bottom.**

Attach the Upright (3) to the Base (1) with the two M10 x 65mm Carriage Bolts (78) and two M10 Nylon Locknuts (56). **Do not tighten the Locknuts yet.**

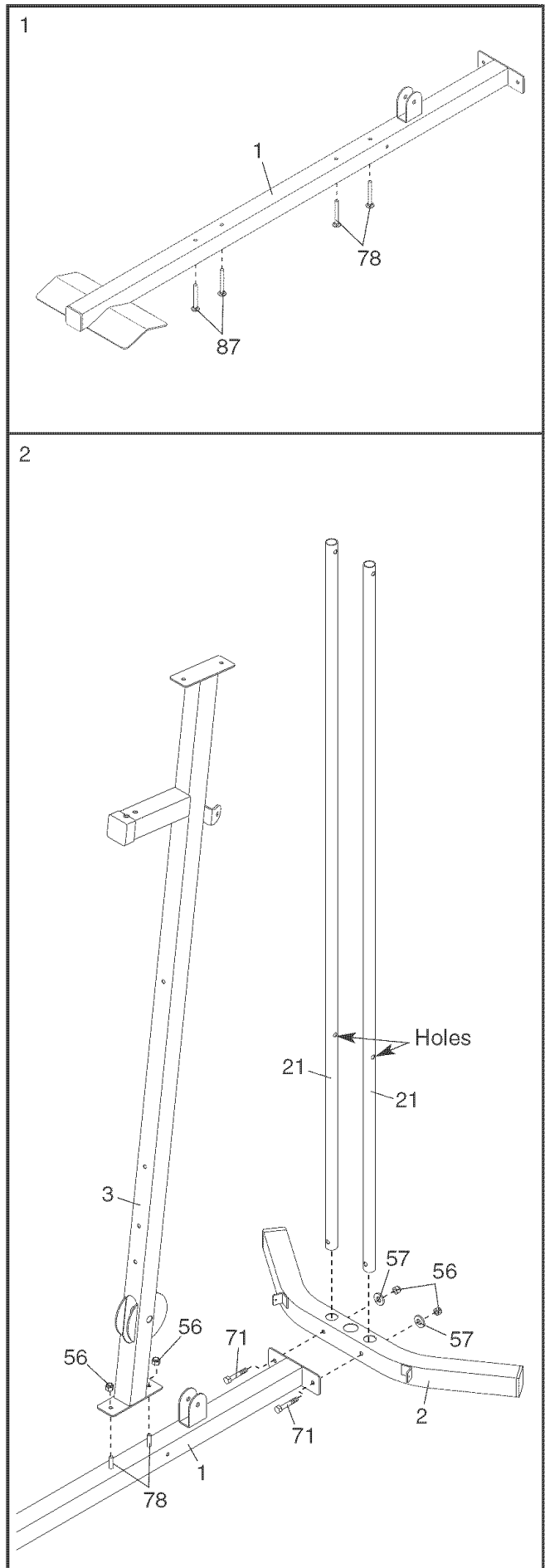

- Attach the Front Leg (7) to the Base (1) with the two M8 x 63mm Carriage Bolts (87) and two M8 Nylon Locknuts (58). **Do not tighten the Locknut yet.**

Attach the Leg Bumper (60) to the Front Leg (7) with an M4 x 20mm Self-tapping Screw (69) and an M4 Washer (33). **Make sure the end of the Bumper is pointing up.**

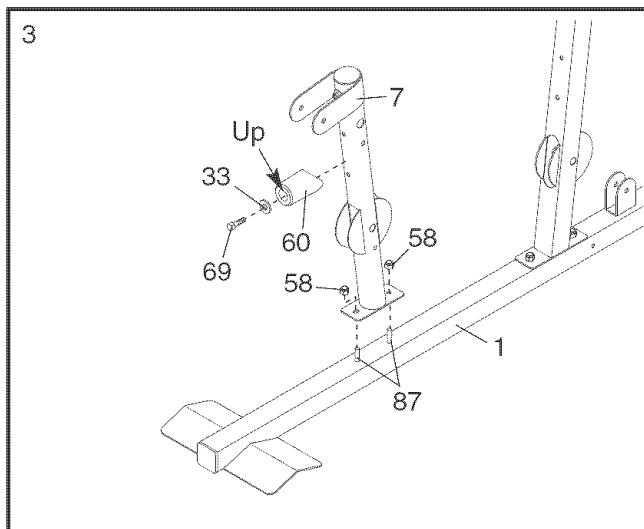

- Attach the Seat Frame (6) to the Upright (3) with two M8 x 65mm Bolts (68), two M8 Washers (59), and two M8 Nylon Locknuts (58). **Do not tighten the Locknuts yet.**

Attach the Seat Frame (6) to the Front Leg (7) in the same manner.

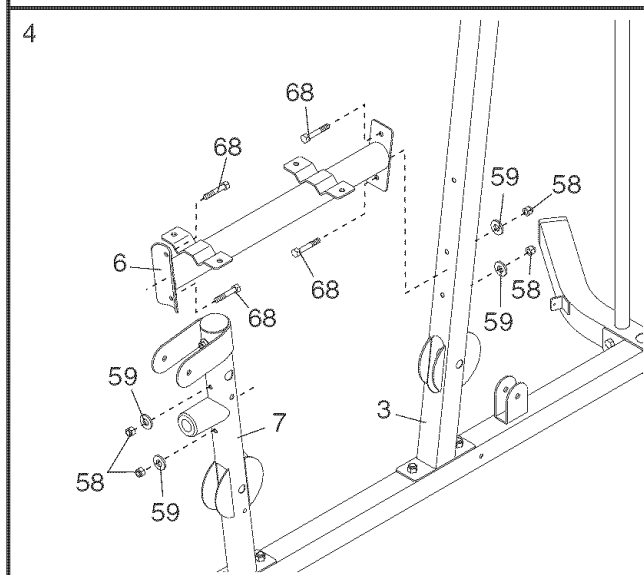

- Slide the two Weight Bumpers (27) onto the Weight Guides (21). Slide the six Weights (22) onto the Weight Guides, with the pin holes on the bottom as shown.

Insert the Weight Tube Bumper (23) into the Weight Tube (24). Insert the Weight Tube into the weight stack. **Make sure the pin on the Weight Tube is oriented as shown.**

Lubricate the indicated holes in the Top Weight (25) with the included grease packet. Slide the Top Weight onto the Weight Guides (21).

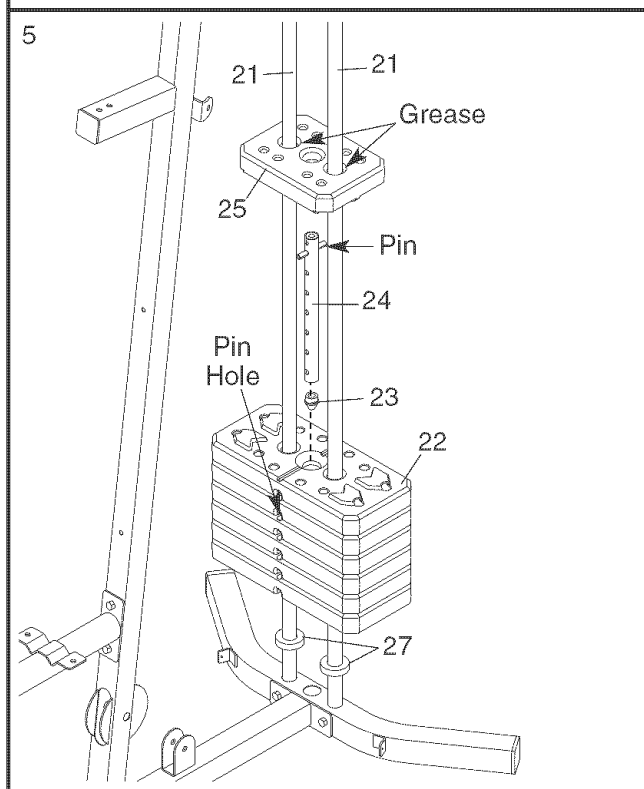

6. Attach the Top Frame (4) to the Upright (3) with two M10 x 67mm Bolts (71), two M10 Washers (57), and two M10 Nylon Locknuts (56). **Do not tighten the Locknuts yet.**

Attach the Top Frame (4) between the Weight Guides (21) with an M10 x 155mm Bolt (74), two M10 Washers (57), two 19mm Spacers (76), and an M10 Nylon Locknut (56). **Do not tighten the Locknuts yet.**

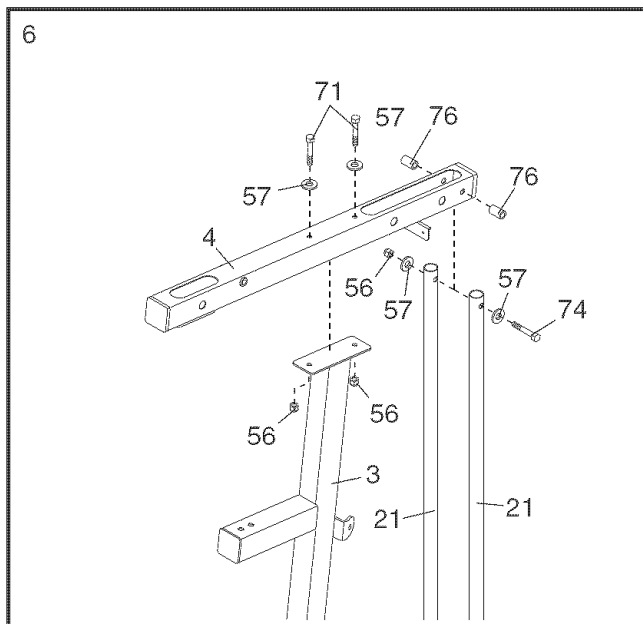

7. Attach the Left Cap (19) and the Right Cap (20) to the bottom of the Shroud (17) with two M5 x 20mm Self-tapping Screws (64) and two M5 Washers (72).

Attach the Top Cap (18) to the top of the Shroud (17) with two M6 x 16mm Screws (62), four M6 Washers (82), and two M6 Locknuts (92).

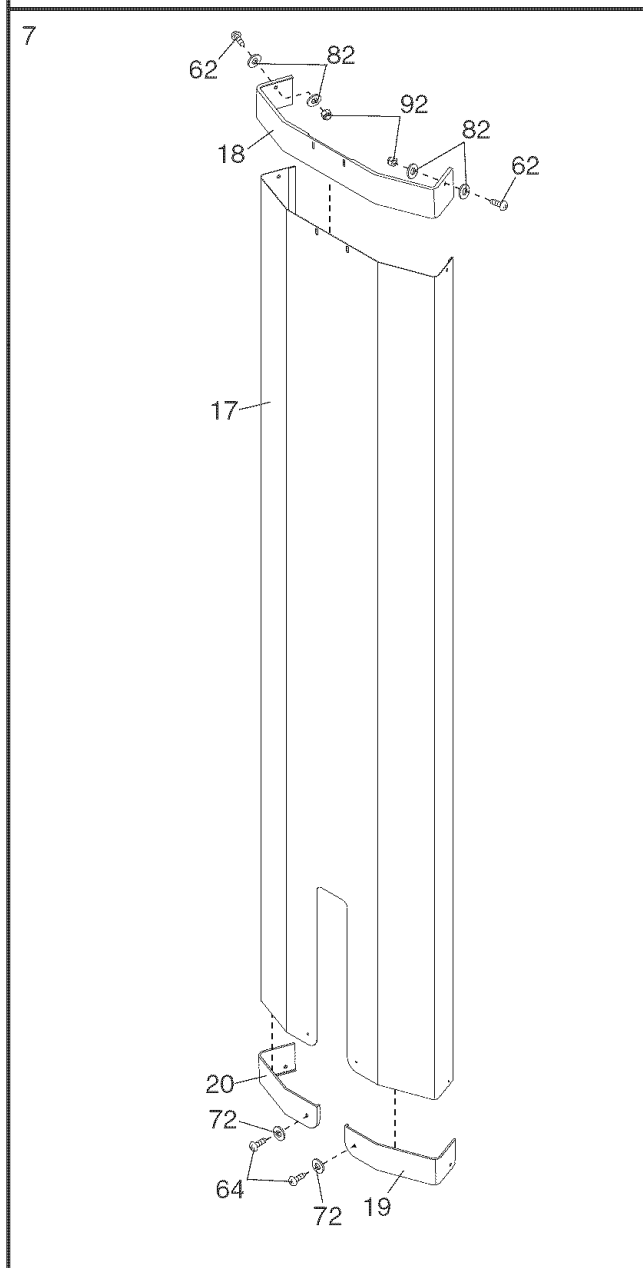

- Attach the Shroud (17) to the Top Frame (4) with two M6 x 16mm Screws (62) and two M6 Washers (82).

Attach the Shroud (17) to the brackets on the Stabilizer (2) with two M6 x 16mm Screws (62) and two M6 Washers (82). **Make sure the brackets are inside the Shroud.**

Tighten the Nylon Locknuts (56, 58) used in steps 2–7.

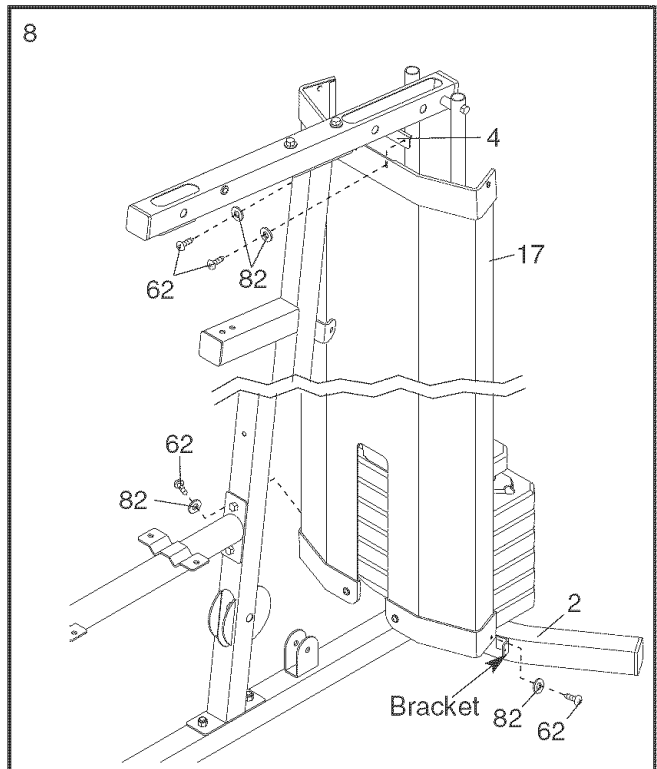

Arm Assembly

- Grease the M10 x 77mm Bolt (79). Orient the Leg Lever (8) as shown. Attach the Leg Lever to the Front Leg (7) with the Bolt and an M10 Nylon Locknut (56). **Do not overtighten the Locknut; the Leg Lever must be able to pivot easily.**

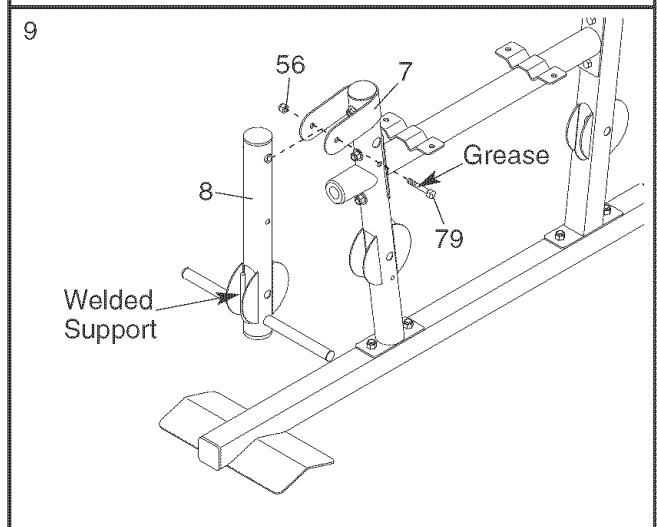

- Grease the M10 x 80mm Bolt (80). Attach the Pivot Frame (5) to the Top Frame (4) with the Bolt and an M10 Nylon Locknut (56). **Do not overtighten the Locknut; the Pivot Frame must be able to pivot easily.**

Attach the two Arm Pins (40) to the Pivot Frame (5) with two M4 x 20mm Self-tapping Screws (69). Insert the Arm Pins into the two holes in the Upright (3).

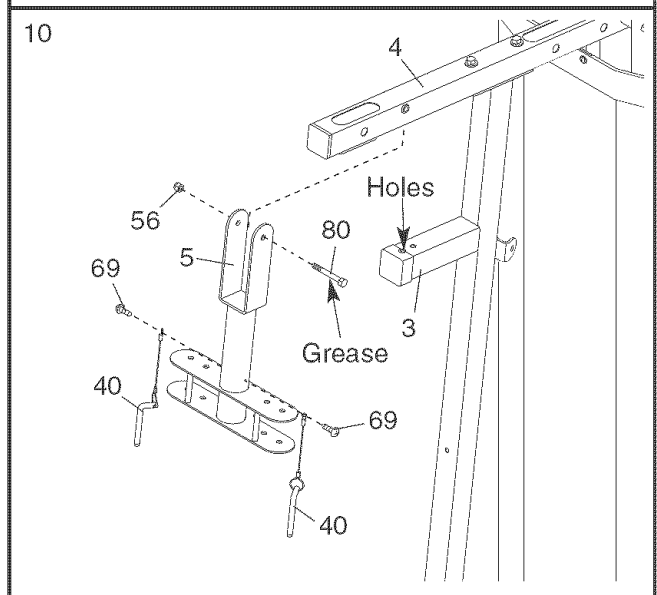

11. Grease an M10 x 51mm Bolt (66). Attach a Cable Pivot (39) to the Left Arm (10) with the Bolt and an M10 Nylon Locknut (56). **Do not overtighten the Locknut; the Cable Pivot must be able to pivot easily.**

Wet the inside of a Large Foam Pad (42) with soapy water. Slide the Large Foam Pad onto the Left Arm (10).

Attach a Handle (11) to the Left Arm (10) with two M10 x 25mm Button Bolts (77) and two M10 Washers (57).

Assemble the Right Arm (9) in the same manner.

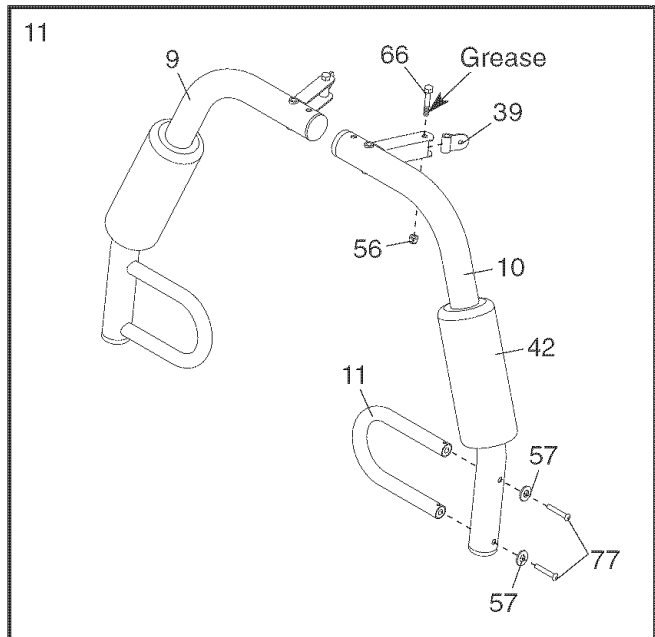

12. Grease an M10 x 85mm Bolt (67) and two Arm Bushings (44). Attach the Right Arm (9) to the Pivot Frame (5) with the Bolt, two M10 Washers (57), the two Arm Bushings, and an M10 Nylon Locknut (56). **Do not overtighten the Locknut; the Arm must be able to pivot easily.**

Attach the Left Arm (10) to the Pivot Frame (5) in the same manner.

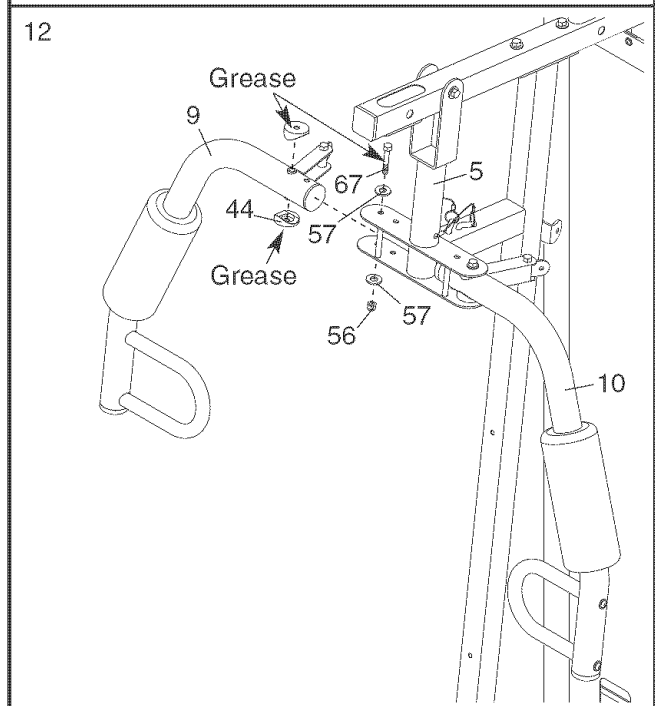

Cable Assembly

13. Refer to the **CABLE DIAGRAMS** on page 20 as you assemble the cables and to identify the cables.

Locate the Arm Cable (54). Grease an M8 x 22mm Shoulder Bolt (65). Attach the Cable to the indicated Cable Pivot (39) with the Bolt and an M8 Nylon Locknut (58).

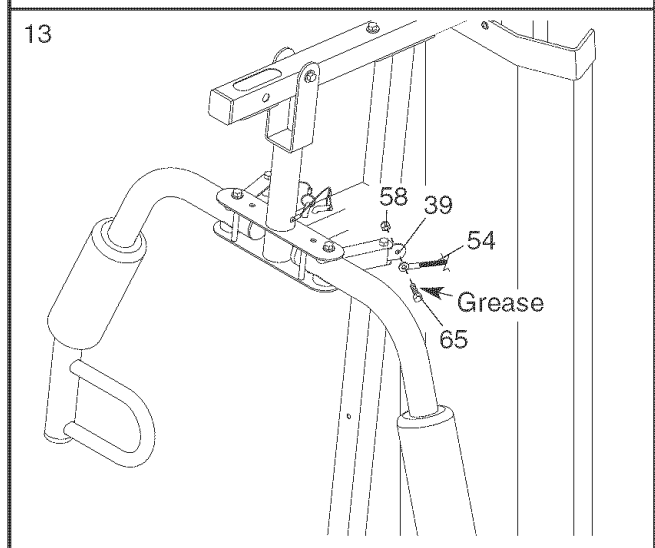

14. Route the Arm Cable (54) over a "V"-pulley (46). Attach the "V"-pulley, a Large Cable Trap (50), two Full Finger Guards (41), and an M10 Washer (57) to the Upright (3) with an M10 x 63mm Bolt (75) and an M10 Nylon Locknut (56). **Make sure the Cable Trap is oriented to hold the Cable in the groove of the "V"-pulley.**

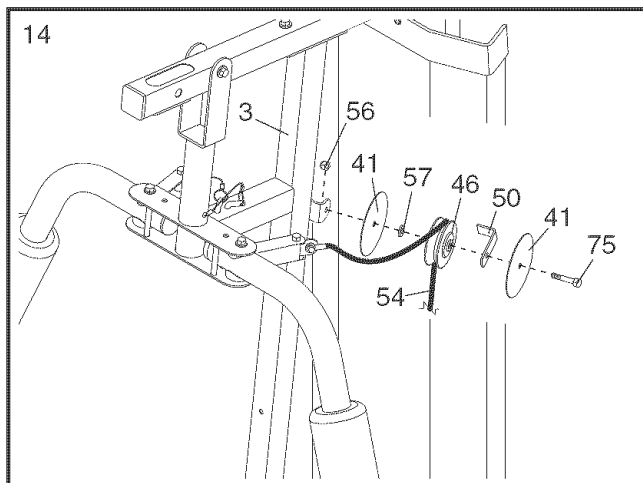

15. Route the Arm Cable (54) under a 90mm Pulley (48). Attach the Pulley and two Half Finger Guards (43) to the Double "U"-Bracket (63) with an M10 x 48mm Bolt (81) and an M10 Nylon Locknut (56). **Make sure the Finger Guards are on the outside of the "U"-bracket as shown.**

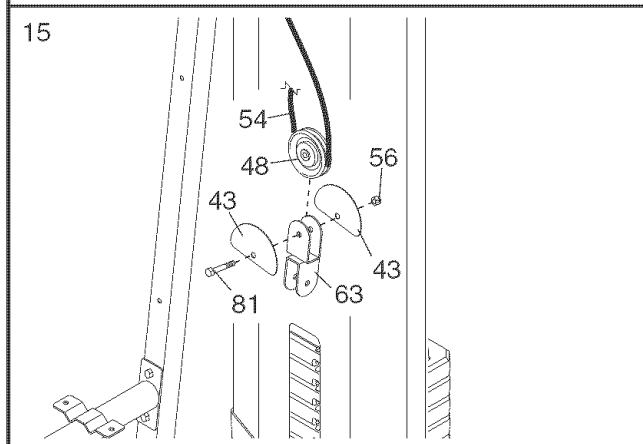

16. Route the Arm Cable (54) over a "V"-pulley (46). Attach the "V"-pulley, a Large Cable Trap (50), two Full Finger Guards (41), and an M10 Washer (57) to the Upright (3) with an M10 x 63mm Bolt (75) and an M10 Nylon Locknut (56). **Make sure the Cable Trap is oriented to hold the Cable in the groove of the "V"-pulley.**

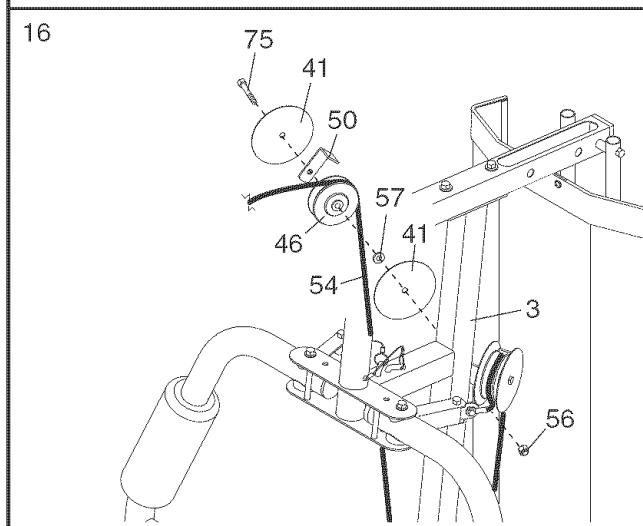

17. Grease an M8 x 22mm Shoulder Bolt (65). Attach the Arm Cable (54) to the indicated Cable Pivot (39) with the Bolt and an M8 Nylon Locknut (58).

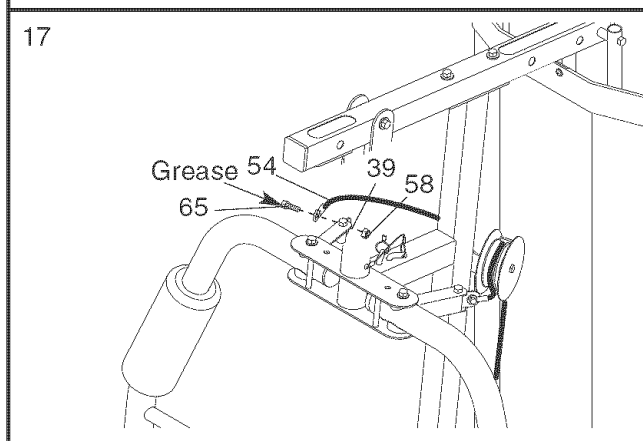

18. **Locate the Low Cable (53).** Route the Cable through the Leg Lever (8) and the Front Leg (7).

Attach a 90mm Pulley (48) inside of the Leg Lever (8), over the Low Cable (53), with an M10 x 67mm Bolt (71), two M10 Washers (57), two 12mm Spacers (52), and an M10 Nylon Locknut (56).

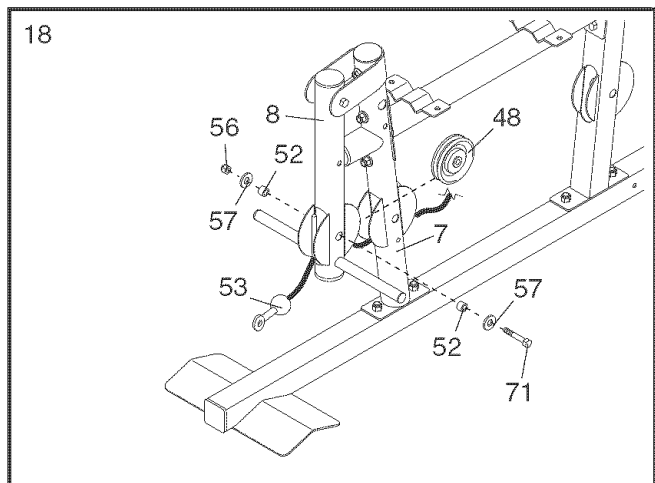

19. Attach a 90mm Pulley (48) inside of the Front Leg (7), over the Low Cable (53), with an M10 x 67mm Bolt (71), two M10 Washers (57), two 12mm Spacers (52), and an M10 Nylon Locknut (56).

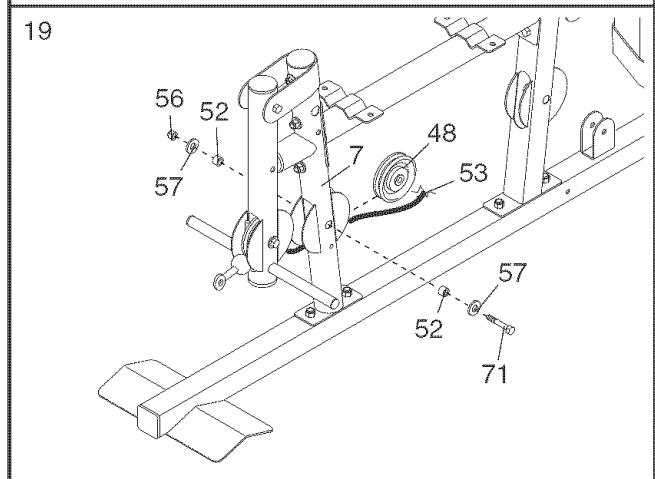

20. Route the Low Cable (53) under a 90mm Pulley (48) and through the Upright (3). Attach the Pulley inside of the upright with an M10 x 67mm Bolt (71), two M10 Washers (57), two 12mm Spacers (52), and an M10 Nylon Locknut (56).

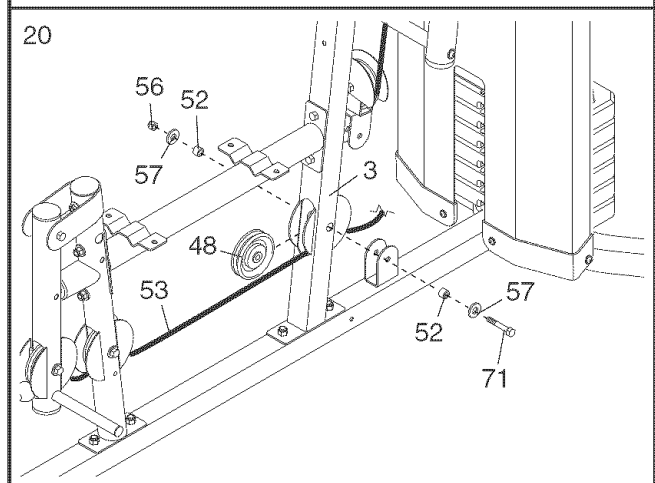

21. Route the Low Cable (53) over a 90mm Pulley (48). Attach the Pulley and two Half Finger Guards (43) to the Double "U"-Bracket (63) with an M10 x 48mm Bolt (81) and an M10 Nylon Locknut (56). **Make sure the Finger Guards are on the outside of the "U"-bracket as shown.**

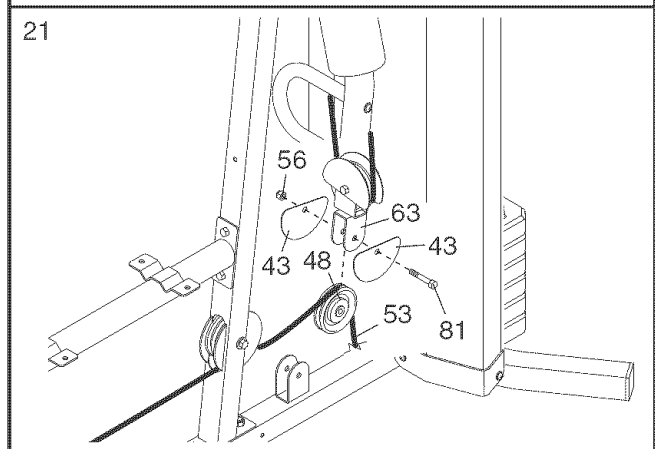

22. Route the Low Cable (53) under a 90mm Pulley (48). Attach the Pulley and two Half Finger Guards (43) to the Base (1) with an M10 x 48mm Bolt (81) and an M10 Nylon Locknut (56). **Make sure the Finger Guards are on the outside of the bracket as shown.**

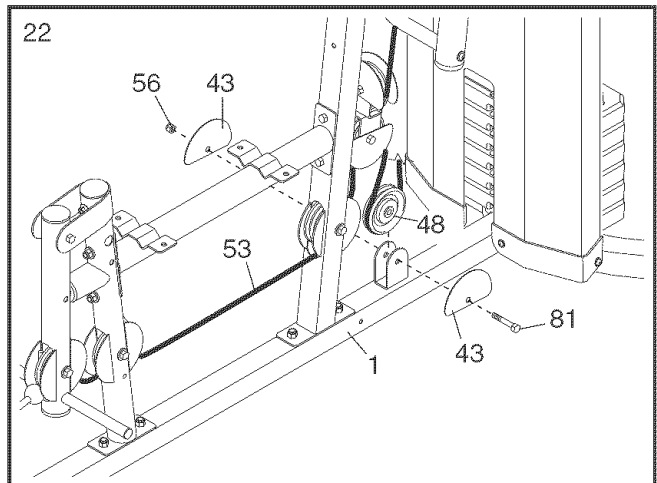

23. Attach the Low Cable (53) to the "U"-bracket (45) with an M8 Washer (59) and an M8 Nylon Locknut (58). **See the inset drawing. Do not overtighten the Nylon Locknut; it should be threaded onto the end of the Cable so only two threads are showing above the nut.**

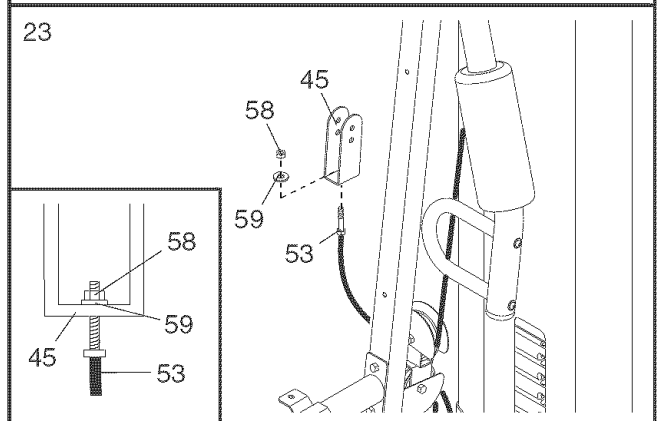

24. **Locate the High Cable (55).** Route the Cable up through the Top Frame (4) and over a 90mm Pulley (48). Attach the Pulley inside of the Top Frame with an M10 x 67mm Bolt (71), two M10 Washers (57), two 12mm Spacers (52), and an M10 Nylon Locknut (56).

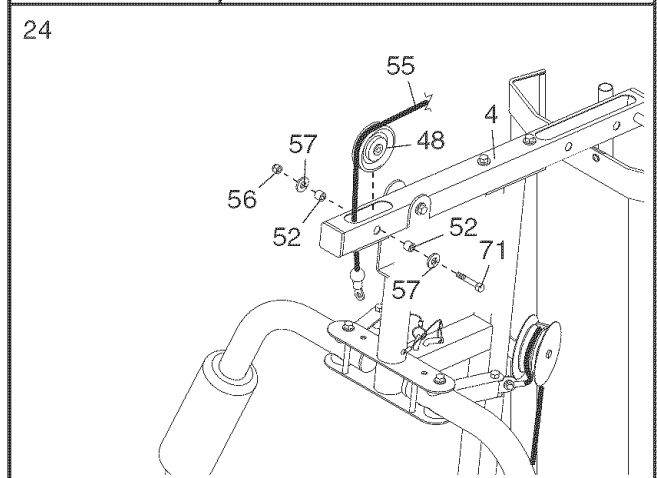

25. Route the High Cable (55) over a 90mm Thin Pulley (47) and down through the Top Frame (4). Attach the Pulley inside of the Top Frame with an M10 x 67mm Bolt (71), an M10 Washer (57), and an 11mm Spacer (49).

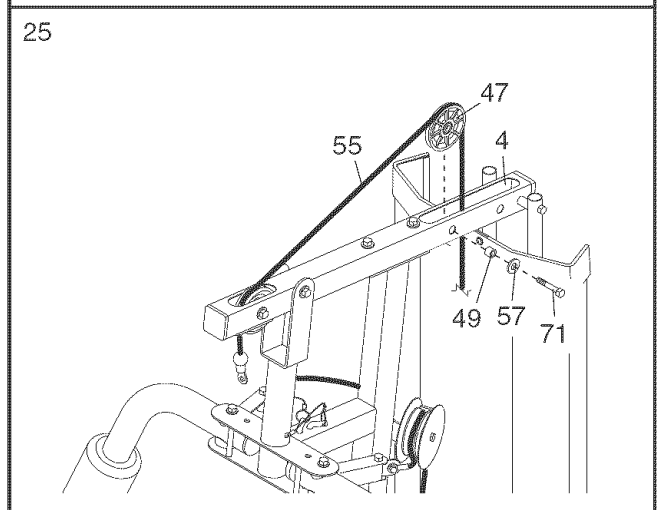

26. Wrap the High Cable (55) under a 90mm Pulley (48). Attach the Pulley, a Cable Trap (51), and two Half Finger Guards (43) at the upper hole in the "U"-bracket (45) with an M10 x 51mm Bolt (66) and an M10 Nylon Locknut.
- Make sure the Cable Trap is oriented to hold the Cable in the groove of the Pulley and that the Finger Guards are on the outside of the "U"-bracket.**

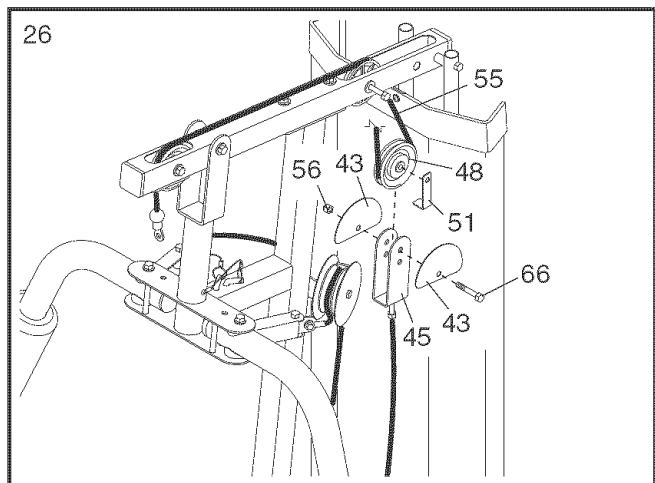

27. Route the High Cable (55) up through the Top Frame (4) and over a 90mm Thin Pulley (47). Attach the Pulley inside of the Top Frame with the M10 x 67mm Bolt (71) used in step 25, an 11mm Spacer (49), an M10 Washer (57), and an M10 Nylon Locknut (56).

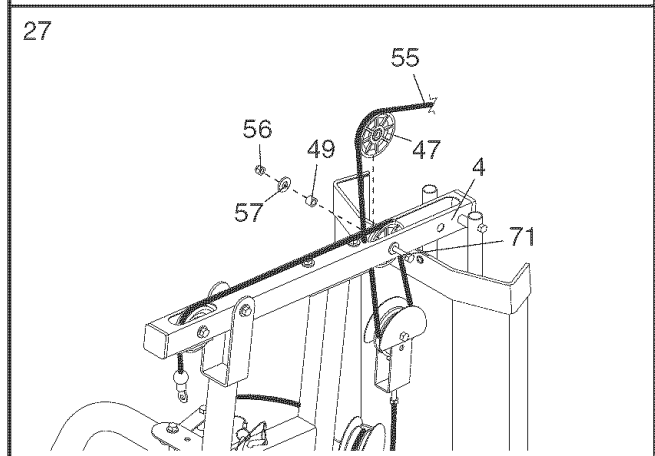

28. Route the High Cable (55) over a 90mm Pulley (48) and down through the Top Frame (4). Attach the Pulley inside of the Top Frame with an M10 x 67mm Bolt (71), two M10 Washers (57), two 12mm Spacers (52), and an M10 Nylon Locknut (56).

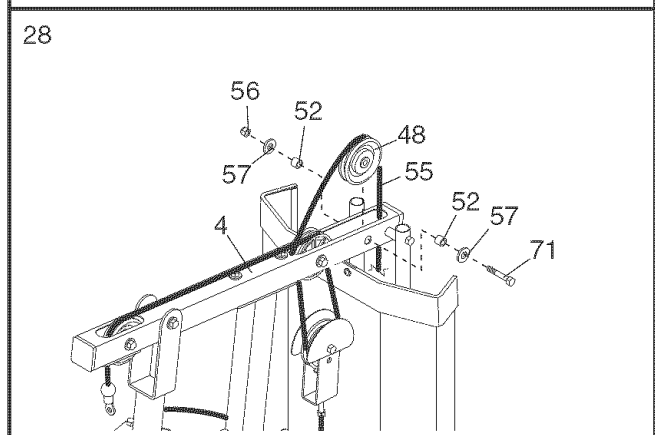

29. **Note: The shroud is shown removed in this step for clarity.**

Thread an M12 Nut (84) all the way onto the High Cable (55). Place a Large Washer (85) on top of the Weight Tube (24).

Tighten the High Cable (55) into the Weight Tube (24) until all the slack is removed from the cables. Tighten the M12 Nut (84) against the Large Washer (85).

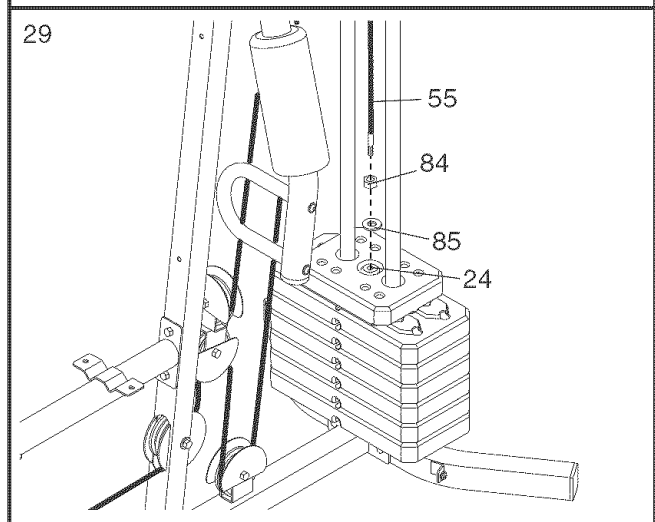

Seat Assembly

30. Attach the Backrest (16) to the Upright (3) with two M6 x 63mm Screws (70) and two M6 Washers (82).

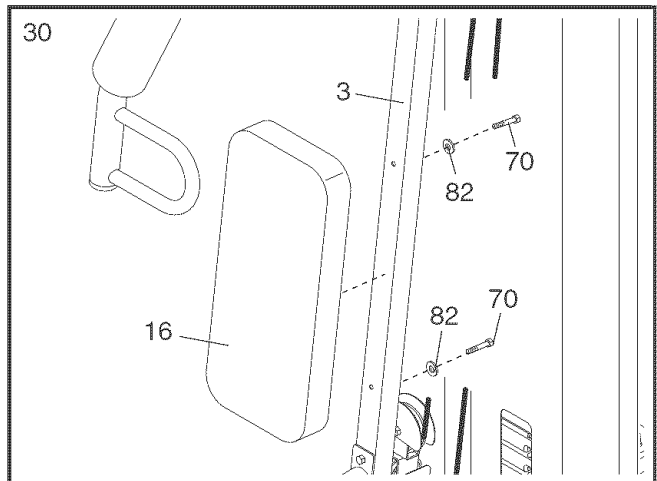

31. Attach the Seat (15) to the Seat Frame (6) with four M6 x 16mm Screws (62), as shown.

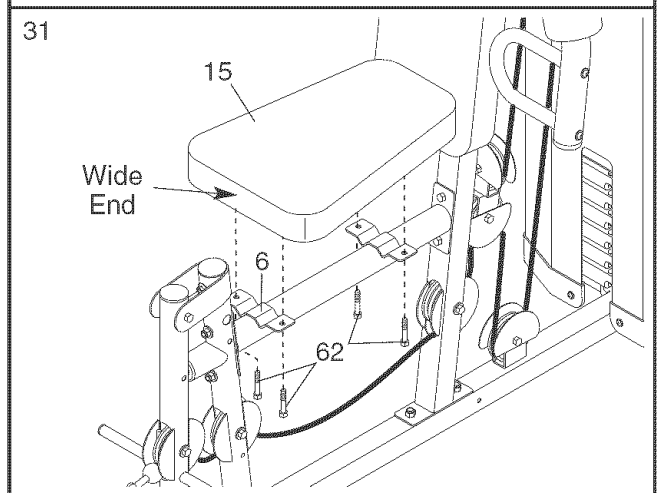

32. Attach the Lock Plate (73) to the Front Leg (7) with an M10 x 70mm Bolt (86), an M10 Washer (57), and an M10 Nylon Locknut (56). **Do not overtighten the Locknut; the Lock Plate must be able to pivot easily.**

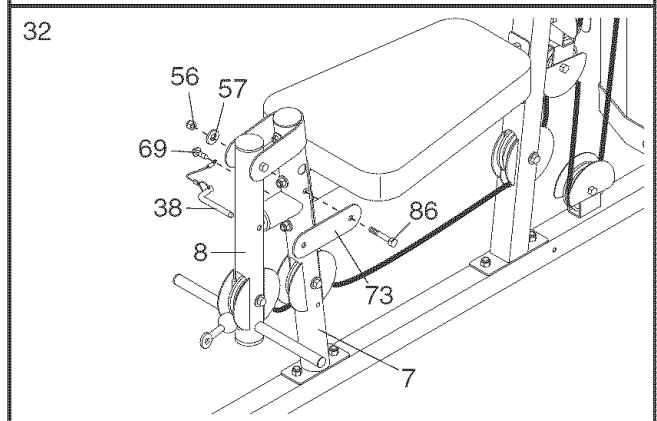

Attach the Leg Lever Pin (38) to the Front Leg (7) with an M4 x 20mm Self-tapping Screw (69). Insert the Leg Lever Pin through the Leg Lever (8) and the Lock Plate (73).

33. Insert the Pad Tube (29) through the Front Leg (7). Slide two Small Foam Pads (28) onto the ends of the Pad Tube.

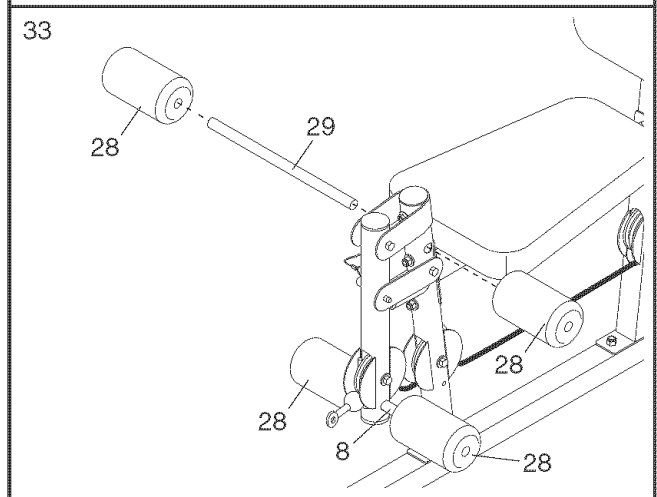

Slide two Small Foam Pads (28) onto the Leg Lever (8).

34. Attach the Curl Pad (14) to the Curl Post (13) with two M6 x 16mm Screws (62).

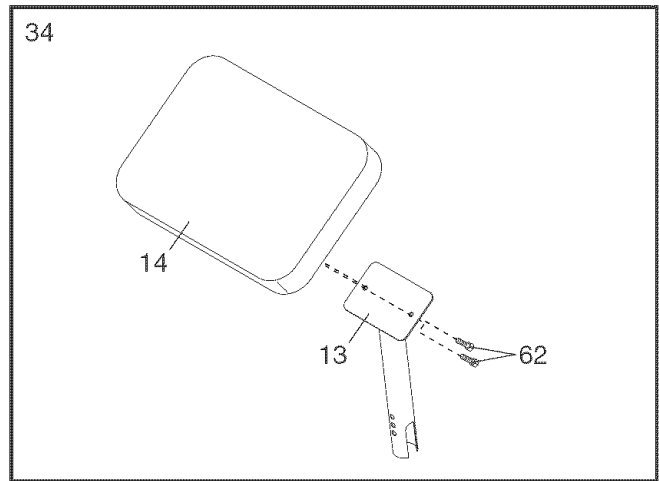

35. Make sure that all parts have been properly tightened. The use of the remaining parts will be explained in ADJUSTMENTS, beginning on the following page.

Before using the weight system, pull each cable a few times to make sure that the cables move smoothly over the pulleys. If one of the cables does not move smoothly, find and correct the problem. **IMPORTANT: If the cables are not properly installed, they may be damaged when heavy weight is used. See the CABLE DIAGRAMS on page 20 of this manual for proper cable routing. If there is any slack in the cables, you will need to remove the slack by tightening the cables. See MAINTENANCE on page 21.**

ADJUSTMENTS

This section explains how to adjust the weight system. See the EXERCISE GUIDELINES on page 22 for important information about how to get the most benefit from your exercise program. Also, refer to the accompanying exercise guide to see the correct form for each exercise.

Make sure all parts are properly tightened each time the weight system is used. Replace any worn parts immediately. The weight system can be cleaned with a damp cloth and a mild, non-abrasive detergent. Do not use solvents.

CHANGING THE WEIGHT SETTING

To change the setting of a weight stack, insert a Weight Pin (26) under the desired Weight (22). Insert the Weight Pin so that the bent end touches the weight stack. Turn the bent end down. **Note: Do not use the Top Weight (25) by itself.**

Note: Due to the cables and pulleys, the amount of resistance at each exercise station may vary from the weight setting. Use the WEIGHT RESISTANCE CHART on page 19 to find the approximate amount of resistance at each weight station.

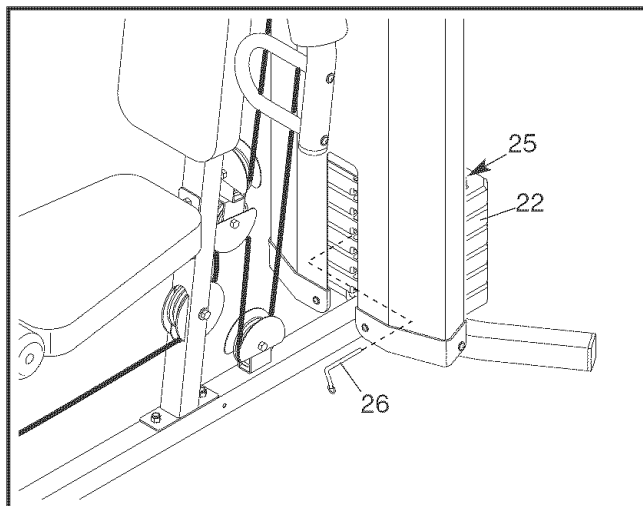

ATTACHING THE ACCESSORIES TO A PULLEY STATION

Attach the Lat Bar (35) to the High Cable (55) at the high pulley station with a Cable Clip (37). For some exercises, the Chain (90) should be attached between the Lat Bar and the Cable with two Cable Clips. **Adjust the length of the Chain between the Lat Bar and the Cable so that the Lat Bar is in the correct starting position for the exercise to be performed.**

The Lat Bar (35) or the Handle Strap (not shown) can be attached at either pulley stations in the same manner. Always engage the Lock Plate (not shown) when using the low pulley station (see USING THE LOCK LEVER below).

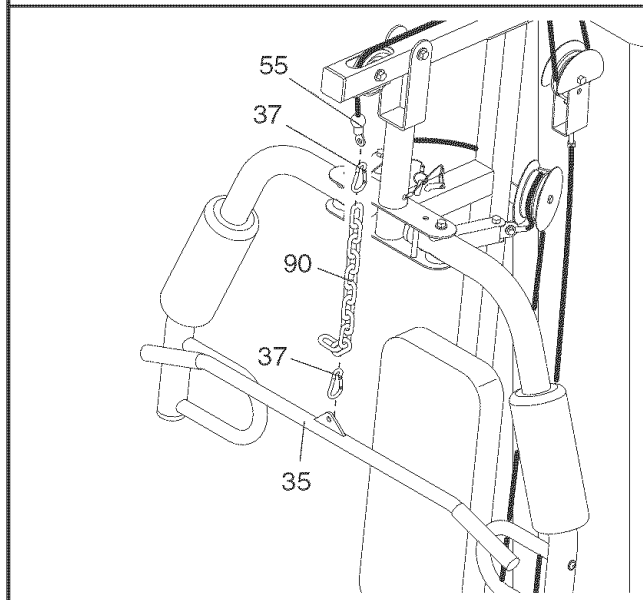

USING THE LOCK LEVER

When using the low pulley station, engage the Leg Lever Pin (38) into the Leg Lever (8) and the Lock Plate (73).

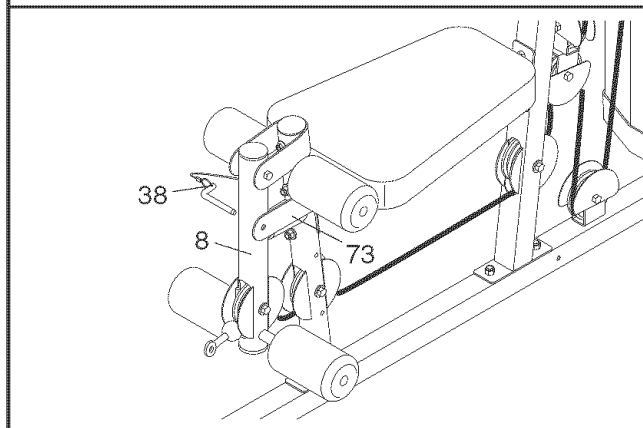

ARM CONVERSION

To use the Arms (9, 10) as butterfly arms, insert the Arm Pins (40) into the holes in the Upright (3) and the Pivot Frame (5) as shown.

To use the Arms (9, 10) as press arms, insert the Arm Pins (40) into the holes in the Pivot Frame (5) and Arms.

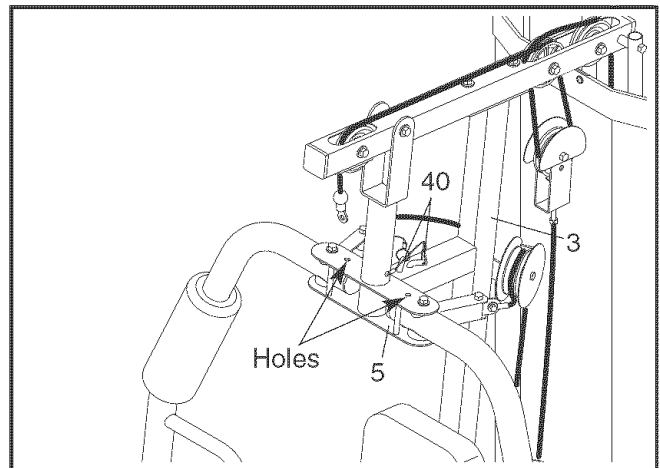

USING THE CURL PAD

To use the Curl Pad (14), remove the 50mm Round Inner Cap (30) from the Front Leg (7). Insert the Curl Post (13) into the Front Leg and secure it in place with the Curl Knob (61).

Remove the Curl Pad (14) and replace the 50mm Round Inner Cap (30) into the Front Leg (7) when performing an exercise that does not require the Curl Pad. Store the Curl Pad away from the weight system.

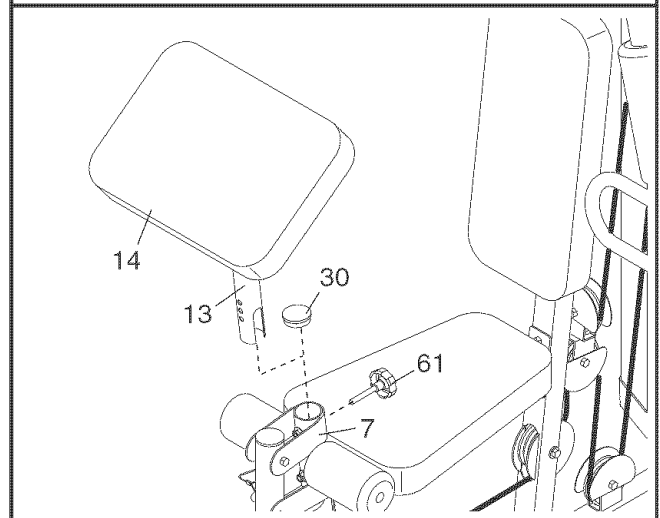

LOCKING THE WEIGHT STACK

Lock the weight stack by inserting the Lock Pin (89) through a Weight Guide (21) and securing the Lock (88) onto the Lock Pin.

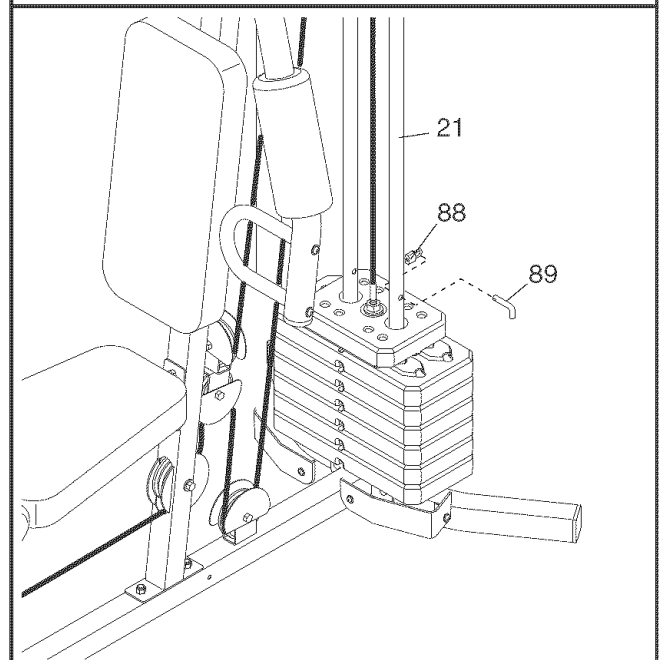

WEIGHT RESISTANCE CHART

The chart below shows the approximate weight resistance at each exercise station. "Top" refers to the 6 lb. top weight. The other numbers refer to the 12.5 lb. weight plates. Weight resistance shown for the butterfly arm station is for each arm. **Note: The actual resistance at each station may vary due to differences in individual weight plates as well as friction between the cables, pulleys, and weight guides.**

WEIGHT	HIGH PULLEY (lbs.)	BUTTERFLY ARM (lbs.)	PRESS ARM (lbs.)	LEG LEVER (lbs.)	LOW PULLEY (lbs.)
Top	11	16	27	27	26
1	26	22	44	57	55
2	42	30	62	85	86
3	61	41	97	111	119
4	70	51	127	159	148
5	86	63	144	182	163
6	101	82	173	214	187

CABLE DIAGRAMS

The cable diagrams below show the proper routing of the Low Cable (53), the Arm Cable (54), and the High Cable (55). Use the diagrams to make sure that the cables, cable traps, and finger guards have been assembled correctly. If the cables have not been correctly routed, the weight system will not function properly and damage may occur. The numbers show the correct route for each cable. **Make sure that the cable traps do not touch or bind the cables.**

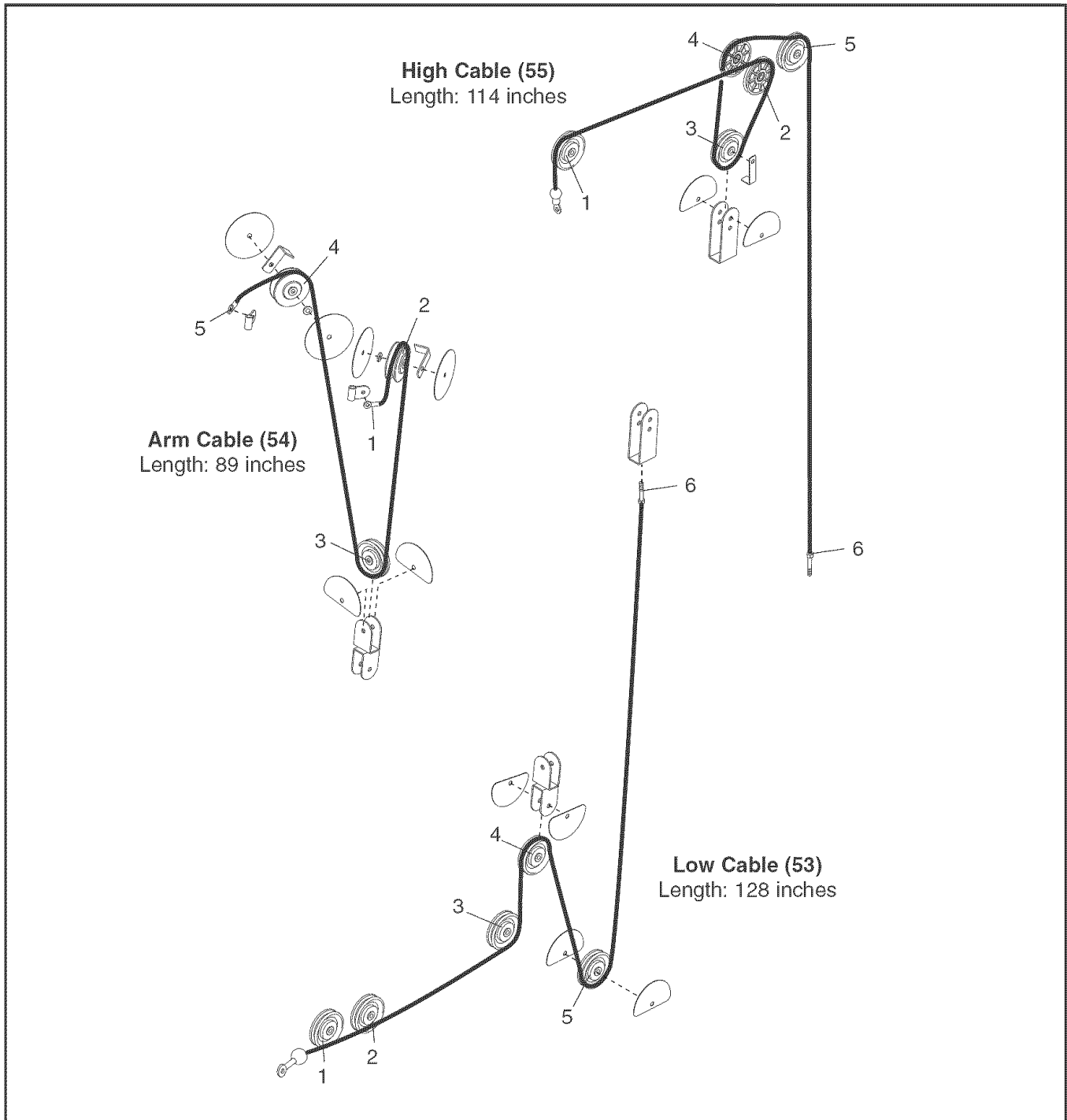

MAINTENANCE

Make sure all parts are properly tightened each time the weight system is used. Replace any worn parts immediately. The weight system can be cleaned with a damp cloth and a mild, non-abrasive detergent. Do not use solvents.

TIGHTENING THE CABLES

Woven cable, the type of cable used on the weight system, can stretch slightly when it is first used. If there is slack in the cables before resistance is felt, the cables should be tightened. To tighten the cables, first insert the weight pin into the middle of the weight stack. Slack can be removed from these cables several ways:

- **See drawing 1.** Tighten the M8 Nylon Locknut (58) that connects the end of the Low Cable (53) to the "U"-bracket (45).
- **See drawing 1.** Remove the M10 Nylon Locknut (56) and the M10 x 51mm Bolt (66) from the Cable Trap (51), 90mm Pulley (48), the two Half Finger Guards (43), and "U"-bracket (45). Reattach the Pulley, Cable Trap, and Finger Guards to the other hole in the "U"-bracket. **Make sure that the Cable Trap is in the proper position and that the Cable and Pulley move smoothly.**
- **See drawing 2.** Loosen the M12 Nut (84) on the High Cable (55). Tighten the High Cable into the Weight Tube (24) until the slack is removed from the Cable. Retighten the M12 Nut against the Large Washer (85).

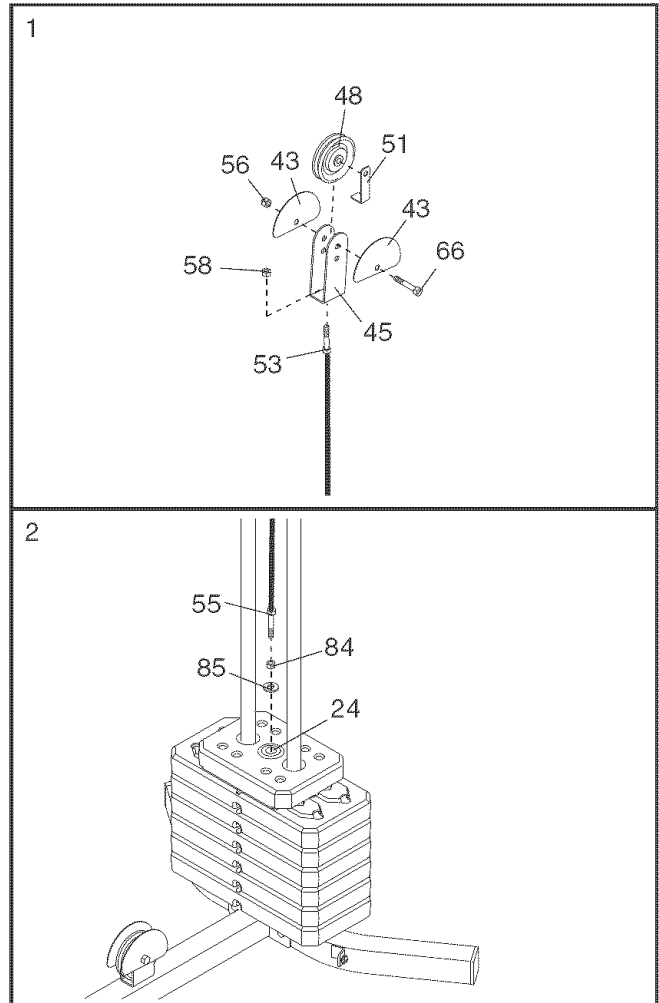

Do not overtighten the cables. If the cables are overtightened, the top weight will be lifted off the weight stack. If a cable tends to slip off the pulleys often, it may have become twisted. Remove the cable and re-install it. If the cables need to be replaced, see ORDERING REPLACEMENT PARTS on the back cover of this manual.

EXERCISE GUIDELINES

THE FOUR BASIC TYPES OF WORKOUTS

Muscle Building

To increase the size and strength of your muscles, push them close to their maximum capacity. Your muscles will continually adapt and grow as you progressively increase the intensity of your exercise. You can adjust the intensity level of an individual exercise in two ways:

- by changing the amount of resistance used
- by changing the number of repetitions or sets performed. (A “repetition” is one complete cycle of an exercise, such as one sit-up. A “set” is a series of repetitions.)

The proper amount of resistance for each exercise depends upon the individual user. You must gauge your limits and select the amount of resistance that is right for you. Begin with 3 sets of 8 repetitions for each exercise you perform. Rest for 3 minutes after each set. When you can complete 3 sets of 12 repetitions without difficulty, increase the amount of resistance.

Toning

You can tone your muscles by pushing them to a moderate percentage of their capacity. Select a moderate amount of resistance and increase the number of repetitions in each set. Complete as many sets of 15 to 20 repetitions as possible without discomfort. Rest for 1 minute after each set. Work your muscles by completing more sets rather than by using high amounts of resistance.

Weight Loss

To lose weight, use a low amount of resistance and increase the number of repetitions in each set. Exercise for 20 to 30 minutes, resting for a maximum of 30 seconds between sets.

Cross Training

Cross training is an efficient way to get a complete and well-balanced fitness program. An example of a balanced program is:

- Plan strength training workouts on Monday, Wednesday, and Friday.
- Plan 20 to 30 minutes of aerobic exercise, such as running on a treadmill or riding on an elliptical exerciser or exercise bike, on Tuesday and Thursday.
- Rest from both strength training and aerobic exercise for at least one full day each week to give your body time to regenerate.

The combination of strength training and aerobic exercise will reshape and strengthen your body, plus develop your heart and lungs.

PERSONALIZING YOUR EXERCISE PROGRAM

Determining the exact length of time for each workout, as well as the number of repetitions or sets completed, is an individual matter. It is important to avoid overdoing it during the first few months of your exercise program. You should progress at your own pace and be sensitive to your body’s signals. If you experience pain or dizziness at any time while exercising, stop immediately and begin cooling down. Find out what is wrong before continuing. Remember that adequate rest and a proper diet are important factors in any exercise program.

WARMING UP

Begin each workout with 5 to 10 minutes of stretching and light exercise to warm up. Warming up prepares your body for more strenuous exercise by increasing circulation, raising your body temperature and delivering more oxygen to your muscles.

WORKING OUT

Each workout should include 6 to 10 different exercises. Select exercises for every major muscle group, emphasizing areas that you want to develop most. To give balance and variety to your workouts, vary the exercises from session to session.

Schedule your workouts for the time of day when your energy level is the highest. Each workout should be followed by at least one day of rest. Once you find the schedule that is right for you, stick with it.

EXERCISE FORM

Maintaining proper form is an essential part of an effective exercise program. This requires moving through the full range of motion for each exercise, and moving only the appropriate parts of the body. Exercising in an uncontrolled manner will leave you feeling exhausted. On the exercise guide accompanying this manual you will find photographs showing the correct form for several exercises, and a list of the muscles affected. Refer to the muscle chart on the next page to find the names of the muscles.

The repetitions in each set should be performed smoothly and without pausing. The exertion stage of each repetition should last about half as long as the return stage. Proper breathing is important. Exhale during the exertion stage of each repetition and inhale during the return stroke. Never hold your breath.

Rest for a short period of time after each set. The ideal resting periods are:

- Rest for three minutes after each set for a muscle building workout.
- Rest for one minute after each set for a toning workout.
- Rest for 30 seconds after each set for a weight loss workout.

Plan to spend the first couple of weeks familiarizing yourself with the equipment and learning the proper form for each exercise.

COOLING DOWN

End each workout with 5 to 10 minutes of stretching. Include stretches for both your arms and legs. Move

slowly as you stretch and do not bounce. Ease into each stretch gradually and go only as far as you can without strain. Stretching at the end of each workout is an effective way to increase flexibility.

STAYING MOTIVATED

For motivation, keep a record of each workout. List the date, the exercises performed, the resistance used, and the numbers of sets and repetitions completed. Record your weight and key body measurements at the end of every month. Remember, the key to achieving the greatest results is to make exercise a regular and enjoyable part of your everyday life.

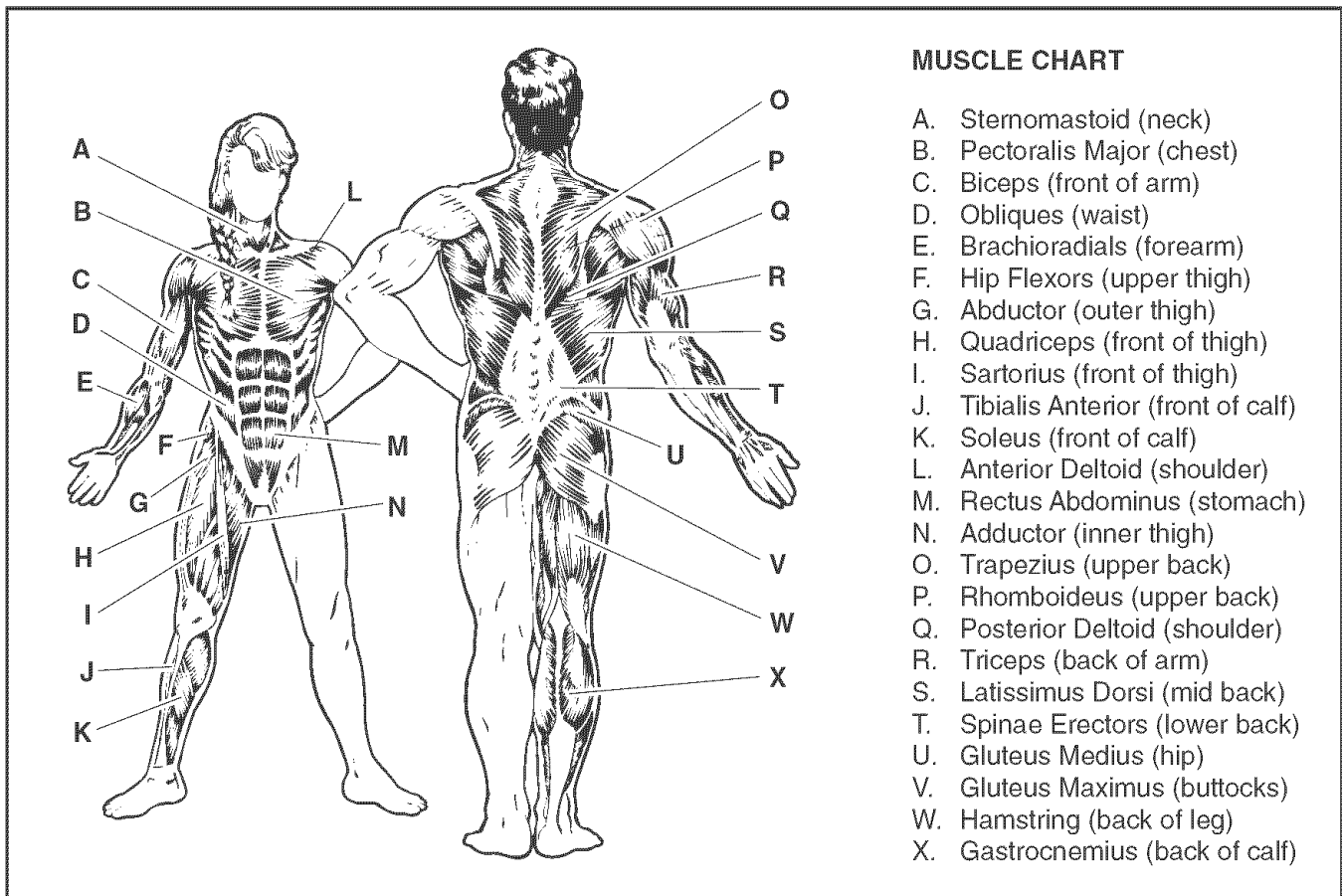

PART LIST—Model No. WESY19540

R0704A

Key No.	Qty.	Description	Key No.	Qty.	Description
1	1	Base	49	2	11mm Spacer
2	1	Stabilizer	50	2	Large Cable Trap
3	1	Upright	51	1	Cable Trap
4	1	Top Frame	52	10	12mm Spacer
5	1	Pivot Frame	53	1	Low Cable
6	1	Seat Frame	54	1	Arm Cable
7	1	Front Leg	55	1	High Cable
8	1	Leg Lever	56	26	M10 Nylon Locknut
9	1	Right Arm	57	31	M10 Washer
10	1	Left Arm	58	9	M8 Nylon Locknut
11	2	Handle	59	5	M8 Washer
12	1	Square Plate	60	1	Leg Bumper
13	1	Curl Post	61	1	Curl Knob
14	1	Curl Pad	62	12	M6 x 16mm Screw
15	1	Seat	63	1	Double "U"-bracket
16	1	Backrest	64	2	M5 x 20mm Self-tapping Screw
17	1	Shroud	65	2	M8 x 22mm Shoulder Bolt
18	1	Top Cap	66	3	M10 x 51mm Bolt
19	1	Left Cap	67	2	M10 x 85mm Bolt
20	1	Right Cap	68	4	M8 x 65mm Bolt
21	2	Weight Guide	69	4	M4 x 20mm Self-tapping Screw
22	6	Weight	70	2	M6 x 63mm Screw
23	1	Weight Tube Cap	71	10	M10 x 67mm Bolt
24	1	Weight Tube	72	2	M5 Washer
25	1	Top Weight	73	1	Lock Plate
26	1	Weight Pin	74	1	M10 x 155mm Bolt
27	2	Weight Bumper	75	2	M10 x 63mm Bolt
28	4	Small Foam Pad	76	2	19mm Spacer
29	1	Pad Tube	77	4	M10 x 25mm Button Bolt
30	7	50mm Round Inner Cap	78	2	M10 x 65mm Carriage Bolt
31	5	50mm Square Inner Cap	79	1	M10 x 77mm Bolt
32	1	50mm Square Outer Cap	80	1	M10 x 80mm Bolt
33	1	M4 Washer	81	3	M10 x 48mm Bolt
34	4	19mm Round Inner Cap	82	10	M6 Washer
35	1	Lat Bar	83	1	50mm Thick Round Inner Cap
36	2	Handgrip	84	1	M12 Nut
37	3	Cable Clip	85	1	Large Washer
38	1	Leg Lever Pin	86	1	M10 x 70mm Bolt
39	2	Cable Pivot	87	2	M8 x 63mm Carriage Bolt
40	2	Arm Pin	88	1	Lock
41	4	Full Finger Guard	89	1	Lock Pin
42	2	Large Foam Pad	90	1	Chain
43	8	Half Finger Guard	91	1	Handle Strap
44	4	Arm Bushings	92	2	M6 Locknut
45	1	"U"-bracket	#	1	User's Manual
46	2	"V"-pulley	#	1	Exercise Guide
47	2	90mm Thin Pulley	#	2	Grease Packet
48	9	90mm Pulley			

Note: "#" indicates a non-illustrated part. Specifications are subject to change without notice. See the back cover of the user's manual for information about ordering replacement parts.

PART IDENTIFICATION CHART

Refer to the drawings below to identify small parts used in assembly. The number in parentheses by each drawing is the key number of the part, from the PART LIST in the center of this manual. **Note: Some small parts may have been pre-attached. If a part is not in the parts bag, check to see if it has been pre-attached.**



M6 Locknut (92)

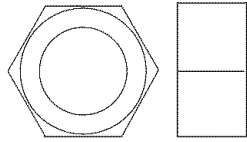

M12 Nut (84)

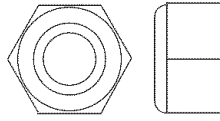

M10 Nylon Locknut (56)

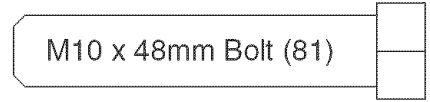

M10 x 48mm Bolt (81)

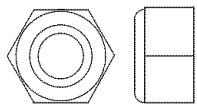

M8 Nylon Locknut (58)

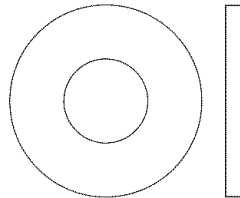

M10 Washer (57)

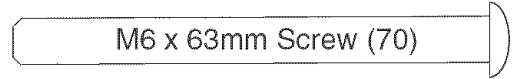

M6 x 63mm Screw (70)

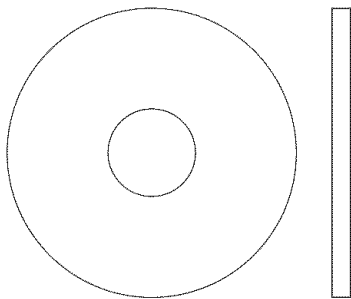

Large Washer (85)

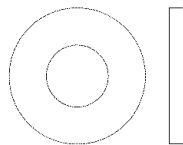

M8 Washer (59)

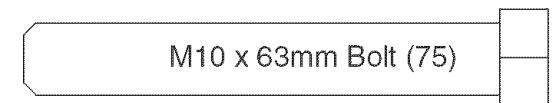

M10 x 63mm Bolt (75)

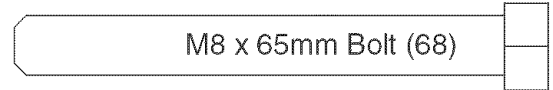

M8 x 65mm Bolt (68)

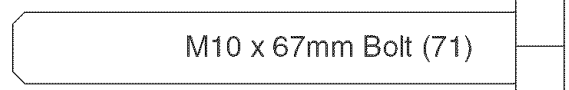

M10 x 67mm Bolt (71)

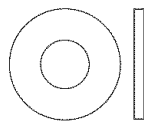

M6 Washer (82)

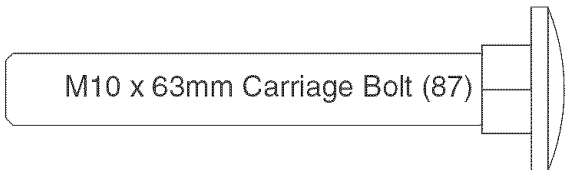

M10 x 63mm Carriage Bolt (87)

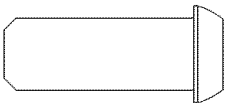

M10 x 25mm Button Bolt (77)



M4 Washer (33)



M10 x 65mm Carriage Bolt (78)

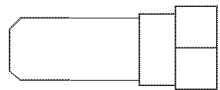

M8 x 22mm Shoulder Bolt (65)

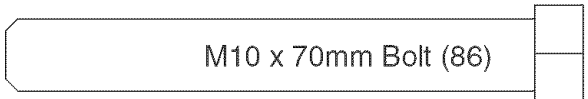

M10 x 70mm Bolt (86)



M4 x 20mm Self-tapping Screw (69)

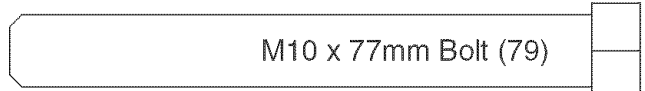

M10 x 77mm Bolt (79)



M5 x 20mm Self-tapping Screw (64)

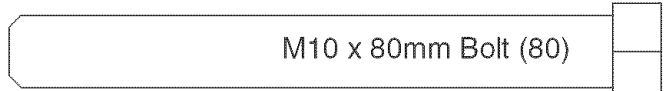

M10 x 80mm Bolt (80)

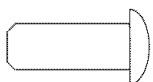

M6 x 16mm Screw (62)

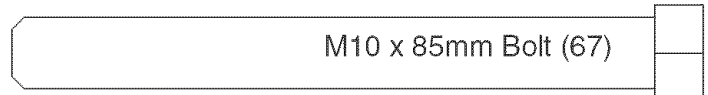

M10 x 85mm Bolt (67)

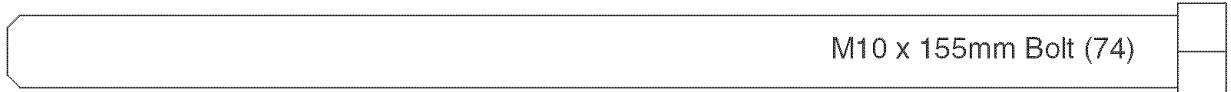

M10 x 155mm Bolt (74)

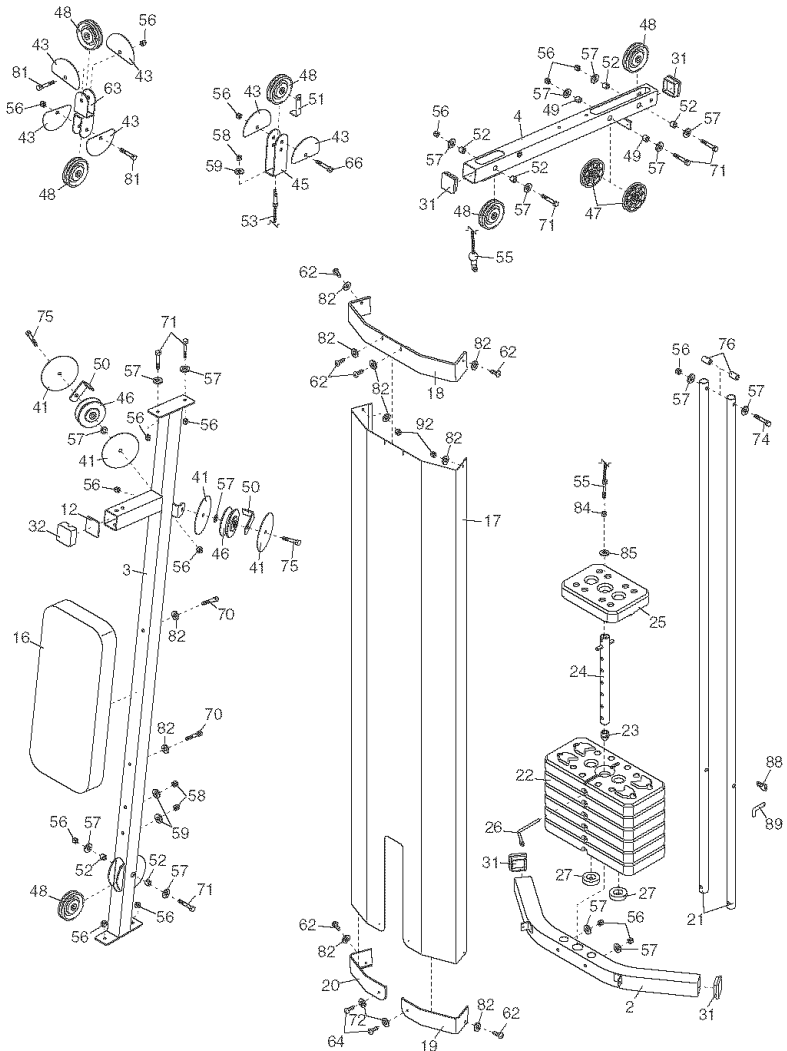
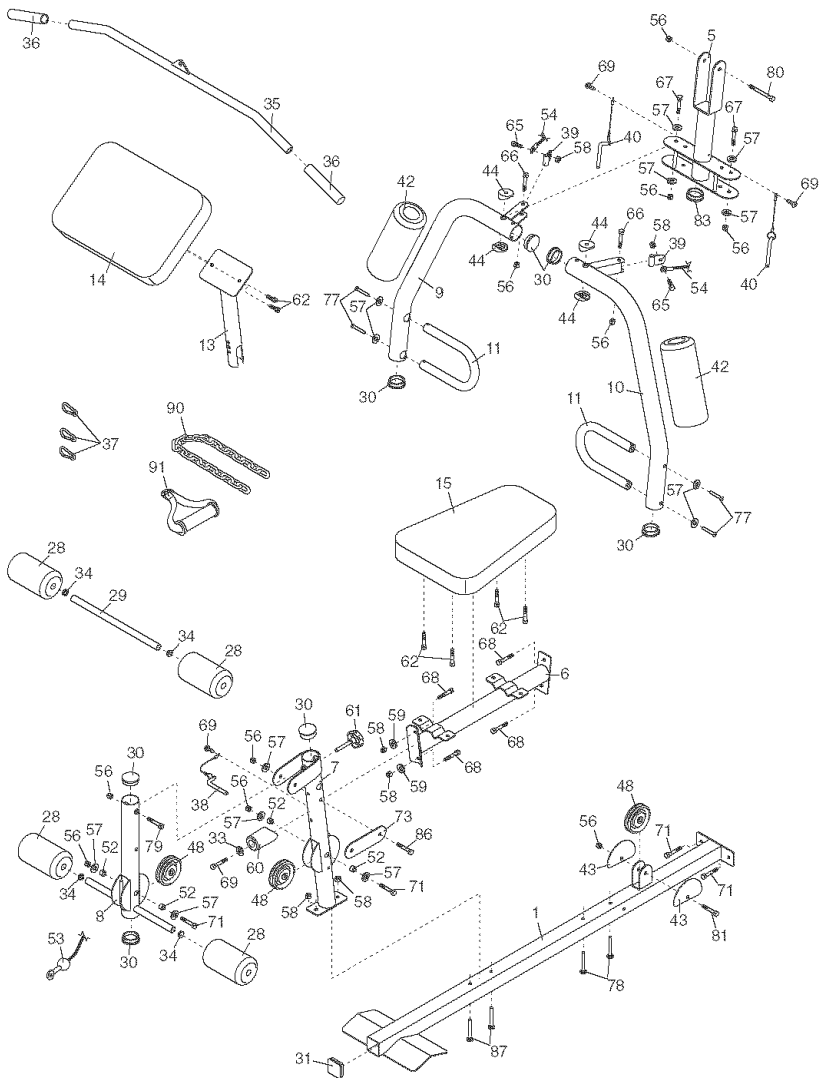

EXPLODED DRAWING—Model No. WESY19540

R0704A

ORDERING REPLACEMENT PARTS

To order replacement parts, simply call our Customer Service Department toll-free at 1-877-992-5999, Monday through Friday, 6 a.m. until 6 p.m. Mountain Time (excluding holidays). To help us assist you, please be prepared to give the following information:

1. The MODEL NUMBER of the product (WESY19540)
2. The NAME of the product (WEIDER® 1120 weight system)
3. The SERIAL NUMBER of the product (see the front cover of this manual)
4. The KEY NUMBER and DESCRIPTION of the part(s) (see the PART LIST and EXPLODED DRAWING at the center of this manual)

LIMITED WARRANTY

ICON Health & Fitness, Inc. (ICON), warrants this product to be free from defects in workmanship and material, under normal use and service conditions, for a period of ninety (90) days from the date of purchase. This warranty extends only to the original purchaser. ICON's obligation under this warranty is limited to replacing or repairing, at ICON's option, the product through one of its authorized service centers. All repairs for which warranty claims are made must be pre-authorized by ICON. This warranty does not extend to any product or damage to a product caused by or attributable to freight damage, abuse, misuse, improper or abnormal usage or repairs not provided by an ICON authorized service center; products used for commercial or rental purposes; or products used as store display models. No other warranty beyond that specifically set forth above is authorized by ICON.

ICON is not responsible or liable for indirect, special or consequential damages arising out of or in connection with the use or performance of the product or damages with respect to any economic loss, loss of property, loss of revenues or profits, loss of enjoyment or use, costs of removal or installation or other consequential damages of whatsoever nature. Some states do not allow the exclusion or limitation of incidental or consequential damages. Accordingly, the above limitation may not apply to you.

The warranty extended hereunder is in lieu of any and all other warranties and any implied warranties of merchantability or fitness for a particular purpose is limited in its scope and duration to the terms set forth herein. Some states do not allow limitations on how long an implied warranty lasts. Accordingly, the above limitation may not apply to you.

This warranty gives you specific legal rights. You may also have other rights which vary from state to state.

ICON HEALTH & FITNESS, INC., 1500 S. 1000 W., LOGAN, UT 84321-9813