

Assembly Instructions/Use and Care Manual

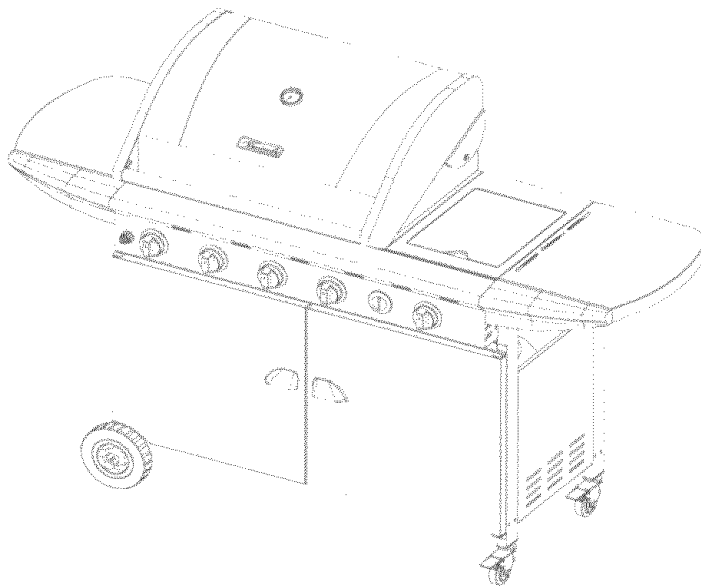

Liquid Propane Gas Grill

Model No.: 122.16119



- Parts
- Assembly
- Safety Rules
- Use and Care
- Troubleshooting
- Español



WARNING:

Read this Owner's manual carefully and be sure your gas grill is properly assembled, installed and maintained. Failure to follow these instructions could result in serious injury and/or property damage. This gas grill is intended for outdoor use only and is not intended to be installed in or on recreational vehicles or boats.

Note to Installer

Leave this Owner's Manual with the customer after delivery and/or installation.

Note to Consumer

Leave this Owner's Manual in a convenient place for future reference.

Customer Service Helpline:

For parts ordering, call:
1-800-4-MY-HOME

For assembly questions, call:
1-800-913-8999

Date: 2006/10/26

HI6Y06P-1

Table of Contents

Warranty	2
Safety Precautions	2~4
Hardware List	5
Parts Diagram	6
Parts List	7
Assembly Instructions	8~13
Lighting Instructions	14~15
Cleaning and Maintenance	16~17
Troubleshooting	18
Cooking Instruction	19
Cooking Chart	20

Kenmore Grill Warranty

One-Year Full Warranty on Kenmore Grill

If this grill fails due to a defecting material or workmanship within one year from the date of purchase, call 1-800-MY-HOME to arrange for free repair (or replacement if repair proves impossible).

Five-Year Limited Warranty on Stainless Steel Burners

For five years from the date of purchase, any stainless steel burner that rusts through will be replaced free of charge. After the first year from the date of purchase, you pay for labor if you wish to have it installed.

All warranty coverage excludes ignitor batteries and grill part paint loss, discoloration or rusting, which are either expendable parts that can wear out from normal use within the warranty period, or are conditions that can be the result of normal use, accident or improper maintenance.

All warranty coverage is void if this grill is ever used for commercial or rental purposes.

All warranty coverage applies only if this grill is used in the United States.

This warranty gives you specific legal rights, and you may have other right which vary from state to state.

Sears, Roebuck and Co.,
Hoffman Estates, IL 60179
U.S.A.

PRECAUTIONS

WARNING

Combustion by products produced when using this product contain chemicals known to the State of California to cause cancer, birth defects, or other reproductive harm.

WARNING

Failure to comply with these instructions could result in a fire or explosion that could cause serious bodily injury, death, or property damage.

WARNING

Your grill will get very hot. Never lean over the cooking area while using your grill. Do not touch cooking surfaces, grill housing, lid or any other grill parts while the grill is in operation, or until the gas grill has cooled down after use.

Failure to comply with these instructions may result in serious bodily injury.

WARNING

1. Do not store or use gasoline or other flammable material and liquids in the vicinity of this or any other appliance.
2. A LP cylinder not connected for use must not be stored in the vicinity of this or any other appliance.

DANGER

If you smell gas:

1. Shut off gas to the appliance.
2. Extinguish any open flame.
3. Open Lid.
4. If odor continues, keep away from the appliance and immediately call your gas supplier or your fire department.

Grill Installation Codes

The installation must conform with local codes or, in the absence of local codes, with either the national fuel gas code, ANSIZ 223.1/NFPA S4, Natural gas and propane installation code, CSA B149.1, or propane storage and handling code, B149.2, or the standard for Recreational vehicles, ANSI A 119.2, and CSA Z240 RV series recreational vehicle code, as applicable. LP gas grill models are designed for use with a standard 20 lb. Liquid Propane Gas tank, not included with grill. Never connect your gas grill to an LP gas tank that exceeds this capacity.

PRECAUTIONS

A tank of approximately 12 inches in diameter by 18-1/2 inches high is the maximum size LP gas tank to use. **You must use an OPD gas tank which offers an Overfill Prevention Device.**

This safety feature prevents the tank from being overfilled which can cause malfunction of the LP gas tank, regulator and/or grill.

The LP gas tank must be constructed and marked in accordance with specifications of the U.S. Dept. of Transportation (DOT). In Canada, the LP gas tank must meet the National Standard of Canada, Can CSA -B339, Cylinders, spheres and Tubes for Transportation of Dangerous Goods and Commission.

1. The LP gas tank must have a shutoff valve, terminating in an LP gas supply tank valve outlet, that is compatible with a Type 1 tank connection device.

The LP gas tank must also have a safety relief device that has a direct connection with the vapor space of the tank.

2. The tank supply system must be arranged for vapor withdraw.

3. The LP gas tank used must have a collar to protect the tank valve.

Proper Placement and Clearance of Grill

Never use your gas grill in a garage, porch, shed, breezeway or any other enclosed area. Your gas grill is to be used **outdoors only**, at least 24 inches from the back and side of any combustible surface. Your gas grill should not be used under overhead combustible construction. Do not obstruct the flow of ventilation air around the gas grill housing.

- Do not install this outdoor gas grill in or on recreational vehicles or boats

- Keep outdoor gas grill area clear and free from combustible materials, gasoline and other flammable vapors and liquids

- Do not obstruct the flow of combustion and ventilation air. Check for this each time prior to using grill.

- **Never** connect an unregulated LP gas tank to your gas grill. The gas regulator assembly supplied with your gas grill is adjusted to have an outlet pressure of 11" water column (W.C.) for connection to an LP gas tank.

- Only use the regulator and the hose assembly supplied with your gas grill. Replacement regulators and hose assemblies must be those specified in this manual.

- Have your LP gas tank filled by a reputable propane gas dealer and visually inspected and re-qualified at each filling.
- Do not store a spare LP gas tank under or near this appliance.
- Never fill the tank beyond 80 percent full. If this information is not followed exactly a fire causing death or serious injury may occur.
- Always keep LP gas tanks in an upright position.
- Do not store (or) or use gasoline or other flammable vapors and liquids in the vicinity of this gas grill.
- Do not subject the LP gas tank to excessive heat.
- Never store an LP gas tank indoors. If you store your gas grill in the garage or other indoor location, **always** disconnect the LP gas tank first and store it safely outside.



- Place dust cap on tank valve outlet whenever the tank is not in use. Only install the type of dust cap on the tank valve outlet that is provided with the tank valve. Other types of caps or plugs may result in leakage of propane.
- LP gas tanks must be stored outdoors in a well-ventilated area and out of reach of children. Disconnected LP gas tanks must not be stored in a building, garage or any other enclosed area.
- When your gas grill is not in use the gas must be turned off at the LP gas tank.
- The regulator and hose assembly must be inspected before each use of the grill. If there is excessive abrasion or wear or if the hose is cut, it must be replaced prior to the grill being used again.
- Keep the gas regulator hose away from hot grill surfaces and dripping grease. Avoid unnecessary twisting of hose. Visually inspect the hose prior to each use for cuts, cracks, excessive wear or other damage. If the hose appears damaged do not use the gas grill. Call 1-800-4-MY-HOME for assistance.
- **Never** light your gas grill with the lid closed or before checking to ensure the burner tubes are fully seated over the gas valve orifices.
- **Never** allow children to operate your grill.



WARNING

A strong gas smell, or the hissing sound of gas indicates a serious problem with your gas grill or the LP gas tank. Failure to immediately follow the steps listed below could result in a fire or explosion that could cause serious bodily injury, death, or property damage.

- Shut off gas supply to the gas grill.
- Turn the control knobs to OFF position.
- Put out any flame with a proper fire extinguisher.
- Open Grill Lid.
- Get away from the LP gas tank.
- Do not try to fix the problem yourself.
- If odor continues or you have a fire you can not extinguish, call your fire department. Do not call near the LP gas tank because your telephone is a form of electrical device and could create a spark resulting in fire and/or explosion.

NOTE: The normal flow of gas through the regulator and hose assembly can create a humming noise. A low volume of noise is perfectly normal and will not interfere with operation of the grill. If humming noise is loud and excessive you may need to purge air from the gas line or reset the regulator excess gas flow device. This purging procedure should be done every time a new LP gas tank is connected to your grill. For help with this procedure refer to page 15, step 4, or call the Customer Service Helpline 8 AM to 5 PM EST at: 1-800-4-MY-HOME

CAUTION: Beware of Flash-back

CAUTION: Spiders and small insects occasionally spin webs or make nests in the grill burner tubes during transit and warehousing. These webs can lead to gas flow obstruction which could result in a fire in and around burner tubes. This type of fire is known as "FLASH-BACK" and can cause serious damage to your grill and create an unsafe operating condition for the user.

Although an obstructed burner tube is not the only cause of "FLASH-BACK", it is the most common cause.

To reduce the chance of "FLASH-BACK", you must clean the burner tubes before assembling your grill, and at least once a month in late summer or early fall when spiders are most active. Also perform this burner tube cleaning procedure if your grill has not been used for an extended period of time.

See Cleaning Burner Tubes and Ports on page # 17

Burner Flame Check

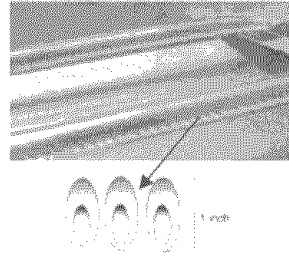

Visually check the burner flames prior to each use. The flames should look like picture, if they do not, refer to the cleaning burner tubes and ports, see page 17 of this manual.

Repair Protection Agreements

Congratulations on making a smart purchase. Your new Kenmore product is designed and manufactured for years of dependable operation. But like all products, it may require repair from time to time. That's when having a Repair Protection Agreement can save you money and aggravation.

Purchase a Repair Protection Agreement now and protect yourself from unexpected hassle and expense. Here's what's included in the Agreement:

- Expert service by our 12,000 professional repair specialists
- Unlimited service and no charge for parts and labor on all covered repairs
- Product replacement if your covered product can not be fixed
- Discount of 10% from regular price of service and service-related parts not covered by the agreement, also, 10% off regular price of preventive maintenance check
- Fast help by phone-phone support from a Sears technician on products requiring in-home repair, plus convenient repair scheduling









Once you purchase the Agreement, a simple phone call is all that it takes for you to schedule service. You can call anytime day or night, or schedule a service appointment online.

Some limitations and exclusions apply.

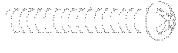
For prices and additional information call 1 -800-827-6655.

Contents for Hardware Pack

The following table illustrates a breakdown of the hardware pack. It highlights what components are used in the various stages of assembly.

Item	Description	Specification	Quantity
1	Phillips Head Screw 	1/4 x 1.38"	8 pcs
2	Phillips Head Screw 	1/4 x 3/5"	19 pcs
3	Phillips Head Screw 	5/32 x 2/5"	19 pcs
4	Phillips Head Screw 	5/32 x 1.38"	1 pcs
5	Hex Nut 	1/4"	2 pcs
6	Hex Nut 	5/32"	3 pcs
7	Flat Washer 	1/4"	6 pcs
8	Lock Washer 	1/4"	23 pcs
9	Lock Washer 	5/32"	20 pcs

Model 122.16119 Parts Diagram

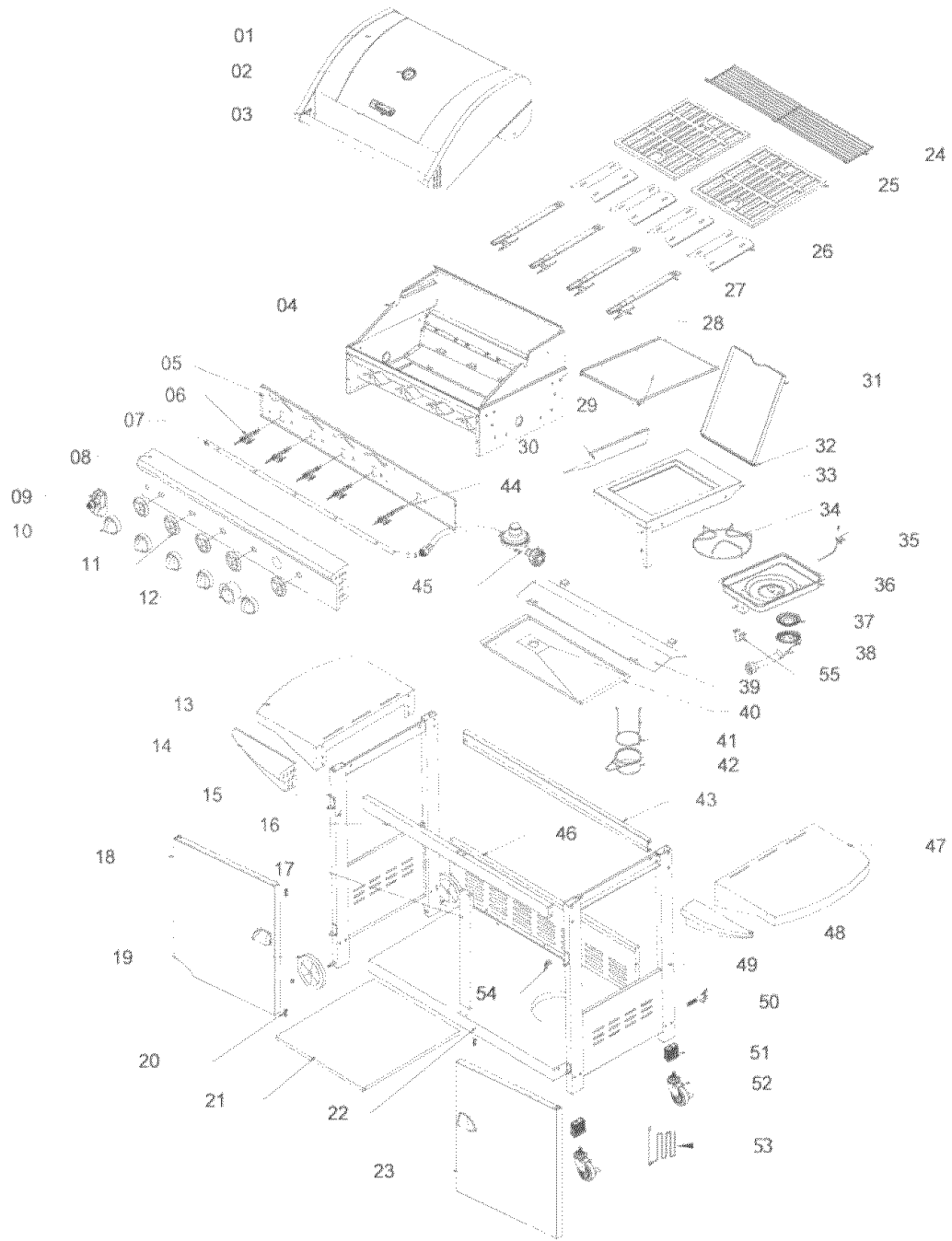

Model 122.16119 Parts List

KEY#	PARTS #	DESCRIPTION	Q'TY	KEY#	PARTS #	DESCRIPTION	Q'TY
1	341-001	Main Lid	1	30	341-030	Tank Heat Shield	1
2	341-002	Temperature Gauge	1	31	341-031	Side Burner Lid	1
3	341-003	Logo	1	32	341-032	Side Burner Lid Hinge Rod	1
4	341-004	Main Burner bowl assembly	1	33	341-033	Side Burner Bowl Assembly Frame	1
5	341-005	Front Baffle	1	34	341-034	Side Burner Cooking Grate	1
6	341-006	Main Gas Valve(Cast brass)	4	35	341-035	Side Burner Igniter Wire	1
7	341-007	Main Manifold	1	36	341-036	Side Burner Bowl Assembly Firebox	1
8	341-008	Main Control Panel Assembly	1	37	341-037	Side Burner Head	1
9	341-009	Pulse Igniter Module	1	38	341-038	Side Burner, Pipe	1
10	341-010	Control Knob	5	39	341-039	Grease Slide Panel, Top	1
11	341-011	Bezel	5	40	341-040	Grease Slide Panel, Bottom	1
12	341-012	Timer	1	41	341-041	Grease Cup Holder	1
13	341-013	Side Shelf, Left	1	42	341-042	Grease Cup	1
14	341-014	Side Shelf Front Panel, Left	1	43	341-043	Cart Frame, Rear	1
15	341-015	Side Panel ,Left	1	44	341-044	Side Gas Valve	1
16	341-016	Cart Frame, Front	1	45	341-045	Regulator, LP	1
17	341-017	Cart Front Support	1	46	341-046	Back Panel	1
18	341-018	Front Door, Left	1	47	341-047	Side Shelf ,Right	1
19	341-019	Wheel	2	48	341-048	Side Shelf Front Panel, Right	1
20	341-020	Door Magnet	4	49	341-049	Side Panel, Right	1
21	341-021	Cart Clapboard	1	50	341-050	Tank Bolt	1
22	341-022	Bottom Panel	1	51	341-051	Cart Caster Insert	2
23	341-023	Front Door, Right	1	52	341-052	Swivel Caster With Brake	2
24	341-024	Warming Rack	1	53	341-053	Lighting Rod	1
25	341-025	Cooking Grids with Hole (Cast iron)	2	54	341-054	Regulator Hose Retention Clamp	1
26	341-026	Flame Tamer	4	55	341-055	Side Burner Bracket	1
27	341-027	Main Burner	4	56	341-056	Manual	1
28	341-028	Main Burner Igniter Wire	4	57	341-057	Hardware Pack	1
29	341-029	Tank Heat Shield, Piece	1				

For assembly questions, call:
1-800-913-899

For parts ordering, please call:
1-800-4-MY-HOME

To make sure you obtain the correct replacement parts for your Kenmore gas grill, please refer to the part numbers on this page.

Important: Use only parts listed above. When ordering parts, providing the following information:

1. Model #
2. Part Number (see PART# in chart)
3. Part Description
4. Quantity of parts needed

Important: Keep this Owner's Manual for convenient reference and for part replacement.

Assembly Instructions

CAUTION: While it is possible for one person to assemble this grill, obtain assistance from another person when handling some of the larger, heavier pieces

1. Open lid of shipping carton and remove top sheet of cardboard. Lay cardboard sheet on floor and use as a work surface to protect floor and grill parts from scratches.
2. Remove packing materials from shipping carton.
3. You may slice the carton front corners with a utility knife to lay open the carton front panel. This will allow you to raise the grill head lid and remove the components packed inside the head
4. Use the parts list to check that all parts have been included.
5. Inspect the grill for damage as you assemble it. Do not assemble or operate the grill if it appears damaged. If there are damaged or missing parts when you unpack the shipping box, or you have questions during the assembly process, call:

**For Assembly Questions, call 1-800-913-8999
8am – 5pm EST, Monday through Friday.**

Assembling Grill Cart

1. Attach the wheels to left side panel using (2) $\frac{1}{4}$ " hex nuts with (2) $\frac{1}{4}$ " flat washers. (Fig.1)
2. Attach the locking casters to the bottom of the right side panel legs. Then tighten caster screw securely using hex nut wrench provided in parts pack. (Fig.2)
3. Assemble cart leg with bottom panel using (8) $\frac{1}{4} \times \frac{7}{8}$ " Phillips head screw and (8) $\frac{1}{4}$ " lock washers.(Fig.3)
4. Attach the back panel to the cart legs using (4) $\frac{1}{4} \times \frac{3}{5}$ " Phillips head screws and (4) $\frac{1}{4}$ " lock washers. (Fig.4)

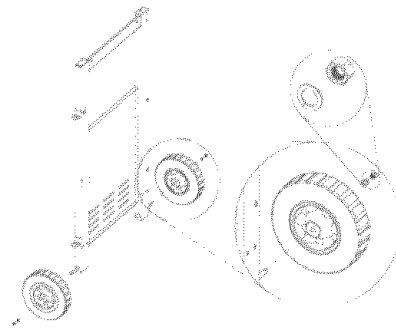

Figure 1

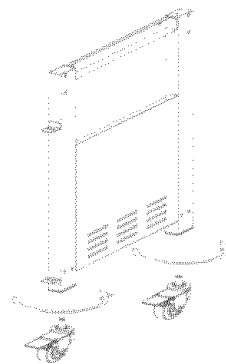

Figure 2

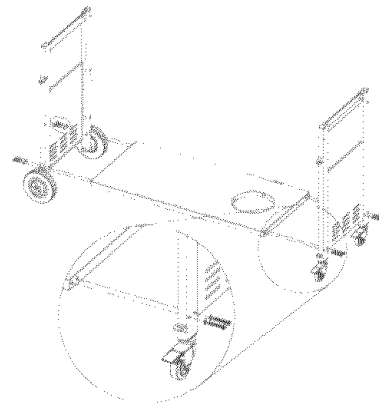

Figure 3

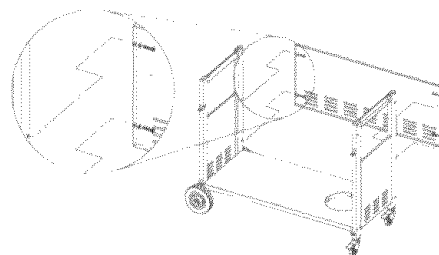

Figure 4

Installing Doors

1. Attach the front cart frame beam to the grill cart using (2) $\frac{1}{4}$ x $\frac{3}{5}$ " Phillips head screw and (2) $\frac{1}{4}$ " lock washers. (Fig.5)

2. Attach the rear cart frame beam to grill cart using (4) $\frac{5}{32}$ x $\frac{2}{5}$ " Phillips head screws and (4) $\frac{5}{32}$ " lock washers. (Fig.6)

3. Attach the cart front support to the front cart frame beam and bottom panel using (4) $\frac{5}{32}$ x $\frac{2}{5}$ " Phillips head screw and (4) $\frac{5}{32}$ " lock washers. (Fig.7)

4. Attach the cart clapboard to the rear panel and front cart support using (4) $\frac{5}{32}$ x $\frac{2}{5}$ " Phillips head screws and (4) $\frac{5}{32}$ " lock washers. (Fig.8)

5. Insert right door bottom hinge pin into hole in door bottom bracket on cart. Push down on top door hinge pin to insert it into hole in door top bracket on cart. Repeat for other door. (Fig.9)

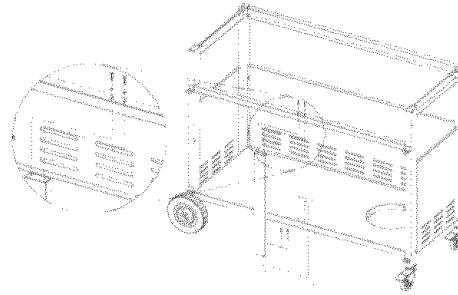

Figure 7

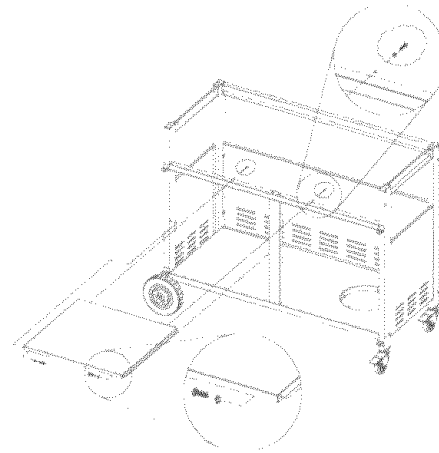

Figure 8

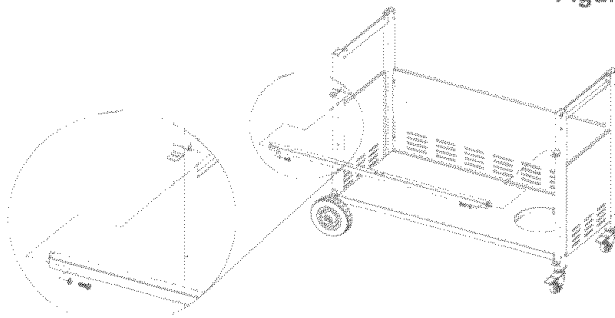

Figure 5

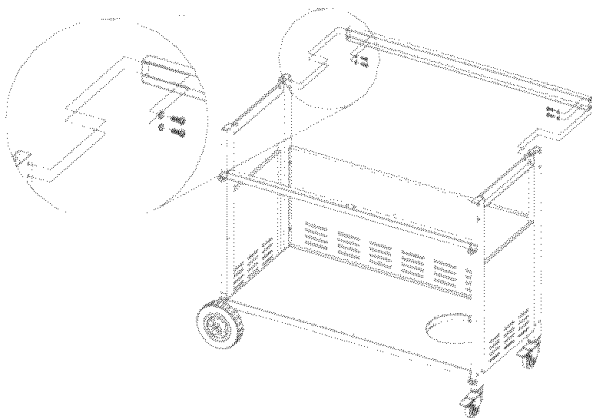

Figure 6

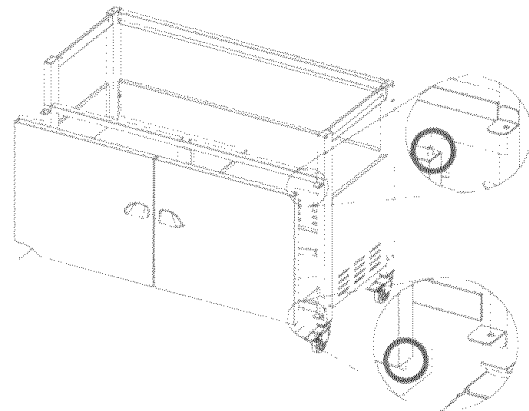

Figure 9

Installing Grill Head

1. Remove grill head unit from carton, then place onto cart from above as shown on diagram (below). **Caution!! Head unit is heavy. To avoid injury, we strongly recommend 2 or more persons for this step.**

3. Align screw holes located on the outside of the grill.
(Fig. 10)

3. Attach the grill head to right side panel using (4) $\frac{1}{4}$ x $\frac{3}{5}$ " screws with (4) $\frac{1}{4}$ " washers. (Fig. 11)

4. Using (2) $\frac{5}{32}$ x $\frac{2}{5}$ " Phillips head screws and (2) $\frac{5}{32}$ " lock washers, attach the side burner heat shield and tank heat shield together. Use (4) $\frac{5}{32}$ x $\frac{2}{5}$ " Phillips head screws with (4) $\frac{5}{32}$ " lock washers to attach the shield assembly to the leg and firebox bottom. See (Fig 12.)

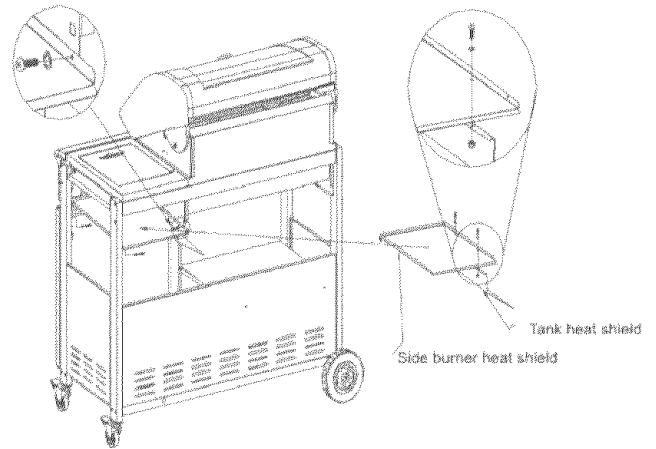

Figure 12

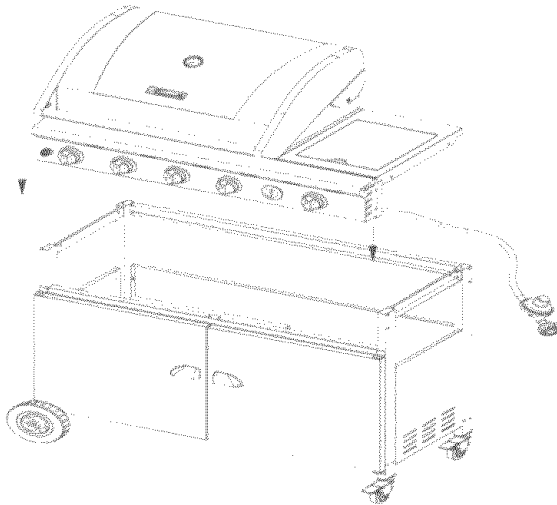

Figure 10

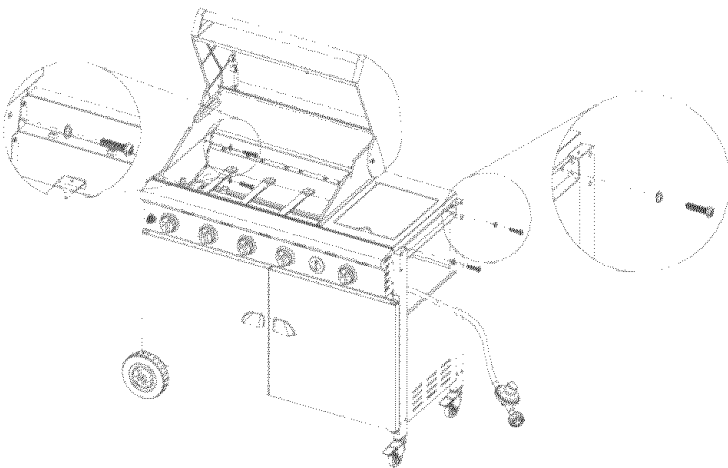

Figure 11

Installing Hose Retention Kit

1. Attach the regulator hose clamp and the regulator hose to the right front leg with (10) $\frac{1}{4}$ x $\frac{3}{5}$ " Phillips head screws and (1) $\frac{1}{4}$ " lock washer as below shown. (Fig. 13)

Installing Side Shelf

1. Attach right side shelf to cart leg using (4) $\frac{1}{4}$ x $\frac{3}{5}$ " Phillips head screws and (4) $\frac{1}{4}$ " lock washers. (Fig. 14)

2. Attach left side shelf to cart leg using (4) $\frac{1}{4}$ x $\frac{3}{5}$ " Phillips head screws and (4) $\frac{1}{4}$ " lock washers. See (Fig. 15)

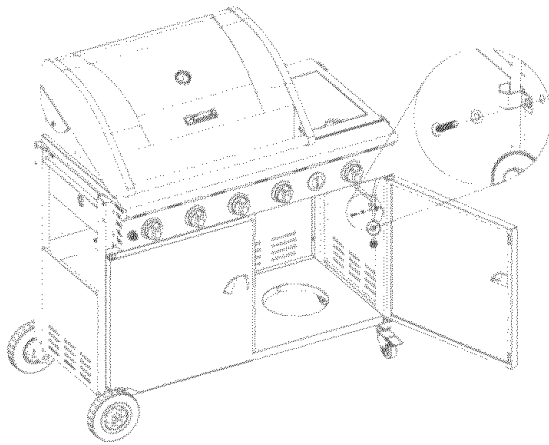

Figure 13

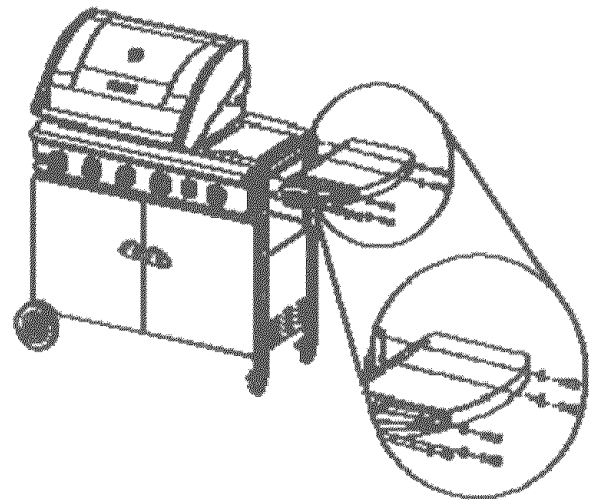

Figure 14

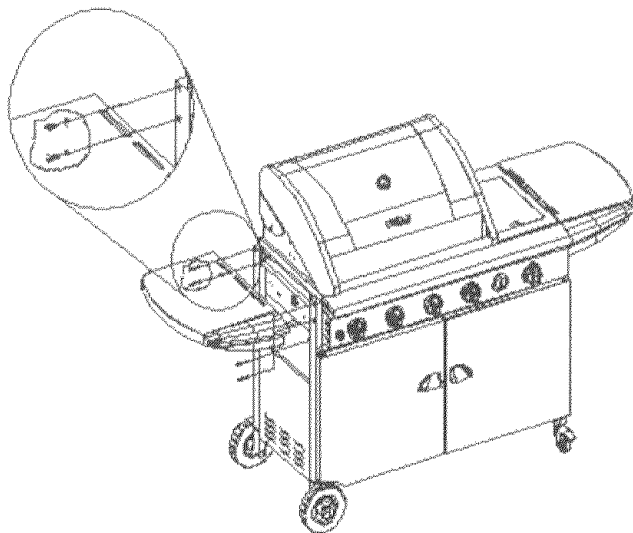

Figure 15

Install Grease Tray, Cooking Grids, and Flame Tamer.

1. Insert grease tray assembly into opening on backside of grill. Make sure to slide tray onto tracks as illustrated. (Fig 16)

When you have finished assembling grill, make sure that all screws and nuts are tight and secure.

Battery Assemble

1. Unscrew the ignition battery cap. (Found at far-left of control panel)

2. Insert battery into ignition box with positive terminal facing outward.

3. Replace the ignition battery cap after the battery has been installed. (Fig 17)

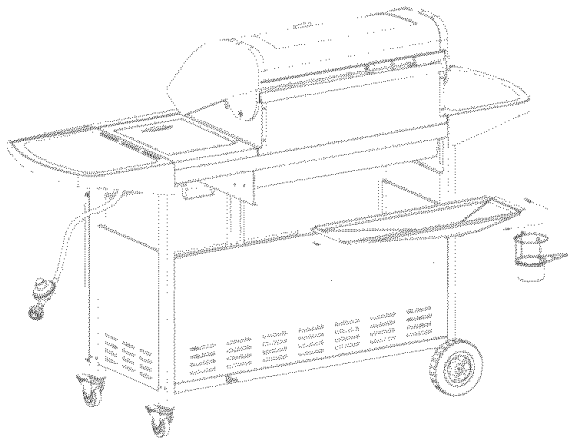

Figure 16

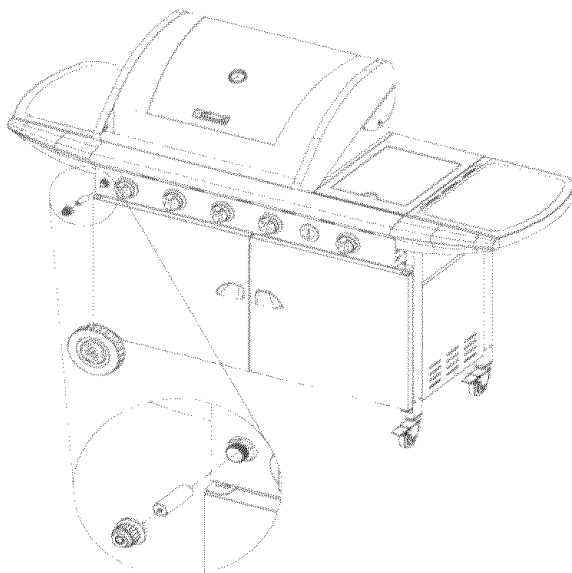

Figure 17

Installing cooking components

Important: Before cooking on your grill the first time, wash cooking grids and cooking rack with warm, soapy water. Rinse and dry thoroughly. Season with cooking oil regularly. After cooking is completed, turn grill to HIGH setting for 3 to 5 minutes to burn off excess grease or food residue.

1. Evenly space cooking grids on the ledge above flame tamers. (Fig. 18)
2. Place warming rack into the holes of the upper left and upper right of grill bowl side panels. (Fig. 18)

Connecting LP gas tank to LP grill

1. From Rear of the cart, place foot ring of 20 lb tank into the hole in bottom shelf. Make sure the tank valve is in OFF position. (Fig. 19)

2. Check the tank valve to ensure it has proper external mating threads to fit the hose and regulator assembly provided.

3. Make sure all burner valves are in OFF position.

4. Inspect the valve connection port and regulator assembly. Look for damage or debris. Remove any debris. Inspect hose for damage. Never use damaged or plugged equipment.

5. When connecting regulator and hose assembly to tank valve hand tighten quick coupling nut clockwise to a full stop. (Fig. 20) Do not use a wrench to tighten because it could damage the quick coupling nut and result in a hazardous condition.

6. Open tank valve fully (counterclockwise). Use a soapy water solution to check all connections for leaks before attempting to light your grill. If a leak is found, turn tank valve off and do not use your grill until the leak is repaired.

CAUTION: When the appliance is not in use, gas must be turned off at the supply tank.

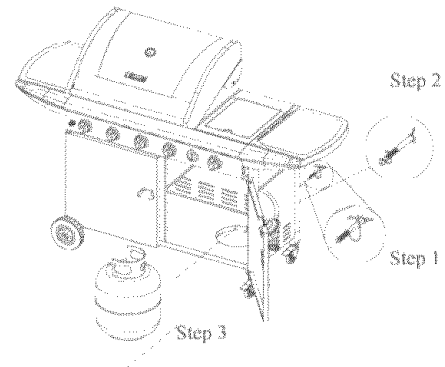

Figure 19

Regulator Connection

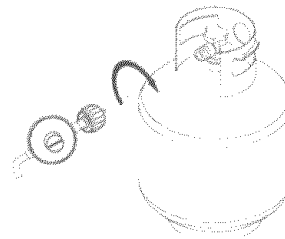

Figure 20

Congratulations

Your Kenmore gas grill is now ready for use. Before the first use and at the beginning of each season (and whenever the LP gas tank has been changed):

1. Read all safety, lighting and operating instructions.
2. Check gas valve orifices, burner tubes and burner ports for any obstructions.
3. Perform gas leak check according to instructions found on this page of the manual.

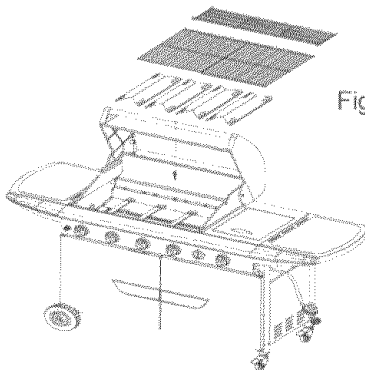

Figure 18

Checking for LP gas leaks

Never test for leaks with a flame. Prior to first use, at the beginning of each season, or every time your LP gas tank is changed, you must check for gas leaks.

1. Make a 50/50 mild soap solution
2. Turn the control knobs to full OFF position; then turn gas ON at supply tank.
3. Apply the soap solution with a clean brush to all gas connections. See below. If growing bubbles appear in the solution the connections are not properly sealed. Check each fitting and tighten or repair as necessary.

Gas Connection Leak Check

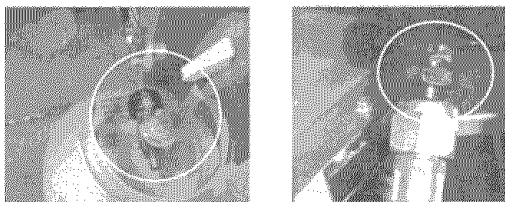

4. If you have a gas connection leak you cannot repair, turn gas OFF at supply tank, disconnect fuel line from your grill and call 1-800-4-MY-HOME or your gas supplier for repair assistance.

5. Also apply soapy solution to the tank seams. See below. If growing bubbles appear, shut tank OFF and do not use or move it! Contact an LP gas supplier or your fire department for assistance

Gas Tank Leak Check

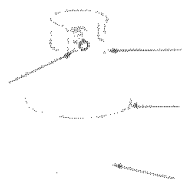

Grill Lighting Instruction

Basic Lighting Procedure

1. Familiarize yourself with the safety guidelines at the front of this manual. Do not smoke while lighting grill or checking gas supply connections.
2. Be sure the LP gas tank is sufficiently full.
3. Check that the end of each burner tube is properly located over each valve orifice.
4. Be sure all gas connections are securely tightened.
5. Open the grill main lid and side burner lid.



WARNING

Failure to open grill lid during the lighting procedure could result in a fire or explosion that could cause serious bodily injury, death, or property damage.

6. Push and turn one burner knob counterclockwise to "HI" position. Pilot torch will light. Hold at high setting for 3-4 seconds until burner is lit. After the burner is lit, adjust the knob to desired heat setting. Repeat this step to turn on additional burners.

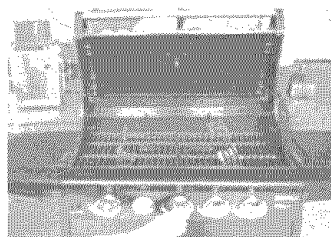

7. If the burner does not light after 3-4 seconds, turn control knob to "OFF" position. Then turn gas "OFF" at tank and wait 5 minutes for gas to clear. Then repeat step 6.
8. If lighting still doesn't occur, refer to If Grill Still Fails To Light on next page.

USING THE SIDE BURNER:

Inspect the gas supply hose prior to turning the gas "ON". If there is evidence of cuts, wear or abrasion, it must be replaced prior to use. Do not use the side burner if the odor of gas is present.

WARNING: Always keep your face and body as far away from the burner as possible when lighting.

LIGHTING INSTRUCTIONS FOR SIDE BURNER

1. Open side burner lid fully.
2. Remove any utensils from side burner grate.
3. Push and turn the burner knob counterclockwise to "HI" position. Hold at high setting for 3-4 seconds until burner is lit. After the burner is lit, adjust the knob to desired heat setting.
4. If the burner does not light after 3-4 seconds, turn control knob to "OFF" position. Then turn gas "OFF" at tank and wait 5 minutes for gas to clear. Then repeat step 3.
5. If lighting still doesn't occur, refer to If Grill Still Fails To Light on next page.

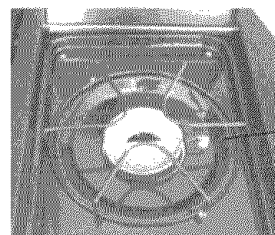

Approximate 1-1/2" Flame Height



WARNING

Never lean over the grill cooking area while lighting your gas grill. Keep your face and body a safe distance (at least 18 inches) from the cooking grid surface when lighting your grill by match.

Manually Lighting Your Grill by Match

1. Take the manual lighting stick
2. Insert a match into the lighting stick.
3. Follow steps 1 through 5 of the Basic Lighting Procedure.
4. Light the match and extend the lighting stick to cooking grid surface.
5. Turn the desired control knob to the HI/position setting to release gas. The burner should light immediately.

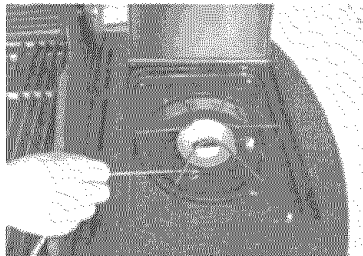
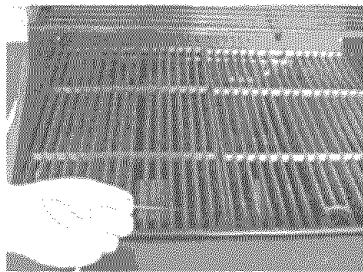

WARNING

Should a "FLASH-BACK" fire occur in/or around the burner tubes, follow the instructions below. Failure to comply with these instructions could result in a fire or explosion that could cause serious bodily injury, death, or property damage.

- Shut off gas supply to the gas grill.
- Turn the control knobs to OFF position.
- Put out any flame with a proper fire extinguisher.
- Open grill lid.
- Once the grill has cooled down, clean the burner tubes and burners according to the cleaning instructions found on page 17.

If Grill Still Fails To Light

1. Check gas supply and connections for leaks. Check that all wires connections are secure.

2. Repeat basic lighting procedure. If your grill still fails to operate, turn the gas off at source, turn the control knobs to OFF, then check the following:

- Misalignment of burner tubes over orifices
Correction: Reposition burner tubes over orifices.
- Obstruction in gas line
Correction: Remove fuel line from grill. Do not smoke! Open gas supply for 1 second to clear any obstruction from fuel line. Close off gas supply at source and reconnect fuel line to grill.
- Plugged orifice
Correction: Remove burners from grill, carefully lift each burner up and away from gas valve orifice. Remove the orifice from gas valve and gently clear any obstruction with a fine wire. Then reinstall all orifices, burners, and cooking components.

If an obstruction is suspected in gas valves, please call for repair service at 1-800-4-MY-HOME.

4. If the grill still does not light you may need to purge air from the gas line or reset the regulator excess gas flow device. **Note:** This procedure should be done every time a new LP gas tank is connected to your grill.

To purge air from your gas line and/or reset the regulator excess gas flow device:

- Turn the control knob to OFF position.
- Turn off the gas at the tank valve.
- Disconnect regulator from LP gas tank.
- Let unit stand for 5 minutes.
- Reconnect regulator to the LP gas tank.
- Turn the tank valve on slowly until $\frac{1}{4}$ to $\frac{1}{2}$ open.
- Open the grill lid.
- Set control knobs to OFF. Push and turn any control knob to HIGH.
- Turn control knobs to HIGH until all the burners are lit
- You may start to use the grill

5. If all checks or corrections have been made and you still have questions about operating your gas grill, call the **Customer Service Helpline 8am – 5pm EST, Monday through Friday at 1-800-913-8999**

Cleaning and Maintenance

To ensure a proper working unit the following proper care and maintenance is suggested.

Cleaning Cooking Grids

We suggest you wash your cooking grids in a mild soap and warm water solution. You can use a wash cloth or soft brush to clean your cooking grids.

Cleaning Flame Tamers

Periodically you should wash the flame tamers in a soap and warm water solution. Use a soft brush to remove stubborn burnt-on cooking residue. The flame tamers should be dry before you reinstall them.

Cleaning Grease Tray

The grease tray should be emptied and wiped down periodically and washed in a mild detergent and warm water solution. A small amount of sand or cat litter may be placed in bottom of grease tray to absorb the grease. Check the grease tray frequently, don't allow excess grease to accumulate and overflow out of the grease tray.

Annual Cleaning of Grill Interior

Burning-off the grill after every use will keep it ready for your next use. However, once a year you should give the entire grill a thorough cleaning to keep it in top operating condition. Follow these steps.

1. Turn all burner valves to full OFF position.
2. Turn LP gas tank valve to full OFF position.
3. Detach LP gas hose and regulator assembly from your gas grill. Inspect for any damage and replace as necessary with manufacturer replacement part number found on parts list.
4. Remove and clean flame tamers, cooking grids and grill burners.
5. Cover each gas valve orifice with aluminum foil.
6. Brush inside and bottom of grill with a nylon brush, and wash with a mild soap and warm water solution. Rinse thoroughly and let dry.
7. Reinstall flame tamers, cooking grids and grills.
8. Reconnect gas source and observe burner flame for correct operation.

Cleaning Exterior Surface

We suggest you wash your grill using a mild soap and warm water solution. You can use a wash cloth or sponge for this process. Do not use abrasives or a brush that might remove finish during the cleaning process.

Cleaning Exterior Stainless Steel Surfaces

Weathering and extreme heat can cause exterior stainless steel surfaces to turn tan in color. Machine oils used in manufacturing process of stainless steel can also cause this tanning color. Use a stainless steel cleaner to polish stainless steel surfaces of your grill. Never use abrasive cleaners or scrubbers because they will scratch and damage your grill.

Cleaning and Maintenance

Cleaning Burner Tubes and Burner Ports

To reduce the chance of "FLASH-BACK" the procedure below should be followed at least once a month in late summer or early fall when spiders are most active or when your grill has not been used for a period of time.

1. Turn all burner valves and gas tank valve to off position.
2. Detach the LP gas regulator assembly from your gas grill.
3. Remove cooking grids, flame tamers, and grease tray from the grill.
4. Remove the screws from the underside of each burner and lift the burners up and away from the gas valve orifice.
5. Using a bent stiff wire in the shape of a hook, air hose or a bottle brush, run it through the burner tube and inside several times to remove any debris.
6. Replace burners, see illustration below.

Step 1. Locate the burner onto the orifice.

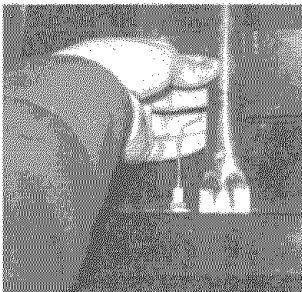

Step 2. Secure the main burner on the back wall of fire box with 2 screws.

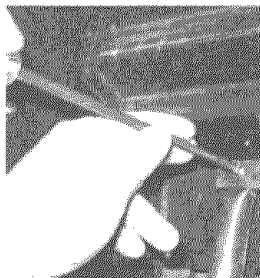

WARNING

The location of the burner tube with respect to the orifice is vital for safe operation. Check to ensure the orifice is inside the burner tube before using the gas grill. If the burner tube does not fit over the valve orifice, lighting the burner may cause explosion and/or fire.

Regardless of which burner cleaning procedure you use, we recommend you also complete the following steps to help prolong burner life.

1. Use a fiber pad or nylon brush to clean the entire outer surface of each burner until free of food residue and dirt.
2. Clean any clogged ports with a stiff wire, such as an open paper clip.
3. Inspect each burner for damage (cracks or holes) and if such damage is found, order and install a new burner. After installation check to ensure that gas valve orifices are correctly placed inside the ends of the burner tubes.

TROUBLESHOOTING

BEFORE CALLING FOR SERVICE

If the grill does not function properly, use the following check list before calling for service.

You should inspect the burners at least once a year or immediately after any of the following conditions occur:

PROBLEMS	WHAT TO DO
Grill won't light when the control knob is rotated.	<p>Check to see if LP tank is empty.</p> <p>Clean wires and/or electrode by rubbing with alcohol and clean swab.</p> <p>Wipe with dry cloth.</p> <p>Make sure the wire is connected to electrode assembly.</p> <p>Do other burners on the unit operate?</p> <p>Check to see if other burners operate. If so, check the gas orifice on the malfunctioning burner for an obstruction.</p>
Burner flame is yellow or orange, in combination with the odor of gas.	Refer to Clean Burner Tubes and Burner Ports on page 17. If problem still exist, please call 1-800-My-Home.
Low heat with knob in "Hi" position.	<p>Is the fuel hose bent or kinked?</p> <p>Is the grill in a dusty area?</p> <p>Is there adequate gas supply available?</p> <p>If it is only one burner that appears low, does the orifice or burner need cleaning?</p> <p>Is the gas supply or gas pressure low?</p>

Cooking Instructions



WARNING

Do not leave the grill unattended. Your grill will get very hot. Never lean over the cooking area while using your grill. Do not touch cooking surfaces, grill housing, Grill Lid or any other grill parts while the grill is in operation, or until the grill has cooled down after use. Failure to comply with these instructions may result in serious bodily injury.

Burn-off

Before cooking on your gas grill for the first time, you will want to "burn off" the grill to eliminate any odor or foreign matter. Just ignite the burners, lower the Lid, and operate grill on the HIGH setting for 3 to 5 minutes.

Cooking Temperatures

High setting: Only use this setting for fast warm-up, searing steaks or chops and for burning food residue off the grill after cooking is complete. **Never** use the HIGH setting for extended cooking.

Medium to Low Settings: Most recipes specify medium to low settings, including all smoking, rotisserie cooking and for cooking lean cuts such as fish.

NOTE: Temperature settings will vary with the temperature and the amount of wind outside your home.

Direct Cooking

The direct cooking method can be used with the supplied cooking grids and food placed directly over the lit grill Burners. **Direct cooking requires the grill lid to be up.** The method is ideal for searing and whenever you want meat, poultry or fish to have an open-flame barbecued taste. Deep frying and smoking are also best cooked in this manner because they require direct heat.

Indirect Cooking

To cook **indirectly**, the food should be placed on the left or right side of your grill with the burner lit on the opposite side. **Indirect cooking must be done with the Lid down.**

Flare-ups

The fats and juices dripping from grilled food can cause flare-ups. Since flare-ups impart a favorably distinctive taste and color to food cooked over an open flame, they should be accepted up to a point. Nevertheless, uncontrolled flaring can result in a ruined meal.



WARNING

Do not line the bottom of the grill housing with aluminum foil, sand or any substance that will restrict the flow of grease into the grease tray. Failure to comply with these instructions could result in a fire or explosion which could cause serious bodily injury, death, or property damage.

GRILL COOKING CHART

FOOD	Weight or thickness	Temperature	Time	Special instructions and tips
Vegetables	NA	Medium	8 to 20 minutes	Slice or chop vegetables and dot with butter or margarine. Wrap tightly in heavy duty foil. Grill turning occasionally.
Potatoes	Whole	Medium	40 to 60 minutes	Wrap individually in heavy duty foil. Cook rotating occasionally.
Meat/Steaks	1/2 to 3/4 inches	High-Medium	4 to 15 minutes	Pre heat grill for 15-20 minutes then sear steaks on each side for two minutes. Next grill 3 to 5 minutes on each side or until desired doneness.
Ground Meats	1/2 to 3/4 inches	Medium	8 to 15 minutes	Grill turning once when juices rise to the surface or until desired amount of doneness. Do not leave hamburgers unattended since a flare-up could occur quickly.
Ribs	1/2 or full rack	Medium	20 to 40 minutes	Grill turning occasionally. During last few minutes brush with barbecue sauce, turn several times.
Hot dogs	NA	Medium	5 to 10 minutes	Grill turning four times. 2-4 minutes on each of four sides.
Poultry-Cut	1/4 to 1/2 pounds	Low or Medium	20 to 40 minutes	Grill turning occasionally. During last few minutes brush with barbecue sauce if desired, turn several times.
Poultry Whole	2 to 3 pounds	Low or	1 to 1-1/2 hours	Use poultry stand and brush frequently as desired
		Medium	40 to 60 minutes	Use poultry stand and brush frequently as desired
Fish	3/4 to 1 inch	Medium	8 to 15 minutes	Grill turning once to desired doneness. Brush with melted butter, margarine or oil.

Get it fixed, at your home or ours!

Your Home

For repair – **in your home** – of all major brand appliances, lawn and garden equipment, or heating and cooling systems, **no matter who made it, no matter who sold it!**

For the replacement parts, accessories and owner's manuals that you need to do-it-yourself.

For Sears professional installation of home appliances and items like garage door openers and water heaters.

1-800-4-MY-HOME® (1-800-469-4663)

Call anytime, day or night (U.S.A. and Canada)

www.sears.com www.sears.ca

Our Home

For repair of carry-in items like vacuums, lawn equipment, and electronics, call or go on-line for the location of your nearest

Sears Parts & Repair Service Center

1-800-488-1222

Call anytime, day or night (U.S.A. only)

www.sears.com

To purchase a protection agreement (U.S.A.) or maintenance agreement (Canada) on a product serviced by Sears:

1-800-827-6655 (U.S.A.)

1-800-361-6665 (Canada)

Para pedir servicio de reparación a domicilio, y para ordenar piezas:

1-888-SU-HOGAR®

(1-888-784-6427)

Au Canada pour service en français:

1-800-LE-FOYER^{MC}

(1-800-533-6937)

www.sears.ca

The Sears logo is displayed in a stylized, bold, serif font. The word "Sears" is written in a dark color, with a horizontal line underneath the letters "e" and "a".

® Registered Trademark / TM Trademark / SM Service Mark of Sears Brands, LLC
© Marca Registrada / TM Marca de Fábrica / SM Marca de Servicio de Sears Brands, LLC
MC Marque de commerce / MP Marque déposée de Sears Brands, LLC

© Sears Brands, LLC