

SEARS

GENERAL MANUAL

CRAFTSMAN[®]

OIL LUBRICATED STATIONARY AIR COMPRESSORS

- SAFETY GUIDELINES
- ASSEMBLY
- OPERATION
- MAINTENANCE
- TROUBLESHOOTING

IMPORTANT:
Read the Safety Guidelines and
All Instructions Carefully Be-
fore Operating.

Record in the spaces provided.

- (1) The model number which can be found on the maintenance label on the front of the air tank.
- (2) The code number which can be found on the foil label on the right side of the air tank.
- (3) The Manufacturers Number (Mfg. No.) (ASME code compressors only) is located on the metal data plate which is welded onto the left side of the air tank. (This data plate is painted the same color as the tank.)

Retain these numbers for future
reference.

Model No. _____

Code No. _____

Mfg. No. _____

Sears, Roebuck and Co., Hoffman Estates, IL 60179 U.S.A.

TABLE OF CONTENTS

	Page		Page
SAFETY GUIDELINES-GUIDELINES	2	OPERATING PROCEDURES	12
SAFETY GUIDELINES	3	MAINTENANCE	13
SPECIFICATIONS	6	Routine Maintenance Schedule	13
ON-RECEIPT INSPECTION	6	SERVICE INSTRUCTIONS	14-16
GENERAL INFORMATION	6	Air Filter-Inspection and Replacement	14
GLOSSARY	7	Oil-Checking and Changing	14
DESCRIPTION OF OPERATION	7	Two Stage Units	14
INSTALLATION AND		Check Valve-Inspection and Replacement	14
BREAK-IN PROCEDURES	8-11	Safety Valve-Inspection and Replacement	15
Location of Air Compressor	8	Belt-Replacement	15
Air Compressor Anchoring Methods	8	Adjusting Belt Tension	15
Wiring Instructions	9	Motor Pulley and Flywheel Alignment	16
Voltage and Circuit Protection	9	Motor Overload Protector-Reset	16
Wiring Diagram	9	Motor Lubrication	16
Piping	10	Compressor Head Bolts-Torquing	16
Additional Regulators and Controls	11	Additional Service	16
Lubrication and Oil	11	TROUBLESHOOTING GUIDE	17-20
Break-in Procedures	11	HOW TO ORDER REPAIR PARTS	back cover

SAFETY GUIDELINES - DEFINITIONS

This manual contains information that is important for you to know and understand. This information relates to protecting **YOUR SAFETY** and **PREVENTING EQUIPMENT PROBLEMS**. To help you recognize this information, we use the symbols to the right. Please read the manual and pay attention to these sections.

▲ DANGER

DANGER indicates an imminently hazardous situation which, if not avoided, will result in death or serious injury.

▲ CAUTION

CAUTION indicates a potentially hazardous situation which, if not avoided, may result in minor or moderate injury.

▲ WARNING

WARNING indicates a potentially hazardous situation which, if not avoided, could result in death of serious injury.

CAUTION

CAUTION used without the safety alert symbol indicates a potentially hazardous situation which, if not avoided, may result in property damage.

IMPORTANT SAFETY INSTRUCTIONS



SAVE THESE INSTRUCTIONS



WARNING

IMPROPER OPERATION OR MAINTENANCE OF THIS PRODUCT COULD RESULT IN SERIOUS INJURY AND PROPERTY DAMAGE. READ AND UNDERSTAND ALL WARNINGS AND OPERATING INSTRUCTIONS BEFORE USING THIS EQUIPMENT.

HAZARD

RISK OF EXPLOSION OR FIRE



WHAT CAN HAPPEN	HOW TO PREVENT IT
<p>IT IS NORMAL FOR ELECTRICAL CONTACTS WITHIN THE MOTOR AND PRESSURE SWITCH TO SPARK.</p> <p>IF ELECTRICAL SPARKS FROM COMPRESSOR COME INTO CONTACT WITH FLAMMABLE VAPORS, THEY MAY IGNITE, CAUSING FIRE OR EXPLOSION.</p> <p>RESTRICTING ANY OF THE COMPRESSOR VENTILATION OPENINGS WILL CAUSE SERIOUS OVERHEATING AND COULD CAUSE FIRE.</p>	<p>ALWAYS OPERATE THE COMPRESSOR IN A WELL VENTILATED AREA FREE OF COMBUSTIBLE MATERIALS, GASOLINE OR SOLVENT VAPORS.</p> <p>IF SPRAYING FLAMMABLE MATERIALS, LOCATE COMPRESSOR AT LEAST 20 FEET AWAY FROM SPRAY AREA. AN ADDITIONAL LENGTH OF HOSE MAY BE REQUIRED.</p> <p>STORE FLAMMABLE MATERIALS IN A SECURE LOCATION AWAY FROM COMPRESSOR.</p> <p>NEVER PLACE OBJECTS AGAINST OR ON TOP OF COMPRESSOR. OPERATE COMPRESSOR IN AN OPEN AREA AT LEAST 12 INCHES AWAY FROM ANY WALL OR OBSTRUCTION THAT WOULD RESTRICT THE FLOW OF FRESH AIR TO THE VENTILATION OPENINGS.</p> <p>OPERATE COMPRESSOR IN A CLEAN, DRY, WELL VENTILATED AREA. DO NOT OPERATE UNIT INDOORS OR IN ANY CONFINED AREA.</p>
<p>UNATTENDED OPERATION OF THIS PRODUCT COULD RESULT IN PERSONAL INJURY OR PROPERTY DAMAGE.</p>	<p>ALWAYS REMAIN IN ATTENDANCE WITH THE PRODUCT WHEN IT IS OPERATING.</p>

RISK OF BURSTING



AIR TANK: THE FOLLOWING CONDITIONS COULD LEAD TO A WEAKENING OF THE TANK, AND RESULT IN A VIOLENT TANK EXPLOSION AND COULD CAUSE PROPERTY DAMAGE OR SERIOUS INJURY.

WHAT CAN HAPPEN	HOW TO PREVENT IT
<ol style="list-style-type: none"> FAILURE TO PROPERLY DRAIN CONDENSED WATER FROM THE TANK, CAUSING RUST AND THINNING OF THE STEEL TANK. MODIFICATIONS OR ATTEMPTED REPAIRS TO THE TANK. UNAUTHORIZED MODIFICATIONS TO THE UNLOADER VALVE, SAFETY VALVE, OR ANY OTHER COMPONENTS WHICH CONTROL TANK PRESSURE. EXCESSIVE VIBRATION CAN WEAKEN THE AIR TANK AND CAUSE RUPTURE OR EXPLOSION. <p>ATTACHMENTS & ACCESSORIES:</p> <p>EXCEEDING THE PRESSURE RATING OF AIR TOOLS, SPRAY GUNS, AIR OPERATED ACCESSORIES, TIRES AND OTHER INFLATABLES CAN CAUSE THEM TO EXPLODE OR FLY APART, AND COULD RESULT IN SERIOUS INJURY.</p>	<p>DRAIN TANK DAILY OR AFTER EACH USE. IF TANK DEVELOPS A LEAK, REPLACE IT IMMEDIATELY WITH A NEW TANK OR REPLACE THE ENTIRE COMPRESSOR.</p> <p>NEVER DRILL INTO, WELD, OR MAKE ANY MODIFICATIONS TO THE TANK OR ITS ATTACHMENTS.</p> <p>THE TANK IS DESIGNED TO WITHSTAND SPECIFIC OPERATING PRESSURES. NEVER MAKE ADJUSTMENTS OR PARTS SUBSTITUTIONS TO ALTER THE FACTORY SET OPERATING PRESSURES.</p> <p>FOR ESSENTIAL CONTROL OF AIR PRESSURE, YOU MUST INSTALL A PRESSURE REGULATOR AND PRESSURE GAUGE TO THE AIR OUTLET OF YOUR COMPRESSOR. FOLLOW THE EQUIPMENT MANUFACTURERS RECOMMENDATION AND NEVER EXCEED THE MAXIMUM ALLOWABLE PRESSURE RATING OF ATTACHMENTS. NEVER USE COMPRESSOR TO INFLATE SMALL LOW-PRESSURE OBJECTS SUCH AS CHILDREN'S TOYS, FOOTBALLS, BASKETBALLS, ETC.</p>

HAZARD

RISK FROM FLYING OBJECTS



WHAT CAN HAPPEN	HOW TO PREVENT IT
<p>THE COMPRESSED AIR STREAM CAN CAUSE SOFT TISSUE DAMAGE TO EXPOSED SKIN AND CAN PROPEL DIRT, CHIPS, LOOSE PARTICLES AND SMALL OBJECTS AT HIGH SPEED, RESULTING IN PROPERTY DAMAGE OR PERSONAL INJURY.</p>	<p>ALWAYS WEAR ANSI Z87.1 APPROVED SAFETY GLASSES WITH SIDE SHIELDS WHEN USING THE COMPRESSOR.</p> <p>NEVER POINT ANY NOZZLE OR SPRAYER TOWARD ANY PART OF THE BODY OR AT OTHER PEOPLE OR ANIMALS.</p> <p>ALWAYS TURN THE COMPRESSOR OFF AND BLEED PRESSURE FROM THE AIR HOSE AND TANK BEFORE ATTEMPTING MAINTENANCE, ATTACHING TOOLS OR ACCESSORIES.</p>

RISK TO BREATHING

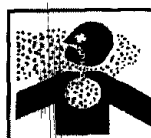

WHAT CAN HAPPEN	HOW TO PREVENT IT
<p>THE COMPRESSED AIR FROM YOUR COMPRESSOR IS NOT SAFE FOR BREATHING! THE AIR STREAM MAY CONTAIN CARBON MONOXIDE, TOXIC VAPORS OR SOLID PARTICLES FROM THE TANK.</p> <p>SPRAYED MATERIALS SUCH AS PAINT, PAINT SOLVENTS, PAINT REMOVER, INSECTICIDES, WEED KILLERS, CONTAIN HARMFUL VAPORS AND POISONS.</p>	<p>ALWAYS OPERATE AIR COMPRESSOR OUTSIDE IN A CLEAN, WELL VENTILATED AREA. AVOID ENCLOSED AREAS SUCH AS GARAGES, BASEMENTS, STORAGE SHEDS, WHICH LACK A STEADY EXCHANGE OF AIR. KEEP CHILDREN, PETS AND OTHERS AWAY FROM AREA OF OPERATION.</p> <p>NEVER INHALE AIR FROM THE COMPRESSOR EITHER DIRECTLY OR FROM A BREATHING DEVICE CONNECTED TO THE COMPRESSOR.</p> <p>WORK IN AN AREA WITH GOOD CROSS-VENTILATION. READ AND FOLLOW THE SAFETY INSTRUCTIONS PROVIDED ON THE LABEL OR SAFETY DATA SHEETS FOR THE MATERIAL YOU ARE SPRAYING. USE A NIOSH/MSHA APPROVED RESPIRATOR DESIGNED FOR USE WITH YOUR SPECIFIC APPLICATION.</p>

RISK OF ELECTRICAL SHOCK



WHAT CAN HAPPEN	HOW TO PREVENT IT
<p>YOUR AIR COMPRESSOR IS POWERED BY ELECTRICITY. LIKE ANY OTHER ELECTRICALLY POWERED DEVICE, IF IT IS NOT USED PROPERLY IT MAY CAUSE ELECTRIC SHOCK.</p> <p>REPAIRS ATTEMPTED BY UNQUALIFIED PERSONNEL CAN RESULT IN SERIOUS INJURY OR DEATH BY ELECTROCUTION.</p> <p>ELECTRICAL GROUNDING: FAILURE TO PROVIDE ADEQUATE GROUNDING TO THIS PRODUCT COULD RESULT IN SERIOUS INJURY OR DEATH FROM ELECTROCUTION. SEE GROUNDING INSTRUCTIONS.</p>	<p>NEVER OPERATE THE COMPRESSOR OUTDOORS WHEN IT IS RAINING OR IN WET CONDITIONS.</p> <p>NEVER OPERATE COMPRESSOR WITH COVER COMPONENTS REMOVED OR DAMAGED.</p> <p>ANY ELECTRICAL WIRING OR REPAIRS REQUIRED ON THIS PRODUCT SHOULD BE PERFORMED BY AUTHORIZED SERVICE CENTER PERSONNEL IN ACCORDANCE WITH NATIONAL AND LOCAL ELECTRICAL CODES.</p> <p>MAKE CERTAIN THAT THE ELECTRICAL CIRCUIT TO WHICH THE COMPRESSOR IS CONNECTED PROVIDES PROPER ELECTRICAL GROUNDING, CORRECT VOLTAGE AND ADEQUATE FUSE PROTECTION.</p>

HAZARD

RISK FROM MOVING PARTS

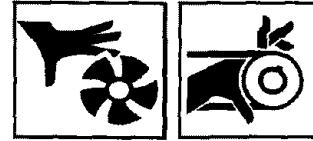

WHAT CAN HAPPEN	HOW TO PREVENT IT
<p>MOVING PARTS SUCH AS THE PULLEY, FLYWHEEL AND BELT CAN CAUSE SERIOUS INJURY IF THEY COME INTO CONTACT WITH YOU OR YOUR CLOTHING.</p> <p>ATTEMPTING TO OPERATE COMPRESSOR WITH DAMAGED OR MISSING PARTS OR ATTEMPTING TO REPAIR COMPRESSOR WITH PROTECTIVE SHROUDS REMOVED CAN EXPOSE YOU TO MOVING PARTS AND CAN RESULT IN SERIOUS INJURY.</p>	<p>NEVER OPERATE THE COMPRESSOR WITH GUARDS OR COVERS WHICH ARE DAMAGED OR REMOVED.</p> <p>ANY REPAIRS REQUIRED ON THIS PRODUCT SHOULD BE PERFORMED BY AUTHORIZED SERVICE CENTER PERSONNEL.</p>

RISK OF BURNS



WHAT CAN HAPPEN	HOW TO PREVENT IT
<p>TOUCHING EXPOSED METAL SUCH AS THE COMPRESSOR HEAD OR OUTLET TUBES, CAN RESULT IN SERIOUS BURNS.</p>	<p>NEVER TOUCH ANY EXPOSED METAL PARTS ON COMPRESSOR DURING OR IMMEDIATELY AFTER OPERATION. COMPRESSOR WILL REMAIN HOT FOR SEVERAL MINUTES AFTER OPERATION.</p> <p>DO NOT REACH AROUND PROTECTIVE SHROUDS OR ATTEMPT MAINTENANCE UNTIL UNIT HAS BEEN ALLOWED TO COOL.</p>

RISK OF FALLING



WHAT CAN HAPPEN	HOW TO PREVENT IT
<p>A PORTABLE COMPRESSOR CAN FALL FROM A TABLE, WORKBENCH OR ROOF CAUSING DAMAGE TO THE COMPRESSOR AND COULD RESULT IN SERIOUS INJURY OR DEATH TO THE OPERATOR.</p>	<p>ALWAYS OPERATE COMPRESSOR IN A STABLE SECURE POSITION TO PREVENT ACCIDENTAL MOVEMENT OF THE UNIT. NEVER OPERATE COMPRESSOR ON A ROOF OR OTHER ELEVATED POSITION. USE ADDITIONAL AIR HOSE TO REACH HIGH LOCATIONS.</p>

RISK OF PROPERTY DAMAGE WHEN TRANSPORTING COMPRESSOR (Fire, Inhalation, Damage to Vehicle Surfaces)



WHAT CAN HAPPEN	HOW TO PREVENT IT
<p>OIL CAN LEAK OR SPILL AND COULD RESULT IN FIRE OR BREATHING HAZARD, SERIOUS INJURY OR DEATH CAN RESULT. OIL LEAKS WILL DAMAGE CARPET, PAINT OR OTHER SURFACES IN VEHICLES OR TRAILERS.</p>	<p>ALWAYS PLACE COMPRESSOR ON A PROTECTIVE MAT WHEN TRANSPORTING TO PROTECT AGAINST DAMAGE TO VEHICLE FROM LEAKS. REMOVE COMPRESSOR FROM VEHICLE IMMEDIATELY UPON ARRIVAL AT YOUR DESTINATION.</p>

SPECIFICATIONS

Refer to Outfit Parts Bulletin for the specifications of your compressor. Use only a fuse or circuit breaker that is the same rating as the branch circuit the air compressor is operated on. If the compressor is connected to a circuit protected by fuses, use dual element time delay fuses, as noted in that service bulletin.

ON-RECEIPT INSPECTION

Note

Each air compressor outfit is carefully checked before shipment. With improper handling, damage may result in transit and cause problems in compressor operation.

Immediately upon arrival, check equipment for both concealed and visible damages to avoid expenses being incurred to correct such problems. This should be done regardless of any visible signs of damage to the shipping container. Report any damages to carrier and arrange for inspection of goods immediately.

1. Check for damaged belt guard.
2. If belt guard or drive shows damage, remove guard and turn the flywheel by hand to ensure crankshaft has not been bent in shipping and that the belt drive is properly aligned and free of any distortion.
3. Check for damaged air tank and attached legs.
4. Inspect compressor outfit for possible damaged or missing components.

GENERAL INFORMATION

You have purchased a complete compressor outfit consisting of an air compressor, air tank, electric motor, and associated controls and instruments. The outfit you have selected is a stationary model and contains either a single stage or two stage air compressor pump.

Your new compressor outfit can be used for operating paint sprayers, air tools, grease guns, air brushes, caulking guns, sandblasters, inflating tires, etc.

An air pressure regulator is usually necessary for most applications. An air line filter is normally required for removal of moisture and oil vapor in compressed air when a paint spray gun is used.

An in-line lubricator is often required for air tools to prolong tool life.

Separate air transformers which combine the functions of air regulation and/or moisture and dirt removal should be used where applicable.

A regularly scheduled program of preventive maintenance will help provide the long life that has been designed into your compressor outfit. Before operating or performing any maintenance on your compressor, refer to this manual and your Outfit Parts Bulletin. To keep your compressor in good working order, refer to these publications often and perform preventive maintenance steps as recommended.

GLOSSARY

CFM: Cubic feet per minute.

SCFM: Standard cubic feet per minute; a unit of measure of air delivery.

PSIG: Pounds per square inch gauge; a unit of measure of pressure.

ASME: American Society of Mechanical Engineers; made, tested, inspected and registered to meet the standards of the ASME.

Cut-In Pressure: While the motor is off, air tank pressure drops as you continue to use your accessory.

When the tank pressure drops to a certain low level the motor will restart automatically. The low pressure at which the motor automatically re-starts is called "cut-in pressure."

Cut-Out Pressure: When you turn on your air compressor and it begins to run, air pressure in the air tank begins to build. It builds to a certain high pressure before the motor automatically shuts off - protecting your air tank from pressure higher than its capacity. The high pressure at which the motor shuts off is called "cut-out pressure."

To Lock Out Power: Place a lock on the line power switch so no one else can turn on the power.

DESCRIPTION OF OPERATION

Drain Valve: At the base of the air tank to drain condensation at the end of each use.

Motor Thermal Overload Protector: The electric motor has an automatic thermal overload protector. If the motor overheats for any reason, the thermal overload protector will shut off the motor. The motor must be allowed to cool down before restarting.

ON/AUTO-OFF Switch: Turn this switch ON to provide automatic power to the pressure switch and OFF to remove power.

Air Intake Filter: This filter is designed to clean air coming into the pump. This filter must always be clean and ventilation openings free from obstructions. See "Maintenance".

Air Compressor Pump: To compress air, the piston moves up and down in the cylinder. On the down-stroke, air is drawn in through the air intake valves. The exhaust valve remains closed. On the upstroke of the piston, air is compressed. The intake valves close and compressed air is forced out through the exhaust valve, through the outlet tube, through the check valve and into the air tank. Working air is not available until the compressor has raised the air tank pressure above that required at the air outlet.

In two stage compressors, air is first compressed to an intermediate pressure in the large bore cylinder, and after passing through an inter-cooler, the air is further compressed to a higher pressure in the smaller bore cylinder. This process continues until the air tank pressure reaches the factory set cutoff pressure. At that point the pressure switch shuts the electric motor off.

Check Valve: When the air compressor is operating, the check valve is "open", allowing compressed air to enter the air tank. When the air compressor reaches "cut-out" pressure, the check valve "closes", allowing air pressure to remain inside the air tank.

Pressure Release Valve: The pressure release valve located on the side of the pressure switch, is designed to automatically release compressed air from the compressor head and the outlet tube when the air compressor reaches "cut-out" pressure or is shut off. If the air is not released, the motor will try to start, but will be unable to. The pressure release valve allows the motor to restart freely. When the motor stops running, air will be heard escaping from the valve for a few seconds. No air should be heard leaking when the motor is running.

Pressure Switch: The pressure switch automatically starts the motor when the air tank pressure drops below the factory set "cut-in" pressure. It stops the motor when the air tank pressure reaches the factory set "cut-out" pressure.

Shut-off Valve: Turn the knob counterclockwise to open the valve and clockwise to close.

Air Tank Safety Valve: If the pressure switch does not shut off the air compressor at its cut-out pressure setting, the safety valve will protect against high pressure by "popping off" at its factory set pressure (slightly higher than the pressure switch cut-out setting).

Aftercooler Safety Valve: On two stage compressor units, safety valve is provided to prevent over-pressurization of the aftercooler. The valve will protect the aftercooler by "popping off" at its factory set pressure.

Regulator: An air pressure regulator or a separate air transformer which combines the functions of air regulation and/or moisture and dirt removal is required for most applications.

Tank Pressure Gauge: The tank pressure gauge indicates the reserve air pressure in the tank. On outfits with no pressure regulator, this is also the pressure available at the air outlet.

INSTALLATION AND BREAK-IN PROCEDURES

Location of the Air Compressor

⚠ CAUTION

THE MANIFOLD ASSEMBLY DOES NOT PROVIDE ADEQUATE STABILITY OR SUPPORT FOR LIFTING THE UNIT. IF THE OUTFIT MUST BE MOVED, USE THE TANK FOR LIFTING.

This compressor should be permanently mounted in place on a level floor. Operate the air compressor in a clean, dry and well ventilated area. The air intake filter must be kept clear of obstructions which could reduce air delivery of the air compressor. The air compressor should be located at least 12" away from walls or other obstructions that could interfere with the flow of air through the fan bladed flywheel. The air compressor crankcase and head are designed with fins to provide proper cooling.

The flywheel side of the outfit should be placed toward the wall and protected with a totally enclosed belt guard. In no case should the flywheel be closer than 12 to 18 inches from the wall or other obstruction that will interfere with the flow of air through the fan bladed flywheel. The area should allow space on all sides for air circulation and for ease of normal maintenance. Keep the outfit away from areas which have dirt, vapor and volatile fumes in the atmosphere which may clog and gum the intake filter and valves, causing inefficient operation. Where this is not practical a remote air intake is recommended.

Note

Where a remote air intake is used, enlarge the size of the air intake piping by one pipe size for each 10 feet of length.

If humidity is high, an air filter can be installed to remove excessive moisture. Closely follow instructions packaged with the filter for proper installation. It must be installed as close as possible to the accessory.

The air compressor should be as near to air outlets as possible in order to avoid long pipe lines. Do not place the air compressor where heat is excessive.

Air Compressor Anchoring Methods

⚠ WARNING

VIBRATION CAN WEAKEN THE AIR TANK AND CAUSE AN EXPLOSION. THE COMPRESSOR MUST BE PROPERLY MOUNTED AS ILLUSTRATED BELOW.

Vertical Units

Vertical air compressors must be bolted to the floor. Bolting holes are provided in the base feet. Mount the air compressor on a solid, level foundation. Support compressor weight evenly on all four feet. Solid shims may be used if necessary.

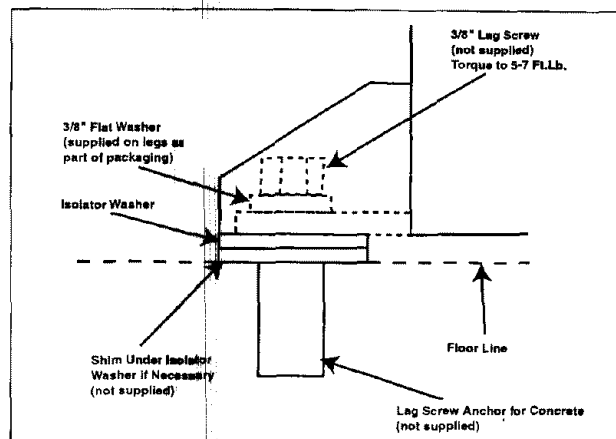

Anchoring of Vertical Unit

Horizontal Units

Some tank mounted compressor outfits are shipped with (4) rubber isolator pads. When installing compressor in its working location, one isolator pad is to be placed under each foot. The floor must be smooth and level. The compressor should sit square on all four feet. Install shims as needed to support compressor weight evenly on all four feet. The horizontal type compressor is not required to be bolted or lagged to the floor.

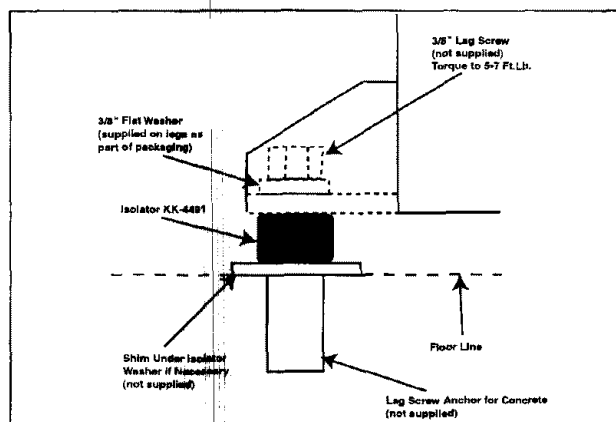

Anchoring of Horizontal Unit

INSTALLATION AND BREAK-IN PROCEDURES

Wiring Instructions

If your compressor unit is not equipped with a plug-in type power cord, perform electrical wiring according to the following instructions:

⚠ DANGER

IMPROPER ELECTRICAL GROUNDING CAN RESULT IN A RISK OF ELECTRICAL SHOCK. WIRING FOR THE PRESSURE SWITCH AND ELECTRICAL MOTOR SHOULD BE DONE BY A LICENSED ELECTRICIAN IN ACCORDANCE WITH NATIONAL AND LOCAL CODES AND ORDINANCES.

Install the compressor outfit as close to the main power supply as possible. This practice will avoid using long lengths of electrical wiring for the power supply which can cause power loss to the motor. When connecting wires make sure that:

1. The amperage rating of the electrical box is adequate. Refer to the Specification Chart in the Outfit Parts Bulletin for your air compressor outfit.
2. The supply line has the same electrical characteristics (voltage, cycle, and phase) as motor.

Wiring must be such that full motor nameplate voltage plus or minus 10%, is available at the motor terminals during starting. Refer to local codes for recommended wire sizes for correct wire size and maximum wire run; undersize wire causes high amp draw and overheating to the motor.

⚠ CAUTION

Electrical wiring must be located away from hot surfaces such as the compressor head, compressor cylinder, or compressor outlet tube.

Voltage and Circuit Protection

Refer to your Outfit Parts Bulletin for the voltage and circuit protection requirements of your compressor. Use only a fuse or circuit breaker that is the same rating as the branch circuit the air compressor is operated on. If the compressor is connected to a circuit protected by fuses, use only dual element time delay fuses, as noted in that Service Bulletin.

Wiring of Compressor Units

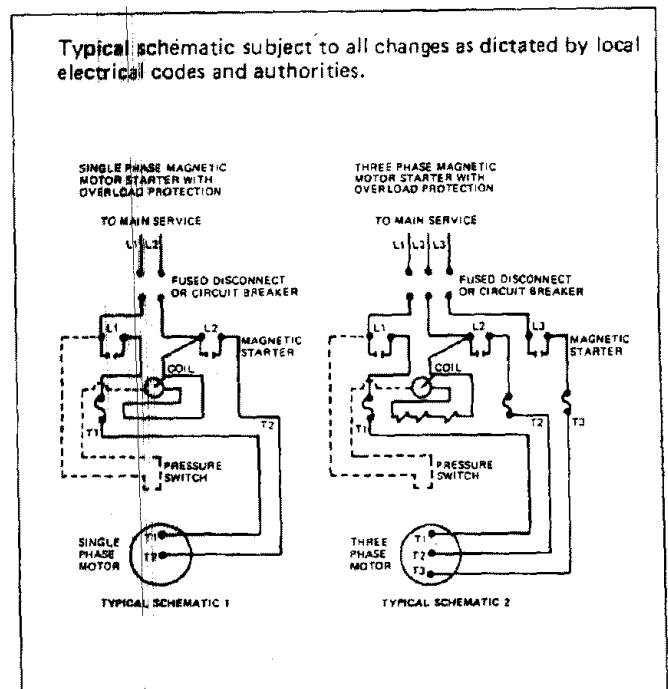
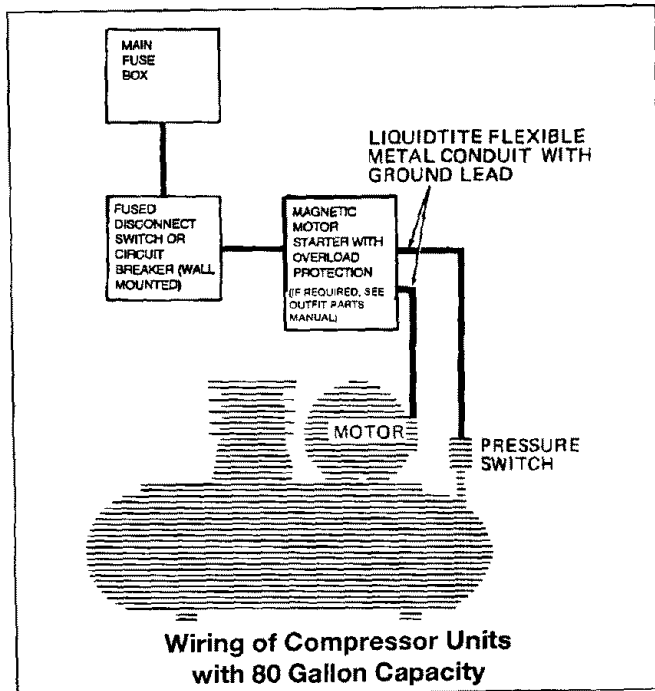

INSTALLATION AND BREAK-IN PROCEDURES

Piping

CAUTION

Plastic or PVC pipe is not designed for use with compressed air. Regardless of its indicated pressure rating, plastic pipe can burst from air pressure. Use only metal pipe for air distribution lines.

Note

Where a remote air intake is used, enlarge the size of the air intake piping by one pipe size for each 10 feet of length.

A typical compressed air distribution system as shown on the following page should be of sufficient pipe size to keep the pressure drop between the supply and point of use to a minimum. All pipes and fittings used must be certified safe for the pressures involved. Pipe thread lubricant must be used on all threads, and all joints are to be made up tight, since small leaks in the piping system are the largest single cause of high operating costs.

All piping should be sloped to an accessible drain point and all outlets should be taken from the top of

the main distribution air line so that moisture cannot enter the outlet.

The main distribution air line should not be smaller than the compressor air discharge valve outlet. A smaller line will restrict the flow of air. If piping is over 100 feet long, or if required air flow will exceed 15 SCFM, use 3/4" piping.

It is recommended that a flexible coupling be installed between the air discharge valve outlet and main air distribution line to allow for vibration.

To remove dirt, oil and water, install a separator in the main distribution line. Install separator 5 to 6 feet from compressor to allow the air to cool to room temperature before passing through the separator. Additional separators or filters may be used depending on the application.

Note

For underground installation, bury air lines below the frost line and avoid pockets where condensation can gather and freeze. Apply pressure before underground lines are covered to make sure all pipe joints are free from leaks.

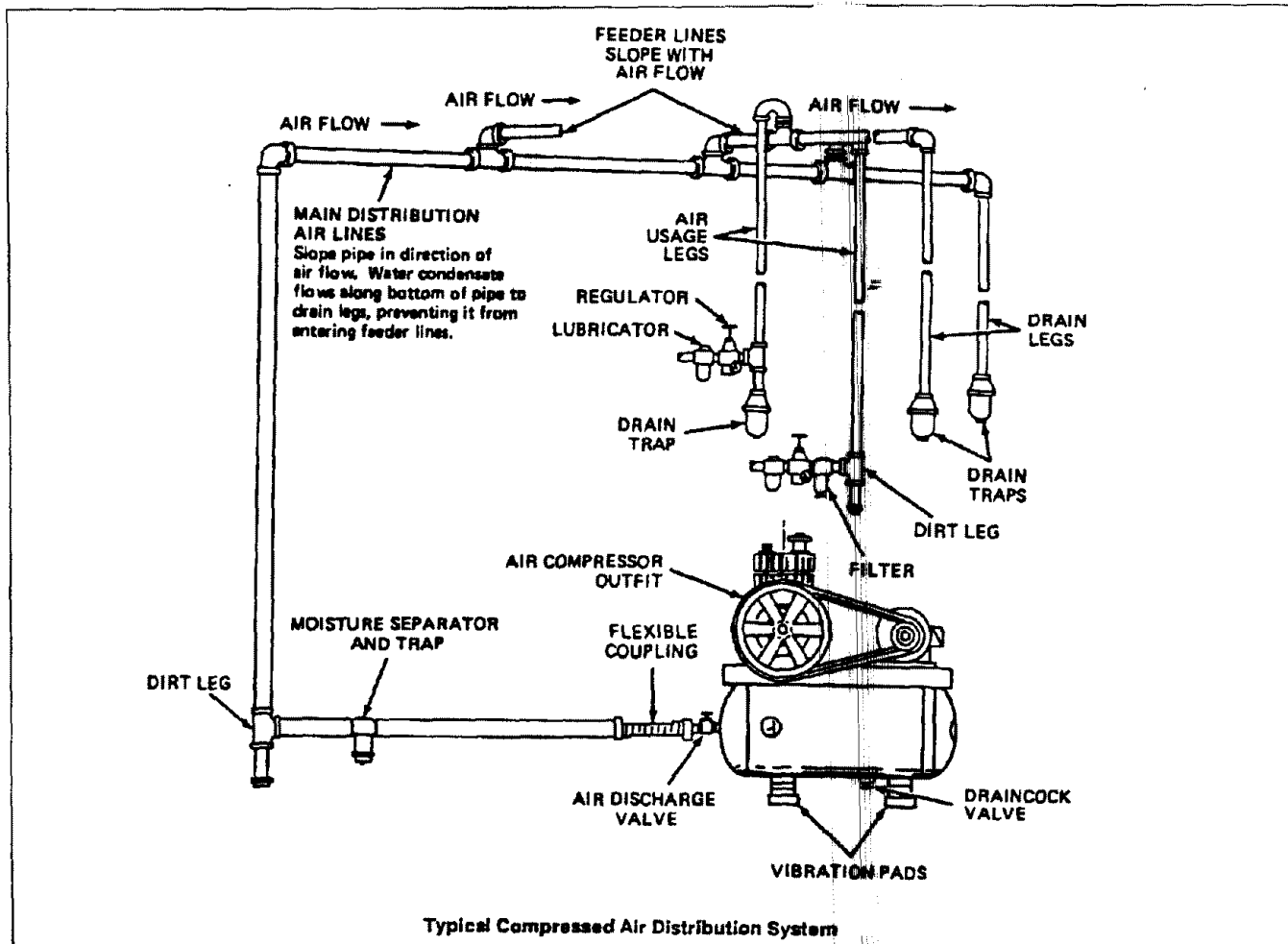

INSTALLATION AND BREAK-IN PROCEDURES

Additional Regulators and Controls

Since the air tank pressure is usually greater than that which is needed, a separate regulator is usually employed to control the air pressure ahead of any individual air driven device.

Separate air transformers that combine the functions of air regulation and moisture and dirt removal should be used where applicable.

Lubrication and Oil

⚠ CAUTION

Compressors are shipped without oil. Do not attempt to operate in order to check wiring or for any reason without first adding oil to the crankcase. Serious damage to the pump can result from even very limited use without oil. Fill crankcase with recommended oil before operating.

Remove the oil fill plug and fill the crankcase with recommended oil. See page 15 in this manual for the specific oil recommended for use in your compressor unit. When filling the crankcase the oil flows in very slowly. If oil is added too quickly, it will overflow and appear full. Replace the oil fill plug.

Break-In Procedures

⚠ CAUTION

Serious damage may result if the following break-in instructions are not closely followed.

This procedure is required only once, before the air compressor is put into service.

1. Recheck compressor wiring. Make sure wires are secure at all terminal connections. Free all contacts of loose wire cuttings, etc.
2. Position the fuse disconnect or circuit breaker to the ON position and, if equipped, turn the ON/AUTO-OFF switch on the pressure switch to the ON position.
3. Open the air outlet valve fully to permit air to escape and prevent air pressure build-up in the tank during the break-in period.
4. Run the compressor for 30 minutes. Make sure the air outlet, or globe valve, is open and there is no tank pressure build-up.
5. Check all air line fittings and connections/piping for air leaks by applying a soap solution. Correct as necessary. Even minor leaks can cause this air compressor to overwork, resulting in premature breakdown or inadequate performance.
6. Check for excessive vibration and noise. Adjust air compressor belt guard as necessary to eliminate chatter. Re-adjust or shim the air compressor feet, if necessary, for proper level.
7. Close the outlet valve and let air compressor pump up to "cut-out pressure". Turn the air compressor off and check oil level. Add oil if necessary. Connect air hose to air outlet adapter.

Your compressor is now ready for use.

OPERATING PROCEDURES

1. Before attaching an air hose or accessory, make sure the outlet valve is in the closed position. On units equipped with a pressure switch lever make sure the switch is in the OFF position.

⚠ CAUTION

Compressed air from the outfit may contain water condensation and oil mist. Do not spray unfiltered air at an item that could be damaged. Some air operated tools or devices may require filtered air. Read instructions for air tool or device.

2. Attach regulator, hose and accessory. On models without an air pressure regulator, one must be installed before using accessories rated at less than 125 psig.

⚠ DANGER

Too much air pressure causes a hazardous risk of bursting. Check the manufacturer's maximum pressure rating for air tools and accessories. The regulator outlet pressure must never exceed the maximum pressure rating.

3. Turn the compressor on and allow tank pressure to build. On units equipped with a pressure switch lever, place the switch in the ON-AUTO position. The motor will stop when tank pressure reaches "cut-out pressure".
4. Open the outlet valve.

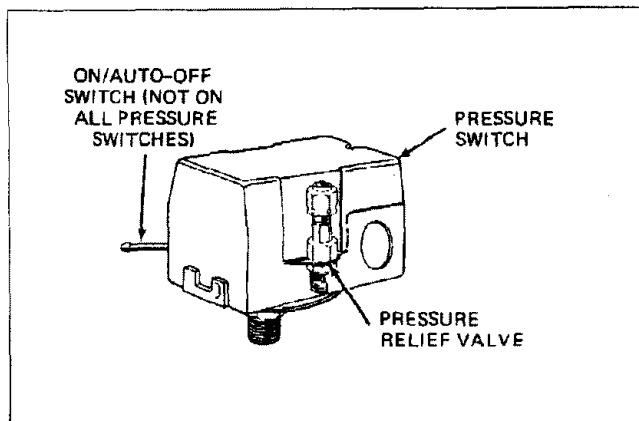

5. If an air pressure regulator is in use, open the regulator by turning it clockwise. Adjust the regulator to the correct pressure setting. Your outfit is ready for use.

When You Are Finished:

6. Turn the compressor unit off.
7. Turn the regulator counterclockwise and set the outlet pressure to zero.
8. Remove the air tool or accessory.
9. Open the regulator and allow the air to slowly bleed from the tank. Close the regulator when tank pressure is approximately 20 psi.
10. Drain water from air tank.

⚠ WARNING

WATER WILL CONDENSE IN THE AIR TANK. IF NOT DRAINED, THE WATER WILL CORRODE AND WEAKEN THE AIR TANK, CAUSING A RISK OF AIR TANK RUPTURE. THE AIR TANK MUST BE DRAINED PROPERLY.

11. After the water has been drained, close the drain cock.
 - if the compressor is under continuous use - drain at least once each day.
 - if the compressor is only used occasionally - drain after each use.

Operate the unit to apply 15-20 psig and open the drain cock. Collect the water in a suitable container. Continue operating unit until all moisture is removed from the air tank. Close the drain cock tightly.

Note

If drain cock valve is clogged, release air pressure in air tank. The drain cock valve can then be removed, cleaned and reinstalled.

MAINTENANCE

⚠ DANGER

UNIT CYCLES AUTOMATICALLY WHEN POWER IS ON. DURING MAINTENANCE, YOU COULD BE EXPOSED TO VOLTAGE SOURCES, COMPRESSED AIR OR MOVING PARTS. PERSONAL INJURIES CAN OCCUR. UNPLUG THE UNIT AND BLEED OFF ALL AIR TANK PRESSURE BEFORE DOING ANY MAINTENANCE OR REPAIR. NEVER OPERATE THE UNIT WITH THE BELT GUARD REMOVED.

To ensure efficient operation and longer life of the air compressor outfit, a routine maintenance schedule should be prepared and followed. The following routine maintenance schedule is geared to an outfit in a normal working environment operating on a daily basis. If necessary, the schedule should be modified to suit the conditions under which your compressor is used. The modifications will depend upon the hours of operation and the working environment. Compressor outfits in an extremely dirty and/or hostile environment will require a greater frequency of all maintenance checks. Lubricate compressor motor according to manufacturer's instructions, which are attached to your motor.

A clean air compressor runs cooler and provides longer service. Clean or blow off fins and any other parts of the air compressor that collect dust or dirt. Do not place rags, containers or other material on or against the ventilation openings in the belt guard. Adequate ventilation is necessary to maintain proper air compressor operating temperature.

Routine Maintenance Schedule

Every 8 Hours of Operation

⚠ CAUTION

Overfilling with oil will cause premature compressor failure. Do not overfill.

1. Check oil level. Add if necessary.
2. Drain water from the air tank, any moisture separators or transformers.
3. Check for any unusual noise and/or vibration.
4. Manually check all safety valves to make sure they are operating properly.
5. Inspect for oil leaks and repair any leaks found.

Every 40 Hours of Operation (Single & 2 Stage Compressors)

1. Clean and inspect the air intake filter; replace if necessary.
2. Inspect condition of drive belt; replace if necessary.

First 100 Hours of Operation (Single & 2 Stage Compressors)

1. Drain and refill compressor crankcase with clean oil. Refer to Service Instructions for recommended oils.
2. Increase frequency of oil changes if humidity or operating conditions are extreme.

Every 100 Hours of Operation (Single Stage)

1. Drain and refill compressor crankcase with 16 fluid ounces (473.2ml) of clean oil, SAE-20W-20 SG. (Use SAE 10W oil under winter-type conditions.)
2. Increase frequency of oil changes if humidity or operating conditions are extreme.

Every 160 Hours of Operation (Single & 2 Stage Compressors)

1. Check drive belt tension; adjust if necessary. (See page 15.)
2. Inspect air lines and fittings for leaks; correct as necessary.
3. Check the alignment of the motor pulley to the flywheel. If necessary, align to within 1/32 inch on center line.

Every 500 Hours of Operation (2 stage compressor units)

1. Drain and refill compressor crankcase with clean oil. See page 14 for recommended oils.
2. Increase frequency of oil changes if humidity or operating conditions are extreme.

Each Year of Operation (2000 Hours) or if a Problem is Suspected (Single & 2 Stage Compressors)

Check condition of air compressor pump intake and exhaust valves. Replace if damaged or worn out. (Refer to the Outfit Parts Bulletin.)

SERVICE INSTRUCTIONS

Air Filter - Inspection and Replacement

NOTE

Keep the air filter clean at all times. Do not operate the compressor with the air filter removed.

A dirty air filter will not allow the compressor to operate at full capacity. Before you use the compressor, check the air filter to be sure it is clean.

If it is dirty, replace it with a new filter. On some models, the filter may be removed by using a pair of needle nosed pliers or a screwdriver. Pull or pry out the old filter. Push in the new air filter. Other models require removal of the belt guard and/or filter retainer.

Oil - Checking and Changing

CAUTION

Overfilling with oil will cause premature compressor failure. Do not overfill.

1. Check oil level in compressor crankcase before each use. The oil level should be to the middle of the oil sight glass. On compressors without a sight glass the oil level must not be allowed to be lower than 3/8" from the top (6 threads) at any time.
2. Replace the oil after:
Two Stage - 500 hours of operation. (Replace oil after initial 100 hours of operation.)
3. Remove the oil fill and drain plugs. Collect the oil in a suitable container.
4. Replace the oil drain plug and refill the crankcase with recommended oil. When filling the crankcase the oil flows in very slowly. If oil is added too quickly, it will overflow and appear full.

NOTE

It is important to maintain the proper oil level. A low oil level reduces proper cylinder wall lubrication and increases ring wear.

5. Replace the oil fill plug.
6. Start the compressor outfit and run for several minutes. Shut the compressor down and check the oil level. If necessary, add more oil.

Two Stage Compressor Units

Viscosity Chart

Recommended Oil (API SG/CD Heavy Duty)	Room or Ambient Temperature
SAE 20 SAE 40	Below 20°F Above 32°F

Crankcase capacity equals (approximately) 42 fluid ounces.

Check Valve - Inspection and Replacement

Remove and inspect the check valve at least once a year or more often if the compressor is heavily used. Moisture and other contaminants in the hot compressed air will cause an accumulation of a carbon-like residue on the working parts. If the valve has heavy carbon build-up, it should be replaced. Use the following procedure to inspect, clean or replace the check valve.

1. Turn compressor off and disconnect or lock out power source.
2. Release air pressure from the air tank.
3. Loosen the top and bottom tube nuts and remove the outlet tube.
4. Unscrew the check valve (turn counterclockwise) using socket wrench.

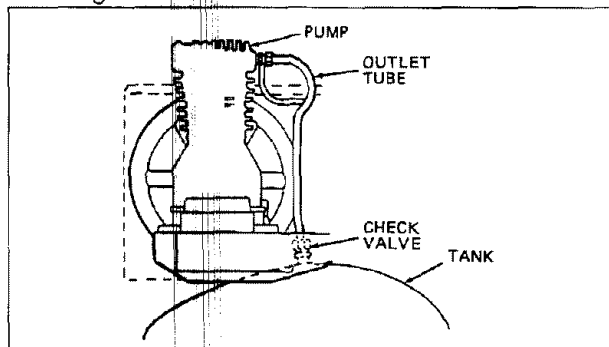

5. Check that the valve disc moves freely and that the spring holds the disc in the upper, closed position. The check valve may be cleaned with a solvent.
6. Apply sealant to the check valve threads. Reinstall the check valve (turn clockwise). Do not over-tighten.
7. Replace the outlet tube and tighten top and bottom nuts.

SERVICE INSTRUCTIONS

Safety Valve - Inspection and Replacement

⚠ WARNING

IF THE SAFETY VALVE DOES NOT WORK PROPERLY, OVER-PRESSURIZATION MAY OCCUR, CAUSING AIR TANK RUPTURE OR EXPLOSION. OCCASIONALLY PULL THE RING ON THE SAFETY VALVE TO MAKE SURE THAT THE SAFETY VALVE OPERATES FREELY. IF THE VALVE IS STUCK OR DOES NOT OPERATE SMOOTHLY, IT MUST BE REPLACED WITH A VALVE HAVING THE SAME PRESSURE RATING.

The safety valve is set at the factory to a pressure approximately 15 pounds higher than the rated pressure of the outfit. If the pressure switch malfunctions and does not shut off the motor automatically at maximum tank pressure, the safety valve will protect the air tank against excessive air pressure by popping off at its preset pressure.

Two stage compressor pumps equipped with after-coolers will have a second safety valve installed on the aftercooler.

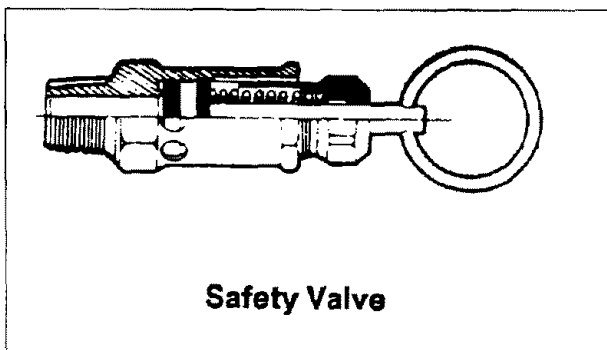

Belt - Replacement

(Refer to the Outfit Parts Bulletin for replacement belt part number.)

⚠ DANGER

SERIOUS INJURY OR DAMAGE MAY OCCUR IF PARTS OF THE BODY OR LOOSE ITEMS GET CAUGHT IN MOVING PARTS. NEVER OPERATE THE OUTFIT WITH THE BELT GUARD REMOVED. THE BELT GUARD SHOULD BE REMOVED ONLY WHEN THE COMPRESSOR POWER IS DISCONNECTED.

1. Turn compressor off, lock out the power supply, and relieve all air pressure from the tank.
2. Remove the belt guard. If the guard is plastic, remove the front of the belt guard by disengaging the snaps. Insert a flat bladed screwdriver at each snap location and pry the belt guard apart.
If the belt guard is wire mesh, remove four screws, four clips and outer panel of belt guard.
3. For compressors with a motor tilt plate, loosen the wing nut at the tilt plate. The motor can be tilted to allow for easy removal or installation of the belt.
For compressors with a motor slide mount, loosen the motor mounting hardware and slide the motor toward the compressor.
4. Remove the belt and replace with a new one.

Adjusting Belt Tension

Adjust belt tension as described below.

For compressors with motor tilt plate, tighten the wing nut until it makes contact with the washer, plus one additional turn.

For compressors with a motor slide mount, adjust belt tension as follows:

1. Slide motor away from compressor until desired tension is obtained.

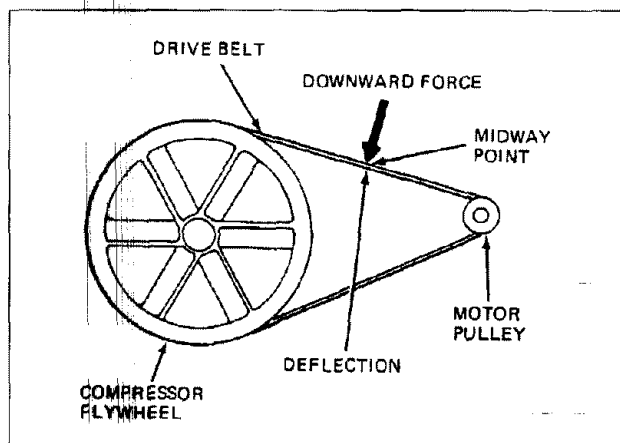

On two stage compressors, the belt should deflect 3/16" at midway between the pulley and the flywheel when a 5 pound weight is applied at the midway point.

2. Tighten two outside cap screws enough to hold the motor in place for checking pulley and flywheel alignment.

SERVICE INSTRUCTIONS

Motor Pulley and Flywheel Alignment

(slide mount compressors only)

1. Place a straight edge along the outside face of the compressor flywheel to check alignment of V-belt grooves. (See figure below for proper alignment.)
2. If the belt grooves aren't aligned, continue with step 3 of this procedure. If the belt grooves are aligned, continue with step 4 of this procedure.
3. Loosen motor mounting screws and move the motor until motor pulley is in proper alignment.
4. Tighten all four motor mounting screws to 10-20 ft-lbs.
5. Reinstall belt guard.

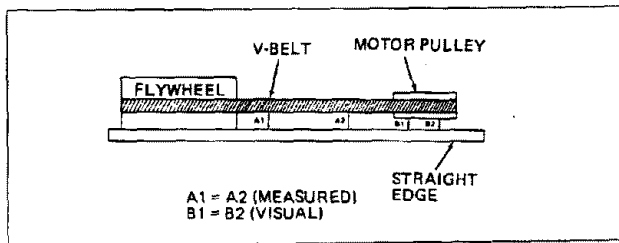

Motor Overload Protector - Reset

The electric motor has a thermal overload protector. If the motor overheats for any reason, the thermal overload protector will shut off the motor. The motor must be allowed to cool down before restarting.

If equipped with an ON/AUTO-OFF pressure switch, restart as follows:

1. Turn the ON/AUTO-OFF switch to the OFF position.
2. Depress the reset button located on the end of the electrical motor.
3. To restart the motor, turn the ON/AUTO-OFF switch to the ON/AUTO position.

If not equipped with an ON/AUTO-OFF pressure switch, restart as follows:

1. Position the fuse disconnect or circuit breaker to the OFF position.
2. Depress the reset button located on the end of the electrical motor.

3. To restart the motor, turn the ON/AUTO-OFF switch to the ON/AUTO position.

NOTE

If the thermal overload protector shuts the motor off frequently, check for possible voltage problems. Low voltage can also be suspected when:

1. The motor does not get up to full power or speed.
2. Fuses blow out when starting the motor.
3. Lights dim and remain dim when motor is started.

Motor Lubrication

Follow the manufacturer's recommendations that are attached to your motor.

Compressor Head Bolts - Torquing (two stage compressors only)

The compressor head bolts should be kept properly torqued. Check the torques of the head bolts after the first five hours of operation, and compare the values to the value shown in the table below. Retighten if necessary. Torque values are also shown for other compressor fasteners should disassembly be necessary.

Torque Valve Table for Bare Compressor Metric Fasteners

Head Bolts	20 ft-lb
Frame to Cylinder Bolts	25 ft-lb
Bearing End Covers	5 ft-lb
Aftercooler Bolts	20 ft-lb
Filter Support Bolts	20 ft-lb
Crankcase Base Screws	20 in-lb
Oil Drain Plug	5 ft-lb
Oil Sight Glass	10 in-lb
Rod Bearing Screws	25 ft-lb
Intercooler Screws	20 ft-lb
Flywheel Bolt	20 ft-lb

Additional Service

Disassembly or service of the air compressor beyond what is covered in this manual is not recommended. If additional service is required, contact your nearest Authorized Warranty Service Center.

TROUBLESHOOTING GUIDE

⚠ DANGER

PERFORMING REPAIRS MAY EXPOSE VOLTAGE SOURCES, MOVING PARTS OR COMPRESSED AIR SOURCES. PERSONAL INJURY MAY OCCUR. PRIOR TO ATTEMPTING ANY REPAIRS, UNPLUG THE COMPRESSOR AND BLEED OFF ALL TANK AIR PRESSURE.

PROBLEM	CAUSE	CORRECTION
Excessive tank pressure - safety valve pops off (units with ON-AUTO switch)	Pressure switch does not shut off motor when compressor reaches "cut-out" pressure. Pressure switch "cut-out" too high.	Move the pressure switch lever to the "OFF" position. If the outfit doesn't shut off, and the electrical contacts are welded together, replace the pressure switch. If the contacts are good, check to see if the pin in the bottom of the pressure release valve is stuck. If it does not move freely, replace the valve. Return the outfit to Service Center to check and adjust, or replace switch.
Excessive tank pressure - safety valve pops off (units without ON-AUTO switch).	Pressure switch does not shut off motor when compressor reaches "cut-out pressure".	Pressure switch must be replaced.
Air leaks at fittings or hose.	Tube fittings are not tight enough.	Tighten fittings where air can be heard escaping. Check fittings with soapy water solution. DO NOT OVERTIGHTEN.
Air leaks at or inside check valve.	Defective or dirty check valve.	A defective check valve results in a constant air leak at the pressure release valve when there is pressure in the tank and the compressor is shut off. Remove and clean or replace check valve. DO NOT OVERTIGHTEN.
Air leaks at pressure switch release valve during running.	Defective pressure switch release valve.	Remove and replace the release valve.
Continuous air relieving from pressure switch release valve after shut off.	Defective check valve.	See "Air Leak at Check Valve."
Air leaks in air tank or at air tank welds.	Defective air tank.	Air tank must be replaced. <div style="text-align: center; background-color: black; color: white; padding: 5px; border: 1px solid black;">⚠ WARNING</div> DO NOT DRILL INTO, WELD, OR OTHERWISE MODIFY AIR TANK. IT WILL WEAKEN. THE TANK CAN RUPTURE OR EXPLODE.
Air leak from safety valves.	Possible defect in safety valves.	Operate safety valves manually by pulling on ring. If a valve still leaks, it should be replaced.
Squealing sound.	Loose belt. There is no oil in the compressor.	Adjust belt tension. (See Belt Replacement.) Add oil.

TROUBLESHOOTING GUIDE

PROBLEM	CAUSE	CORRECTION
Motor will not run.	<p>Motor overload protection switch has tripped.</p> <p>Possible defective capacitor.</p> <p>Tank pressure exceeds pressure switch "cut-in pressure".</p> <p>Check valve stuck open.</p> <p>Loose electrical connections.</p> <p>Paint spray on internal motor parts.</p> <p>Possible defective motor.</p> <p>Fuse blown, circuit breaker tripped.</p> <p>Pressure release valve on pressure switch has not unloaded head pressure.</p>	<p>Let motor cool off and reset switch by pressing the red button located on the end of the motor. If the overload still trips, check for defective capacitor.</p> <p>Return to Service Center for inspection or replacement if necessary.</p> <p>Motor will start automatically when tank pressure drops below "cut-in pressure" of pressure switch.</p> <p>Remove and clean or replace. DO NOT OVERTIGHTEN.</p> <p>Check wiring connection inside pressure switch and motor terminal box area.</p> <p>Have checked at Service Center. Do not operate the compressor in the spray area. See Flammable Vapor Warning.</p> <p>Have checked at a local Service Center.</p> <ol style="list-style-type: none"> 1. Check fuse box for blown fuse and replace if necessary. Reset circuit breaker. Do not use a fuse or circuit breaker with higher rating than that specified for your particular branch circuit. 2. Check for proper fuse; only dual element time delay fuses are acceptable. Use a Type "T" time delay fuse. 3. Check for low voltage conditions and/or proper extension cord. 4. Remove check valve and clean or replace if it is stuck open or closed. 5. Disconnect the other electrical appliances from circuit or operate the compressor on its own branch circuit. <p>On an on/auto pressure switch equipped with a pressure relief valve, bleed the line by pushing the pressure switch to the OFF position. If valve does not open, bend the lever until it does. If valve still fails to bleed, replace the valve assembly.</p>
Excessive belt wear.	<p>Loose belt/tight belt.</p> <p>Loose pulley.</p>	<p>Adjust belt tension. (See Belt Replacement.)</p> <p>Check for worn keyway or pulley bore. Also check for bent motor shaft. Replace parts if necessary. (Refer to the Outfit Parts Bulletin.)</p>
Compressor is not supplying enough air to operate accessories.	<p>Prolonged excessive use of air.</p> <p>Compressor is not large enough for air requirement.</p> <p>Restricted air intake filter.</p>	<p>Decrease amount of air usage.</p> <p>Check the accessory air requirement. If it is higher than the CFM or pressure supplied by your air compressor, you need a larger compressor.</p> <p>Clean or replace air intake filter. Do not operate the compressor in the paint spray area.</p>

TROUBLESHOOTING GUIDE

PROBLEM	CAUSE	CORRECTION
Compressor is not supplying enough air to operate accessories. (Continued)	<p>Loose belt.</p> <p>Hole in hose.</p> <p>Check valve restricted.</p> <p>Air leaks.</p>	<p>Adjust belt tension.</p> <p>Check and replace if required.</p> <p>Remove and clean or replace.</p> <p>Tighten fittings. (See "Air Leaks" section of "Troubleshooting Guide".)</p>
Knocking noise.	<p>Defective check valve.</p> <p>Loose pulley.</p> <p>Low oil level.</p> <p>Loose flywheel.</p> <p>Loose compressor mounting screws.</p> <p>Belt too tight/too loose.</p> <p>Carbon build-up.</p>	<p>Remove and clean or replace.</p> <p>Tighten pulley set screw, 70-80 in-lb.</p> <p>Maintain prescribed oil level. Add oil.</p> <p>Tighten screw, 15 to 20 ft-lb.</p> <p>Check screws. Tighten as required.</p> <p>Adjust belt tension. (See Belt Replacement.)</p> <p>Remove the head and valve plate. Clean the valve plate and the top of the piston. (Be sure carbon does not fall into the cylinder.) Reassemble using new gaskets and torque screws, 25 to 30 ft-lb.</p>
Excessive oil consumption.	<p>Restricted air intake.</p> <p>Compressor overworked.</p> <p>Poor quality oil.</p>	<p>Replace the air intake.</p> <p>Reduce air consumption or add another air compressor to take up some of the load.</p> <p>Drain pump and replace with correct oil. Refer to Lubrication and Oil Section.</p>
Compressor overheating.	<p>The compressor is overworked.</p> <p>The aftercooler tube and/or check valve is restricted.</p> <p>Dirty compressor.</p> <p>High ambient temperature.</p>	<p>Reduce air consumption or add another air compressor to take up some of the load.</p> <p>Check the tube and the check valve. Clean if necessary.</p> <p>Clean the compressor thoroughly.</p> <p>Use remote air intake.</p>
Motor overheating.	<p>Incorrect oil, low oil.</p> <p>Compressor starting against load.</p> <p>Low voltage.</p> <p>Pressure switch set beyond factory setting.</p> <p>Belt too tight.</p> <p>Compressor valves have excessive carbon deposits build-up; restricted check valve.</p>	<p>See oil recommendation on page 14.</p> <p>Improper pressure switch. Replace with correct switch.</p> <p>Provide correct voltage. Consult local power company or electrician.</p> <p>Do not set switch beyond maximum for which outfit was designed as noted on nameplate.</p> <p>Adjust for proper tension.</p> <p>Clean or replace compressor valves or check valve.</p>

TROUBLESHOOTING GUIDE

PROBLEM	CAUSE	CORRECTION
Motor overheating. (Continued)	<p>Too many motor starts per hour.</p> <p>Improper wiring gauge. Incorrect voltage.</p>	<p>Consult Service Center.</p> <p>Check electrical hookup and installation data or consult electrician.</p>
<p>NOTE</p> <p>Current style electric motors run relatively hot under normal operating conditions, with reasonable compressor loading. This condition is normal and no adjustment is necessary.</p> <p>Under normal operating conditions, the motor amperage draw will not exceed the nameplate amperage rating, plus the service factor, as it appears on the electric motor. If a condition of sustained high amperage exists, refer to service checks above and/or consult electrician. If cause cannot be isolated by an electrician, consult with Service Center for additional assistance.</p>		
Water in pump crankcase; oil appears milky in color.	<p>Humid operating conditions.</p> <p>Unit not reaching proper operating temperature because the compressor runs infrequently and is oversized for the air requirement.</p>	<p>Relocate compressor outfit, or change oil frequently.</p> <p>Consult Service Center.</p>

SERVICE NOTES

SERVICE NOTES

SERVICE NOTES

SEARS

GENERAL MANUAL

When requesting service or ordering parts, always provide the following information:

- Model Number
- Part Number
- Part Description
- Name of Item

FULL ONE YEAR WARRANTY AIR COMPRESSOR

If this air compressor fails due to a defect in material or workmanship within one year from the date of purchase, RETURN IT TO THE NEAREST SEARS REPAIR CENTER THROUGHOUT THE UNITED STATES AND SEARS WILL REPAIR IT, FREE OF CHARGE.

If this air compressor is used for commercial or rental purposes, the warranty will apply for ninety days from the date of purchase.

This warranty gives you specific legal rights and you may have other rights which vary from state to state.

CRAFTSMAN®

OIL LUBRICATED STATIONARY AIR COMPRESSORS

For the repair or replacement parts you need

Call 7 am - 7 pm, 7 days a week

1-800-366-PART

(1-800-366-7278)

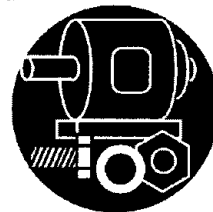

For in-home major brand repair service

Call 24 hours a day, 7 days a week

1-800-4-REPAIR

(1-800-473-7247)



For the location of a
Sears Parts and Repair Center in your area

Call 24 hours a day, 7 days a week

1-800-488-1222



For information on purchasing a Sears

Maintenance Agreement or to inquire

about an existing Agreement

call 9 am - 5 pm, Monday-Saturday

1-800-827-6655



SEARS
REPAIR SERVICES
America's Repair Specialists

Sears, Roebuck and Co., Hoffman Estates, IL 60179 U.S.A.