

Brother Laser Printer USER'S GUIDE

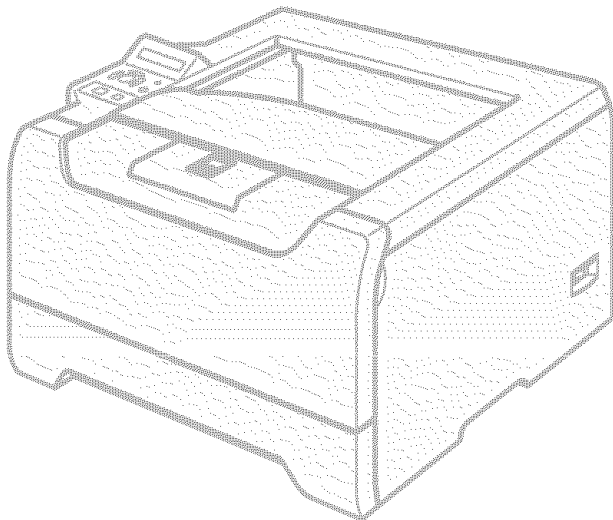

HL-5270DN
HL-5280DW

For visually-impaired users

You can read this manual with Screen Reader 'text-to-speech' software.

You must set up the hardware and install the driver before you can use the printer.

Please use the Quick Setup Guide to set up the printer. You can find a printed copy in the box.

Please read this User's Guide thoroughly before you use the printer. Keep the CD-ROM in a convenient place so you can use it quickly if you need to. You can also read the User's Guide in HTML format by visiting our web site at <http://solutions.brother.com> or accessing it from the CD-ROM directly.

Please visit us at <http://solutions.brother.com> where you can get product support, the latest driver updates and utilities, and answers to frequently asked questions (FAQs) and technical questions.

Note: The HL-5270DN is not available in the USA and Canada.



Using this guide

Symbols used in this guide

We use the following icons throughout this User's Guide:



Warnings tell you what to do to prevent possible personal injury.



Electrical Hazard icons alert you to a possible electrical shock.



Hot Surface icons warn you not to touch machine parts that are hot.



Cautions specify procedures you must follow or avoid to prevent possible damage to the printer or other objects.



Improper Setup icons alert you to devices and operations that are not compatible with the printer.



Notes tell you how you should respond to a situation that may arise or give tips about how the operation works with other features.

Safety precautions

To use the printer safely

WARNING



There are high voltage electrodes inside the printer. Before you clean the inside of the printer, make sure that you have turned off the power switch and unplugged the printer from the AC power outlet.

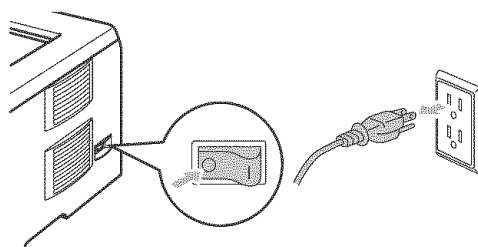

DO NOT handle the plug with wet hands. Doing this might cause an electrical shock.

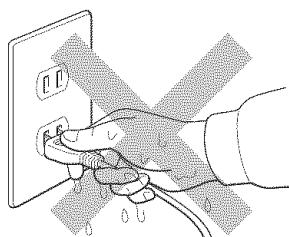

After you have just used the printer, some internal parts of the printer will be extremely hot. When you open the front or back cover of the printer, DO NOT touch the shaded parts shown in the illustration.

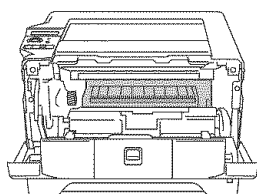

Inside the printer
(Front View)

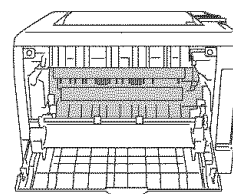

Open the back cover
(Back View)



DO NOT remove or damage the caution labels located on or around the fuser.

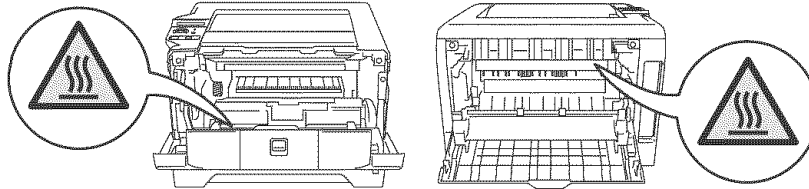

DO NOT use a vacuum cleaner to clean up scattered toner. Doing this might cause the toner dust to ignite inside the vacuum cleaner, potentially starting a fire. Carefully clean the toner dust with a dry, lint-free cloth and dispose of it according to local regulations.

DO NOT use flammable substances near the printer. Doing this might cause a fire or electrical shock.

 **CAUTION**

Cleaning the outside of the printer:

- Make sure that you have unplugged the printer from the AC power outlet.
 - Use neutral detergents. Cleaning with volatile liquids such as thinner or benzine will damage the outside surface of the printer.
 - DO NOT use cleaning materials that contain ammonia.
-

Trademarks

The Brother logo is a registered trademark of Brother Industries, Ltd.

Apple, the Apple Logo, Macintosh and TrueType are registered trademarks of Apple Computer, Inc in the United States and other countries.

Epson is a registered trademark and FX-80 and FX-850 are trademarks of Seiko Epson Corporation.

Hewlett Packard is a registered trademark and HP LaserJet 6P, 6L, 5P, 5L, 4, 4L 4P, III, IIIP, II, and IIP are trademarks of Hewlett-Packard Company.

IBM, IBM PC, and Proprinter are registered trademarks of International Business Machines Corporation.

Microsoft, MS-DOS, Windows and Windows NT are registered trademarks of Microsoft Corporation in the U.S. and other countries.

PostScript and PostScript 3 are trademarks of Adobe Systems Incorporated.

Citrix and MetaFrame are registered trademarks of Citrix Systems, Inc. in the United States.

SuSE is a registered trade mark of SuSE Linux AG.

RED HAT is a registered trade mark of Red Hat. Inc.

Mandrake is a registered trade mark of Mandrake Soft SA.

Intel, Intel Xeon and Pentium are trademarks or registered trademarks of Intel Corporation.

AMD, AMD Athlon, AMD Opteron and combinations thereof, are trademarks of Advanced Micro Devices, Inc.

Java and all Java-based trademarks and logos are trademarks or registered trademarks of Sun Microsystems, Inc. in the United States and other countries.

All other terms and brand and product names mentioned in this User's Guide are registered trademarks of their respective companies.

Compilation and Publication Notice

Under the supervision of Brother Industries Ltd., this manual has been compiled and published, covering the latest product's descriptions and specifications.

The contents of this manual and the specifications of this product are subject to change without notice.

Brother reserves the right to make changes without notice in the specifications and materials contained herein and shall not be responsible for any damages (including consequential) caused by reliance on the materials presented, including but not limited to typographical and other errors relating to the publication.

© 2005 Brother Industries Ltd.

Shipment of the Printer

If for any reason you must ship your printer, carefully package the printer to avoid any damage during transit. We recommend that you save and use the original packaging. The printer should also be adequately insured with the carrier.

Table of Contents

1 About this Printer

What is in the box?	1
Interface cable	1
Front view	2
Back view	3
Positioning the printer	4
Power supply	4
Environment	4
Network features.....	5

2 Printing Methods

About paper	6
Type and size of paper	6
Recommended paper	7
Printable area	9
Printing methods.....	10
Printing on plain paper, bond paper and transparencies	10
Printing on thick paper, labels and envelopes	16
Duplex Printing	20
Guidelines for printing on both sides of the paper	20
Manual duplex printing	20
Automatic duplex printing	22
Booklet printing (For Windows printer driver)	24
Carbon copy printing.....	25

3 Driver and Software

Printer driver	26
Features in the printer driver (For Windows®)	28
Features in the BR-Script (PostScript® 3™ language emulation) printer driver (For Windows®).....	36
Features in the printer driver (For Macintosh®)	39
Uninstalling the printer driver	42
Software	44
Software for networks	44
About emulation modes	45
Automatic emulation selection	45
Automatic interface selection.....	46

4 Control Panel

Control panel	47
Buttons	48
Go	48
Job Cancel.....	48
Reprint	49
+ or - button	49
Back.....	49
Set	49

Data LED	50
LCD	50
Back light	50
LCD messages	51
Reprinting documents	52
Using the control panel LCD menu	55
Menu table	56
Default Settings	68
Printer default setting	68
Network default setting	68

5 Options

Lower tray unit (LT-5300)	69
DIMM	70
DIMM types	70
Installing extra memory	71

6 Routine Maintenance

Replacing the consumable items	73
Consumables	74
Toner cartridge	74
Drum unit	80
Replacing periodic maintenance parts	84
Cleaning	85
Cleaning the outside of the printer	85
Cleaning the inside of the printer	86
Cleaning the corona wire	89

7 Troubleshooting

Identifying your problem	91
LCD messages	92
Error message printout	94
Paper handling	95
Paper jams and how to clear them	96
JAM MP TRAY (Paper jam in the MP tray)	97
JAM TRAY 1 / TRAY 2 / TRAY 3 (Paper jam inside the paper tray)	97
JAM INSIDE (Paper jam inside the printer)	99
JAM REAR (Paper jam behind the back cover)	101
JAM DUPLEX (Paper jam in the duplex tray)	104
Improving the print quality	105
Solving print problems	111
Network problems	112
Other problems	112
For Macintosh® with USB	112
Printing from DOS	112
BR-Script 3	113

A Appendix

Printer specifications.....	114
Engine	114
Controller	115
Software	116
Control panel	116
Paper handling	116
Media specifications	117
Supplies.....	117
Dimensions / Weights.....	117
Other.....	118
System Requirements	118
Important information for choosing your paper.....	119
Symbol and character sets	122
How to use the web browser	122
Symbol and character sets list.....	123
Quick reference for bar code control commands.....	125
Print bar codes or expanded characters.....	125

B Appendix (For Europe and Other Countries)

Brother Numbers	132
Important information: Regulations.....	133
Radio interference (220 to 240 volt model only).....	133
IEC 60825-1 specification (220 to 240 volt model only).....	133
Internal laser radiation	134
EU Directive 2002/96/EC and EN50419.....	134
IMPORTANT - For Your Safety	135
EC Declaration of Conformity	136

C Appendix (For USA and Canada)

Brother Numbers	137
Important information: Regulations.....	139
Federal Communications Commission (FCC) Declaration of Conformity (For USA).....	139
Industry Canada Compliance Statement (For Canada)	140
Laser Notices.....	141
Laser Safety (110 to 120 volt model only).....	141
FDA Regulations (110 to 120 volt model only).....	141
Internal laser radiation	141
IMPORTANT - For Your Safety	142

D Index

1

About this Printer

What is in the box?

When you unpack the printer, make sure that you have all of the following parts.

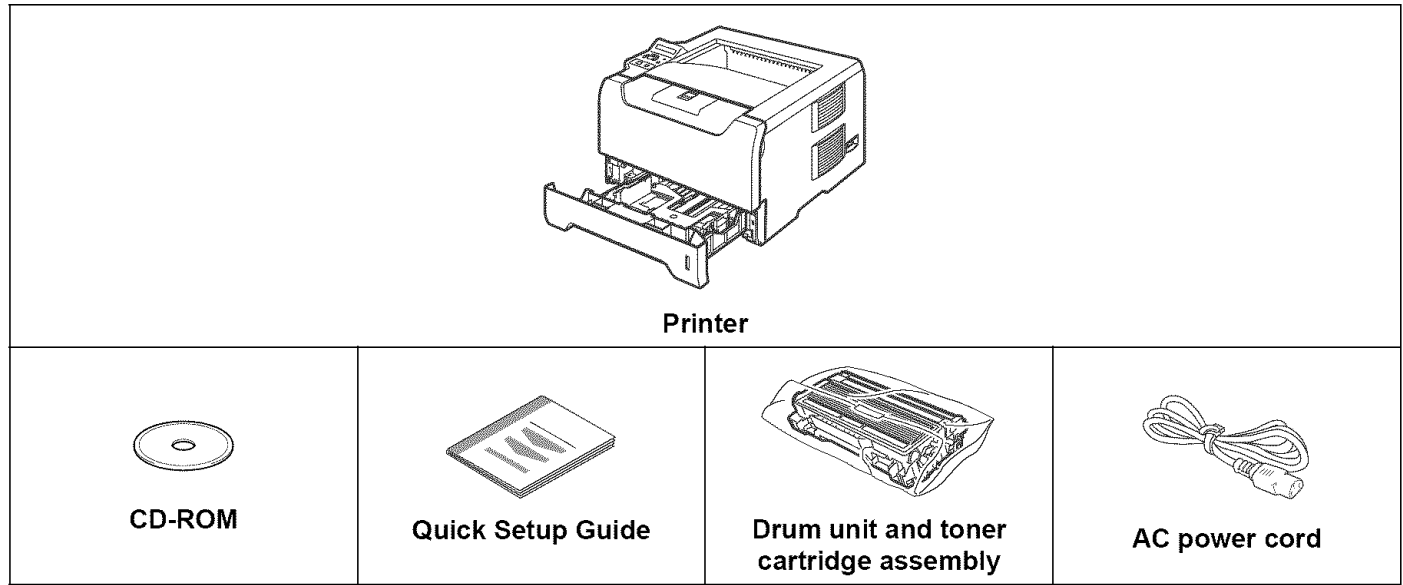

Interface cable

An interface cable is not a standard accessory. Buy the proper interface cable for the interface you want to use (USB, parallel or network).

■ USB cable

Do not use a USB interface cable that is longer than 6 feet (2.0 meters).

Do not connect the USB cable to a non-powered hub or a Macintosh® keyboard.

Make sure that you connect it to the USB connector of your PC.

USB is not supported under Windows® 95 or Windows NT® 4.0.

■ Parallel interface

Do not use a parallel interface cable that is longer than 6 feet (2.0 meters).

Use a shielded interface cable that is IEEE 1284-compliant.

■ Network cable

Use a straight-through Category5 (or greater) twisted-pair cable for 10BASE-T or 100BASE-TX Fast Ethernet Network.

Front view

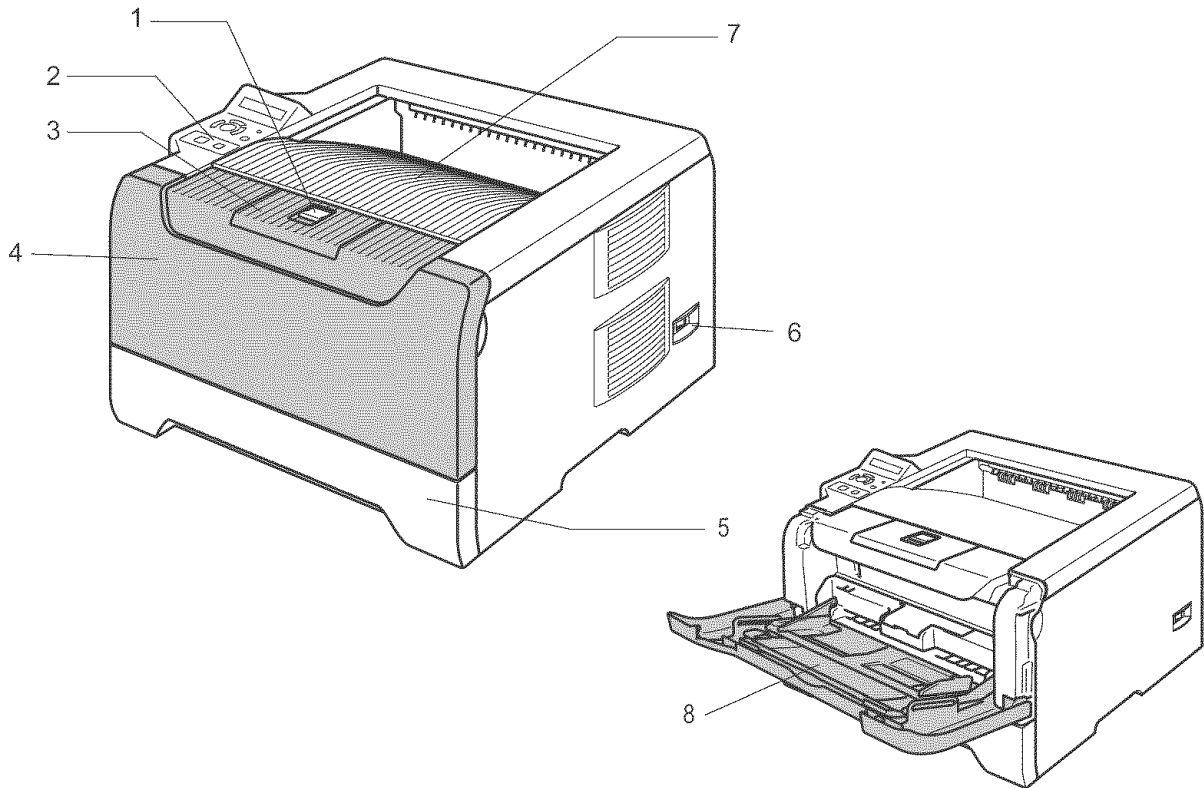

- 1 Front cover release button
- 2 Control panel
- 3 Face-down output tray support flap (support flap)
- 4 Front cover
- 5 Paper tray
- 6 Power switch
- 7 Face-down output tray
- 8 Multi-purpose Tray (MP Tray)

Back view

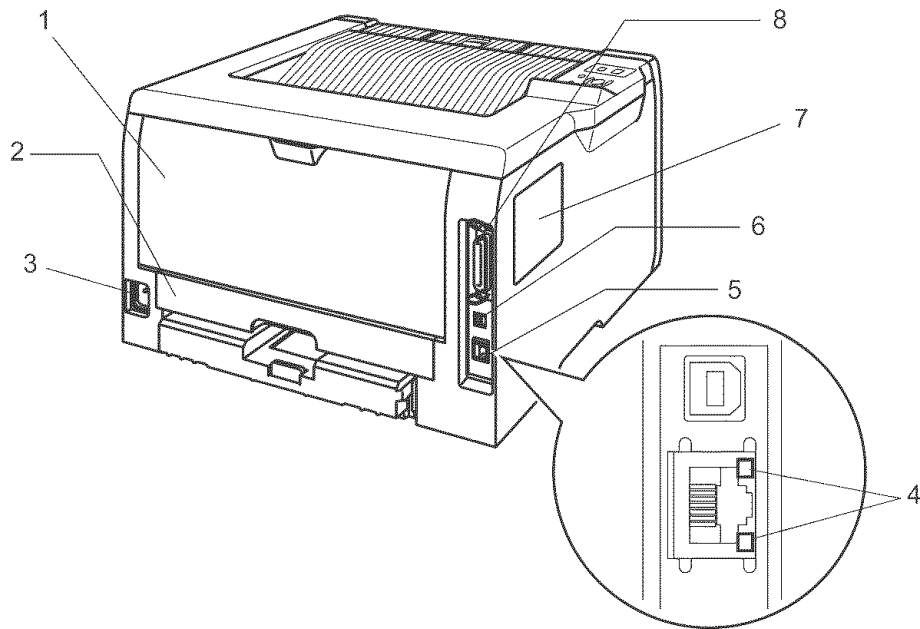

- 1 Back cover
- 2 Duplex Tray
- 3 AC power connector
- 4 LEDs (Light emitting diodes)
- 5 10/100BASE-TX port
- 6 USB interface connector
- 7 DIMM cover
- 8 Parallel interface connector

Positioning the printer

Read the following before you use the printer.

Power supply

Use the printer within the recommended power range.

Power source:	USA and Canada:	AC 110 to 120 V, 50/60 Hz
	Europe and Australia:	AC 220 to 240 V, 50/60 Hz

The power cord, including extensions, should be no longer than 5 meters (16.5 feet).

Do not share the same power circuit with other high-power appliances, such as an air conditioner, copier, shredder and so on. If you cannot avoid using the printer with these appliances, we recommend that you use a voltage transformer or a high-frequency noise filter.

Use a voltage regulator if the power source is not stable.

Environment

- Put your printer on a flat, stable surface such as a desk that is free of vibration and shocks.
- Put the printer near an AC power outlet, so that it can be easily unplugged from the AC power outlet if there is an emergency.
- Only use the printer within the following ranges of temperature and humidity:
 - Temperature: 10 °C to 32.5 °C (50 °F to 90.5 °F)
 - Humidity: 20% to 80% (without condensation)
- Use the printer in a well-ventilated room.
- DO NOT put the printer where the ventilation hole of the printer is blocked. Keep a gap of roughly 100 mm (4 in.) between the ventilation hole and the wall.
- DO NOT expose the printer to direct sunlight, excessive heat, moisture, or dust.
- DO NOT put the printer near devices that contain magnets or produce magnetic fields.
- DO NOT expose the printer to open/naked flames or salty or corrosive gasses.
- DO NOT put objects on top of the printer.
- DO NOT put the printer near heaters, air conditioners, water, chemicals or refrigerators.
- Keep the printer horizontal when you carry it.

Network features

The Brother machine can be shared on a 10/100 Mb wired Ethernet or IEEE 802.11b/802.11g wireless Ethernet network using the internal network print server in a TCP/IP environment.



Note

- If you want to use the wireless network, set it up referring to the Quick Setup Guide and the Network User's Guide on the CD-ROM we have supplied.
- For more information about the network, see the Network User's Guide.

2

Printing Methods

About paper

Type and size of paper

The printer loads paper from the installed paper tray or the multi-purpose tray.

The names for the paper trays in the printer driver and this guide are as follows:

Paper tray	Tray 1
Multi-purpose tray	MP Tray
Optional lower tray unit	Tray 2 / Tray 3
Duplex tray for automatic duplex printing	DX

When looking at this page on the CD-ROM, you can jump to the page for each printing method by clicking ⓘ in the table.

Media type	Tray 1	Tray 2/3	MP Tray	DX	Choose the media type from the printer driver
Plain paper 75 g/m ² to 105 g/m ² (20 to 28 lb)	ⓘ	ⓘ	ⓘ	ⓘ	Plain Paper
Recycled paper	ⓘ	ⓘ	ⓘ	ⓘ	Recycled Paper
Bond paper Rough paper– 60 g/m ² to 161 g/m ² (16 to 43 lb)	ⓘ 60 g/m ² to 105 g/m ² (16 to 28 lb)	ⓘ 60 g/m ² to 105 g/m ² (16 to 28 lb)	ⓘ 60 g/m ² to 161 g/m ² (16 to 43 lb)		Bond Paper
Thin paper 60 g/m ² to 75 g/m ² (16 to 20 lb)	ⓘ	ⓘ	ⓘ	ⓘ	Thin Paper
Thick paper 105 g/m ² to 161 g/m ² (28 to 43 lb)			ⓘ		Thick Paper or Thicker Paper
Transparency	ⓘ Up to 10 sheets A4 or Letter		ⓘ Up to 10 sheets A4 or Letter		Transparencies
Labels			ⓘ A4 or Letter		Thicker Paper
Envelopes			ⓘ		Envelopes Env. Thin Env. Thick

	MP Tray	Tray 1	Tray 2, Tray 3	DX
Paper size	Width: 69.9 to 215.9 mm (2.75 to 8.5 in.) Length: 116 to 406.4 mm (4.57 to 16 in.)	A4, Letter, Legal ¹ , B5 (ISO), Executive, A5, A6, B6 (ISO)	A4, Letter, Legal ¹ , B5 (ISO), Executive, A5, B6 (ISO)	A4, Letter, Legal ¹
Number of sheets (80 g/m ² / 21 lb)	50 sheets	250 sheets	250 sheets	

¹ Legal size paper is not available in some regions outside the USA and Canada.

Recommended paper

	Europe	USA
Plain paper	Xerox Premier 80 g/m ² Xerox Business 80 g/m ² M-real DATACOPY 80 g/m ²	Xerox 4200DP 20 lb Hammermill Laser Paper 24 lb
Recycled paper	Xerox Recycled Supreme 80 g/m ²	N/A
Transparency	3M CG3300	3M CG3300
Labels	Avery laser label L7163	Avery laser label #5160

- Before you buy a lot of paper, test a small quantity to make sure that the paper is suitable.
- Use paper that is made for plain-paper copying.
- Use paper that is 75 to 90 g/m² (20 to 24 lb).
- Use neutral paper. Do not use acidic or alkaline paper.
- Use long-grain paper.
- Use paper with a moisture content of approximately 5%.
- This printer can use recycled paper that meets DIN 19309 specifications.

CAUTION

DO NOT use ink jet paper because it may cause a paper jam or damage your printer.

Note

If you use paper that is not recommended, a paper jam or misfeed may occur in the printer.

To help you choose which paper to use with this printer, see *Important information for choosing your paper* on page 119.

Types of envelopes

Most envelopes will be suitable for your printer. However, some envelopes may have feed and print quality problems due to the way they have been made. A suitable envelope should have edges with straight, well-creased folds and the leading edge should not be thicker than two pieces of paper. The envelope should lie flat and not be of baggy or flimsy construction. You should buy quality envelopes from a supplier who understands that you will be using the envelopes in a laser printer. Before you print a lot of envelopes, test one to make sure that the print results are what you want.

Brother does not recommend a particular envelope because envelope manufacturers may change the envelope specifications. You are responsible for the quality and performance of the envelopes you use.

- Do not use damaged, curled, wrinkled, irregularly shaped, extremely shiny or textured envelopes.
- Do not use envelopes with clasps, snaps, tie strings, self-adhesive components, windows, holes, cutouts or perforations.
- Do not use envelopes that are of a baggy construction, not sharply creased, embossed (have raised writing on them) or pre-printed on the inside.
- Do not use envelopes that were previously printed by a laser printer.
- Do not use envelopes that cannot be arranged when put in a pile.
- Do not use envelopes that are made of paper that weighs more than the paper weight specifications for the printer.
- Do not use envelopes that have been badly made, with edges that are not straight or consistently square.

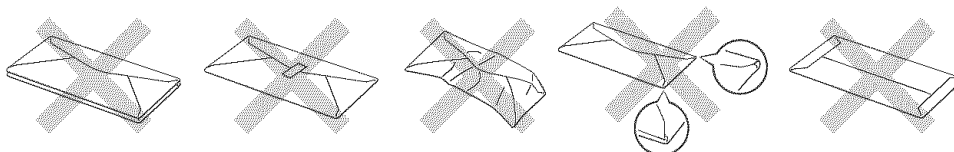

If you use any of the types of envelopes listed above, they may damage your printer. This damage is not covered under any Brother warranty or service agreement.



Note

- Do not put different types of paper in the paper tray at the same time because it may cause paper jams or misfeeds.
- Do not print envelopes using duplex printing.
- For proper printing, you must choose the same paper size from your application as the paper in the tray.

Printable area

When using PCL (standard driver) emulation, the edges of the paper that cannot be printed on are shown in the tables below.



Note

When using BR-Script emulation, the edges of the paper that cannot be printed on are 4.32 mm (0.17 in.).

Portrait

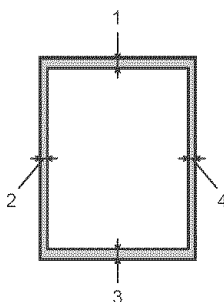

	A4	Letter	Legal	B5 (ISO)	Executive	A5	A6	B6
1	4.23 mm (0.16 in.)	4.23 mm (0.16 in.)	4.23 mm (0.16 in.)	4.23 mm (0.16 in.)	4.23 mm (0.16 in.)	4.23 mm (0.16 in.)	4.23 mm (0.16 in.)	4.23 mm (0.16 in.)
2	6.01 mm (0.24 in.)	6.35 mm (0.25 in.)	6.35 mm (0.25 in.)	6.01 mm (0.24 in.)	6.35 mm (0.25 in.)	6.01 mm (0.24 in.)	6.01 mm (0.24 in.)	6.01 mm (0.24 in.)
3	4.23 mm (0.16 in.)	4.23 mm (0.16 in.)	4.23 mm (0.16 in.)	4.23 mm (0.16 in.)	4.23 mm (0.16 in.)	4.23 mm (0.16 in.)	4.23 mm (0.16 in.)	4.23 mm (0.16 in.)
4	6.01 mm (0.24 in.)	6.35 mm (0.25 in.)	6.35 mm (0.25 in.)	6.01 mm (0.24 in.)	6.35 mm (0.25 in.)	6.01 mm (0.24 in.)	6.01 mm (0.24 in.)	6.01 mm (0.24 in.)

Landscape

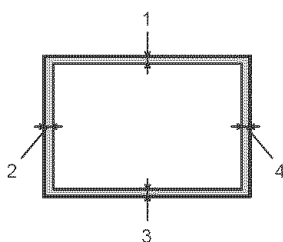

	A4	Letter	Legal	B5 (ISO)	Executive	A5	A6	B6
1	4.23 mm (0.16 in.)	4.23 mm (0.16 in.)	4.23 mm (0.16 in.)	4.23 mm (0.16 in.)	4.23 mm (0.16 in.)	4.23 mm (0.16 in.)	4.23 mm (0.16 in.)	4.23 mm (0.16 in.)
2	5.0 mm (0.19 in.)	5.08 mm (0.2 in.)	5.08 mm (0.2 in.)	5.0 mm (0.19 in.)	5.08 mm (0.2 in.)	5.0 mm (0.19 in.)	5.0 mm (0.19 in.)	5.0 mm (0.19 in.)
3	4.23 mm (0.16 in.)	4.23 mm (0.16 in.)	4.23 mm (0.16 in.)	4.23 mm (0.16 in.)	4.23 mm (0.16 in.)	4.23 mm (0.16 in.)	4.23 mm (0.16 in.)	4.23 mm (0.16 in.)
4	5.0 mm (0.19 in.)	5.08 mm (0.2 in.)	5.08 mm (0.2 in.)	5.0 mm (0.19 in.)	5.08 mm (0.2 in.)	5.0 mm (0.19 in.)	5.0 mm (0.19 in.)	5.0 mm (0.19 in.)

Printing methods

Printing on plain paper, bond paper and transparencies

Printing on plain paper, bond paper or transparencies from Tray 1, 2 or 3

For the proper paper to use, see *About paper* on page 6.

1 Choose the following from the printer driver:

Paper Size (1)

Media Type (2)

Paper Source (3)

and any other settings.

■ Windows printer driver

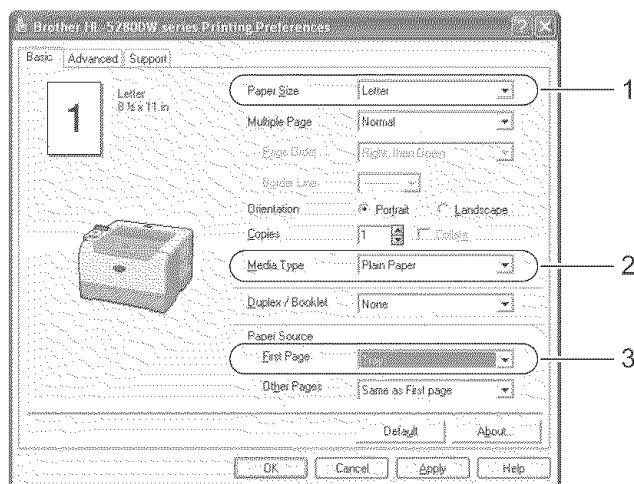

■ BR-Script printer driver

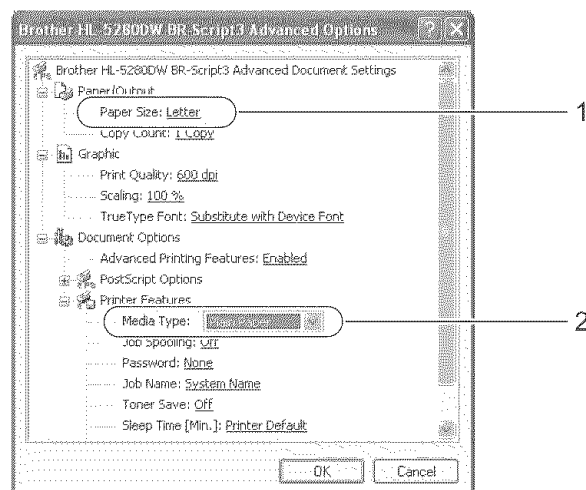
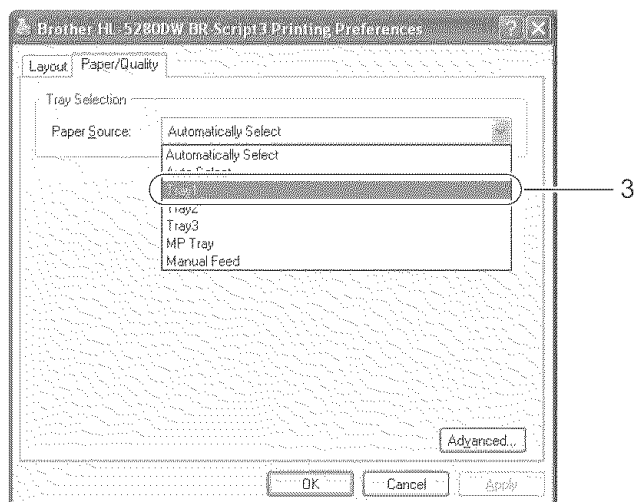

- 2 Pull the paper tray completely out of the printer.

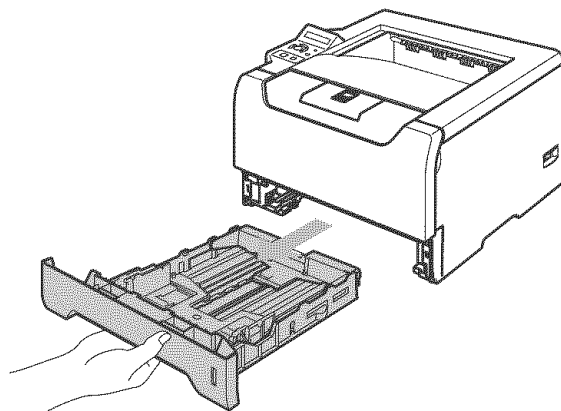

- 3 While pressing the blue paper-guide release lever, slide the paper guides to fit the paper size. Make sure that the guides are firmly in the slots. For legal size paper¹, press in the paper-guide release lever and pull out the back of the paper tray.

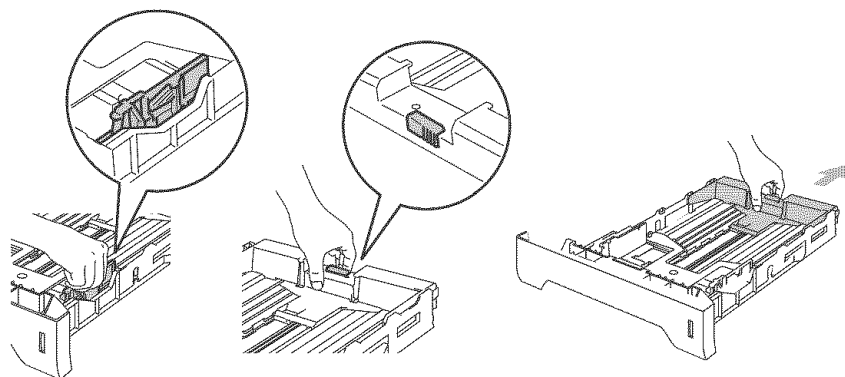

¹ Legal size paper is not available in some regions outside the USA and Canada.

- 4 Put paper in the tray, and make sure that the paper is below the maximum paper mark (▼).

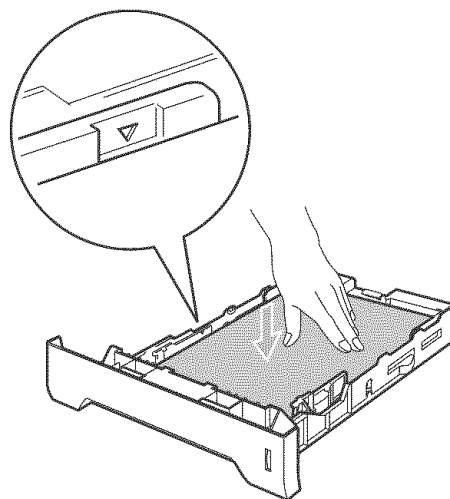

- 5 Put the paper tray firmly back in the printer. Make sure that it is completely inserted into the printer.
- 6 Lift up the support flap to prevent paper from sliding off the face-down output tray, or remove each page as soon as it comes out of the printer.

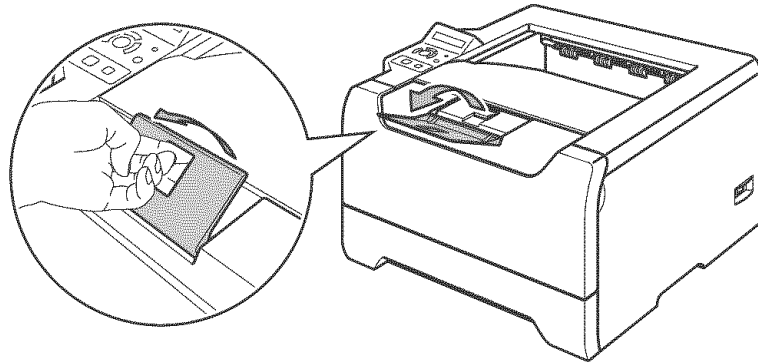

- 7 Send the print data to the printer.



Note

- The side to be printed on must be face down.
- When printing on transparencies, remove each transparency at once after printing. Stacking the printed transparencies may cause a paper jam or the transparency to curl.

Printing on plain paper, bond paper or transparencies from the MP tray

MP Tray mode is automatically turned on when paper is put in the multi-purpose tray.

For the proper paper to use, see *About paper* on page 6.

1 Choose the following from the printer driver:

Paper Size (1)

Media Type (2)

Paper Source (3)

and any other settings.

■ Windows printer driver

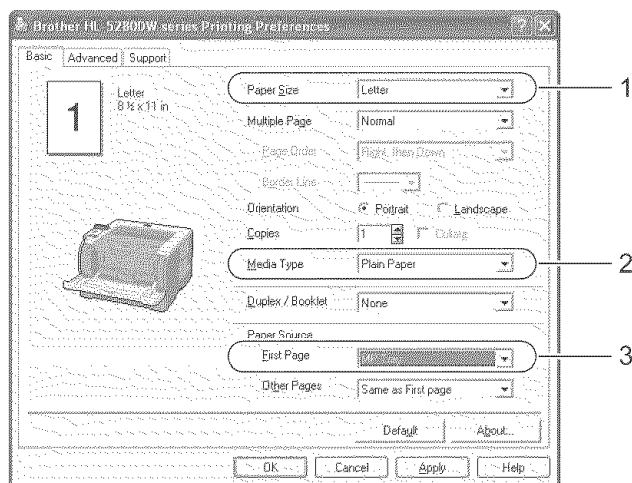

■ BR-Script printer driver

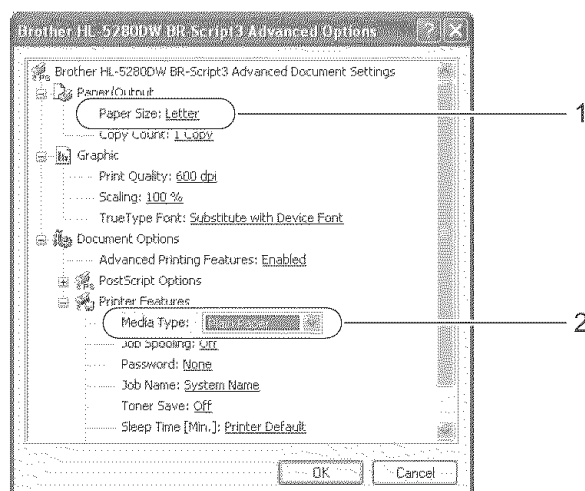
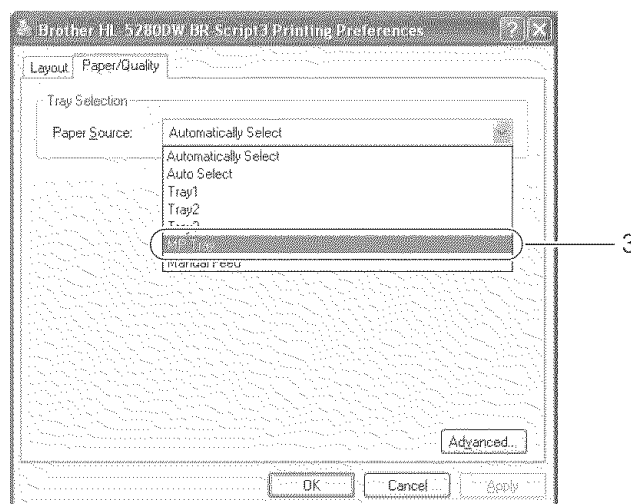

- 2 Open the MP tray and lower it gently.

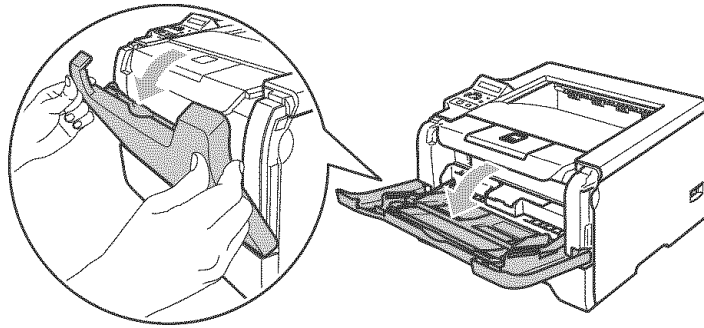

- 3 Pull out the MP tray support flap (1).

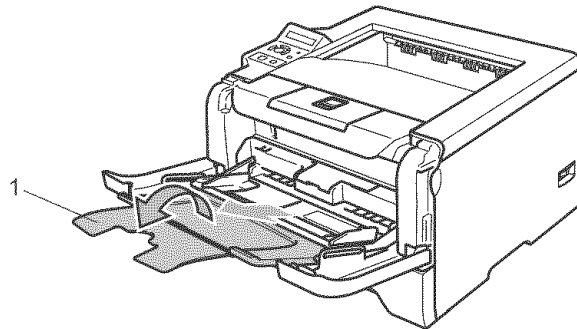

- 4 Lift up the support flap to prevent paper from sliding off the face-down output tray, or remove each page as soon as it comes out of the printer.

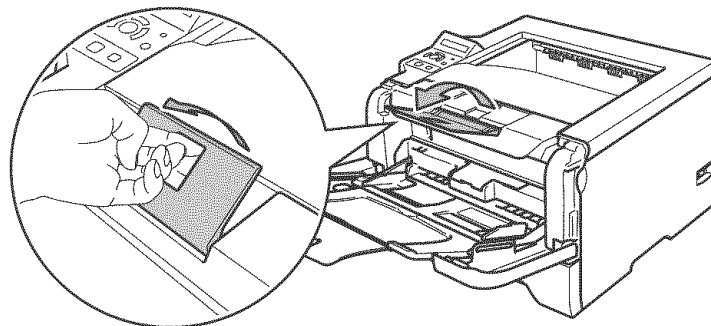

- 5 Put paper in the MP tray. Make sure that the paper stays under the maximum paper mark (▼) on both sides of the tray.

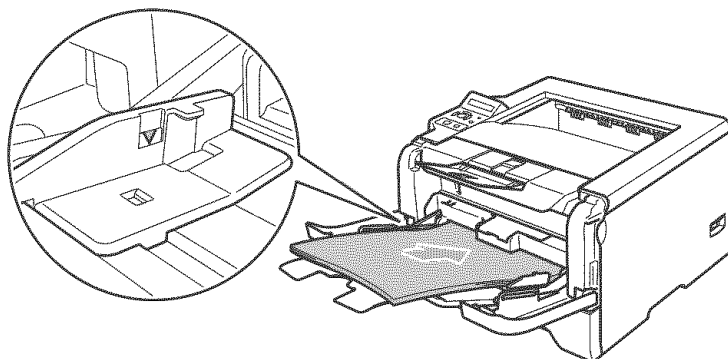

- 6 While pressing the paper-guide release lever, slide the paper guide to fit the paper size.

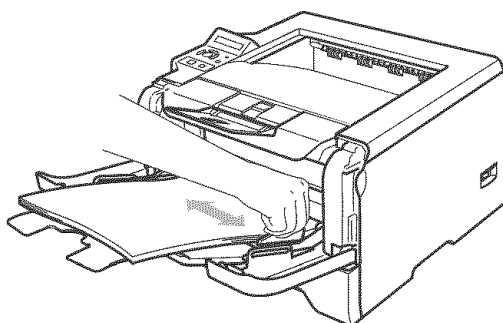

- 7 Send the print data to the printer.

**Note**

-
- The side to be printed on must be face up with the leading edge (top of the paper) in first.
 - When printing on transparencies, remove each transparency at once after printing. Stacking the printed transparencies may cause a paper jam or the transparency to curl.
-

Printing on thick paper, labels and envelopes

MP Tray mode is automatically turned on when paper is put in the multi-purpose tray.
For the proper paper to use, see *About paper* on page 6 and *Types of envelopes* on page 8.

1 Choose the following from the printer driver:

Paper Size (1)

Media Type (2)

Paper Source (3)

and any other settings.

■ Windows printer driver

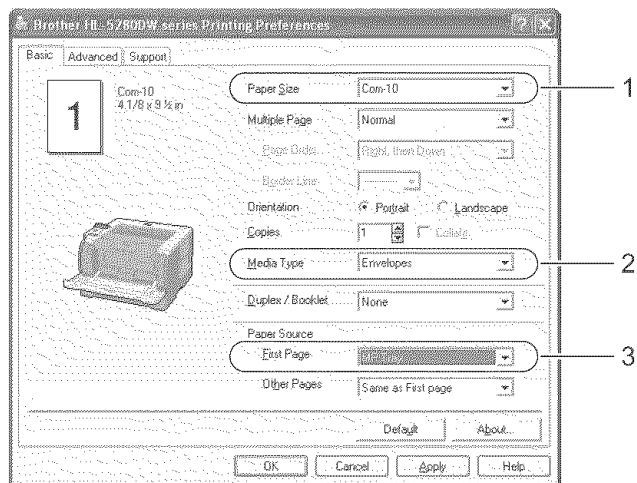

■ BR-Script printer driver

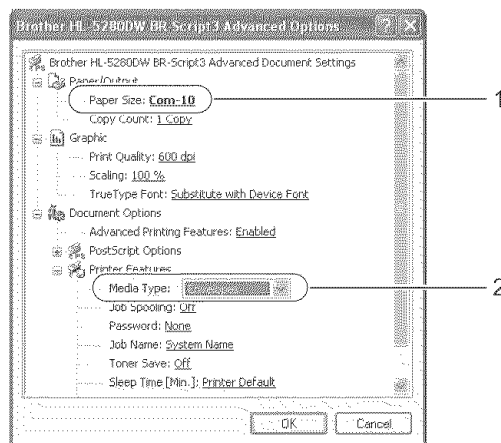
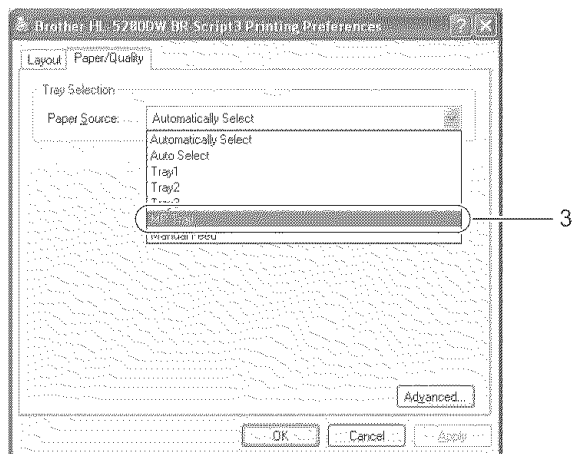

Note

- When you use Envelope #10, choose **Com-10** in **Paper Size**.
- For other envelopes which are not listed in the printer driver, such as Envelope #9 or Envelope C6, choose **User Defined...** For more information on the envelope size, see *Paper size* on page A-8.

- 2 Open the MP tray and lower it gently.

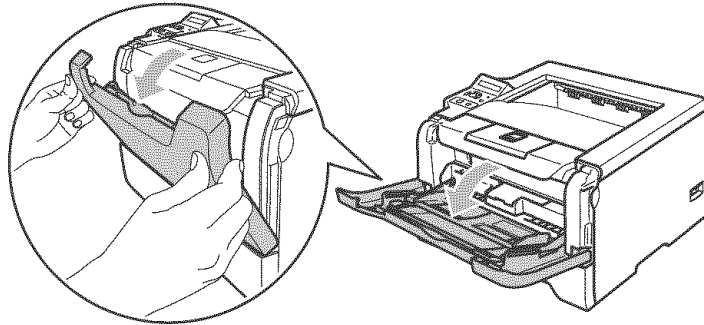

- 3 Pull out the MP tray support flap (1).

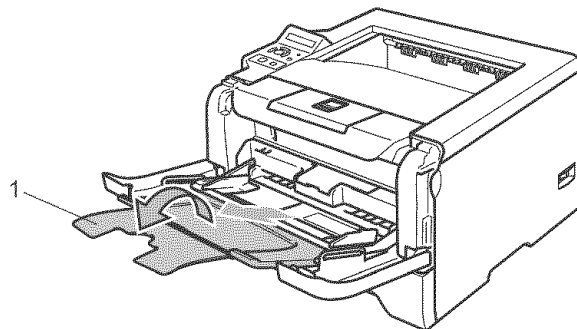

- 4 Lift up the support flap to prevent paper from sliding off the face-down output tray, or remove each page as soon as it comes out of the printer.

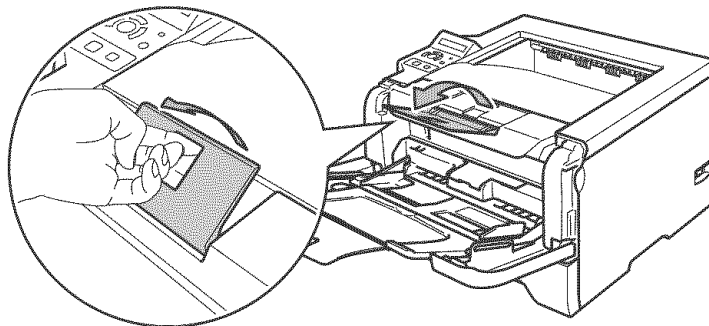

- 5 Put paper in the MP tray. Make sure that the paper stays under the maximum paper mark (▼) on both sides of the tray.

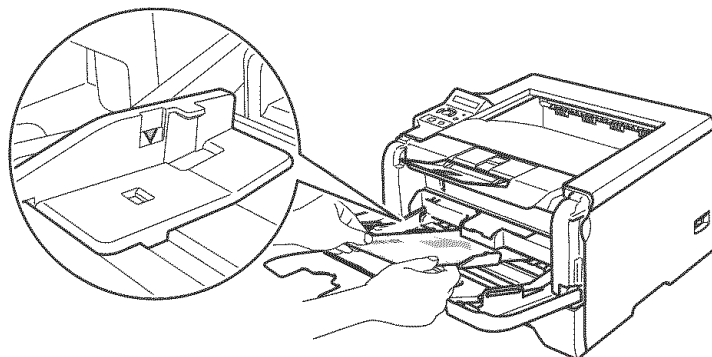

 **Note**

- Envelope joints that are sealed by the manufacturer should be secure.
- The side to be printed on must be face up.
- All sides of the envelope should be properly folded without wrinkles or creases.

- 6 While pressing the paper-guide release lever, slide the paper guide to fit the paper size.

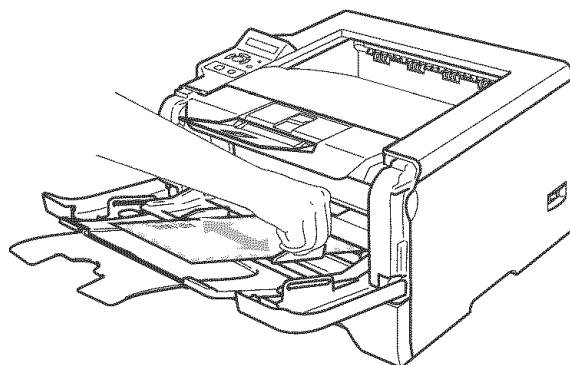

- 7 Send the print data to the printer.

 **Note**

- Remove each sheet or envelope at once after printing. Stacking the sheets or envelopes may cause the paper to jam or curl.
- If envelopes get smudged during printing set the **Media Type** to **Thick Paper** or **Thicker Paper** to increase the fixing temperature. To adjust the print density setting, see *Printing on thick paper, labels and envelopes* on page 16.
- If the envelopes is creased after they are printed, see *Improving the print quality* on page 105.

 **Note**

- If the DL size double flap envelope is created after printing, choose **DL Long Edge** in **Paper Size**, from the **Basic** tab. Put a new DL size double-flap envelope in the MP tray with the longest edge of the envelope in first, then print again.

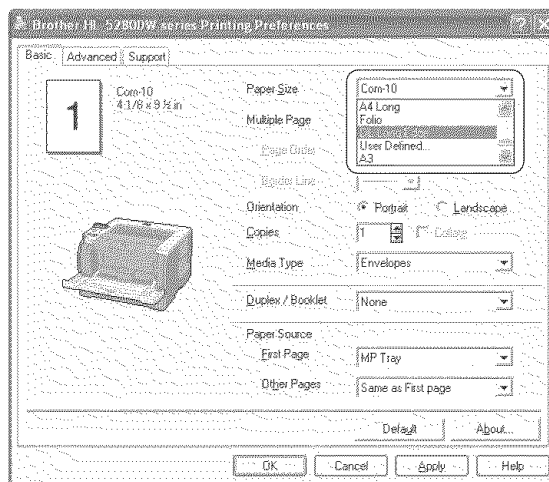

- When you put paper in the MP tray, remember the following:
 - Put the leading edge (top of the paper) in first and push it gently into the tray.
 - Make sure that the paper is straight and in the proper position in the MP tray. If it is not, the paper may not be fed properly, resulting in a skewed printout or a paper jam.

Duplex Printing

The supplied printer drivers for Windows® 95/98/Me/2000/XP and Windows NT® 4.0, Mac OS® 9.1 to 9.2 and Mac OS® X 10.2.4 or greater all enable duplex printing. For more information about how to choose the settings, see the **Help** text in the printer driver.

Guidelines for printing on both sides of the paper

- If the paper is thin, it may wrinkle.
- If paper is curled, straighten it and then put it back in the paper tray or the MP tray.
- If the paper is not feeding properly, it may be curled. Remove the paper and straighten it.
- When you use the manual duplex function, it is possible that there may be paper jams or poor print quality. If there is a paper jam, see *Paper jams and how to clear them* on page 96. If you have a print quality problem, see *Improving the print quality* on page 105.

Manual duplex printing

- The BR-Script printer driver (PostScript® 3™ emulation) does not support manual duplex printing.
- Use plain paper or recycled paper. Do not use bond paper.

Manual duplex printing from the paper tray

- 1 In the printer driver choose the **Advanced** tab, then choose the **Manual Duplex** printing mode, and from the **Basic** tab choose the **Paper Source** to be **Tray1**.
- 2 Send the data to the printer.
The printer will automatically print all the even-numbered pages on one side of the paper first.
- 3 Remove the printed even-numbered pages from the output tray and put them back in the paper tray with the side to be printed on (blank side) face down. Follow the instructions on the PC screen.

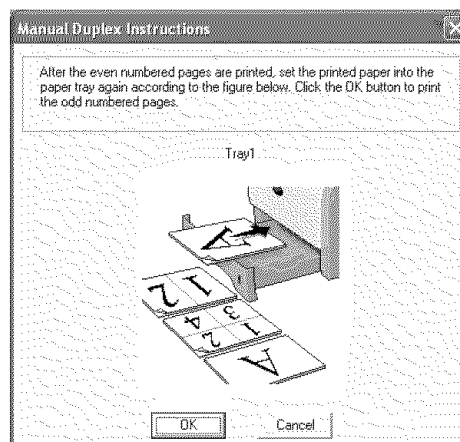
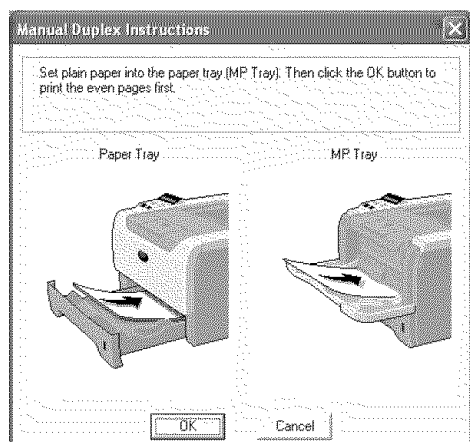

- 4 The printer will now automatically print all the odd-numbered pages on the other side of the paper.

 **Note**

- If you choose the **Paper Source** to be **Auto Select**, put the printed even-numbered pages in the MP tray.
- When you put paper in the paper tray, first empty the tray. Next, put the printed pages in the tray, with the printed side face up. (Do not add the printed pages to the top of a stack of unprinted paper.)

Manual duplex printing from the MP tray

 **Note**

Before putting the sheets back in the MP tray, you will have to straighten them, or you may get paper jams.

- 1 From the **Advanced** tab choose the **Manual Duplex** printing mode, and from the **Basic** tab choose the **Paper Source** to be **MP Tray**.
- 2 Put the paper in the MP tray with the side to be printed on first facing up. Follow the instructions on the PC screen. Repeat this step until you have printed all the even-numbered pages.

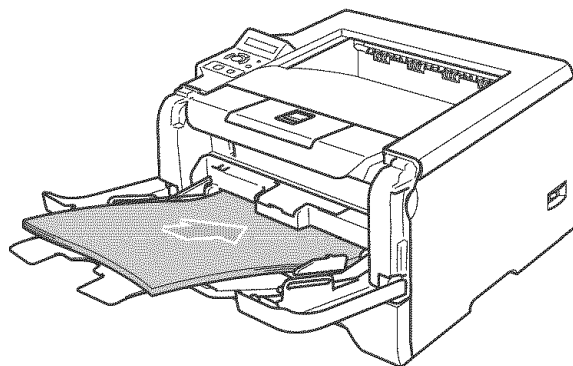

- 3 Remove the printed even-numbered pages from the output tray and then, in the same order, put them back into the MP tray. Put the paper with the side to be printed on (the blank side) face up. Follow the instructions on the PC screen.

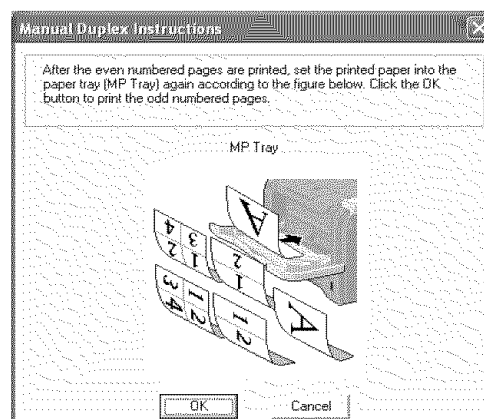
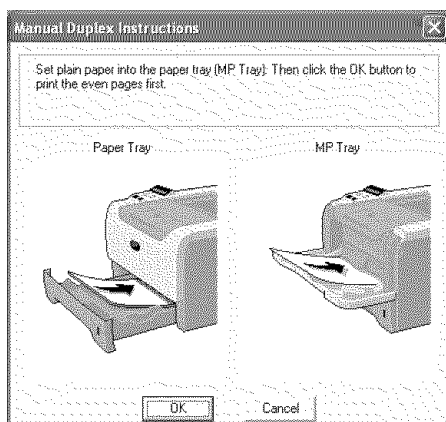

- 4 Repeat 3 until you have printed all the odd-numbered pages on the other side of the paper.

Paper orientation for manual duplex printing

The printer prints the second page first.

If you print 10 pages on 5 sheets of paper, it will print page 2 and then page 1 on the first sheet of paper. It will print page 4 and then page 3 on the second sheet of paper. It will print page 6 and then page 5 on the third sheet of paper, and so on.

When doing manual duplex printing, the paper must be put in the paper tray in the following way:

- For the paper tray:
 - Put the side to be printed on face down with the leading edge (top) of the paper at the front of the tray.
 - To print on the second side, put the paper face up, with the leading edge (top) of the paper at the front of the tray.
 - If letterhead paper is used, put the paper in the tray with the heading face up at the front of the tray.
 - To print on the second side, put the heading face down at the front of the tray.
- For the multi-purpose tray (MP tray):
 - Put the side to be printed on face up with the leading edge (top) of the paper in first.
 - To print on the second side, put the paper face down, with the leading edge (top) of the paper in first.
 - If letterhead paper is used, put it in with the heading face down and in first.
 - To print on the second side, put the heading face up and in first.

Automatic duplex printing



Note

- The screens in this section are from Windows® XP. The screens on your PC may vary depending on your operating system.
- Use A4, Letter or Legal size paper when you use the automatic duplex printing function.
- Make sure that the back cover is closed.
- Make sure that the duplex tray is installed correctly in the printer.
- If paper is curled, straighten it and then put it back in the paper tray.
- You should use regular paper. Do not use bond paper or thin paper.

① Put paper in the paper tray or MP tray.

② For the Windows printer driver

- 1 Open the **Properties** dialog box in the printer driver.
- 2 From the **General** tab, click the **Printing Preferences** icon.
- 3 From the **Advanced** tab, click the **Duplex** icon.
- 4 Make sure that **Use Duplex Unit** has been chosen.

- Click **OK**. The printer will print on both sides of the paper automatically.

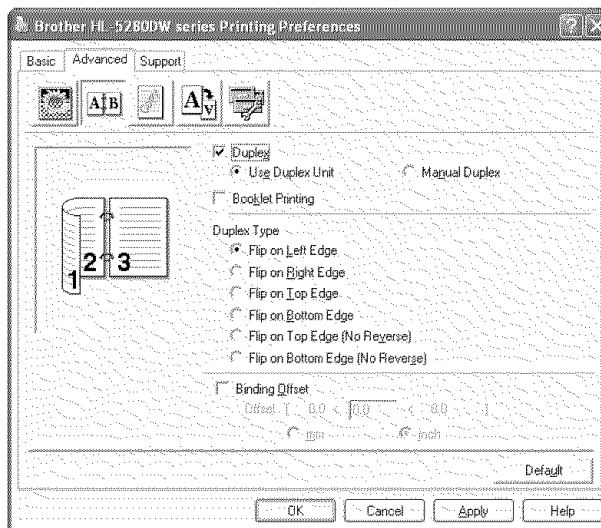

For the BR-Script printer driver

- Open the **Properties** dialog box in the printer driver.
- From the **General** tab, click the **Printing Preferences** icon.
- From the **Layout** tab, choose **Orientation**, **Print on Both Sides (Duplex)** and **Page Order**.
- Click **OK**. The printer will print on both sides of the paper automatically.

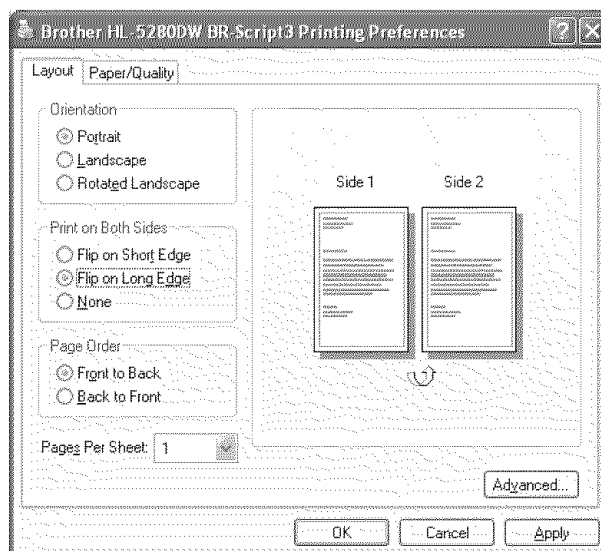

Booklet printing (For Windows printer driver)

- 1 Put paper in the paper tray or MP tray.
- 2 Open the **Properties** dialog box in the printer driver.
- 3 From the **General** tab, choose the **Printing Preferences** icon.
- 4 From the **Advanced** tab, choose **Duplex** and **Use Duplex Unit** or **Manual Duplex**, and then choose **Booklet Printing**.
- 5 Click **OK**. The printer will print a booklet automatically.

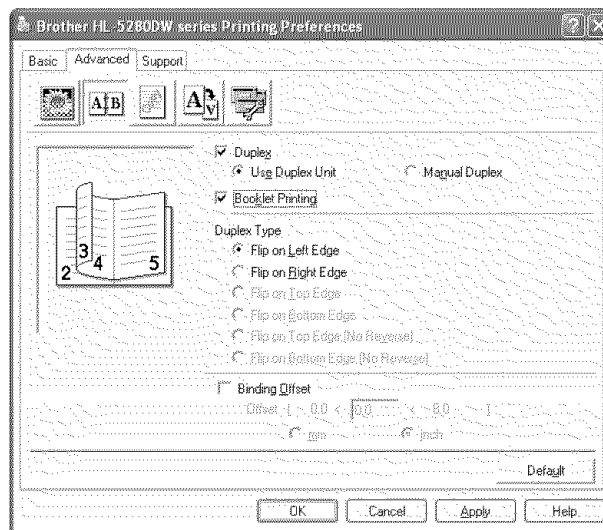

Carbon copy printing

Carbon copy printing allows you to automatically print one page of data on different kinds of paper by changing the paper source. You can make copies as though you are printing on carbon paper using a dot matrix printer. For example, you can print 'Data A' to 'Sheet 1' which is blue colored paper and then to 'Sheet 2' which is yellow colored and has some information already printed on it. If you put paper for 'Sheet 1' in Tray 1 and paper for 'Sheet 2' in the MP tray, the printer will automatically feed paper for 'Sheet 1' from Tray 1 and 'Sheet 2' from the MP tray.

For more information, visit us at http://solutions.brother.com/carboncopy/en_us

Printer driver

A printer driver is software that translates data from the format used by a computer to the format that a particular printer needs. Typically, this format is page description language (PDL).

The printer drivers for the following versions of Windows® and Macintosh® are on the CD-ROM we have supplied or on the Brother Solutions Center at <http://solutions.brother.com>. Install the drivers by following the Quick Setup Guide. The latest printer driver can be downloaded from the Brother Solutions Center at <http://solutions.brother.com>.

If you want to uninstall the printer driver, see *Uninstalling the printer driver* on page 42.

For Windows®

- Windows printer driver (the most suitable printer driver for this product)
- BR-Script (PostScript® 3™ language emulation) printer driver
- Generic PCL Driver (For users of Citrix Presentation Server™ (Citrix® MetaFrame®), Windows® Terminal Server environments and other Windows NT 4.0® and Windows® 2000/XP network shared environments, we recommend the use of our generic PCL Driver. This driver only supports basic printing functions.)

For Macintosh®

- Brother Laser driver for Macintosh®
- BR-Script (PostScript® 3™ language emulation) printer driver

For Linux

- LPR printer driver
- CUPS printer driver



Note

- For more information about the generic PCL Driver and Linux printer driver, visit us at <http://solutions.brother.com>.
- The printer driver for Linux may be released after the initial release of this product.

	Windows printer driver	BR-Script printer driver	Generic PCL Driver ¹	Brother Laser driver	LPR / CUPS printer driver
Windows® 95/98/Me	ⓘ	ⓘ			
Windows NT® 4.0 Windows® 2000 Professional Windows® XP Home Edition Windows® XP Professional	ⓘ	ⓘ	ⓘ		
Windows® XP Professional x64 Edition ¹	ⓘ	ⓘ			
Mac OS® 9.1 to 9.2 Mac OS® X 10.2.4 or greater		ⓘ		ⓘ	
Linux (Mandrake, Red Hat, SuSE Linux, Debian) ¹					ⓘ

¹ Download the printer driver from <http://solutions.brother.com>.

You can change the following printer settings when you print from your computer.

- Paper Size
- Multiple Page
- Orientation
- Copies
- Media Type
- Paper Source
- Resolution
- Toner Save Mode
- Duplex printing (Manual Duplex printing ^{1 3} / Duplex printing with Duplex tray)
- Watermark ^{1 3}
- Job Spooling ^{1 3}
- Quick Print Setup ^{1 3}
- Sleep Time
- Status Monitor ¹
- Macro ^{1 3}
- Administrator ^{1 2 3}
- Insert Command/File ^{1 2 3}
- Page Protection ^{1 3}
- Print Date & Time ^{1 3}
- Density adjustment ^{1 3}
- Error Message Printout ^{1 3}

¹ These settings are not available with the BR-script printer driver for Windows®.

² These settings are not available with Windows NT® 4.0 and Windows® 2000/XP.

³ These settings are not available with Brother Laser driver and BR-Script printer driver for Macintosh®.

Features in the printer driver (For Windows®)

For more information, see the **Help** text in the printer driver.

Note

- The screens in this section are from Windows® XP. The screens on your PC will vary depending on your operating system.
- If you are using Windows® 2000 or XP, you can access the **Printing Preferences** dialog box by clicking **Printing Preferences...** in the **General** tab of the **Printer Properties** dialog box.
- If you are using Windows NT® 4.0, you can access the **Printing Preferences** dialog box by clicking **Document Defaults...** from the **File** menu of the **Printers** folder.

Basic tab

You can also change some of the settings by clicking the illustrations on the left hand side.

- 1 Choose the **Paper Size, Multiple Page, Orientation** and other settings (1).
- 2 Choose the **Duplex / Booklet** setting from **None, Duplex** or **Booklet** (2).

Note

You can choose more detailed settings for Duplex or Booklet printing in the the **Advanced** tab. See *Duplex Printing* on page 30.

- 3 Choose the **Paper Source** (3).
- 4 Click **OK** to apply your chosen settings.
To return to the default settings, click **Default**, then **OK**.

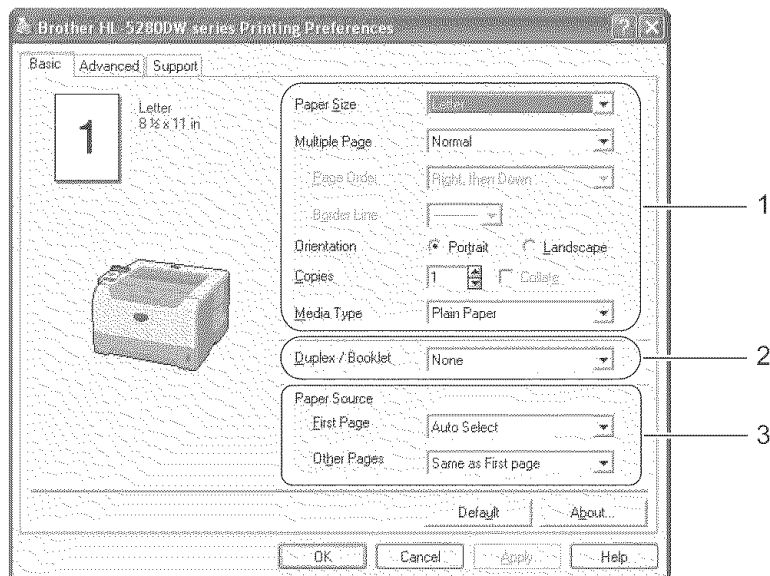

Advanced tab

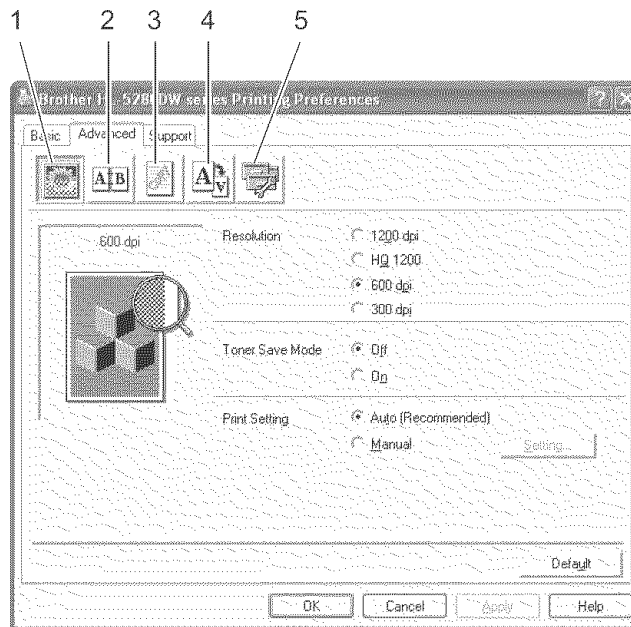

Change the tab settings by clicking one of the following icons:

- Print Quality (1)
- Duplex Printing (2)
- Watermark (3)
- Page Setting (4)
- Device Options (5)

Print Quality

■ Resolution

You can change the resolution as follows:

- 1200 dpi
- HQ 1200
- 600 dpi
- 300 dpi



Note

If you use the high quality 1200 dpi setting (1200 × 1200 dpi) the print speed will be slower.

■ Toner Save Mode

You can save running costs by turning on the **Toner Save Mode**, which cuts the print density.



Note

- We do not recommend Toner Save for printing Photo or Gray Scale images.
- **Toner Save Mode** is not available for **1200 dpi** or **HQ 1200** resolution.

■ Print Setting

You can manually change the print setting.

• Auto

Choosing **Auto** will allow automatic printing with the most suitable print settings for your print job.

• Manual

You can change the settings manually by choosing **Manual** and clicking the **Setting...** button.

You can set brightness, contrast and other settings.

Duplex Printing

■ Use Duplex Unit

If you choose **Use Duplex Unit** button, the dialog box for the duplex settings will appear. There are six types of duplex binding directions available for each orientation, automatically.

■ Manual Duplex

If you choose **Manual Duplex** button, the dialog box for the manual duplex settings will appear. There are six types of manual duplex binding directions available for each orientation.

■ Booklet Printing

When you want to print a booklet, use this function. To make the Booklet, fold the printed pages down the middle, when using the booklet printing function.

■ Binding Offset

If you check the Binding Offset option, you can also specify the offset for binding in inches or millimeters.

Watermark

You can put a logo or text into your documents as a watermark.

You can choose one of the preset watermarks, or you can use a bitmap file or text file that you have created.

When you use a bitmap file as a watermark, you can change the size of the watermark and put it anywhere you like on the page.

When you use text as a watermark, you can change the font, darkness and angle settings.

Page Setting

You can change the print image scaling and choose **Mirror/Reverse print** options.

Device Options

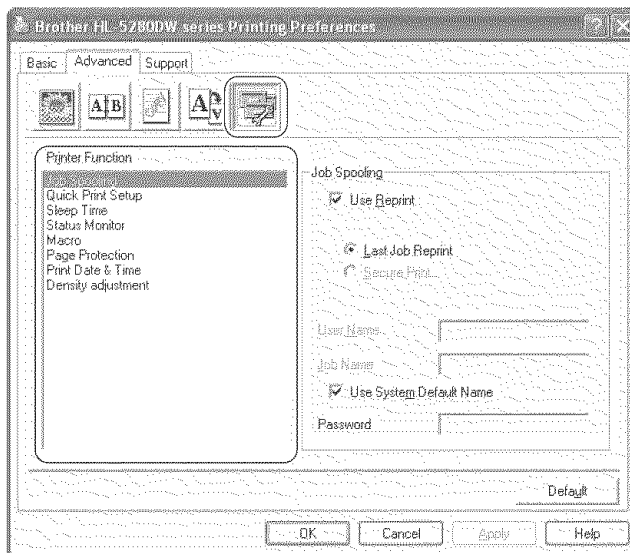

You can set the following in **Printer Function**:

(You can jump to the page for each **Printer Function** by choosing the function name in the list below.)

- Job Spooling
- Quick Print Setup
- Sleep Time
- Status Monitor
- Macro
- Administrator (For Windows® 95/98/Me only)
- Insert Command/File (For Windows® 95/98/Me only)
- Page Protection
- Print Date & Time
- Density adjustment
- Error Message Printout

■ Job Spooling

The printer keeps the last print job sent to it in memory.

You can reprint a document without sending the data again from your PC. To reprint (except for secure printing).

- Last Job Reprint: Reprint the last job
- Secure Print: Print data with a password

For more information about the Reprint function, see *Reprinting documents* on page 52.



Note

If you want to prevent other people from printing your data using the reprint function, uncheck the **Use Reprint** check box in the job spooling settings.

■ Quick Print Setup

This feature allows you to quickly choose driver settings. To view settings, click the tasktray icon.

You can turn the quick print setup function on or off. A small selection window appears on your PC. This will then let you make changes to the settings of the following functions:

- Multiple Page
- Duplex Printing
- Toner Save Mode
- Paper Source
- Media Type

■ Sleep Time

When the printer does not receive data for a certain period of time, it enters sleep mode. In sleep mode, the printer acts as though it were turned off. When you choose **Printer Default** the timeout setting will be 5 minutes. Intelligent Sleep Mode automatically adjusts to the most suitable timeout setting depending on the frequency of your printer use. While the printer is in sleep mode, the LCDs light is off, but the printer can still receive data. Receiving a print file or document or pressing one of the buttons will automatically wake up the printer to start printing.

To turn sleep mode off, from the **Advanced** tab, click the **Device Options** icon and choose **Sleep Time**. Double-click the word **Sleep Time**, and the Sleep Time Off function will appear. Click **Off** to stop the printer going into sleep mode. The Sleep Time Off function can be hidden by double-clicking the word Sleep Time again. We recommend that you keep sleep mode on for power saving.

■ Status Monitor

This reports the printer status (any errors that may happen with the printer) when printing. The default setting for the Status Monitor is off. If you want to turn the status monitor on, from the **Advanced** tab, click the **Device Options** icon and then choose **Status Monitor**.

■ Macro

You can save a page of a document as a macro to printer memory. You can also execute the saved macro (you can use the saved macro as an overlay on any documents). This will save time and increase printing speed for often used information such as forms, company logos, letterhead formats or invoices.

■ Administrator (For Windows® 95/98/Me only)

Administrators have the authority to limit the number of copies, scaling setting and watermark setting functions.

- Password

Enter the password into this box.

- Set Password

Click here to change the password.

- COPY LOCK

Lock the copy pages selection to prevent multiple copy printing.

- WATERMARK LOCK

Lock the current settings of the Watermark option to prevent changes being made.

- SCALING LOCK

Lock the scaling setting as shown below:

1 in 1
100%

■ Insert Command/File (For Windows® 95/98/Me only)

This function lets you to do the following:

- Put a print file or tiff format file into a print job.
- Put a text string into a print job.
- Put a macro, which is saved in printer memory, into a print job.

■ Page Protection

Page Protection refers to a setting that reserves extra memory for the creation of full-page images.

Selections are **AUTO**, **OFF** and **Printer Default**.

The page protection feature allows the printer to create the full-page image to be printed in memory before physically moving the paper through the printer. Use this function when the image is complicated and the printer has to wait to process the image before printing.

■ Print Date & Time

When this feature is enabled, the date and time will print on your document.

■ Density adjustment

Increase or decrease the print density.



Note

The **Density adjustment** is not available when you set the **resolution** to **HQ 1200**.

■ Error Message Printout

You can choose whether the printer reports problems by printing an error page. For details, see *Error message printout* on page 94.

Selections are **Printer Default** (OFF), **ON** and **OFF**.

Accessories tab

Note

From the **Start** menu, select **Control Panel** and then **Printers** ¹. Right-click the **Brother HL-5270DN/5280DW series** icon and select **Properties** to access the **Accessories** tab.

¹ **Printers and Faxes** for Windows® XP users.

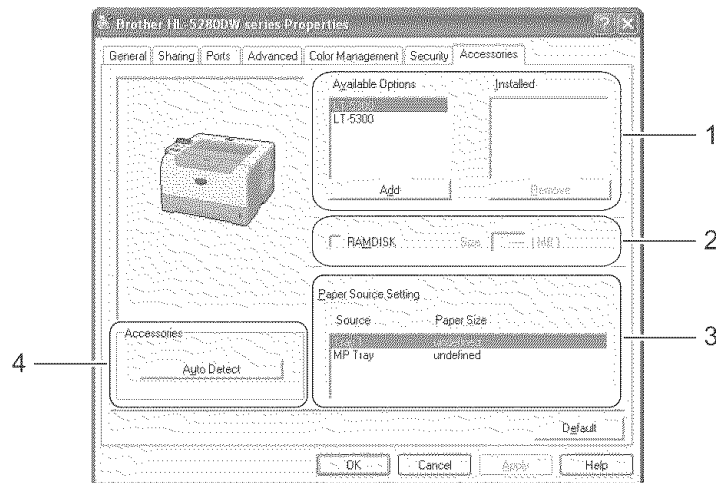

■ Available Options (1)

You can manually add and remove the options that are installed on the printer. Tray settings will match the installed options.

■ RAMDISK (2)

You can detect the capacity of the RAMDISK that has been set using the control panel. To find the capacity of RAMDISK, check the RAMDISK check box and then click Auto Detect. For more information, see *Reprinting from RAM* on page 52.

■ Paper Source Setting (3)

This feature recognizes the paper size in each paper tray.

■ Auto detection of printer options (4)

The **Auto Detect** function finds the currently installed optional unit devices and shows the available settings in the printer driver. When you click **Auto Detect**, options that are installed on the printer will be listed. You can manually add or remove options.

Note

The **Auto Detect** function is not available under certain printer conditions.

Support tab

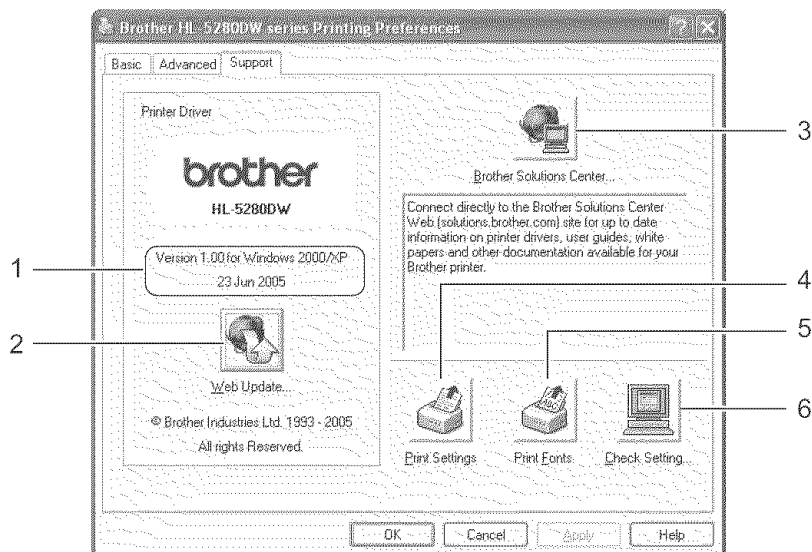

■ Version (1)

Displays the printer driver version.

■ Web Update (2)

You can check the Brother web site for updated drivers, and automatically download and update the printer driver on your PC.

■ Brother Solutions Center (3)

The Brother Solutions Center (<http://solutions.brother.com>) is a web site offering information about your Brother product including FAQs (Frequently Asked Questions), User's Guides, driver updates and tips for using your printer.

■ Print Settings (4)

This will print the pages that show how the internal settings of the printer have been configured.

■ Print Fonts (5)

This will print the pages that show all the internal fonts of the printer.

■ Check Setting... (6)

This will show the current settings of the printer driver.

Features in the BR-Script (PostScript® 3™ language emulation) printer driver (For Windows®)

For more information, see the **Help** text in the printer driver.

Note

The screens in this section are based on HL-5270DN with Windows® XP.

The screens on your PC may vary depending on the printer model and your operating system.

Device Settings tab

Choose the options you have installed.

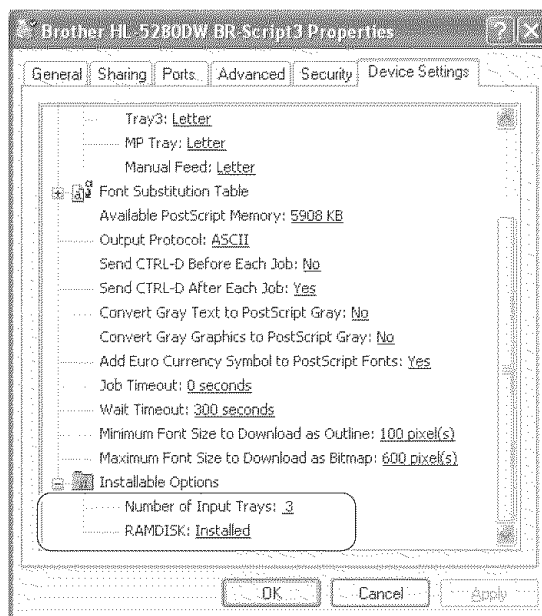

Printing Preferences

Note

If you are using Windows NT® 4.0, Windows® 2000 or XP, you can access the Printing Preferences dialog box by clicking **Printing Preferences...** in the **General** tab of the **Brother HL-5270DN/HL-5280DW BR-Script3 Properties** dialog box.

Layout tab

You can change the layout setting by choosing the settings for **Orientation**, **Print on Both Sides** (Duplex), **Page Order** and **Pages Per Sheet**.

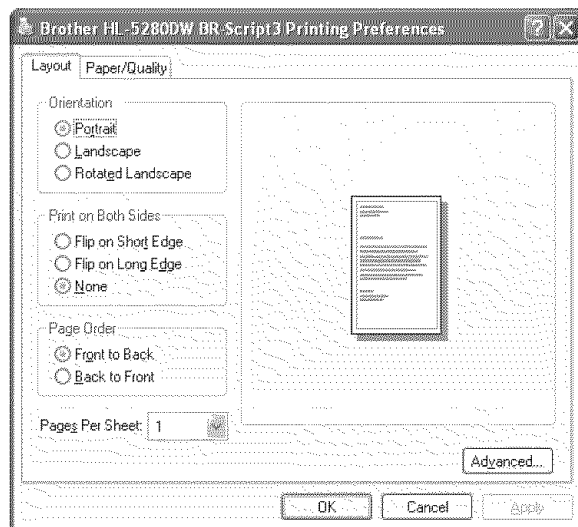

Paper/Quality tab

Choose the **Paper Source**.

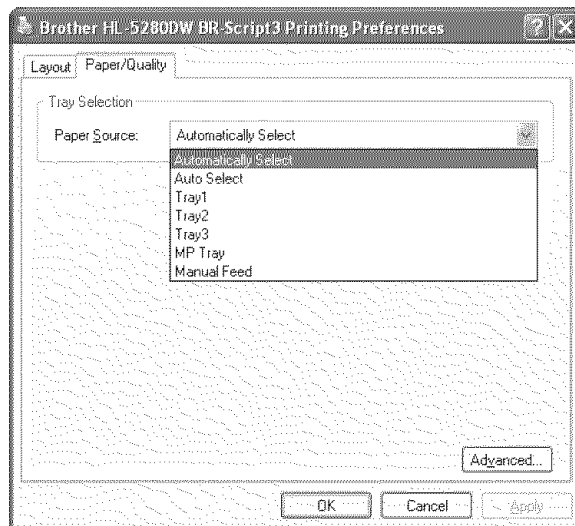

Advanced options

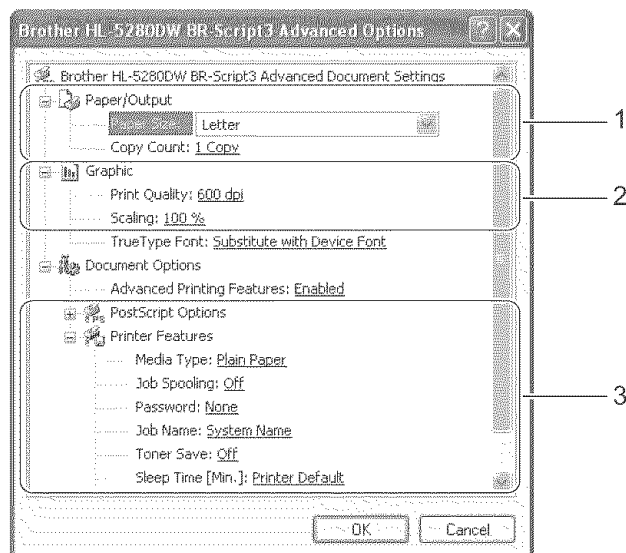

- ❶ Choose the **Paper Size** and **Copy Count** (1).
- ❷ Set the **Scaling** and **TrueType Font** settings (2).
- ❸ You can change settings by choosing the setting in the **Printer Features** list (3):
 - Print Quality
 - Media Type
 - Job Spooling
 - Passwprd
 - Job Name
 - Toner Save
 - You can save running costs by turning on the **Toner Save**, which reduces the print density.
 - Sleep Time
 - See *Device Options* on page 31.
 - Halftone Screen Lock
 - BR-Script Level

Features in the printer driver (For Macintosh®)

This printer supports Mac OS® 9.1 to 9.2 and Mac OS® X 10.2.4 or greater.

Note

The screens in this section are from Mac OS® X 10.4. The screens on your Macintosh® will vary depending on your operating system.

Page Setup

You can set the **Paper Size**, **Orientation** and **Scale**.

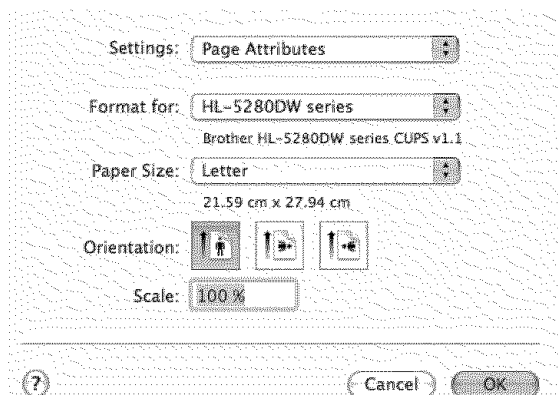

Layout

Set the **Pages per Sheet**, **Layout direction** and **Border**.

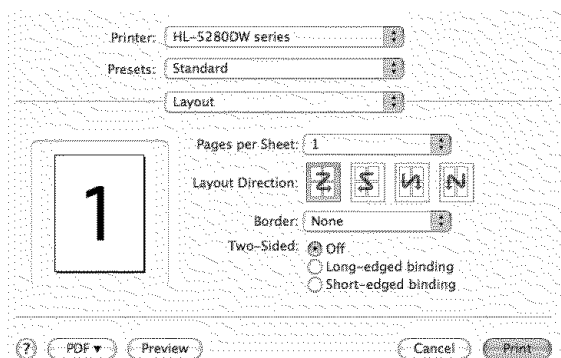

■ Pages per Sheet

Choose how many pages will appear on each side of the paper.

■ Layout Direction

When you specify the pages per sheet, you can also specify the direction of the layout.

■ Border

If you want to add a border, use this function.

Print Settings

You can change settings by choosing the setting in the **Print Settings** list:

Basic tab

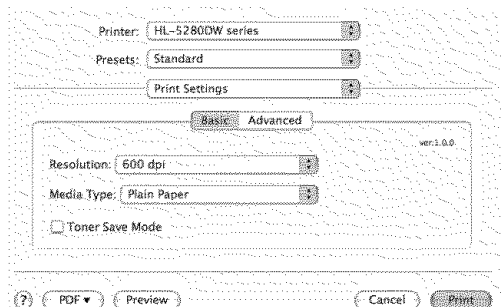

■ Resolution

You can change the resolution as follows:

- 300 dpi
- 600 dpi
- HQ 1200
- 1200 dpi



Note

If you use the high quality 1200 dpi setting (1200 × 1200 dpi) the print speed will be slower.

■ Media Type

You can change the media type as follows:

- Plain Paper
- Thin Paper
- Thick Paper
- Thicker Paper
- Bond Paper
- Transparencies
- Envelopes
- Env.Thick
- Env.Thin
- Recycled Paper

■ Toner Save Mode

You can save running costs by turning on Toner save, which reduces the print density.



Note

- We do not recommend Toner Save for printing Photo or Gray Scale images.
- **Toner Save Mode** is not available for **1200 dpi** or **HQ 1200** resolution.

Advanced tab

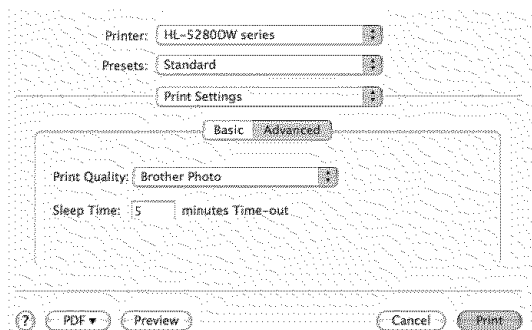

■ Print Quality

You can change the print quality as follows:

- Brother Photo

This is a photograph mode (gradation priority). Choose this setting for printing photographs that have continuous gradation. You can represent soft contrasts between various shades of gray.

- Brother Graphics

This is a graphics mode (contrast priority). Choose this setting for printing text and figures, such as business and presentation documents. You can represent sharp contrasts between shaded areas.

- Generic

This is a standard halftone pattern of Mac[®] OS X. If you choose this mode for printing text documents, the print speed will be faster. Use this mode for Mac[®]s that have less memory.

■ Sleep Time

When the printer does not receive data for a certain period of time, it enters sleep mode. In sleep mode, the printer acts as though it were turned off. The default setting for timeout is 5 minutes.

Intelligent Sleep Mode automatically adjusts to the most suitable timeout setting depending on the frequency of your printer use. While the printer is in sleep mode, the LCD light is off, but the printer can still receive data. Receiving a print file or document or pressing one of the buttons will automatically wake up the printer to start printing.

Status Monitor (For Mac[®] X 10.2.4 or greater users)

This reports the printer status (any errors that may happen with the printer) when printing. If you would like to turn the status monitor on, run the **BrStatusMonitor.app** (from the **Macintosh HD** (Startup Disk), choose **Library, Printers, Brother, Utilities**).

Uninstalling the printer driver

You can uninstall the printer driver that you installed with the following steps.



Note

- This is not available if you installed the printer driver from the Windows Add a printer function.
 - After uninstalling, we recommend that you restart your computer to remove files that were in use during the uninstall.
-

Printer driver for Windows®

For Windows® XP

- 1 Click the **Start** button, point to **All Programs** and then to your printer name.
- 2 Click **UnInstall**.
- 3 Follow the instructions on the screen.

For Windows® 95/98/Me/2000 and Windows NT® 4.0

- 1 Click the **Start** button, point to **Programs** and then to your printer name.
- 2 Click **UnInstall**.
- 3 Follow the instructions on the screen.

Brother Laser driver for Macintosh®

For Mac OS® X 10.2.4 or greater

- ① Disconnect the USB cable between the Macintosh and your printer.
- ② Restart the Macintosh®.
- ③ Log on as an 'Administrator'.
- ④ Run the **Printer Setup Utility**¹ (from the **Go** menu, choose **Applications, Utilities**), then choose the printer you want to remove and remove it by clicking the **Delete** button.
- ⑤ Drag the **HL-MFLPro** folder (from the **Macintosh HD** (Startup Disk), choose **Library, Printers, Brother**) into the Trash and then empty the Trash.
- ⑥ Restart the Macintosh®.

¹ **Print Center** for Mac OS® X 10.2 users

For Mac OS® 9.1 to 9.2

- ① Open the **Extensions** folder located in the **System Folder** on the **Macintosh HD**.
- ② Drag all these following files in the **Extensions** folder to the **trash**.
 - BR_PrintMonitor(laser)
 - Brother Laser
 - Brother Laser(IP)



Note

There may be several USB Print Driver(BRXXX)¹ and BR_PrintMonitor(BXX)¹ extensions with different endings.

¹ The 'x' refers to the model of your machine.

- ③ Restart the Macintosh®.
- ④ Once the computer has restarted you can then empty the trash.

Software

Software for networks

BRAdmin Professional (For Windows®)

The BRAdmin Professional is a utility for managing your Brother network enabled printers that are running under Windows® 95/98/Me/2000/XP and Windows NT® 4.0. It allows you to easily configure and check the status of your printer on the network.

BRAdmin Light (For Macintosh®)

The Brother BRAdmin Light software is a Java™ application that is designed for the Apple® Mac OS®X environment. It supports some of the features of the Windows® BRAdmin software. For example, using the BRAdmin Light software, you can change some network settings and update firmware on Brother's network ready printers and multifunction devices.

Driver Deployment Wizard (For Windows®)

This installer includes the Windows® printer driver and Brother network port driver (LPR and NetBIOS). If the administrator installs the printer driver and port driver using this application, the administrator can save the file to the file server or send the file by e-mail to users. Then, each user just clicks that file to have the printer driver, port driver, IP address, and so on, automatically copied to their PC.

Network Print Software (For Windows®)

This installer includes the port monitors (Peer-to-Peer Printing software). They allow you to print through the network (LAN) under Windows®

Web BRAdmin (For Windows®)

The Web BRAdmin is designed to manage all LAN/WAN Brother network connected devices. By installing the Web BRAdmin server utility on a PC running IIS¹, administrators with a web browser can connect to the Web BRAdmin server, which then communicates with the device itself. Unlike the BRAdmin Professional, which is designed for Windows® systems only, the Web BRAdmin server utility can be accessed from any client PC with a web browser that supports Java 2.

You can download the Web BRAdmin from our web site. Visit us at <http://solutions.brother.com>.

¹ Internet Information Server 4.0 or 5.0

Web BRAdmin and Internet Information Server 4.0 are supported by the following operating systems:

- Windows NT® 4.0 Server

Web BRAdmin and Internet Information Service 5.0 are supported by the following operating systems:

- Windows® 2000 Server
- Windows® 2000 Advanced Server
- Windows® 2000 Professional

Web BRAdmin and Internet Information Service 5.1 are supported by the following operating systems:

■ Windows® XP Professional

About emulation modes

This printer has the following emulation modes. You can change the setting by using the control panel or a Web browser.

■ HP LaserJet Mode

The HP LaserJet mode (or HP mode) is the emulation mode in which this printer supports the PCL6 language of the Hewlett-Packard® LaserJet laser printer. Many applications support this type of laser printer. Using this mode will allow your printer to run at its best with those applications.

■ BR-Script 3 Mode

BR-Script is an original Brother page description language and a PostScript® language emulation interpreter. This printer supports level 3. The BR-Script interpreter of this printer allows you to control text and graphics on pages.

For technical information about PostScript® commands, see the following manuals:

- Adobe Systems Incorporated. PostScript® Language Reference, 3rd edition. Addison-Wesley Professional, 1999. ISBN: 0-201-37922-8
- Adobe Systems Incorporated. PostScript® Language Program Design. Addison-Wesley Professional, 1988. ISBN: 0-201-14396-8
- Adobe Systems Incorporated. PostScript® Language Tutorial and Cookbook. Addison-Wesley Professional, 1985. ISBN: 0-201-10179-3

■ EPSON FX-850 and IBM Proprinter XL Mode

The EPSON FX-850 and IBM Proprinter XL modes are the emulation modes that this printer supports to meet the industry-standard for dot matrix printers. Some applications support these dot matrix printer emulations. Use these emulation modes so your printer will work well when printing from those types of applications.

Automatic emulation selection

This printer has an automatic emulation selection feature that is turned on by default. This lets it automatically change the emulation mode to suit the type of data it receives.

You can change the setting by using the control panel or a Web browser.

The printer can choose from the following combinations:

Setting 1 (default)	Setting 2
HP LaserJet	HP LaserJet
BR-Script 3	BR-Script 3
EPSON FX-850	IBM ProPrinter XL

Automatic interface selection

This printer has an automatic interface selection feature that is turned on by default. This lets it automatically change the interface to IEEE 1284 parallel, USB, or Ethernet depending on which interface is receiving data.

When you use the parallel interface, you can turn the high-speed and bi-directional parallel communications on or off by using the control panel buttons to access `PARALLEL` in the `INTERFACE` menu. (See *Menu table* on page 56.) Since the default setting is on for the automatic interface selection mode, simply connect the interface cable to the printer. Always turn off both your computer and printer when connecting or disconnecting the cable.



Note

This function takes a few seconds to work. If you want to speed up printing, choose the required interface manually by using the control panel to access `SELECT` in the `INTERFACE` menu.

If you typically use only one interface, we recommend that you choose that interface in the `INTERFACE` menu. If only one interface is chosen, the printer will allocate the entire input buffer to that interface.

4

Control Panel

Control panel

This printer has one liquid crystal display (LCD), seven buttons and one Light Emitting Diode (LED) on the control panel. The display can show various messages with up to 16 characters in one row. The LED light shows the current status of the printer.

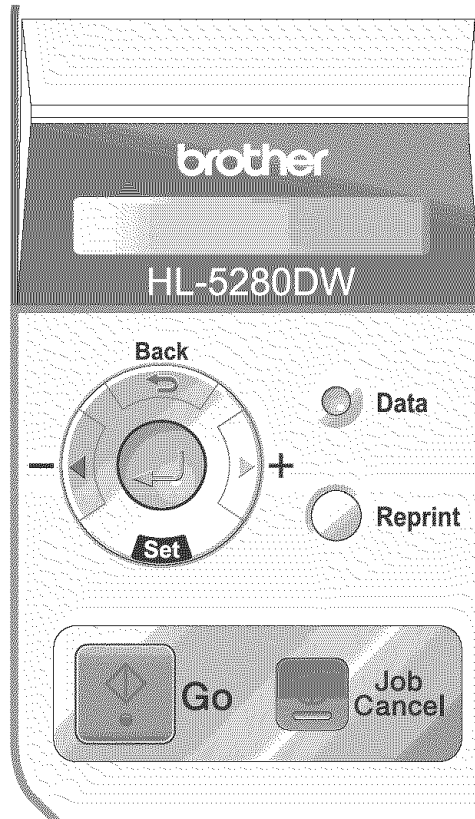

Buttons

You can control the basic printer operations and change various printer settings with seven buttons (**Go**, **Job Cancel**, **Reprint**, **+**, **-**, **Back**, **Set**).

button	Operations
Go	Exit from the control panel menu and reprint settings. Clear error messages. Pause and continue printing.
Job Cancel	Stop and cancel the printing job in progress.
Reprint	Choose the reprint menu and the number of extra copies (1-999).
+	Move forward through menus. Move forward through the available options.
-	Move backward through menus. Move backward through the available options.
Back	Go back one level in the menu structure.
Set	Choose the control panel menu. Set the chosen menus and settings.

Go

Pressing **Go** will exit the control panel menu and return the printer to the Ready state, however, if there is an ERROR indication, the control panel will only change when the error is cleared.

You can pause printing by pressing **Go**. Pressing **Go** again restarts the print job. During a pause, the printer is offline.



Note

If the printer is in PAUSE mode and you do not want to print the data left, press **Job Cancel**. Once the job has been cancelled, the printer will return to the READY state.

Job Cancel

You can cancel the processing or printing of data by pressing **Job Cancel**. The LCD shows JOB CANCELLING until the job is cancelled. After cancelling the job, the printer returns to the READY state.

When the printer is not receiving data or printing, the LCD shows No Data!!! and you cannot cancel the job.

If you press **Job Cancel** on the menu, the reprint data will be deleted and the printer will go online.

Reprint

If you want to reprint a document that has just been printed, press **Reprint**.

You can reprint when the printer is in the READY or PAUSE state.

For details, see *Reprinting documents* on page 52.

+ or - button

Moving through menus on the LCD

Pressing the + or - button when the printer is in the Ready state, takes it offline and the LCD will show the control panel menu.

Press to scroll through the menus and options. Press or keep pressing the button until you see the setting you want.

Entering numbers

You can enter numbers in two ways. You can press the + or - button to move up or down one number at a time, or you can hold down the + or - button to move faster. When you see the number you want, press **Set**.

Back

If you press **Back** when the printer is online (READY), it goes offline and the LCD returns to the menu.

Pressing **Back** allows you to return to the previous level from the current menu level.

Back also allows you to choose the previous digit while setting numbers.

When you choose a setting and it does not have an asterisk (**Set** was not pressed), **Back** allows you to return to the previous menu level with the original setting unchanged.



Note

When you press **Set** to choose a setting, an asterisk appears briefly at the end of the display. Since the asterisk shows what you have chosen, you can easily see the current settings as you look through the LCD.

Set

Pressing **Set** when the printer is in the Ready state takes it offline, and the LCD will show the control panel menu.

Pressing **Set** allows you to choose the displayed menu or option. After changing a setting, an asterisk (*) appears briefly on the right-hand side of the message.

Data LED

The Data LED is a light which shows the printer status.

LED indication	Meaning
On	Data is in the printer memory.
Blinking	Receiving or processing data.
Off	No remaining data in the memory.

LCD

The LCD shows the current printer status. When you use the control panel buttons, the LCD will change.

If there are any problems, the LCD shows the proper error message, maintenance message or call service message so you will know that you need to take action. For more information about these messages, see *LCD messages* on page 92.

Back light

Light	Meaning
Off	The printer is off or in sleep status.
Green (General)	Ready to print Printing Warming up Job cancelling
Red (Error)	There is a problem with the printer.
Orange (Setting)	The printer is offline. Choosing a menu Setting number of reprints Pause

LCD messages

Printer status messages

The following table shows the printer status messages during normal operation:

Printer Status Message	Meaning
IGNORE DATA	Printer is ignoring data processed using PS driver.
JOB CANCELLING	Cancelling the job.
Now Initializing	The printer is setting up.
PAUSE	The printer has suspended its operations. Press Go to start the printer again.
PRESS SET TO PRINT	Press Set to start printing.
PRINTING	Printing.
PROCESSING	Busy processing data.
RAM SIZE=XX MB	This printer has XX MB memory.
READY	Ready to print.
RESET TO FACTORY SETTINGS	The printer settings return to the default settings.
RESET TO USER SETTINGS	The printer settings return to the user settings.
RESOLUTION ADAPT	Printing with reduced resolution.
SELF TEST	Performing self-diagnostics.
SLEEP	In Sleep state.
WARMING UP	The printer is warming up.
COOLING DOWN	The printer is cooling down.

Reprinting documents

Reprinting from RAM

You can reprint from random access memory (RAM). The reprint data in RAM will be deleted when the printer is turned off.

When you use RAM to reprint:

- ① Press **Set** on the control panel.
- ② Press the **+** or **-** button to choose `SETUP`. Press **Set**.
- ③ Press the **+** or **-** button to choose `RAMDISK SIZE`. Press **Set**.
- ④ The present RAM disk is 0MB. Press the **+** button to increase the reprint RAM size in increments of 1MB.
- ⑤ Press **Set**.



Note

When you increase the RAM size for secure printing, the work area of the printer is decreased and the printer performance will be reduced. Make sure that you reset the RAM disk size to 0MB after you finish using secure printing.

We recommend that you add more RAM if you want to be able to print a lot of secure data. (See *Installing extra memory* on page 71).

Reprinting the last job

You can reprint the data from the last print job without sending it from the computer again.



Note

- If the `REPRINT` setting is set to `OFF` on the control panel and you press **Reprint**, the LCD shows `NO DATA STORED` for a short time.
 - If you want to cancel reprinting, press **Job Cancel**.
 - If the printer does not have enough memory to spool the print job data, it will only print the last page.
 - Pressing the **-** or **+** button makes the number of reprint copies decrease or increase. You can choose between 1 and 999 `COPIES`.
 - For more information about the settings in the printer driver, see *Device Options* on page 31.
-

Reprinting the last job three times

- 1 Make sure that the **REPRINT** setting is **ON** by using the control panel buttons to enter the **SETUP** menu.



Note

If you print with the driver we have supplied with the printer, the settings for **Job Spooling** in the printer driver will take priority over the settings made on the control panel. For more information, see *Device Options* on page 31.

- 2 Press **Reprint**.
If you wait too long to continue the control panel button operation, the printer leaves the **REPRINT** setting automatically.

COPIES=1

- 3 Press the **+** button twice.

COPIES=3

- 4 Press **Set** or **Reprint**.

PRINTING



COPIES=1



Note

- If you press **Go** twice, the printer will leave the **REPRINT** setting.
- If you want to reprint the data and have pressed **Go**, the LCD shows **PRESS SET TO PRINT**. Press **Set** or **Reprint** to start reprinting, or press **Go** again to cancel the reprint job.

Printing Secure data

■ Secure data

Secure documents are protected by a password and only those people who know the password will be able to print the document. The printer will not print the document when you send it for printing. To print the document, you must use the control panel of the printer (with the password) or connect to the printer using a web browser. Secure data will be deleted after printing once.

When the area to spool data is full, the earliest data is automatically deleted first. The order of deleting data is not connected to the order of reprinting.

If you want to delete the spooled data, you can carry out this operation using the control panel or the web-based management application.



Note

- The reprint data will be deleted when the printer is turned off.
- For more information about the settings in the printer driver, see *Device Options* on page 31.

How to print Secure data

- 1 Press **Reprint**. If there is no data, the LCD shows NO DATA STORED.

LAST JOB

- 2 Press the + or - button to choose SECURE FILE. Press **Set**.

SECURE FILE

- 3 Press the + or - button to choose the user name. Press **Set**.

XXXXXX

- 4 Press the + or - button to choose the job. Press **Set**.

XXXXXX

- 5 Enter your password. Press **Set**.

PASS NO.=0000



Note

The printer will exit this menu after a time-out period.

- 6 Press **Set** or **Reprint**.
If you press **Go**, the LCD shows PRESS SET TO PRINT.

COPIES=1



PRINTING

Cancelling the reprint job

If you want to cancel the current reprint job, press **Job Cancel**. **Job Cancel** also allows you to cancel a paused reprint job.

Using the control panel LCD menu

When you use the Menu buttons (+, -, **Set** or **Back**), remember the following basic steps:

- If no control panel operations are performed for 30 seconds, the LCD automatically returns to **READY**.
- When you press **Set** to choose a setting, an asterisk appears at the end of the LCD for a short time. After that, the LCD returns to the previous menu level.
- After changing the status or a setting, pressing **Back** before you press **Set** will cause the LCD to return to the previous menu level with the original settings unchanged.
- There are two ways to input numbers. You can press the + or - button to scroll up or down one number at a time, or you can hold down the + or - button to scroll faster. The blinking number is the one that you can change.

For example: If you feed paper from the MP tray as a priority, change the MP FIRST setting to ON as follows.

The default setting is **OFF**. Turn this setting **ON** if you want to.

- 1 Press any of the **Menu** buttons (+, -, **Set** or **Back**) to take the printer offline.

READY



INFORMATION

- 2 Press the + or - button to choose **PAPER**.

PAPER

- 3 Press **Set** to move to the next menu level.

SOURCE

- 4 Press the + or - button to choose **MP FIRST**.

MP FIRST

- 5 Press **Set**.

=OFF *

- 6 Press the + button to choose **ON**.

=ON

- 7 Press **Set**.
An asterisk * briefly appears at the end of the LCD.
The current setting is shown by an *.

=ON *

Menu table

There are eight menus. For more information about the selections available in each menu, see the tables below.



Note

The control panel LCD names for the paper trays are as follows.

- Standard paper tray: TRAY1
- Multi-purpose tray: MP
- Optional lower tray: TRAY2 or TRAY3

INFORMATION

Submenu	Menu Selections	Descriptions
PRINT SETTINGS		Prints the Printer Settings page.
PRINT TEST		Prints the test page.
PRINT DEMO		Prints the demonstration sheet.
PRINT FILE LIST		Prints the list of data saved in the embedded memory.
PRINT FONTS		Prints the font list and samples.
VERSION	SER.NO=#####	Shows printer serial number.
	ROM VER=####	Shows main firmware version.
	ROM DATE=##/##/##	Shows main firmware date.
	NET VER=####	Shows network firmware version.
	NET DATE=##/##/##	Shows network firmware date.
	RAM SIZE=###MB	Shows the size of memory in this printer.
MAINTENANCE	PAGE COUNTER	Shows the current total printed pages.
	DRUM COUNT	Shows the pages printed with drum unit.
	REMAIN DRUM	Shows the pages left to print with drum unit.
	REMAIN PF KIT MP	Shows the pages left to print with PF kit MP. See <i>Replacing periodic maintenance parts</i> on page 84.
	REMAIN PF KIT 1	Shows the pages left to print with PF kit 1. See <i>Replacing periodic maintenance parts</i> on page 84.
	REMAIN PF KIT 2	Shows the pages left to print with PF kit 2. See <i>Replacing periodic maintenance parts</i> on page 84.
	REMAIN PF KIT 3	Shows the pages left to print with PF kit 3. See <i>Replacing periodic maintenance parts</i> on page 84.
	REMAIN FUSER	Shows the pages left to print with fuser unit.
	REMAIN LASER	Shows the pages left to print with laser unit.

PAPER

Submenu	Options	Descriptions
SOURCE	AUTO* /MP/TRAY1/TRAY2/TRAY3	Chooses the tray that will be used.
PRIORITY	MP>T1>T2>T3* /T1>T2>T3>MP/ T1>T2>T3	When SOURCE is chosen as AUTO: Chooses the order in which the printer uses the paper trays that contain paper of the same size.
MP FIRST	ON/ OFF*	Chooses whether to feed paper from the MP tray as a priority.
MP SIZE	ANY* /LETTER/LEGAL/A4...	Chooses the size of paper you put in the MP tray.
MP MEDIA FIX	OFF* /PLAIN PAPER/THIN PAPER...	Chooses the media type of paper you put in the MP tray. When you choose the media type here (except OFF), the setting for Media Type selected in the printer driver will be ignored.
MANUAL FEED	OFF* /ON	Chooses whether you want to feed paper manually.
TRAY1 SIZE	ANY* /LETTER/LEGAL/A4...	Chooses the size of paper you loaded in the standard paper tray.
TRAY2 SIZE	ANY* /LETTER/LEGAL/A4...	Chooses the size of paper you loaded in the optional lower tray.
TRAY3 SIZE	ANY* /LETTER/LEGAL/A4...	Chooses the size of paper you loaded in the optional lower tray.
DUPLEX	OFF* /ON (LONG BIND)/ON (SHORT BIND)	Chooses whether you want to automatically print on both sides of the paper.
 The default settings are shown in Bold with an asterisk.		

QUALITY

Submenu	Options	Descriptions
RESOLUTION	300/ 600* /HQ1200/1200	Chooses a print resolution 300, 600 or 1200 dots per inch or HQ1200 (2400x600 dpi).
TONER SAVE	OFF* /ON	
DENSITY	-6/-5/-4/-3/-2/-1/ 0* /1/2/3/4/5/6	Increases or decreases the print density.
 The default settings are shown in Bold with an asterisk.		

SETUP

Submenu	Menu Selections	Options	Descriptions
LANGUAGE		ENGLISH* /FRANÇAIS...	Changes the LCD language for your country.
 The default settings are shown in Bold with an asterisk.			

SETUP (Continued)

Submenu	Menu Selections	Options	Descriptions
PANEL CONTROL	LCD DENSITY	0 */1	Adjusts the density of the LCD.
	AUTO ONLINE	ON */OFF	
	BUTTON REPEAT	0.1 */0.2/0.3/0.4/0.5/1.0 /1.5/2.0 SEC	Sets the time for the LCD message to change when holding the + or - button at intervals.
	MESSAGE SCROLL	LEVEL 1 */LEVEL 2.../LEVEL10	Sets the time in seconds that an LCD message will scroll across the LCD. From Level 1=0.2 to Level 10=2.0.
POWER SAVE TIME		1/2/3/4/ 5 *.../ 240 MIN	Sets the time to return to Power Save mode.
AUTO CONTINUE		OFF */ON	
LOCK PANEL	PASS NO. =###	OFF */ON	Turns the lock panel settings ON or OFF.
REPRINT		ON */OFF	
PAGE PROTECTION		AUTO */OFF/LETTER/A4/LEGAL	
EMULATION		AUTO (EPSON) */AUTO (IBM)/HP LASER JET/...	
KEEP PCL		OFF */ON	
RAMDISK SIZE		0 */1/2... MB	
DELETE STORAGE	SECURE FILE		Deletes the data in ROM.
	DATA ID (ROM)		
	MACRO ID (ROM)		
	FONT ID (ROM)		
	FORMAT (ROM)		Formats the ROM.
 The default settings are shown in Bold with an asterisk.			

PRINT MENU

Submenu	Menu Selections	Options	Descriptions
MEDIA TYPE		PLAIN PAPER */THIN PAPER/THICK PAPER/THICKER PAPER/BOND PAPER/TRANSPARENCIES/ENVELOPES/ENV. THIN/ENV. THICK/RECYCLED PAPER	Sets the type of paper.
 The default settings are shown in Bold with an asterisk.			

PRINT MENU (Continued)

Submenu	Menu Selections	Options	Descriptions
PAPER		LETTER* /LEGAL/ A4* /EXECUTIVE/COM-10/DL/JIS B5/B5/A5/B6/A6/MONARCH/C5/A4 LONG/FOLIO/DLL/POST CARD/ORGANIZER J/ORGANIZER K/ORGANIZER M/ORGANIZER L	Sets the size of paper.
COPIES		1* /2.../999	Sets the number of printed pages.
ORIENTATION		PORTRAIT* /LANDSCAPE	This printer can print pages in portrait or landscape orientation.
PRINT POSITION	X OFFSET	-500/-499.../0*.../+499/+500	Moves the print start position (at the top-left corner of pages) horizontally up to -500 (left) to +500 (right) dots in 300 dpi.
	Y OFFSET	-500/-499.../0*.../+499/+500	Moves the print start position (at the top-left corner of pages) vertically up to -500 (up) to +500 (down) dots in 300 dpi.
AUTO FF TIME		OFF* /1/2/3.../99 (sec)	Allows you to print the remaining data without pressing Go .
FF SUPPRESS		OFF* /ON	Turns the feed suppress (PAUSE) setting ON or OFF.
 The default settings are shown in Bold with an asterisk.			

PRINT MENU (Continued)

Submenu	Menu Selections	Options	Descriptions
HP LASERJET	FONT NO.	I000...#### (59)*	
	FONT PITCH/POINT	##.## (10.00/12.00)*	
	SYMBOL SET	PC-8*...	Sets the symbol set or the character set.
	TABLE PRINT		Prints code table.
	AUTO LF	OFF*/ON	ON: CR → CR+LF, OFF: CR → CR
	AUTO CR	OFF*/ON	ON: LF→LF+CR, FF→FF+CR, or VT → VT+CR OFF: LF → LF, FF → FF, or VT → VT
	AUTO WRAP	OFF*/ON	Chooses whether a line feed and carriage return will happen when the printer reaches the right margin.
	AUTO SKIP	OFF*/ON	Chooses whether a line feed and carriage return will happen when the printer position reaches the bottom margin.
	LEFT MARGIN	####	Sets the left margin at column 0 to 70 columns at 10 cpi.
	RIGHT MARGIN	####	Sets the right margin at column 10 to 80 columns at 10 cpi.
	TOP MARGIN	####	Sets the top margin at a distance from the top edge of the paper: 0, 0.33, 0.5, 1.0, 1.5 or 2.0. The default setting is 0.5.
	BOTTOM MARGIN	####	Sets the bottom margin at a distance from the bottom edge of the paper - 0, 0.33, 0.5, 1.0, 1.5 or 2.0. The default setting is 0.33(None-HP), 0.5(HP).
	LINES	####	Sets the number of lines on each page from 5 to 128 lines.



The default settings are shown in Bold with an asterisk.

PRINT MENU (Continued)

Submenu	Menu Selections	Options	Descriptions
EPSON FX-850	FONT NO.	I000...#### (59)*	
	FONT PITCH/POINT	##.## (10.00/12.00)*	
	CHARACTER SET	PC-8... (US ASCII)*	Sets the symbol set or the character set.
	TABLE PRINT		Prints code table.
	AUTO LF	OFF*/ON	ON: CR → CR+LF OFF: CR → CR
	AUTO MASK	OFF*/ON	
	LEFT MARGIN	####	Sets the left margin at column 0 to 70 columns at 10 cpi.
	RIGHT MARGIN	####	Sets the right margin at column 10 to 80 columns at 10 cpi.
	TOP MARGIN	####	Sets the top margin at a distance from the top edge of the paper - 0, 0.33, 0.5, 1.0, 1.5 or 2.0. The default setting is 0.33.
	BOTTOM MARGIN	####	Sets the bottom margin at a distance from the bottom edge of the paper - 0, 0.33, 0.5, 1.0, 1.5 or 2.0. The default setting is 0.33.
LINES	####	Sets the number of lines on each page from 5 to 128 lines.	

 The default settings are shown in Bold with an asterisk.

PRINT MENU (Continued)

Submenu	Menu Selections	Options	Descriptions
IBM PROPRINTER	FONT NO.	I000...####(59)*	
	FONT PITCH	##.##(10.00/12.00)*	
	CHARACTER SET	PC-8...*	Sets the symbol set or the character set.
	TABLE PRINT		Prints code table.
	AUTO LF	OFF*/ON	ON: CR → CR+LF, OFF: CR → CR
	AUTO CR	OFF*/ON	ON: LF→LF+CR, FF→FF+CR, or VT → VT+CR OFF: LF → LF, FF → FF, or VT → VT
	AUTO MASK	OFF*/ON	
	LEFT MARGIN	####	Sets the left margin at column 0 to 70 columns at 10 cpi.
	RIGHT MARGIN	####	Sets the right margin at column 10 to 80 columns at 10 cpi.
	TOP MARGIN	####	Sets the top margin at a distance from the top edge of the paper - 0, 0.33, 0.5, 1.0, 1.5 or 2.0. The default setting is 0.33.
	BOTTOM MARGIN	####	Sets the bottom margin at a distance from the bottom edge of the paper - 0, 0.33, 0.5, 1.0, 1.5 or 2.0. The default setting is 0.33.
LINES	####	Sets the number of lines on each page from 5 to 128 lines.	
BR-SCRIPT3	ERROR PRINT	ON*/OFF	
CARBON MENU	CARBON COPY	OFF*/ON/AUTO/PARALLEL	
	COPIES	1.../8	
	COPY 1 TRAY	AUTO/REMAINING/MP TRAY/TRAY1/TRAY2/TRAY3	
	COPY 1 MACRO	(ID number)	
	COPY 2 TRAY... COPY 8 TRAY	AUTO/REMAINING/MP TRAY1/TRAY2/TRAY3	Appears when printing 2 pages or more.
	COPY 2 MACRO... COPY 8 MACRO	(ID number)	Appears when printing 2 pages or more.
 The default settings are shown in Bold with an asterisk.			

NETWORK for HL-5270DN users

Submenu	Menu Selections	Options	Descriptions
TCP/IP	TCP/IP ENABLE	ON* /OFF	
	IP ADDRESS=	###.###.###.### (000.000.000.000)* ¹	Enter the IP address.
	SUBNET MASK=	###.###.###.### (000.000.000.000)* ¹	Enter the Subnet mask.
	GATEWAY=	###.###.###.### (000.000.000.000)*	Enter the Gateway address.
	IP BOOT TRIES	# (3)	
	IP METHOD	AUTO* /STATIC/RARP/BOOTP /DHCP	Chooses the IP method that best suits your needs.
	APIPA	ON* /OFF	Automatically allocates the IP address from the link-local address range. ¹
	IPV6	ON/ OFF*	
NETBIOS/IP		ON* /OFF	
ENET		AUTO* /100B-FD/100B-HD/ 10B-FD/10B-HD	Chooses Ethernet link mode.
FACTORY RESET	Restores all network settings of the internal print server to default.		
 The default settings are shown in Bold with an asterisk.			

¹ On connection to the network, if the machine's 'IP METHOD' is 'AUTO' the machine will attempt to automatically set the IP address and Subnet Mask from a boot server such as DHCP or BOOTP. If a boot server cannot be found an APIPA IP address will be allocated, such as 169.254.[001-254].[000-255]. If the 'IP METHOD' of the machine is set to 'STATIC' you will need to manually enter an IP address from the machine's control panel.

NETWORK for HL-5280DW users

Submenu 1	Submenu 2	Menu Selections	Options	Descriptions
WIRED	WIRED ENABLE		ON*/OFF	
	TCP/IP	TCP/IP ENABLE	ON*/OFF	
		IP ADDRESS=	###.###.###.### (000.000.000.000)* ¹	Enter the IP address.
		SUBNET MASK=	###.###.###.### (000.000.000.000)* ¹	Enter the Subnet mask.
		GATEWAY=	###.###.###.### (000.000.000.000)*	Enter the Gateway address.
		IP BOOT TRIES	# (3)	
		IP METHOD	AUTO*/STATIC/RARP/BOOTP/DHCP	Chooses the IP method that best suits your needs.
		APIPA	ON*/OFF	Automatically allocates the IP address from the link-local address range. ¹
	IPV6	ON/ OFF*		
	ENET		AUTO*/100B-FD/100B-HD/10B-FD/10B-HD	Chooses Ethernet link mode.
NETBIOS/IP		ON*/OFF		
SET DEFAULT	Restores wired network settings of the internal print server to default.			
WLAN	WLAN ENABLE		ON*/OFF	
	TCP/IP	TCP/IP ENABLE	ON*/OFF	
		IP ADDRESS=	###.###.###.### (000.000.000.000)* ¹	Enter the IP address.
		SUBNET MASK=	###.###.###.### (000.000.000.000)* ¹	Enter the Subnet mask.
		GATEWAY=	###.###.###.### (000.000.000.000)*	Enter the Gateway address.
		IP BOOT TRIES	# (3)	
		IP METHOD	AUTO*/STATIC/RARP/BOOTP/DHCP	Chooses the IP method that best suits your needs.
		APIPA	ON*/OFF	Automatically allocates the IP address from the link-local address range. ¹
	IPV6	ON/ OFF*		
	WIRELESS	SECUREEASYSETUP	YES*/EXIT	



The default settings are shown in Bold with an asterisk.

NETWORK for HL-5280DW users (Continued)

Submenu 1	Submenu 2	Menu Selections	Options	Descriptions
WLAN (Continued)	WIRELESS (Continued)	COMM.MODE	AD-HOC* /INFRASTRUCTURE	Shows the current Communication Mode.
		LIST SSID	(Shows a list of available names for the wireless network)	
		SSID	(Shows SSID [uses a maximum of 32 digits and characters 0-9, a-z and A-Z in ASCII values])	
		CHANNEL	1 11* . . 14	Chooses the channel you use.
		AUTHENTICATION	OPEN SYSTEM* /SHARED KEY/WPA-PSK/LEAP	Chooses the authentication methods.
		ENCRYPTION	NONE* /WEP/TKIP/AES/CK IP	Chooses the encryption methods.
		WEP KEY SELECT	KEY1* /KEY2/KEY3/KEY4	Chooses the WEP key you use.
		WEP KEY1 SIZE	128 (104) BITS* /64 (40) B ITS	Sets the size of WEP key1.
		WEP KEY1 TYPE	ASCII* /HEX	Chooses the input type of WEP key1.
		WEP KEY1	(Shows the WEP key [uses a maximum of 5 or 13 digits and characters 0-9, a-z and A-Z in ASCII values, or uses a maximum of 10 or 26 digits and characters 0-9 and A-F in HEX values])	
		WEP KEY2 SIZE		
		WEP KEY2 TYPE		
		WEP KEY2		
		WEP KEY3 SIZE		
		WEP KEY3 TYPE		
		WEP KEY3		
		WEP KEY4 SIZE		
		WEP KEY4 TYPE		
		WEP KEY4		
		PASSPHRASE		
		USER		
PASSWORD				
APPLY	YES* /YES&REPORT	Applies the wireless settings.		
NETBIOS/IP		ON* /OFF		
SET DEFAULT	Restores wireless network settings of the internal print server to default.			
FACTORY RESET	Restores all network settings of the internal print server to default.			



The default settings are shown in Bold with an asterisk.

¹ On connection to the network, if the machine's 'IP METHOD' is 'AUTO' the machine will attempt to automatically set the IP address and Subnet Mask from a boot server such as DHCP or BOOTP. If a boot server cannot be found an APIPA IP address will be allocated, such as 169.254.[001-254].[000-255]. If the 'IP METHOD' of the machine is set to 'STATIC' you will need to manually enter an IP address from the machine's control panel.

INTERFACE

Submenu	Menu Selections	Options	Description
SELECT		AUTO* /PARALLEL/USB/NETW ORK	
AUTO IF TIME		1/2/3/4/5*.../99 (sec)	You need to set the time-out period for the auto interface selection.
INPUT BUFFER		Level 1/2/3*.../15	Increases or decreases the input buffer capacity.
PARALLEL	HIGH SPEED	ON* /OFF	Turns high-speed parallel communications ON or OFF.
	BI-DIR	ON* /OFF	Turns bi-directional parallel communications ON or OFF.
	INPUT PRIME	ON/ OFF*	Turns prime signal ON or OFF.
USB 2.0	HIGH SPEED	ON* /OFF	Turns High-Speed USB 2.0 communications ON or OFF.
 The default settings are shown in Bold with an asterisk.			

RESET MENU

Display Shows	Description
RESET PRINTER	Resets the printer and restores all printer settings (including command settings) to settings you have previously made with the control panel buttons.
FACTORY RESET	Resets the printer and restores all printer settings (including command settings) to the default settings.

Example of changing the menu setting

Setting IP Address

- 1 Press the + or - button to choose NETWORK (and to display each setting shown below).

INFORMATION



NETWORK

- 2 Press **Set**.

TCP/IP

- 3 Press **Set**.

TCP/IP ENABLE

- 4 Press the + button.

IP ADDRESS=

- 5 Press **Set**.

The last digit in the first part of the number is blinking.

192. 0. 0. 192*

- 6 Press the + or - button to increase or decrease the number.
Press **Set** to go to the next number.

123. 0. 0. 192*

- 7 Repeat this process until you have set your IP address.

123. 45. 67. 89

- 8 Press **Set** to finish the IP address.
An asterisk appears at the end of the LCD.

123. 45. 67. 89*

Default Settings

Printer default setting

The printer settings have been set at the factory before shipment. They are called default settings (see *Menu table* on page 56). Although you can run the printer with these default settings unchanged, you can tailor the printer with user settings.



Note

Changing the user settings does not affect the default settings. You cannot modify the present default settings.

The changed user settings can be restored to the default settings with the `RESET MENU`. See *Menu table* on page 56.



Note

- The emulation mode affects the setting.
- The following settings cannot be restored to the default settings with `FACTORY RESET` in the `RESET MENU`: `INTERFACE`, `PAGE PROTECTION`, `SCALABLE FONT`, `LOCK PANEL`, page counter and local language for display messages.
- The `COPY` setting is always restored to the default setting when the printer is turned off and on again.

Network default setting

If you want to reset the print server back to its default settings (resetting all information such as the password and IP address information), follow these steps:

- 1 Press the `+` or `-` button to choose `NETWORK`. Press **Set**.

`NETWORK`

- 2 Press the `+` or `-` button to choose `FACTORY RESET`. Press **Set**.

`FACTORY RESET`

- 3 Press **Set** again.

`OK?`

5

Options

This printer has the following optional accessories. You can increase the capabilities of the printer with these items.

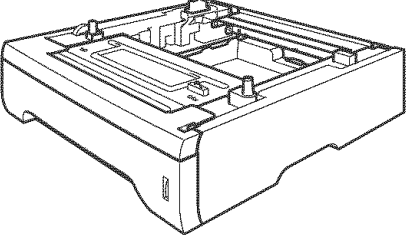
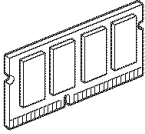
Lower tray unit	DIMM memory
LT-5300	
	
See <i>Lower tray unit (LT-5300)</i> on this page.	See <i>DIMM</i> on page 70.

Lower tray unit (LT-5300)

Two optional lower trays (Tray 2 or Tray 3) can be installed, and each lower tray can hold up to 250 sheets of 80 g/m² (21 lb) paper. When both optional trays are installed, the printer can hold up to 800 sheets of plain paper. If you want to buy an optional lower tray unit, call the dealer you bought the printer from.

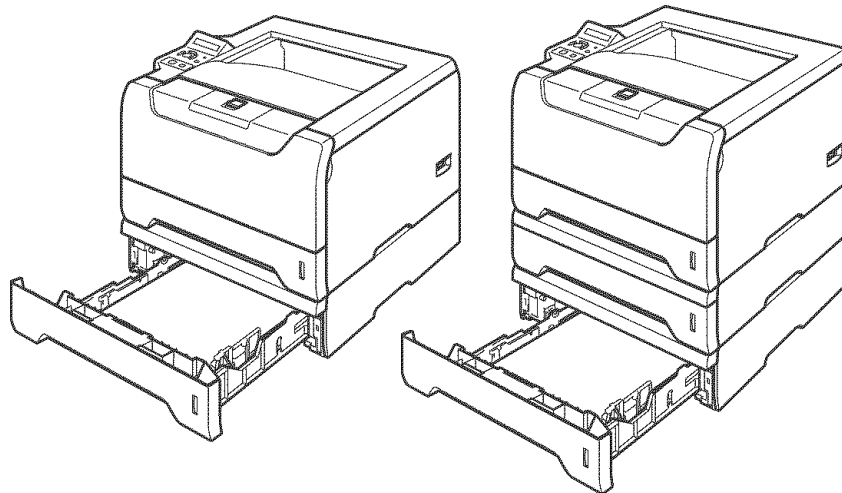

For setup, see the User's Guide that we have supplied with the lower tray unit.

DIMM

The printer has 32 MB of standard memory and one slot for optional memory expansion. You can expand the memory up to 544 MB by installing dual in-line memory modules (DIMMs).

DIMM types

You can install the following DIMMs:

- 128 MB Buffalo Technology VN133-D128 / VN133-X128
- 256 MB Buffalo Technology VN133-D256
- 512 MB Buffalo Technology VN133-D512
- 64 MB TechWorks 12165-0004
- 128 MB TechWorks 12462-0001
- 256 MB TechWorks 12485-0001
- 512 MB TechWorks 12475-0001



Note

- For more information, visit the Buffalo Technology site at <http://www.buffalotech.com>.
 - For more information, visit the Techworks web site at <http://www.techworks.com>.
-

In general, the DIMM must have the following specifications:

Type: 144 pin and 64 bit output

CAS latency: 2

Clock frequency: 100 MHz or more

Capacity: 64, 128, 256 or 512 MB

Height: 31.75 mm (1.25 in.)

Dram Type: SDRAM 2 Bank

SDRAM can be used.



Note

- There might be some DIMMs that will not work with the printer.
 - For more information, call the dealer you bought the printer from or Brother Customer Service.
-

Installing extra memory

- 1 Turn off the printer power switch, and then unplug the printer. Disconnect the interface cable from the printer.

**Note**

Be sure to turn off the printer power switch before you install or remove the DIMM.

- 2 Remove the DIMM cover.

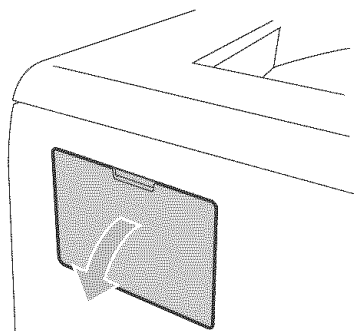

- 3 Unpack the DIMM and hold it by its edges.

**CAUTION**

To prevent damage to the printer from static electricity, DO NOT touch the memory chips or the board surface.

- 4 Hold the DIMM by the edges and align the notches in the DIMM with the protrusions in the slot. Insert the DIMM diagonally (1), then tilt it toward the interface board until it click into place (2).

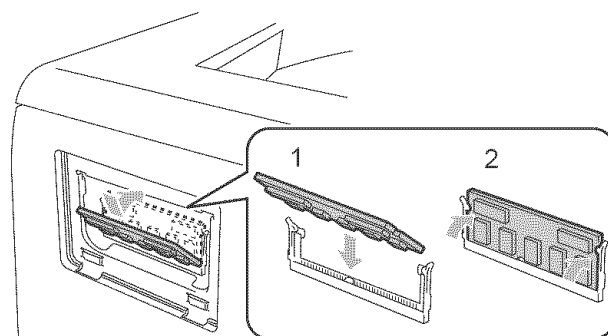

- 5 Put the DIMM cover back on.

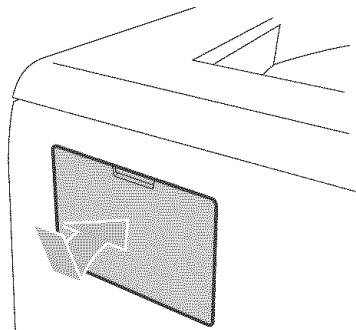

- 6 Reconnect the interface cable to your printer. Plug the printer back in, and then turn on the power switch.

**Note**

To make sure that you have installed the DIMM properly, you can print the printer settings page that shows the current memory size. See *Menu table* on page 56.

6

Routine Maintenance

You will need to replace certain parts and clean the printer regularly.

WARNING

When you replace certain parts or clean the inside of the printer, remember the following:

- If your clothes are smeared with toner, wipe off the toner with a dry cloth and immediately wash the clothes in cold water to avoid stains.
- Be careful not to inhale toner.
- After you have just used the printer, some internal parts of the printer will be extremely hot. When you open the front cover or back cover of the printer, DO NOT touch the shaded parts shown in the illustration.

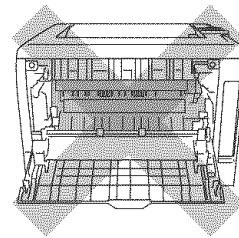
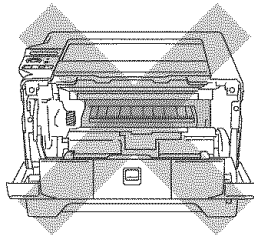

Replacing the consumable items

You will need to replace the consumable items regularly. When the time comes to replace consumable items, the following messages will appear on the LCD.

TONER LOW

(Appears at intervals.) See *TONER LOW Message* on page 74.

TONER LIFE END

See *TONER LIFE END message* on page 74.

DRUM NEAR END

See *DRUM NEAR END message* on page 80.



Note

These instructions are also included in *Improving the print quality* on page 105.

Consumables

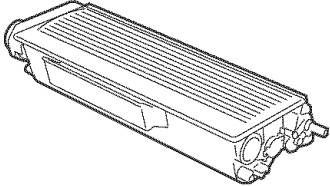
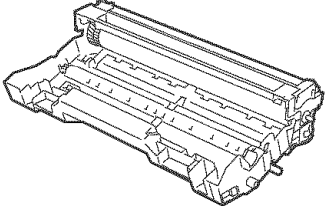
Toner Cartridge	Drum Unit
	
See <i>Toner cartridge</i> on page 74.	See <i>Drum unit</i> on page 80.

Toner cartridge

A new toner cartridge can print approximately 3,500 (standard cartridge) or approximately 7,000 (high yield cartridge) A4 or Letter size single-sided pages at 5% coverage.

Note

- The amount of toner used varies according to what is printed on the page and the print density setting.
- If you change the print density setting for lighter or darker printing, the amount of toner used will change.
- Wait to unpack the toner cartridge until immediately before you put it into the printer.

TONER LOW Message

(Appears at intervals.)

TONER LOW

If the LCD shows **TONER LOW**, the printer has nearly run out of toner. Buy a new toner cartridge and have it ready before you get a **TONER LIFE END** message. To replace the toner cartridge, see *Replacing the toner cartridge* on page 75.

TONER LIFE END message

TONER LIFE END

If the LCD shows **TONER LIFE END**, the printer has run out of toner or the toner is not evenly distributed inside the cartridge.

In both situations, the printer will stop printing until a new toner cartridge has been put into the printer.

TONER LIFE END can only be cleared by putting a new toner cartridge into the drum unit.

Replacing the toner cartridge

Note

- To ensure high quality printing, we recommend that you use only genuine Brother toner cartridges. When you want to buy toner cartridges, call the dealer you bought the printer from or Brother Customer Service.
- We recommend that you clean the printer when you replace the toner cartridge. See *Cleaning* on page 85.

- 1 Press the front cover release button and then open the front cover.

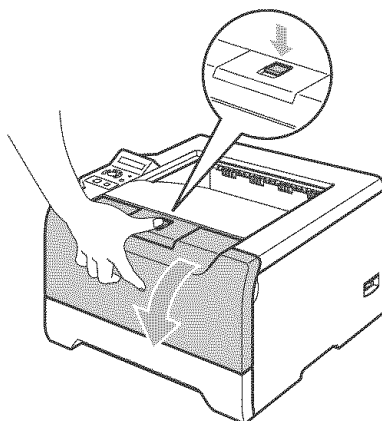

- 2 Take out the drum unit and toner cartridge assembly.

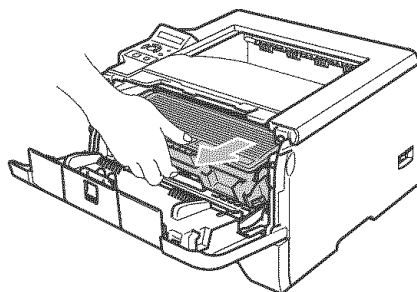

CAUTION

We recommend that you put the drum unit and toner cartridge assembly on a piece of disposable paper or cloth in case you accidentally spill or scatter toner.

To prevent damage to the printer from static electricity, DO NOT touch the electrodes shown in the illustration.

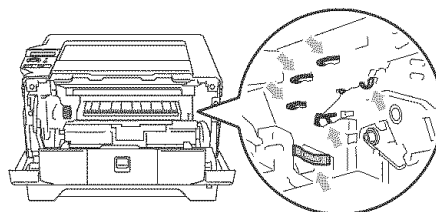

- 3 Push down the blue lock lever and take the toner cartridge out of the drum unit.

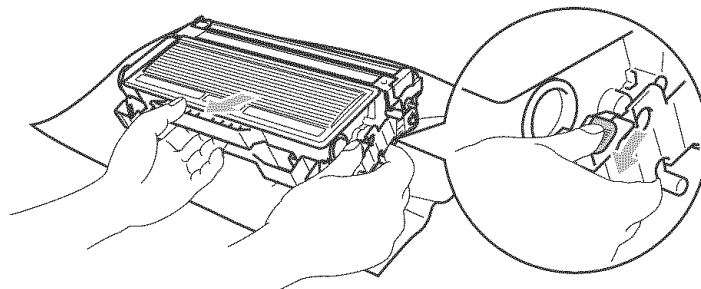

CAUTION

DO NOT put a toner cartridge into a fire. It could explode, resulting in injuries.

Handle the toner cartridge carefully. If toner scatters on your hands or clothes, wipe or wash it off with cold water at once.

To avoid print quality problems, DO NOT touch the shaded parts shown in the illustrations.

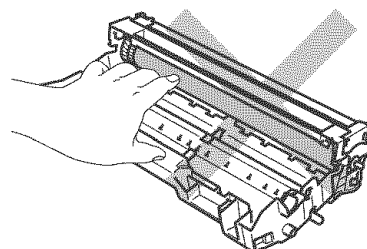
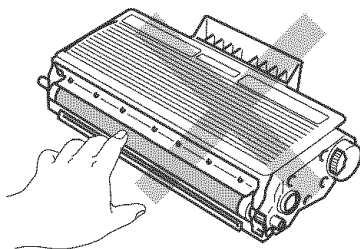

Note

- Be sure to seal up the toner cartridge tightly in a bag so that toner powder does not spill out of the cartridge.
- Discard the used toner cartridge according to local regulations, keeping it separate from domestic waste. If you have questions, call your local waste disposal office.

- 4 Unpack the new toner cartridge. Hold the cartridge level with both hands and gently rock it from side to side five or six times to spread the toner evenly inside the cartridge.

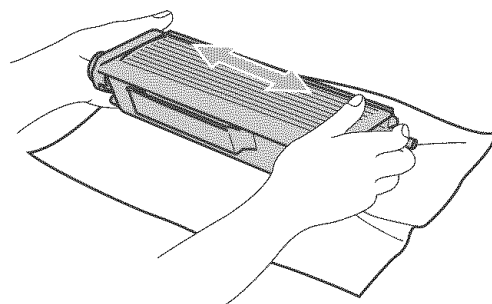

! CAUTION

Wait to unpack the toner cartridge until immediately before you put it in the printer. If toner cartridges are left unpacked for a long time the toner life will be shortened.

If an unpacked drum unit is put in direct sunlight or room light, the unit may be damaged.

Put the toner cartridge in the drum unit immediately after you have removed the protective cover. To prevent any degradation to the print quality, DO NOT touch the shaded parts shown in the illustrations.

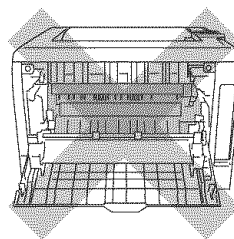
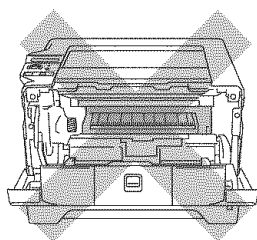
**! CAUTION****For USA and Canada**

Brother strongly recommends that you do not refill the toner cartridge provided with your printer. We also strongly recommend that you continue to use only genuine Brother brand replacement toner cartridges. Use or attempted use of potentially incompatible toner and/or cartridges in the Brother machine may cause damage to the machine and/or may result in unsatisfactory print quality. Our warranty coverage does not apply to any problem that is caused by the use of unauthorized third party toner and/or cartridges. To protect your investment and obtain premium performance from the Brother machine, we strongly recommend the use of genuine Brother supplies.

! CAUTION**For UK and other countries**

Brother machines are designed to work with toner of a particular specification and will work to a level of optimum performance when used with genuine Brother branded toner cartridges. Brother cannot guarantee this optimum performance if toner or toner cartridges of other specifications are used. Brother does not therefore recommend the use of cartridges other than genuine Brother branded cartridges with this machine.

If damage is caused to the drum unit or other part of this machine as a result of using other manufacturer's products with this machine, any repairs required as a result may not be covered by the warranty.

- 5 Pull off the protective cover.

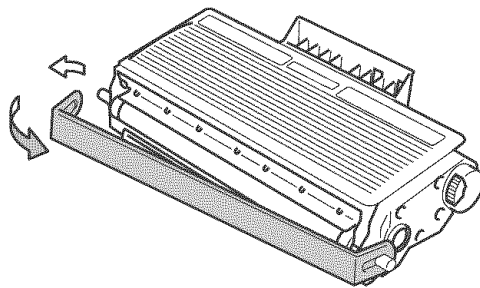

- 6 Put the new toner cartridge firmly into the drum unit until you hear it lock into place. If you put it in properly, the lock lever will lift automatically.

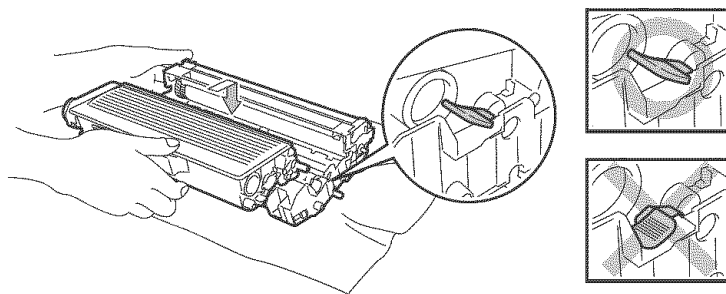

! CAUTION

Make sure that you put in the toner cartridge properly or it may separate from the drum unit.

- 7 Clean the primary corona wire inside the drum unit by gently sliding the blue tab from right to left and left to right several times.

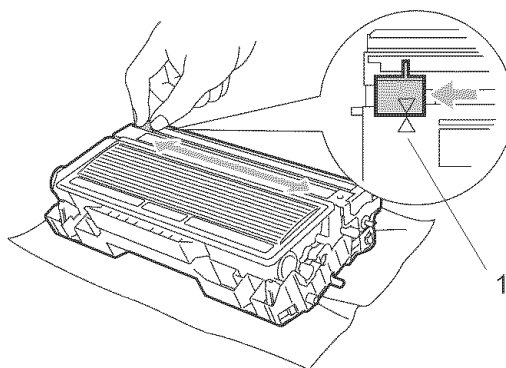

! CAUTION

Be sure to return the tab to the home position (▲) (1). If you do not, printed pages may have a vertical stripe.

- 8 Put the drum unit and toner cartridge assembly back in the printer. Close the front cover.

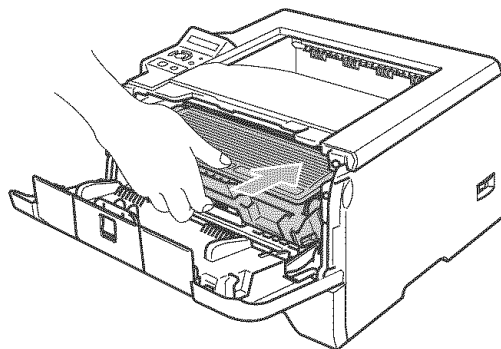

Drum unit

A new drum unit can print approximately 25,000 A4 or Letter size single-sided pages at 5% coverage.

Note

- There are many factors that determine the actual drum life, such as the temperature, humidity, type of paper, type of toner used, number of pages per print job and so on. Under ideal conditions, the average drum life is estimated at approximately 25,000 pages. The actual number of pages that your drum will print may be significantly less than this estimate. Because we have no control over the many factors that determine the actual drum life, we cannot guarantee a minimum number of pages that will be printed by your drum.
- For best performance, use only genuine Brother toner. The printer should be used only in a clean, dust-free environment with adequate ventilation.
- Printing with a third-party drum unit may reduce not only the print quality but also the quality and life of the printer itself. Warranty coverage does not apply to problems caused by the use of a third-party drum unit.

DRUM NEAR END message

DRUM NEAR END

If the LCD shows DRUM NEAR END, it means the drum unit is near the end of its life. We recommend that you replace the drum unit with a new one before there is a noticeable deterioration in the print quality.

Replacing the drum unit

CAUTION

While removing the drum unit, handle it carefully because it may contain toner.

Every time you replace the drum unit, clean the inside of the printer. See *Cleaning* on page 85.

When you replace the drum unit with a new one, you need to reset the drum counter by completing the following steps:

- 1 Press the front cover release button and then open the front cover.

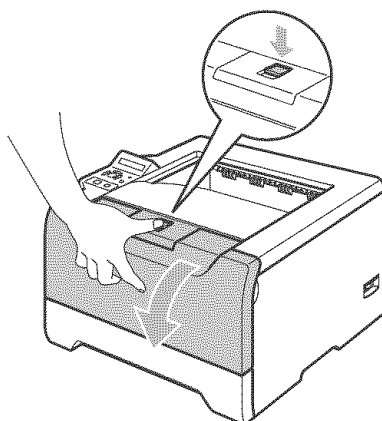

- 2 Hold down **Go** until the message **DRUM CLEAR** is displayed on the LCD, then release **Go**.

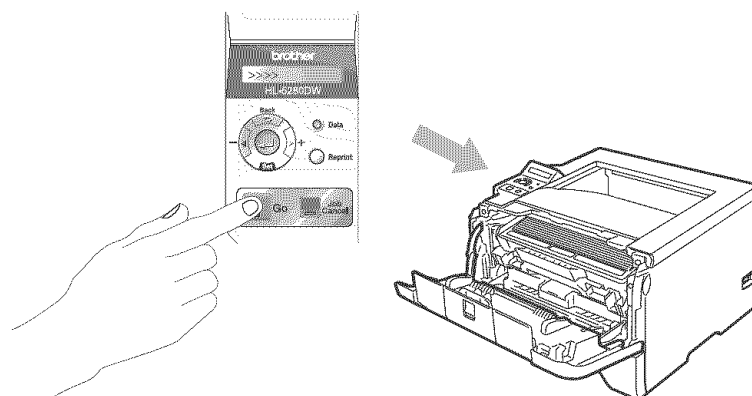

⊘ Improper Setup

Do not reset the drum counter when you replace only the toner cartridge.

- 3 Take out the drum unit and toner cartridge assembly.

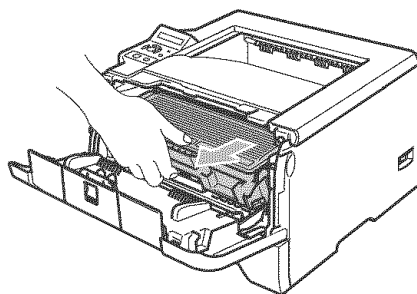

⚠ CAUTION

We recommend that you put the drum unit and toner cartridge assembly on a piece of disposable paper or cloth in case you accidentally spill or scatter toner.

To prevent damage to the printer from static electricity, **DO NOT** touch the electrodes shown in the illustration.

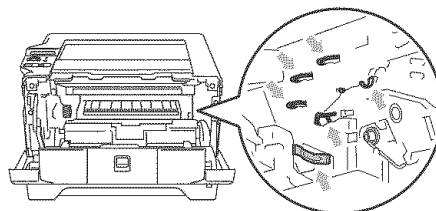

- 4 Push down the blue lock lever and take the toner cartridge out of the drum unit.

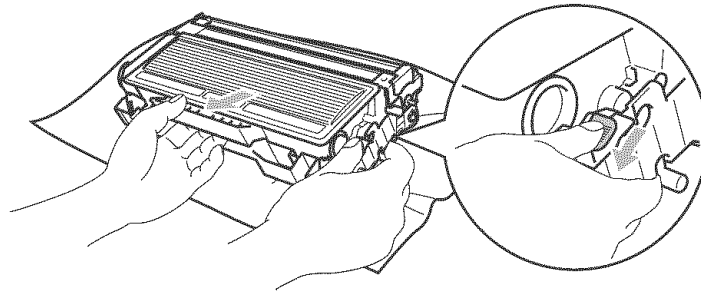

! CAUTION

Handle the toner cartridge carefully. If toner scatters on your hands or clothes, wipe or wash it off with cold water at once.

To avoid print quality problems, DO NOT touch the shaded parts shown in the illustrations.

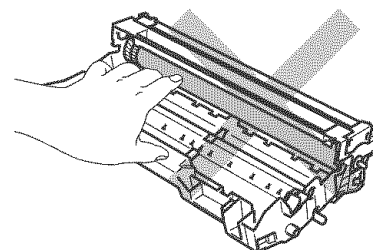
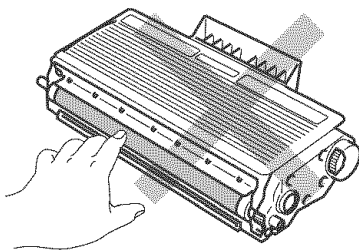

Note

- Be sure to seal up the drum unit tightly in a bag so that toner powder does not spill out of the unit.
- Discard the used drum unit according to local regulations, keeping it separate from domestic waste. If you have questions, call your local waste disposal office.

- 5 Unpack the new drum unit.

! CAUTION

Wait to unpack a drum unit until immediately before you put it in the printer. Exposure to direct sunlight or room light may damage the drum unit.

- 6 Put the toner cartridge firmly into the new drum unit until you hear it lock into place. If you put the cartridge in properly, the blue lock lever will lift automatically.

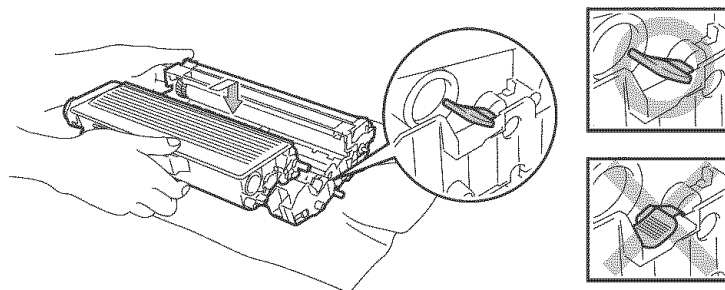

! CAUTION

Make sure that you put in the toner cartridge properly, or it may separate from the drum unit.

- 7 Put the drum unit and toner cartridge assembly back in the printer.

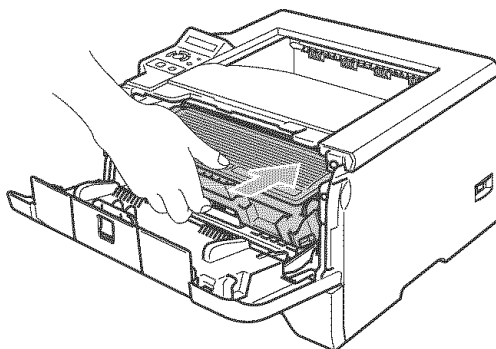

- 8 Close the front cover.

Replacing periodic maintenance parts

You need to replace the periodic maintenance parts regularly to maintain print quality. You should replace the parts listed below after printing the following number of pages.

LCD Message	LCD Description	Approximate Life	To Buy Replacement
REPLACE PF KITMP	Paper feeding kit for MP tray ¹	100,000 pages ³	Call Brother Customer Service
REPLACE PF KIT 1	Paper feeding kit for Tray 1 ²	100,000 pages ³	Call Brother Customer Service
REPLACE PF KIT 2	Paper feeding kit for Tray 2 ²	100,000 pages ³	Call Brother Customer Service
REPLACE PF KIT 3	Paper feeding kit for Tray 3 ²	100,000 pages ³	Call Brother Customer Service
REPLACE FUSER	Fuser unit	100,000 pages ³	Call Brother Customer Service
REPLACE LASER	Laser unit	100,000 pages ³	Call Brother Customer Service

¹ Paper feeding kit for MP tray means the paper pick up roller and the separation plate.

² Paper feeding kit for Tray 1, Tray 2 and Tray 3 means the paper feed roller, separation roller, separation pad and separation pad spring.

³ At 5% print coverage (A4 or Letter size). The actual number of printed pages will vary depending on the print jobs and paper you use.

Cleaning

Clean the outside and inside of the printer regularly with a dry, lint-free cloth. When you replace the toner cartridge or the drum unit, make sure that you clean the inside of the printer. If printed pages are stained with toner, clean the inside of the printer with a dry, lint-free cloth.

Cleaning the outside of the printer

! CAUTION

Use neutral detergents. Cleaning with volatile liquids such as thinner or benzine will damage the surface of the printer.

DO NOT use cleaning materials that contain ammonia.

- 1 Turn off the printer power switch and then unplug the printer.

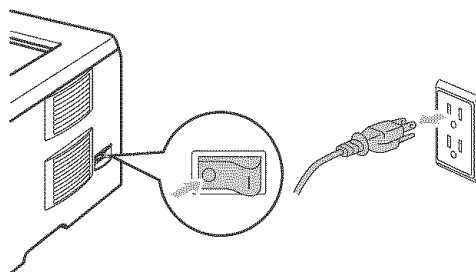

- 2 Pull the paper tray completely out of the printer.

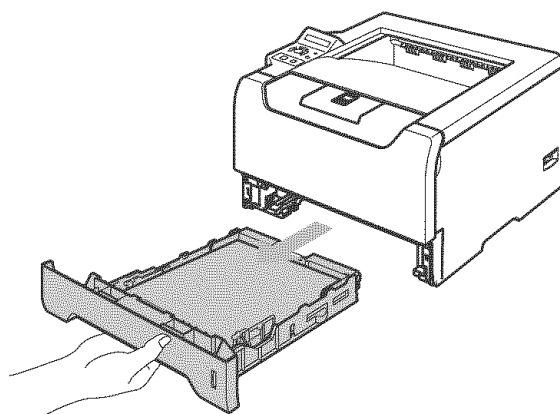

- 3 Wipe the outside of the printer with a dry, lint-free cloth to remove dust.

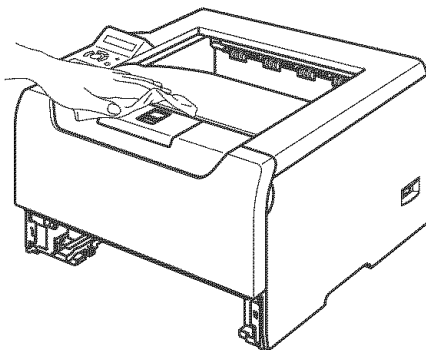

- 4 Remove anything that is stuck inside the paper tray.
- 5 Wipe the inside of the paper tray with a dry, lint-free cloth to remove dust.

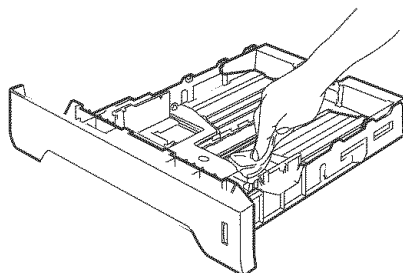

- 6 Put the paper tray back in the printer.
- 7 Plug the printer back in, and then turn on the power switch.

Cleaning the inside of the printer

- 1 Turn off the printer power switch and then unplug the printer.

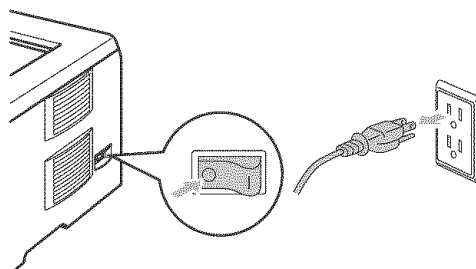

- 2 Press the front cover release button and then open the front cover.

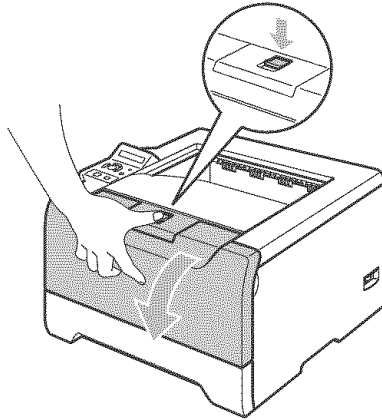

- 3 Take out the drum unit and toner cartridge assembly.

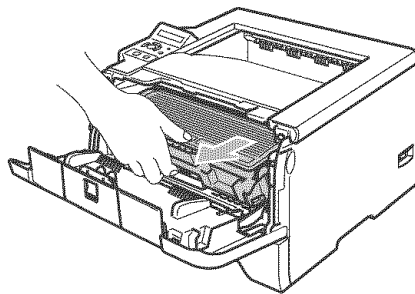
**HOT SURFACE**

After you have just used the printer, some internal parts of the printer will be extremely hot. Wait for the printer to cool down before you touch the internal parts of the printer.

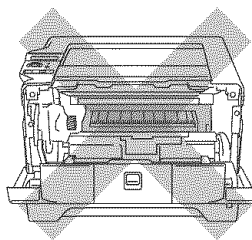
**CAUTION**

We recommend that you put the drum unit and toner cartridge assembly on a piece of disposable paper or cloth in case you accidentally spill or scatter toner.

Handle the toner cartridge carefully. If toner scatters on your hands or clothes, wipe or wash it off with cold water at once.

To prevent damage to the printer from static electricity, DO NOT touch the electrodes shown in the illustration.

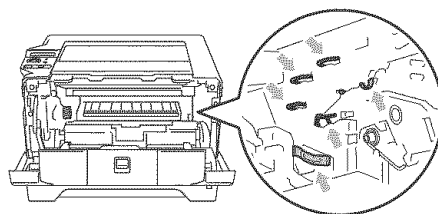

- 4 Wipe the scanner window with a dry, lint-free cloth.

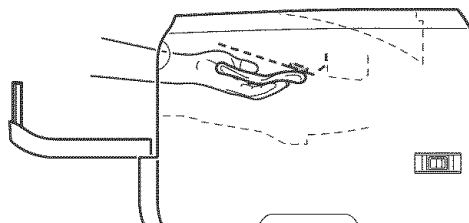
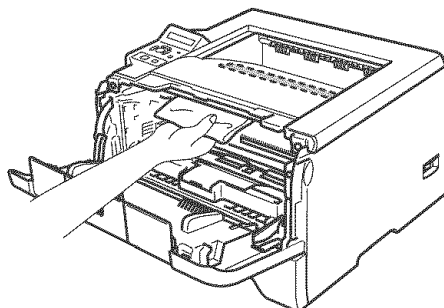

- 5 Put the drum unit and toner cartridge assembly back in the printer.
- 6 Close the front cover.
- 7 Plug the printer back in, and then turn on the power switch.

Cleaning the corona wire

If you have print quality problems, clean the corona wire as follows:

- 1 Press the front cover release button and then open the front cover.

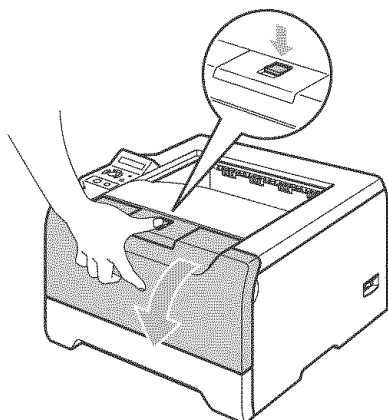

- 2 Take out the drum unit and toner cartridge assembly.

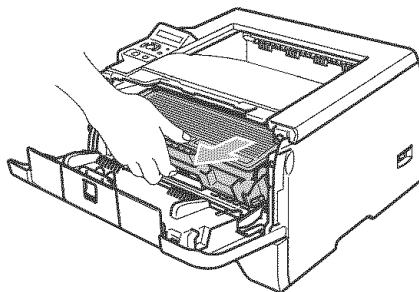

! CAUTION

We recommend that you put the drum unit and toner cartridge assembly on a piece of disposable paper or cloth in case you accidentally spill or scatter toner.

To prevent damage to the printer from static electricity, DO NOT touch the electrodes shown in the illustration.

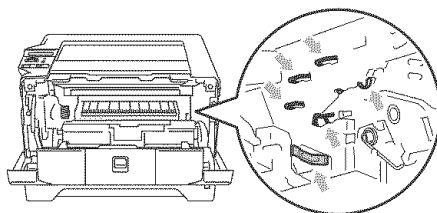

- 3 Clean the primary corona wire inside the drum unit by gently sliding the blue tab from right to left and left to right several times.

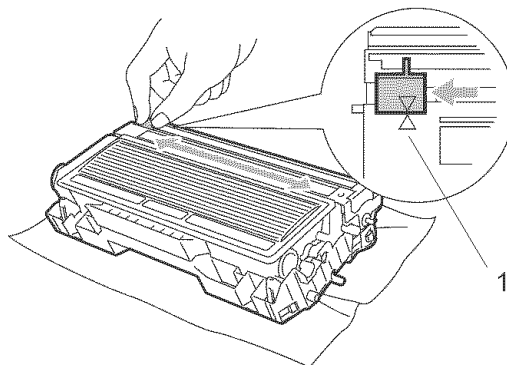
**! CAUTION**

Be sure to return the tab to the home position (▲) (1). If you do not, printed pages may have a vertical stripe.

- 4 Put the drum unit and toner cartridge assembly back in the printer. Close the front cover.

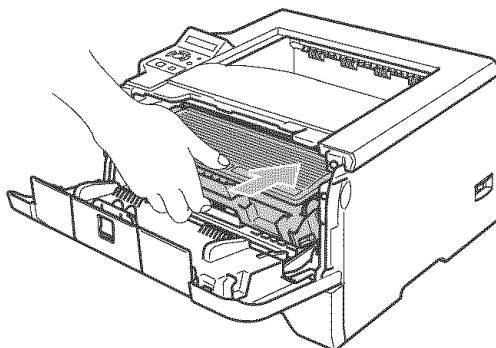

You can correct most problems by yourself. If you need additional help, the Brother Solutions Center offers the latest FAQs and troubleshooting tips. Visit us at <http://solutions.brother.com>.

Identifying your problem

First, check the following:

- The AC power cord is connected properly and the printer is turned on.
- All of the protective parts have been removed.
- The toner cartridge and drum unit are installed properly.
- The front and back covers are fully closed.
- Paper is inserted properly in the paper tray.
- The interface cable is securely connected to the printer and the computer.
- The correct driver for the printer has been chosen and is installed.
- The PC is set up to connect to the correct printer port.

Printer does not print:

If you did not solve your problem with the above checks, identify your problem and then go to the page suggested below.

■ LCD Messages

See *LCD messages* on page 92.

■ Printer printed an Error Message

See *Error message printout* on page 94.

■ Paper handling

See *Paper handling* on page 95 and *Paper jams and how to clear them* on page 96.

■ Other problems

See *Other problems* on page 112.

Pages are printed, but there are problems with:

■ Print quality

See *Improving the print quality* on page 105.

■ Printout is incorrect

See *Solving print problems* on page 111.

LCD messages

If any problems occur, the printer automatically stops printing, diagnoses the problem, and displays the resulting message on the LCD to alert you. Use the table below to identify and clear the error message. If you cannot clear the problem, call the dealer you bought the printer from or Brother Customer Service.



Note

The LCD names for the paper trays are as follows.

- Standard paper tray: TRAY1
- Multi-purpose tray: MP
- Optional Lower tray: TRAY2 or TRAY3

Error message

Error message	Action
BUFFER ERROR	Check the Interface settings.
CARTRIDGE ERROR	Take out the drum unit assembly and put it back into the printer again.
DIMM ERROR	Re-install the DIMM correctly. Turn off the printer. Wait a few seconds, and then turn it on again. If this error message appears again, replace the DIMM with a new one.
DOWNLOAD FULL	Add more memory. See <i>Installing extra memory</i> on page 71.
DUPLEX DISABLED	Close the back cover of the printer and put the duplex tray back in.
DUST ON DRUM	Open the front cover. Take out the drum unit and toner cartridge assembly. Gently slide the blue tab of the drum unit across several times.
FONT FULL	Add more memory. See <i>Installing extra memory</i> on page 71.
FRONT COVER OPEN	Close the front cover of the printer.
FUSER COVER OPEN	Close the fuser cover located behind the back cover of the printer.
JAM XXX	Carefully pull out the jammed paper from the area shown in <i>Paper jams and how to clear them</i> on page 96.
MANUAL FEED	Put the same size of paper in the MP tray as is shown on the LCD. If the printer is 'paused', press Go .
MEMORY FULL	Add more memory. See <i>Installing extra memory</i> on page 71 and <i>Solving print problems</i> on page 111.
NO PAPER	Put paper in the empty tray. If the error was not cleared when you put paper in the tray, match the size of the paper that you selected in the application with the TRAY SIZE or set the TRAY SIZE to ANY using the control panel.

Error message (Continued)

Error message	Action
NO PAPER XXX	Put paper in the empty tray.
NO TRAY XXX	Put the paper tray in the printer.
PRINT OVERRUN	Cut the resolution or add the optional memory. See <i>Installing extra memory</i> on page 71 and <i>Solving print problems</i> on page 111. Set Page Protection to the correct size. See <i>Device Options</i> on page 31 and <i>Menu table</i> on page 56.
SIZE ERROR DX	You can only use A4, Letter and Legal size for duplex printing. Check the printer driver setting and put the correct sized paper in the paper tray or MP tray that is selected in the printer driver. See <i>About paper</i> on page 6.
SIZE MISMATCH	Put the same size paper in the paper tray or MP tray that is selected in the printer driver, and then press Go , or select the size of paper you set in the TRAY SIZE setting from the control panel.
STORAGE FULL	The RAMDISK size is set to 0 MB. Increase the RAMDISK size. Or there is no space to store jobs. Delete unnecessary macros or fonts.
TOO MANY TRAYS	Maximum number of optional trays is two. Remove additional trays.

Maintenance messages

Maintenance message	Action
DRUM NEAR END	The drum unit is near the end of its life. Buy a new drum unit to replace the current one. See <i>DRUM NEAR END message</i> on page 80.
TONER LOW	Buy a new toner cartridge and have it ready before you get a TONER LIFE END message.
TONER LIFE END	See <i>Replacing the toner cartridge</i> on page 75.
REPLACE PF KITMP	Call your dealer or Brother Customer Service for a replacement paper feeding kit (paper pick up roller and separation plate) for the MP tray.
REPLACE PF KIT 1	Call your dealer or Brother Customer Service for a replacement paper feeding kit (paper feed roller, separation roller, separation pad, and separation pad spring) for Tray 1.
REPLACE PF KIT 2	Call your dealer or Brother Customer Service for a replacement paper feeding kit (paper feed roller, separation roller, separation pad, and separation pad spring) for Tray 2.
REPLACE PF KIT 3	Call your dealer or Brother Customer Service for a replacement paper feeding kit (paper feed roller, separation roller, separation pad, and separation pad spring) for Tray 3.
REPLACE FUSER	Call your dealer or Brother Customer Service for a replacement fuser unit.
REPLACE LASER	Call your dealer or Brother Customer Service for a replacement laser unit.

Call service messages

Call service message	Action
ERROR ###	Turn off the printer. Wait a few seconds, then turn it on again. If this does not clear the problem, call your dealer or a Brother Customer Service.

Error message printout

The printer can also report problems by printing an error message. Use the table below to identify and clear the error message. The default setting for the error message printout is off. If you want to turn the error message printout on, from the **Advanced** tab of the Windows printer driver click the **Device Options** icon, and then choose **Error Message Printout**.

Error message	Action
MEMORY FULL	<ul style="list-style-type: none"> ■ Press Go to print the remaining data in the printer memory. Cancel the print job if you want to delete the remaining data in the printer memory. See <i>Buttons</i> on page 48. ■ Reduce the complexity of your document or cut the print resolution. ■ Add more memory. See <i>Installing extra memory</i> on page 71.
PRINT OVERRUN	<ul style="list-style-type: none"> ■ Press Go to print the remaining data in the printer memory. Cancel the print job if you want to delete the remaining data in the printer memory. See <i>Buttons</i> on page 48. ■ If this does not clear the error, reduce the complexity of your document or cut the print resolution. ■ Add more memory. See <i>Installing extra memory</i> on page 71. ■ Set page protection to AUTO by using the supplied Windows® driver or the control panel. ■ Change the following settings in the supplied Windows® driver and try again. The best combination of these settings will vary depending on your document: <ul style="list-style-type: none"> • Graphics mode • TrueType mode • Use Printer TrueType® Fonts
RESOLUTION REDUCED TO ENABLE PRINTING (The printer has printed the document at a reduced resolution)	<ul style="list-style-type: none"> ■ Reduce the complexity of your document before you print to prevent automatic reduction in the resolution.

Paper handling

First, make sure that you are using paper that meets Brother recommended paper specifications. See *About paper* on page 6.

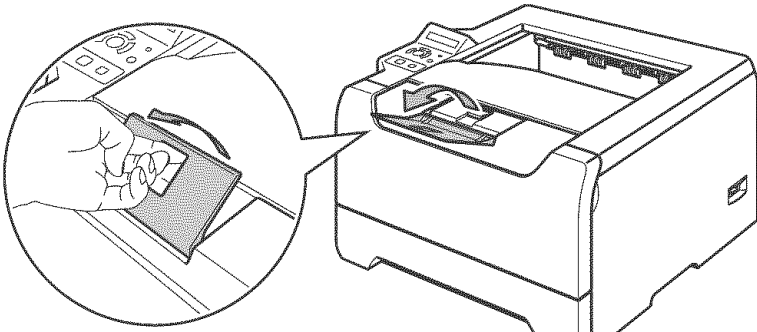
Problem	Recommendation
The printer does not feed paper.	<ul style="list-style-type: none"> ■ If there is paper in the paper tray, make sure it is straight. If the paper is curled, straighten it before printing. Sometimes it is helpful to remove the paper. Turn the stack over and put it back in the paper tray. ■ Cut the amount of paper in the paper tray, and then try again. ■ Make sure that manual feed mode is not chosen in the printer driver.
The printer does not feed paper from the MP tray.	<ul style="list-style-type: none"> ■ Fan the paper well and put it back in firmly. ■ Make sure that you have chosen the MP Tray in the Paper Source of the printer driver.
The printer does not feed envelopes.	<ul style="list-style-type: none"> ■ The printer can feed envelopes from the multi-purpose tray. You must set up your application to print on the size of envelopes you are using. This is usually done in the page setup or document setup menu of your software. See your application manual.
A paper jam has occurred.	<ul style="list-style-type: none"> ■ Clear the jammed paper. See <i>Paper jams and how to clear them</i> on page 96.
The printer does not print.	<ul style="list-style-type: none"> ■ Make sure that the cable is connected to the printer. ■ Make sure that you have chosen the proper printer driver.
When printing on normal paper, it creases.	<ul style="list-style-type: none"> ■ Change the printer driver setting in Media Type to a thin setting.
When printing on Legal size paper or longer sized paper, the paper slides off the top output tray.	<ul style="list-style-type: none"> ■ Pull out and lift up the output tray support flap. 

Paper jams and how to clear them

If paper jams inside the printer, the printer will stop. One of the following LCD messages will appear to tell you where to find the jammed paper.

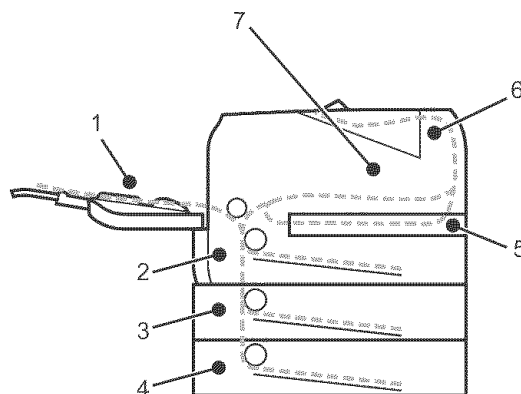

■ JAM MP TRAY (1)

Paper jam in the MP tray.

■ JAM TRAY1 (2)

Paper jam in the standard paper tray (TRAY 1).

■ JAM TRAY2 (3)

Paper jam in the lower tray (TRAY 2).

■ JAM TRAY3 (4)

Paper jam in the lower tray (TRAY 3).

■ JAM DUPLEX (5)

Paper jam in the duplex tray.

■ JAM REAR (6)

Paper jam where the paper comes out of the printer.

■ JAM INSIDE (7)

Paper jam inside the printer.

Check where the jam is and clear the jammed paper as follows.

If the error message still appears on the LCD after you remove the jammed paper, there may be more paper jammed somewhere else. Check the printer thoroughly.

After you have removed all the jammed paper, open the front cover and then close it again to start printing.



Note

Always remove all paper from the paper tray and straighten the stack when you add new paper. This helps prevent multiple sheets of paper from feeding through the printer at one time and prevents paper jams.

JAM MP TRAY (Paper jam in the MP tray)

JAM MP TRAY

If a paper jam occurs inside the MP tray, follow these steps:

- ① Remove the paper from the MP tray.
- ② Press the cover release button and then open the front cover.
- ③ Take out the drum unit and toner cartridge assembly.
- ④ Remove any paper from in and around the MP Tray, and then put the drum unit and toner cartridge assembly back in the printer and close the front cover.
- ⑤ Fan the paper stack, and then put it back in the MP tray.



- ⑥ When loading paper in the MP tray, make sure that it touches the back of the tray and stays under the maximum paper height guides on both sides of the tray.
- ⑦ If the printer does not automatically start printing, open the front cover and close it, or press **Go** to start printing.

JAM TRAY 1 / TRAY 2 / TRAY 3 (Paper jam inside the paper tray)



Note

The LCD names for the paper trays are as follows.

- Standard paper tray: TRAY1
- Optional Lower tray: TRAY2 or TRAY3

JAM TRAY1

JAM TRAY2

JAM TRAY3

If a paper jam occurs inside the paper tray, follow these steps:

- 1 Pull the paper tray completely out of the printer.

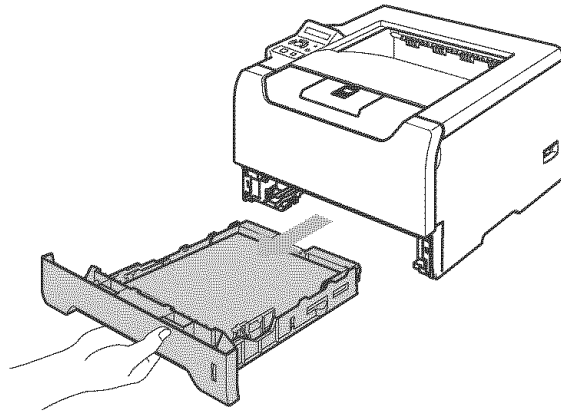

- 2 Use both hands to slowly pull out the jammed paper.

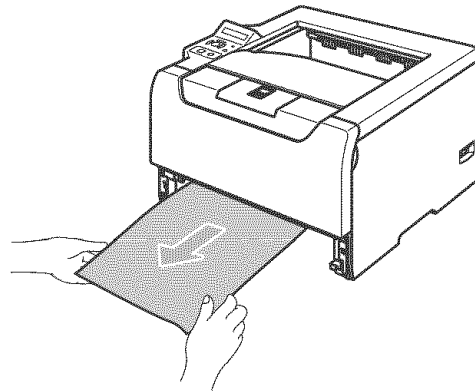

- 3 Put paper below the maximum paper mark (▼). While pressing the blue paper-guide release lever, slide the paper guides to fit the paper size. Make sure that the guides are firmly in the slots.
- 4 Put the paper tray firmly back in the printer.
- 5 Open the front cover and close it to resume printing.

! CAUTION

DO NOT take out the standard paper tray while paper is feeding from a lower paper tray because this may cause a paper jam.

JAM INSIDE (Paper jam inside the printer)

JAM INSIDE



HOT SURFACE

After you have just used the printer, some internal parts of the printer will be extremely hot. When you open the front cover or back cover of the printer, DO NOT touch the shaded parts shown in the illustrations.

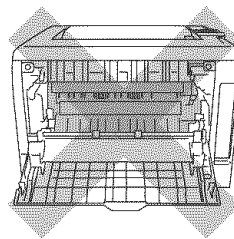
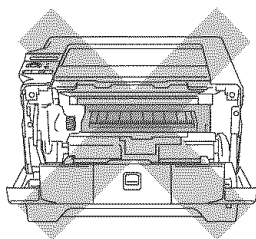

If a paper jam occurs inside the printer, follow these steps:

- 1 Press the front cover release button and then open the front cover.

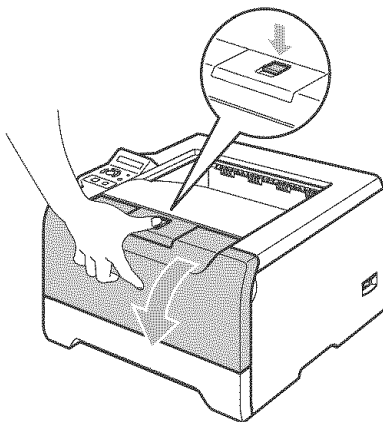

- 2 Slowly take out the drum unit and toner cartridge assembly. The jammed paper will be pulled out with the drum unit and toner cartridge assembly.

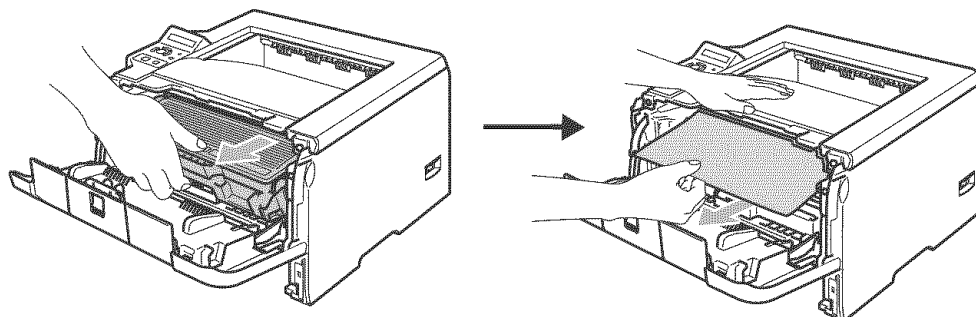

! CAUTION

After you have removed the jammed paper, print a few test pages. This is to make sure that the printed pages have no toner stains on them before you restart the print job.

Remove the jammed paper carefully so you do not spread toner.

Take care not to stain your hands and clothes with toner. Wash toner stains at once with cold water.

We recommend that you put the drum unit and toner cartridge assembly on a piece of disposable paper or cloth in case you accidentally spill the toner.

To prevent damage to the printer caused by static electricity, **DO NOT** touch the electrodes shown in the illustration.

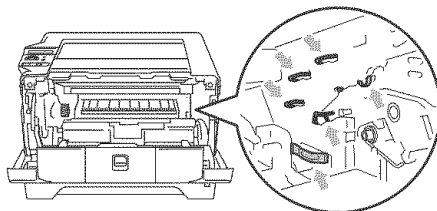

- 3 Push down the blue lock lever and take the toner cartridge out of the drum unit. Clear the jammed paper if there is any inside the drum unit.

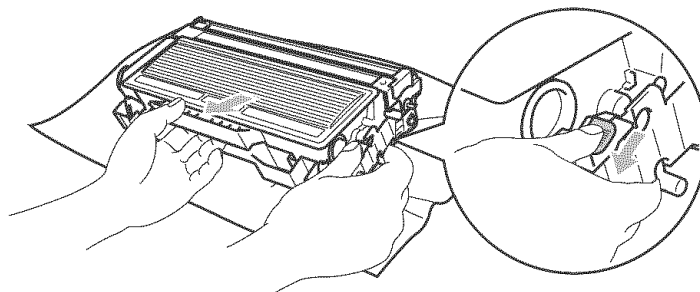
**! CAUTION**

Handle the toner cartridge carefully. If toner scatters on your hands or clothes, wipe or wash it off with cold water at once.

To avoid print quality problems, **DO NOT** touch the shaded parts shown in the illustrations.

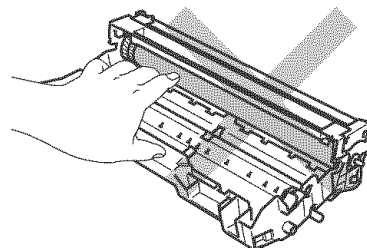
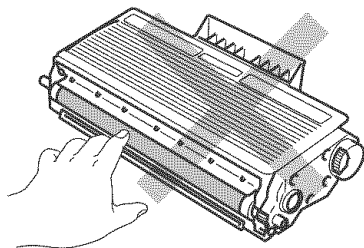

- 4 Put the toner cartridge back into the drum unit until you hear it lock into place. If you put the cartridge in properly, the blue lock lever will lift automatically.

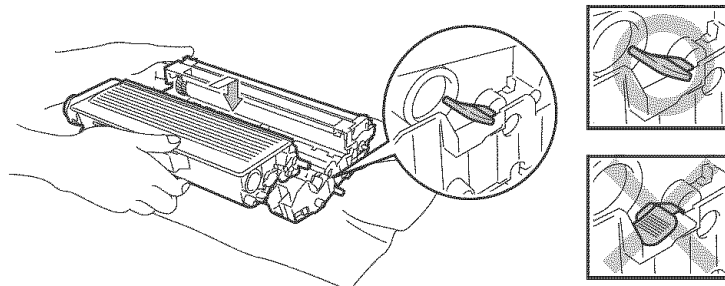

- 5 Close the front cover.

JAM REAR (Paper jam behind the back cover)

JAM REAR



HOT SURFACE

After you have just used the printer, some internal parts of the printer will be extremely hot. When you open the front cover or back cover of the printer, **DO NOT** touch the shaded parts shown in the illustrations.

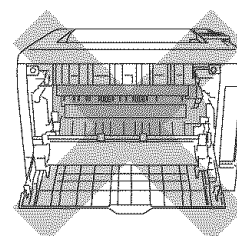
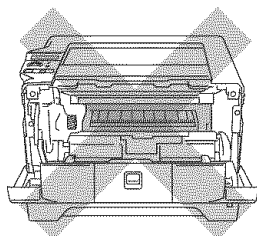

If a paper jam occurs behind the face-up output tray, follow these steps:

- 1 Press the cover release button and then open the front cover.

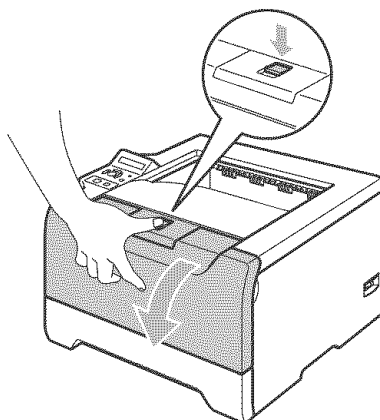

- 2 Slowly take out the drum unit and toner cartridge assembly. The jammed paper will be pulled out with the drum unit and toner cartridge assembly.

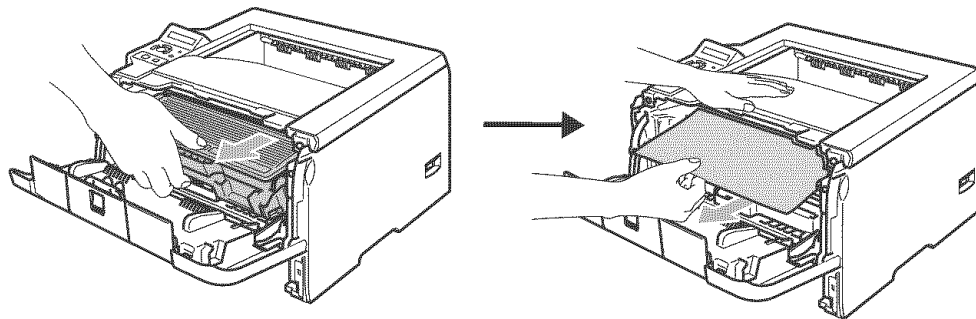

! CAUTION

We recommend that you put the drum unit and toner cartridge assembly on a piece of disposable paper or cloth in case you accidentally spill or scatter toner.

To prevent damage to the printer from static electricity, DO NOT touch the electrodes shown in the illustration.

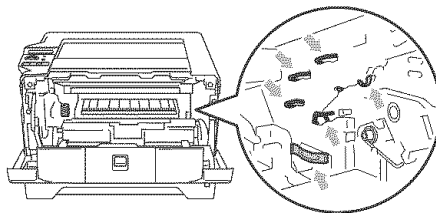

- 3 Open the back cover.

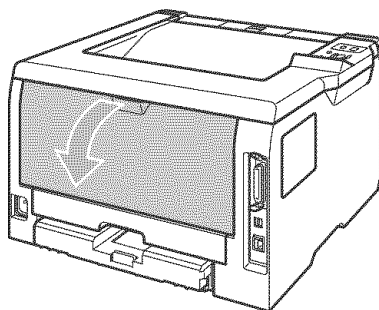

- 4 Pull the tabs at the left and right hand sides toward you to open the fuser cover (1).

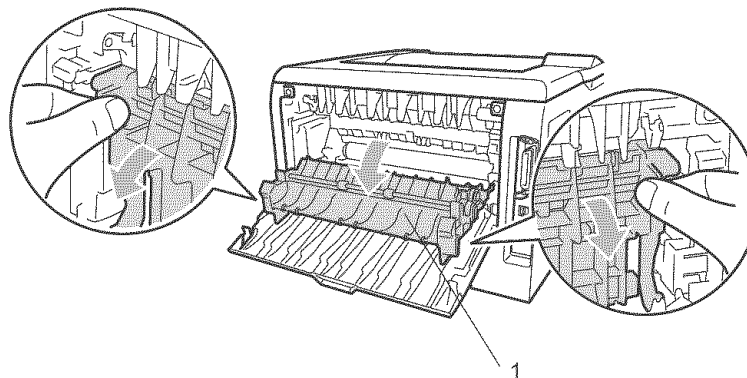

- 5 Using both hands, gently pull the jammed paper out of the fuser unit.

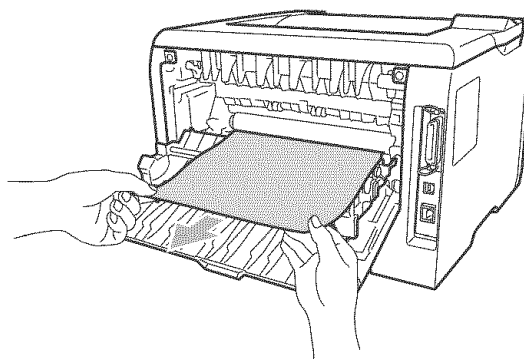

HOT SURFACE

After you have just used the printer, some internal parts of the printer will be extremely hot. Wait for the printer to cool down before you touch the internal parts of the printer.

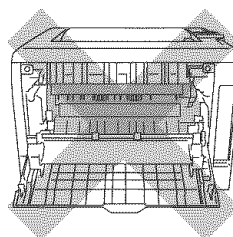

- 6 Put the drum unit and toner cartridge assembly back in the printer (press firmly).
- 7 Fully close the front and back covers.

JAM DUPLEX (Paper jam in the duplex tray)

JAM DUPLEX

If a paper jam occurs inside the duplex tray, follow these steps:

- 1 Pull the duplex tray completely out of the printer.

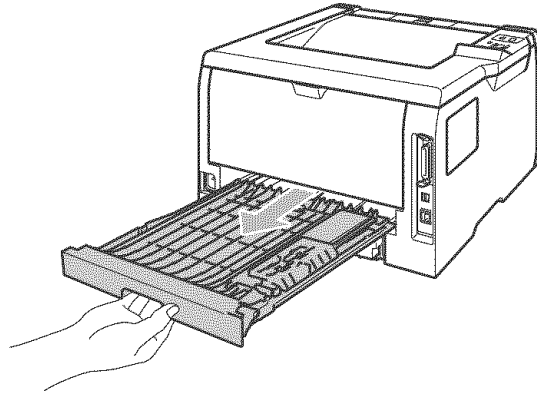

- 2 Pull the the jammed paper out of the printer or the duplex tray.

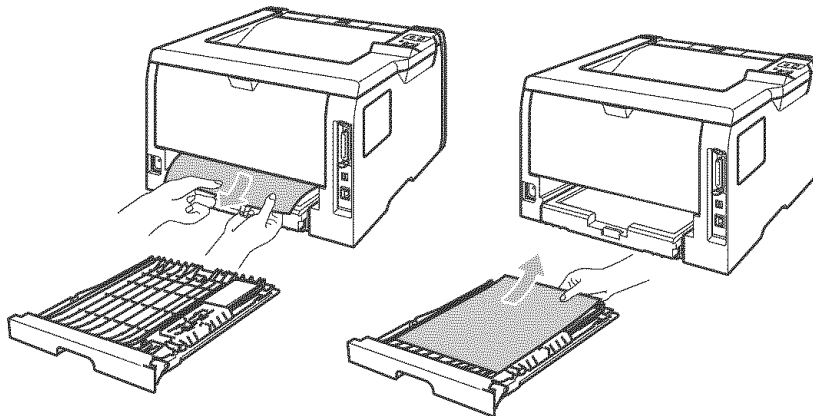





- 3 Put the duplex tray back in the printer.

Improving the print quality

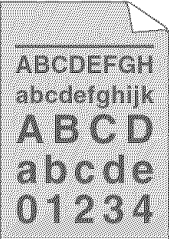
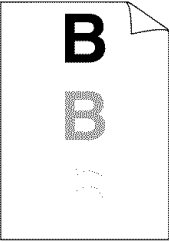
If you have a print quality problem, print a test page first (see *Menu table* on page 56). If the printout looks good, the problem is probably not the printer. Check the interface cable or try the printer on another PC.

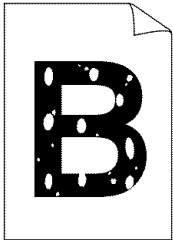
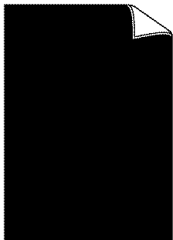

This section gives information on the following topics.

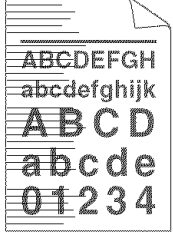
Examples of poor print quality	Recommendation
 <p>ABCDEF GH abcde fghijk A B C D a b c d e 0 1 2 3 4</p> <p>Faint</p>	<ul style="list-style-type: none"> ■ Check the printer's environment. Conditions such as humidity, high temperatures, and so on, may cause this print fault. See <i>Positioning the printer</i> on page 4. ■ If the whole page is too light, Toner Save Mode may be on. Turn off Toner Save Mode in the printer Properties tab of the driver. ■ Put in a new toner cartridge. See <i>Replacing the toner cartridge</i> on page 75. ■ Put in a new drum unit. See <i>Replacing the drum unit</i> on page 80. ■ You may clear the problem by wiping the scanner window with a soft cloth. See <i>Cleaning the inside of the printer</i> on page 86.
 <p>ABCDEF GH abcde fghijk A B C D a b c d e 0 1 2 3 4</p> <p>Gray background</p>	<ul style="list-style-type: none"> ■ Make sure that you use paper that meets our specifications. See <i>About paper</i> on page 6. ■ Check the printer's environment. Conditions such as high temperatures and high humidity can increase the amount of background shading. See <i>Positioning the printer</i> on page 4. ■ Put in a new toner cartridge. See <i>Replacing the toner cartridge</i> on page 75. ■ Put in a new drum unit. See <i>Replacing the drum unit</i> on page 80.
 <p>B B</p> <p>Ghost</p>	<ul style="list-style-type: none"> ■ Make sure that you use paper that meets our specifications. Rough-surfaced paper or thick print media may cause this problem. See <i>About paper</i> on page 6. ■ Make sure that the media type setting in the driver matches the type of paper you are using. See <i>About paper</i> on page 6. ■ Put in a new drum unit. See <i>Replacing the drum unit</i> on page 80. ■ The fuser unit may be contaminated. Call Brother Customer Service.
 <p>ABCDEF GH abcde fghijk A B C D a b c d e 0 1 2 3 4</p> <p>Toner specks</p>	<ul style="list-style-type: none"> ■ Make sure that you use paper that meets our specifications. Rough-surfaced paper may cause the problem. See <i>About paper</i> on page 6. ■ The drum unit may be damaged. Put in a new drum unit. See <i>Replacing the drum unit</i> on page 80. ■ The fuser unit may be contaminated. Call Brother Customer Service.

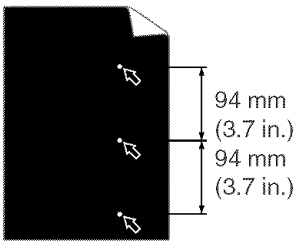
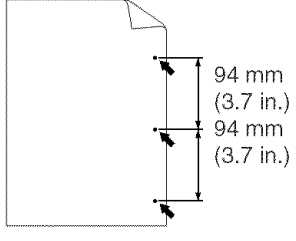
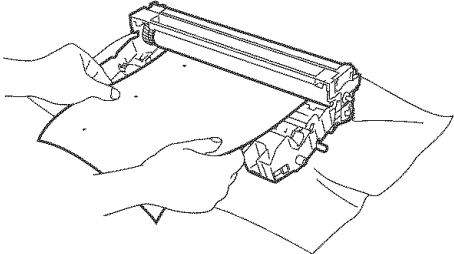
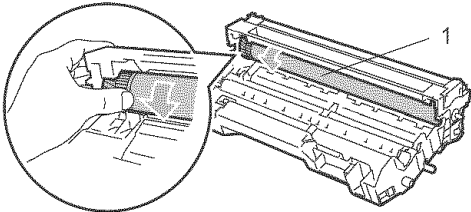
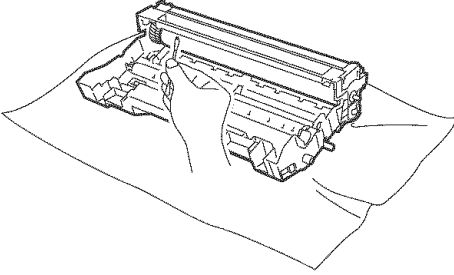
Examples of poor print quality	Recommendation
 <p data-bbox="250 590 404 617">Hollow print</p>	<ul style="list-style-type: none"> <li data-bbox="540 321 1503 380">■ Make sure that you use paper that meets our specifications. See <i>About paper</i> on page 6. <li data-bbox="540 396 1503 455">■ Choose Thick paper mode in the printer driver, or use thinner paper than what you are now using. <li data-bbox="540 472 1503 531">■ Check the printer's environment. Conditions such as high humidity can cause hollow print. See <i>Positioning the printer</i> on page 4.
 <p data-bbox="271 905 384 932">All black</p>	<ul style="list-style-type: none"> <li data-bbox="540 636 1503 724">■ Clean the primary corona wire inside the drum unit by sliding the blue tab. Be sure to return the blue tab to the home position (▲). See <i>Cleaning the corona wire</i> on page 89. <li data-bbox="540 741 1503 800">■ The drum unit may be damaged. Put in a new drum unit. See <i>Replacing the drum unit</i> on page 80. <li data-bbox="540 816 1373 844">■ The fuser unit may be contaminated. Call Brother Customer Service.
 <p data-bbox="151 1213 505 1241">White lines across the page</p>	<ul style="list-style-type: none"> <li data-bbox="540 951 1484 1010">■ Make sure that you use paper that meets our specifications. A rough surfaced paper or thick print media can cause problems. <li data-bbox="540 1026 1390 1054">■ Make sure that you choose the proper media type in the printer driver. <li data-bbox="540 1071 1503 1129">■ The problem may disappear by itself. Print multiple pages to clear this problem, especially if the printer has not been used for a long time. <li data-bbox="540 1146 1503 1205">■ The drum unit may be damaged. Put in a new drum unit. See <i>Replacing the toner cartridge</i> on page 75.
 <p data-bbox="188 1524 469 1551">Lines across the page</p>	<ul style="list-style-type: none"> <li data-bbox="540 1266 1451 1325">■ Clean the inside of the printer and the primary corona wire in the drum unit. See <i>Cleaning</i> on page 85. <li data-bbox="540 1341 1503 1400">■ The drum unit may be damaged. Put in a new drum unit. See <i>Replacing the drum unit</i> on page 80.

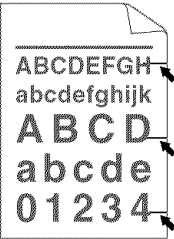
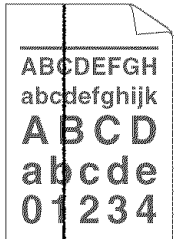
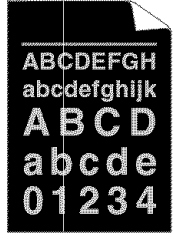
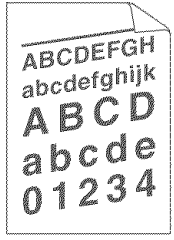
Examples of poor print quality	Recommendation
 <p>White Spots on black text and graphics at 94 mm (3.7 in.) intervals</p>  <p>Black Spots at 94 mm (3.7 in.) intervals</p>	<ul style="list-style-type: none"> ■ If the problem is not solved after printing a few pages, the drum unit may have glue from the label stuck on the OPC drum surface. <p>Clean the drum unit as follows:</p> <ol style="list-style-type: none"> ① Put the print sample in front of the drum unit, and find the exact position of the poor print.  ② Turn the drum unit gear by hand while looking at the surface of the OPC drum (1).  ③ When you have found the mark on the drum that matches the print sample, wipe the surface of the OPC drum with a cotton swab until the dust or paper powder on the surface comes off.  <p>! CAUTION</p> <p>DO NOT clean the surface of the photosensitive drum with a sharp object.</p> <ul style="list-style-type: none"> ■ The drum unit may be damaged. Put in a new drum unit. See <i>Replacing the drum unit</i> on page 80.

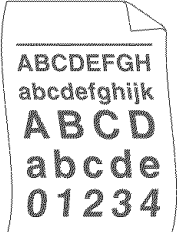
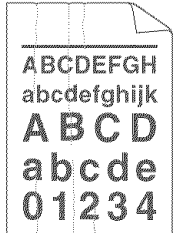
Examples of poor print quality	Recommendation
 <p>Black toner marks across the page</p>	<ul style="list-style-type: none"> ■ The drum unit may be damaged. Put in a new drum unit. See <i>Replacing the drum unit</i> on page 80. ■ Make sure that you use paper that meets our specifications. See <i>About paper</i> on page 6. ■ If you use label sheets for laser printers, the glue from the sheets may sometimes stick to the OPC drum surface. Clean the drum unit. See on <i>Clean the drum unit as follows:</i> on page 107. ■ Do not use paper that has clips or staples because they will scratch the surface of the drum. ■ If the unpacked drum unit is in direct sunlight or room light, the unit may be damaged.
 <p>Black lines down the page Printed pages have toner stains down the page.</p>	<ul style="list-style-type: none"> ■ Clean the primary corona wire inside the drum unit by sliding the blue tab. See <i>Cleaning the corona wire</i> on page 89. ■ Make sure the primary corona wire cleaner is at the home position (▲). ■ The drum unit may be damaged. Put in a new drum unit. See <i>Replacing the drum unit</i> on page 80. ■ The toner cartridge may be damaged. Put in a new toner cartridge. See <i>Replacing the toner cartridge</i> on page 75. ■ The fuser unit may be smudged. Call your dealer or Brother Customer Service.
 <p>White lines down the page</p>	<ul style="list-style-type: none"> ■ Make sure that a torn piece of paper is not inside the printer covering the scanner window. ■ Wipe the scanner window with a soft cloth. See <i>Cleaning the inside of the printer</i> on page 86. ■ The toner cartridge may be damaged. Put in a new toner cartridge. See <i>Replacing the toner cartridge</i> on page 75. ■ The drum unit may be damaged. Put in a new drum unit. See <i>Replacing the drum unit</i> on page 80.
 <p>Page skewed</p>	<ul style="list-style-type: none"> ■ Make sure that the paper or other print media is loaded properly in the paper tray and that the guides are not too tight or too loose against the paper stack. ■ Set the paper guides correctly. See <i>Printing on plain paper, bond paper or transparencies from Tray 1, 2 or 3</i> on page 10. ■ If you are using the multi-puroise tray, see <i>Printing on plain paper, bond paper or transparencies from the MP tray</i> on page 13. ■ The paper tray may be too full. See <i>Printing on plain paper, bond paper or transparencies from Tray 1, 2 or 3</i> on page 10. ■ Check the paper type and quality. See <i>About paper</i> on page 6.

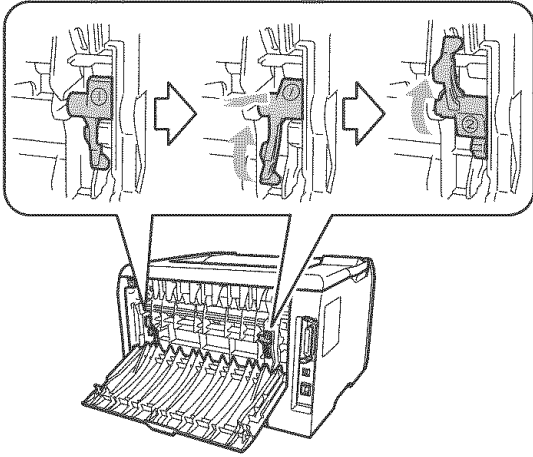
Examples of poor print quality	Recommendation
 <p>Curled or wavy</p>	<ul style="list-style-type: none"> ■ Check the paper type and quality. High temperatures and high humidity will cause paper to curl. See <i>About paper</i> on page 6. ■ If you do not use the printer often, the paper may have been in the paper tray too long. Turn over the stack of paper in the paper tray. Also, fan the paper stack and then rotate the paper 180° in the paper tray.
 <p>Wrinkles or creases</p>	<ul style="list-style-type: none"> ■ Make sure that the paper is loaded properly. See <i>Printing on plain paper, bond paper or transparencies from Tray 1, 2 or 3</i> on page 10. ■ Check the paper type and quality. See <i>About paper</i> on page 6. ■ Turn over the stack of paper in the tray or try rotating the paper 180° in the input tray.
 <p>Envelope Creases</p>	<ol style="list-style-type: none"> 1 Open the back cover. 2 Press against the "1" on the blue levers on either side of the printer as shown below. 3 As the top of the lever rotates backward, lift the bottom portion of the lever from below until it stops. 4 Close the back cover and resend the print job.  <p>Note When you have finished printing, open the back cover and reset the two blue levers back to their original position.</p>

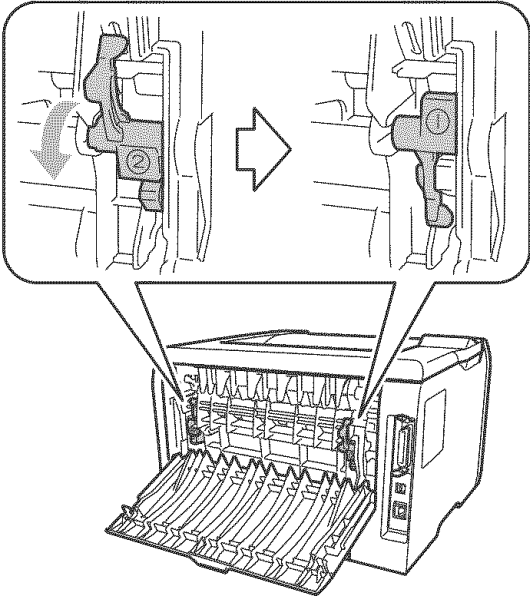
Examples of poor print quality	Recommendation
 <p>Poor Fixing</p>	<ul style="list-style-type: none">■ Open the back cover and make sure that the two blue levers on the left and right hand sides are in the down position. 

Solving print problems

Problem	Recommendation
<p>The printer prints unexpectedly or it prints garbage data.</p>	<ul style="list-style-type: none"> ■ Make sure that the printer cable is not too long. We recommend that you use a parallel or USB cable that is no longer than 2 meters (6.5 feet). ■ Make sure that the printer cable is not damaged or broken. ■ If you are using an interface-switching device, remove it. Connect your computer directly to your printer, and then try again. ■ Make sure that you have chosen the proper printer driver with 'Set as Default'. ■ Make sure that the printer is not connected to the same port that is also connected to a storage device or scanner. Take away all other devices and connect the port only to the printer. ■ Turn off the Status Monitor in the Device Options tab in the Windows® printer driver.
<p>The printer cannot print full pages of a document. An error message MEMORY FULL is appears.</p>	<ul style="list-style-type: none"> ■ Press Go to print the remaining data in the printer memory. Cancel the print job if you want to delete the remaining data in the printer memory. See <i>Buttons</i> on page 48. ■ Reduce the complexity of your document or cut the print resolution. ■ Add more memory. See <i>Installing extra memory</i> on page 71.
<p>The printer cannot print full pages of a document. An error message PRINT OVERRUN is appears.</p>	<ul style="list-style-type: none"> ■ Press Go to print the remaining data in the printer memory. Cancel the print job if you want to delete the remaining data in the printer memory. See <i>Buttons</i> on page 48. ■ Reduce the complexity of your document or cut the print resolution. ■ Add more memory. See <i>Installing extra memory</i> on page 71. ■ Set page protection to AUTO by using the supplied Windows® driver or control pabel. ■ Change the following settings in the Windows® printer driver, and then try again. The best combination of the settings below will vary depending on your document: <ul style="list-style-type: none"> • Graphics mode • TrueType mode • Use printer TrueType® fonts
<p>The headers or footers appear when the document displays on the screen but they do not show up when it is printed.</p>	<ul style="list-style-type: none"> ■ Adjust the top and bottom margins of your document.

Network problems

For problems concerning using your printer on a Network, see the Network User's Guide on the CD-ROM we have supplied.

Other problems

Problem	Recommendation
The printer cannot print. The 'There was an error writing to LPT1: (or BRUSB) for the printer' error message occurs on your PC.	<ul style="list-style-type: none"> ■ Make sure that the printer cable is not damaged or broken. ■ If you have an interface-switching device, make sure that you chose the correct printer.

For Macintosh® with USB

Problem	Recommendation
The printer does not appear in Chooser (Mac OS® 9.1 to 9.2), Print Center (Mac OS® X 10.2) or Print Setup Utility (Mac OS® X 10.3 or greater).	<ul style="list-style-type: none"> ■ Make sure that the printer is turned on. ■ Make sure that the USB interface cable is connected correctly. ■ Make sure the printer driver is installed correctly.
Unable to print from the application.	<ul style="list-style-type: none"> ■ Make sure that the supplied Macintosh® printer driver is installed in the Hard Disk and that it is chosen with Chooser (Mac OS® 9.1 to 9.2), Print Center (Mac OS® X 10.2) or Print Setup Utility (Mac OS® X 10.3 or greater).

Printing from DOS

Problem	Recommendation
Cannot print from the application.	<ul style="list-style-type: none"> ■ Make sure that the DOS application interface settings match those of your printer. For example, if you are using a parallel printer cable, you would set your DOS application printer port to LPT1. ■ Check if the printer has any printer alarms. ■ Make sure that you have chosen a printer driver in your application that is supported by your Brother printer. For information about the printers your machine can emulate, see <i>About emulation modes</i> on page 45.

BR-Script 3

Problem	Recommendation
The print speed slows down.	Add optional memory. See <i>Installing extra memory</i> on page 71.
The printer cannot print EPS data that includes binary.	<p>You need the following settings to print EPS data:</p> <ol style="list-style-type: none"> ① From the Start menu, select Control Panel and then Printer ¹. ¹ Printers and Faxes for Windows® XP users. ② Right-click the Brother HL-5270DN/5280DW BR_Script3 series icon and select Properties. ③ From the Device Settings tab, choose TBCP (Tagged binary communication protocol) in Output Protocol.

CAUTION

Not following the instructions for using the printer may cause you to be responsible for all repairs.

A

Appendix

Printer specifications

Engine

Model		HL-5270DN	HL-5280DW
Technology		Electrophotographic	
Print speed		Up to 30 ppm (Letter size) ¹ , Up to 28 ppm (A4 size) ¹	
First print time		Less than 8.5 sec	
Resolution	Windows [®] 95/98/Me, Windows NT [®] 4.0 and Windows [®] 2000/XP	1200 dpi ² HQ1200 600 dpi 300 dpi	
	DOS	600 dpi	
	Mac OS [®]	1200 dpi ² HQ1200 600 dpi 300 dpi	
	Linux	600 dpi 300 dpi	

¹ From standard paper tray and optional paper tray 2

² If you use the high quality 1200 dpi setting (1200 × 1200 dpi) the print speed will be slower.

Controller

Model		HL-5270DN	HL-5280DW
Processor		266MHz	
Memory	Standard	32 MB	
	Option	1 DIMM slot; expandable up to 544 MB	
Interface	Standard	Hi-Speed USB 2.0 ¹ , IEEE 1284 Parallel, 10/100BASE-TX Ethernet	Hi-Speed USB 2.0 ¹ , IEEE 1284 Parallel, 10/100BASE-TX Ethernet, Wireless LAN IEEE 802.11b/g
	Network Connectivity	TCP/IP (Standard 10/100BASE-TX Ethernet)	
Network Connectivity	Protocols	TCP/IP (Standard 10/100BASE-TX Ethernet)	
	Management tool	BRAdmin Professional ²	
		BRAdmin Light ³	
		Web BRAdmin ⁴	
		Web Based Management ⁵	
Emulation		PCL6, BR-Script 3 (PostScript [®] 3™), Epson FX-850, IBM ProPrinter XL	
Resident fonts	PCL	66 scalable fonts, 12 bitmap fonts, 11 bar codes ⁶	
	PostScript [®] 3™	66 fonts	

¹ USB is not supported under Windows[®] 95 or Windows NT[®] 4.0.

² Brother original Windows[®] utility for printer and print server management.

³ Brother original Macintosh[®] utility for printer and print server management.

⁴ Server based management utility. Download from <http://solutions.brother.com>.

⁵ Printer and print server management through Web browser.

⁶ Code39, Interleaved 2 of 5, EAN-8, EAN-13, UPC-A, UPC-E, EAN-128, Codabar, FIM (US-PostNet), ISBN, Code128

Software

Model		HL-5270DN	HL-5280DW
Printer driver	Windows®	PCL Driver for Windows® 95/98/Me/2000/XP ¹ , Windows NT® 4.0	
		Generic PCL Driver for Windows NT® 4.0, Windows® 2000/XP	
		BR-Script 3 (PPD file) for Windows® 95/98/Me/2000/XP ¹ , Windows NT® 4.0.	
	Macintosh®	Brother Laser Driver for Mac OS® 9.1 to 9.2 and Mac OS® × 10.2.4 or greater	
		BR-Script 3 (PPD file) for Mac OS® 9.1 to 9.2 and Mac OS® × 10.2.4 or greater	
	Linux	LPR driver for Linux ²	
CUPS driver for Linux ²			
Utilities	Interactive Help ³		
	Driver Deployment Wizard ⁴		

¹ Download the printer driver for Windows® XP Professional x64 Edition from <http://solutions.brother.com>.

² Download the printer driver for Linux from <http://solutions.brother.com>.

³ Instructional animations for problem solving

⁴ The Driver Deployment Wizard automates the installation of printers in a peer-to-peer network.

Control panel

Model	HL-5270DN	HL-5280DW
LED	1 LED: Data LED	
LCD	1 line, 16 Digits, 3 colors	
Button	7 buttons: Go, Job Cancel, Reprint, Set, Back and 2 scroll buttons	

Paper handling

Model	HL-5270DN	HL-5280DW
Paper Input ¹	Multi-purpose tray	50 sheets
	Paper tray (Standard)	250 sheets
	Lower tray (Option)	250 sheets
Paper Output ¹	Face-down	150 sheets
Duplex	Manual Duplex	Yes
	Automatic Duplex	Yes

¹ Calculated with 80 g/m2 (21 lb) paper

Media specifications

Model		HL-5270DN	HL-5280DW
Media types	Multi-purpose tray	Plain paper, Bond paper, Recycled paper, Envelopes, Labels, Transparencies ¹ , Thin paper, Thick paper, Thicker paper	
	Paper tray	Plain paper, Bond paper, Recycled paper, Transparencies ¹ , Thin paper	
	Lower tray unit (Option) (LT-5300)	Plain paper, Bond paper, Recycled paper, Thin paper	
	Automatic duplex printing	Plain paper, Recycled paper	
Media weights	Multi-purpose tray	60 to 161 g/m ² (16 to 43 lb)	
	Paper tray	60 to 105 g/m ² (16 to 28 lb)	
	Lower tray unit (Option) (LT-5300)	60 to 105 g/m ² (16 to 28 lb)	
	Automatic duplex printing	60 to 105 g/m ² (16 to 28 lb)	
Media sizes	Multi-purpose tray	Width: 69.9 to 215.9 mm (2.75 to 8.5 in.) Length: 116 to 406.4 mm (4.57 to 16 in.)	
	Paper tray (Standard)	A4, Letter, Legal ² , B5 (ISO), Executive, A5, A6, B6 (ISO)	
	Lower tray unit (Option) (LT-5300)	A4, Letter, Legal ² , B5 (ISO), Executive, A5, B6 (ISO)	
	Automatic duplex printing	A4, Letter, Legal ²	

¹ Up to 10 sheets

² Legal size paper is not available in some regions outside the USA and Canada.

Supplies

Model		HL-5270DN	HL-5280DW
Toner	Standard cartridge	Approx. 3,500 pages A4/Letter pages @ 5% coverage	
	High yield cartridge	Approx. 7,000 pages A4/Letter pages @ 5% coverage	
Drum		Approx. 25,000 A4/Letter pages (1 page / job)	

Dimensions / Weights

Model	HL-5270DN	HL-5280DW
Dimensions (W × D × H)	393 × 384 × 259 mm (15.5 × 15.1 × 10.2 in.)	
Weights	Approx. 8.8 kg (19.4 lb), not including the drum unit and toner cartridge Approx. 10.0 kg (22.0 lb), including the drum unit and toner cartridge	

Other

Model		HL-5270DN	HL-5280DW
Power consumption	Printing	Average 610 W at 25 °C (77 °F)	Average 620 W at 25 °C (77 °F)
	Standby	Average 80 W at 25 °C (77 °F)	Average 80 W at 25 °C (77 °F)
	Sleep	Average 9 W	Average 12 W
Noise level	Sound Pressure	Printing	53 dB (A)
		Standby	27 dB (A)
	Sound power	Printing	LWAd = 6.7 Bell (A)
		Standby	LWAd = 4.3 Bell (A)
Ecology	Power save	Yes	
	Toner save ¹	Yes	

¹ We do not recommend Toner Save for printing Photo or Gray Scale images.

System Requirements

Computer Platform & Operating System Version		Processor Speed	Minimum RAM	Recommended RAM	Available Hard Disk Space
Windows [®]	95 ^{1 4} , 98, 98SE	486/66 MHz	8 MB	16 MB	40 MB
	NT [®] Workstation 4.0 ¹	Intel [®] Pentium [®] 75 MHz	16 MB	32 MB	50 MB
	2000 Professional	Intel [®] Pentium [®] 133 MHz	64 MB	128 MB	50 MB
	Me	Intel [®] Pentium [®] 150 MHz	32 MB	64 MB	50 MB
	XP Home Edition	Intel [®] Pentium [®] 300 MHz	128 MB	128 MB	50 MB
	XP Professional				
	XP Professional x64 Edition ²	AMD Opteron [™] AMD Athlon [™] 64 Intel [®] Xeon [™] with Intel [®] EM64T Intel [®] Pentium [®] 4 with Intel [®] EM64T	256 MB	256 MB	50 MB
Apple [®] Macintosh [®] ³	OS [®] 9.1 - 9.2 ⁴	All base models meet minimum requirements	32 MB	64 MB	50 MB
	OS [®] X 10.2.4 or greater		128 MB	160 MB	

¹ USB is not supported under Windows[®] 95 or Windows NT[®] 4.0.

² Download the printer driver for Windows[®] XP Professional x64 Edition from <http://solutions.brother.com>.

³ Power Macintosh with an Apple original pre-installed USB port.

⁴ Wireless network is not supported under Windows[®] 95 or Mac OS[®] 9.X.

Important information for choosing your paper

This section gives information to help you choose paper to use with this printer.



Note

If you use paper that is not recommended, a paper jam or misfeed may occur in the printer. See *Recommended paper* on page 7.

Before you buy a large quantity of paper

Make sure that the paper is suitable for the printer.

Paper for plain paper copies

Paper is divided by usage, such as paper for printing and paper for copying. The usage is usually written on the paper's package. Check the package to see whether it is suitable for laser printers. Use paper that is suitable for laser printers.

Basis weight

The basis weight of the paper in general use varies in different countries. We recommend that you use paper that weighs 75 to 90 g/m² (20 to 24 lb), although this printer is able to cope with thinner or thicker paper than these weights.

Unit	Europe	USA
g/m ²	80 to 90	75 to 90
lb		20 to 24

Long grain and short grain

The pulp fiber of the paper is aligned during paper manufacturing. And paper can be classified into two types, long grain and short grain.

Long grain paper's fiber direction is parallel to the carriage direction of the paper in the printer. Short grain paper's fiber direction is vertical to the carriage direction of the paper in the printer. Though most plain paper for copying is long grain, some is short grain. We recommend that you use long grain paper for this printer. Short grain paper is too weak for the paper carriage of the printer.

Acid paper and neutralized paper

Paper can be classified as either acid paper or neutralized paper.

Though modern paper manufacture methods started with acid paper, neutralized paper is recently taking the place of acid paper because of environmental issues.

However, many forms of acid paper can be found in recycled paper. We recommend that you use neutralized paper for this printer.

You can use an acid paper check pen to distinguish acid paper from neutral paper.

Print surface

The characteristics of the face side and reverse side of a sheet of paper may vary a little.

Usually, the opening side of the ream of the paper package is the print side. Follow the indications on the paper package. Typically, the print side is indicated by an arrow.

Moisture content

Moisture content is the amount of water left in the paper after manufacture. It is one of the important characteristics of the paper. This can change greatly depending on the storage environment, although usually paper contains about 5% water by weight. Because paper often absorbs water, the amount of water can sometimes be about 10% in a high humidity environment. When the amount of water increases, the characteristics of the paper changes greatly. The fixing of the toner may become worse. For storage of the paper and during use, we recommend that the humidity of the surrounding environment be between 50% and 60%.

Rough estimate of basis weight

g/m ²	lb	
	Bond	Index
60	16	
64	17	
75	20	
90	24	
105	28	
120	32	
135	36	
161	43	90
200	53	110

Paper size

Paper size	mm	in.
Letter		8.5 × 11 in.
Legal		8.5 × 14 in.
Executive		7.25 × 10.5 in.
A4	210 × 297 mm	
A5	148 × 210 mm	
A6	105 × 148 mm	
Envelope Monarch		3.875 × 7.5 in.
Envelope #9		3.875 × 8.9 in.
Envelope #10		4.12 × 9.5 in.
Envelope #11		4.5 × 10.375 in.
Envelope DL	110 × 220 mm	
Envelope C5	162 × 229 mm	
Envelope C6	114 × 162 mm	
B5 (JIS)	182 × 257 mm	
B5 (ISO)	176 × 250 mm	
B6	125 × 176 mm	
Folio		8.5 × 13 in.

Symbol and character sets

For the HP LaserJet, IBM Proprinter XL, and EPSON FX-850 emulation modes, you can choose the symbol and character sets using a web browser or the control panel buttons.

How to use the web browser

To use the web browser, follow the steps below.

- ① Enter [http://printer's IP address/] into your browser.
For example: [http://192.168.1.2/] (if the printer's IP address is 192.168.1.2)
- ② Click **Printer Settings**.
- ③ Enter a user name and a password. The default User Name is [admin] and the default Password is [access].
- ④ Click **OK**.
- ⑤ Choose the **HP LaserJet**, **IBM Proprinter XL** or **EPSON FX-850** tab and click **Font Setup**. Choose a symbol set you want to use from the **Symbol Set** list box.

Symbol and character sets list

OCR symbol sets

When you choose the OCR-A or OCR-B font, the matching symbol set is always used.

OCR A (00)

OCR B (10)

HP LaserJet mode

ABICOMP Brazil / Portugal (13P)

Desktop (7J)

HP German (0G)

ISO Latin1 (0N)

ISO Latin5 (5N)

ISO2 IRV (2U)

ISO5 ASCII (0U)

ISO11 Swedish (0S)

ISO15 Italian (0I)

ISO17 Spanish (2S)

ISO25 French (0F)

ISO60 Norwegian1 (0D)

ISO69 French (1F)

ISO85 Spanish (6S)

ISO8859 / 15 Latin (9N)

Legal (1U)

MC Text (12J)

PC8 (10U)

PC8 D/N (11U)

PC8 Latin / Greek (12G)

PC8 Turkish (9T)

PC850 Multilingual (12U)

PC852 East Europe (17U)

PC855 Cyrillic (10R)

PC858 Multilingual Euro (13U)

PC861 Iceland (21U)

PC865 Nordic (25U)

PC869 Greece (11G)

Pi Font (15U)

PS Text (10J)

ABICOMP International (14P)

Greek8 (8G)

HP Spanish (1S)

ISO Latin2 (2N)

ISO Latin6 (6N)

ISO4 UK (1E)

ISO10 Swedish (3S)

ISO14 JIS ASCII (0K)

ISO16 Portuguese (4S)

ISO21 German (1G)

ISO57 Chinese (2K)

ISO61 Norwegian2 (1D)

ISO84 Portuguese (5S)

ISO8859 / 7 Latin / Greek (12N)

ISO8859 / 15 Latin / Cyrillic (10N)

Math-8 (8M)

MS Publishing (6J)

PC8 Bulgarian (13R)

PC8 Greek Alternate (437G) (14G)

PC8 PC Nova (27Q)

PC775 (26U)

PC851 Greece (10G)

PC853 Latin3 (Turkish) (18U)

PC857 Latin5 (Turkish) (16U)

PC860 Portugal (20U)

PC863 Canadian French (23U)

PC866 Cyrillic (3R)

PC1004 (9J)

PS Math (5M)

Roman8 (8U)

HP LaserJet mode (Continued)

Roman9 (4U)	Roman Extension (0E)
Russian-GOST (12R)	Symbol (19M)
Turkish8 (8T)	Ukrainian (14R)
Ventura Math (6M)	Ventura Intl (13J)
Ventura US (14J)	Windows 3.0 (9U)
Windows Baltic (19L)	Windows Cyrillic (9R)
Windows Greek (9G)	Windows Latin1 (19U)
Windows Latin2 (9E)	Windows Latin5 (5T)
Wingdings (579L)	

IBM mode

PC8	PC8 D/N
PC8 Turkish	PC850 Multilingual
PC852 East Europe	PC860 Portugal
PC863 Canadian French	PC865 Nordic

Epson mode

Danish I	Danish II
Dutch	French I
French II	German
Italian	Norwegian
Japanese	PC8
PC8 D/N	PC8 Turkish
PC850 Multilingual	PC852 East Europe
PC860 Portugal	PC863 Canadian French
PC865 Nordic	South African
Spanish	Swedish
UK ASCII I	UK ASCII II
US ASCII	

Quick reference for bar code control commands

The printer can print bar codes in the HP LaserJet, EPSON FX-850, and IBM Proprinter XL emulation modes.

Print bar codes or expanded characters

Code	ESC i
Dec	27 105
Hex	1B 69

Format: ESC i n ... n \

Creates bar codes or expanded characters according to the segment of parameters 'n ... n'. For more information about parameters, see the following Definition of Parameters. This command must end with the '\ ' code (5CH).

Definition of Parameters

This bar code command can have the following parameters in the parameter segment (n ... n). As parameters are effective within the single command syntax ESC i n ... n \, they do not apply in the bar code commands. If certain parameters are not given, they take the preset settings. The last parameter must be the bar code data start ('b' or 'B') or the expanded character data start ('l' or 'L'). Other parameters can be given in any sequence. Each parameter can start with a lower-case or upper-case character, for example, 't0' or 'T0', 's3' or 'S3' and so on.

Bar code mode

n = 't0' or 'T0'	CODE 39 (default)
n = 't1' or 'T1'	Interleaved 2 of 5
n = 't3' or 'T3'	FIM (US-Post Net)
n = 't4' or 'T4'	Post Net (US-Post Net)
n = 't5' or 'T5'	EAN 8, EAN 13, or UPC A
n = 't6' or 'T6'	UPC E
n = 't9' or 'T9'	Codabar
n = 't12' or 'T12'	Code 128 set A
n = 't13' or 'T13'	Code 128 set B
n = 't14' or 'T14'	Code 128 set C
n = 't130' or 'T130'	ISBN (EAN)
n = 't131' or 'T131'	ISBN (UPC-E)
n = 't132' or 'T132'	EAN 128 set A
n = 't133' or 'T133'	EAN 128 set B
n = 't134' or 'T134'	EAN 128 set C

This parameter selects the bar code mode as shown above. When n is 't5' or 'T5' the bar code mode (EAN 8, EAN 13, or UPC A) varies according to the number of characters in the data.

Bar Code, expanded character, line block drawing and box drawing

n = 's0' or 'S0'	3: 1 (default)
n = 's1' or 'S1'	2: 1
n = 's3' or 'S3'	2.5: 1

This parameter chooses the bar code style as above. When the EAN 8, EAN 13, UPC-A, Code 128 or EAN 128 bar code mode is chosen, this bar code style parameter is ignored.

Expanded Character

'S'

0 = White

1 = Black

2 = Vertical stripes

3 = Horizontal stripes

4 = Cross hatch

For example 'S' n1 n2

n1 = Background fill pattern

n2 = Foreground fill pattern

If 'S' is followed by only one parameter, the parameter is a foreground fill pattern.

Line block drawing & box drawing

'S'

1 = Black

2 = Vertical stripes

3 = Horizontal stripes

4 = Cross hatch

Bar Code

n = 'mnnn' or 'Mnnn' (nnn = 0 ~ 32767)

This parameter shows the bar code width. The unit of 'nnn' is a percentage.

Bar code human readable line ON or OFF

n = 'r0' or 'R0' Human readable line OFF
 n = 'r1' or 'R1' Human readable line ON

Preset: Human readable line ON
 (1) 'T5' or 't5'
 (2) 'T6' or 't6'
 (3) 'T130' or 't130'
 (4) 'T131' or 't131'

Preset: Human readable line OFF
 All others

This parameter shows whether the printer prints the human readable line below the bar code. Human readable characters are always printed with OCR-B font of 10 pitch and all the current character style enhancements are masked. The default setting is determined by the bar code mode selected by 't' or 'T'.

Quiet zone

n = 'onnn' or 'Onnn' (nnn = 0 ~ 32767)

Quiet zone is the space on both sides of the bar codes. Its width can be shown using the units that are set by the 'u' of 'U' parameter. (For the description of 'u' or 'U' parameter, see the next section.) The default setting of the quiet-zone width is 1 inch.

Bar code, expanded character unit, line block drawing and box drawing

n = 'u0' or 'U0' mm (preset)
 n = 'u1' or 'U1' 1/10
 n = 'u2' or 'U2' 1/100
 n = 'u3' or 'U3' 1/12
 n = 'u4' or 'U4' 1/120
 n = 'u5' or 'U5' 1/10 mm
 n = 'u6' or 'U6' 1/300
 n = 'u7' or 'U7' 1/720

This parameter shows the measurement units of X-axis offset, Y-axis offset, and bar code height.

Bar code, expanded character, line block drawing and box drawing offset in X-axis

n = 'xnnn' or 'Xnnn'

This parameter shows the offset from the left margin in the 'u'- or 'U'-specified unit.

Bar code & expanded character offset in Y-axis

n = 'ynnn' or 'Ynnn'

This parameter shows the downward offset from the current print position in the 'u'- or 'U'-specified unit.

Bar code, expanded character, line block drawing and box drawing height

n = 'hnnn', 'Hnnn', 'dnnn', or 'Dnnn'

1 EAN13, EAN8, UPC-A, ISBN (EAN13, EAN8, UPC-A), ISBN (UPC-E): 22 mm

2 UPC-E: 18 mm

3 Others: 12 mm

Expanded characters → 2.2 mm (preset)

Line block drawing and box drawing → 1 dot

This parameter shows the height of bar codes or expanded characters as shown above. It can start with 'h', 'H', 'd', or 'D'. The height of bar codes is shown in the 'u'- or 'U'-specified unit. The default setting of the bar code height (12 mm, 18 mm or 22 mm) is determined by the bar code mode selected by 't' or 'T'.

Expanded character width, line block drawing and box drawing

n = 'wnnn' or 'Wnnn'

Expanded character → 1.2 mm

Line block drawing and box drawing → 1 dot

This parameter shows the width of expanded characters as shown above.

Expanded character rotation

n = 'a0' or 'A0' 'Upright (preset)

n = 'a1' or 'A1' 'Rotated 90 degrees

n = 'a2' or 'A2' 'Upside down, rotated 180 degrees

n = 'a3' or 'A3' 'Rotated 270 degrees

Bar code data start

n = 'b' or 'B'

Data that follows 'b' or 'B' is read in as bar code data. Bar code data must end with the '\ ' code (5CH), which also ends this command. The acceptable bar code data is determined by the bar code mode selected by 't' or 'T'.

■ When CODE 39 is chosen with the parameter 't0' or 'T0'

Forty three characters '0' to '9', 'A' to 'Z', '-', '.', ' (space)', '\$', '/', '+', and '%' can be accepted as bar code data. Other characters will cause a data error. The number of characters for bar codes is not limited. The bar code data automatically starts and ends with an asterisk '*' (start character and stop character). If the received data has an asterisk '*' at the beginning or end, the asterisk is regarded as a start character or stop character.

■ When Interleaved 2 of 5 is selected with the parameter 't1' or 'T1':

Ten numerical characters '0' to '9' can be accepted as bar code data. Other characters cause a data error. The number of characters for bar codes is not limited. This mode of bar codes needs even characters. If the bar code data has odd characters, '0' is automatically added to the end of the bar code data.

- When FIM (US-Post Net) is selected with the parameter 't3' or 'T3'
 Characters 'A' to 'D' are valid and one digit of data can be printed. Upper-case and lower-case alphabet characters can be accepted.
 - When Post Net (US-Post Net) is selected with the parameter 't4' or 'T4'
 Numbers '0' to '9' can be data and it must end with a check digit. '?' can be used instead of the check digit.
 - When EAN 8, EAN 13, or UPC A is selected with the parameter 't5' or 'T5'
 Ten numbers '0' to '9' can be accepted as bar code data. The number of characters for bar codes is limited as follows:
 EAN 8: Total 8 digits (7 digits + 1 check digit)
 EAN 13: Total 13 digits (12 digits + 1 check digit)
 UPC A: Total 12 digits (11 digits + 1 check digit)
 A number of characters other than those stated above will cause a data error that results in the bar code data being printed as normal print data. If the check digit is not correct, the printer decides the correct check digit automatically so that the correct bar code data will be printed. When EAN13 is selected, adding '+' and a two-digit or five-digit number after the data can create an add-on code.
 - When UPC-E is selected with the parameter 't6' or 'T6':
 The numbers '0' to '9' can be accepted as bar code data.
- Eight digits^{1 2} (standard format) The first character must be '0' and the data must end with a check digit.
 Total eight digits = '0' plus 6 digits plus 1 check digit.
- Six digits² The first character and the last check digit are removed from the eight digit data.
- ¹ '?' can be used instead of a check digit.
² Adding '+' and two-digit or five-digit number after the data creates an add-on code.
- When Codebar is chosen with the parameter 't9' or 'T9'
 Characters '0' to '9', '-', '.', '\$', '/', '+', ':' can be printed. Characters 'A' to 'D' can be printed as a start-stop code, which can be upper case or lower case. If there is no start-stop code, errors will happen. A check digit cannot be added and using '?' causes errors.
 - When Code 128 Set A, Set B, or Set C is selected with the parameter 't12' or 'T12', 't13' or 'T13', or 't14' or 'T14'
 Code 128 sets A, B and C can be individually selected. Set A shows characters Hex 00 to 5F. Set B includes characters Hex 20 to 7F. Set C includes the pairs 00 to 99. Switching is allowed between the code sets by sending %A, %B, or %C. FNC 1, 2, 3, and 4 are produced with %1, %2, %3, and %4. The SHIFT code, %S, allows temporary switching (for one character only) from set A to set B and vice versa. The '%' character can be encoded by sending it twice.
 - When ISBN (EAN) is selected with the parameter 't130' or 'T130'
 The same rules apply as for 't5' or 'T5'.
 - When ISBN (UPC-E) is selected with the parameter 't131' or 'T131':
 The same rules apply as for 't6' or 'T6'.

- When EAN 128 set A, set B or set C is selected with the parameter 't132' or 'T132', 't133' or 'T133' or 't134' or 'T134'

The same rules apply as for 't12' or 'T12', 't13' or 'T13', or 't14' or 'T14'.

Box drawing

ESC i ... E (or e)

'E' or 'e' is a terminator.

Line block drawing

ESC i ... V (or v)

'V' or 'v' is a terminator.

Expanded character data start

n = 'I' or 'L'

Data that follows 'I' or 'L' is read as expanded character data (or labeling data). Expanded character data must end with the '\ ' code (5CH), which also ends this command.

Example Program Listings

```
WIDTH "LPT1:",255
'CODE 39
LPRINT CHR$(27);"it0r1s0o0x00y00bCODE39?\";
'Interleaved 2 of 5
LPRINT CHR$(27);"it1r1s0o0x00y20b123456?\";
'FIM
LPRINT CHR$(27);"it3r1o0x00y40bA\";
'Post Net
LPRINT CHR$(27);"it4r1o0x00y60b1234567890?\";
'EAN-8
LPRINT CHR$(27);"it5r1o0x00y70b1234567?\";
'UPC-A
LPRINT CHR$(27);"it5r1o0x50y70b12345678901?\";
'EAN-13
LPRINT CHR$(27);"it5r1o0x100y70b123456789012?\";
'UPC-E
LPRINT CHR$(27);"it6r1o0x150y70b0123456?\";
'Codabar
LPRINT CHR$(27);"it9r1s0o0x00y100bA123456A\";
'Code 128 set A
LPRINT CHR$(27);"it12r1o0x00y120bCODE128A12345?\";
```

```
'Code 128 set B
LPRINT CHR$(27);"it13r1o0x00y140bCODE128B12345?\\";
'Code 128 set C
LPRINT CHR$(27);"it14r1o0x00y160b";CHR$(1);CHR$(2);"?\\";
'ISBN(EAN)
LPRINTCHR$(27);"it130r1o0x00y180b123456789012?+12345\\";
'EAN 128 set A
LPRINT CHR$(27);"it132r1o0x00y210b1234567890?\\";
LPRINT CHR$(12)
END
```

B

Appendix (For Europe and Other Countries)

Brother Numbers

IMPORTANT

For technical and operational help, you must call the country where you bought the printer. Calls must be made *from within* that country.

Register your product

By registering your Brother product, you will be recorded as the original owner of the product.

Your registration with Brother:

- may serve as a confirmation of the purchase date of your product should you lose your receipt;
- may support an insurance claim by you in the event of product loss covered by insurance; and,
- will help us to notify you of enhancements to your product and special offers.

Please complete the Brother Warranty Registration or, for your convenience and most efficient way to register your new product, register on-line at

<http://www.brother.com/registration/>

Frequently asked questions (FAQs)

The Brother Solutions Center is our one-stop resource for all your printer needs. You can download the latest drivers, software and utilities, read FAQs and troubleshooting tips to learn how to get the most from your Brother product.

<http://solutions.brother.com>

You can check here for Brother driver updates.

Customer Service

Visit <http://www.brother.com> for contact information on your local Brother office.

Service center locations

For service centres in Europe, contact your local Brother Office. Address and telephone contact information for European offices can be found at <http://www.brother.com> by selecting your country.

Internet Addresses

Brother Global Web Site: <http://www.brother.com>

For Frequently Asked Questions (FAQs), Product Support and Technical Questions, and Driver Updates and Utilities: <http://solutions.brother.com>

Important information: Regulations

Radio interference (220 to 240 volt model only)

This printer follows EN55022 (CISPR Publication 22)/Class B.

Before you use this product, make sure that you use one of the following interface cables.

- 1 A shielded parallel interface cable with twisted-pair conductors and that it is marked IEEE 1284 compliant.
- 2 A USB cable.

The cable must not be more than 2 meters long.

IEC 60825-1 specification (220 to 240 volt model only)

This printer is a Class 1 laser product as defined in IEC 60825-1 specifications. The label shown below is attached in countries where it is needed.



This printer has a Class 3B laser diode which produces invisible laser radiation in the laser unit. You should not open the laser unit under any circumstances.

Caution

Use of controls or adjustments or performance of procedures other than those specified in this User's Guide may result in hazardous radiation exposure.

For Finland and Sweden

LUOKAN 1 LASERLAITE

KLASS 1 LASER APPARAT

Varoitus!

Laitteen käyttäminen muulla kuin tässä käyttöohjeessa mainitulla tavalla saattaa altistaa käyttäjän turvallisuusluokan 1 ylittävälle näkymättömälle lasersäteilylle.

Varning

Om apparaten används på annat sätt än i denna Bruksanvisning specificerats, kan användaren utsättas för osynlig laserstrålning, som överskrider gränsen för laserklass 1.

Internal laser radiation

Maximum radiation power: 5 mW
Wave length: 770 - 810 nm
Laser class: Class 3B

IMPORTANT - For Your Safety

To ensure safe operation, the supplied three-pin plug must be inserted only into a standard three-pin power outlet that is properly grounded through the standard electrical wiring.

Extension cords used with this printer must be three-pin plug type and correctly wired to provide proper grounding. Incorrectly wired extension cords may cause personal injury and equipment damage.

The fact that the equipment operates satisfactorily does not imply that the power is grounded and that the installation is completely safe. For your safety, if in any doubt about the effective grounding of the power, call a qualified electrician.

This product should be connected to an AC power source within the range indicated on the rating label. DO NOT connect it to a DC power source. If you are not sure, contact a qualified electrician.

Disconnect device

You must install this printer near a power outlet that is easily accessible. In case of an emergency, you must disconnect the power cord from the power outlet to shut off the power completely.

Caution for LAN connection

Connect this product to a LAN connection that is not subjected to overvoltages.

IT power system (For Norway only)

This product is also designed for an IT power system with phase-to-phase voltage 230V.

Wiring information (for UK)

Important

If you need to replace the plug fuse, fit a fuse that is approved by ASTA to BS1362 with the same rating as the original fuse.

Always replace the fuse cover. Never use a plug that does not have a cover.

Warning - This printer must be earthed.

The wires in the mains lead are coloured in line with the following code:

■ **Green and Yellow: Earth**

■ **Blue: Neutral**

■ **Brown: Live**

If in any doubt, call a qualified electrician.

EC Declaration of Conformity



EC Declaration of Conformity

Manufacturer

Brother Industries, Ltd.
15-1, Naeshiro-cho, Mizuho-ku, Nagoya 467-8561, Japan

Plant

Brother Corporation (Asia) Ltd. Brother Buji Nan Ling Factory
Gold Garden Ind., Nan Ling Village, Buji, Rong Gang, Shenzhen, China

Herewith declare that:

Product description : Laser Printer

Model Name : HL-5270DN

are in conformity with provisions of the Directives applied : Low Voltage Directive 73/23/EEC (as amended by 93/68/EEC) and the Electromagnetic Compatibility Directive 89/336/EEC (as amended by 91/263/EEC and 92/31/EEC and 93/68/EEC).

Product description : Laser Printer

Model Name : HL-5280DW

is in conformity with provisions of the R & TTE Directive (1999/5/EC) and we declare compliance with the following standards :

Standards applied :

Harmonized :

Safety	EN60950-1:2001
EMC	EN55022: 1998 +A1: 2000 +A2: 2003 Class B EN55024: 1998 +A1: 2001 +A2: 2003 EN61000-3-2: 2000 EN61000-3-3: 1995 +A1: 2001
Radio	EN301 489-1 V1.4.1 EN301 489-17 V1.2.1 EN300 328 V1.6.1

※ Radio applies to HL-5280DW only.

Year in which CE marking was First affixed : 2005

Issued by : Brother Industries, Ltd.

Date : 28th December, 2005

Place : Nagoya, Japan

Signature :

Takashi Maeda
Manager
Quality Management Group
Quality Management Dept.
Information & Document Company

Brother Numbers

IMPORTANT

For technical and operational help, you must call the country where you bought the printer. Calls must be made **from within** that country.

Register your product

By registering your product with Brother International Corporation, you will be recorded as the original owner of the product.

Your registration with Brother:

- may serve as a confirmation of the purchase date of your product should you lose your receipt;
- may support an insurance claim by you in the event of product loss covered by insurance; and,
- will help us notify you of enhancements to your product and special offers.

Please complete the Brother Warranty Registration or, for your convenience and most efficient way to register your new product, register on-line at

<http://www.brother.com/registration/>

FAQs (Frequently asked questions)

The Brother Solutions Center is our one-stop resource for all your printer needs. You can download the latest software and utilities and read FAQs and troubleshooting tips to learn how to get the most from your Brother product.

<http://solutions.brother.com>

You can check here for Brother driver updates.

Customer Service**In USA:** 1-800-276-7746**In Canada:** 1-877-BROTHER

If you have comments or suggestions, please write us at:

In USA: Printer Customer Support
Brother International Corporation
15 Musick Irvine, CA 92618**In Canada:** Brother International Corporation (Canada), Ltd.
- Marketing Dept.
1, rue Hotel de Ville Dollard-des-Ormeaux, PQ, Canada H9B 3H6**Service center locator (USA only)**

For the location of a Brother authorized service center, call 1-800-284-4357.

Service center locations (Canada only)

For the location of a Brother authorized service center, call 1-877-BROTHER

Internet AddressesBrother Global Web Site: <http://www.brother.com>For Frequently Asked Questions (FAQs), Product Support and Technical Questions, and Driver Updates and Utilities:
<http://solutions.brother.com>(In USA Only) For Brother Accessories & Supplies: <http://www.brothermall.com>**Ordering supplies**

For best quality results use only genuine Brother supplies, which are available at most Brother retailers. If you cannot find the supplies you need and you have a Visa, MasterCard, Discover, or American Express credit card, you can order supplies directly from Brother. (In the USA, you can visit us online for a complete selection of the Brother accessories and supplies that are available for purchase.)

In USA: 1-888-879-3232 (voice)
1-800-947-1445 (fax)
<http://www.brothermall.com>**In Canada:** 1-877-BROTHER (voice)

Description	Item
Toner Cartridge	TN-550 (Standard, prints approx. 3, 500 pages) TN-580 (High Yield, prints approx. 7,000 pages)
Drum Unit	DR-520

Important information: Regulations

Federal Communications Commission (FCC) Declaration of Conformity (For USA)

Responsible Party: Brother International Corporation
100 Somerset Corporate Boulevard
P.O. Box 6911
Bridgewater, NJ 08807-0911
USA
Telephone: (908) 704-1700

declares, that the products

Product name: Laser Printer HL-5280DW
Model number: HL-52
Product option: Lower Tray Unit LT-5300

complies with Part 15 of the FCC Rules. Operation is subject to the following two conditions: (1) This device may not cause harmful interference, and (2) this device must accept any interference received, including interference that may cause undesired operation.

This equipment has been tested and found to comply with the limits for a Class B digital device, pursuant to Part 15 of the FCC Rules. These limits are designed to provide reasonable protection against harmful interference in a residential installation. This equipment generates, uses, and can radiate radio frequency energy and, if not installed and used in accordance with the instructions, may cause harmful interference to radio communications. However, there is no guarantee that interference will not occur in a particular installation. If this equipment does cause harmful interference to radio or television reception, which can be determined by turning the equipment off and on, the user is encouraged to try to correct the interference by one or more of the following measures:

- Reorient or relocate the receiving antenna.
- Increase the separation between the equipment and receiver.
- Connect the equipment into an outlet on a circuit different from that to which the receiver is connected.
- Consult the dealer or an experienced radio/TV technician for help.

Important

A shielded interface cable should be used to ensure compliance with the limits for a Class B digital device. Changes or modifications not expressly approved by Brother Industries, Ltd. could void the user's authority to operate the equipment.

Industry Canada Compliance Statement (For Canada)

This Class B digital apparatus complies with Canadian ICES-003.

Cet appareil numérique de la classe B est conforme à la norme NMB-003 du Canada.

Laser Notices

Laser Safety (110 to 120 volt model only)

This printer is certified as a Class 1 laser product under the U.S. Department of Health and Human Services (DHHS) Radiation Performance Standard according to the Radiation Control for Health and Safety Act of 1968. This means that the printer does not produce hazardous laser radiation.

Since radiation emitted inside the printer is completely confined within protective housings and external covers, the laser beam cannot escape from the machine during any phase of user operation.

FDA Regulations (110 to 120 volt model only)

The U.S. Food and Drug Administration (FDA) has implemented regulations for laser products manufactured on and after August 2, 1976. Compliance is mandatory for products marketed in the United States. One of the following labels on the back of the printer indicates compliance with the FDA regulations and must be attached to laser products marketed in the United States.

MANUFACTURED:

Brother Industries, Ltd.,

15-1 Naeshiro-cho Mizuho-ku Nagoya, 467-8561 Japan

This product complies with FDA performance standards for laser products except for deviations pursuant to Laser Notice No.50, dated July 26, 2001.

MANUFACTURED:

Brother Corporation (Asia) Ltd. Brother Buji Nan Ling Factory

Gold Garden Ind., Nan Ling Village, Buji, Rong Gang, Shenzhen, CHINA

This product complies with FDA performance standards for laser products except for deviations pursuant to Laser Notice No.50, dated July 26, 2001.

Caution

Use of controls, adjustments or performance of procedures other than those specified in this User's Guide may result in hazardous radiation exposure.

Internal laser radiation

Maximum radiation power: 5 mW

Wave length: 770 - 810 nm

Laser class: Class 3B

IMPORTANT - For Your Safety

To ensure safe operation, the supplied three-pin plug must be inserted only into a standard three-pin power outlet that is properly grounded through the standard electrical wiring.

Extension cords used with this printer must be three-pin plug type and correctly wired to provide proper grounding. Incorrectly wired extension cords may cause personal injury and equipment damage.

The fact that the equipment operates satisfactorily does not imply that the power is grounded and that the installation is completely safe. For your safety, if in any doubt about the effective grounding of the power, call a qualified electrician.

This product should be connected to an AC power source within the range indicated on the rating label. DO NOT connect it to a DC power source. If you are not sure, contact a qualified electrician.

Disconnect device

You must install this printer near a power outlet that is easily accessible. In case of an emergency, you must disconnect the AC power cord from the AC power outlet to shut off the power completely.

Caution for LAN connection

Connect this product to a LAN connection that is not subjected to overvoltages.

D

Index

Symbols

+ or - buttons 49

A

Accessories tab 34
Advanced tab 29
Automatic duplex printing 22
Automatic Emulation Selection 45
Automatic Interface Selection 46

B

Back button 49
Back light 50
Back view 3
Bar code control 125
Basic tab 28
Booklet printing 24
BRAdmin Light 44
BRAdmin Professional 44
Brother Numbers (USA/Canada) 137, 138
BR-Script 3 113
BR-Script 3 mode 45
BR-Script menu 62
BR-Script printer driver 36
Buttons 48

C

Call Service messages 93
Carbon copy printing 25
Carton contents 1
Character sets 122
Cleaning 85
Consumables 74
Control panel 47, 116
Corona wire 78, 89, 90

D

Data lamp 50
Default settings 56
Delete storage 58
Device options 31
Dimensions 117
Dimm 70
DOS 112
Driver Deployment Wizard 44
Drum unit 80, 117

Duplex printing 20

E

Emulation 115
Emulation modes 45
Envelopes 8, 16
EPSON FX-850 mode 45
Error messages 92, 94

F

Fonts 115
Front view 2

G

Go button 48

H

HP LaserJet mode 45

I

INFORMATION menu 56
Interface 115
INTERFACE menu 66

J

Jam in duplex unit 104
Jam in MP tray 97
Jam inside printer 99
Jam rear 101
Job Cancel button 48

L

LCD (liquid crystal display) 50
LCD menu 56
LED (light emitting diode) 50
Linux 26
Lower tray unit 69

M

Macintosh® 39, 112
Maintenance messages 93
Maintenance parts 84
Manual duplex printing 20

Media specifications	117
Media type	6
Memory	70, 115
Multi-purpose tray	13, 16, 21

N

Network	44
Network connectivity	115
Network default setting	68
NETWORK menu	63, 64
Network Print Software	44

O

OPC drum	107
Options	69

P

Paper	6, 119
Paper handling	116
Paper jams	96
PAPER menu	57
Parallel interface	46
Plain paper	7
Power	4
Power supply	4
PRINT menu	58
Print quality	105
Printable area	9
Printer driver	28, 36, 42, 116
Processor	115
Proprinter XL mode	45

Q

QUALITY menu	57
--------------------	----

R

Register your product	132, 137
Reprint	32, 52
Reprint button	48, 49
RESET menu	66

S

Scanner window	88
Secure data	53
Service centers (USA/Canada)	138
Service centres (Europe and other countries)	132
SETUP menu	57

Software	44
Specifications	114
Support tab	35
Symbol	122
System requirements	118

T

TCP/IP	63, 64
Toner cartridge	74, 117

U

USB interface	46
Utilities	116

W

Web BRAdmin	44
Weights	117
WLAN	64