

# GENIE<sup>®</sup> PRO

## STEALTH / MAX<sup>™</sup>

**GPS-IC Series**  
**PMX-IC B Series**

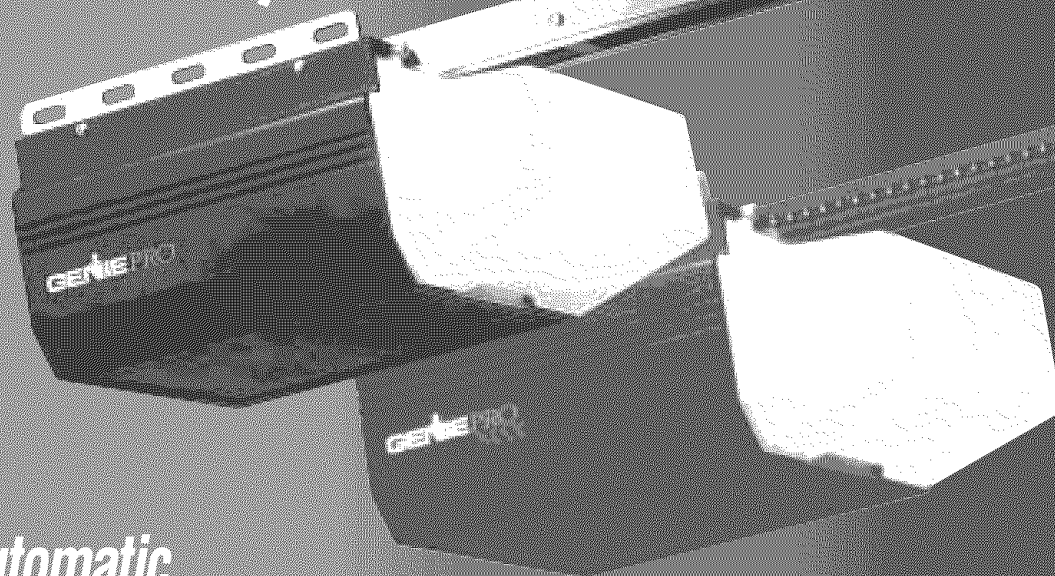

*Automatic*  
**Chain Drive/Belt Drive**  
**Garage Door Operator**  
**System**

**Complete with INTELICODE<sup>™</sup> Remote Control**  
**and SERIES II Electronics**

Operator **MUST** be installed with the included SERIES II Wall Control!

Self-diagnostic Electronic Sensory Protection System  
(SAFE-T-BEAM SYSTEM) **MUST** Be Installed To Close Door!

### Owner's Manual

SAVE FOR FUTURE REFERENCE

### Customer Service

CALL: 1-800-354-3643

VISIT: WWW.GENIECOMPANY.com

**AUTOMATIC GARAGE DOOR OPERATOR SYSTEMS**  
**HANG MANUAL NEAR YOUR WALL CONTROL**

### TABLE OF CONTENTS

SECTION	PAGE
SAFETY INFORMATION .....	2-4
PARTS IDENTIFICATION .....	5-6
ASSEMBLY	
1 OPERATOR ASSEMBLY .....	10-11
1A Channel and Power Head Assembly .....	10
1B Rail and Power Head Assembly .....	10-11
INSTALLATION	
2 DETERMINE DOOR TYPE AND MOUNTING METHOD ...	11
2A Installation on Track Guided Doors .....	12-14
2B Installation on Trackless Doors .....	15-17
3 SAFE-T-BEAM <sup>®</sup> (STB) SYSTEM INSTALLATION .....	18-19
Self-diagnostic "STB" System Troubleshooting .....	19
4 WALL CONTROL INSTALLATION .....	20
5 CONNECT OPERATOR TO POWER .....	21
6 MAIN LIMIT SWITCH SETTINGS .....	22
OPERATION	
7 FORCE ADJUSTMENT .....	23
Contact Reverse .....	23
8 FINE LIMIT SWITCH ADJUSTMENTS .....	24
9 REMOTE CONTROLS .....	24-25
10 BATTERY & VISOR CLIP INSTALLATION .....	25
11 LIGHT BULB AND LENS INSTALLATION .....	26
MAINTENANCE .....	27
TROUBLESHOOTING GUIDE .....	28
WIRING DIAGRAM .....	29
ACCESSORIES .....	30
WARRANTY .....	32

## Things to consider if you are planning to “do-it-yourself.”

Whether you are replacing an existing garage door operator or installing an operator in your garage for the first time, there are some pre-installation issues which need to be addressed. They are as follows:

*The Genie Company recommends that you read and fully understand all information and instructions contained herein before choosing a “Do-It-Yourself” installation. Any questions should be directed to the Genie Company or an authorized Genie Dealer.*

*(The issue numbers below refer to the circled numbers in the illustrations on page 3.)*

- ① Check your ceiling where the power head of your new unit will be mounted.** Plan how you will be mounting the power head. It is possible that ceiling joists may not be in the exact position needed with respect to the garage door operator. In any case, it may be necessary to add an additional bracket and fasteners (not included with your new door operator kit).
- ② Check the wall directly above the garage door.** The door operator’s header bracket must be securely fastened to this wall. Insure that the structure will provide a strong mounting location.
- ③ Check to see if the mounting location for the Safe-T-Beam® System (STB) is clear from obstruction and has a wood surface available for attaching the STB brackets.** The brackets may also be attached to concrete if necessary but extra tools and special fasteners (not supplied) will be required.  
**NOTE:** 1-1/2” “STB” bracket adapters are available through your local Genie Dealer.
- ④ Is your garage door made of light-weight steel, aluminum, fiberglass or glass panels?** Additional support bracing must be added to these type doors. If this is the case, please contact the door distributor or manufacturer so that they can furnish you with a “bracing kit.”
- ⑤ You need a 110-120 Volt power supply available.** If you plan to plug the unit into a standard electrical outlet, is one available? The outlet should be no more than about 3 feet from the power head once it is mounted. (The cord is 4 ft. in length.) SEE WARNING BELOW.
- ⑥ To avoid damage to your door and/or operator, make sure you disable any door locks prior to installing your operator.**
- ⑦ Insure that your door is properly balanced and moving freely.** SEE WARNING BELOW.
- ⑧ (NOT SHOWN) If your garage does not have a separate entry door,** you might want to consider an emergency release kit (GER-2) for installation on your garage door. See page 30.

### **⚠ WARNING**

**DO NOT USE EXTENSION CORD!**  
Extension cords can cause dangerous overheating conditions.  
**DO NOT USE PORTABLE GENERATOR!**  
This product is designed to operate on standard house current. Do not use alternate power supplies.

### **⚠ WARNING**

If your door sticks, binds, or is out of balance, have it adjusted by a professional. Door springs, cables, pulleys, brackets and associated hardware are under extreme tension and can cause serious injury or death.



TYPICAL SECTIONAL DOOR INSTALLATION

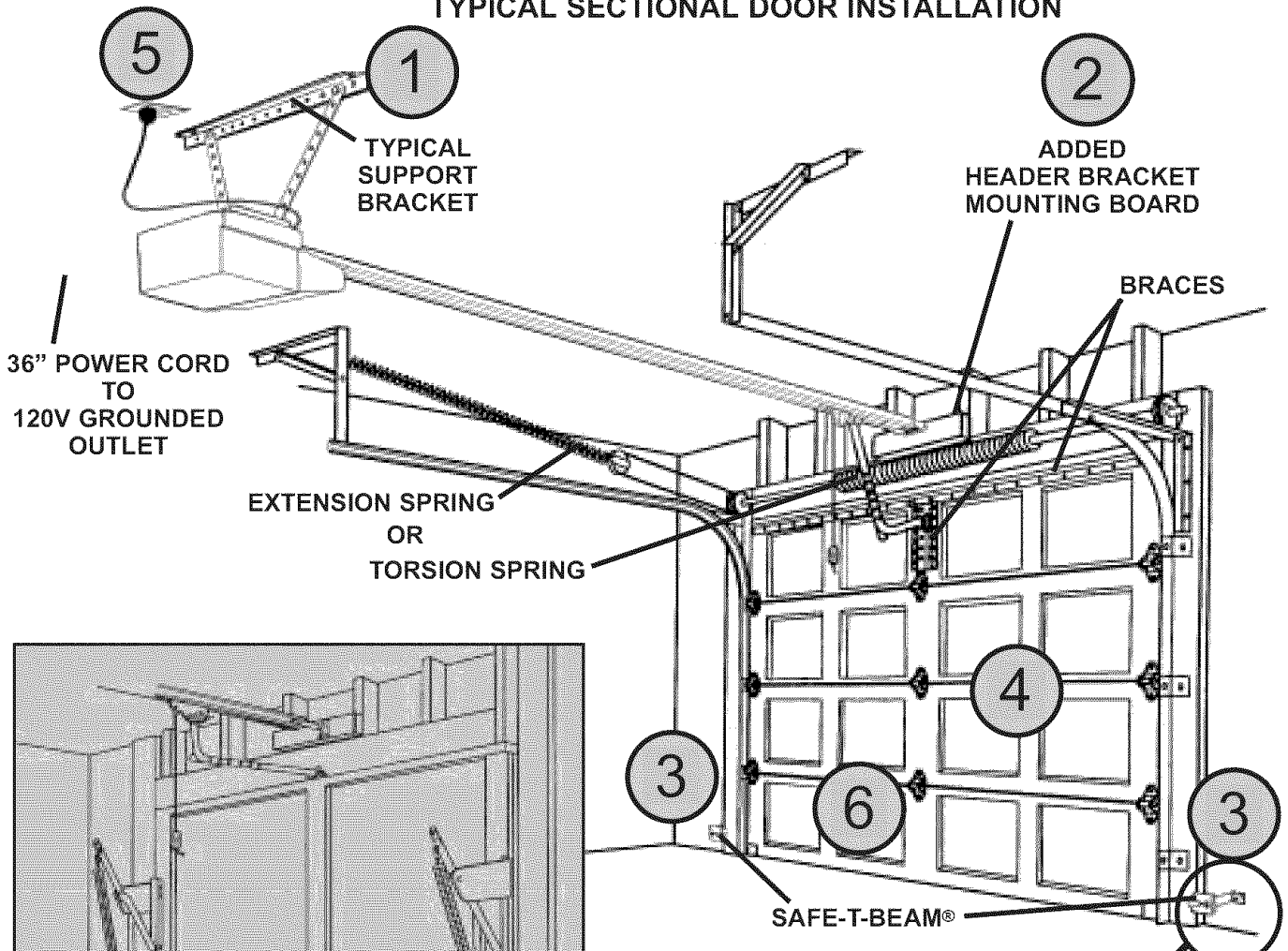

3

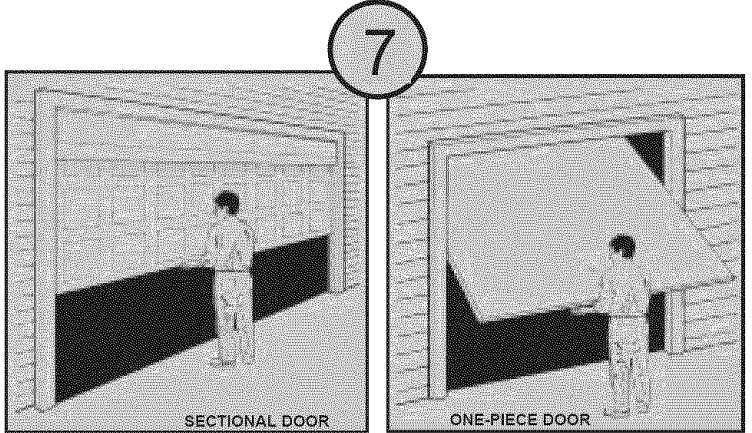
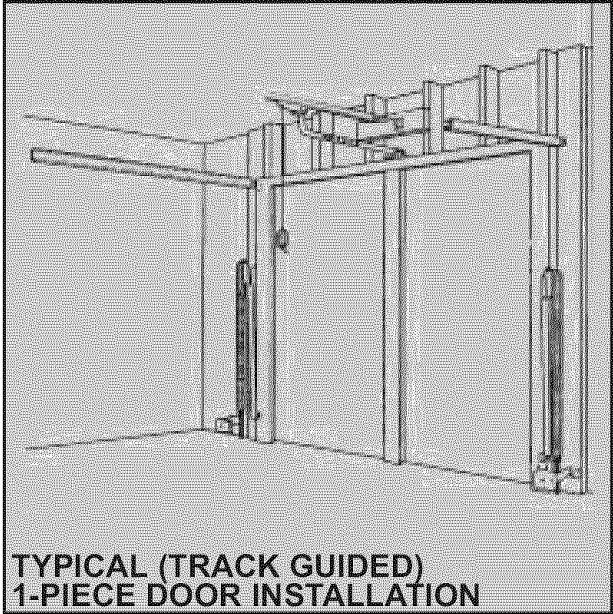
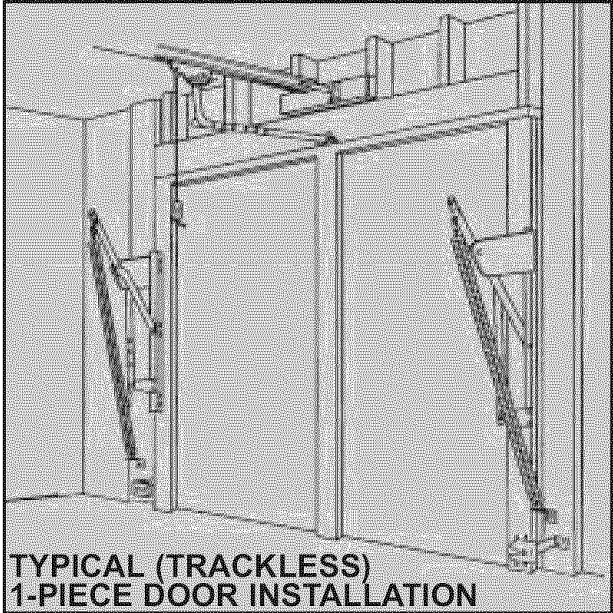
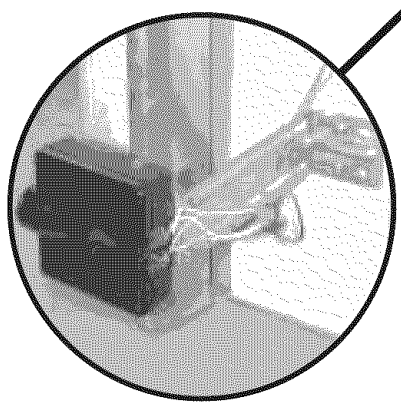

## OVERVIEW OF POTENTIAL HAZARDS

Garage doors are large, heavy objects that move with the help of springs under high tension and electric motors. Since moving objects, springs under tension, and electric motors can cause injuries, your safety and the safety of others depend on you reading the information in this manual. If you have questions or do not understand the information presented, call your nearest service representative.

In this section and those that follow, the words **Danger**, **Warning**, and **Caution** are used to emphasize important safety information.



The word:

**▲ DANGER** means that severe injury or death will result from failure to follow instructions.

**▲ WARNING** means that severe injury or death can result from failure to follow instructions.

**▲ CAUTION** means that property damage or injury can result from failure to follow instruction.

The word **NOTE** is used to indicate important steps to be followed or important considerations.

POTENTIAL HAZARD	EFFECT	PREVENTION
 <b>MOVING DOOR</b>	<b>WARNING:</b> Can Cause Serious Injury or Death	Keep people clear of opening while door is moving. <b>Do Not</b> allow children to play with the door operator. <b>Do Not</b> operate a door that jams or one that has a broken spring.
 <b>ELECTRICAL SHOCK</b>	<b>WARNING:</b> Can Cause Serious Injury or Death	Turn off power before removing operator cover. When replacing cover, make sure wires are not pinched or near moving parts. Operator must be properly grounded.
 <b>HIGH SPRING TENSION</b>	<b>WARNING:</b> Can Cause Serious Injury or Death	<b>Do Not</b> try to remove, repair or adjust springs or anything to which door spring parts are fastened, such as, wood blocks, steel brackets, cables or other like items. Repairs and adjustments must be made by a trained service person using proper tools and instructions.

## IMPORTANT INSTALLATION INSTRUCTIONS

### **▲ WARNING:**

### To reduce the risk of severe injury or death:

1. READ AND FOLLOW ALL SAFETY, INSTALLATION AND OPERATION INSTRUCTIONS. If you have any questions or do not understand an instruction, call your service representative.
2. Do Not install operator on an improperly balanced door. An improperly balanced door could cause severe injury. Repairs and adjustments to cables, spring assembly, and other hardware must be made by a trained service person using proper tools and instructions.
3. Remove all ropes and disable all locks connected to the door before installing operator.
4. Install door operator 7 feet or more above the floor. Mount the emergency release knob 6 feet above the floor.
5. Do Not connect the operator to the source of power until instructed to do so.
6. Locate the control button:
  - Within sight of door.
  - At a minimum height of 5 feet, so small children cannot reach it.
  - Away from all moving parts of the door.
7. Install the entrapment WARNING label next to the wall button or console. Install the emergency release tag on, or next to, the emergency release.
8. The operator must reverse when the door contacts a 1-1/2 inch high object on the floor at the center of the doorway. This is about the size of a 2" x 4" board laid flat.

## SAFETY FEATURES (varies by model)

### Safe-T-Beam® (STB) Non-Contact Reversing System

Places an invisible beam across door opening that reverses the door during down travel to the fully open position if anything passes through beam.

### Safe-T-Reverse® Contact Reversing System

Automatically stops and reverses a closing door within 2 seconds of contact with an object.

### Safe-T-Stop® Timed Reversed System

Automatically opens a closing door, if door does not close within 30 seconds.

### Force Guard® Control

Used to set the force required for opening and closing door. For maximum safety, set the minimum force required to fully open and close door.

### Automatic Lighting System

One or two light bulbs (depending on model) up to 100 Watts max. each are used for safer entries and exits. The light turns on when door is activated and automatically turns off 4.5 minutes later.

### Manual Emergency Release





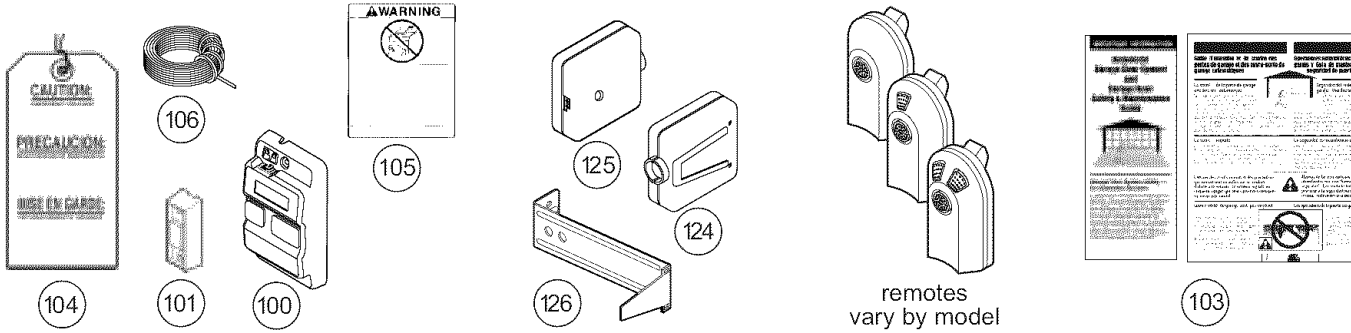

Allows the garage door to be opened or closed manually for emergencies or maintenance.



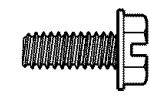
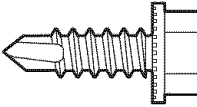

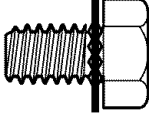
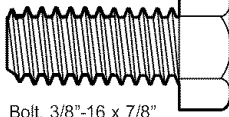
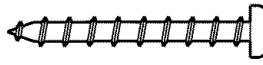
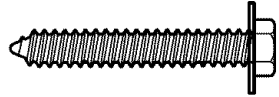
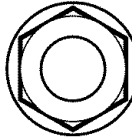
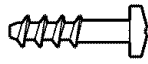
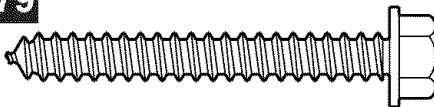
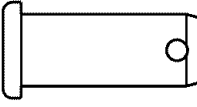
*NOTE: Accessories vary by model.*

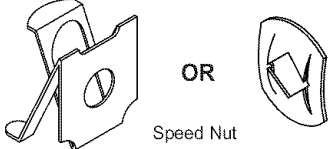
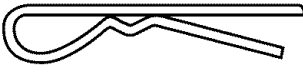
**FASTENERS - Shown full size. See Parts List for description.**

<p><b>69</b></p>  <p>Bolt, #10-24 x 1/2"</p>	<p><b>96</b></p>  <p>1/4"-20 x 3/4" Self-Drilling Screw</p>	<p><b>128</b></p>  <p>Insulated Staple</p>
<p><b>112</b></p>  <p>Bolt, 5/16"-18 x 1/2"</p>	<p><b>91</b></p>  <p>Bolt, 3/8"-16 x 7/8"</p>	<p><b>Wall Control Screw</b></p>  <p>Pan Head Screw #6 x 1-1/4"</p>
<p><b>127</b></p>  <p>Phillips Hex Head Screw, No. 10 x 1-1/4"</p>	<p><b>92</b></p>  <p>Nut, 3/8-16</p>	<p><b>10</b></p>  <p>Pan Head Phillips Screw No. 8 x 5/8"</p>
<p><b>79</b></p>  <p>Lag Screw, 1/4" x 2"</p>	<p><b>90</b></p>  <p>Clevis Pin</p>	<p><b>9</b></p>  <p>Hex Head Screw No. 8 x 3/4"</p>
<p><b>81</b></p>  <p>Speed Nut</p>	<p><b>89</b></p>  <p>Cotter Pin</p>	<p><b>N/A</b></p>
<p><b>82</b></p>  <p>Cold Head Pin</p>	<p><b>N/A</b></p>	<p><b>N/A</b></p>
<p><b>N/A</b></p>	<p><b>N/A</b></p>	<p><b>N/A</b></p>
<p><b>N/A</b></p>	<p><b>N/A</b></p>	<p><b>N/A</b></p>

## Stealth Power Head

6

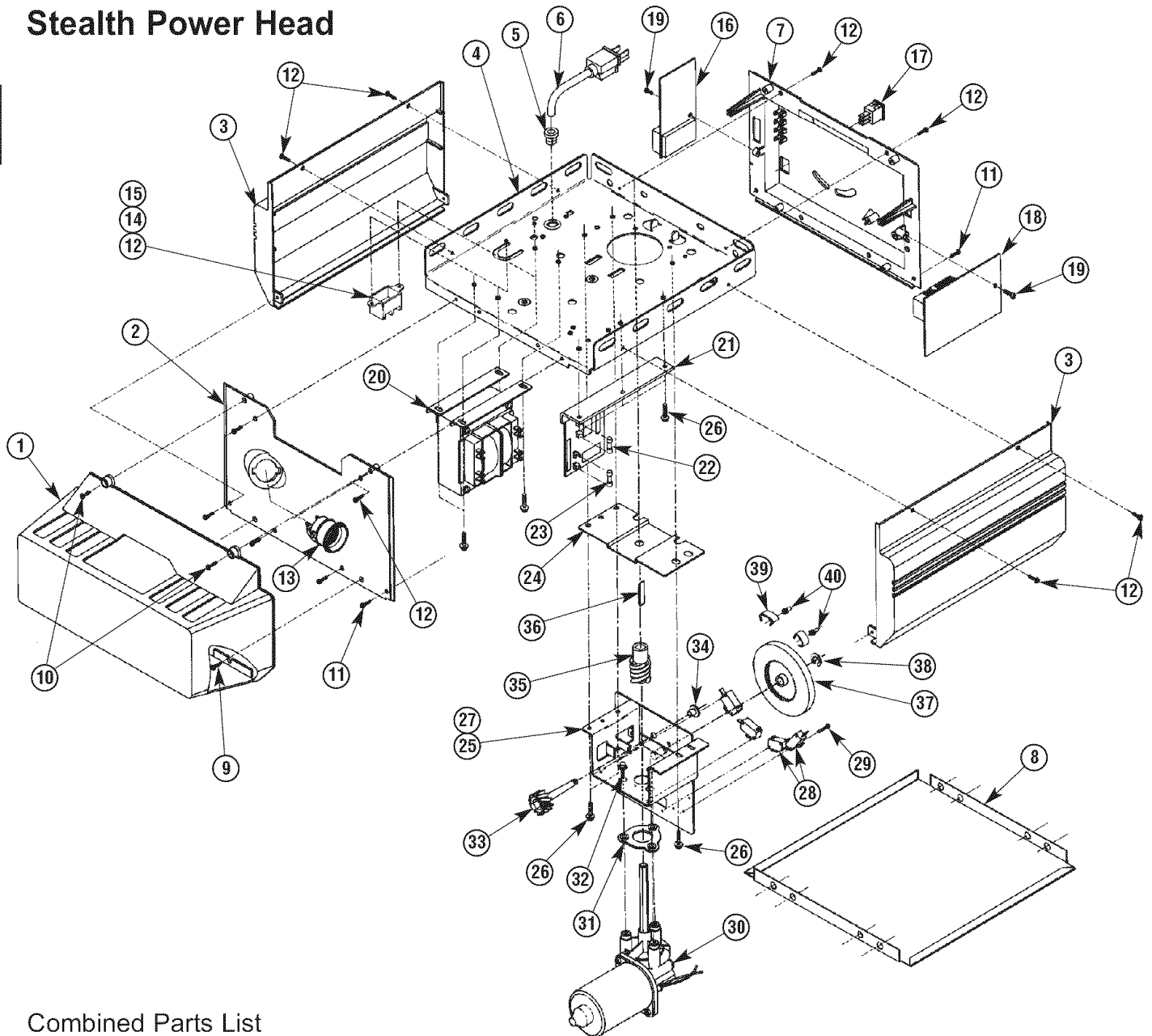

## Combined Parts List

Item	Part Name	Item	Part Name	Item	Part Name
1	Lens	21	Rectifier Board Assembly	41	Capacitor
2	Front Cover	22	Fuse (F1), UL	42	Capacitor Clamp
3	Side Cover (by series/model)	23	Fuse (F2), UL	43	Screw, #10-24 x 1/2", Slot HH Sf-Tap
4	Top Plate Assembly	24	Limit Gear Shroud	44	Nut, #10-32, Hex Serrated Flange
5	Strain Relief	25	Motor Bracket	45	Circuit Board
6	Cord & Plug Assembly	26	Screw, #10 x 3/8" HH	46	C.B. Bracket
7	Component Panel (by series/model)	27	Limit Plate/Pin Assembly	47	Circuit Board Mount
8	Bottom Cover	28	Limit Switch	48	Screw, #10-16 x 5/8", HH Sf Tap
9	Screw, #8 x .75 Phil Hx Hd/W Sf Tap	29	Screw, #4-40 x 5/8" Slot HH w/Wshr, Sf Tap	49	Top Gear Housing
10	Screw, #8 x .62 Phil Pan Hd/W Sf Tap	30	Motor Assembly	50	Middle Gear Housing
11	Screw, #8 x .50 Slit Hx Hd/W Sf Tap	31	Motor Adapter Plate	51	Bottom Gear Housing
12	Screw, #8 x .38 Slit Hx Hd/W Sf Tap	32	Screw, 1/4"-20 x 1/2" Slit HH w/Wshr	52	Drive Shaft Bushing
13	Light Socket (by series/model)	33	Limit Worm Gear	53	Drive Thrust Washer
14	Terminal Block & Lug	34	Limit Gear Bushing	54	Drive Shaft
15	M.O.V. Assembly	35	Limit Worm Drive	55	1/2" Retaining Ring
16	Receiver Assembly	36	Limit Worm Shim	56	Main Drive Worm Gear
17	Limit Set Switch	37	Limit Wheel	57	Optical Interrupt Wheel
18	Sequencer Assembly	38	Retaining Ring	58	Motor Flanged Bushing
19	Screw, #6 x .38 Slit Hx Hd/W Sf Tap	39	Limit Cam	59	Motor Thrust Washer
20	Transformer Assembly (by series/model)	40	Limit Pinion, 8 tooth	60	Poly Thrust Washer



PRO-MAX Power Head

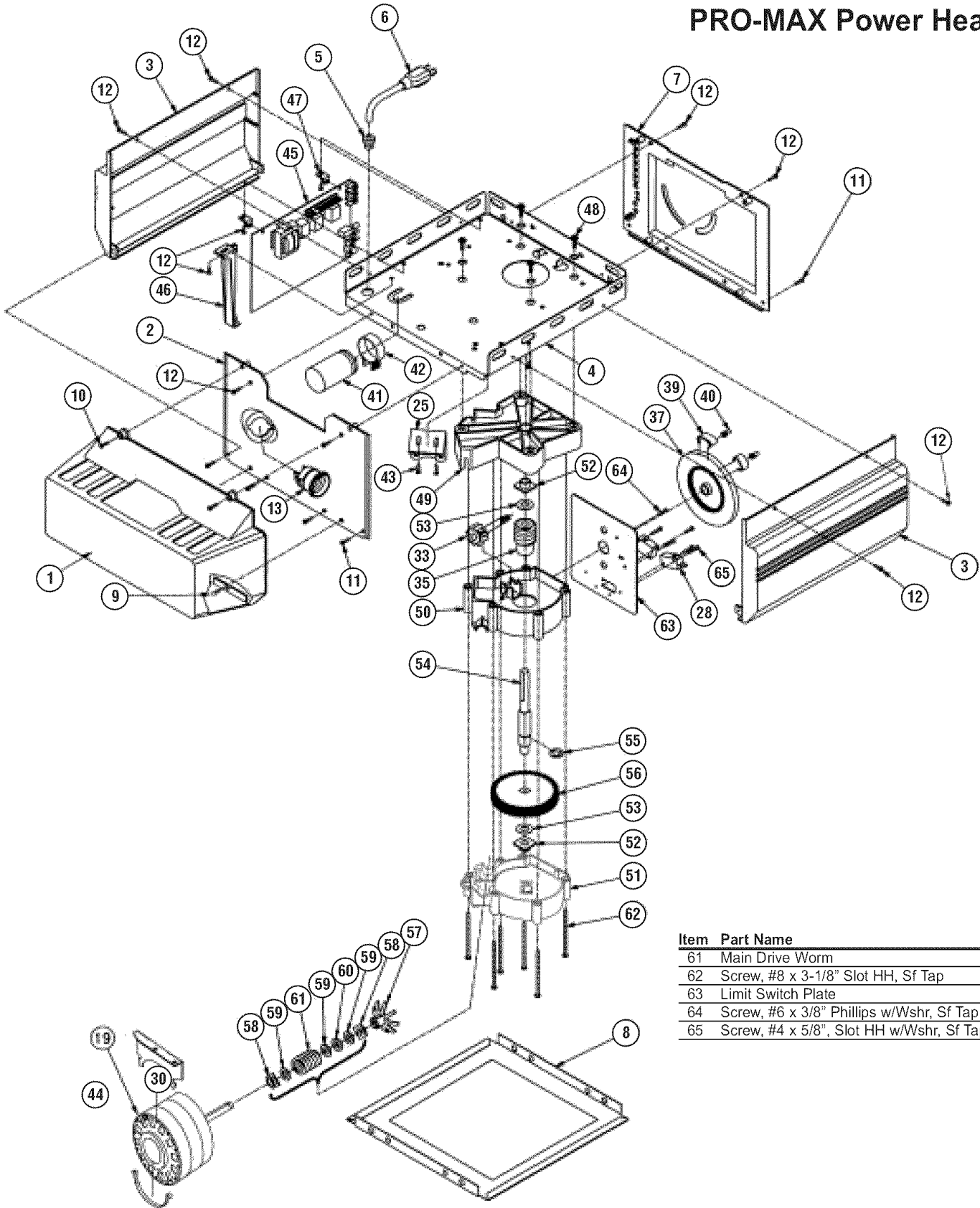

Item	Part Name
61	Main Drive Worm
62	Screw, #8 x 3-1/8" Slot HH, Sf Tap
63	Limit Switch Plate
64	Screw, #6 x 3/8" Phillips w/Wshr, Sf Tap
65	Screw, #4 x 5/8", Slot HH w/Wshr, Sf Tap

# Channel

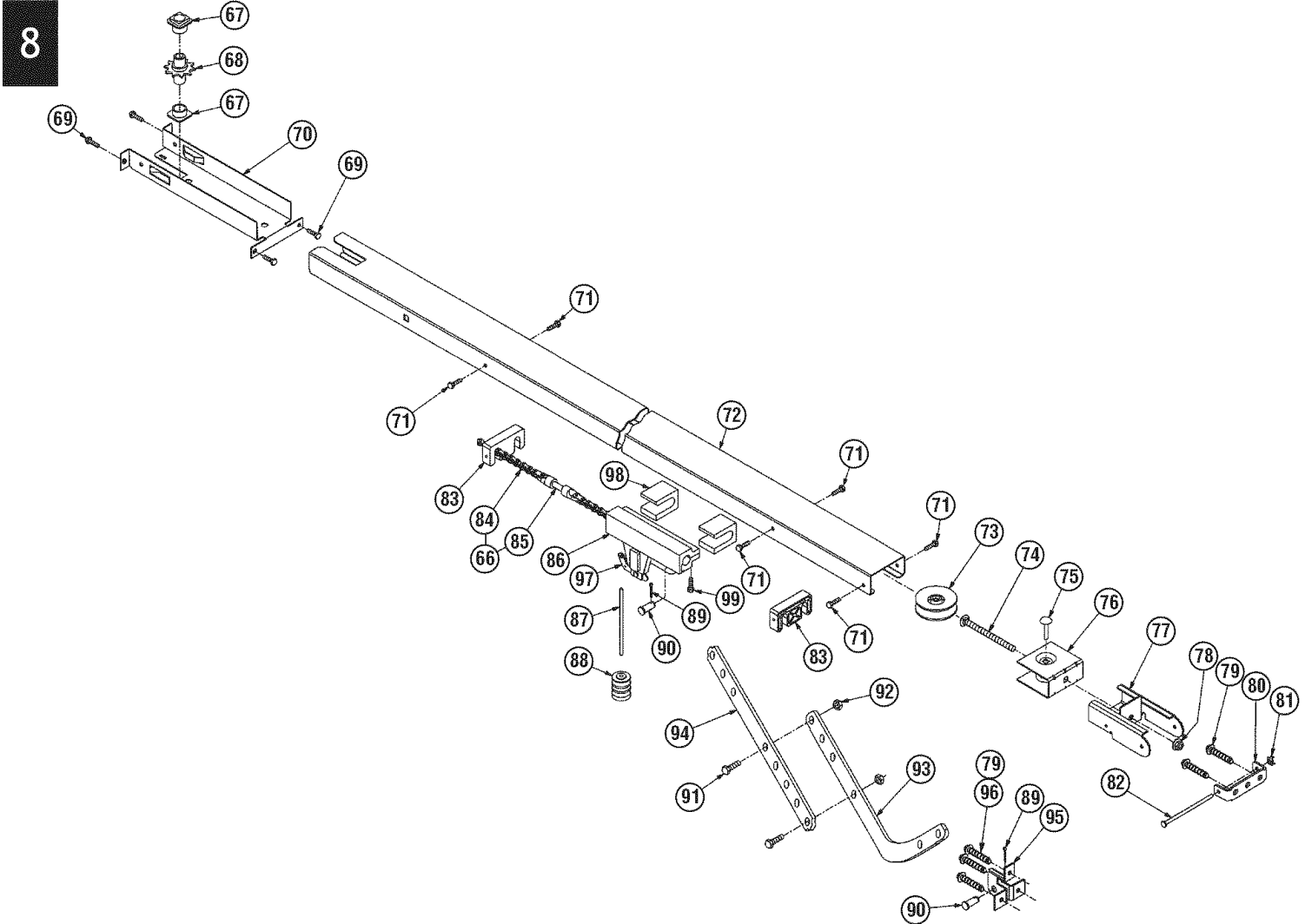

## Combined Parts List

Item	Part Name	Item	Part Name	Item	Part Name
66	Belt & Bullet Assembly - 7'6" Door (Belt Models Only)	72	Channel - 7'6" Door (128" LG)	85	Chain Bullet
	Belt & Bullet Assembly - 8' Door (Belt Models Only)		Channel - 8' Door (146" LG)		Belt Bullet
	Belt & Bullet Assembly - 10' Door (Belt Models Only)		Channel - 10' Door (170.75" LG)		Belt Retainer
	Belt & Bullet Assembly - 12' Door (Belt Models Only)		Channel - 12' Door (188" LG)		Screw, #6-32 x 1/2" Phil Pan Hd Slf Tap
67	Sprocket Bushing	73	Pulley (Chain Models Only)	86	Carriage Slide
68	Sprocket, 10 Tooth - 7'6" & 8' Doors (Chain Models Only)		Pulley (Belt Models Only)	87	Emerg. Release Cord - 7'6" Doors (26.5")
	Sprocket, 12 Tooth - 10' Door (Chain Models Only)	74	Carriage Bolt, 5/16"-18 x 4.0		Emergency Release Cord - 8' & 10' Doors (56.5")
	Drive Sprocket, 18 Tooth - 7'6" & 8' Doors (Belt Models Only)	75	Carriage Pin, 5/16" x 1.25		Emergency Release Cord - 12' Doors (96.0")
	Drive Sprocket - 10' Door (Belt Models Only)	76	Pulley Bracket Assembly	88	Emergency Release Knob (Red)
69	Screw, #10-24 x .50 Hx Hd	77	End Bracket	89	Cotter Pin
70	Sprocket Bracket (Chain Models Only)	78	Hex Flange Nut, 5/16"-18 (Chain Only)	90	Clevis Pin
	Sprocket Bracket - 7'6" & 8' Doors (Belt Models Only)		Flat Washer (Belt Models Only)	91	Screw, 3/8"-16 x .87 Hx Hd Mch
	Sprocket Bracket - 10' Door (Belt Only)	79	Lag Screw, 1/4" x 2" Hx Hd/W	92	Hex Nut, 3/8"-16
	Sprocket Bracket - 12' Door (Belt Only)	80	Header Bracket	93	Curved Door Arm
71	Screw, #10-24 x .38 Hx Hd/W	81	Speed Nut	94	Straight Door Arm
		82	Cold Header Pin	95	Door Bracket
		83	Carriage Stop	96	Screw, 1/4"-20 x 3/4" Hx Hd, Sf Tap
		84	Roller Chain - 7'6" Door (Chain Only)(242.5")	97	Carriage Assembly
			Roller Chain - 8' Door (Chain Only)(278.5")	98	Carriage Cap
			Roller Chain - 10' Door (Chain Only)(328.5")	99	Screw, #10-14 x 1-5/16" Hx Hd
			8mm Belt	100	Wall Console (Series II )
				101	Wall Button (Series II ) (lit primary)
					Wall Button (unlit secondary)



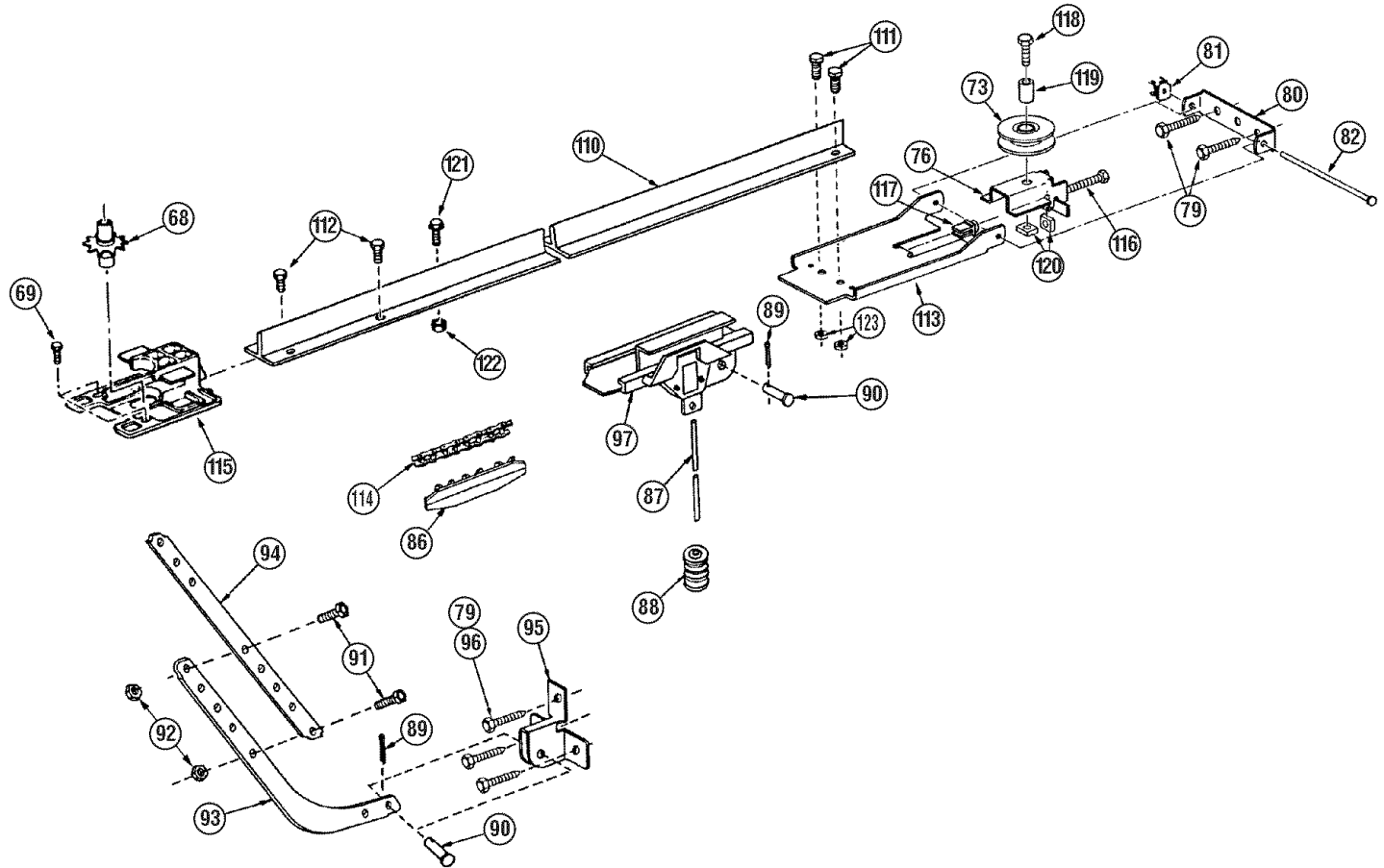

Item	Part Name	Item	Part Name
102	Boom Support Kit (not shown)	125	STB System Source (Red LED)
103	Safety & Maintenance Guide	126	STB Mounting Brackets (2)
104	Emergency Release Tag (Tri-L)	127	Screw, 1-1/4" Phillips HH
105	Entrapment WARNING Label	128	Insulated Staples
106	Wire		
110	Rail (L=112.475")		
111	Screw, 5/16"-18 x 3/4"		
112	Screw, 5/16" x 1/2" HH w/Wshr		
113	Pulley Support		
114	Chain		
115	Sprocket Saddle		
116	Screw, 5/16"-18 x 2-1/4" HH		
117	Bolt Retainer		
118	Screw, 5/16"-18 x 1-1/8" HH		
119	Large Pulley Bushing		
120	Square Nut, 5/16"-18		
121	Screw, 1/4"-20 1" HH		
122	Hex Nut/Lockwasher, 1/4"-20		
123	5/16-18 Lock Nut		
124	STB System Sensor (Green LED)		

# 1... OPERATOR ASSEMBLY

FOR HELP-1.800.354.3643 OR GENIECOMPANY.COM

## OPEN BLUE PARTS BAG

Screws for attaching light cover are included in this bag. Please set aside for use later.

10

1. **Attach emergency release knob cord (Fig. 1-1).**
  - Tie overhand knot in end of cord.
  - Thread cord through knob so knot is inside knob.
  - Thread cord through hole in carriage lever.
  - Tie overhand knot in other end of cord.

**Do Not** cut cord until after power head is mounted.

2. **Attach emergency release tag (Fig. 1-1).**
  - Thread wire through hole in carriage lever.
  - Wrap wire around itself, tie securely.

PLEASE NOTE THE ASSEMBLY PROCEDURES ARE DIFFERENT FOR RAIL AND CHANNEL. BE SURE TO FOLLOW THE APPLICABLE STEPS.

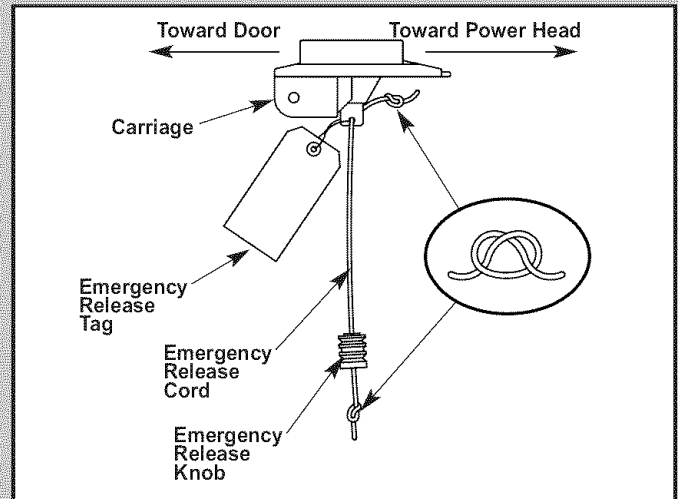

Fig. 1-1

## CHANNEL & POWER HEAD ASSEMBLY

### CAUTION

**Do Not** attempt to run power head or to set limits until operator is fully assembled and attached to the door.

3. Place power head and channel on clean, flat surface.
4. **Slide drive end of channel down over "D"-shaft on top of power head (Fig. 1-2).**
  - Support header end of channel level with power head.
  - Slide carriage to align "D"-shaft with "D"-hole in sprocket.
  - Slide channel down "D"-shaft flush with power head.
5. **Fasten channel to power head .**
  - Align mounting holes in front and rear of power head frame.
  - Insert and securely tighten the four (4) No. 10 x 1/2" hex head screws [69].

*NOTE: Chain inner-slide or belt bullet should remain at mid-travel when assembling to power head to provide proper travel when setting limits.*

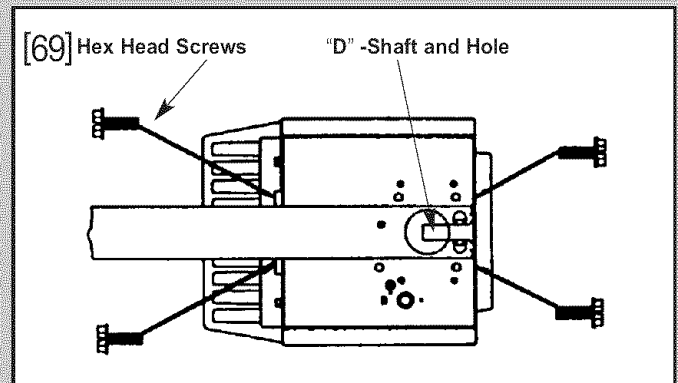

Fig. 1-2



No. 10 x 1/2" Hex Head Screw

## RAIL & POWER HEAD ASSEMBLY

### CAUTION

**Do Not** attempt to run power head or to set limits until operator is fully assembled and attached to the door.

3. Place power head and rail on clean, flat surface.
4. **Slide drive end of rail down over "D"-shaft on top of power head (Fig. 1-3).**
  - Support header end of rail level with power head.
  - Slide carriage enough to align "D"-shaft with "D"-hole in sprocket.
  - Slide rail down "D"-shaft flush with power head.

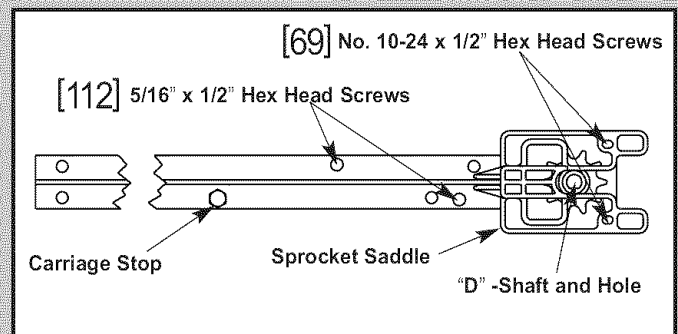
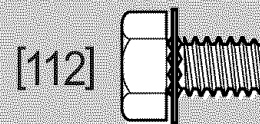

Fig. 1-3



5/16" x 1/2" Hex Head Washer Screw



**5. Fasten rail to power head.**

- Align mounting holes of sprocket saddle, rail and power head frame.
- Insert the two (2) 5/16" x 1/2" hex head screws [112], then two (2) No. 10-24 x 1/2" hex head screws [69].
- Tighten screws.

*NOTE: Inner-slide/bullet should remain at mid-travel when assembling to power head to provide proper travel when setting limits.*

**6. Use adjusting bolt to set chain tension (Fig. 1-4)**

- Chain should sag slightly but not so much that it drags on the rail.

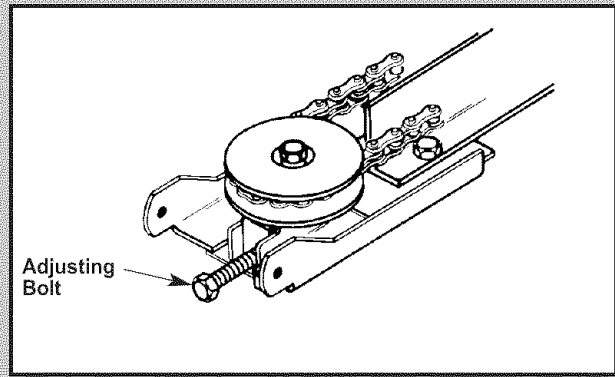

Fig. 1-4

**OPEN ORANGE PARTS BAG**

**2... INSTALLATION**

FOR HELP-1.800.354.3643 OR GENIECOMPANY.COM

**IMPORTANT  
INSTALLATION  
INSTRUCTIONS**

**⚠ WARNING:**

**To reduce the risk of severe injury or death:**

1. READ AND FOLLOW ALL SAFETY, INSTALLATION AND OPERATION INSTRUCTIONS. If you have any questions or do not understand an instruction, call your service representative.
2. Do Not install operator on an improperly balanced door. An improperly balanced door could cause severe injury. Repairs and adjustments to cables, spring assembly, and other hardware must be made by a trained service person using proper tools and instructions.
3. Remove all ropes and disable all locks connected to the door before installing operator.
4. Install door operator 7 feet or more above the floor. Mount the emergency release knob 6 feet above the floor.
5. Do Not connect the operator to the source of power until instructed to do so.
6. Locate the control button:
  - Within sight of door.
  - At a minimum height of 5 feet, so small children cannot reach it.
  - Away from all moving parts of the door.
7. Install the entrapment WARNING label next to the wall button or console. Install the emergency release tag on, or next to, the emergency release.
8. The operator must reverse when the door contacts a 1-1/2 inch high object on the floor at the center of the doorway. This is about the size of a 2" x 4" board laid flat.

**WHAT TYPE OF DOOR DO YOU HAVE?**  
Look at the drawings below. They tell you where to find the installation instructions you need

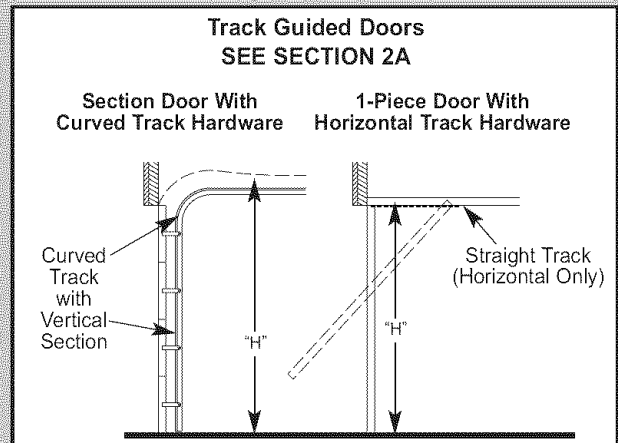

DOTTED LINE AT "H" INDICATES HIGHEST POINT OF TRAVEL

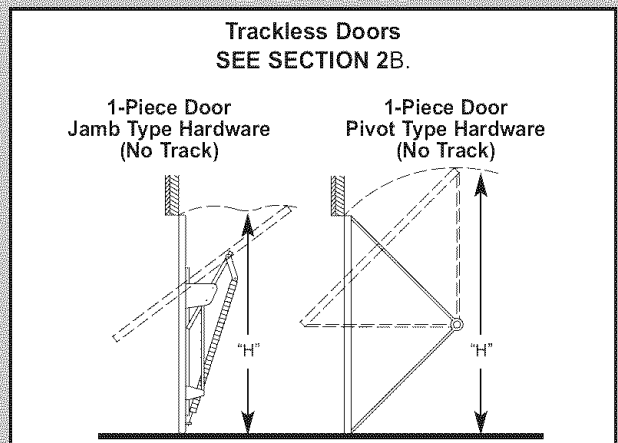

## Alternate Mounting Methods

NOTE: Materials for mounting are not included

12

### Angle Iron Method

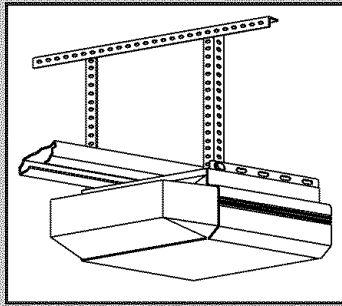

### Conduit Method

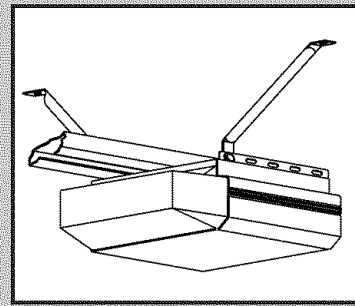

## 2A... FOR TRACK GUIDED DOORS

– FOR TRACKLESS DOORS GO TO PAGE 15 –

### ⚠ WARNING

- Do Not try to remove, repair or adjust springs or anything to which door spring parts are fastened, such as, wood blocks, steel brackets, cables or other like items. Repairs and adjustments must be made by a trained service person using proper tools and instructions.
- Handles and other door projections can catch clothing. Remove ropes, hooks, hangers, decorative or security items mounted to door.
- Be sure Emergency Release Cord does not catch on roof carrier or other vehicle parts.

1. Establish center line of door and header (Fig. 2-1).
  - Close door.
  - Measure door width. Mark center.
  - Use straight edge to draw vertical line "V."
    - down door about 6".
    - on top of door.
    - up header about 20".
2. Establish Header Bracket position (Fig. 2-2).
  - Watch top edge of door as you raise it.
  - Stop door when top edge reaches highest point of travel.
  - Measure distance from top edge of door to floor.
  - Add 2-1/2" to this measurement.
  - Close door.
  - Mark header at this height.
  - If door spring is in the way, mark header 2-1/2" above the spring.
  - Draw horizontal line "H" across line "V" at this point (Fig 2-1).

NOTE: Header bracket must be at least 2-1/2" above high point of door travel. It can be installed higher if door spring is in the way. Do Not move the spring.

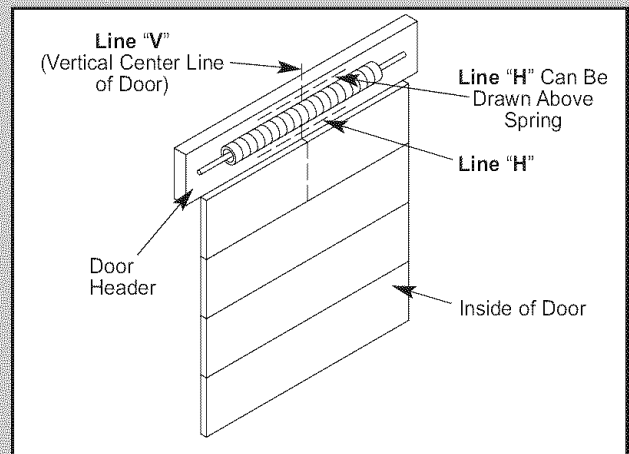

Fig. 2-1

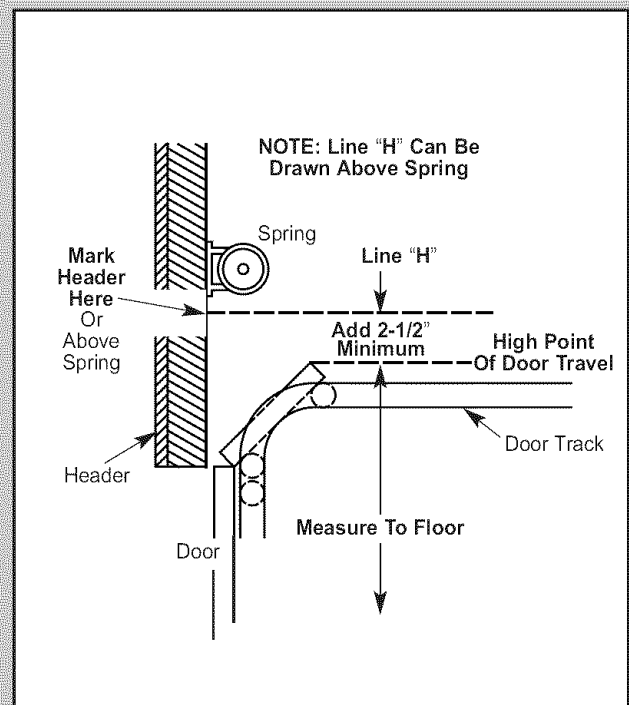

Fig. 2-2



### CAUTION

Header bracket must be fastened to garage framing. Do Not fasten to drywall, particle board, plaster or other such materials.

#### 3. Install header bracket (Fig. 2-3)

- Place bracket so:
  - center hole is on line "V."
  - all holes are on line "H."
- Mark hole positions "A" and "B."
- Drill 5/32" holes at marked positions.
- Fasten bracket to header using two (2) 1/4" x 2" lag screws [79].

#### 4. Attach channel/rail assembly to header bracket (Fig. 2-4).

- Fasten header end of the channel/rail to the Header bracket with cold header pin [82].
  - Install speed nut [81].
  - Support power head above floor, use:
    - rope.
    - ladder with cardboard packing.
    - wood.
- #### 5. Level rail assembly and power head (Fig. 2-5).
- Raise and support power head above door tracks.
  - Open door.
  - Level channel/rail assembly and support temporarily.
  - Center channel/rail assembly and power head on line "V" of door.

*NOTE: The channel/rail assembly and power head should be level if possible. If necessary, power head may be mounted lower. However mounted, moving door must not touch channel/rail assembly.*

### CAUTION

Mounting bracket must be fastened to garage framing. Do Not fasten to drywall, particle board, plaster or other such materials.

#### 6. Mount power head (See Section 2 MOUNTING METHODS).

- Be sure channel/rail assembly and power head are on door center line (Line "V").
- Check the illustrations. Decide which mounting method you will use. Materials for mounting are not included.
- After power head is installed, remove supporting material.
- Close door.

#### 7. Install door braces (See CAUTION below).

### CAUTION

Doors made of masonite, lightweight wood, fiberglass, and metal must be properly braced before mounting Door Operator.

Contact door manufacturer or distributor for bracing instructions.

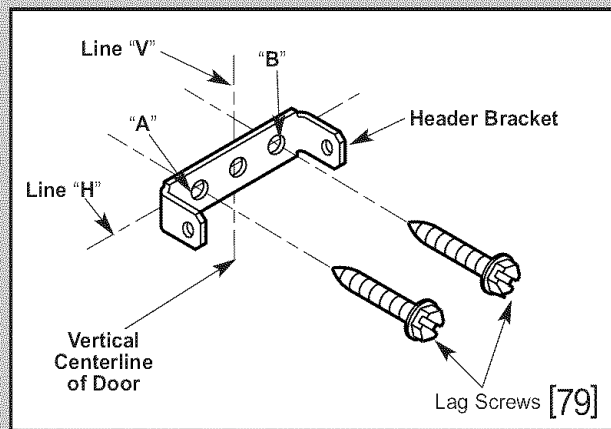

Fig. 2-3

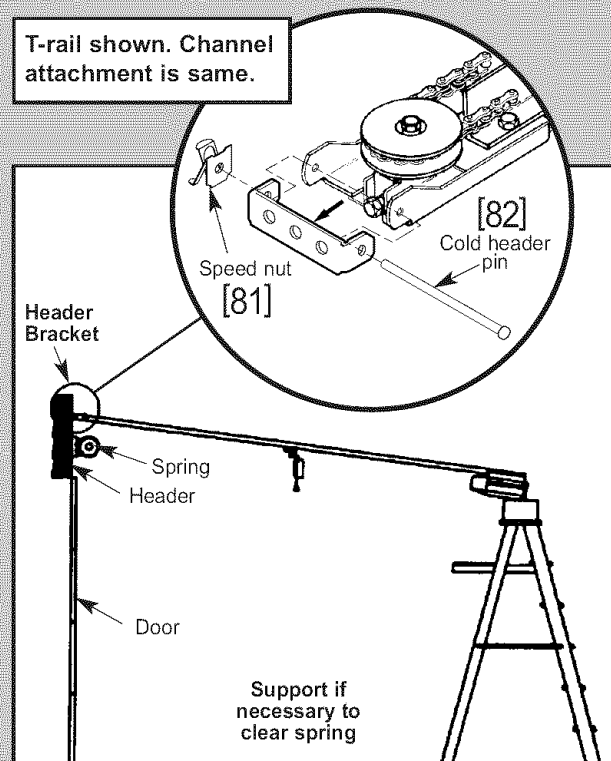

Fig. 2-4

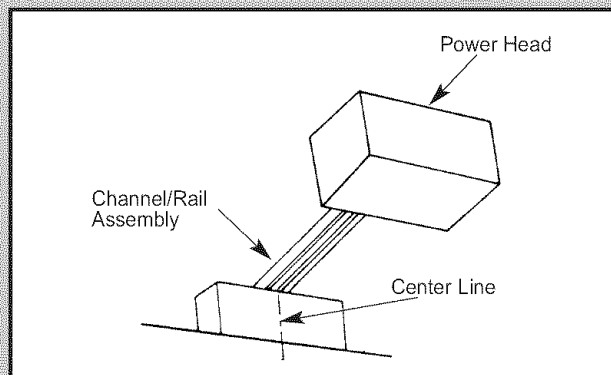
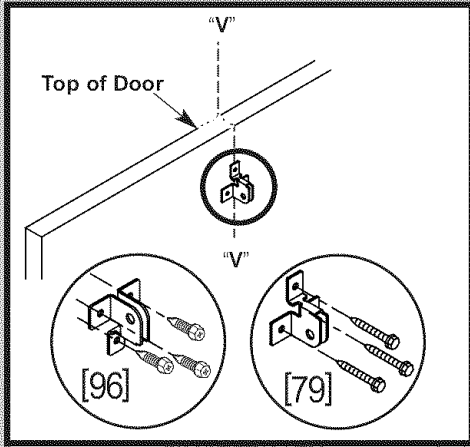
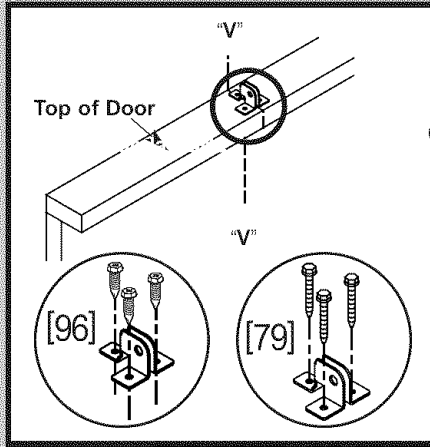

Fig. 2-5



Sectional doors



One-piece doors

Fig. 2-6

**8. Install door bracket (Fig. 2-6).**

- Contact door manufacturer.

*NOTE: Self-drilling screws are intended for use with light-weight door only, while lag screws are meant for wood doors only.*

*Because door designs vary, modifications may be required and additional materials needed. Please contact your door manufacturer with any questions concerning your door.*

**OPEN YELLOW PARTS BAG**

**9. Install door arms (Fig. 2-7).**

- Attach straight door arm to carriage.
  - slip straight door arm into slot at bottom of carriage as shown.
  - secure with clevis pin [90] and cotter pin [89].
- Attach short end of curved door arm to door bracket as shown.
  - slip short end of curved door arm into slot in door bracket.
  - secure with clevis pin and cotter pin.
- Release carriage (See emergency release tag).
  - slide carriage towards closed door.
  - stop carriage 14" minimum from door.

**10. Join door arm sections (Fig. 2-8).**

- Use two (2) 3/8" x 7/8" hex bolts [91], and hex flange nuts [92].
  - use any two holes as far apart as possible.
  - slide carriage back and forth as needed to align holes.
- Tighten hex nuts securely.

**11. Adjust emergency release cord length.**

- Mount the emergency release knob 6 feet from the floor.
- Retie overhand knot and trim excess cord.

**DO NOT plug power cord into outlet.**

**Go to Section 3-SAFE-T-BEAM® SYSTEM INSTALLATION.**

– PROCEED TO PAGE 18 –

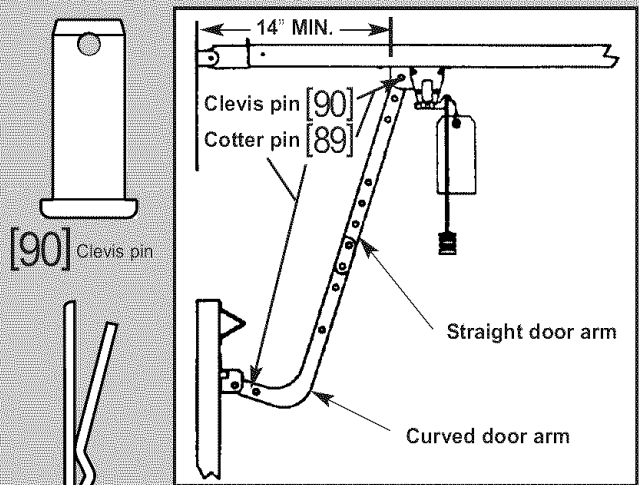
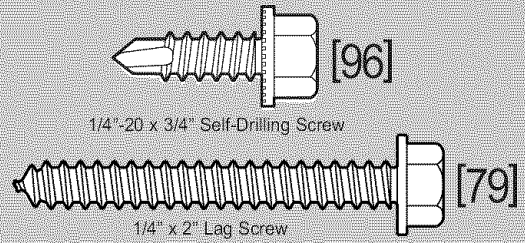

Fig. 2-7

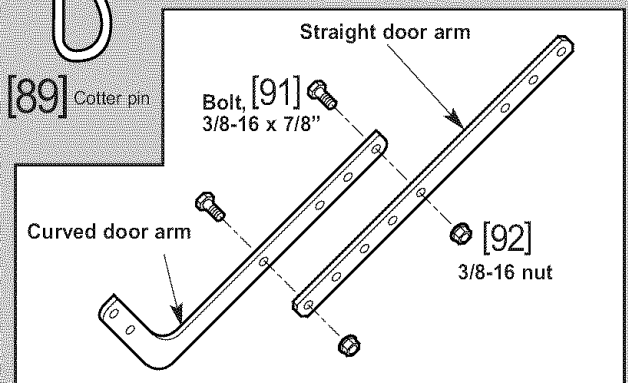
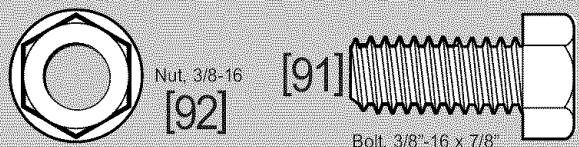

Fig. 2-8



## ⚠ WARNING

- **Do Not** try to remove, repair or adjust springs or anything to which door spring parts are fastened, such as, wood blocks, steel brackets, cables or other like items.

Repairs and adjustments must be made by a trained service person using proper tools and instructions.

- Handles and other door projections can catch clothing. Remove ropes, hooks, hangers, decorative or security items mounted to door.
- Be sure emergency release cord does not catch on roof carrier or other vehicle parts.

### 1. Establish center line of door and header (Fig. 2-9).

- Close door.
- Measure door width. Mark center.
- Use straight edge to draw vertical line "V."  
– down door about 6."  
– on top of door.
- up header about 20".

### 2. Determine door rise (Fig. 2-10).

- Open door to highest point of travel.
- Measure distance from top of door to floor.
- Subtract the actual height of door. The remainder is the door rise in inches as shown in TABLE A.

TABLE A

Door rise in inches	Locate header bracket above top edge of CLOSED door
Up to 4"	Up to 10"
4" to 8"	10" to 15"
8" to 12"	15" to 20"

### 3. Locate header bracket (Fig. 2-9).

- Use TABLE A to determine header bracket position.
- Draw horizontal line "H" across line "H" at this point.

## ⚠ CAUTION

Header bracket must be fastened to garage framing. Do Not fasten to drywall, particle board, plaster or other such materials.

### 4. Install header bracket (Fig. 2-11).

- Place header bracket so,  
– center hole is on line "V."  
– all holes are on line "H."
- Mark hole positions ("A" and "B").
- Drill 5/32" holes at marked positions.
- Fasten header bracket to header with two (2) 1/4" x 2" lag screws [79].

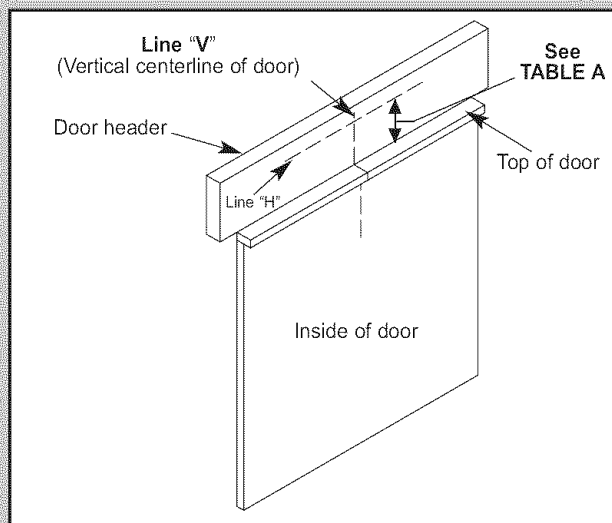

Fig. 2-9

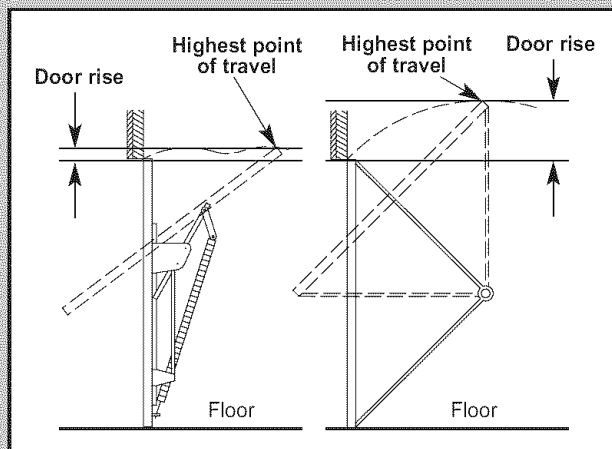

Fig. 2-10

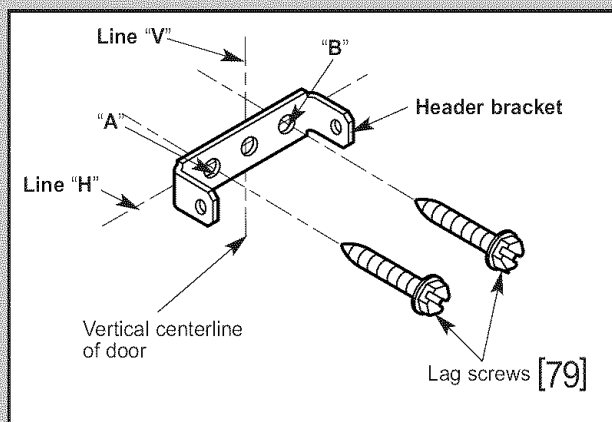

Fig. 2-11

5. Install door braces  
(See CAUTION below).

**CAUTION**

Doors made of masonite, lightweight wood, fiberglass, and metal must be properly braced before mounting an operator.

Contact door manufacturer or distributor for bracing instructions.

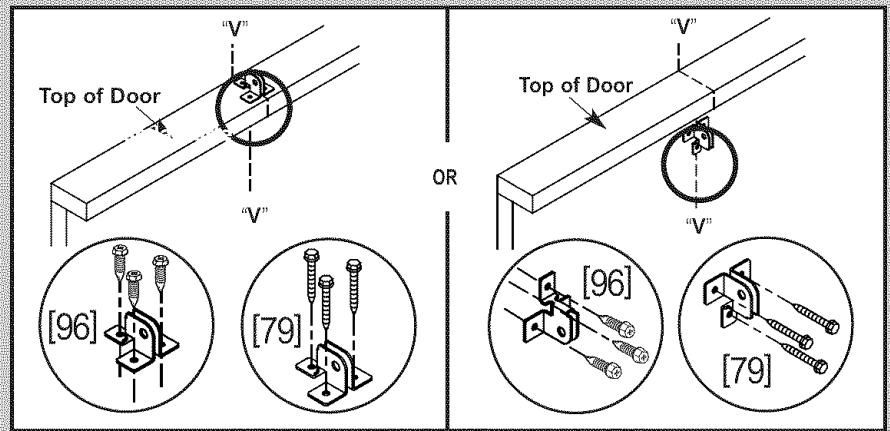

Fig. 2-12

6. Install door bracket (Fig. 2-12).

- Contact door manufacturer for proper installation.

*NOTE: Self-drilling screws are intended for use with light-weight door only, while lag screws are meant for wood doors only.*

*Because door designs vary, modifications may be required and additional materials needed. Please contact your door manufacturer with any questions concerning your door.*

7. Attach channel/rail assembly to header bracket (Fig. 2-13).

- Fasten header end of the channel/rail to the header bracket with pin.
- Install speed nut onto pin (Fig. 2-14).
- Place cardboard packing under power head. Use additional support if needed.

8. Establish power head mounting height (Fig. 2-15).

- Power head should be at door height above floor or higher.
- Temporarily support power head in this position. Use
  - rope.
  - ladder with cardboard packing.
  - wood.

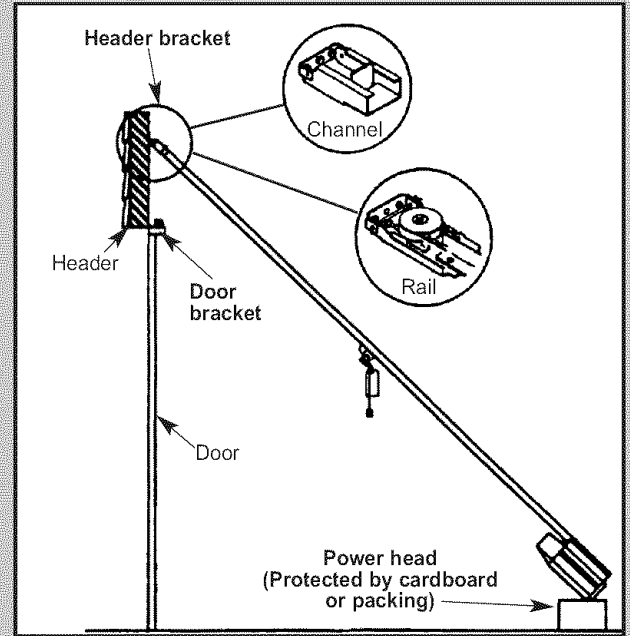

Fig. 2-13

Same arrangement applies to channel (not shown)

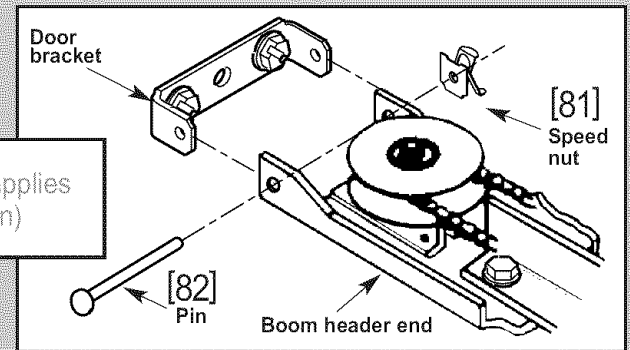

Fig. 2-14

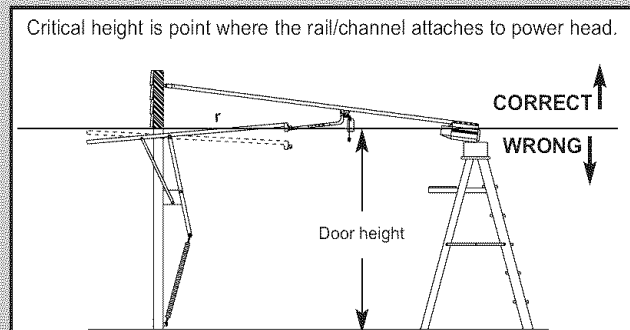

Fig. 2-15



## OPEN YELLOW PARTS BAG

### CAUTION

Mounting bracket must be fastened to garage framing. Do Not fasten to drywall, particle board, plaster or other such materials.

#### 9. Mount power head (See Section 2 ALTERNATE MOUNTING METHODS).

- Be sure rail assembly and power head are on door center line (line "V").
- Check the illustrations. Decide which mounting method you will use. Materials for mounting are not included.
- After power head is installed, remove supporting material.
- Close door.

#### 10. Join door arms exactly as shown (Fig. 2-16).

- Overlap arms by two (2) holes.
- Install two (2) 3/8" x 7/8" hex bolts, and hex flange nuts.
- Tighten hex nuts securely.

#### 11. Install assembled door arms (Fig. 2-17).

- Attach straight end of assembled door arms to door bracket.
  - slip straight door arm into slot in door bracket.
  - secure with clevis pin [90] and cotter pin [89].
- Release carriage (See emergency release tag).
- Slide carriage toward door.
- Attach short end of curved door arm to carriage.
  - slip curved door arm into slot in carriage.
  - secure with clevis pin and cotter pin.

*NOTE: When opening, door must not pass level position or if you are not able to close the door after completing previous step; a longer door arm is required. An extension kit can be purchased by calling the Customer Service phone number, 1.800.354.3643.*

#### 12. Adjust emergency release cord length.

- Mount the emergency release knob 6 feet from the floor.
- Retie overhand knot and trim excess cord.

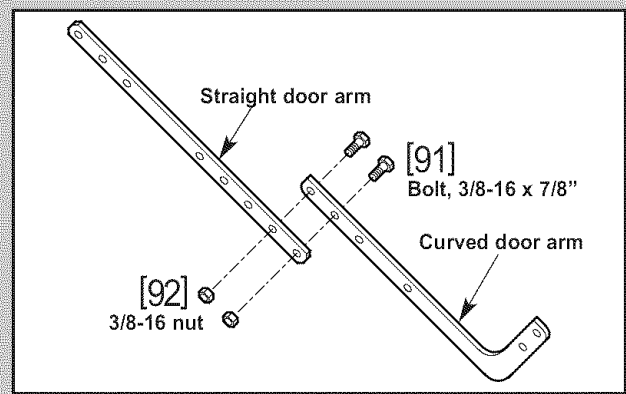

Fig. 2-16

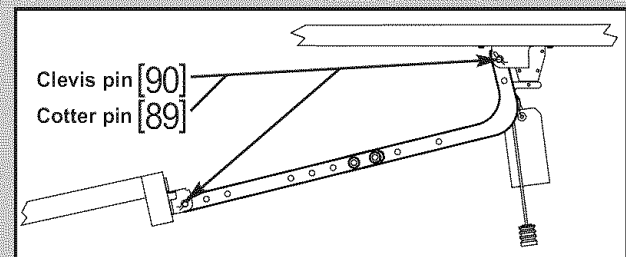
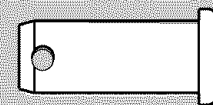
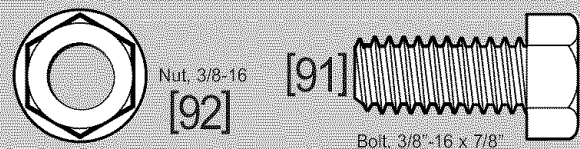

Fig. 2-17



[90] Clevis pin



[89] Clevis pin

### 3... SAFE-T-BEAM® INSTALLATION

FOR HELP-1.800.354.3643 OR GENIECOMPANY.COM

#### ⚠ WARNING

There should be no electrical power to the operator while installing Safe-T-Beam® System wires. If you have plugged in the power cord —UNPLUG IT NOW.

*NOTE: The operator will not close the door automatically unless the Safe-T-Beam® System is installed.*

#### 1. Mounting brackets.

- Mark both sides of garage door frame or wall 5" above floor (Fig. 3-1).
- Hold bracket against door frame or wall.
  - Check if brackets extend out from wall far enough, so tongue of bracket is beyond door, tracks or any door hardware.
  - If not:
    - a. STB bracket extensions are available at local dealer.
    - b. Blocks of wood, etc. may be substituted for extensions.
- Center bracket on your mark (Fig. 3-2).
- Fasten each with 2 screws [127].



*NOTE: Mounting brackets can be attached to the floor using concrete anchors (not provided).*

#### 2. Mounting STB source and sensor.

- If garage has only one garage door.
  - Determine which side of garage receives most direct sunlight (Fig. 3-4).
  - Red LED should always be on sunny side whenever possible (Fig. 3-4).
- For multiple doors.
  - Preventing crossed signals is critical.
  - Place source and sensor modules on adjacent doors facing in opposite directions (Fig. 3-4).

*NOTE: To help prevent interference from sun, STB sensors (green LED) may be placed further away from the door opening where they will spend more time in shadows.*

- Slide source/sensor onto tongue of bracket until it clicks into place (Fig. 3-3).

### OPEN RED PARTS BAG

#### 3. Wiring.

- Route wire using either method shown (Fig. 3-5).
- Securely fasten wires to wall as you go.
  - Use insulated staples (included).



- Staples should be snug only.

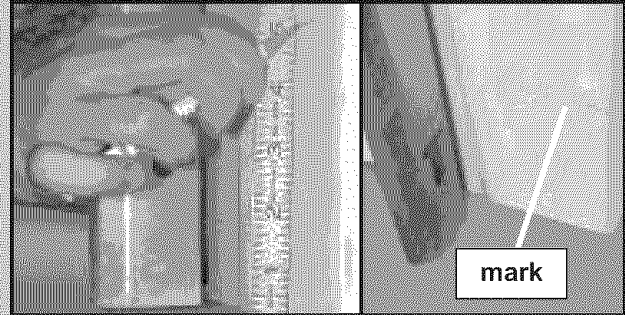

FIG. 3-1 Mark door frame.

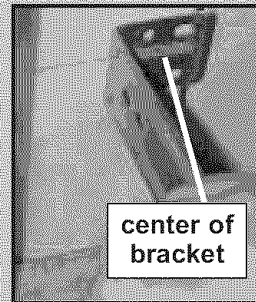

FIG. 3-2 Mount brackets.

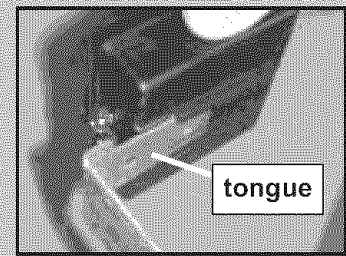

FIG. 3-3 Attaching STB's to brackets. (See directions on next page and Figure 3-4 before attaching.)

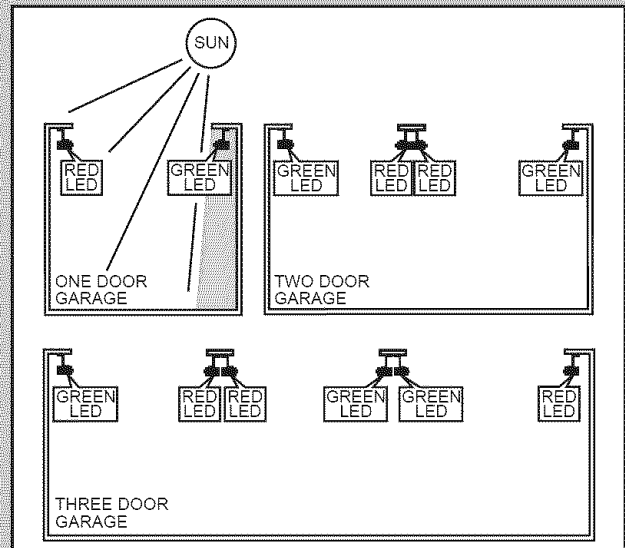

FIG. 3-4 STB locations.

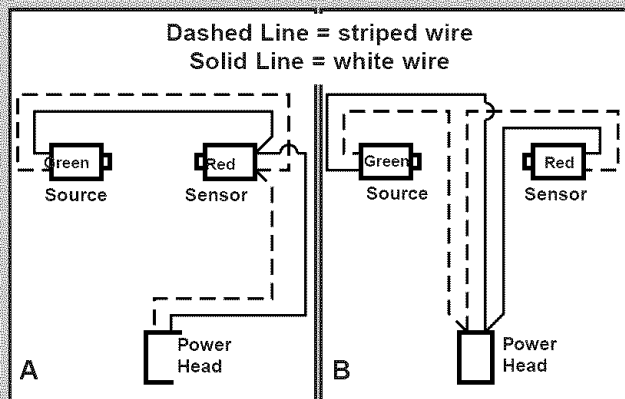

FIG. 3-5 STB wiring methods.

## ⚠ CAUTION

Staples which are too tight can cut or pinch wires. Cut or pinched wires can cause the STB System to stop working. When using the insulated staples, make sure you fasten them only as tightly as needed to hold the wire snugly.

- Make wire attachments at STB's.
    - Splitting and stripping wire ends to be connected as shown (Fig. 3-6).
    - Loosen terminal screws.
    - Insert wire under flat plate and tighten screw. It does not matter which wire, white or striped, goes on which terminal (Fig. 3-7).
  - Make wire attachments at power head.
    - For ProMax. STB's are connected to terminals #2 and #3 on power head (Fig. 3-8).
    - For Stealth. STB's are connected to terminals #3 and #4 on power head (Fig. 3-8).
4. Check the following.
- Insure that no part of door or its hardware is in path between lenses of **source** and **sensor**.
  - Insure that tops of lenses are between 5" - 6" above the floor (Fig. 3-9). The brackets are flexible and can be adjusted slightly if needed.

*NOTE: STB alignment check must be performed following connection to electrical power (see page 21). DO NOT PLUG IN YET!*

### Safe-T-Beam® Alignment Check

After turning the electrical power on, if the STB's are not in proper alignment, the red LED (Source) will blink continuously.

To correct the problem – the brackets are flexible and can be adjusted slightly to bring the system into alignment.

When the STB's are in alignment the red LED will stop blinking and stay on.

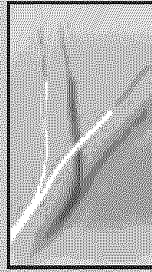

FIG. 3-6 Splitting and stripping.



FIG. 3-7 Attachments at STB.

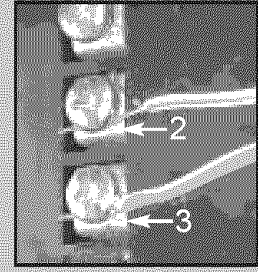

FIG. 3-8 (ProMax) Attachments at power head.

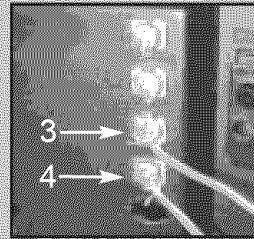

FIG. 3-8 (Stealth) Attachments at power head.

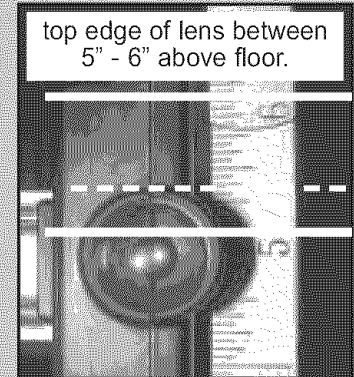

FIG. 3-9 Check lens height.

## STB SELF-DIAGNOSTIC TROUBLESHOOTING

SOURCE (RED LED)	SENSOR (GREEN LED)	INDICATED CONDITION	REQUIRED ACTION
● ON	● ON	NORMAL OPERATION	NONE REQUIRED
○ OFF	○ OFF	1. POWER HEAD NOT POWERED 2. WIRING FROM POWER HEAD BAD	1. CHECK BREAKERS, FUSES, PLUGS 2. CHECK WIRING FOR OBVIOUS SHORTS
○ OFF	● ON	1. WIRING TO SOURCE MISSING OR BAD 2. POWER HAS BEEN INTERRUPTED	1. CHECK WIRING 2. REMOVE POWER AND REAPPLY
2 BLINKS, PAUSE (REPEAT)	● ON	1. BEAM NOT ALIGNED 2. BEAM OBSTRUCTED 3. SENSOR DEFECTIVE	1. CHECK ALIGNMENT 2. CHECK FOR OBSTRUCTION 3. CALL CUSTOMER SERVICE
2 BLINKS, PAUSE (REPEAT)	○ OFF	1. WIRE TO SENSOR MISSING OR BAD 2. SENSOR DEFECTIVE	1. CHECK WIRING 2. CALL CUSTOMER SERVICE
3 BLINKS, PAUSE (REPEAT)	● ON	1. SENSOR RECEIVING INTERFERENCE	1. ATTEMPT TO DETERMINE SOURCE OF INTERFERENCE 2. CALL CUSTOMER SERVICE
4 BLINKS, PAUSE (REPEAT)	● ON	1. SOURCE NOT SENDING PULSES 2. SOURCE DEFECTIVE	1. CALL CUSTOMER SERVICE 2. CALL CUSTOMER SERVICE

**NOTE:** IF OPERATING PROBLEM EXISTS, THE DOOR CAN BE CLOSED IF YOU: 1. DISCONNECT THE STB SYSTEM FROM THE OPERATOR AND 2. HOLD WALL CONTROL BUTTON DOWN UNTIL DOOR IS CLOSED. (REMOTE CONTROL & WIRELESS KEYPAD WILL NOT WORK WITHOUT STB)

**CUSTOMER SERVICE: 1.800.354.3643 or www.geniecompany.com**



## 4... WALL CONTROL INSTALLATION

FOR HELP-1.800.354.3643 OR GENIECOMPANY.COM

20

### ⚠ WARNING

Power cord must be unplugged before attaching wires. Be sure wire ends do not touch each other or other terminals.

### ⚠ CAUTION

- Use of any other wall control will cause the light not to work and could cause door to operate by surprise.
- Cut or pinched wires can cause door operator to malfunction. Drive staples just tight enough to hold wire.

#### 1. Run wire from power head to wall control.

- Place the wall control:
  - In sight of door.
  - At least 5 feet from floor, so small children can not reach it.
  - Away from moving parts of door and door hardware.
- Use staples to fasten wire to ceiling and wall.

#### 2. Remove 1/2" insulation from each wire (Fig. 3-6)(pg. 19).

#### 3. Attach wires to terminals (Stealth Fig. 4-1a) (MAX Fig. 4-1b).

- Loosen, but Do Not remove screw from terminal.

##### For Stealth.

- Connect striped wires to terminal "2" on power head and "B" on wall control.
- Connect white wire to terminal "1" on power head and "W" on wall control.

##### For MAX.

- Connect striped wires to terminal "1" on power head and "B" on wall control.
- Connect white wire to terminal "2" on power head and "W" on wall control.

#### 4. Mount wall control (Fig. 4-2).

- Use two pan head screws.

#### 5. Mount entrapment warning label.

- Remove protective backing and stick near wall control.
- Use tacks or staples to permanently mount Label.
- Make sure everyone reads and follows WARNINGS.

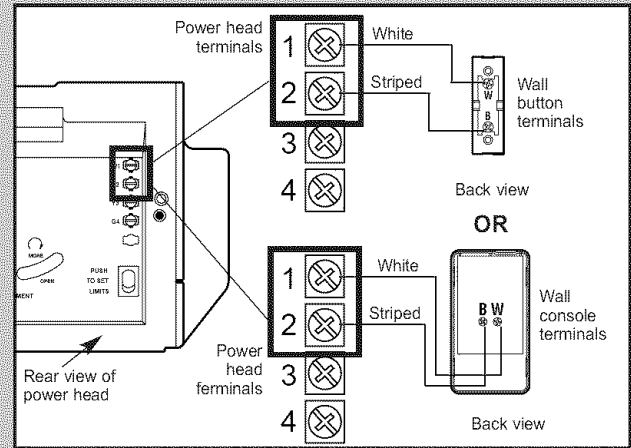

Fig. 4-1a

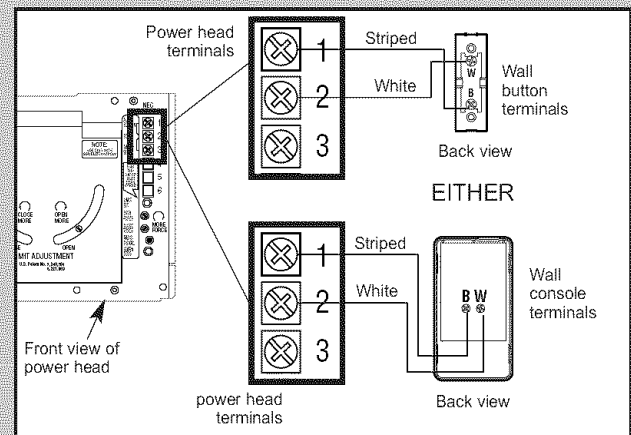

Fig. 4-1b

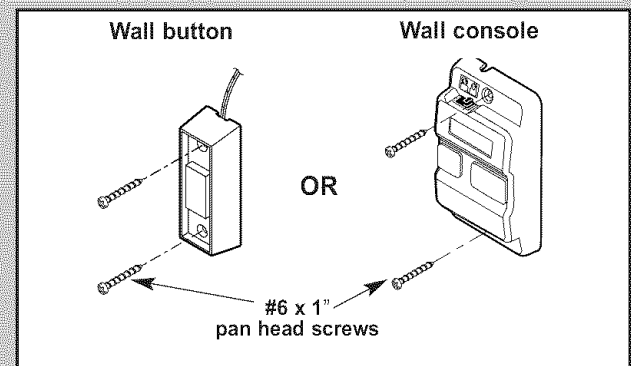

Fig. 4-2

##### Vacation Locking Switch

- LOCK disables controls after door is completely closed
- UNLOCK allows controls to work normally

##### Independent Light Control

- Controls door operator lights from inside garage
- Energy-Saver shut-off turns off light 5 minutes after door activation

##### Lighted Button

- Shows system is powered
- Lights when Security Lock Switch is in UNLOCK position
- Goes out when Security Lock Switch is in LOCK position

##### Door Control Button

- Open and closes door from inside garage

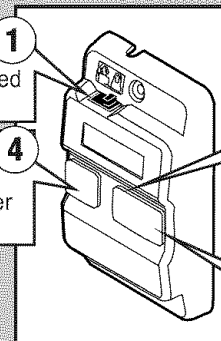

Fig. 4-3

NOTE: Additional wall controls are available from your dealer. ONLY ONE OF YOUR WALL CONTROLS MAY BE THE LIGHTED TYPE. If you have a lighted wall control, all your additional controls must be un-lighted. More than one lighted wall control per operator will cause a malfunction.



### ⚠ WARNING

To reduce the risk of electrical shock, this equipment has a grounding type plug that has a third (grounding) pin. This plug will only fit into a grounding type outlet. If the plug does not fit into the outlet, contact a qualified electrician to install the proper outlet. Do Not change the plug in any way. The door operator must be properly grounded to prevent personal injury and damage to the components. The ELECTRICAL POWER to the door operator MUST BE TURNED OFF when power head cover is removed. Electrical power must remain off while making electrical connections.

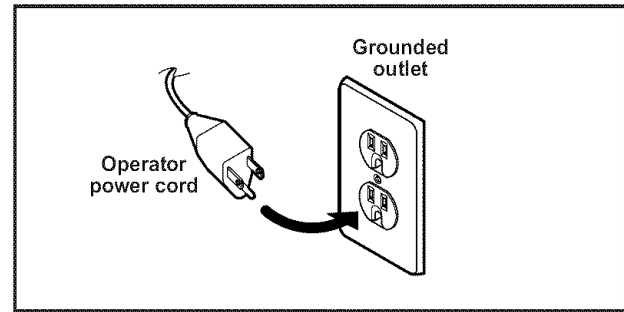

Fig. 5-1

1. **Check local building codes.**
  - Some building codes require direct wiring to a branch circuit. If direct wiring is NOT required, plug door operator into grounded outlet (Fig. 6-1).
2. **Return to Section 3 for SAFE-T-BEAM® System alignment and troubleshooting.**

*NOTE: If permanent wiring is required, have a professional electrician install circuit and wire door operator.*

### PERMANENT WIRING INSTRUCTIONS FOR ELECTRICIAN

1. **Disconnect the power cord from the branch circuit mains.**
2. **Remove bottom cover from power head.**
  - Remove four (4) hex head screws from front and rear covers.
  - Slide bottom cover off.
3. **Remove existing power cord from power head.**
  - Disconnect three power cord wires.
  - Remove and discard power cord.
  - Remove 7/8" diameter knock-out plug.
  - Install a suitable entrance bushing.
4. **Install permanent wiring to power head.**

**For Stealth—connect permanent wiring to internal terminal block.**

  - Connect white supply line to silver terminal.
  - Connect black supply line to brass terminal.
  - Connect ground wire to green wire location (GROUND).

**For ProMax—connect permanent wiring.**

  - Make connections with UL recognized wire nuts.
  - Connect white supply line to white wire.
  - Connect black supply line to black wire.
  - Connect ground wire to green wire location (GROUND).
  - Wires inside operator are to be a minimum of 6 inches.
5. **Replace power head bottom cover.**
  - Replace and tighten four (4) hex head screws.

*NOTE: Circuit boards are light sensitive. Make sure cover is on power head before operation.*

## 6... MAIN LIMIT SWITCH SETTINGS

FOR HELP-1.800.354.3643 OR GENIECOMPANY.COM

22

### **WARNING**

Door opens rapidly.

- Keep path clear.
- Position ladder to the side of power head so it is clear of all moving parts of door and operator.

Set door operator so minimum force is needed to operate door.

Before starting main limit switch settings, LOCK carriage onto rail assembly (See emergency release tag).

1. Raise the door until the carriage engages with the inner-slide/bullet.
2. Set "OPEN" limit switch (Fig 6-1).
  - Locate limit set switch on back of power head.
  - Push and hold limit set switch until door moves to the fully open position.
    - release the limit set switch.
    - "OPEN" limit switch is set.

*NOTE: If door stops and refuses to move up, adjust "OPEN FORCE" (See Section 7-FORCE ADJUSTMENT) and then repeat setting limit switch.*

3. Set "CLOSE" limit switch (Fig. 6-1).
  - Push and hold limit set switch until door contacts the ground and stops.
    - release limit set switch.
    - "CLOSE" limit is set.

*NOTE: If door stops and refuses to move down, adjust "CLOSE FORCE" (See Section 7-FORCE ADJUSTMENT) and then repeat setting limit switch.*

*NOTE: Do Not push the limit set switch again, your limits are set. Slight adjustment may be needed later (See Section 8-FINE LIMIT SWITCH ADJUSTMENTS).*

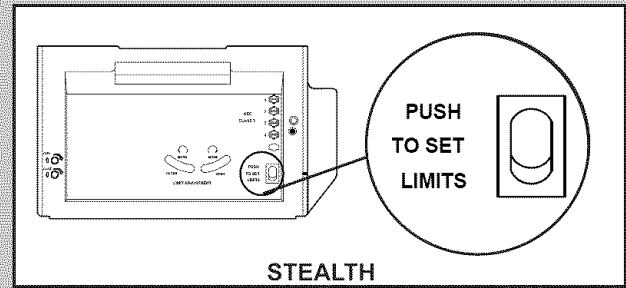

STEALTH

OR

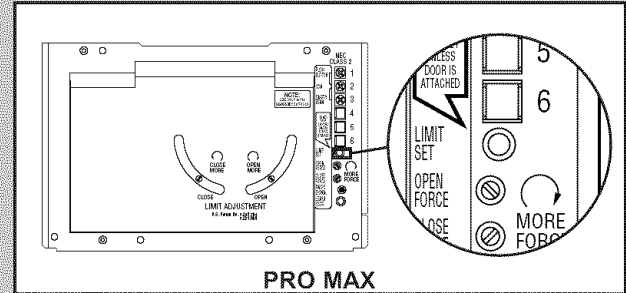

PRO MAX

Fig. 6-1

## 7... FORCE ADJUSTMENT

FOR HELP-1.800.354.3643 OR GENIECOMPANY.COM

### **WARNING**

Adjust your door operator so that minimum force is needed to operate door.

Position ladder to the side of the power head so that it is clear of all moving parts of the power head, rail assembly and door.

During the following steps, the motor protector may open. Wait about 20 minutes for protector to reset.

*NOTE: Use wall control to run door to the fully CLOSED position before starting "OPEN FORCE" adjustment.*

#### 1. Adjust the "OPEN" Force (Fig. 7-1).

- Locate screw on back of power head marked "OPEN FORCE."
- Gently turn screw counterclockwise until it stops.

*NOTE: Little effort is required to turn adjusting screw.*

- Operate door using wall control.
- If door does not completely open, turn "OPEN FORCE" screw clockwise slightly.
- Activate door using wall control.
- Repeat force adjustment until door will completely open.

*NOTE: Set minimum force required to make door open.*

- Close door, use wall control.

#### 2. Adjust the "CLOSE FORCE" (Fig. 7-1). Use wall control to run door to the fully OPEN position before starting "CLOSE FORCE" adjustment.

- Locate screw on back of power head marked "CLOSE FORCE."
- Gently turn screw counterclockwise until it stops.

*NOTE: Little effort is required to turn adjusting screw.*

- Operate door using wall control.
- If door does not completely close, turn "CLOSE FORCE" screw clockwise slightly.
- Operate door using wall control.
- Repeat force adjustment until door will completely close.

*NOTE: Set the minimum force required to make the door close. Smaller the number the smaller the force.*

#### 3. **CONTACT REVERSE** (Fig. 7-2)

Fine adjustments for limit switches (see Section 8) **MUST BE** completed before starting **CONTACT REVERSE**.

- Open door, use wall control.
- Place a 2 by 4 board laid flat in center of doorway.
- Close door.
- Door **MUST** stop and reverse to open position. If it does not, repeat fine adjustments for down limit switch and "CLOSE FORCE" adjustment until the door will reverse to the open position.

*NOTE: Set minimum force required to make door close. If door does not reverse, decrease "CLOSE FORCE" until door reverses.*

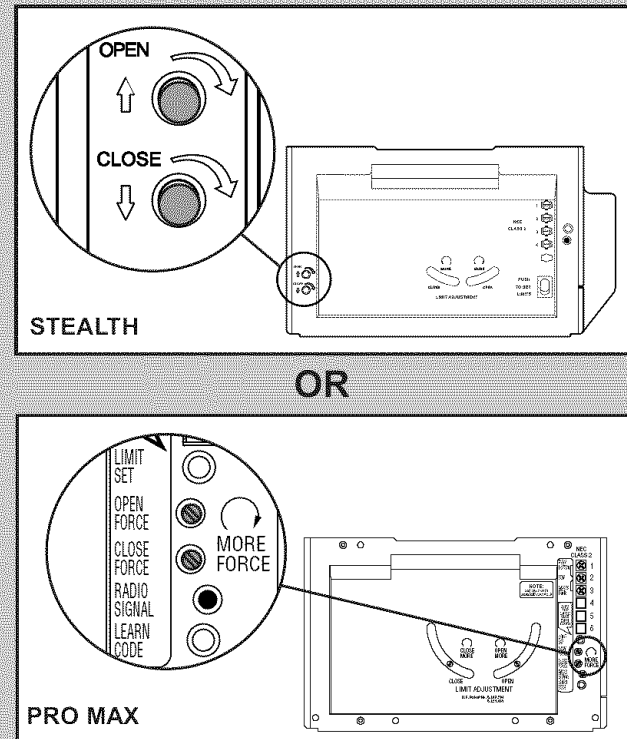

Fig. 7-1

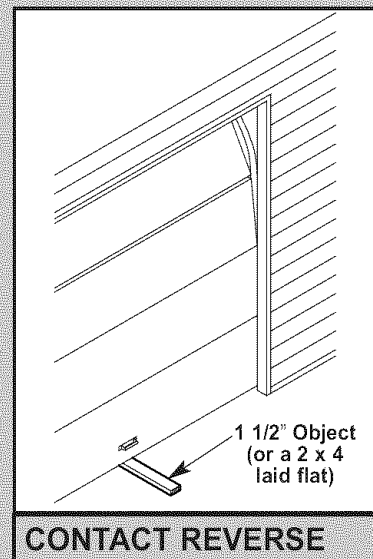

Fig. 7-2



## 8... FINE LIMIT SWITCH ADJUSTMENT

FOR HELP-1.800.354.3643 OR GENIECOMPANY.COM

24

During the following steps, the motor protector may open. Wait about 20 minutes for protector to reset.

1. **Adjusting the "OPEN" limit switch (Fig. 8-1).**
  - Run door to open position by pushing wall control.
  - Locate curved "OPEN" limit adjustment slot on back of power head.
  - Look into slot for pinion screw.
  - Insert a screwdriver and turn pinion screw.
    - clockwise to open more.
    - counterclockwise to open less.
2. **Test door operator.** Use wall control to run door open and close.
3. **Repeat step as necessary to properly set "OPEN" limit switch.**
4. **Adjust the "CLOSE" limit switch (Fig. 8-1).**
  - Run door fully closed by pushing wall control.
  - Locate curved "CLOSE" limit adjustment slot on back of power head.
  - Look into slot for pinion screw.
  - Insert a screwdriver and turn pinion screw.
    - counterclockwise to close more.
    - clockwise to close less.
5. **Test door operator.** Use wall control to run door open and close
6. **Repeat step as necessary to properly set "CLOSE" limit switch**
7. **Perform CONTACT REVERSE**

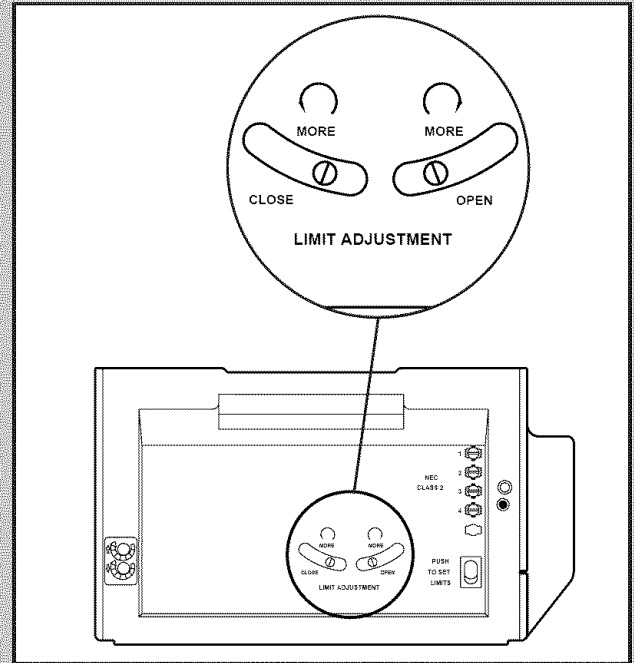

Fig. 8-1

Actual picture may vary by model

## 9... REMOTE CONTROLS

### ⚠ WARNING

Moving door can cause serious injury or death

- Keep people clear of opening while door is moving.
- Do Not allow children to play with remote controls.

If safety reverse does not work properly:

- Close door and disconnect operator using emergency release.
- Do not use door operator or remote controls
- Refer to door and door operator owner's Manuals before attempting any repairs

*NOTE: Factory sets different codes for each remote control.*

*Remote controls will not work if STB's malfunction*  
*When programming remote control keep at least 24 inches away from antenna.*

1. **Program one-button remote (Fig. 9-1)**
  - Locate learn code button and learn indicator on power head.
    - Remove lens cover on back of power head.
  - Press and release learn code button on power head.
    - LED on power head blinks 2 times per second.

(continued on next page)



One-Button Remote Control\*

Multi-Button Remote Control\*

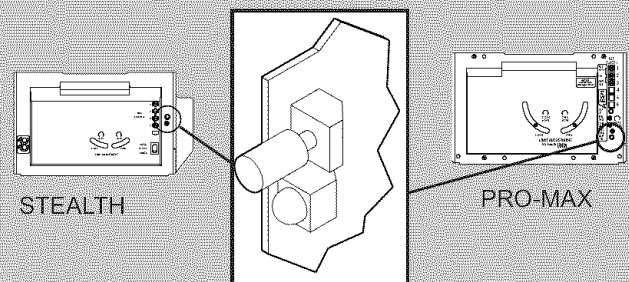

Fig. 9-1

\* Remotes vary depending on model. Your operator will have one or the other.



- Press and release a remote control button.
  - LED on power head stops blinking.
- Press and release same remote button again.
  - LED goes out. Remote is now programmed.

**2. Program multi-button remote control**

- Repeat step 1 (“program one-button remote” for each button).

*NOTE: Each button on a multi-button remote control is for a different operator.*

**3. Operate remote control**

- Point remote control at door
  - Door moves
- Press button again
  - Door stops
- Press button again
  - Door reverses

*NOTE: Door automatically stops at end of open or close cycle.*

**4. Erasing all receiver memory**

- Press and hold learn code button on power head
  - 10 seconds or until light goes out
  - Memory is erased
- Program door operator again
- Press remote control button once within 30 seconds
  - LED on power head stays lit
- Press remote control button again
  - LED on power head goes out and remote control is programmed

*NOTE: If LED blinks approximately 4 times per second, programming has stopped. If programming stops, repeat above steps.*

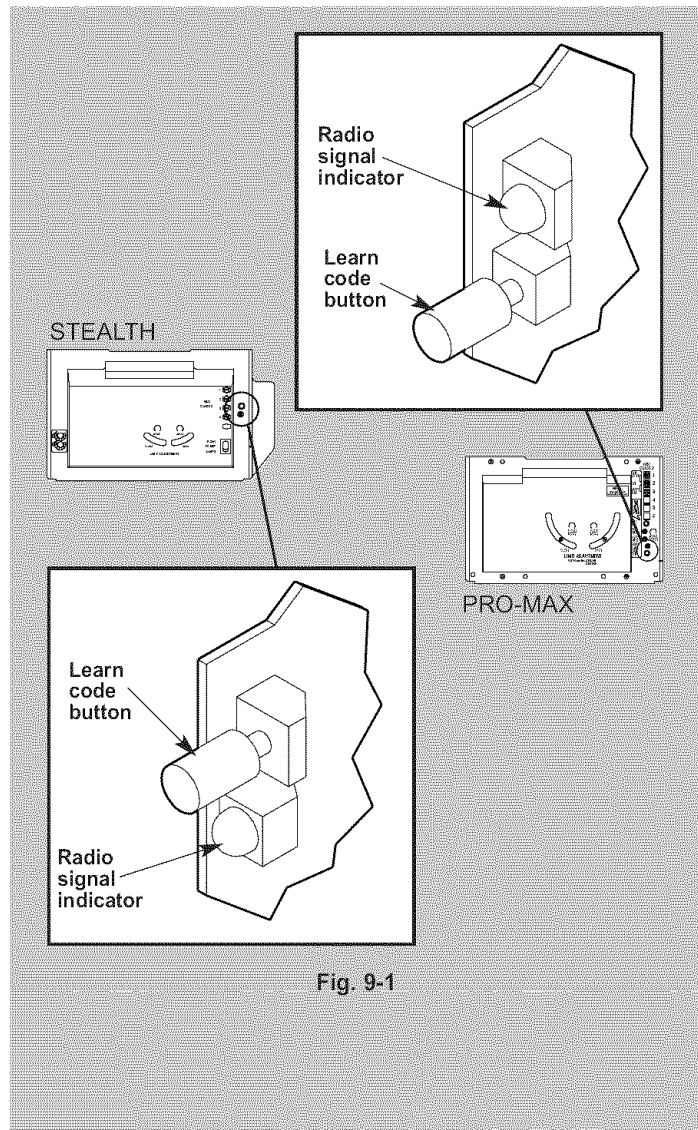

Fig. 9-1

**10.. BATTERY / VISOR CLIP INSTALLATION**

**1. Turn remote control upside down (Fig. 10-1)**

**2. Battery replacement** (your remote control is battery powered).

- Gently push straight IN on tab as shown (Fig. 10-1).
  - use ball point pen, coin or small screwdriver.
  - battery cover snaps open.
- Install new battery in same position.
  - use A23, **EVEREADY** 12 Volt battery.

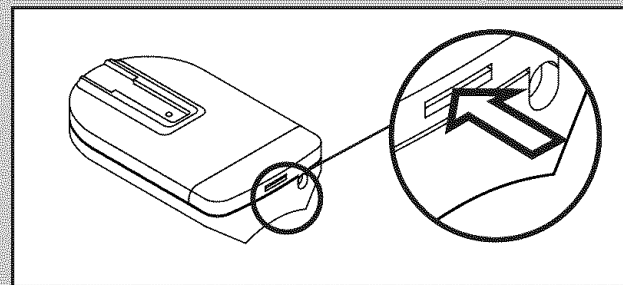

Fig. 10-1

**3. Attach visor clip to remote control (Fig. 10-2)**

- Slide visor clip into back of case until it snaps into place.

**4. Remote control operation**

- Point remote control at the garage door and press the button. Door will move.
- Press remote control button again and door will stop.
- Press remote control button again and the door will move the other way. The door automatically stops at the end of the open or close cycle.

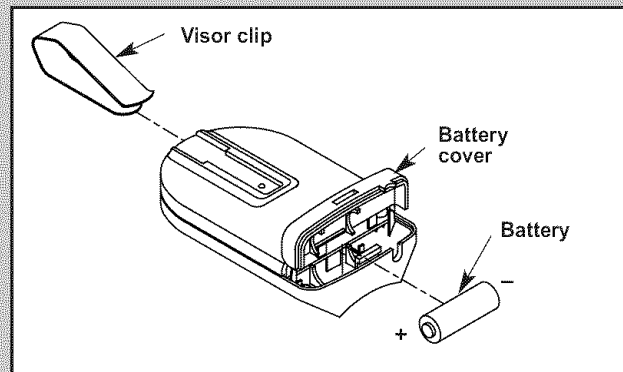

Fig. 10-2

1. **Install light bulb(s) into socket(s).**  
**Do Not** use short neck bulb(s).
  - Use bulb(s) rated for:
    - rough service.
    - vibration.
    - appliances.
  - 100 watt maximum.
2. **Bend two (2) slotted tabs up. This will activate the "living hinge" of the lens (Fig. 11-1).**

*NOTE: The following steps use the screws from the Blue Parts Bag that were set aside earlier.*

3. **Start two (2) No. 8 x 3/4" hex head screws into bottom holes of panel (Fig. 11-2).**
  - Slide slotted tabs up behind hex head screws.
  - Tighten hex head screws.
4. **Align lens holes and holes of panel.**
  - Insert and tighten a No. 8 x 5/8" pan head screw into each round lens hole and tighten,

*NOTE: Screw heads fit completely into recess of lens tab.*

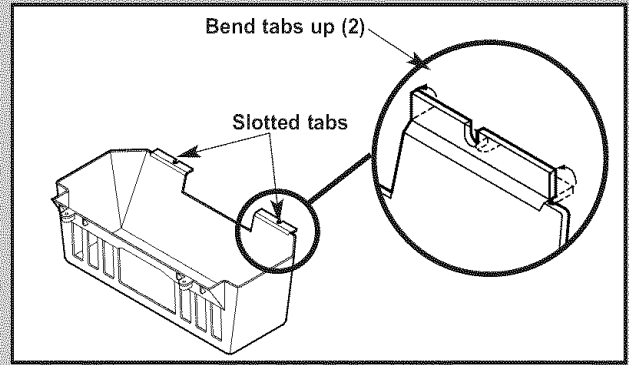

Fig. 11-1

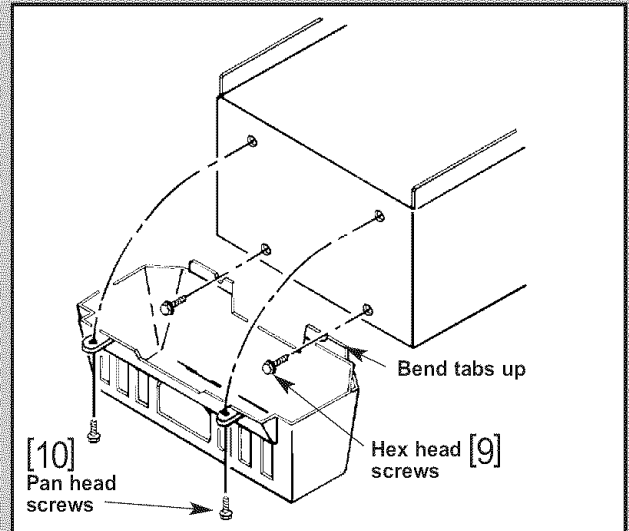
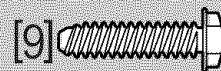

Fig. 11-2



Hex Head Screw  
No. 8 x 3/4"



Pan Head  
Phillips Screw  
No. 8 x 5/8"

**MONTHLY MAINTENANCE**

**DOOR SPRINGS and DOOR HARDWARE**

- Do not operate garage door automatically or manually if springs are broken. CONTACT A PROFESSIONAL FOR SERVICE.
- Oil door rollers, bearings, and hinges monthly. Use silicone lubricant or light oil.

**DOOR BALANCE**

- Close door. Pull red emergency release knob down and toward power head to release door from rail assembly.
- Raise door manually approximately 3 feet. Door should stay in that position. If door moves, HAVE DOOR SERVICED BY A PROFESSIONAL.
- Close door. Pull red emergency release knob to reattach door to rail/channel assembly.

**CONTACT REVERSE**

- Close door on a 2 by 4 board laid flat on the floor in the center of the garage doorway.
- Close door by using wall button or remote control.
- If door fails to reverse on contact with the board, see Section 7-CONTACT REVERSE.
- If operator still fails, replace operator or HAVE THE DOOR SERVICED BY A PROFESSIONAL.

**Safe-T-Beam® STB SYSTEM**

- Use self-diagnostic Safe-T-Beam® System troubleshooting information to maintain safe operation. (See Section 3-STB SYSTEM INSTALLATION.)

**IMPORTANT SAFETY INSTRUCTIONS**

**⚠ WARNING**

**To reduce the risk of severe injury or death:**

- 1 READ AND FOLLOW ALL INSTRUCTIONS.
- 2 Never let children operate or play with the Door Controls. Keep the Remote Control away from children.
- 3 Always keep the moving door in sight and away from people and objects until the door is completely closed. NO ONE SHOULD CROSS THE PATH OF THE MOVING DOOR.
- 4 NEVER GO UNDER A STOPPED, PARTIALLY OPEN DOOR.
- 5 Test Opener monthly. The door MUST reverse on contact with a 1-1/2" high object (or a 2" x 4" board laid flat) at the center of the doorway on the floor. After adjusting either the Force or the Limit of travel, retest the Door Opener. Failure to adjust the Opener properly may cause severe injury or death.
- 6 When possible use the Emergency Release only when the door is closed. Use caution when using this Release with the door open. Weak or broken springs are capable of increasing the rate of door closure and increasing the risk of severe injury or death.
- 7 KEEP GARAGE DOORS PROPERLY BALANCED. See Owner's Manual. An improperly balanced door increases the risk of severe injury or death. Have a Genie Factory Authorized Dealer make repairs to cables, spring assemblies, and other hardware.
- 8 **SAVE THESE INSTRUCTIONS.**

**Transmitter Compliance Statement**

Transmitters comply with all United States and Canadian legal requirements as of the date of manufacture. No warranty is made that they comply with all legal requirements of any other jurisdiction. If transmitters are to be used in another country, the importer must determine compliance with any local laws and regulations which may differ from United States and Canadian requirements prior to use.

Los transmisores cumplen con todas las reglamentaciones legales de los Estados Unidos y del Canadá, en la fecha de fabricación. Ninguna garantía se da que cumplan con todas las reglamentaciones legales de ninguna otra jurisdicción. Si los transmisores se van a utilizar en otros países, el importador debe determinar si cumplen con las reglamentaciones y leyes locales que puedan ser diferentes a las reglamentaciones de los Estados Unidos y del Canadá, antes de usar los mismos.

Les metteurs sont conformes à la réglementation américaine et canadienne compter de leur date de fabrication. Aucune garantie n'est stipulée indiquant qu'ils sont conformes toutes les prescriptions juridiques d'autres autorités. Si les metteurs sont utilisés dans d'autres pays, l'importateur doit en déterminer leur conformité aux lois et règlements locaux pouvant différer de celles des États-Unis et du Canada avant toute utilisation desdits metteurs.

Sendeger te entsprechen allen gesetzlichen Bestimmungen in den USA und Kanada zum Zeitpunkt der Herstellung. Wir übernehmen keine Gewährleistung für die Einhaltung aller gesetzlichen Bestimmungen in anderen Ländern. Sollen Sendeger te in anderen Ländern eingesetzt werden, so muss der Importeur vor dem Gebrauch sicherstellen, dass die Sendeger te auch solchen lokalen Bestimmungen entsprechen, welche von den Bestimmungen der USA und Kanadas abweichen.

截止于制造日期·传动装置符合美国和加拿大的所有法律要求。不提供传动装置符合任何其他司法地区所有法律要求之担保。如果传动装置需在任何其他国家使用,进口商必须在使用之前确定装置符合与美国和加拿大要求不同之所有地方法规条例。

トランスミッターは、製造日付けのアメリカ合衆国及びカナダの法的条件に準拠します。しかしながら、トランスミッターがアメリカ合衆国及びカナダ以外の国の法的条件に準拠するかどうかは一切保証できません。トランスミッターがアメリカ合衆国及びカナダ以外の国で使用される場合、同製品の使用に先立つ法規制がこれらの国々と異なることがあるため、輸入者は同製品が輸入国の法規制に準拠することを確認しなければなりません。

트랜스미터들은 미국과 캐나다 전역에서 제조 날짜를 명기해야 하는 요구사항에 따라야 합니다. 기타 다른 관할권의 모든 법적인 요구 사항에 따라야 하는 책임은 없습니다. 만일 트랜스미터들이 기타 다른 지역에서 사용될 경우 수입업자는 사용하기에 앞서 미국과 캐나다와의 요구사항과는 다를지도 모르는 그 지역의 법과 조례에 따라야 할지의 여부를 결정해야 합니다.

Use this guide to correct problems with your door operator. If these solutions **do not** work, call Customer Service.

**⚠ CAUTION**

Use only with included **SERIES II** wall control  
Use of any other wall control can cause the door to operate unexpectedly and the light not to work.

PROBLEM	SOLUTIONS
Operator does not run from wall control.	<p>Check lock switch on wall console (See section 4).</p> <p>Check the power source.</p> <ul style="list-style-type: none"> <li>• Plug a lamp into outlet used for power head. If lamp works, power source is OK. If not, check fuse or circuit breaker.</li> <li>• If power is OK:                             <ul style="list-style-type: none"> <li>- Check connections at power head terminals.</li> <li>- Check connections at wall control.</li> <li>- Motor protector may be open. Wait about 20 minutes for protector to reset.</li> </ul> </li> </ul>
Door starts for no reason.	<p>Check staples on wire from power head to wall control. If they cut into insulation, they can short wires. If wire is cut, replace it.</p> <p>Was a remote control lost or stolen? Erase all remote control codes from receiver memory and reprogram.</p> <p>Wall control button sticking. Check operation of buttons.</p>
Door starts down, then stops before it's closed.	<p>Check CLOSE limit switch setting (See Section 8)</p> <p>Check for shorted wires</p>
Door starts down, then stops and goes back up.	<p>Check force adjustment (See Section 7).</p> <p>Check CONTACT REVERSE (See Section 7).</p> <p>Check for light beam obstruction or misalignment of Safe-T-Beam® (See Section 3).</p> <p>Check STB self-diagnostic code.</p>
Door will only run closed.	<p>Check OPEN limit switch for short and proper wiring.</p> <p>Check force adjustment (See section 7).</p> <p>Check for broken door spring.</p>
Door will only run open.	<p>Check Safe-T-Beam® System(See section 3).</p> <p>Check CLOSE limit switch for short and proper wiring.</p> <p>Check force adjustment (See Section 7).</p>
Remote control has less than 25 feet operating range.	<p>Relocate remote control inside car.</p> <p>Point remote control at door.</p> <p>Replace battery.</p> <p><b>Do Not</b> attempt to retune remote controls.</p>
Door starts up, but stops before it's completely open.	<p>Be sure door is in good repair, properly lubricated and balanced.</p> <p>Check OPEN limit switch setting (See section 8).</p> <p>Check force adjustment (See section 7).</p> <p>Check for broken door spring.</p>
Operator runs, but door does not move.	<p>Make sure carriage is engaged.</p> <p>Check force adjustment (See Section 7).</p>
Operator works from wall control, but not from remote control.	<p>Program remote control code into receiver memory (See section 9).</p> <p>If one remote control works and another does not, check battery, remote control type (Series II) and frequency of non-working unit (See section 9) .</p>
Noisy operation.	<p>Be sure all fasteners are tight.</p> <p>Be sure door is in good repair, properly lubricated and balanced (See Monthly Maintenance section).</p>
STB System malfunction.	<p>Use self-diagnostic STB System troubleshooting information to maintain safe operation (See section 3).</p>
Lights will not go out.	<p>Check wiring.</p> <p>Disconnect &amp; reconnect wires on wall control.</p> <p>Non-compatible wall control.</p>
Innerslide jammed into power head.	<p>Remove motor cover and rotate opti-wheel.</p>



**CAUTION**

Opening cover could cause electrical shock.

(Stealth Motor)

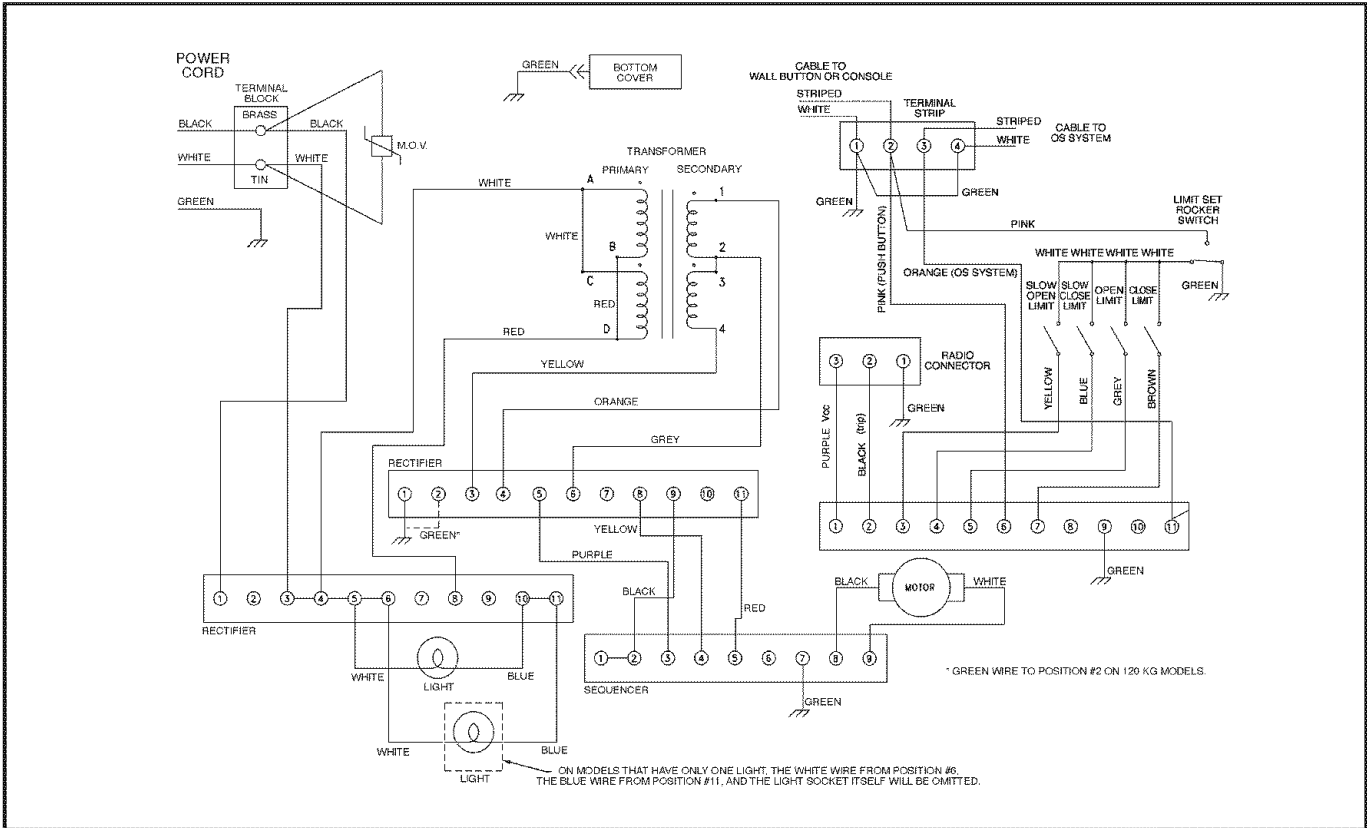



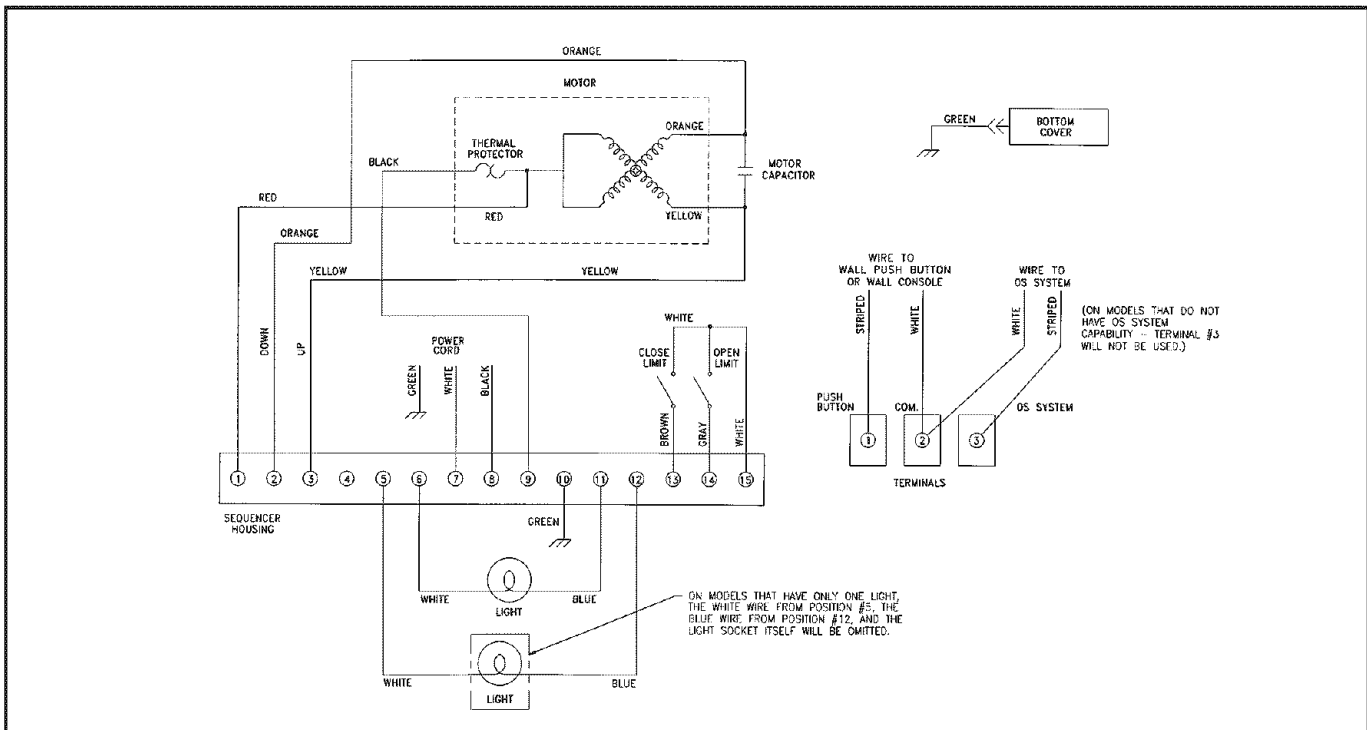







(ProMax Motor)

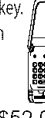

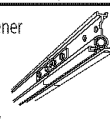
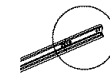
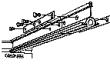

30

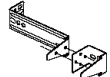
	How many? ¿Cuántos? Comment beaucoup?
<p><b>(GIT-1) 1-Button Remote Control with Intellicode®</b> - Allows remote operation of garage door. <b>Controlador remoto de lujo con Intellicode®</b> - Proporcionar operación remoto de la puerta del garaje. <b>Télécommande de luxe avec Intellicode®</b> - Permettre opération éloigné de porte de garage. P/N 33069R \$36.50</p> 	
<p><b>(GIT-2) 2-Button Remote Control with Intellicode®</b> - Allows remote operation of 2 garage doors. <b>Controlador remoto de 2 funciones con Intellicode®</b> - Proporcionar operación remoto de dos las puertas del garaje. <b>Télécommande à 2 fonctions avec Intellicode®</b> - Permettre opération éloigné deux portes de garage. P/N 33069S \$45.00</p> 	
<p><b>(GIT-3) 3-Button Remote Control with Intellicode®</b> - Allows remote operation of 3 garage doors. <b>Controlador remoto de 3 funciones con Intellicode®</b> - Proporcionar operación remoto de tres las puertas del garaje. <b>Télécommande à 3 fonctions avec Intellicode®</b> - Permettre opération éloigné trois portes de garage. P/N 33069T \$50.00</p> 	
<p><b>(GPWC-2WLB) Lighted Wall Console</b> - Operates Garage Door. Independent light control. Security vacation lock. <b>Consola de pared de 3 funciones</b> - Acciona la puerta del garaje. Control de luz independiente. Cerradura de seguridad para vacaciones. <b>Console murale à trois fonctions</b> - Actionne la porte de garage. Commande d'éclairage indépendante. Interrupteur de verrouillage de sécurité. P/N 34292R \$16.18</p> 	
<p><b>(GMI-3) 3-Button Mini Remote Control with Intellicode®</b> - Fits easily into pocket or purse. <b>Minicontrolador remoto de 3 funciones con Intellicode®</b> - Cave fácilmente en el bolsillo o cartera. <b>Mini télécommande à 3 fonctions avec Intellicode®</b> - se glisse dans la poche de veston ou le sac à main. P/N 34901R \$40.00</p> 	
<p><b>(GWKP) Wireless Keypad Entry System</b> - Operates Intellicode® Garage Door Openers without Remote Control or key. <b>Sistema de entrada por teclado numérico inalámbrico</b> - Acciona los abridores de puertas de garaje Intellicode® sin control remoto o llave. <b>Système d'ouvre-porte de garage à clavier sans fil</b> - Actionne les ouvre-porte de garage avec Intellicode® sans télécommande ni clé. P/N 35282R \$52.00</p> 	
<p><b>(GLU-3) 1/4 oz. Tubes Screw Drive Lubricant (3)</b> - Ensures proper equipment wear protection. <b>1/4 once Lubricante de tornillo accionar (3)</b> - Asegura componente correcto protección por deterioro. <b>La onza 1/4 Lubricante de la vis (3)</b> - Garantir component exact par système défense vers user. P/N 35164R \$5.00</p> 	
<p><b>(GWB) Universal Wall Button</b> - Provides additional convenient inside operation of door. <b>Botón de pared universal</b> - Proporciona operación conveniente de la puerta desde el interior. <b>Bouton mural universel</b> - Actionne l'ouvre-porte de l'intérieur du garage. P/N 34960R \$3.75</p> 	
<p><b>(GPS-5) Perfect Stop®</b> - Ensures perfect parking. <b>Stop Perfecto®</b> - Asegura el estacionamiento perfecto. <b>Butoir Perfect Stop®</b> - Permet de stationner à la perfection dans le garage. P/N 34964R \$4.00</p> 	
<p><b>(GSXL-8) Excelsior Screw Drive Extension Kit</b> - An Extension that increases the travel of a Screw Drive Opener to accommodate an eight foot door. <b>El extensión deslizante de Excelsior Screw Drive</b> - Una extensión para aumentar la carrera de un abridor deslizante de tornillo, para acomodar una puerta de 8 pies (2,43 m). <b>Nécessaire de rallonge du Excelsior Screw Drive</b> - Rallonge de prolongeant la course de l'ouvre-porte Screw Drive pour une porte de 2,4 m (8 pi) de hauteur. P/N 33523R \$31.15</p> 	
<p><b>(LCGX-8) Chain Glide™ Extension Kit</b> - An Extension that increases the travel of a Chain Glide Opener to accommodate an eight foot door. <b>Juego de extensión de cadena deslizante</b> - Una extensión para aumentar la longitud de la baranda de Chain Glide, para acomodar una puerta de 8 pies (2,43 m). <b>Nécessaire de prolongement du coulisseau</b> - Rallonge de prolongeant la course de l'ouvre-porte Chain Glide pour une porte de 2,4 m (8 pi) de hauteur. P/N 00001085 \$30.00</p> 	
<p><b>(GSX-8) Screw Drive Extension Kit</b> - Eighteen inch Extension to increase travel of Screw Drive Operator to accommodate eight foot door. <b>Juego de extensión deslizante de Screw Drive</b> - Una extensión de 18 pulgadas para aumentar la carrera de un abridor deslizante de tornillo, para acomodar una puerta de 8 pies (2,43 m). <b>Nécessaire de rallonge du Screw Drive</b> - Rallonge de 30 dm (18 po) prolongeant la course de l'ouvre-porte Screw Drive pour une porte de 2,4 m (8 pi) de hauteur. (GIRU-1T) Universal Conversion Kit - Converts any Garage Door Opener to a secure radio signal system. Kit includes a Remote Control, Receiver and Transformer. P/N 33523S \$36.35</p> 	
<p><b>(60 WATT) Enhanced/Rough Service Light Bulb</b> - Ensures proper equipment compatibility <b>Bombilla de 60 Vatios</b> - Asegura componente correcto de sistema <b>Éclairage de 60 WATT</b> - Garantir component exact par système P/N 26210A.S \$2.73</p> 	
<p><b>(GER-2) Emergency Release Kit</b> - Provides access to garage from outside in the event of an electrical power failure <b>Juego de pica-porte de pestillo</b> - Permitir entrada desde por fuera de garaje porque corte de eléctrico <b>Nécessaires de Déclenchement de secours</b> - Le nécessaire de déclenchement de secours est conçu pour vous permettre d'accéder à votre garage depuis l'extérieur en cas de panne de courant et lorsqu'il P/N 34963R \$20.00</p> 	
<p><b>STB Adapter Brackets (2)</b> - Used in conjunction with standard STB Brackets. They provide additional clearance and mounting options <b>El adaptador pone entre paréntesis (2)</b> - Usado en unión con paréntesis uniformes de montar de STB, ellos proporcionan el espacio libre adicional junto con montar las opciones <b>Crochets d'adaptateur (2)</b> - Utilisé conjointement avec STB standard monter les crochets, ils fournissent le dégagement supplémentaire avec monter d'options P/N 34439R.S \$4.37</p> 	

## Ordering Instructions

No C.O.D. shipments. Please include check or money order, made payable to The Genie Company. **Do not send cash.** Allow 3-4 weeks for delivery. 1-800-354-3643. Please have part number and credit card ready. Mail Order Form to: **Genie Company, Alliance, Ohio 44601.** We accept Visa or Mastercard on phone orders only.

Please add local sales tax if you reside in one of the states listed. California, Connecticut, Florida, Georgia, Illinois, Indiana, Maryland, Massachusetts, Michigan, New Jersey, New York, Ohio, Tennessee, Virginia, Wisconsin

TOTAL ORDER	\$
SHIPPING & HANDLING	\$ 5.00
STATE SALES TAX	\$
GRAND TOTAL	\$

## Las Instrucciones que Ordenan

No se aceptan pedidos de pago contra entrega (COD). Sirvase incluir su cheque o giro postal, la cuenta pagadera hecha a The Genie Company. **No envíe dinero en efectivo.** Concédanos 3 a 4 semanas para la entrega. 1-800-354-3643. Sirvase tener listos los números del modelo y de la tarjeta de crédito. Enviar hacer un pedido de mercancía a: **Genie Company, Alliance, Ohio 44601.** Aceptamos pedidos telefónicos de Visa o Mastercard.

Sirvase agregar el impuesto de ventas local si usted reside en uno de los siguientes estados:

California, Connecticut, Florida, Georgia, Illinois, Indiana, Maryland, Massachusetts, Michigan, New Jersey, New York, Ohio, Tennessee, Virginia, Wisconsin

TOTAL DEL PEDIDO	\$
FLETE Y MANEJO	\$ 5.00
IMPUESTO DE VENTAS ESTATAL	\$
GRAN TOTAL	\$

## Instructions Commandant

Pas d'expédition contre remboursement. Veuillez inclure un chèque ou un mandat bancaire, le payable fait à The Genie Company. **N'envoyez pas d'argent comptant.** Accordez de 3 à 4 semaines pour la livraison. 1-800-354-3643. Ayez sous la main le numéro de la pièce et celui de la carte de crédit. Mettre à la poste le arrangement à: **Genie Company, Alliance, Ohio 44601.** Nous acceptons les commandes par téléphone avec paiement par carte de crédit Visa ou Mastercard.

Veuillez indiquer les taxes de vente locales si vous résidez dans l'un des états répertoriés ci-dessous.

California, Connecticut, Florida, Georgia, Illinois, Indiana, Maryland, Massachusetts, Michigan, New Jersey, New York, Ohio, Tennessee, Virginia, Wisconsin

COMMANDE TOTALE	\$
MANUTENTION ET EXPÉDITION	\$ 5.00
TAXE DE VENTE	\$
TOTAL GLOBAL	\$

SHIP ORDER TO:  
ENVIAR MERCANCIA CON:  
EXPÉDIER MARCHANDISE POUR:

NAME / NOMBRE / NOM
ADDRESS / DIRECCIÓN / ADRESSE
CITY / CIUDAD / VILLE
STATE / ESTADO / ÉTAT
ZIP / CÓDIGO POSTAL / CODE POSTAL

(Prices subject to change without notice)  
(Valorar el cambio con sujeción a sin nota)  
(Les prix assujettissent pour changer sans la notification)





## The Genie Company Professional Access Systems LIMITED WARRANTY

**What is covered:** Any defect in material and workmanship from personal, normal household use in accordance with the Owner's Manual  
**For how long:**

- 300 Series - Motor 5 years and all other parts 3 years.
- 500 Series - Motor Lifetime\* and all other parts 5 years.
- 1200 Series - Motor Lifetime\* and all other parts 5 years.

*\*Lifetime warranty = warranted for as long as you own your home.*

**Who gets the warranty:** This warranty is limited to the consumer who originally purchased the product.

**Geographic scope:** This warranty applies only to Genie products purchased in the United States, Canada or Mexico.

**What we will do:** If your Genie product is defective, we will repair it or, at our option, replace it at no charge to you. If we repair your Genie product, we may use new or reconditioned replacement parts. If we choose to replace your Genie product, we may replace it with a new or reconditioned one of the same or similar design.

**Limitations:** IMPLIED WARRANTIES, INCLUDING THOSE OF FITNESS FOR A PARTICULAR PURPOSE AND MERCHANTABILITY (AN UNWRITTEN WARRANTY THAT THE PRODUCT IS FIT FOR ORDINARY USE), ARE LIMITED TO ONE YEAR FROM THE DATE OF PURCHASE. GENIE WILL NOT PAY FOR: LOSS OF TIME; INCONVENIENCE; LOSS OF USE OF YOUR GENIE PRODUCT OR PROPERTY DAMAGE CAUSED BY YOUR GENIE PRODUCT OR ITS FAILURE TO WORK; ANY SPECIAL, INCIDENTAL OR CONSEQUENTIAL DAMAGES; OR ANY DAMAGES RESULTING FROM MISUSE OR MODIFICATION OF YOUR GENIE PRODUCT.

Some states and provinces do not allow limitations on how long an implied warranty lasts or the exclusion of incidental or consequential damages, so the above exclusions may not apply to you.

**How to obtain warranty service:** To obtain warranty service for your Genie product, you must provide proof of the date and place of purchase of the product.

1. **Do-It-Yourself-Service.** Call the Genie Consumer Connection toll free at 1-800-354.3643 a Trained Genie representatives will assist you in diagnosing the problem and will arrange to supply you with the required parts for do-it-yourself repairs. Trained service representatives are available Monday-Friday, 8:00 a.m. - 8:00 p.m., Eastern Time, and on Saturday, 11:00 a.m. to 5:00 p.m., Eastern Time (subject to holidays).
2. **Service From Authorized Dealers.** You also may obtain warranty service by calling the Genie Consumer Connection at 1.800.654.3643 before reaching any agreement on service. If warranty service is provided by an authorized dealer, Genie will provide all required parts under warranty at no charge to you, but the dealers are independent business people and may render a bench or service call charge for their services. Genie will not reimburse you or otherwise be responsible for those charges.

We suggest that you retain your original packing material in the event you need to ship your Genie product. Be sure to include your name, address, telephone number, proof of date and place of purchase and a description of the operating problem. After repairing or, at our option, replacing, your Genie product, we will ship it to your home at no cost to you for parts and labor, but you will have to pay a minimum of \$5.00 for shipping and handling charges.

Your choice of any one of the above-described service options is your exclusive remedy under this warranty.

**What this warranty does not cover:** This warranty does not cover batteries (which are considered replaceable parts), installation, commercial use, defects resulting from accidents, damage while in transit to our service location or damage resulting from alterations, misuse or abuse, lack of proper maintenance, unauthorized repair or modification of the product, affixing of any attachment not provided with the product, fire, flood, or acts of God, or other failure to follow the Owner's Manual.

**This warranty is the only one we will give on your Genie product, and it sets forth all our responsibilities regarding your Genie product. There are no other express warranties.**

**State and province rights:** This warranty gives you specific legal rights, and you may also have other rights which vary from state to state and province to province.

Manufactured under one or more of the following U.S. patents: 3,898,582/4,041,259/4,048,630/4,064,487/4,103,238/5,222,403  
Other Patents applied for

**FILL THIS IN AT TIME OF INSTALLATION FOR YOUR OWN RECORDS,  
SO THAT IT WILL BE AVAILABLE IF YOU EVER NEED TO CALL US**

Date Purchased _____ / _____ / _____	Serial Number _____
Operator Model _____	Remote Control Model _____
Dealer Name _____	
Dealer Address _____	
City _____	State _____ Zip _____

CORRESPONDENCE WITH FACTORY MUST INCLUDE DATE / MFG. NO.  
(LOCATED UNDER LENS OF POWER HEAD)

Customer Service  
**1.800.35 GENIE**

Or Visit Our Website

<http://www.geniecompany.com>

**SAVE THESE INSTRUCTIONS**