

OPERATOR'S MANUAL

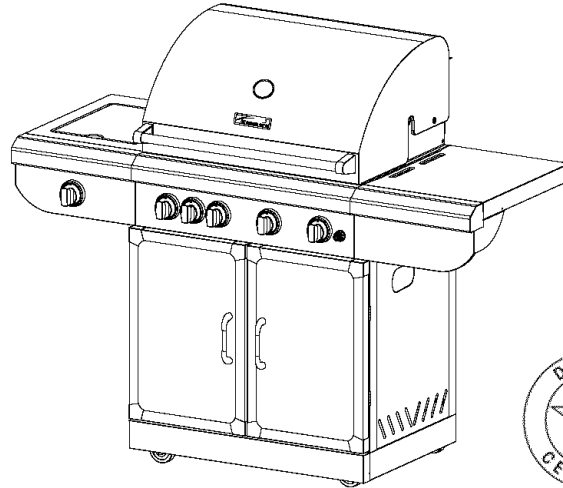

Liquid Propane Gas (LPG) Grill
Model 119.162300



- Safety
- Assembly
- Use and Care
- Cooking Guide
- Frequently Asked Questions

Customer Support Center:

Call us first if you have any problem with this product. We can help you with questions about assembly and grill operation or if there are damaged or missing parts when you unpack this unit from the carton. Please call before returning to the store.

1-800-933-0527

8:30am-5:00pm CST, Monday through Friday

IMPORTANT:

- **NOTE TO ASSEMBLER/INSTALLER:**
Leave this manual with the consumer.
- **NOTE TO CONSUMER:**
Keep this manual for future reference.
- **RECORD YOUR SERIAL#** _____
(see silver CSA label on main body of grill)
- **DATE OF PURCHASE:** _____
- **ATTACH YOUR SALES RECEIPT HERE:**



WARNING



- Failure to comply with these instructions could result in a fire or explosion that could cause serious bodily injury, death or property damage.
- Whether this grill was assembled by you or someone else, you must read this entire manual before using your grill to ensure the grill is properly assembled, installed and maintained.
- **Use your grill at least 2 feet away from any wall or surface.** Use your grill at least 2 feet away from combustible objects that can melt or catch fire (such as vinyl or wood siding, fences and overhangs) or sources of ignition including pilot lights on water heaters and live electrical appliances.
- **THIS GAS APPLIANCE IS DESIGNED FOR OUTDOOR USE ONLY.**
- Combustion byproducts produced when using this product contain chemicals known to the State of California to cause cancer, birth defects, or other reproductive harm.

Sears, Roebuck and Co., Hoffman Estates, IL 60179 U.S.A. www.sears.com

Table of Contents

Primary Safety Warnings.....	1-3
Warranty Terms and Conditions.....	2
Pre-Assembly Instructions.....	3
Part Diagram and Lists.....	4-10
Assembly Instructions.....	11-21
Regulator & Hose Instructions, Gas Tank Instructions.....	22-24
Use & Care Instructions:	
• Lighting Instructions.....	25-26
• Troubleshooting.....	27
• Cleaning and Maintenance.....	28-29
• Cooking Guide.....	30
• Frequently Asked Questions.....	31-32
• Sears Parts and Service Information	33

Warranty Information

One-Year Full Warranty on Kenmore Grill

If this grill fails due to a defect in material or workmanship within one year from the date of purchase, call 1-800-4-MY-HOME® to arrange for free repair (or replacement if repair proves impossible).

Ten-Year Limited Warranty on Stainless Steel Burners

For ten years from the date of purchase, any stainless steel burner will be replaced free of charge if it fails due to defects in material or workmanship. You will pay any labor charges if you wish to have it installed after the first year from date of purchase.

Warranty Restrictions

All warranty coverage excludes igniter batteries, grill paint loss rusting or stainless steel discoloration, which are either expendable parts that can wear out from normal use in less than a year, or are conditions that can be the result of normal use, accident or improper maintenance.

All warranty coverage is void if this grill is ever used for commercial or rental purposes.

All warranty coverage applies only if this grill is used in the United States. This warranty gives you specific legal rights, and you may have other rights which vary from state to state.

**Sears, Roebuck and Co.,
Hoffman Estates, IL 60179**



DANGER



IF YOU SMELL GAS:

1. Shut off gas to the appliance.
2. Extinguish any open flame.
3. Open lid.
4. If odor continues, keep away from the appliance and immediately call your gas supplier or your fire department.



WARNING



1. Do not store a spare LP cylinder within 10 feet (3m) of this appliance.
2. Do not store or use gasoline or other flammable liquids and vapors within 25 feet (8m) of this appliance.
3. When cooking with oil or grease, do not allow the oil or grease to get hotter than 350°F (177°C).
4. Do not leave oil/grease unattended.

Grill Installation Codes

The installation must conform with local codes or, in the absence of local codes, with either the National Fuel Gas Code, ANSI Z223.1/NFPA 54, or CAN/CGA- B149.1, Natural Gas and Propane Installation Code.

All electrical accessories (such as a rotisserie or light) must be electrically grounded in accordance with local codes, or, in the absence of local codes, with the National Electrical Code, ANSI/NFPA 70, or the Canadian Electrical Code, CSA C22.1. Keep any electrical cords and/or fuel supply hoses away from all hot surfaces.

Pre-Assembly Instructions For Your Safety



WARNING



Failure to comply with these instructions could result in a fire or explosion that could cause serious bodily injury, death or property damage.

Spiders and small insects can spin webs and nest in the grill burner tubes during transit and warehousing which can lead to a gas flow obstruction resulting in a fire in and around the burner tubes. This type of "FLASHBACK FIRE" can cause serious grill damage and create an unsafe operating condition for the user.

To reduce the chance of a FLASHBACK FIRE you must clean the burner tubes as follows before initial use. Also do this at least once a month in summer and fall or whenever spiders are active in your area, and if your grill has not been used for an extended period of time.

1. Remove the screw from the rear of each burner using a Phillips head screwdriver.
2. Carefully lift each burner up and away from the gas valve orifice.
3. Check and clean the burner tubes for insects and insect nests. A clogged tube can lead to a fire beneath the grill.
4. Refer to the figure below and perform one of these 3 cleaning methods:

- METHOD 1:** Bend a stiff wire or wire coat hanger into a small hook as shown and run the hook through the burner tube and inside the burner several times to remove debris.
- METHOD 2:** Use a bottle brush with a flexible handle and run the brush through the burner tube and inside the burner several times to remove any debris.

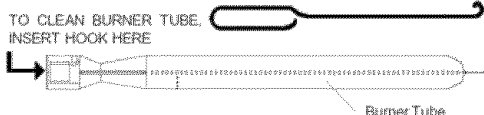

- METHOD 3:** Use an air hose to force air through each burner tube. The forced air should pass debris or obstruction through the burner and out the ports.

For safe operation ensure the gas valve assembly orifice is inside the burner tube before using your grill. See figure. If the orifice is not inside the burner tube, lighting the burner may cause an explosion and/or fire resulting in serious bodily injury and/or property damage.

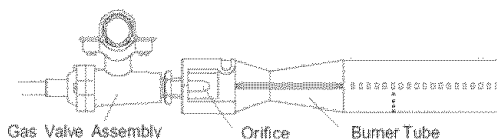

WARNING



Liquid Propane Gas (LPG) grill models must be used with the liquid propane gas regulator assembly supplied. Any attempt to convert the grill from one fuel type to another is extremely hazardous and will void the warranty.

Never use your gas grill in a garage, porch, shed, breezeway or any other enclosed area.

Never obstruct the flow of ventilation air around your gas grill cabinet.

Never disconnect the gas regulator assembly or any gas fitting while your grill is lit. A lit grill can ignite leaking gas and cause a fire or explosion which could result in property damage, personal injury or death.

Keep the gas regulator hose away from any heated surface and dripping grease. Avoid unnecessary twisting of the hose. Visually inspect the hose prior to each use for cuts, cracks, excessive wear, or other damage. If the hose appears damaged, do not use the gas grill. Call Sears at 1-800-4-MY-HOME® (1-800-469-4663) for a Kenmore replacement gas hose assembly.

PRE-ASSEMBLY

Read and perform the following pre-assembly instructions:

- Tools Required for Assembly include:**
 - protective work gloves
 - protective eyewear
 - Phillips Head Screwdriver (included in hardware pack in Parts Box)
- You will need assistance from another person to handle the grill head and other large, heavy parts.
- Open lid of shipping carton and remove parts box and packing materials. Lay a cardboard sheet on floor and use as a work surface to protect floor and grill parts from scratches.
- Slice all four corners with a utility knife to lay open the carton. This allows you to remove the grill head and components packed inside.
- Use the Hardware and Part Diagrams to ensure all items are included and free of damage.
- Do not assemble or operate the grill if it appears damaged. If there are damaged or missing parts when you unpack the shipping box or you have questions during the assembly process, call the:

Customer Support Center at 1-800-933-0527
8:30am-5:00pm CST, Monday through Friday.

Hardware Pack Parts List 119.162300

PART#	PART DESCRIPTION	QTY	PURPOSE OF PART
SB0027	Phillips Head Bolt M6x5/8"	20	Install Casters, Attaches Firebox and Cabinet Assembly.
SB0004	Phillips Head Bolt M6x3/8"	20	Attaches Cabinet Front Crossbar, Side Burner Assembly, and Side Shelf Assembly.
SB0005	Washer M6	34	There are 34 Washers in the place where the screws M6 are used
SB0009,SB0009D	Phillips Head Bolt M4x5/16"	12	Attaches Cabinet Door Shield and Control Panel to Firebox and Control Knob to Control Panel
SB0029	Flat Head Bolt M4x3/8"	8	Attaches Cabinet Doors to Cabinet
SB0016	Washer M4	6	There are 6 Washers in the place where the screws M4 are used to attaché Control Panel and Door Stopper.
FE0015	Control Knob	1	For the Side Burner
SE0007	Battery Size AA	1	For the Electronic Igniter
SE9018+FE0014	Phillips Head Screwdriver	1	To secure all of the Bolts
SB0019	Nut M5	2	Attaches Grease Pan Support to Grease Tray
SA0422	Cabinet Door Stopper	1	Secures Cabinet Door in Colsed Position

Hardware Pack Diagram for 119.162300

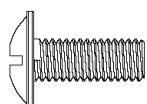

Phillips Head Bolt: M6x5/8"
Qty: 20
Part # SB0027



Phillips Head Bolt M6x3/8"
Qty: 20
Part # SB0004



Washer M6
Qty: 34
Part# SB0005



Phillips Head Bolt M4x5/16"
Qty: 12
Part # SB0009 (Black)
SB0009D (White)



Flat Head Bolt M4x3/8"
QTY: 8
Part # SB0029

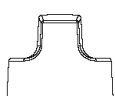

Control Knob
Qty: 1
Part # FE0015



Battery Size: AA
Qty: 1
Part # SE0007

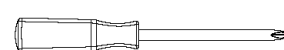

Phillips Head Screwdriver
Qty: 1
Part :# SE9018+FE0014



Washer M4
Qty: 6
Part # SB0016





Nut: M5
Qty: 2
Part # SB0019



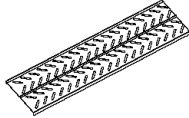

Cabinet Door Stopper
Qty: 1
Part # SA0422

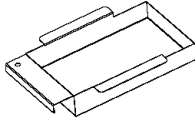
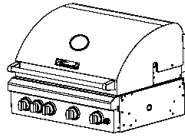
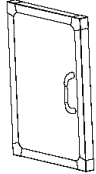
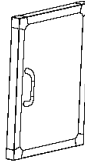
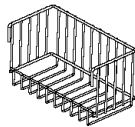
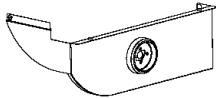

Assembly Parts List for 119.162300

Item No.	Description	Part #	Qty	Graphic
A	Cabinet Assembly	06W1C-C	1	
B	Cabinet Front Crossbar	SA0421	1	
C	Side Burner Frame	06W1C-D	1	
D	Warming Rack	SA0414	1	
E	Cooking Grate (Large -9.5" 2pc Small-7.5" 1pcs)	CI0008(Large) CI0009(Small)	3	
F	Heat Diffuser	SA0415	4	
G	Grease Pan Support	SE0077	1	

Assembly Parts List for 119.162300

Item No.	Description	Part #	Qty	Graphic
H	Grease Pan	SA0375	1	
I	Firebox Assembly	06W1C-A, 06W1C-B	1	
J	Cabinet Left Door	SA0322,SA0323, SE0087,SA0420-1	1	
K	Cabinet Right Door	SA0322,SA0323, SE0087,SA0420-1	1	
L	Condiment Basket	SE9027	1	
M	Side Burner Control Panel	SA0326, SA0423	1	
N	Side Shelf Control Panel	SA0327, SA0428	1	

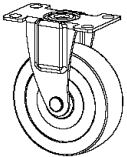
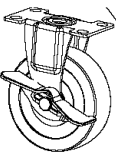
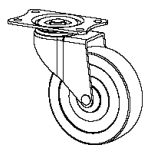
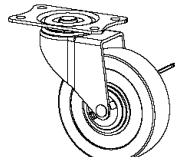
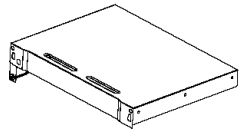
Assembly Parts List for 119.162300

Item No.	Description	Part #	Qty	Graphic
O-1	Caster	SE0056	1	
O-2	Locking Caster	SE0057	1	
O-3	Swivel Caster	SE0081	1	
O-4	Locking Swivel Caster	SE0055	1	
P	Side Shelf Assembly	06W1C-E	1	
Q	Side Burner Top Panel	SA0325,SA0423, SA0424	1	
R	Side Shelf Top Panel	SA0325,SA0427, SA0428	1	

Assembly Parts List for 119.162300

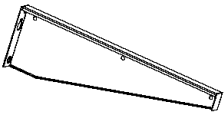
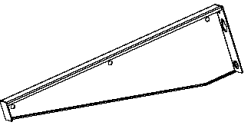
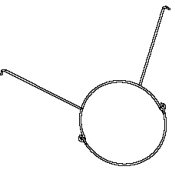
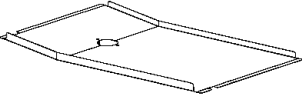
Item No.	Description	Part #	Qty	Graphic
S	Side Burner Front Bracket	SA0394	1	
T	Side Shelf Front Bracket	SA0402	1	
U	Cylinder Support Ring	SE0085	1	
V	Grease Tray	SA0320-3	1	

Parts Diagram for Models 119.162300

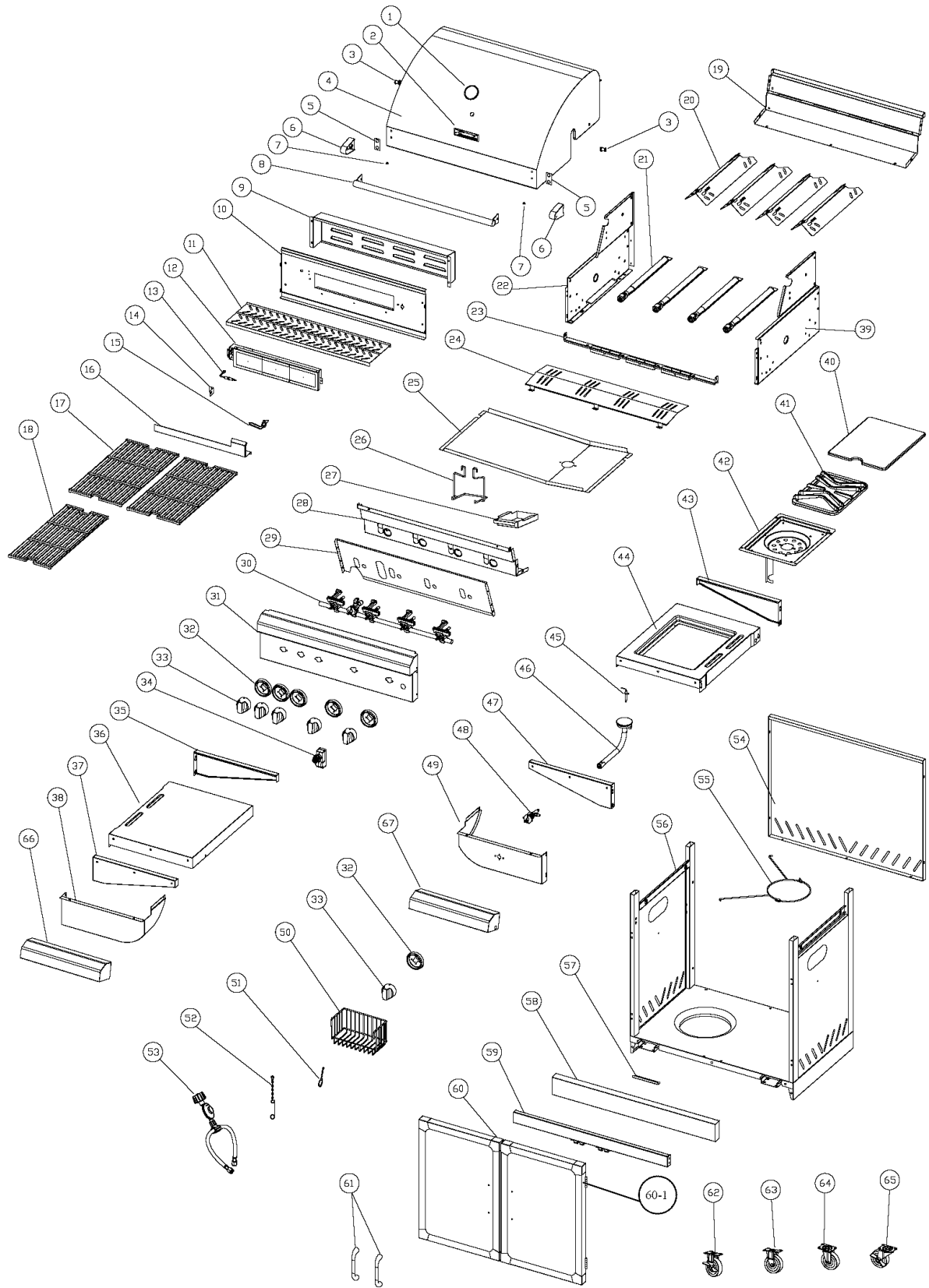

Parts List for Models 119.162300

KEY	Description	Part #	QTY
1	Thermometer	SE0076	1
2	Name Plate	ZA0015	1
3	Hood Bolt Assembly	SB0001-1/SB0002-1/SB0003-1	2
4	Hood	SA0101-A/SA0404-1/SA0405	1
5	Heat Insulator for Hood Handle	FE0010	2
6	Hood Handle Connector	ZA0010	2
7	Hood Silicon Stopper	FE0001	2
8	Hood Handle	RSA0004	1
9	Back Burner Cover	SA0413	1
10	Firebox Back Top Panel	SA0412	1
11	Warming Rack	SA0414	1
12	Back Burner	SD0006	1
13	Flame Sensor	SC0014	1
14	Flame Sensor Support	SA0030	1
15	Back Burner Electrode	SI0850	1
16	Back Burner Front Panel	SA0028	1
17	Cooking Grate - Large	CI0009	2
18	Cooking Grate - Small	CI0008	1
19	Firebox Back Panel	SA0411	1
20	Heat Diffuser	SA0415	4
21	Main Burner	SD0012-1	4
22	Firebox Left Panel	SA0451	1
23	Main Burner Bracket	SA0408	1
24	Bottom Heat Shield	SA0416	1
25	Grease Tray	SA0320-3	1
26	Grease Pan Support	SE0077	1
27	Grease Pan	SA0375	1
28	Firebox Front Panel	SA0410	1
29	Firebox Front Heat Shield	SA0409-3	1
30	Gas Manifold Assembly	SC0014	1
31	Main Burner Control Panel	SA0319	1
32	Control Knob Seat	FE0016	6
33	Control Knob	FE0015	6

Parts List for Models 119.162300

KEY	Description	Part #	QTY
34	Electric Igniter	SE0010	1
35	Side Shelf Back Support	SA0403	1
36	Side Shelf Frame	SA0426	1
37	Side Shelf Front Support	SA0402	1
38	Side Shelf Control Panel	SA0327	1
39	Firebox Right Panel	SA0451	1
40	Side Burner Cover	SA0390	1
41	Side Burner Grate	CI0011	1
42	Side Burner Inner Frame	SA0396	1
43	Side Burner Back Support	SA0395	1
44	Side Burner Shelf Frame	SA0389	1
45	Side Burner Electrode	SE0083	1
46	Side Burner	CI0010	1
47	Side Burner Front Support	SA0394	1
48	Side Burner Valve	SC0015	1
49	Side Burner Control Panel	SA0326	1
50	Condiment Basket	SE9027	1
51	Gas Hose Support Ring	SE0080	1
52	Manual Igniter Stick	SE0019	1
53	Regulator & Hose	SE0079	1
54	Cabinet Back Panel	SA0324	1
55	Cylinder Support Ring	SE0085	1
56	Cabinet	06W1C-C	1
57	Cabinet Door Stopper	SA0422	1
58	Cabinet Toe Plate	SA0321	1
59	Cabinet Front Crossbar	SA0421	1
60	Cabinet Left Door	SA0322/SA0323/SA0420-1	1
60-1	Cabinet Right Door	SA0322/SA0323/SA0420-1	1
61	Cabinet Door Handle	SE0087	2
62	Locking Caster	SE0057	1
63	Caster	SE0056	1
64	Swivel Caster	SE0081	1
65	Locking Swivel Caster	SE0055	1
66	Side Shelf Top Panel	SA0325	1
67	Side Burner Top Panel	SA0325	1

Assembly Instruction

Please refer to pages 5 through 8 for item graphics.

1

Install Casters

- Place the Cabinet Assembly (A) upside down and attach the 4 Casters to the Caster Seats. Use care to install each Caster into the correct position.

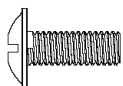
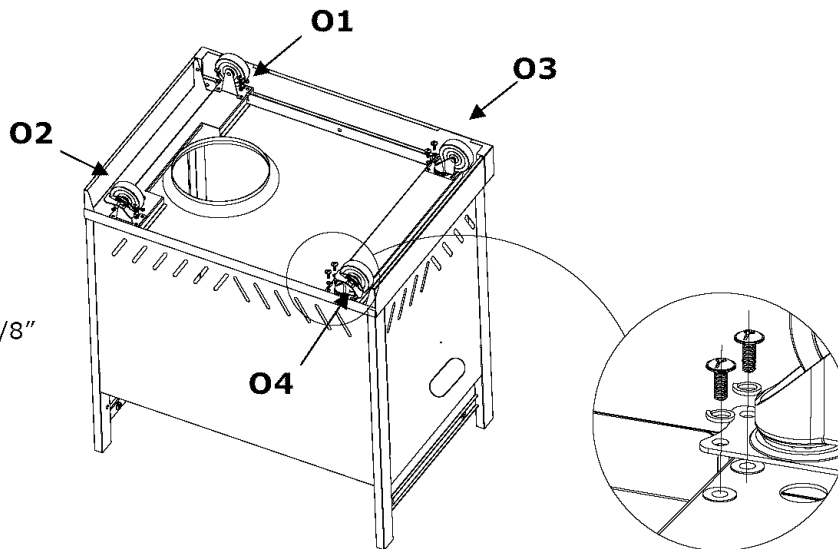

Phillips Head Bolt: M6x5/8"
(with blue paint)
Qty: 16
Part # SB0027



Washer: M6
Qty: 16
Part # SB0005

2

Install Cylinder Support Ring, Cabinet Front Crossbar and Cabinet Door

- Put the Cylinder Support Ring (U) into two holes in left side cabinet frame. See Inset 1
- Attach the Cabinet Front Crossbar (B) to the Cabinet Assembly using 4 Bolts M6x3/8" and 4 M6 Washers. See Inset 2.
- Attach Cabinet Left Door (J) and Cabinet Right Door (K) to the Cabinet Assembly using 8 Bolts M4x3/8". See Inset 3.



Phillips Head Bolt: M6x3/8"
Qty: 4
Part # SB0004



Washer: M6
Qty: 4
Part # SB0005



Flat Head Bolt: M4x3/8"
Qty: 8
Part # SB0029

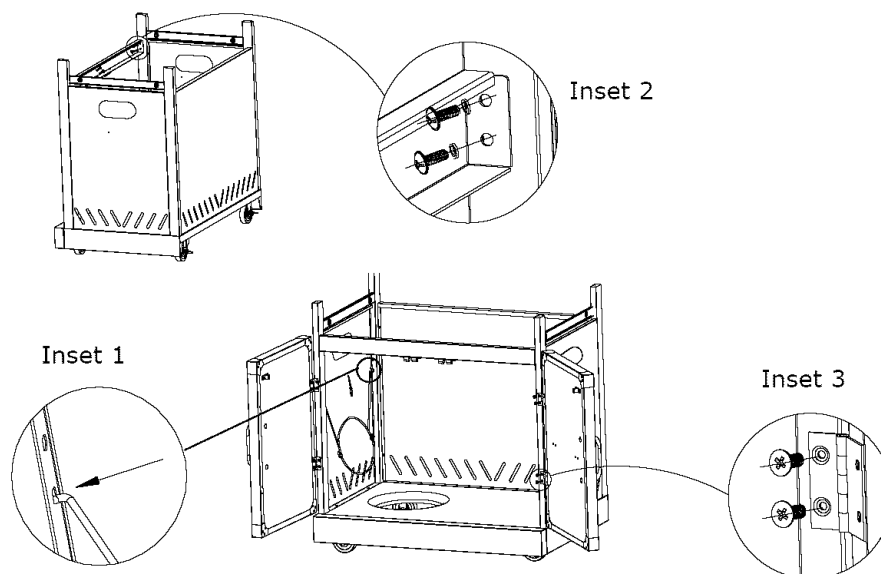

3

Install Condiment Basket and Cabinet Door Stopper

- Hang the Condiment Basket (L) inside of the Cabinet Right Door (K) as shown.
- Attach the Cabinet Door Stopper to the Cabinet Bottom Panel using 2 M4x5/16" Phillips Head Bolts and 2 M4 Washers.



Phillips Head Bolt: M4x5/16"
(Black)
Qty: 2
Part # SB0009



Washer: M4
Qty: 2
Part # SB0016



Cabinet Door Stopper
Qty: 1
Part # SA0422

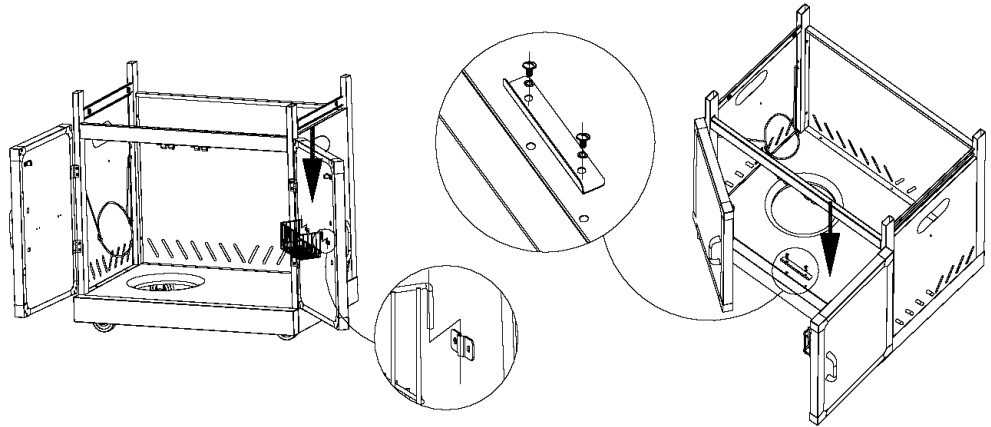

4

Install Firebox Assembly to Cabinet Assembly and Install Grease Tray to Firebox Assembly

- Place the Firebox Assembly (I) on the Cabinet Assembly (A). We recommend using 2 people to lift the Firebox Assembly (I).
- Attach the Firebox Assembly to the Cabinet Assembly using 4 M6x5/8" Phillips head Bolts and 4 M6 Washers. See Inset 1.
- Slide the Grease Tray (V) along the sides of the Firebox Assembly (I) from the back. Ensure it secures in place behind the two screws on the sides of the cabinet. See Insets 2 and 3.



Phillips Head Bolt: M6x5/8"
Qty: 4
Part # SB0027



Washer: M6
Qty: 4
Part # SB0005

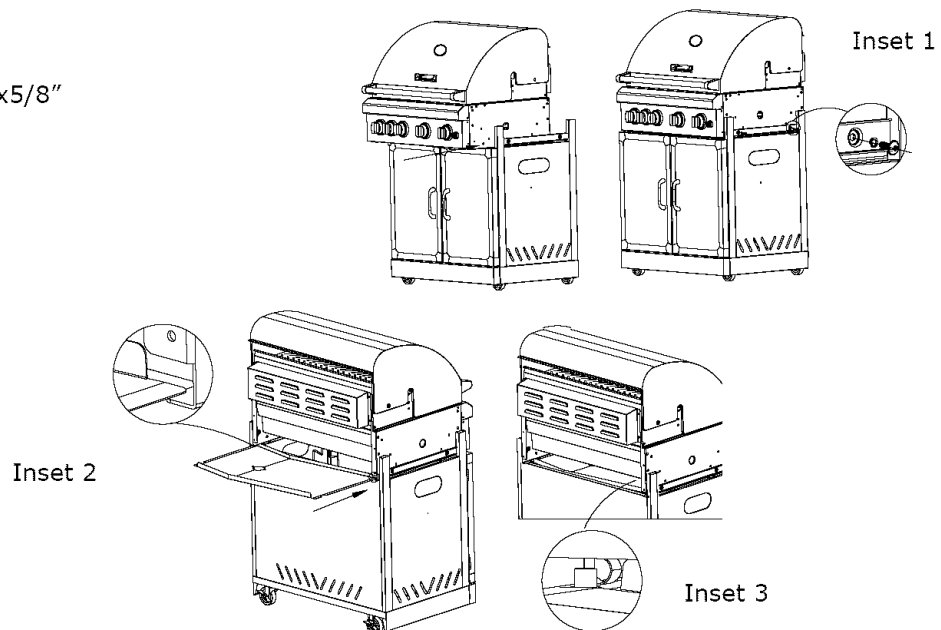

5**Install Grease Pan Support and Grease Pan**

- Attach Grease Pan Support (G) to the Grease Tray using 2 M5 Nuts. See Insets 1 and 2.
- Install the Grease Pan (H) into the Grease Pan Support (G), inserting it from the front of the cabinet. See Inset 3.

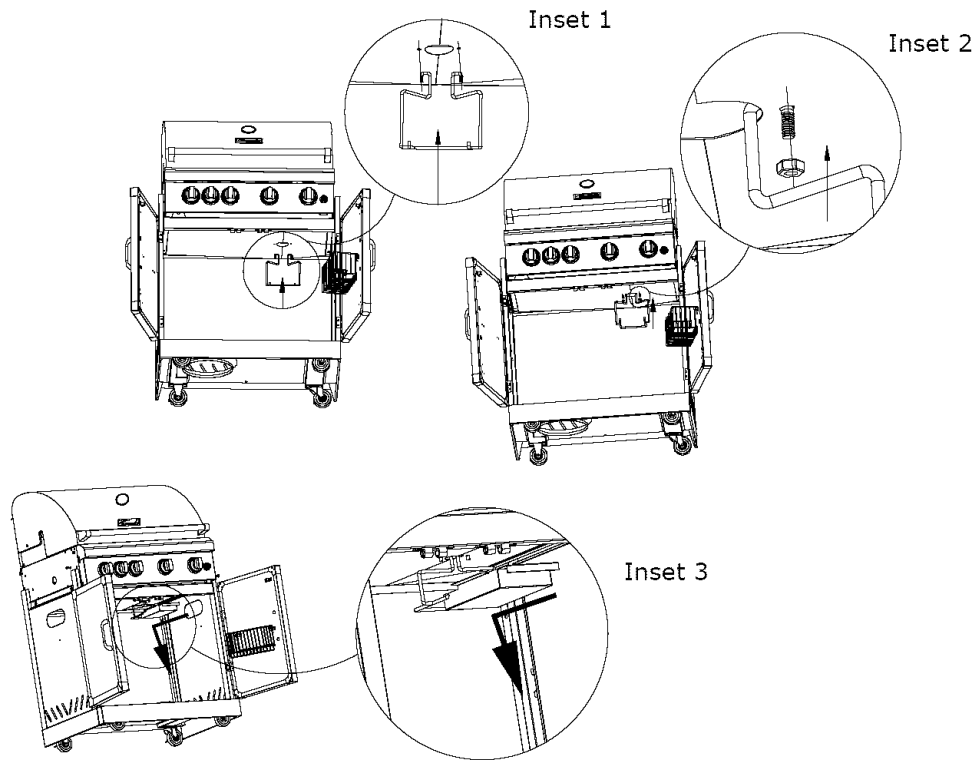

Nut: M5
Qty: 2
Part # SB0019

**6****Assemble Side Burner Assembly**

- Attach Side Burner Top Panel (Q) and Side Burner Front Bracket (S) to the Side Burner Frame (C), using 3 Phillips Head Bolts.



Phillips Head Bolt: M6x3/8"
Qty: 3
Part # SB0004

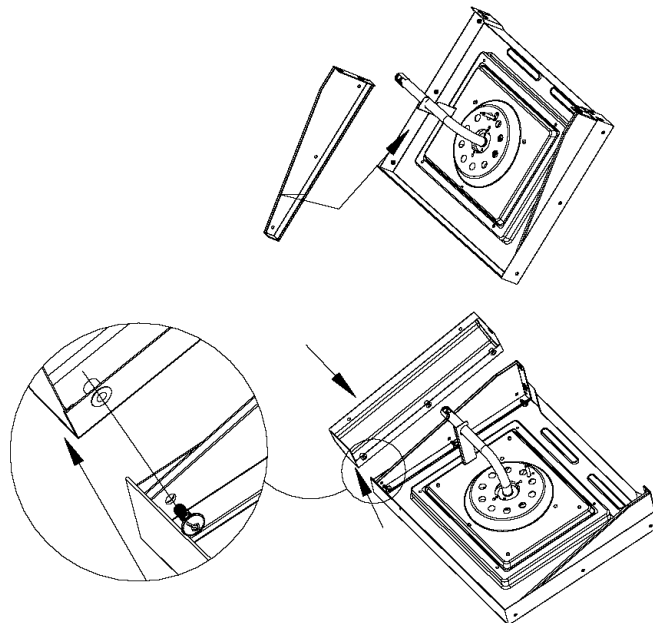

7**Install Side Burner Control Panel to Side Burner Assembly**

- ☐ Attach Side Burner Control Panel (M) to Side Burner Assembly using 3 Phillips Head Bolts and 2 Washers. Do not use a Washer on the end Bolt.



Phillips Head Bolt: M4x5/16"
(Black)
Qty: 3
Part # SB0009

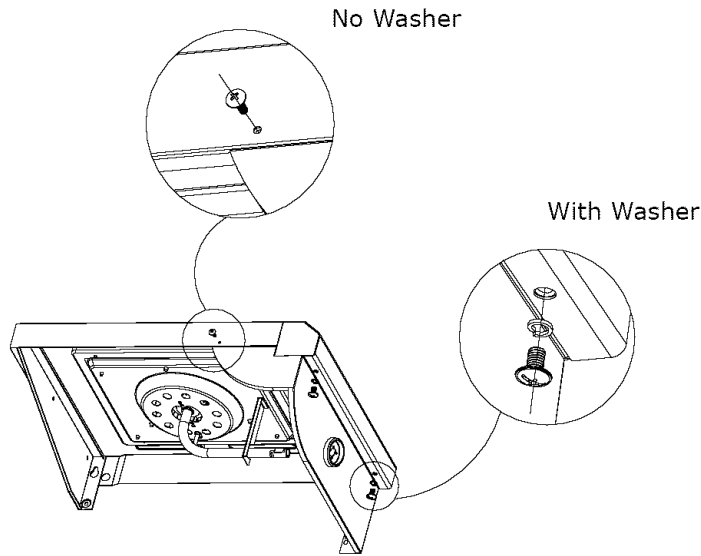

Washer: M4
Qty: 2
Part # SB0016

**8****Install Side Burner Assembly to Firebox Assembly.**

- ☐ Loosely screw 2 Phillips Head Bolts (M6x3/8") and 2 Washers into the upper left and right corner holes in the left side of the firebox as shown in Inset 1. Leave 1/4" of the bolts extending out of the firebox sides to attach the side burner brackets. Slide the Side Burner Front and Rear Brackets over the heads of those bolts and tighten.
- ☐ Slide the side burner ignition wire through the hole on the Side Burner Control Panel. See Inset 2
- ☐ Use 2 Phillips Head Bolts (M6x3/8") and 2 Washers to attach the lower holes in the Side Burner Front and Rear Bracket to the Firebox Assembly (I) as shown in Inset 3.

Inset 1



Phillips Head Bolt: M6x3/8"
Qty: 4
Part # SB0004



Washer: M6
Qty: 4
Part # SB0005

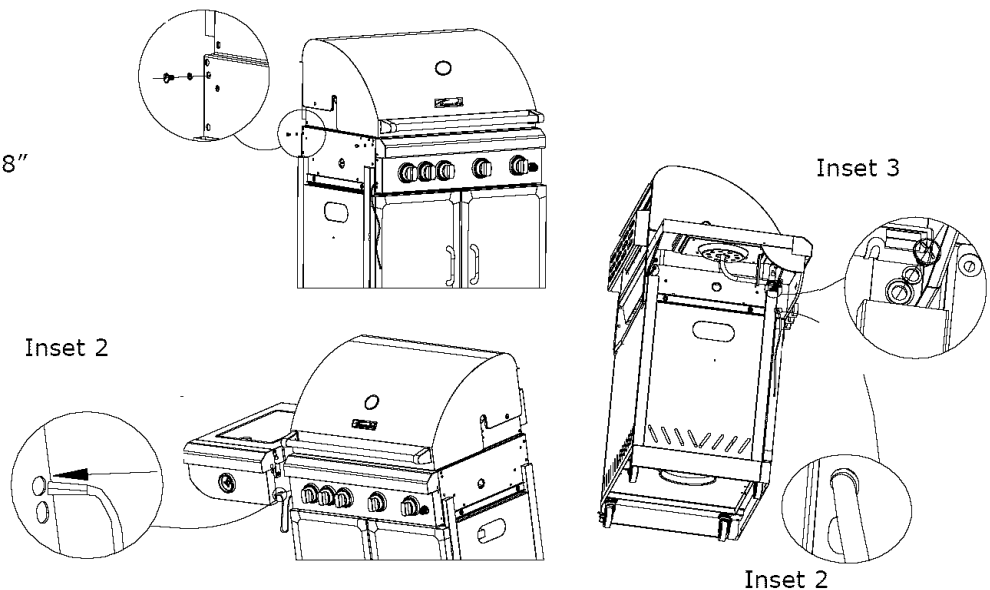

9

Secure Side Burner Assembly to the Firebox Assembly

- ☐ Use 1 Phillips Head Bolt and 1 Washer from inside of the firebox to secure attached Side Burner Assembly as shown.



Phillips Head Bolt: M6x3/8"
Qty: 1
Part # SB0004



Washer: M6
Qty: 1
Part # SB0005

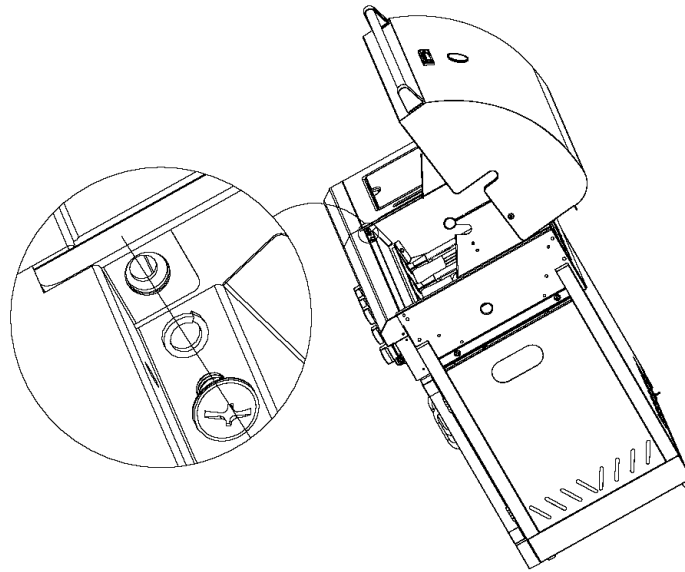

10

Secure Side Burner Valve and Control Knob to Side Burner Control Panel

- ☐ Insert the side burner valve stem up through the hole in the Side Burner Control Panel (M). See Inset 1.
- ☐ Insert side burner valve stem into the side burner tube. See Inset 2.
- ☐ Secure the side burner valve to the Side Burner Control Panel (M) using 2 white Philips Head Bolts. Ensure the side burner valve stem is centered in the stem tube of the side burner.
- ☐ If not, center it, which may involve loosening the 2 Phillips Head Bolts. See Inset 3. Push the Control Knob onto the valve stem. See Inset 3.



Phillips Head Bolt: M4x5/16"
(White)
Qty: 2
Part # SB0009D

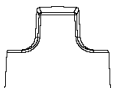

Control Knob
Qty: 1
Part # FE0015

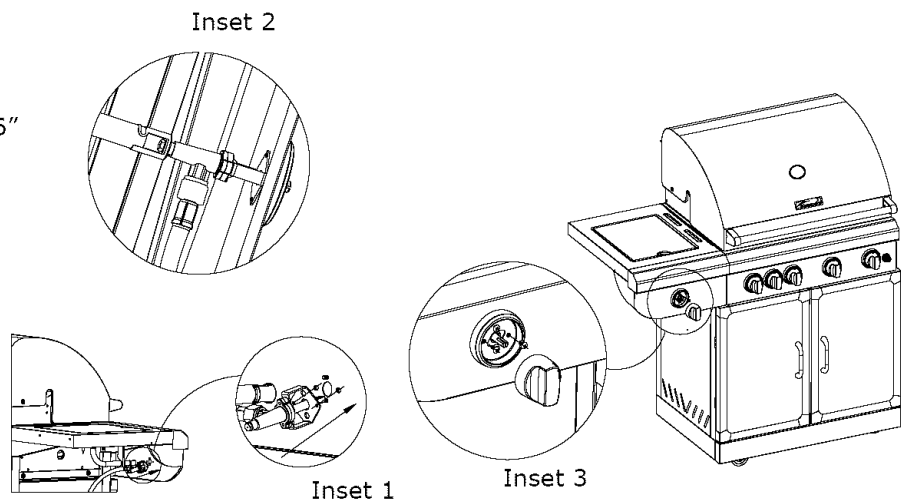

11**Attach Side Burner Control Panel to Firebox Assembly and attach Side Burner Ignition Wire**

- Use 1 Phillips Head Bolt (M4x5/16") to secure the Side Burner Control Panel (M) to the Firebox Assembly (I) as shown. See Inset 1.
- Slide the side burner ignition wire over the side burner igniter connector. See Inset 2.

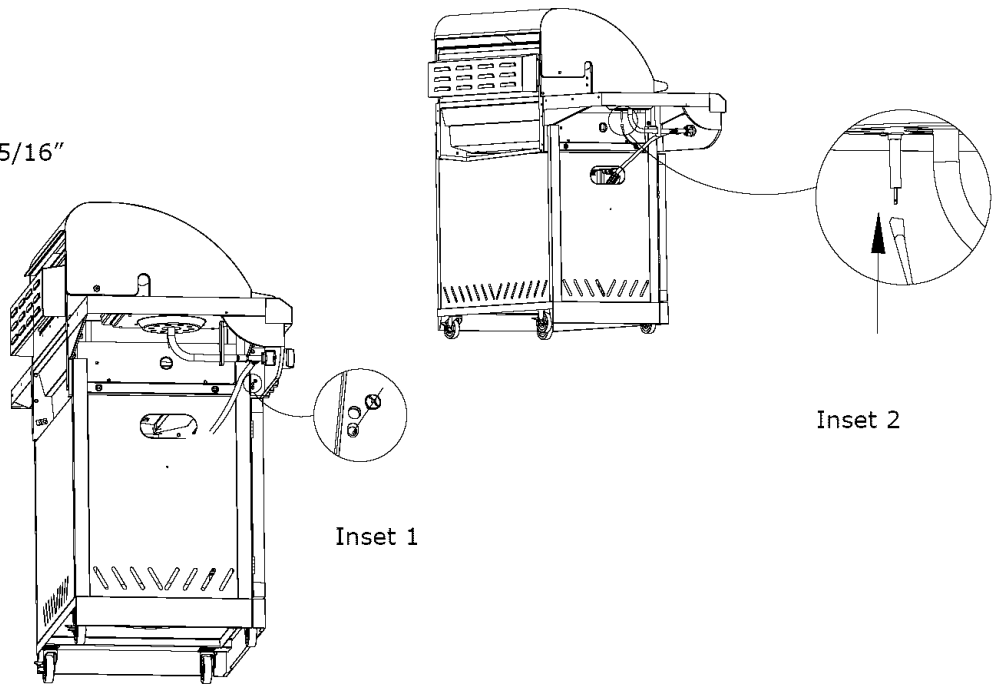

Phillips Head Bolt: M4x5/16"
 (Black)
 Qty: 1
 Part # SB0009

**12****Assemble Side Shelf Assembly**

- Attach the Side Shelf Top Panel (R) and Side Shelf Front Bracket (T) to the Side Shelf Frame (P) using 3 Phillips Head Bolts.



Philip Head Bolt: M6x 3/8"
 Qty: 3
 Part#: SB0004

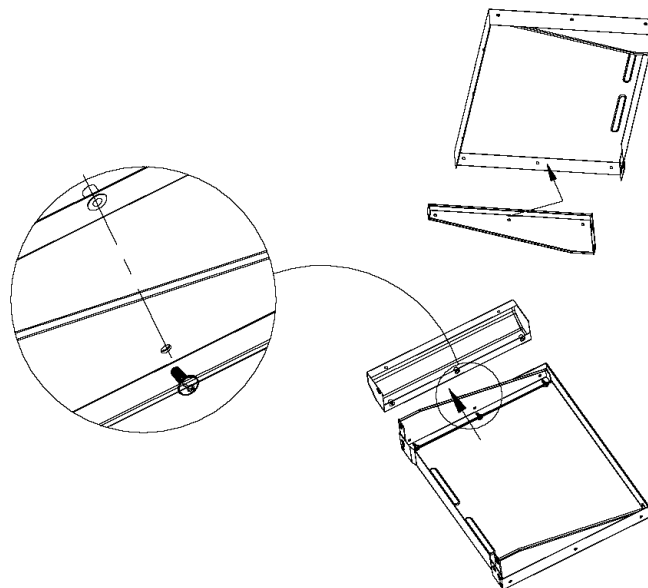

13

Install Side Shelf Control Panel to Side Shelf Assembly

- Attach Side Shelf Control Panel (N) to Side Shelf Assembly using 3 Phillips Head Bolts and 2 Washers. Do not use a Washer on the end Bolt.



Washer : M4
Qty: 2
Part # SB0016



Philip Head Bolt: M4x 5/16"
(Black)
Qty: 3
Part#: SB0009

With Washer

No Washer

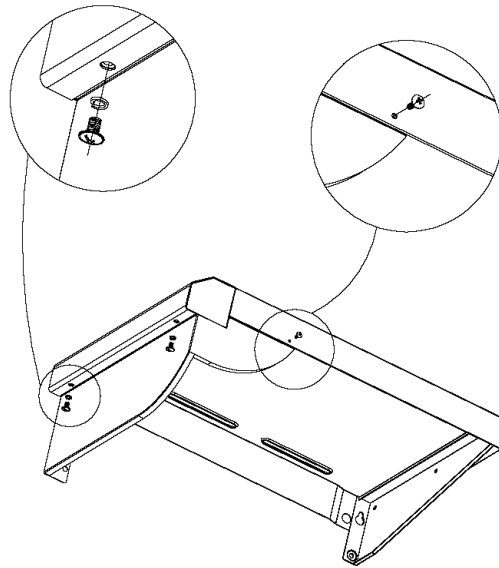

14

Install Side Shelf Assembly to Firebox Assembly.

- Loosely screw 2 Phillips Head Bolts (M6x3/8") and 2 Washers into the upper left and right corner holes in the right side of the firebox as shown in Inset 1. Leave 1/4" of the bolts extending out of the firebox sides to attach the side shelf bracket. Slide the Side Shelf Front and Rear Brackets over the heads of those bolts and tighten.
- Use 2 Phillips Head Bolts (M6x3/8") and 2 Washers to attach the lower holes in the Side Shelf Front and Rear Brackets to the Firebox Assembly (I) as shown in Inset 2.
- Use 1 Phillips Head Bolt (M4x5/16") to attach the Side Shelf Control Panel (N) to Firebox Assembly (I) as shown in Inset 3.



Phillips Head Bolt: M6x3/8"
Qty: 4
Part # SB0004



Washer: M6
Qty: 4
Part # SB0005



Phillips Head Bolt: M4x5/16"
(Black)
Qty: 1
Part # SB0009

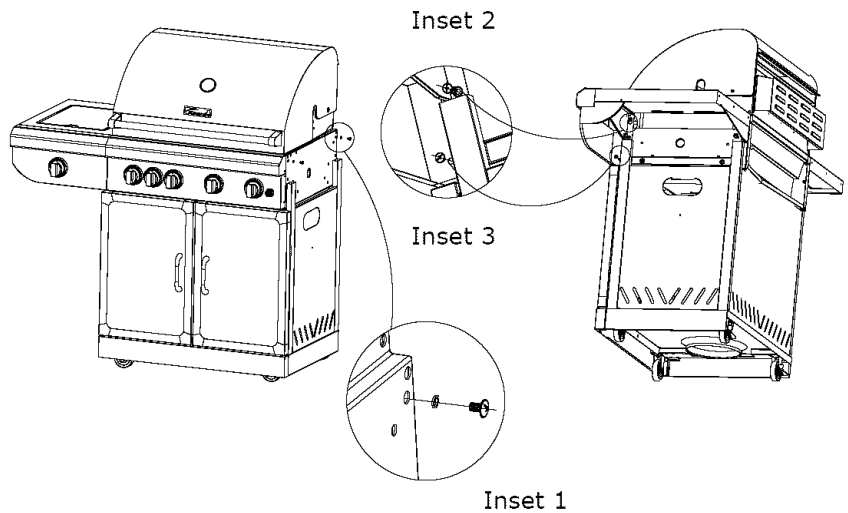

15**Secure Side Shelf Assembly to the Firebox Assembly**

- Use 1 Phillips Head Bolt and 1 Washer from inside of firebox to secure attached Side Shelf Assembly.



Phillips Head Bolt: M6x3/8"
Qty: 1
Part # SB0004

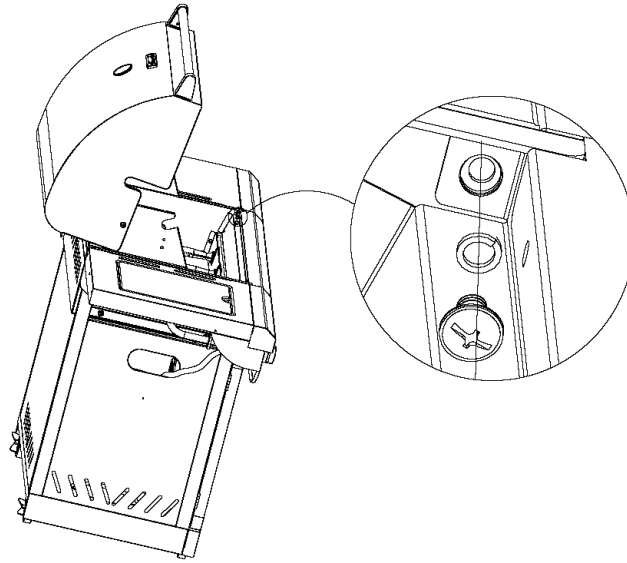

Washer: M6
Qty: 1
Part # SB0005

**16****Place Heat Diffusers, Cooking Grates, and Warming Rack into the Firebox Assembly**

- Place the Heat Diffusers (F) into the Firebox Assembly (I), Ensure the fronts of the Heat Diffusers, marked "FRONT", are at the front of the firebox.
- Place the Grates (E) into the Firebox Assembly (I). Each grate has a small knob on each corner. The knobs should rest on the front or back panels of the firebox. The 2 large and 1 small grates can be inserted in any order.
- Place the Warming Rack (D) into the slots along the top of the Firebox Assembly (I) as shown.

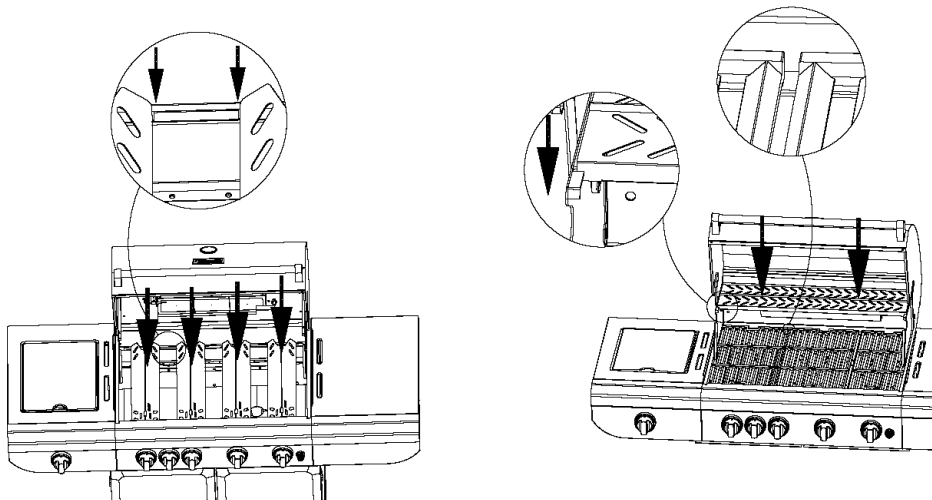

17

Place LP Cylinder into the Cabinet

- Unhook the cylinder support ring and hold at top of cabinet.
- Place the LP cylinder down into the tank support hole in the bottom of the cabinet. Ensure the valve faces to the front.
- Wrap the cylinder support ring around the top of the tank and hook to secure the LP cylinder in place.

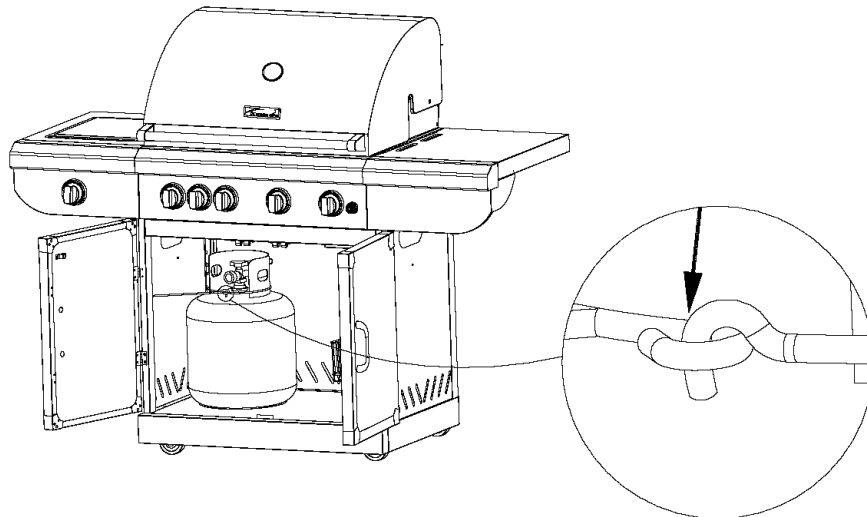

18

Attach Regulator Hose Support Ring to Cabinet Side Panel

- Remove the nut from the bolt on the inside of the left cabinet side panel, It's located towards the top of the side panel near the front. See Inset 1.
- Find the metal ring located on the hose of the regulator assembly and attach to the bolt on the left cabinet side panel securing it with the nut. This will keep the hose away from hot surfaces. See Inset 2.

DO Not Hook Up the LP Cylinder to the Regulator Assembly at this time.

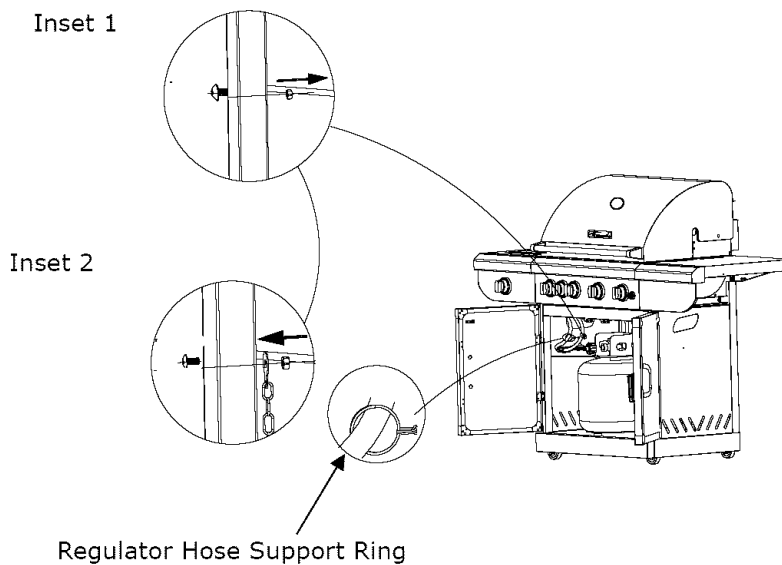

19

Install Battery

- Unscrew the electronic igniter cap. Place the "AA" Battery into the igniter with the positive (+) end up. Screw the electronic igniter cap back into place.



Battery (Size AA)
Qty: 1
Part #

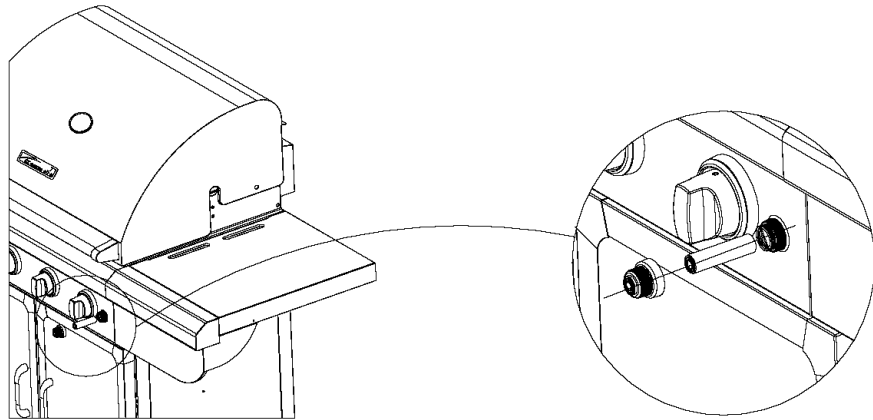

20

Congratulations – Assembly in now Complete

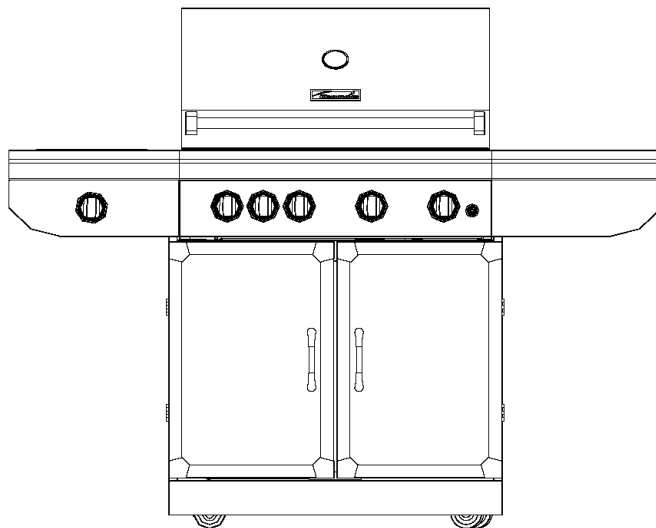

- Remove any additional labels or packing material from the grill except the CSA label. Be sure to clean all foam packing material out of all areas.
- Please proceed to and read the remaining sections of the Operator's Manual prior to hooking up your LP cylinder or operating your grill.





LP Gas Tank Installation

CORRECT LP GAS TANK USE

- LP gas grill models are designed for use with a standard 20 lb. (9.1kg) Liquid Propane Gas (LP Gas) tank, which is not included with the grill. Never connect your gas grill to an LP gas tank that exceeds this capacity. A tank of approximately 12" (305mm) in diameter by 18-1/2"(472mm) high is the maximum size LP gas tank to use. You must use an "OPD" gas tank which offers a listed Overfill Prevention Device. This safety feature prevents tanks from being overfilled which can cause malfunction of the LP gas tank, regulator and grill.
 - The LP gas tank must be constructed and marked in accordance with the Specifications for LP-Gas Cylinders of the U.S. Department of Transportation (D.O.T.) or the National Standard of Canada, CAN/CSA-B339, Cylinders, Spheres and Tubes for Transportation of Dangerous Goods; and Commission, as applicable.
 - The LP gas tank must have a shutoff valve terminating in a LP gas supply tank valve outlet that is compatible with a Type 1 tank connection device. The LP gas tank must also have a safety relief device that has a direct connection with the vapor space of the tank.
 - The tank supply system must have a means for vapor withdrawal.
 - The LP gas tank used must have a collar to protect the tank valve.
 - Never** connect an unregulated LP gas tank to your gas grill. The gas regulator assembly supplied with your gas grill is adjusted to have an outlet pressure of 11" water column (W.C.) for connection to a LP gas tank. Only use the regulator and hose assembly supplied with your gas grill.
Replacement regulators and hose assemblies must be those specified by Sears. See the Parts List.
 - Have your LP Gas dealer check the release valve after every filling to ensure it remains free of defects.
 - Always keep the LP gas tank in an upright position. Do not subject the LP gas tank to excessive heat.
 - Never** store an LP gas tank indoors. If you store your gas grill indoors, **always** disconnect the LP gas tank first and store it safely outside.
 - LP gas tanks must be stored outdoors in a well-ventilated area and out of the reach of children.
 - Disconnected LP gas tanks must not be stored in a building, garage, or any other enclosed area.
 - The regulator and hose assembly can be seen after opening the door (if applicable) and must be inspected before each use of the grill. If there is excessive abrasion or wear or if the hose is cut, it must be replaced prior to using the grill again.
 - Never** light your gas grill with the lid closed or before checking to ensure the burner tubes are fully seated over the gas valve orifices.
 - Never** allow children to operate your grill. Do not allow children or pets to play near your grill.
- Use of alcohol or drugs may impair the ability to assemble and operate the appliance.
 - Keep a fire extinguisher readily accessible. In the event of an oil or grease fire, do not attempt to extinguish with water. Use a type B extinguisher or smother with dirt, sand, or baking soda.
 - In the event of rain, cover the grill and turn off the burner and gas supply.
 - Use your grill on a level, stable surface and ensure the locking casters are locked before use.
 - Do not leave the grill unattended when in use.
 - Do not move the appliance when in use.
 - Allow the grill to cool before moving or storing.
 - Do not use your grill as a heater.
 - This grill is not intended to be installed in or on recreational vehicles and /or boats.

 **WARNING** 

A. Do not store a spare LP gas tank under or near this appliance.
B. Never fill the tank beyond 80 percent full;
C. If the information in "(a)" and "(b)" is not followed exactly, a fire causing death or serious injury may occur.

 **WARNING** 

- **Use your grill at least 2 feet away from any wall or surface** . Use your grill at least 2 feet away from combustible objects that can melt or catch fire (such as vinyl or wood siding, fences and overhangs) or sources of ignition including pilot lights on water heaters and live electrical appliances.
- **Never** use your gas grill in a garage, porch, shed, breezeway, or any other enclosed area.
- **Never** obstruct the flow of ventilation air around your gas grill housing.

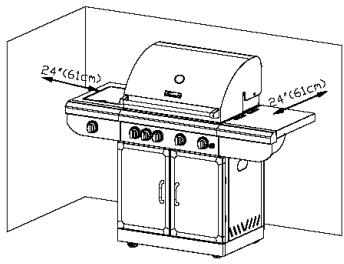

Notes about LP Gas Tank Exchange Programs



- Many retailers that sell grills offer you the option of replacing your empty LP gas tank through an exchange service. Use only those reputable exchange companies that inspect, precision fill, test and certify their tanks. Exchange your tank only for an OPD safety feature equipped tank as described in the LP gas tank section of this manual.
- Always keep new and exchanged LP gas tanks in an upright position during use, transit or storage.
- Leak test new and exchanged LP gas tanks BEFORE connecting one to your grill.

How to Leak Test your LP Gas Tank

For your safety:

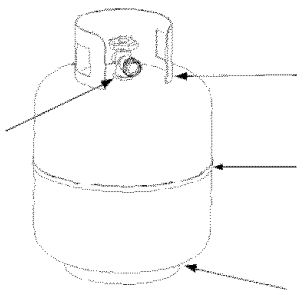

- All leak tests must be repeated each time your LP gas tank is exchanged or refilled.
 - Do not smoke when checking for gas leaks.
 - Do not use an open flame to check for gas leaks.
 - Your grill must be leak tested outdoors in a well-ventilated area, away from ignition sources such as gas fired or electrical appliances. During the leak test, keep your grill away from open flames or sparks.
 - Do not use household cleaning agents as damage to gas assembly components can occur.
- Use a clean paintbrush and a 50/50 mild soap and water solution.
- Brush soapy solution onto the LP gas tank in the areas indicated by the arrows. See diagram.
- If growing bubbles appear do not use or move the LP gas tank. Call an LP gas supplier or your fire department.



 **WARNING** 

If growing bubbles appear do not use or move the LP gas tank. Contact an LP gas supplier or your fire department!

Regulator and LP Cylinder Connections

 **WARNING** 

The gas pressure regulator provided with this outdoor cooking appliance must be used. This regulator is set for an outlet pressure of 11 inches water column.

Regulator:

Your regulator is equipped with a Q.C.C. Type 1 quick connect system. It will not allow gas to flow until a positive seal has been made. It has a thermal element that will shut off the gas flow if the temperature reaches 240 degrees F (115 degrees C). It also has a flow-limiting device that will restrict the flow of gas to 10 cubic feet per hour (0.28 cubic meters per hour).

TO CONNECT THE CYLINDER TO THE REGULATOR AND HOSE

1. Be sure the LP cylinder is "OFF" by turning the hand wheel clockwise until it stops.
2. Place the cylinder into the base cabinet shelf of the grill with the valve facing outward and secure with the cylinder support ring.
3. Be sure all burner controls are turned to the "OFF" position.
4. Remove the safety cap from the cylinder valve.
5. Center the nipple of the regulator into the cylinder valve.
6. Turn the black nut clockwise until it stops.
Hand Tighten Only. Do Not Use A Wrench.

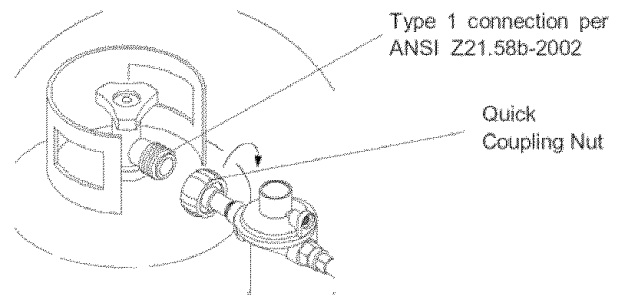

CAUTION: When the appliance is not in use the gas must be turned off at the tank.

Flow Limiting Valves on LP Gas Tanks

Your LP gas tank is equipped with a flow limiting valve that will restrict the flow of gas due to a sudden change in pressure. This can often activate without your knowledge. You will notice among other things that your grill does not get as hot as it should, will take longer to heat up, or you may not be able to light all burners. If you notice any of the above, then you should reset the valve and clear your gas line.

To do this

1. Ensure the LP gas tank valve is OFF.
2. Disconnect the regulator from the LP gas tank.
3. Open all burner control knobs including the side burner to Hi/Light at the same time.
4. Close all burner control knobs to OFF.
5. Let the LP gas tank stand for at least 10 minutes.
6. Reconnect the regulator assembly to the LP gas tank.
7. Slowly, meaning about 1/4 turn at a time, turn on the LP gas valve.
8. Follow the burner lighting procedures to light the burner farthest away from the gas source.
9. The flow limiting valve should now be reset.

This flow limiting valve is triggered by sudden changes in pressure. This can be caused by a leak, faulty connection of the regulator to the LP gas tank, turning on the LP gas tank valve too quickly, or turning the burners off by turning the LP gas tank valve off before turning the burner control knobs to off. Note: always turn off your burners using the burner control knobs first before turning the LP gas tank valve off.

Transportation and Storage

1. Place a dust cap on the cylinder valve outlet whenever the cylinder is not in use. Only install the type of dust cap on the cylinder valve outlet that is provided with the cylinder of propane valve. Other types of caps or plugs may result in leakage.
2. Always transport your cylinder in an upright position.
3. Do not smoke when transporting your cylinder.

Check all connections for LP Gas Leaks

- Never** test for leaks with a flame. Prior to first use, at the beginning of each season or every time your LP Gas tank is changed you must check for gas leaks. Follow these three steps:
- Make a soap solution by mixing one part liquid detergent and one part water
- Turn the burner control knobs to the OFF position. Then turn the gas ON at the source.
- Apply the soap solution to all gas connections indicated by the arrows. See diagram. If bubbles appear in the soap solution the connections are not properly sealed. Check each fitting and tighten or repair as necessary.

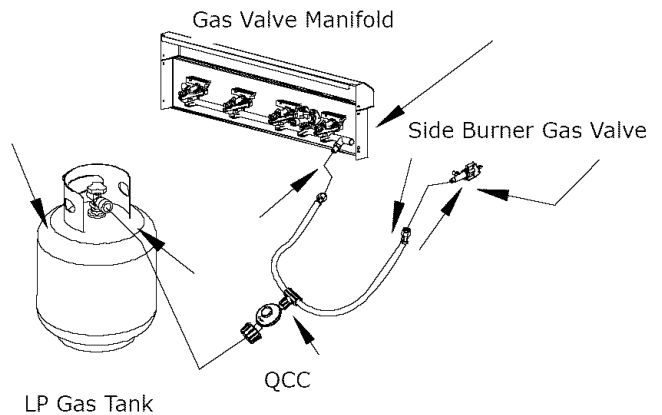

	WARNING	
<p>If you have a gas leak that cannot be repaired by tightening, turn off the gas at the source, disconnect fuel line from your grill and call 1-800-4-MY-HOME® or your gas supplier for repair assistance.</p>		

Disconnecting A Liquid Propane Gas (LPG) Tank From Your Grill

- Make sure the burner valves and LP gas tank valve are off. (Turn clockwise to close.)
- Detach the hose and regulator assembly from the LP gas tank valve by turning the quick coupling nut counterclockwise

USE AND CARE INSTRUCTIONS

Main Burner Lighting Instructions Lighting The Main Burner Burners With Push And Turn Ignition

1. Before each use, check all hoses for cracks, nicks, cuts, or abrasions. If a hose is damaged in any way, do not use your grill before replacing the hose with an authorized part from the Parts List. Also make sure all gas supply connections are securely tightened.
2. Familiarize yourself with the Safety and Use and Care instructions in this manual. Do not smoke while lighting the grill or checking gas supply connections.
3. Be sure the LP gas tank has gas.
4. Open the grill lid.
5. Check that the end of each burner tube is properly located over each valve orifice.

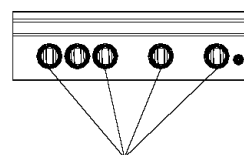

Main Burner

8. When lit, turn the burner control knob to its desired heat setting.

Side Burner and Back Burner Lighting Instructions Lighting The Side Burner Or Back Burner With Electronic Ignition

Follow steps 1 through 5 of the Main Burner Lighting Instructions.

1. Open the lid or side burner cover.
2. Set control knobs to OFF and open the LP gas tank valve SLOWLY.
3. Push and turn the side burner or back burner control knob to "HI/LIGHT".
4. Immediately press the electric igniter button for 3-5 seconds to light the burner. You should hear a clicking sound which shows the electronic ignition is working.
5. If the burner does not light within 5 seconds, turn the burner control knob to "Off". Wait 5 minutes for the gas to clear, and repeat the above procedure.
6. For the back burner, continue to push and hold the burner control knob in for 5 to 7 seconds after the burner lights until the flame sensor begins operating. Letting up on the burner control knob before a high enough temperature has been reached may cause the flame sensor to shut off fuel to the back burner.

WARNING

Failure to replace a faulty hose, secure gas supply connections, or to open the lid before proceeding to the Lighting Procedures could result in a fire or explosion that could cause serious bodily injury, death, or property damage.

6. Set control knobs to OFF and open the LP gas tank valve SLOWLY.

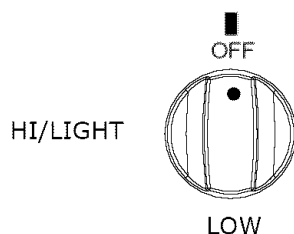

7. Push in the burner control knob of the main burner you wish to light and turn left to "HI/LIGHT". You will hear a click as a spark is sent to the burner. If the burner does not light, then turn back to "OFF", and repeat this procedure. Continue this process until the burner lights.

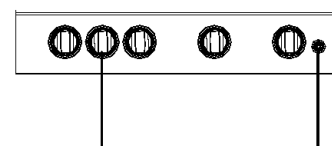
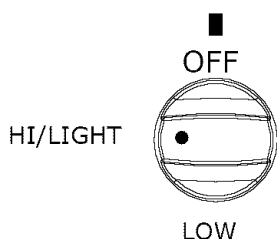

Back Burner

Electric Igniter

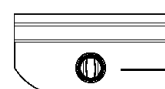

Side Burner

USE AND CARE INSTRUCTIONS

MANUALLY LIGHTING THE BURNERS WITH THE MATCH HOLDER

1. Open the lid.
2. Ensure all burners are in the "OFF" position.
3. Slowly turn on the gas at the LP cylinder valve if it is not already on.
4. Place a match in the match light stick. This is located in the inside of a cabinet door.
5. Use the stick to slide the lit match through the cooking grates and the front of the heat diffuser to the burner you wish to light.
6. Press and turn the burner control knob to "HI/LIGHT". Continue to push in and hold up to 5 seconds or until the burner lights.
7. If the burner does not light within 5 seconds, turn the burner control knob to "OFF". Wait 5 minutes for gas to clear, and try again.
8. When lit, turn the control knob to the desired heat setting

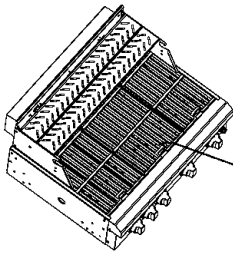

3. Slowly turn on the gas if it is not already on.
4. Place a match in the match holder if lighting the back burner. This is attached to the inside of a cabinet door.
5. Strike the match, and place near the top of the burner if lighting the side burner or near the center of the back burner if lighting the back burner.
6. Push in and turn the appropriate burner control knob to "HI/LIGHT" and hold in.
7. If the burner does not light within 5 seconds, turn the burner control knob to "OFF". Wait 5 minutes for the gas to clear, and try again.
8. For the back burner, continue to push and hold the burner control knob in for 5 to 7 seconds after the burner lights until the flame sensor begin operating. Letting up on the burner control knob before a high enough temperature has been reached may cause the flame sensor to shut off fuel to the back burner.
9. When lit, turn the burner control knob to its desired setting.

MANUALLY LIGHTING THE SIDE BURNER OR THE BACK BURNER

1. Open the lid or side burner cover
2. Ensure the side burner and back burner control knob is in the "OFF" position as well as any main burner not in use.

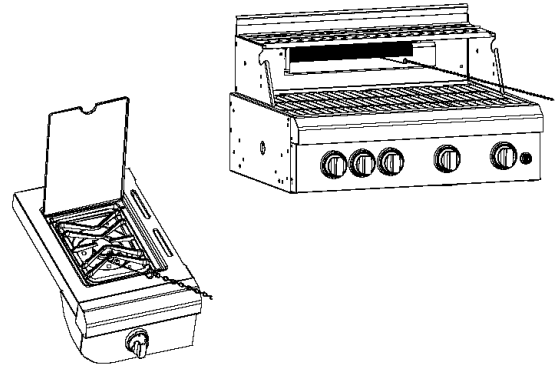

WARNING



1. Do not use charcoal briquettes, lava rock, or any type of ceramic product in this grill.
2. Do not put a barbecue cover or other flammable material in the storage area of this grill.



WARNING



Never lean over the grill cooking area while lighting your gas grill. Keep your face and body a safe distance (at least 18 inches) from the lighting hole and burners when lighting your grill with a match.

USE AND CARE INSTRUCTIONS

Troubleshooting

If the grill fails to light:

1. Turn gas off at source and turn control knobs to "OFF". Wait at least 5 minutes for gas to clear, and then retry
 2. If your grill still fails to light, check the gas supply and connections. Ensure gas supply is turned on (turn counterclockwise), there is gas in the tank, and the regulator is properly seated in the tank valve.
 3. Repeat lighting procedure. If your grill still fails to light, turn the gas off at the source, turn the control knobs to "OFF", and check the following:
- Obstruction in Gas Line
Correction: Detach regulator hose assembly. Do not smoke! Open all control knobs at the same time to "High". Close all burner control knobs to "OFF" and reattach the regulator hose assembly to the grill.
 - Plugged Orifice or Burner Tube Obstruction
Correction: Remove burners from grill and clean following the burner cleaning instructions later in this manual. Observe valve orifice to be sure there is no obstruction visible.
 - If an obstruction is suspected in Gas Valve or Manifold, call the Customer Support Center.
 - Misalignment of Igniter and Burner
Correction: Check for proper position of the electrode tip. The gap between the electrode tip and burner should be approximately 3/16 of an inch. Adjust if necessary. With the gas supply off and all control knobs set to "OFF" press the electric igniter button and check for the presence of a spark at the electrode.
 - Disconnected Electric Wires
Correction: Inspect the electric igniter (see Parts List) found behind the control panel. Connect loose electric wires to ignition assembly.
 - Weak AA Battery
Correction: Unscrew the igniter cap and replace the battery.



Do not dispose of batteries in fire! Batteries may explode or leak.

- If the grill still does not light you may need to reset the flow limiting valve in your LP tank.
Note: This procedure should be done every time a new LP gas tank is connected to your grill.

Follow the steps below to reset the flow limiting device.

- Turn LP gas tank valve "OFF".
- Disconnect the regulator assembly from LP Gas tank.
- Open all burner control knobs to "HI/LIGHT" at the same time.
- Close all burner control knobs to "OFF"
- Let the LP Gas tank stand for at least 10 minutes.
- Reconnect the regulator assembly to the LP Gas tank.
- Slowly turn on the LP Gas tank valve.
- Follow the burner lighting procedures to light the burner farthest away from the gas source.



Should a FLASHBACK fire occur in or around the burner tubes, follow the instructions below. Failure to comply with these instructions could result in a fire or explosion that could cause serious bodily injury, death, or property damage.

- Shut off gas supply (turn the LP tank valve clockwise) to the gas grill.
- Turn the control knobs to the "OFF" position.
- Open the grill lid.
- Put out any flame with a Class B Fire extinguisher
- Once the grill has cooled down, clean the burner tubes and burners according to the cleaning instructions in this Operator's Manual.

Customer Support Center

Call 8:30 AM to 5:00 PM CST **1-800-933-0527** Monday through Friday.

CLEANING AND MAINTENANCE

Proper care and maintenance will keep your grill in good operating condition and prolong its life. Follow these cleaning procedures on a timely basis and your grill will stay clean and operate with minimum effort.

CAUTION: Be sure your grill is off and cool before cleaning, and always wear protective gloves when cleaning your grill

Cleaning The Cooking Grates

Wash your cooking grates in a mild soap and warm water solution. You can use a wash cloth, vegetable brush, or brass bristled brush. Never use any type of steel bristled brush. Dry them when finished.

Cleaning the Heat Diffusers

Wash the heat diffusers periodically in a soap and warm water solution. Use a vegetable brush to remove stubborn burnt-on cooking residue. Dry the heat diffusers thoroughly before you reinstall them into the firebox.

Cleaning the Grease Tray and Pan

To reduce the chance of fire, the grease tray and grease pan should be visually inspected before each grill use. Remove any grease and wash both with a mild soap and warm water solution.

Cleaning the Inside of the Grill Lid

Grease can have a tendency to build up on the inside of the grill lid and could drip onto the deck or patio when the lid is opened. Visually inspect the inside of the grill lid before each grill use. Remove any grease and wash with a mild soap and warm water solution.

Annual Cleaning of the Grill Interior

Burning-off excess food after every cookout will keep it ready for instant use. We recommend you periodically give the entire grill a thorough cleaning to minimize your risk of grease fire and keep the grill in good shape. Follow these steps:

1. Turn all burner valves to the "OFF" position.
2. Turn the LP gas tank valve to the "OFF" position.
3. Disconnect the regulator assembly from the gas tank. Inspect the hose for cracking, cuts or any other damage, and replace as necessary. Refer to the Parts List in this Operator's Manual.
4. Remove and clean the cooking grates, heat diffusers, warming rack, burners, and grease tray.
5. Cover each gas valve orifice with aluminum foil.
6. Brush the inside and bottom of the grill with a fiber pad or nylon brush and wash with a mild soap and warm water solution. Rinse thoroughly and let dry.
7. Remove aluminum foil from orifices and check each orifice for obstruction.
8. Replace the burners, ensuring the burners fit down over each valve orifice.

9. Check and clean each electrode tip. Adjust the spacing between the tips and the burner as necessary. The space between the electrode tip and burner should be approximately 3/16".
10. Replace the heat diffusers, grates, warming rack, and grease tray.
11. Reconnect the gas source and observe the burner flame for correct operation.

Cleaning Exterior Surfaces:

Cleaning Exterior Surfaces:



Wash with a mild dish soap and warm water solution. A cloth, soft brush, or plastic cleaning pad can be used. Rinse thoroughly and wipe dry.

Cleaning Exterior Stainless Steel Surfaces:

Wash with a mild dish soap and warm water solution. Clean and polish with a stainless steel cleaner. There are many good quality stainless steel cleaners and polishes available. Follow the manufacturer's directions. Always polish in the direction of the lines. Do not allow dirt and grease to accumulate. Do not use steel wool as it will scratch the surface. Do not use abrasive cleaners and scrubbers.

CAUTION:

Heat, weathering, machine oils used in the manufacturing of stainless steel, and dirt can all cause exterior stainless steel surfaces to turn tan in color. In addition, the following products and naturally occurring substances in the outdoors will damage all stainless steel finishes. Use caution so they will not come in contact with your grill. Immediately wash them off and dry the stainless steel should they ever come in contact with your gas grill. They include, but are not limited to, pool chemicals (chlorine and bromine), lawn fertilizer, ice melting salts, sea or salt water, urine, bird droppings, and tree sap.

	WARNING	
<p>Failure to comply with these instructions may result in a hazardous situation which, if not avoided, may result in injury.</p> <p>Keep grill area clear and free from combustible materials, gasoline and other flammable vapors and liquids.</p> <p>Do not obstruct the flow of air for combustion and ventilation.</p> <p>Keep the ventilation openings of the tank enclosure cabinet free and clear of debris.</p>		

CLEANING THE BURNER TUBES AND BURNER PORTS

To reduce the chance of **FLASHBACK FIRE** you must clean the burner tubes as follows periodically in summer and fall, wherever spiders are active in your area, and if your grill has not been used for an extended period of time.

1. Turn all burner control knobs to the "OFF" position.
2. Turn the LP gas tank valve to the "OFF" position.
3. Disconnect the LP gas regulator assembly from the LP gas tank.
4. Remove the cooking grates, heat tents, grease cup, and grease tray from the grill.
5. Remove the screw from the rear of each burner using a Phillips head screwdriver.
6. Carefully lift each burner up and away from the gas valve orifice.
7. Check and clean burner tubes for insects and insect nests. A clogged tube can lead to a fire beneath the grill.
8. Refer to FIGURE 1 and use one of these three cleaning methods:

METHOD 1: Bend a stiff wire or wire coat hanger into a small hook as shown and run the hook through the burner tube and inside the burner several times to remove debris.



METHOD 2: Use a bottle brush with a flexible handle and run the brush through the burner tube and inside the burner several times to remove any debris.

METHOD 3: Use an air hose to force air through each burner tube. The forced air should pass debris or obstructions through the burner and out the ports. Always wear eye protection if using this method.

Figure 1
TO CLEAN BURNER TUBE,
INSERT HOOK AS INDICATED BY THE ARROW

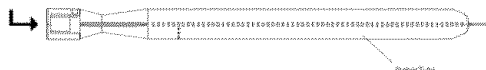

WARNING

Small insects, such as spiders, are able to access the burner tubes. Sometimes they will build nests or spin webs. In either case, this can block or reduce the amount of gas flowing through the burner. You will usually see a smaller flame, or a flame that is mostly yellow rather than blue, coming from the burner when this happens. Other signs include the grill not heating evenly, not reaching temperature, or burners not igniting. In cases with severe blockage, this can cause the flame to burn backwards, and outside of the burner tubes, which can cause damage to your grill and/or personal injury. **IMMEDIATELY SHUT OFF THE FLOW OF GAS AT THE LP TANK OR NATURAL GAS VALVE SHOULD THIS HAPPEN.** Wait for the grill to cool, and then clean all burners.

29

Regardless of the burner cleaning procedure you use, we recommend you also complete the following steps to help prolong burner life.

1. Use a fiber pad or nylon brush to clean the entire outer surface of each burner until free of food residue and dirt.
2. Clean any clogged ports with a stiff wire, such as an open paper clip.
3. Inspect each burner for damage (cracks or holes) and if such damage is found, order and install a new burner. After installation, check to ensure that the gas valve orifices are correctly placed inside the ends of the burner tubes. Also check the position of your electrodes.
4. Never enlarge the burner ports during cleaning.

WARNING

For safe operation ensure the gas valve assembly orifice is inside the burner tube before using your grill. See figure. If the orifice is not inside the burner tube, lighting the burner may cause explosion and /or fire resulting in serious bodily injury and /or property damage.

Gas Valve Assembly Orifice Burner Tube

BURNER FLAMES

Always inspect the burner flame after lighting. A good flame should be primarily blue with a yellow tip and have a minimum amount of noise. Some yellow tips are OK if under one inch. New burners sometimes have oil residue, which will cause yellow flame when burning off. Variations in gas supply, altitude, weather, and other factors can all impact burner performance. Older grills can also show more yellow flame as food deposits, oils, and fats can build up.

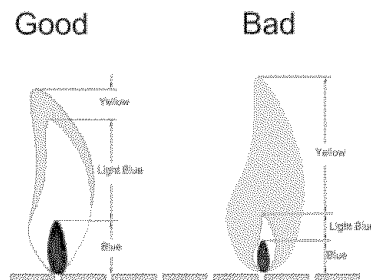

Cooking Instructions

Burn-Off

- Some of the new parts of your grill could have residual oils. We recommend you ignite the burners, turn to "HI", and lower the lid for 3 to 5 minutes to burn any oils off before grilling for the first time.

CAUTION: Operating your grill on the "HI" setting for longer than five minutes may damage certain parts of your grill.

Preheating

- To preheat, light your grill on "HI/LIGHT", lower the lid, and follow this timetable: for high temperature cooking, preheat grill 3 to 5 minutes; for low temperature cooking, preheat grill 3 minutes. Preheating is not necessary to slow cook.

Cooking Temperature

- **High Setting:** The "HI" control knob setting should only be used to sear some meats, pre-heat your grill the first 3-5 minutes and for burning food residue off the grill for 3-5 minutes after cooking is complete. Never use the "HI" setting for extended cooking.

Medium to Low Settings: Most recipes specify medium to low settings, including all smoking and rotisserie cooking, lean cuts of meat, chicken, and fish.

An Important Note About Cooking Temperature

- The outside grilling area is not the controlled environment that your indoor kitchen is. Many variables can impact the cooking performance of your grill, including outside air temperature, wind, humidity, and altitude. Allow more cooking time for cold, wind, and higher altitudes. We recommend you place the grill in an area protected from wind. Monitor your grill closely and rotate foods as needed to prevent overcooking and ensure the most delicious results every time. Experimenting makes grilling more fun and interesting!

The middle and back primary cooking areas offer the highest heat for searing and grilling.

The warming rack offers medium heat for preparing breads and firm vegetables like potatoes and corn and keeping food warm.

The front primary cooking area offers less heat and is ideal for preparing delicate foods and also for keeping cooked foods warm.

Direct Cooking

- The direct cooking method is used when food is placed directly over the lit grill burners. This method is ideal for searing, grilling, deep frying and whenever you want foods to have an open-flame barbecued taste. The lid can be open or closed depending on your preference.

Indirect Cooking

- The indirect cooking method is used for most foods. Do not place the food directly over a burner to use this method. Instead, the food should be placed on the left or right side of your grill with the burner lit on the opposite side or in the center with the center burners off. Indirect cooking must be done with the lid down.

Prepare Cooking Grates for Grilling



- Greasing the cooking surface will help keep foods from sticking and reduce the amount of cleanup required. Use a brush to apply a thin layer of cooking oil or vegetable shortening onto each cooking grate. We do not suggest spray type oils unless they are specified for high-temperature cooking. Be sure to coat the entire cooking surface including edges and any areas with chipped porcelain.

Flare-Ups

- The fats and juices dripping from grilled food can cause flare-ups. Flare-ups work to color and flavor your foods, so some flare-ups are preferred. Too many can work against you though. Reduce flare-ups by trimming away excess fat, using the indirect method of grilling, and grilling using lower temperatures.

Using the Back Burner

- The back burner is used when cooking with a rotisserie, which is sold separately. Please follow the points below when using the back burner.
 1. Always remove the warming rack.
 2. Do not use the main burners when the back burner is in use.
 3. Use an aluminum foil pan to catch the juices that drip down from the food. Allowing grease to gather in the bottom of the firebox could create a grease fire the next time the main burners are used.

WARNING

Never line the bottom of the firebox with aluminum foil, sand or any substance that will restrict the flow of grease into the grease tray or cup.

Before each use, pull out the grease tray and remove all grease and food debris to prevent a grease fire hazard.

Your grill will get very hot. Always wear a flame retardant BBQ Mitt when cooking on your grill. Never lean over cooking areas while using grill. Do not touch cooking surfaces, lid, grill housing or other parts while grill is in operation, or until the grill has cooled down after use.

FREQUENTLY ASKED QUESTIONS

Question:

Can I convert my gas grill from one fuel type to another, such as LP to NG (natural gas) or vice versa?

Answer:

No, your gas grill is manufactured to specific standards developed by CSA and ANSI for your safety and is certified for LPG (Liquid Propane Gas) use only.

Question:

Are the serial and model numbers of my grill listed somewhere for reference?

Answer:

The serial and model numbers are listed on a silver CSA label placed on the grill. Depending on the grill model, the silver CSA label generally will be located on the back panel of the cart.

Question:

My grill will not light properly. Why?

Answer:

Check these possibilities:

1. The gas supply is turned off at the LP tank. Turn on the gas at the LP tank.
2. Your LP tank is out of propane.
3. The regulator is not properly seated in the tank valve. Remove and reattach. Hand tighten only.
4. Crimped fuel supply hose. Inspect and straighten.
5. Regulator failure or damaged hose assembly. Inspect and order a replacement part. Do not use your grill if you find a damaged hose assembly.
6. Gas not getting to the burners. Inspect the burners under the control panel to be sure they are aligned with the valve orifices.
7. Blockage in the gas system. Inspect burners and valve orifices for blockages, such as spider webs, insects, etc. Clean as necessary.

Questions:

My electronic ignition is not working.

Answer:

Listen to hear the electronic igniter clicking. If not, check these possibilities:

1. Replace the AA battery. Ensure the "+" end is facing up and out.
2. Ensure the battery is centered and fits into the electronic igniter button properly.
3. Be sure the wires are all attached to the electronic ignition assembly behind the control panel and the individual electrodes.
4. Inspect the electrodes to be sure they are not coated with grease or dirt. If so, clean with rubbing alcohol.

If you hear a clicking sound, then:

1. Inspect the electrodes to be sure they are not coated with grease and dirt. Clean with rubbing alcohol.
2. Inspect the distance from the electrode to the burner. It should be 1/8 to 1/4 inch from the main burner and 1/8 to 3/16 inch from the side burner.

Question:

Sometimes I hear a humming sound coming from my regulator. What causes this?

Answer:

The humming sound is gas flowing through the regulator. This is more likely to occur in periods of high gas flow. A low volume of sound is normal and will not interfere with the operation of your grill.

Question:

My grill has a low flame on some burners, or some burners will not light at all. What can cause this?

Answer:

This can be caused by the flow limiting device, which is generally triggered by a sudden change in pressure. Opening the tank valve too fast or shutting the burners off using the tank valve can cause this. To reset:

1. Close the LP tank valve and disconnect the regulator assembly from the tank.
2. Let the LP tank sit for 10 minutes.
3. Open all burner control knobs, including the side burner, to "HI" at the same time.
4. Close all burner control knobs.
5. Reconnect the gas regulator to the LP tank.
6. Follow the burner lighting procedures and light the burner farthest from the LP tank.

Question:

Where do I use my grill for safer operation and better performance?

Answer:

Strong winds and low temperatures can affect the heating and performance of your gas grill so factor in these elements when positioning your grill outdoors for cooking.

Use your grill at least 2 feet away from any wall or surface.

FREQUENTLY ASKED QUESTIONS

Use your grill at least 2 feet away from combustible objects that can melt or catch fire (such as vinyl or wood siding, fence and overhangs) or sources of ignition including pilot lights on water heaters and live electrical appliances.

Never use your gas grill in a garage, porch, shed, breezeway or any other enclosed area.

Never obstruct the flow of ventilation air around your gas grill housing.

Question:

The Regulator and Hose supplied with my gas grill does not fit the older LP Gas Tank I've used for years. Why not?

Answer:

The U.S. Government regulates gas appliances and LP gas tanks. When regulations are changed the LP gas tank fittings are altered to insure compliance. If your LP gas tank does not fit the regulator and hose assembly supplied with your new grill, then the tank is outdated and must be replaced. Note: Effective April 1, 2002 all LP gas tanks sold must include an "OPD" Overfill Prevention Device. The OPD tanks are identified by their triangular-shaped valve wheel. This internal device prevents the LP gas tank from being overfilled. Tanks without an OPD valve can no longer be refilled.

Question:

Is it safe to clean my porcelain coated cooking grates in the dishwasher?

Answer:

No. You should not clean any grill parts in your dishwasher. We recommend you clean all parts of your grill, including the cooking grates, by hand.

Question:

Can I clean parts of my grill, such as the cooking grates and heat tents, in a self-cleaning oven?

Answer:

No. You should not clean any part of your grill in a self-cleaning oven.

Question:

What can I do to keep my cast iron grates from rusting?

Answer:

Cast iron grates do require special care. We recommend you first season new grates. Wash new grates with dishwashing liquid, rinse, and dry completely with a soft cloth. Never wash them in a dishwasher. We recommend you use a solid vegetable shortening over the grates to season them the first time. Spread a thin coating

with a paper towel over the entire surface, corners, and edges. Preheat your grill to 500 degrees. Turn half your burners to "LOW" and half "OFF", and place grates in the firebox for about an hour. Shut off all burners and allow the grates to cool. We recommend you coat the grates with a liquid vegetable oil before each use. We do not suggest spray type oils unless they are specified for high temperature cooking.

Repair Protection Agreements

Congratulations on making a smart purchase. Your new Kenmore® product is designed and manufactured for years of dependable operation. But like all products, it may require repair from time to time. That's when having a Repair Protection Agreement can save you money and aggravation.

Purchase a Repair Protection Agreement now and protect yourself from unexpected hassle and expense.

Here's what's included in the Agreement:

- Expert service** by our 12,000 professional repair specialists
- Unlimited service and no charge** for parts and labor on all covered repairs
- Product replacement** if your covered product can't be fixed
- Discount of 10%** from regular price of service and service-related parts not covered by the agreement; also, 10% off regular price of preventive maintenance check
- Fast help by phone** – phone support from Sears technician on products requiring in-home repair, plus convenient repair scheduling

Once you purchase the Agreement, a simple phone call is all that it takes for you to schedule service. You can call anytime day or night, or schedule a service appointment online.

Sears has over 12,000 professional repair specialists, who have access to over 4.5 million quality parts and accessories. That's the kind of professionalism you can count on to help prolong the life of your new purchase for years to come. Purchase your Repair Protection Agreement today!

Some limitations and exclusions apply. For prices and additional information call 1-800-827-6655.

For Sears professional installation of home appliances, garage door openers, water heaters, and other major home items, in the U.S.A. call

1-800-4-MY-HOME®

Get it fixed, at your home or ours!

Your Home

For repair – **in your home** – of **all** major brand appliances, lawn and garden equipment, or heating and cooling systems, **no matter who made it, no matter who sold it!**

For the replacement parts, accessories and owner's manuals that you need to do-it-yourself.

For Sears professional installation of home appliances and items like garage door openers and water heaters.

1-800-4-MY-HOME® (1-800-469-4663)

Call anytime, day or night (U.S.A. and Canada)

www.sears.com www.sears.ca

Our Home

For repair of carry-in items like vacuums, lawn equipment, and electronics, call or go on-line for the location of your nearest

Sears Parts & Repair Service Center

1-800-488-1222

Call anytime, day or night (U.S.A. only)

www.sears.com

To purchase a protection agreement (U.S.A.) or maintenance agreement (Canada) on a product serviced by Sears:

1-800-827-6655 (U.S.A.)

1-800-361-6665 (Canada)

Para pedir servicio de reparación a domicilio, y para ordenar piezas:

1-888-SU-HOGAR®

(1-888-784-6427)

Au Canada pour service en français:

1-800-LE-FOYER^{MC}

(1-800-533-6937)

www.sears.ca



® Registered Trademark / TM Trademark / SM Service Mark of Sears Brands, LLC
® Marca Registrada / TM Marca de Fábrica / SM Marca de Servicio de Sears Brands, LLC
^{MC} Marque de commerce / ^{MD} Marque déposée de Sears Brands, LLC

© Sears Brands, LLC