

# OPERATOR'S MANUAL

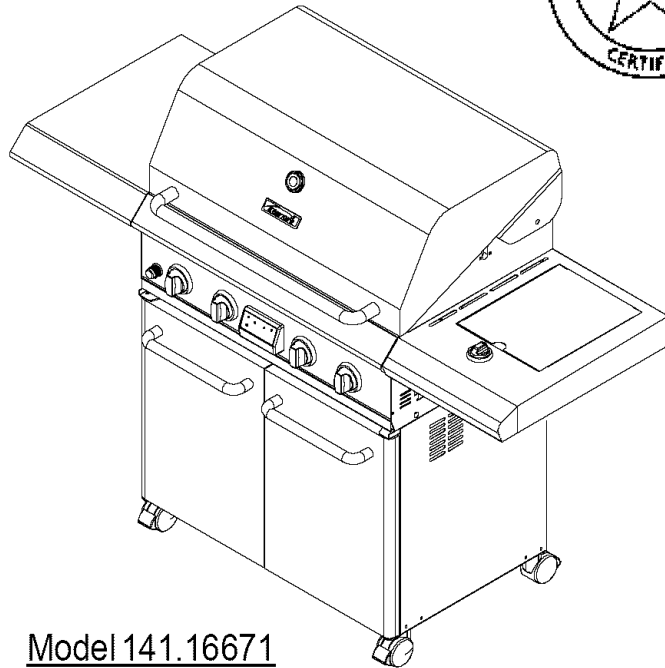

Liquid Propane Gas (LPG) Grill  
with Infrared Burners



Model 141.16671

- Safety
- Assembly
- Use and Care
- Cooking Guide
- Frequently Asked Questions

## Grill Information Center:

**Call us first** if you have any problem with this product. We can help you with questions about assembly and grill operation or if there are damaged or missing parts when you unpack this unit from the shipping box. Please call before contacting your local retailer.

**1-888-317-7642**  
8am-8pm CST, Monday through Friday

## IMPORTANT:

- **NOTE TO ASSEMBLER/INSTALLER:**  
Leave this manual with the consumer.
- **NOTE TO CONSUMER:**  
Keep this manual for future reference.
- **RECORD YOUR SERIAL #** \_\_\_\_\_  
(see silver CSA label on main body of grill)



## WARNING



- Failure to comply with these instructions could result in a fire or explosion that could cause serious bodily injury, death or property damage.
- Whether this grill was assembled by you or someone else, you must read this entire manual before using your grill to ensure the grill is properly assembled, installed and maintained.
- **Use your grill at least 5 feet away from any wall or surface.** Use your grill at least **5 feet away** from combustible objects that can melt or catch fire (such as vinyl or wood siding, fences and overhangs) or sources of ignition including pilot lights on water heaters and live electrical appliances.
- **THIS GAS APPLIANCE IS DESIGNED FOR OUTDOOR USE ONLY.**
- Combustion byproducts produced when using this product contain chemicals known to the State of California to cause cancer, birth defects, or other reproductive harm.
- This product contains chemicals known to the State of California to cause cancer, birth defects, or other reproductive harm.

Manual # P80102004L - Date:2007/03/12

## Table of Contents

Primary Safety Warnings .....	1-3
Warranty Terms and Conditions .....	2
Pre-Assembly Instructions .....	3
Part Diagrams and Lists .....	4-8
Assembly Instructions .....	9-14
LP Gas Tank Installation .....	15-16
Use & Care Instructions:	
• Lighting Instructions .....	18
• Troubleshooting .....	19
• Cleaning and Maintenance .....	20
• Cooking Guide .....	A1-A6
• Frequently Asked Questions .....	A7-A8

## Warranty

### One Year Full Warranty on Kenmore Grill

If this grill fails due to a defect in material or workmanship within one year from the date of purchase, call 1-800-4-MY-HOME<sup>®</sup> to arrange for free repair (or replacement if repair proves impossible).

### Additional Limited Warranty on Selected Grill Parts

From the date of purchase for the time periods listed below, the following specific grill parts will be supplied free of charge if they fail to meet the conditions described. After the first year from the date of purchase, you pay for labor if you wish to have them installed.

- Stainless Steel Parts – 5 Years, no rust-through
- Painted Parts — 3 Years, no rust-through
- Cooking Grids — 2 Years, no rust-through

All warranty coverage excludes ignitor battery and grill part paint loss or rusting (except for rust-through as specified above), which are conditions that can be the result of normal use, accident or improper maintenance.

All warranty coverage is void if this grill is ever used for commercial or rental purposes.

All warranty coverage applies only if this grill is used in the United States.

This warranty gives you specific legal rights, and you may have other rights which vary from state to state.

Sears, Roebuck and Co.  
Hoffman Estates, IL 60179

© Sears Brands, LLC



## DANGER



### IF YOU SMELL GAS:

1. Shut off gas to the appliance.
2. Extinguish any open flame.
3. Open lid.
4. If odor continues, keep away from the appliance and immediately call your gas supplier or your fire department.

Leaking gas may cause a fire or explosion which could result in property damage, personal injury or death.



## WARNING



1. Do not store spare LP cylinder within 10 feet (3m) of this appliance.
2. Do not store or use gasoline or other flammable liquids and vapors within 25 feet (8m) of this appliance.
3. When cooking with oil/grease, do not allow the oil/grease to get hotter than 350°F (177°C).
4. Do not leave oil/grease unattended.



## WARNING



The Grease Draining Tray and Grease Receptacle must be visually inspected before each grill use. Remove any grease and wash Grease Draining Tray and Grease Receptacle with a mild soap and warm water solution. **Failure to comply with these instructions could result in a grease fire or explosion that could cause serious bodily injury, death or property damage.**



## WARNING



1. Always keep the Grease/Water Tray filled with water during operation. Failure to follow this could result in a grease fire that could cause serious bodily injury or property damage.
2. Handle this Grease/Water tray with a heat-resistant glove.

## Pre-Assembly Instructions For Your Safety

Congratulations on your selection of one of the finest outdoor kitchen appliances available, your Kenmore Infrared Technology Grill with lateral mount burners (patent pending) for optimum grilling performance.



Infrared technology grilling, because it heats the food directly and not the air around it, offers many advantages over conventional design steel tubular or cast iron burners:

- MORE FLAVORFUL FOOD** as the intense heat sears the food and locks in the juices while also cooking it faster which usually means more succulence.
- FEWER FLAREUPS** as the higher infrared heat vaporizes more drippings which also adds natural flavoring to your food.
- MORE EFFICIENCY AND CONVENIENCE** as the higher heat means shorter cooking times, more fuel efficiency and easier year round grilling.

To begin your "restaurant quality" grilling, become familiar with all of the cooking elements of your Kenmore grill. Review page 18 for lighting instructions and grill operation.

**IMPORTANT NOTE:** Your Kenmore infrared grill is equipped with an innovative Grease/Water Tray that is designed to trap excess grease drippings but also to moisturize your food. It is important to keep this tray filled with water while grilling in order to get the best possible results.

**WARNING:** Grease and water can get very hot. Always handle the Grease/Water Tray with a heat resistant glove. Before removing the Tray always be sure that the grill has properly cooled. Be aware that the tray does contain water and grease and be extremely careful when removing the tray to prevent spillage. Failure to follow these instructions could cause serious bodily injury or property damage.

**WARNING**

- LPG grill models must be used with Liquid Propane Gas and the regulator assembly supplied. Natural Gas models must be used with Natural Gas only. Any attempt to convert the grill from one fuel type to another is extremely hazardous and will void the warranty.
- **Never** use your gas grill in a garage, porch, shed, breezeway or any other enclosed area.
- **Never** obstruct the flow of ventilation air around your gas grill housing.
- **Never** disconnect the gas regulator or any gas fitting while your grill is lit. A lit grill can ignite leaking gas and cause a fire or explosion which could result in property damage, personal injury or death.
- Keep gas regulator hose away from hot grill surfaces and dripping grease. Avoid unnecessary twisting of hose. Visually inspect hose prior to each use for cuts, cracks, excessive wear or other damage. If the hose appears damaged do not use the gas grill. Call Sears at 1-800-4-MY-HOME<sup>®</sup> (1-800-469-4663) for a Sears replacement hose.

### PRE-ASSEMBLY

Read and perform the following pre-assembly instructions:

- Tools Required for Assembly** include:
  - protective work gloves
  - protective eyewear
  - #2 & #3 Phillips Head Screwdriver
- You will need assistance from another person to handle the grill head and other large, heavy parts.
- Open Lid of shipping carton and remove parts box and packing materials. Lay cardboard sheet on floor and use as a work surface to protect floor and grill parts from scratches.
- Slice all four corners with a utility knife to lay open the carton. This allows you to remove the grill head and components packed inside.
- Use the Hardware and Part Diagrams to ensure all items are included and free of damage.
- Do not assemble or operate the grill if it appears damaged. For repair or replacement parts that you need call anytime day or night

**1-800-4-MY-HOME (1-800-469-4663)**

### Grill Installation Codes

The installation must conform with local codes or, in the absence of local codes, with either the National Fuel Gas Code, ANSI Z223.1/NFPA 54, Natural Gas and Propane Installation Code, CSA B149.1, or Propane Storage and Handling Code, B149.2.

## Hardware Pack Parts List for 141.16671

PART #	PART DESCRIPTION	QTY	PURPOSE OF PART
P06001054A	Hardware Pack	1	For use in assembly of LPG Model 16671
S112G04081	Phillips Head Screw 1/4"x1/2"	8	Attaches Caster Seats to Cart Bottom Shelf
S112G03061	Phillips Head Screw 3/16"x3/8"	4	
S112G03081	Phillips Head Screw 3/16"x1/2"	4	Attaches Tank Holder to Cart Bottom Shelf
S313G03061	Flange Nut 3/16"	4	
S112G04081	Phillips Head Screw 1/4"x1/2"	4	Attaches Cart Side Panels to Caster Seats
S112G03061	Phillips Head Screw 3/16"x3/8"	8	
S112G03061	Phillips Head Screw 3/16"x3/8"	2	Attaches Door Guide Plate to Cart Bottom Shelf
S112G03061	Phillips Head Screw 3/16"x3/8"	4	Attaches Cart Rear Panel to Cart Side Panels
S313G03061	Flange Nut 3/16"	4	
S112G03061	Phillips Head Screw 3/16"x3/8"	2	Attaches Door Bracket between front Cart Legs
S112G03061	Phillips Head Screw 3/16"x3/8"	4	Attaches Door Hinge Brackets Lower to Cart Side Panels
S112G03061	Phillips Head Screw 3/16"x3/8"	4	Attaches Door Hinge Brackets Upper to Cart Side Panels
S112G03061	Phillips Head Screw 3/16"x3/8"	1	Attaches Cart Partition Panel Bracket to Cart Bottom Shelf
S112G03061	Phillips Head Screw 3/16"x3/8"	2	Attaches Cart Partition Panel Bracket to Cart Partition Panel
S112G03061	Phillips Head Screw 3/16"x3/8"	4	Attaches Cart Partition Panel to Cart Rear and Side Panel
S112G04191	Phillips Head Screw 1/4"x1-3/16"	4	Attaches Grill Bowl to Cart
S112G04081	Phillips Head Screw 1/4"x1/2"	8	Attaches Side Shelf Left and Side Burner Frame to Bowl Side Panel
S112G04081	Phillips Head Screw 1/4"x1/2"	4	
S313G04061	Flange Nut 1/4"	4	
S112G03061	Phillips Head Screw 3/16"x3/8"	2	Attaches Decorative Panel to Bowl Side Panel
P05536001A	Hose Holder	2	Attaches with Cart Rear Panel and Right Cart Side Panel
S112G03061	Phillips Head Screw 3/16"x3/8"	4	Attaches Hose Holder to Cart Rear Panel and Cart Side Panel
S313G03061	Flange Nut 3/16"	4	
P05515025L	Wrench	1	Tightens Casters
<b>Already installed on the Tank Holder</b>			
S233G03191	Wing Bolt 3/16"x1-3/16"	1	Secures Gas Tank to Tank Holder

# Hardware Pack Diagram for 141.16671

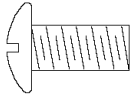

Phillips Head Screw 1/4"x1/2"  
Qty. 24  
Part # S112G04081



Phillips Head Screw 3/16"x3/8"  
Qty. 41  
Part # S112G03061

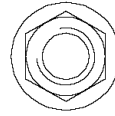

Flange Nut 3/16"  
Qty. 12  
Part # S313G03061

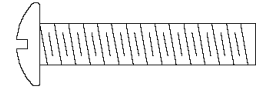

Phillips Head Screw 1/4"x1-3/16"  
Qty. 4  
Part # S112G04191



Flange Nut 1/4"  
Qty. 4  
Part # S313G04061

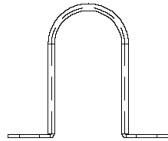

Hose Holder  
Qty. 2  
Part # P05536001A  
Scale 1:2

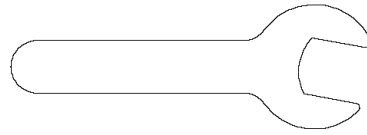

Wrench/No.17 Customized  
Qty. 1  
Part # P05515025L  
Scale 1:2

**Hardware already installed on the Tank Holder**

Wing Bolt 3/16"x1-3/16"  
Qty. 1  
Part # S233G03191

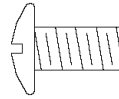

Phillips Head Screw 3/16"x1/2"  
Qty. 4  
Part # S112G03081

- \* One Battery/AA and One Battery/9V included in the Hardware Pack.
- \* One Battery/9V included in the Hardware Pack

# Parts Diagram for Model 141.16671

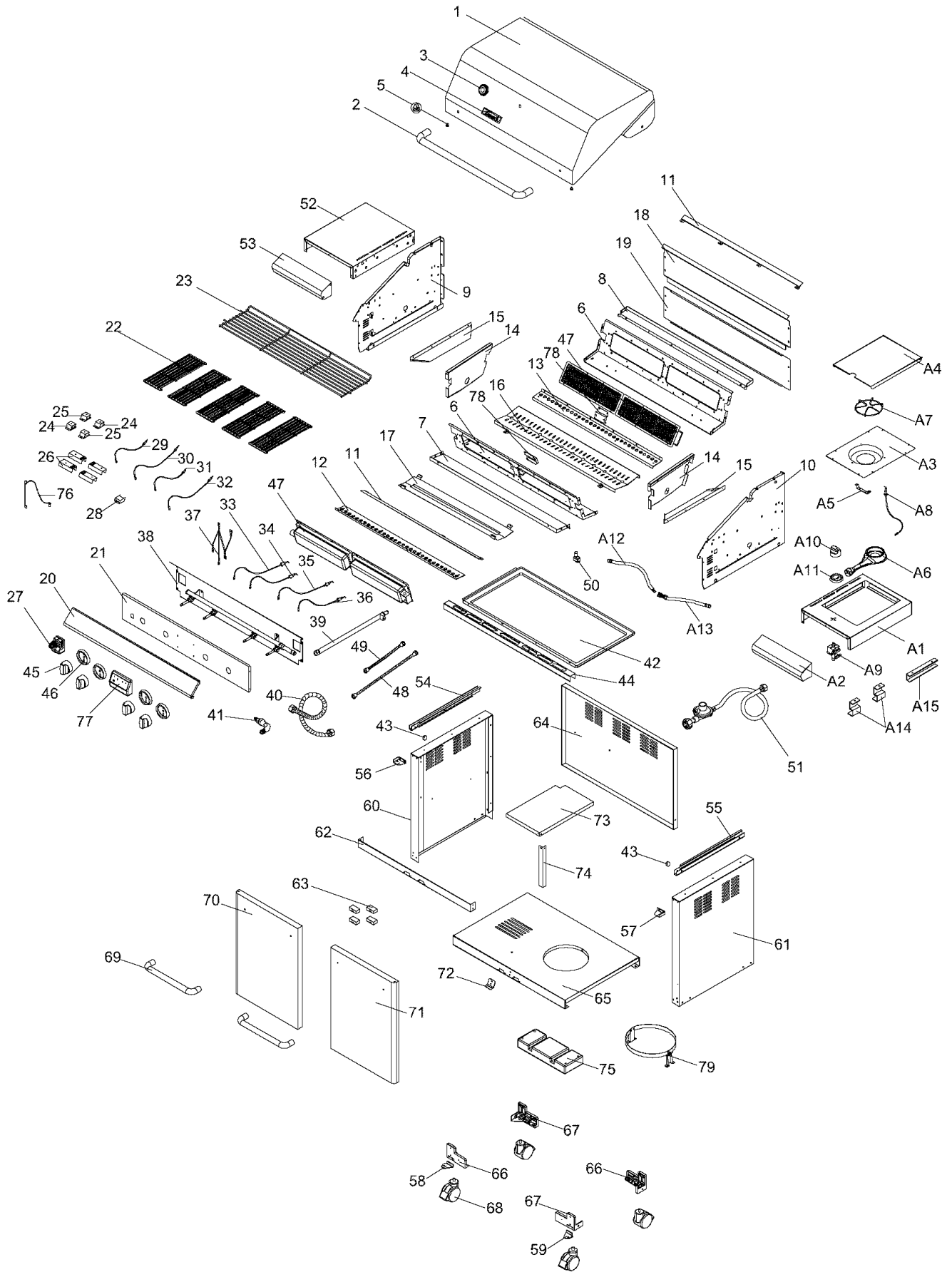

## Parts List for Model 141.16671

KEY	DESCRIPTION	PART #	QTY
1	Lid Assembly	P0014705EA	1
2	Lid Handle	P00205069B	1
3	Temperature Gauge	P00601071A	1
4	Name Plate	P00410041C	1
5	Protective Pad	P05518002I	2
6	Bowl Panel, Front/Rear	P0075401JA	2
7	Bowl Panel, Front Upper	P0075501JA	1
8	Bowl Panel, Rear Upper	P0075601JA	1
9	Bowl Panel, Left	P0072076EC	1
10	Bowl Panel, Right	P0072176EC	1
11	Grease Shield, Upper	P06902014C	2
12	Grease Shield, Lower Front	P06902015C	1
13	Grease Shield, Lower Rear	P06902016C	1
14	Grease Shield, Upper, Left/Right	P06901003A	2
15	Grease Shield, Lower, Left/Right	P06902017C	2
16	Heat Shield, Upper	P06901014A	1
17	Heat Shield, Lower	P06901015A	1
18	Bowl Panel, Rear/Upper	P06906025C	1
19	Bowl Panel, Rear	P06906026C	1
20	Control Panel, Upper	P02909351S	1
21	Control Panel	P02909361A	1
22	Cooking Grid	P01615028E	5
23	Cooking Rack/Secondary	P01516003A	1
24	Electrode Bracket, LF/RR	P03343001A	2
25	Electrode Bracket, RF/LR	P03343002A	2
26	Thermocouple Protector	P03343003A	4
27	Electric Ignitor, 4-port	P02502184C	1
28	Electric Ignitor Protector	P03343004A	1
29	Thermocouple, Blue Wire	P05305014A	1
30	Thermocouple, Red Wire	P05305015A	1
31	Thermocouple, White Wire	P05305016A	1
32	Thermocouple, Black Wire	P05305017A	1
33	Electrode with Wire, Left Front	P02618003C	1
34	Electrode with Wire, Left Rear	P02618004C	1
35	Electrode with Wire, Right Front	P02618005C	1
36	Electrode with Wire, Right Rear	P02618006C	1
37	Electric Wire Set, 4 contact	P02615099A	1
38	Gas Valve/Manifold Assembly	Y0060398	1
39	Gas Manifold	P03708001C	1
40	Manifold Connector	P03715005A	1
41	Connector With Infrared Orifice	P06536002A	4
42	Grease/Water Tray	P02717184A	1
43	Wheel for Grease Tray	P05354002A	4
44	Grease Tray Handle	P02720023C	1
45	Control Knob	P03428073H	4
46	Control Knob Seat	P03413011J	4
47	Infrared Burner Assembly	P02005009A	4
48	Gas Connector, Rear	P03701013A	2
49	Gas Connector, Front	P03701014A	2
50	Gas Fitting	P03906003A	1
51	Regulator with Hose	P03601039A	1
52	Side Shelf, Left	P01106009B	1
53	Decorative Panel for Side Shelf, Left	P07503007A	1
54	Bowl Support Bracket, Left	P01301008A	1
55	Bowl Support Bracket, Right	P01302008A	1

## Parts List for Model 141.16671

KEY	DESCRIPTION	PART #	QTY
56	Door Hinge Bracket, Upper Left	P03302014C	1
57	Door Hinge Bracket, Upper Right	P03302015C	1
58	Door Hinge Bracket, Lower Left	P03302025A	1
59	Door Hinge Bracket, Lower Right	P03302026A	1
60	Cart Leg with Side Panel, Left	P07614009A	1
61	Cart Leg with Side Panel, Right	P07615009A	1
62	Door Bracket	P03306027C	1
63	Door Magnet	P05523005M	4
64	Cart Rear Panel	P07701069A	1
65	Cart Bottom Shelf	P01009011C	1
66	Caster Seat, LF/RR	P05327039Q	1
67	Caster Seat, RF/LR	P05327040Q	1
68	Caster, 3 in., with Brake	P05106005A	4
69	Door Handle	P00205073M	2
70	Door, Left	P04302041A	1
71	Door, Right	P04303041A	1
72	Door Guide Plate	P05510020A	1
73	Cart Partition Panel	P07512007D	1
74	Cart Partition Panel Bracket	P03303025J	1
75	Weight	P05344003Q	2
76	Lighting Stick	P05313009B	2
77	Burner Indicator Display	P05357001H	1
78	Gas Collector Box	P02212087D	2
79	Tank Holder	P05358001G	1
A1	Side Burner Frame	P01108013B	1
A2	Decorative Panel for Side Burner Frame	P07502017A	1
A3	Side Burner Body	P02301020B	1
A4	Side Burner Lid	P01127004B	1
A5	Side Burner Bracket	P03327037C	1
A6	Side Burner with Brass Ring	P02002012A	1
A7	Side Burner Pot Support	P00805010A	1
A8	Side Burner Electrode	P02614014C	1
A9	Side Burner Gas Valve	Y0060399	1
A10	Side Burner Control Knob	P03401013H	1
A11	Side Burner Control Knob Seat	P03408051J	1
A12	Side Burner Connection Hose, Plug	P03705049H	1
A13	Side Burner Connection Hose, Socket	P03705050E	1
A14	Side Burner Connection Hose Bracket	P03341001C	2
A15	Side Burner Heat Shield	P06907001M	1
	Hardware Pack	P06001054A	1
	Operator's Manual	P80102004L	1

For the repair or replacement parts you need:

Call anytime **1-800-4-MY-HOME®** (1-800-469-4663)

To obtain the correct replacement parts for your gas grill, please refer to the part numbers in this parts list. The following information is required to ensure you receive the correct parts:

1. Model and Serial Number (see CSA label on grill)
2. Part Number
3. Part Description
4. Quantity of parts needed

**Important:** Use only Sears replacement parts. The use of any part that is not a Sears replacement part can be dangerous and will also void your product warranty. Keep this Operator's Manual for convenient referral and for part replacement.



# Assembly Instructions

## 1

### Install Caster Seats

- Install the Caster Seats (LF/RR and RF/LR) to Left and Right Cart Side Panels using 4 Phillips Head Screws 1/4" x 1/2" and 8 Phillips Head Screws 3/16" x 3/8".

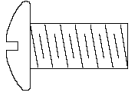

Phillips Head Screw 1/4"x1/2"  
Qty. 4  
Part # S112G04081



Phillips Head Screw 3/16"x3/8"  
Qty. 8  
Part # S112G03061

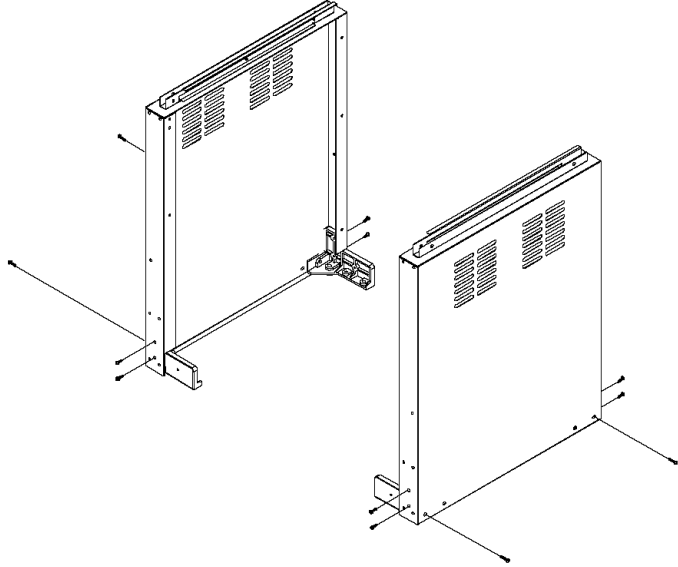

## 2

### Install Cart Side Panels to Cart Bottom Shelf

- Install Cart Bottom Shelf to Caster Seats using 8 Phillips Head Screws 1/4" x 1/2" and 4 Phillips Head Screws 3/16" x 3/8". Do not fully tighten at this time; Tighten securely only after Rear Panel and Lower Door Brackets are attached.  
**(NOTE: Be sure that the tank hole is positioned to the right).**
- Install the Door Guide Plate to Cart Bottom Shelf using 2 Phillips Head Screws 3/16" x 3/8".

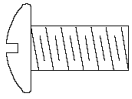

Phillips Head Screw 1/4"x1/2"  
Qty. 8  
Part # S112G04081



Phillips Head Screw 3/16"x3/8"  
Qty. 6  
Part # S112G03061

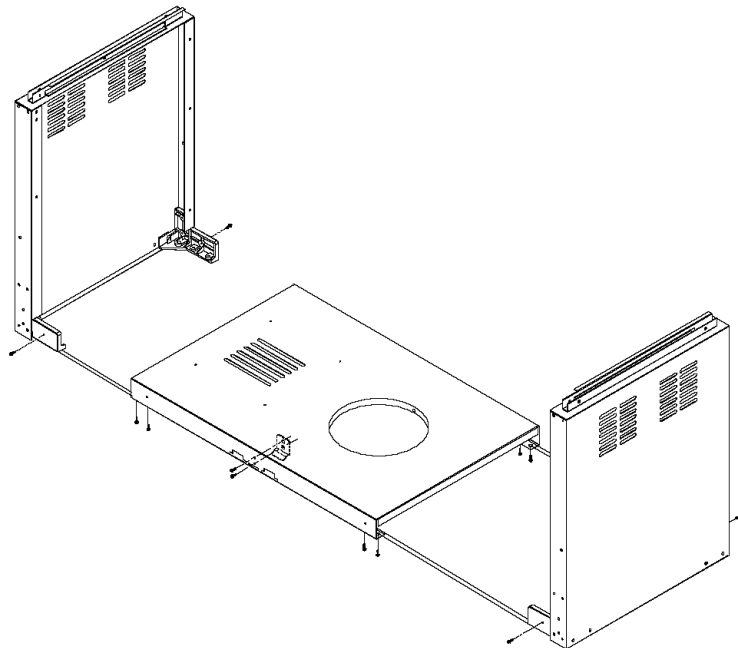

### 3

#### Install Tank Holder to Cart Bottom Shelf

- Align the 4 holes (2 on either side) of the Tank Holder Bracket with the holes on the Cart Bottom Shelf and insert 4 Phillips Head Screws 3/6" x 1/2" as shown.
- Secure Cart Bottom from the underside using 4 Flange Nuts 3/16".  
Note: When installing tank, remove Wing Bolt on Tank Holder to unclamp the 2 Arm Rims. Place Holder over Tank, then reclamp the Arm Rims back together using Wing Bolt and tighten securely.
- Install 4 Casters onto Caster Seats.

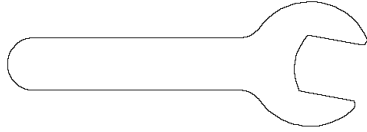

Wrench/No.17 Customized  
Qty. 1  
Part # P05515025L  
Scale 1:2

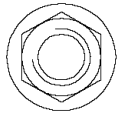

Flange Nut 3/16"  
Qty. 4  
Part # S313G03061

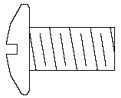

Phillips Head Screw 3/16"x1/2"  
Qty. 4  
Part # S112G03081

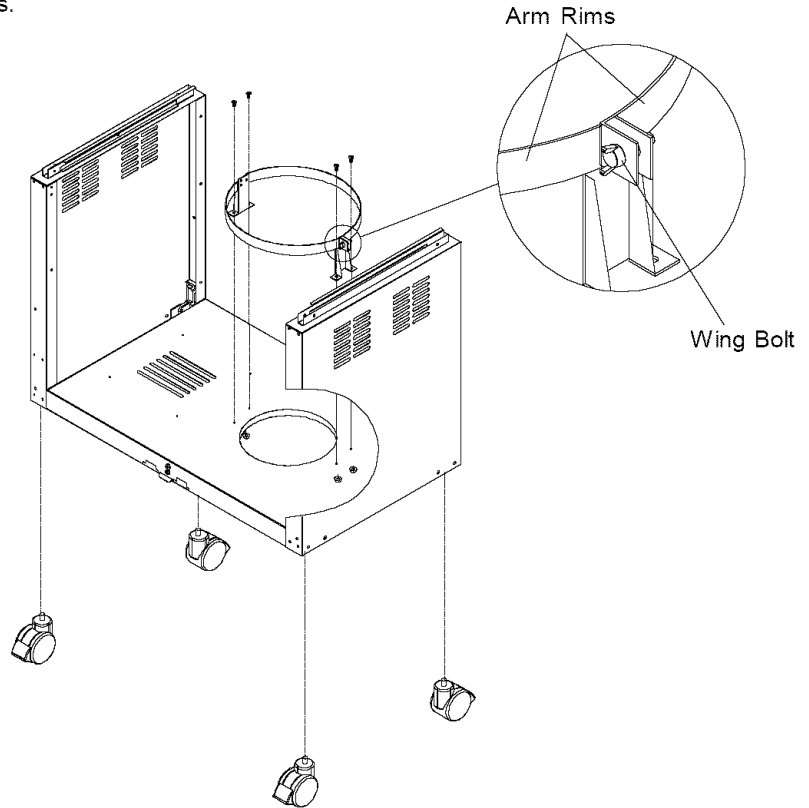

### 4

#### Install Cart Rear Panel and Door Brackets

- Install the Cart Rear Panel between Rear Cart Legs as shown using 4 Phillips Head Screws 3/6" x 3/8" and 4 Flange Nuts 3/16".
- Install the Door Bracket in the up position between Front Cart Legs as shown.
- Install the Lower Door Hinge Brackets to Lower Cart Side Panels and tighten securely.



Phillips Head Screw 3/16"x3/8"  
Qty. 10  
Part # S112G03061

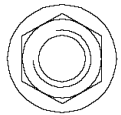

Flange Nut 3/16"  
Qty. 4  
Part # S313G03061

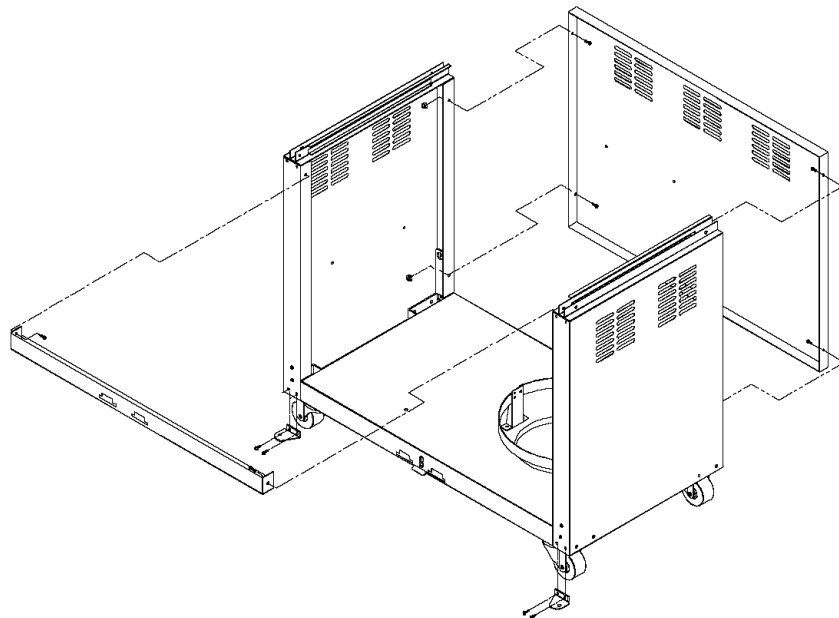

## 5

### Install Partition Panel

- Install the Partition Panel to Left Cart Side Panel and Cart Rear Panel.
- Install the Partition Panel Bracket between Partition Panel and Cart Bottom Shelf.



Phillips Head Screw 3/16"x3/8"  
Qty. 7  
Part # S112G03061

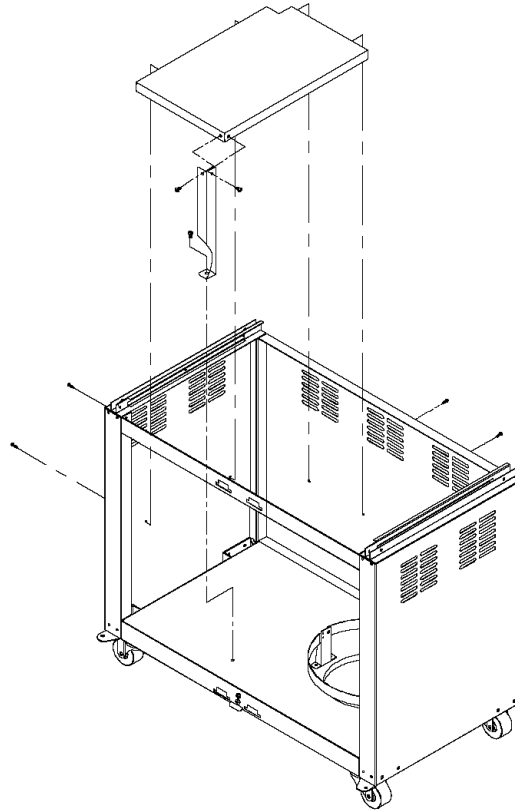

## 6

### Install Left and Right Door and Top Door Hinge Brackets

- Remove preassembled screws from Door Handle and install Door Handle to Left Door.
- Install the Left Top Door Hinge Bracket to Left Cart Leg using 2 Phillips Head Screws 3/16"x3/8".
- Place the Door Bottom onto Bottom Left Door Hinge Bracket. Push down on the Spring Lever mechanism on the Top Left Door Hinge and position the Door into the Top Left Door Hinge Bracket. Release the spring lever to lock into Top Door Hinge Bracket.
- Repeat for Right Door.



Phillips Head Screw 3/16"x3/8"  
Qty. 4  
Part # S112G03061

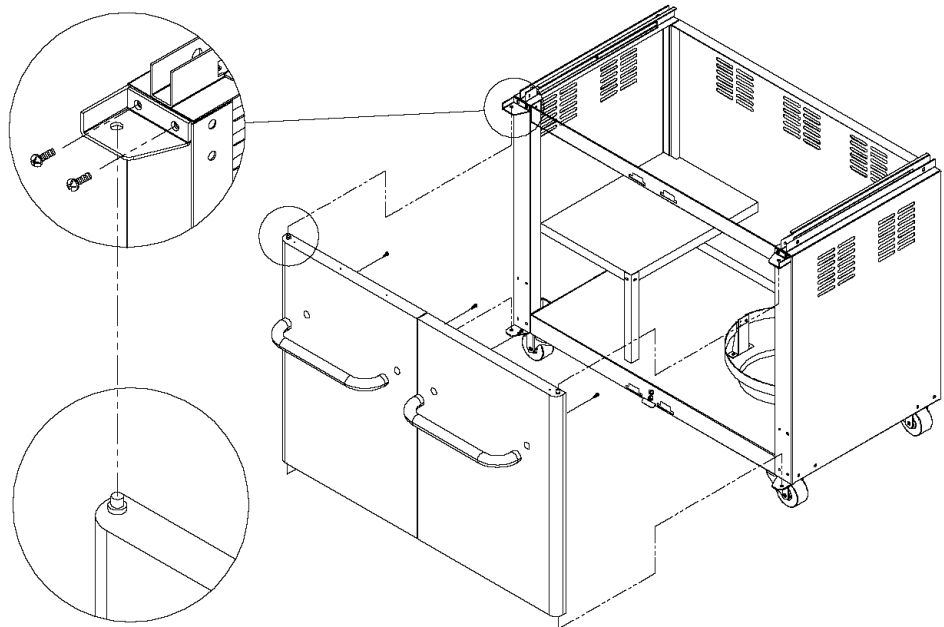

# 7

## Install Grill Bowl

- Remove cooking components from Grill Head. With an assistant, lift and position Grill Head on the Cart.
- Tighten securely using screws S112G04191.

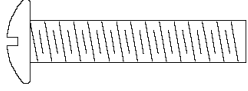

Phillips Head Screw  
1/4"x1-3/16"  
Qty. 4  
Part # S112G04191

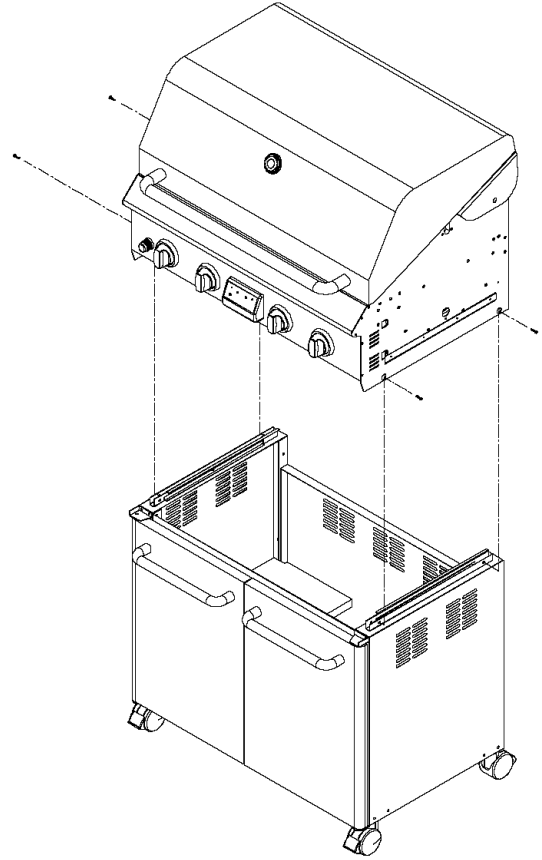

# 8

## Install Regulator Assembly

- Open the right door and Place the Regulator with Hose (LPG) inside the cart through the opening above Cart Rear Panel. Secure the Regulator with Hose (LPG) onto Cart Rear Panel and Cart Right Panel using the Hose Holder, Screws and Nuts provided.



Phillips Head Screw 3/16"x3/8"  
Qty. 4  
Part # S112G03061

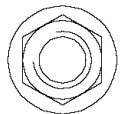

Flange Nut 3/16"  
Qty. 4  
Part # S313G03061

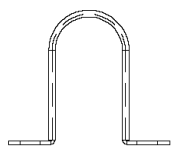

Hose Holder  
Qty. 2  
Part # P05536001A  
Scale 1:2

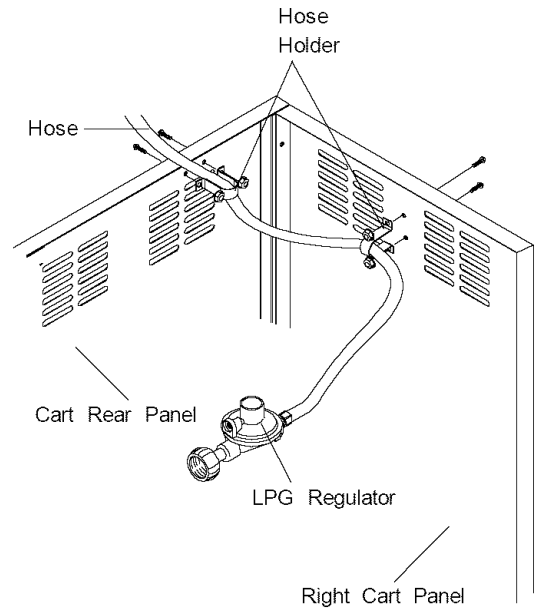
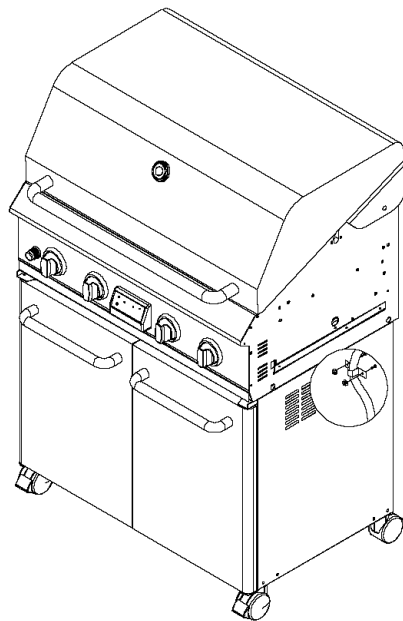

## 9

### Install Side Shelf and Side Burner Frame and Grease/Water Tray

- ☐ Position Side Shelf over the Left Bowl Panel and Side Burner Frame over the Right Bowl Panel and tighten securely using Screws and Nuts provided.
- ☐ Secure Decorative Panel to Bowl Side Panel using Phillips Head Screw 3/16"x3/8".
- ☐ From the front of the grill, slide the assembled Tray side tabs over the side rails underneath the Grill Bowl.

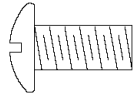

Phillips Head Screw 1/4"x1/2"  
Qty. 12  
Part # S112G04081



Flange Nut 1/4"  
Qty. 4  
Part # S313G04061

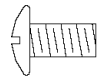

Phillips Head Screw 3/16"x3/8"  
Qty. 2  
Part # S112G03061

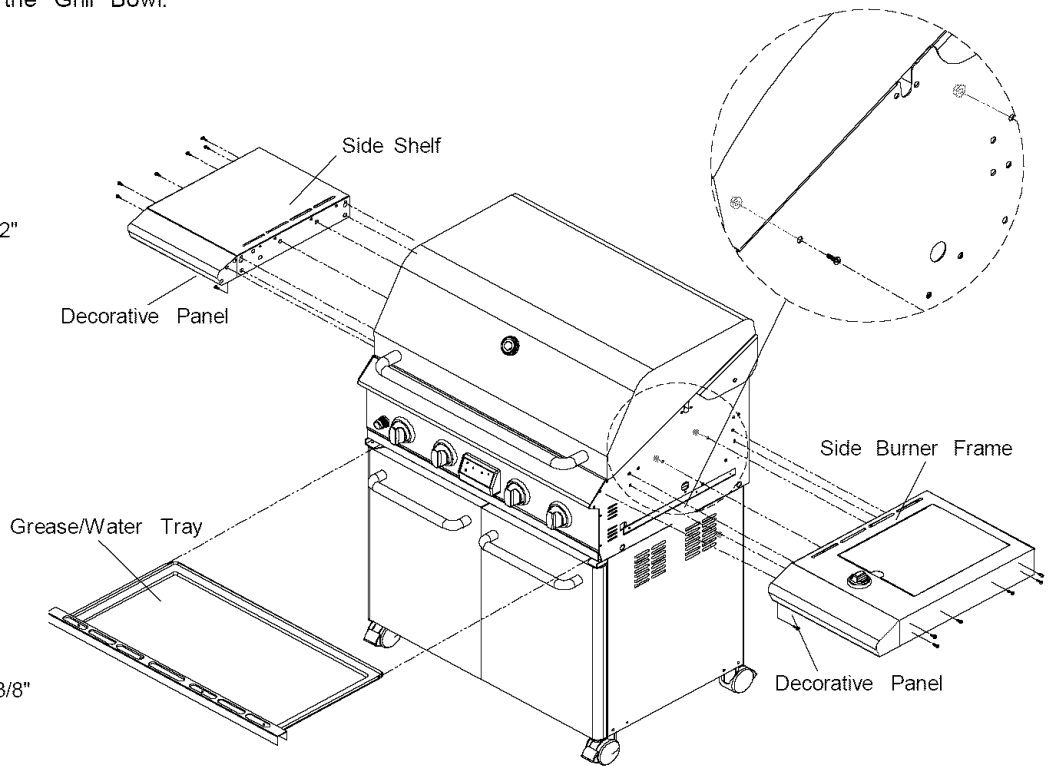

## 10

### Install Side Burner Connection Hose

- ☐ Push back Sleeve of the Socket. See Figure A. Insert Plug then release Sleeve. See Figure B. Push Plug until sleeve snaps forward locking the Plug into the Socket. See Figure C.
- ☐ Push the Side Burner Hose into hose holder.

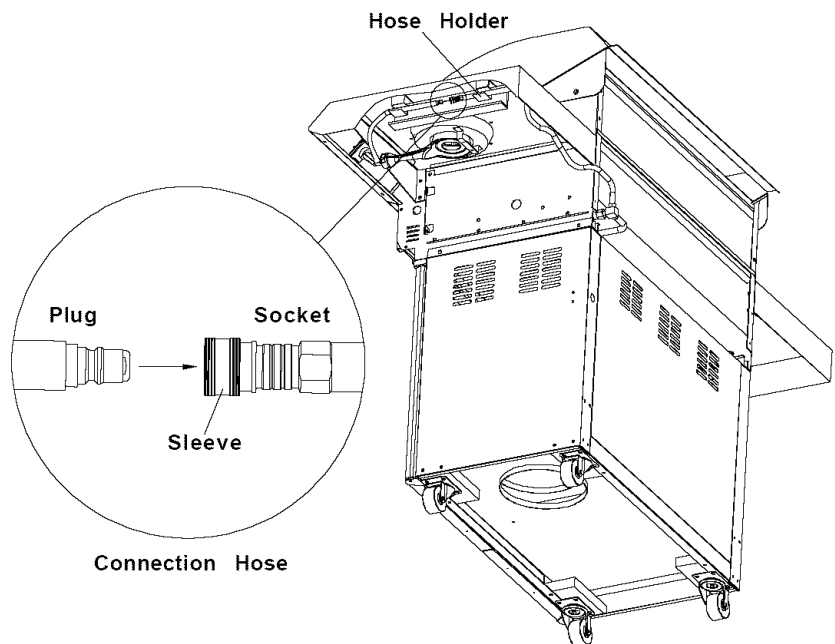
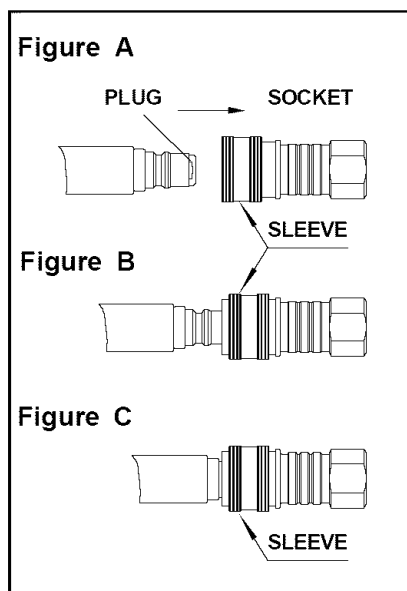

## 11

### Install Ignitor Battery

- Unscrew Ignitor Cap from Control Panel.
- Place supplied AA battery into the Ignitor Slot with positive pole facing you.
- Position the Cap and Spring over the AA battery and tighten onto Control Panel.

## 12

### Main Burners Electrode Check Perform this Electrode Check with the assistance of another person.

This test will ensure that the Spark Electrode Tips are properly positioned so your grill lights easily and properly.

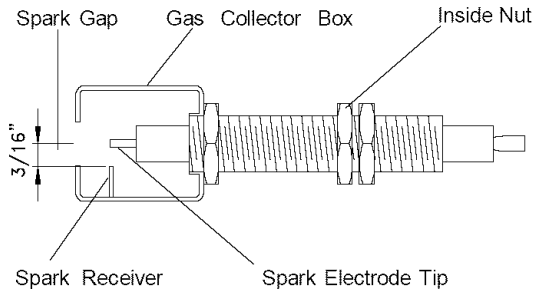

- Be sure all Control Knobs are set to "OFF" and open the Grill Lid.
- Have your assistant stand behind to the right of the grill and look toward the front of the grill bowl. **Never** put your face inside the Grill Bowl.
- Press the Ignitor Cap. You should hear a "clicking" sound. Your assistant should see a blue spark within each Gas Collector Box. If a spark is present the Electrode Tips are properly positioned.
- If no spark is seen, the Spark Gap needs to be adjusted as follows:
  - Using an adjustable wrench, loosen the Inside Nut until the Gas Collector Box can be turned upward.
  - If the gap between the Spark Electrode Tip and Receiver is more than 3/16" use long nose pliers to gently squeeze the Gas Collector Box to narrow gap.
  - Return the Gas Collector Box to its original position, secure the Inside Nut and try the Electrode Check again. If no "clicking" sound is heard:
    - AA Battery may be installed backwards.
    - Electric wires may be loose. Remove the AA Battery and inspect the Ignitor Junction Box found behind the Control Panel and reconnect any loose wires.

## 13

### Side Burner Electrode Check

- Open side burner lid. Remove plastic shipping band from burner and pot support.
- Push and turn side burner Control Knob to HIGH. Look for spark between tip of electrode and burner.
- If you don't see a spark from side burner electrode, adjust gap between electrode and burner surface to 3/16 in.

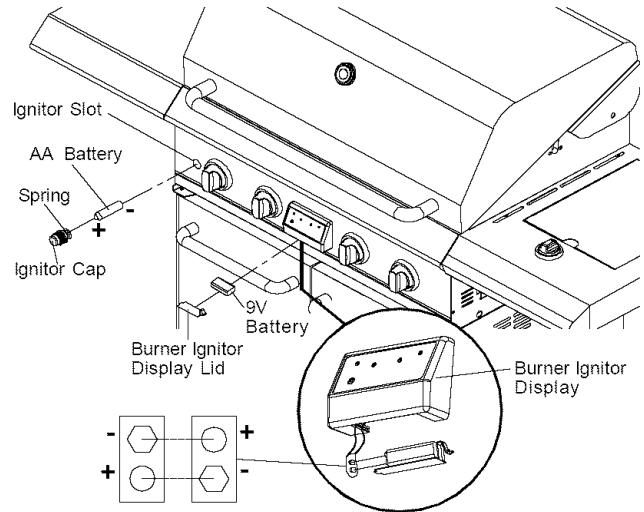

## 14

### Install Burner Ignitor Display Battery

- Remove lid casing under Burner Selector Display box and install one 9V Battery. Then replace the lid.

## 15

### Install Cooking Components

- Place Cooking Grids on bowl ledge.
- Place the Secondary Cooking Rack into the slots on Grill Bowl Side Panels.

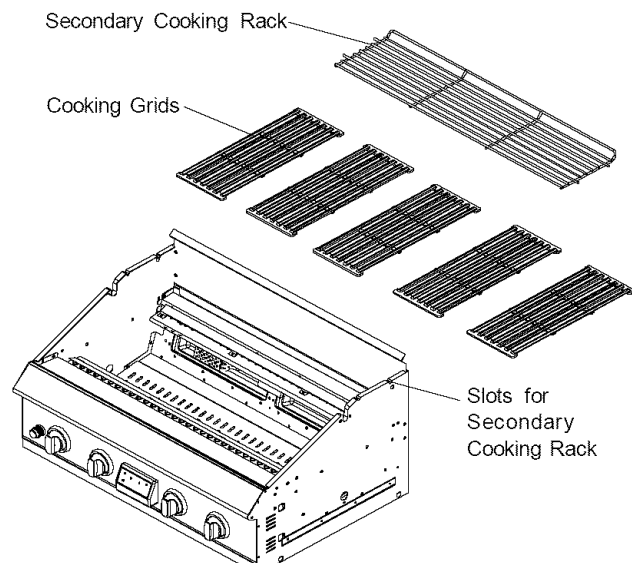

## Final Grill Assembly Step

When you have finished assembling your grill be sure that all screws are tightened for safe operation of your grill.

Before each use of the grill, the Grease/Water Tray should be filled approximately 1/2 full with water and carefully fully seated under the grill bowl.



**CAUTION:** The Grease/Water Tray should be inspected before each grill use to be sure there is no excessive grease buildup. Clean the tray regularly and as needed.

# LP Gas Tank Installation

## CORRECT LP GAS TANK USE

- LP Gas grill models are designed for use with a standard 20 lb. Liquid Propane Gas (LP Gas) tank, not included with grill. **Never** connect your gas grill to an LP Gas tank that exceeds this capacity. A tank of approximately 12 inches in diameter by 18-1/2 inches high is the maximum size LP Gas tank to use. **You must use an "OPD" gas tank which offers a listed Overfill Prevention Device.** This safety feature prevents tank from being overfilled which can cause malfunction of LP Gas tank, regulator and/or grill.
- The LP Gas tank must be constructed and marked in accordance with the Specifications for LP-Gas Cylinders of the U.S. Department of Transportation (D.O.T.) or the National Standard of Canada, CAN/CSA-B339, Cylinders, Spheres and Tubes for Transportation of Dangerous Goods; and Commission, as applicable.
- The LP Gas tank must have a shutoff valve, terminating in an LP Gas supply tank valve outlet, that is compatible with a Type 1 tank connection device. The LP Gas tank must also have a safety relief device that has a direct connection with the vapor space of the tank.
- The tank supply system must be arranged for vapor withdrawal.
- The LP Gas tank used must have a collar to protect the tank valve.
- Never** connect an unregulated LP gas tank to your gas grill. The gas regulator assembly supplied with your gas grill is adjusted to have an outlet pressure of 11" water column (W.C.) for connection to an LP gas tank. Only use the regulator and hose assembly supplied with your gas grill. **Replacement regulators and hose assemblies must be those specified by Sears.** See Parts List.
- Have your LP Gas dealer check the release valve after every filling to ensure it remains free of defects.
- Always keep LP Gas tank in upright position.
- Do not subject the LP Gas tank to excessive heat.
- Never store an LP Gas tank indoors. If you store your gas grill in the garage **always** disconnect the LP Gas tank first and store it safely outside.
- LP Gas tanks must be stored outdoors in a well-ventilated area and out of the reach of children.
- Disconnected LP Gas tanks must not be stored in a building, garage or any other enclosed area.
- The regulator and hose assembly can be seen after opening the doors (if applicable) and must be inspected before each use of the grill. If there is excessive abrasion or wear or if the hose is cut, it must be replaced prior to using the grill again.
- Never** light your gas grill with the lid closed.
- Never** allow children to operate your grill. Do not allow children or pets to play near your grill.



- Use of alcohol or drugs may impair the ability to assemble and operate the appliance.
- Keep fire extinguisher readily accessible. In the event of a oil/grease fire, do not attempt to extinguish with water. Use type B extinguisher or smother with dirt, sand or baking soda.
- In the event of rain, cover the grill and turn off the burner and gas supply.
- Use your grill on a level, stable surface in an area clear of combustible materials.
- Do not leave grill unattended when in use.
- Do not move the appliance when in use.
- Allow the grill to cool before moving or storing.
- Do not use your grill as a heater.
- This grill is not intended to be installed in or on recreational vehicles and/or boats.

**WARNING**

A. Do not store a spare LP-Gas tank under or near this appliance.

B. Never fill the tank beyond 80 percent full; and

C. If the information in "(a)" and "(b)" is not followed exactly, a fire causing death or serious injury may occur.

**WARNING**

- **Use your grill at least 5 feet away from any wall or surface** Use your grill at least **5 feet away** from combustible objects that can melt or catch fire (such as vinyl or wood siding, fences and overhangs) or sources of ignition including pilot lights on water heaters and live electrical appliances.
- **Never** use your gas grill in a garage, porch, shed, breezeway or any other enclosed area.
- **Never** obstruct the flow of ventilation air around your gas grill housing.

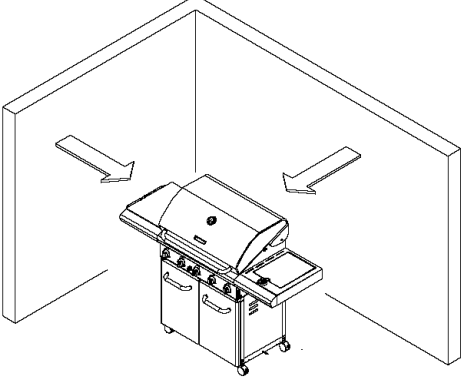

## NOTE about LP Gas Tank Exchange Programs

- Many retailers that sell grills offer you the option of replacing your empty LP Gas tank through an exchange service. Use only those reputable exchange companies that inspect, precision fill, test and certify their tanks. Exchange your tank only for an OPD safety feature-equipped tank as described in the LP Gas tank section of this manual.
- Always keep new and exchanged LP Gas tanks in an upright position during use, transit or storage.
- Leak test new and exchanged LP Gas tanks BEFORE connecting one to your grill.

## How to Leak Test your LP Gas Tank

### For your safety:

- All leak tests must be repeated each time your LP Gas tank is exchanged or refilled.
- When checking for gas leaks do not smoke.
- Do not use an open flame to check for gas leaks.
- Your grill must be leak tested outdoors in a well-ventilated area, away from ignition sources such as gas fired or electrical appliances. During the leak test, keep your grill away from open flames or sparks.
- Do not use household cleaning agents. Damage to gas assembly components can result.
  - Use a clean paintbrush and a 50/50 mild soap and water solution.
  - Brush soapy solution onto LP Gas tank in the areas indicated by the arrows. See diagram.
  - If growing bubbles appear do not use or move the LP Gas tank. Call an LP Gas Supplier or your Fire Department.

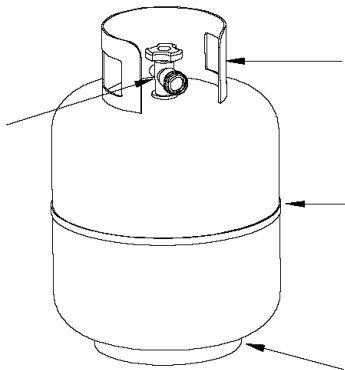

## To Install LP Gas Tank (LPG model only): Secure a 20lb LP Gas Tank to Gas Grill

- Turn your LP Gas Tank Valve clockwise to the closed or OFF position.
- Loosen the Wing Bolt on the Tank Holder located on the bottom shelf.
- Place LP Gas tank into Tank Holder. Be sure bottom of tank fully rests in cutout in bottom shelf.
- Install the tank so the Tank Valve faces the right side of cabinet.
- Secure Gas Tank by tightening Wing Bolt.

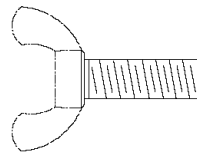
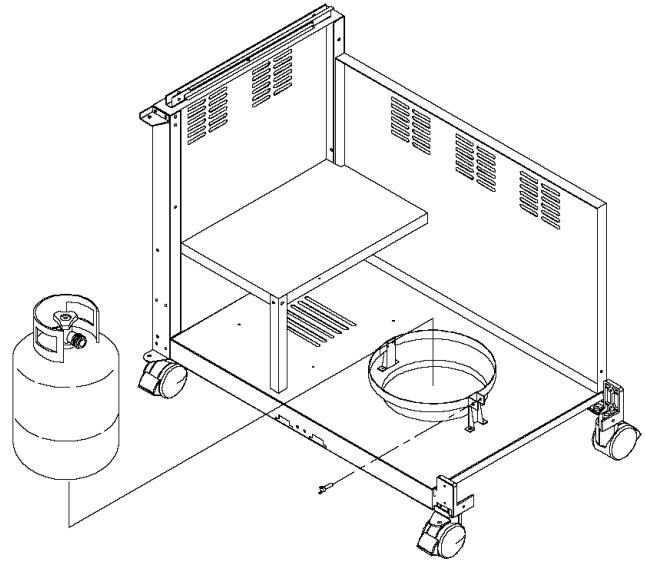

**The Nut is fixed to Tank Holder . The Wing Bolt is secured AFTER inserting tank into tank hole.**

Wing Bolt 3/16"x1-3/16"  
Qty. 1  
Part # S233G03191

	<b>WARNING</b>	
If growing bubbles appear do not use or move the LP Gas tank. Contact an LP Gas Supplier or your fire department!		

**NOTE:** Many different size propane gas tank bottom collars are available in the market, especially with the popularity of tank exchange programs. If your tank bottom collar does not fit into the tank hole after attaching the special nut to the wing bolt, simply remove the special nut and secure the tank using the wing bolt only.



### LP Gas Model only:

#### Connect Regulator with Hose to your LP Gas Tank

- Turn all Burner Valves to the OFF position.
- Inspect the valve connection port and regulator assembly for damage or debris. Remove any debris. Never use damaged or plugged equipment.
- Connect the regulator assembly to the tank valve and HAND TIGHTEN nut clockwise to a full stop. DO NOT use a wrench to tighten because it could damage the Quick Coupling Nut and result in a hazardous condition.
- Open the tank valve 1/4 to 1/2 (counterclockwise) and use a soapy water solution to check all connections for leaks before attempting to light your grill. See "Checking for LP Gas Leaks". If a leak is found, turn the tank valve off and do not use your grill until the leak is repaired.

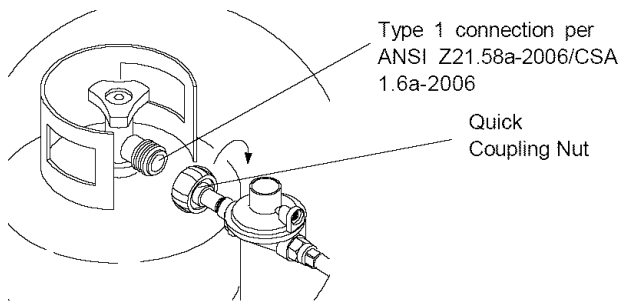

**CAUTION:** When the appliance is not in use the gas must be turned off at the tank.

#### Check all connections for LP Gas Leaks

Never test for leaks with a flame. Prior to first use, at the beginning of each season, or every time your LP Gas tank is changed, you must check for gas leaks. Follow these three steps:

- Make a soap solution by mixing one part liquid detergent and one part water.
- Turn the grill Control Knobs to the full OFF position, then turn the gas ON at source.
- Apply the soap solution to all gas connections indicated by the arrows. See diagram. If bubbles appear in the soap solution the connections are not properly sealed. Check each fitting and tighten or repair as necessary.

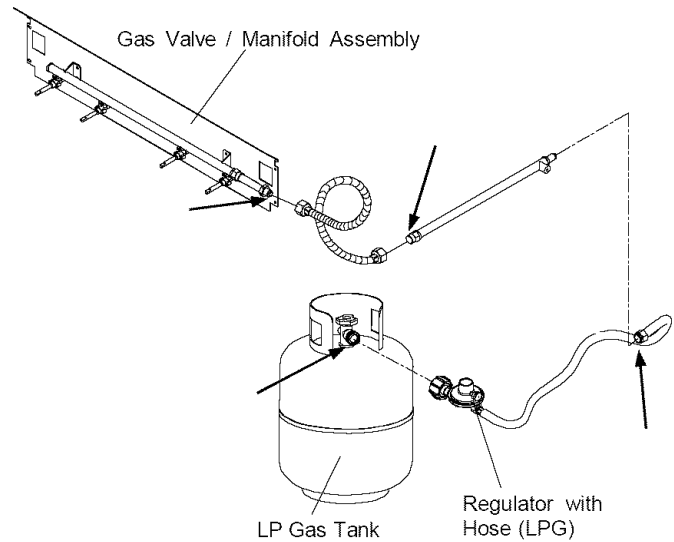

	<b>WARNING</b>	
<p>If you have a gas leak that cannot be repaired by tightening, turn off the gas at the source, disconnect fuel line from your grill and call 1-800-4-MY-HOME® or your gas supplier for repair assistance.</p>		

#### Disconnecting A Liquid Propane Gas (LPG) Tank From Your Grill



- Make sure the Burner Valves and LP Gas tank valve are off. (Turn clockwise to close.)
- Detach the hose and regulator assembly from the LP Gas tank valve by turning the Quick Coupling Nut counterclockwise.

	<b>WARNING</b>	
<p>Failure to read and follow the Use and Care Instructions could result in a fire or explosion that could cause serious bodily injury, death or property damage.</p>		

# USE AND CARE INSTRUCTIONS

## Grill Lighting Instructions

- Before each use, check all hoses for cracks, nicks, cuts, burns or abrasions. If a hose is damaged in any way, do not use grill before replacing hose with identical part from Parts List. Also, make sure all gas supply connections are securely tightened.
- Familiarize with the safety and Use and Care instructions in this manual. Do not smoke while lighting grill or checking gas supply connections.
- Be sure the LP Gas tank is filled.

**WARNING**

Failure to replace a faulty hose, secure gas supply connections or to open the grill lid before proceeding to light grill could result in a fire or explosion that could cause serious injury, death, or property damage.

## To Light grill

1. Open the Grill Lid.
2. Set Control Knobs to OFF and open the LP Gas Tank valve **SLOWLY 1/4 of a turn**.

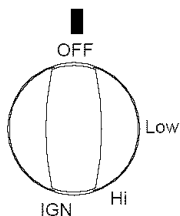

Open LP Gas tank

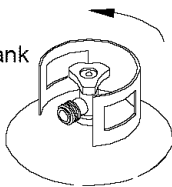

3. Press the Power Button to turn on the Burner Indicator Display.

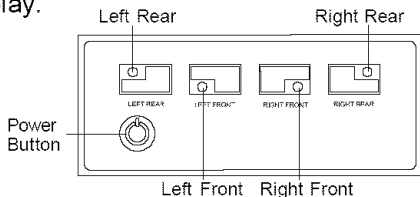

4. Push and turn desired burner Control Knob to IGN and hold it in 3 - 5 seconds to ignite.

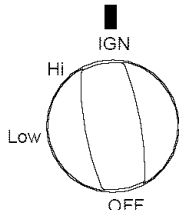

5. Check Display to see if desired burner indicator lights up in about 10 seconds. If indicator lights up, turn Control Knob away from IGN to HIGH.
6. If burner indicator does not light up in about 10 seconds, turn Control Knob and gas source OFF, wait 5 minutes for gas to clear, and repeat lighting procedure.
7. Once desired burner is lit, light adjacent burners by turning knobs to HIGH.  
NOTE: If Burner Indicator Display does not turn ON after pressing Power Button, check battery housed under Display casing.



## Side Burner Lighting Instructions

1. Follow steps 1 through 5 of the Grill Lighting Instructions.
2. Open Side Burner Lid.
3. Set Control Knobs to OFF and open the LP Gas tank valve **SLOWLY 1/4 of a turn**.
4. Push and turn the Control Knob to HIGH. ⚡  
The built-in spark ignitor will light the Burner automatically.
5. You may have to push and turn the Control Knob up to 3 or 4 times to light.
6. If ignition does not occur, turn gas off at source and turn Control Knobs OFF. Wait at least 5 minutes for gas to clear, then retry. If your grill still fails to light turn the burner Control Knob and gas source OFF and conduct a leak test of ALL gas connections and fuel sources. If no leaks are detected, wait 5 minutes for any gas to clear and repeat the lighting procedure.

## Manually Lighting Your Grill By Paper Match

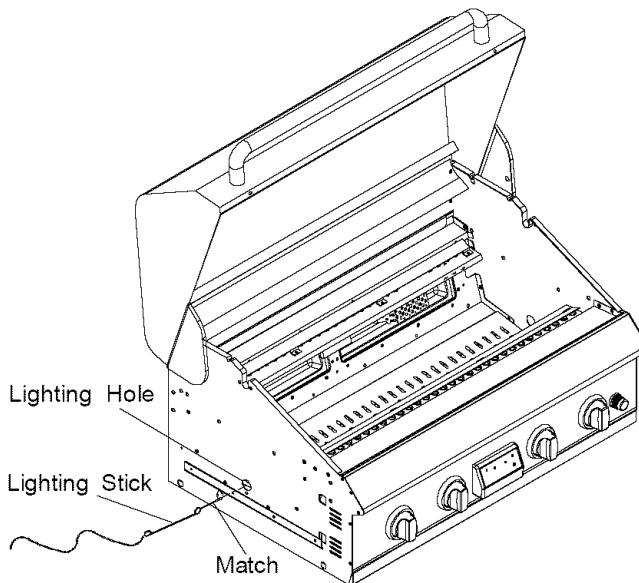
To light your gas grill by match, insert a match into the Lighting Stick and follow steps 1 through 6 of the Grill Lighting Instructions. Then, light the match and place Lighting Stick through the Lighting Hole on the left side of the grill as shown below. Turn the nearest Control Knob to the HIGH setting to release gas. The Burner should light immediately.



**WARNING**

**Never** lean over the grill cooking area while lighting your gas grill. Keep your face and body a safe distance (at least 18 inches) from the Lighting Hole or Burners when lighting your grill by match.

## USE AND CARE INSTRUCTIONS



### Troubleshooting

#### If the grill fails to light :

1. Turn gas off at source and turn Control Knobs to OFF. Wait at least 5 minutes for gas to clear, then retry.
2. If your grill still fails to light, check gas supply and connections.
3. Repeat lighting procedure. If your grill still fails to operate, turn the gas off at source, turn the Control Knobs to OFF, then check the following:
  - Obstruction in gas line  
**Correction:** Remove regulator hose from grill. Do not smoke! Open gas supply for one second to clear any obstruction from fuel line. Close off gas supply at source and reconnect fuel line to grill.
  - Disconnected Electric Wires  
**Correction:** Inspect the Electric Ignitor (see Parts List) found behind the Control Panel. Connect loose Electric wires to Junction Box and try to light the grill.
  - Weak AA battery  
**Correction:** Unscrew the Ignitor Cap and replace the battery.
  - If the grill still does not light you may need to purge air from the gas line or reset the regulator excess gas flow device. **Note:** This procedure should be done every time a new LP Gas tank is connected to your grill.

#### To purge air from your gas line and/or reset the regulator excess gas flow device:

- Turn Control Knobs to the OFF position.
- Turn off the gas at the tank valve.
- Disconnect regulator from LP Gas tank.
- Let unit stand 5 minutes to allow air to purge from gas line.
- Reconnect regulator to the LP Gas tank.
- Turn tank valve on SLOWLY 1/4 of a turn.
- Open the Grill Lid.
- Push and turn the Control Knob to IGN and hold it in 3-5 seconds to ignite the burner.

	<b>WARNING</b>	
<p>Should a FLASHBACK fire occur in or around the Burner Tubes, follow the instructions below. Failure to comply with these instructions could result in a fire or explosion that could cause serious bodily injury, death, or property damage.</p> <ul style="list-style-type: none"><li>• Shut off gas supply to the gas grill.</li><li>• Turn the Control Knobs to OFF position.</li><li>• Open the Grill Lid.</li><li>• Put out any flame with a Class B fire extinguisher.</li></ul>		

For repair or replacement parts that you need call anytime day or night

1-800-4-MY-HOME<sup>®</sup> (1-800-469-4663)

## CLEANING AND MAINTENANCE

Proper care and maintenance will keep your grill in top operating condition and prolong its life. Follow these cleaning procedures on a timely basis and your grill will stay clean and operate with minimum effort.

**CAUTION:** Be sure your grill is OFF and cool before cleaning.

### Cleaning The Cooking Grids

- Before initial use, and periodically, wash your Cooking Grids in a mild soap and warm water solution. You can use a wash cloth or vegetable brush to clean your Cooking Grids.

### Cleaning The Grease Tray and Receptacle

- To reduce the chance of fire, the Grease Draining Tray and Grease Receptacle (some models) should be visually inspected before each grill use. Remove any grease and wash Grease Tray and Receptacle with a mild soap and warm water solution.

### Cleaning the Inside of the Grill Lid

- Grease can have a tendency to build up on the inside of the Grill Lid and could drip onto deck or patio when the lid is opened. Visually inspect the inside of the Grill Lid before each grill use. Remove any grease and wash with a mild soap and warm water solution.

### Regular Cleaning of The Grill Interior

- Burning-off excess food after every cookout will keep it ready for instant use. However, at least every 3 months you must give the entire grill a thorough cleaning to minimize your risk of grease fire and keep the grill in top shape. Follow these steps:
  1. Turn all Burner Knobs to the full OFF position.
  2. Turn the LP gas tank valve to the full OFF position.
  3. Disconnect the regulator from the gas tank. Inspect the hose with regulator assembly for cracking, cuts or any other damage, and replace as necessary. Refer to the Parts List in this Operator's Manual.
  4. Remove and clean the Cooking Grids, Cooking Rack.
  5. Brush the inside and bottom of the grill with a fiber pad or nylon brush and wash with a mild soap and warm water solution. Rinse thoroughly and let dry.
  6. Check each Spark Electrode, adjusting as needed. The space between the Spark Electrode Tip and Spark Receiver should be approximately 3/16".
  7. Replace Cooking Grids.
  8. Reconnect the gas source and observe the Burner flame for correct operation.



### Cleaning Exterior Surfaces:

Before initial use, and periodically thereafter, we suggest you wash your grill using a mild soap and warm water solution. You can use a wash cloth or sponge for this process. Do not use a stiff wire or brass brush. These will scratch stainless steel and chip painted surfaces (varies by model) during the cleaning process.

### Cleaning Exterior Stainless Steel Surfaces:

Weathering and extreme heat can cause exterior stainless steel surfaces to turn tan in color. Machine oils used in the manufacturing process of stainless steel can also cause this tanning color. After removing any protective PVC film from the Grill Lid and Control Panel use a Stainless Steel Cleaner to polish the stainless steel surfaces of your grill. Never use abrasive cleaners or scrubbers because they will scratch and damage your grill. Follow these steps for the best results.

1. Turn the LP Gas tank valve (clockwise) to the full OFF position. Disconnect the regulator and hose assembly from LP Gas tank.
2. Remove dirt or grease using a soft cloth and polish stainless surfaces. Wipe with a soft cloth.
3. Remove aluminum foil from exposed gas fitting and allow grill to air dry before attaching the regulator and hose to your LP Gas tank.

 **CAUTION** 

**Failure to comply with these instructions may result in a hazardous situation which, if not avoided, may result in injury.**

Keep grill area clear and free from combustible materials, gasoline and other flammable vapors and liquids.

Do not obstruct the flow of air for combustion and ventilation.

Keep the ventilation openings of the tank enclosure cabinet free and clear of debris.

Visually check burner flames occasionally to ensure proper flame pattern as shown below.

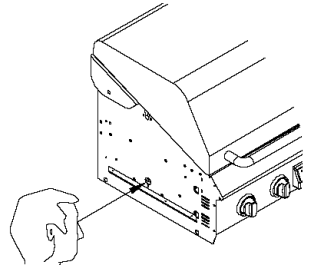

# Infrared Grill Cooking Instructions

## Burn-Off

- Before cooking on your gas grill for the first time, you should "burn off" the grill to eliminate any odor or foreign matter. Ignite the burners, lower the Lid, and operate grill on HIGH setting for 3 to 5 minutes.

**CAUTION:** Infrared cooking times will be much shorter than traditional grilling so never operate this appliance unattended.

## Preheating

- To preheat, light your grill on HIGH, lower the Lid and follow this timetable.
  - For searing and high temperature cooking, preheat grill 3 to 5 minutes.
  - For low temperature cooking, preheat grill 3 minutes.
  - To slow cook, preheating is not necessary.

## Cooking Temperatures

- High setting:** The HIGH Control Knob setting should only be used to pre-heat your grill the first 3-5 minutes, for searing foods and for burning food residue off the grill for 3-5 minutes after cooking is complete.

**CAUTION:** Infrared cooking times will be much shorter than traditional grilling so never operate this appliance unattended.

- Low setting:** Most recipes specify the low setting for baking, roasting, rotisserie cooking and grilling delicate foods such as fish, vegetables and bread.

## An Important Note About Infrared Heat Settings

- The suggested heat settings and cooking times shown in the following pages are approximate. Unlike the controlled environment inside your kitchen, variables including outside temperatures, direction and conditions of wind, as well as grill location will affect your grill's heat distribution. Because these conditions vary, and no two backyards are alike, we offer this guide as a convenience. We recommend you monitor your grill closely and rotate foods often to prevent overcooking and ensure the most delicious results every time.
  - The heat from the front and rear infrared burners overlaps in the mid section of each cooking grid. This area offers the most intense heat for quickly locking in the natural juices and flavor of poultry and meats.
  - The Secondary Cooking Rack offers less intense heat for preparing breads and firm vegetables like potatoes and corn.
  - Infrared heat sears the food surface and cooks from the inside out. Infrared heat does not cook through aluminum foil and reflective pans. For roasting and baking you'll find a cast-iron pan works beautifully as it absorbs and conducts the infrared heat very well.

## Direct Cooking

- The direct cooking method can be used with the supplied Cooking Grids and food placed on the mid section of each cooking grid where the infrared heat is most intense. **Direct Cooking requires the Grill Lid to be open.** This method is ideal for searing and grilling as well as deep frying in a cast-iron pan or stir-frying in a steel wok.

## Indirect Cooking

- To cook **indirectly**, the food should be placed on the left or right side of your grill (or Secondary Rack) with the Burners lit on the opposite side. Rotate the food as needed to ensure even browning. This is the slow cooking method. A faster indirect method is to place your food in an optional cast-iron cooking pan and place it in the center of the grill with all burners on LOW. Be sure to add liquid if using a pan to keep food moist. If higher heat is desired, turn Left Front (LF) and Right Rear (RR) burners on HIGH with Left Rear (LR) and Right Front (RF) burners on LOW to create a crossray cooking pattern. Either way, **indirect cooking must be done with the Lid down.**

## Prepare Cooking Grids for Grilling

- Greasing the cooking surface will help keep foods from sticking during the cookout, produces beautiful sear marks and reduces the amount of cleanup required. Use a brush to apply a thin layer of cooking oil or vegetable shortening onto each Cooking Grid before each cookout. We do not suggest spray type oils unless they are specified for high-temperature cooking.

## To Reduce Flare-Ups and Smoke

- Fat and juice dripping from grilled food can cause flare-ups and smoke. To minimize this, cook your food in the mid section of each cooking grid so drippings fall through the center of the grill into the Grease/Water Tray below.



- Failure to comply with these instructions could result in a fire or explosion that could cause serious bodily injury, death or property damage.
- **Never** line the bottom of the grill housing with aluminum foil, sand or any substance that will restrict the flow of grease into Grease/Water Tray.
- **Before each use of your grill:** Pull out the Grease/Water Tray and remove all grease and food debris to prevent grease fire hazard. It is important to keep this Tray filled with water while grilling to get the best possible results. Wear a flame retardant BBQ Mitt when handling the Grease/Water Tray.
- **Use your grill at least 5 feet away from any wall or surface.** Use your grill at least **5 feet away** from combustible objects that can melt or catch fire (such as vinyl or wood siding, fences and overhangs) or sources of ignition including pilot lights on water heaters and live electrical appliances.
- **Never** use your gas grill in a garage, porch, shed, breezeway or any other enclosed area.
- **Your grill will get very hot.** Always wear a flame retardant BBQ Mitt when cooking on your grill and handling the Grease/Water Tray. Never lean over cooking areas while using grill. Do not touch cooking surfaces, Lid, grill housing or other parts while grill is in operation, or until the grill has cooled down after use. Be aware that the Tray does contain water and grease and be extremely careful when removing to prevent spillage.

# Guide to Infrared Grilling using the Direct Cooking Method

## Grilling Steak and Ribs

**Fill Water Tray half-full.** Turn the grill Burners on HIGH, close the Lid and preheat your grill 3 to 5 minutes. Open Lid and place food on the mid section of a Cooking Grid. Sear 2-3 minutes on each side then adjust the Infrared Burners to LOW and continue cooking until desired doneness. You can also move the seared meat to the Secondary Cooking Rack to finish cooking. This method allows you to sear and prepare larger amounts of meat and keep cooked food warm. Grilling times will vary according to meat thickness.

## Grilling Hamburgers, Brats and Sausages

**Fill Water Tray half-full.** Turn the grill Burners on HIGH, close Lid and preheat your grill 3 to 5 minutes. Open Lid and place food on the mid section of a Cooking Grid. Sear 2-3 minutes on each side then adjust the Infrared Burners to LOW and continue cooking until desired doneness. Grilling times will vary according to meat thickness.

## Grilling Poultry

**Fill Water Tray half-full.** Turn the grill Burners on HIGH, close Lid and preheat your grill 2 to 3 minutes. Open Lid and place food on the mid section of a Cooking Grid. Sear 2-3 minutes on each side then adjust the Infrared Burners to LOW and continue cooking until desired doneness.

To minimize flare-ups, use skinless poultry or use the indirect method. Place the poultry on one side of the grill with the opposing Burners on LOW heat, and lower the grill Lid.

## Grilling Pork

**Fill Water Tray half-full.** Turn the grill Burners on HIGH, close Lid and preheat your grill 3 to 5 minutes. Open Lid and place food on the mid section of a Cooking Grid. Sear 2-3 minutes on each side then adjust the Infrared Burners to LOW and continue cooking until desired doneness. Grilling times will vary according to meat thickness.

## Whole Fish and Whole Fillets

**Fill Water Tray half-full.** Turn the grill Burners on HIGH, close Lid and preheat your grill 3 to 5 minutes. Open Lid and place food (skin down) on the mid section of a Cooking Grid. Sear 2 minutes on each side then adjust the Infrared Burners to LOW and continue cooking until fish is opaque but still moist.

## Vegetables and Fruit

**Fill Water Tray half-full.** Prepare your fruit or vegetables and brush with butter or basting sauce if desired. In some instances, you may want to grill vegetables and fruit **directly** over the heat, using the supplied Cooking Grids. Foods that work best with direct heat are relatively soft and require a short cooking time: mushrooms, zucchini, tomatoes and skewered fruit such as apricots, peaches, pineapple, strawberries and kiwis. Remember the **Grill Lid must remain up when cooking directly.**

To cook **indirectly**, the food should be placed on the left or right side of your grill (or Secondary Rack) with the Burners lit on the opposite side. Either way, **indirect cooking must be done with the Lid down.**

## Cut of Meat

T-bone steak  
Sirloin steak  
Beef spare ribs  
Porterhouse steak  
New York strip steak

Hamburgers  
Brats  
Sausages

Chicken breast  
(cook with bone down)  
Chicken wings  
Drumsticks

Whole bird  
(cook with breast up)

Chops  
Loins  
Cutlets

Whole fish  
Whole fish fillets

## Approx. Total Cooking Times

**Rare:** 4-6 minutes  
**Medium:** 6-8 minutes  
**Well done:** 8-10 minutes

**Rare:** 3-4 minutes  
**Medium:** 5-6 minutes  
**Well done:** 6-8 minutes

**Direct method:**  
approximately 6-8 minutes

**Indirect method:**  
up to 30 minutes

**Indirect method:**  
approximately 1 hour

**Medium:** 10-12 minutes  
**Well done:** 12-14 minutes

Approx. 8 - 18 minutes or  
until fish is opaque

For very firm vegetables—particularly potatoes and yams, we recommend that you partially boil until almost cooked, before placing them on the grill.

**CAUTION:** Infrared cooking times will be much shorter than traditional grilling so never operate this appliance unattended.

**NOTE:** Do not use aluminum foil to wrap vegetables and fruit. Infrared heat does not cook through aluminum foil and reflective pans.

# Guide to Roasting & Baking using the Indirect Cooking Method

## An Important Note About Infrared Heat Settings

The suggested heat settings and cooking times shown are approximate. Unlike the controlled environment inside your kitchen, variables including outside temperatures, direction and conditions of wind, as well as grill location will affect your grill's heat distribution. Because these conditions vary, and no two backyards are alike, we offer this guide as a convenience. We recommend you monitor your grill closely and rotate foods often to prevent over-cooking and ensure the most delicious results every time.

## Preparing to Roast

Roasting uses the **indirect cooking** method. Therefore, the food should be placed on the left or right side of your grill with the Burners lit on the opposite side. You can also use an optional cast-iron pan underneath food allowing you to collect juices for making gravies. Remember, indirect cooking requires the Lid of your grill to be down.

**Fill Water Tray half-full.** Preheating your grill is not required for slow cooking methods such as roasting. If you do choose to preheat your grill before roasting, turn the Burners on HIGH and close Lid for approximately 2 minutes.

## Food preparation

Trim meat of excess fat. Truss meat and poultry with cooking string to retain shape if desired. Bacon strips can be used to cover the outside surface of lean meat and poultry to help prevent it from drying out. To keep food moist during roasting be sure to keep the Water Tray filled. If using an optional cast-iron pan for cooking, you should also add liquid to prevent burning the bottom of your food.

## Tips for roasting

Except when roasting with water in a roasting pan, the juices that collect in the pan can be used as the base for a tasty sauce or gravy. Place a cooking pan directly over the heat, add extra butter if needed, then add several spoonfuls of flour to thicken sauce. Finally, add sufficient chicken or beef stock to obtain the desired consistency.

Once the meat is cooked, remove it from your grill and cover with a piece of foil. Allow it to stand for 10-15 minutes which allows the juices to settle. This will make carving easier and ensure a tender, juicy roast.

Type of Food	How Cooked	Approximate Cooking Times
Beef	Rare	14 minutes per pound
	Medium	18 minutes per pound
	Well done	20 minutes per pound
Lamb	Medium	14 minutes per pound
	Well done	18 minutes per pound
Veal		22 minutes per pound
Pork		23-26 minutes per pound
Chicken		17-20 minutes per pound
Duck		20 minutes per pound
Fish		8 minutes per pound
Turkey, under 16 pounds		17-20 per pound + 20 minutes
Turkey, over 16 pounds		14-18 per pound + 10 minutes

## BAKING TECHNIQUES

### Preparing to Bake

To bake in your new grill you'll need a baking dish or cast-iron cooking pan, and a pair of flame retardant BBQ Mitts. If the cooking pan is cast-iron be sure to season the pan before use.

**Fill Water Tray half-full.** Preheat your grill 3 minutes, then lower heat as needed. Baking uses the **indirect cooking** method. To cook **indirectly**, the food should be placed on the left or right side of your grill with the Burners lit on the opposite side. This is the slow cooking method. A faster indirect method is to place your food in an optional cast-iron cooking pan and place it in the center of the grill with

all burners on LOW. If higher heat is desired, turn Left Front (LF) and Right Rear (RR) burners on HIGH with Left Rear (LR) and Right Front (RF) burners on LOW to create a crossray cooking pattern. Either way, **indirect cooking must be done with the Lid down.**

### Tips for Baking

Prepare your favorite recipe as you would in the kitchen. You will need to stir the food several times as it bakes, and add additional liquid as required. Watch the temperature, and adjust to cook according to your recipe directions.

### Oven Temperature

Slow	300° - 340° F
Moderate	355° - 390° F
High	410° - 480° F

### Recommended Grill Setting

Left or right 2 burners on LOW
All 4 burners on LOW
LF + RR burners on HIGH and LR + RF burners on LOW

## Infrared Rotisserie Cooking

### Balancing the Food

In rotisserie cooking, balancing the food is of utmost importance. The rotisserie must turn evenly or the stopping and starting action will cause the food to cook unevenly and possibly burn the heavier side.

The easiest foods to balance are those of uniform shape and texture. To test if the food is balanced correctly when secured, place the ends of the rotisserie spit loosely in the palms of your hands. If there is no tendency to roll, give the spit a quarter turn. If it is still stable, give it a final quarter turn. It should rest without turning in each of these positions. It can then be attached to your grill.

### Food Preparation

When preparing poultry, truss the birds tightly so that wings and drumsticks are close to the body of the bird. The cavity of the bird may be stuffed prior to this. Pull the neck skin down and, using a small skewer, fix it to the back of the bird. Push the rotisserie spit through lengthwise, catching the bird in the fork of the wishbone. Center the bird and tighten with the holding forks. Test the balance as described before.

A rolled piece of meat requires the rotisserie skewer to be inserted through the center of the length of meat, then secured and balanced. For meats that contain bones, it is best to secure the rotisserie skewer diagonally through the meaty sections.

### Slow Cooking with a Rotisserie

Your Kenmore 16671 with bi-lateral infrared burners is the ideal set-up for Rotisserie cooking because of the unique position and angle of the infrared burners. Rotisserie cooking produces foods that are moist, flavorful and attractive. The optional Rotisserie Kit is most commonly used for cooking meat or poultry and is designed to cook food slowly. You can place a cooking pan beneath the food to collect juices for basting and gravy.

After your food is balanced on the Rotisserie Spit and attached to your grill, **fill Water Tray half-full** and turn the Rotisserie motor on. Observe the rotation to be sure the Rotisserie is turning evenly, then turn the front and rear Burners on LOW. Infrared rotisserie cooking on LOW heat can be done with the Lid open or closed.

**CAUTION:** DO NOT rotisserie cook with all burners on high and the Lid closed. The intense infrared heat will overcook your food and can damage your grill. Never operate this appliance unattended.

## Guide to Smoking

### Preparing to Smoke

Smoking gives food a distinctive, delicious flavor. You will find a variety of wood chips available for use in smoking grilled foods. Pre-soaking of wood chips may be required so read and follow the manufacturer's instructions for preparing smoking chips prior to use.

**Note:** It is our experience that many smoking chip products do not actually produce a smoke but instead infuses the food with flavor. Please read product labels carefully and if in doubt, ask your retailer for details.

### Using A Cast-Iron Smoker Box

There are many optional smoker boxes available for purchase but cast-iron is the type recommended for use with your infrared grill. Follow these guidelines and always refer to the label of your smoking chips for specific directions.

**Fill Water Tray half-full.** Turn the left or right grill Burners on HIGH, close Lid and preheat your grill 3 to 5 minutes. Fill your smoker box with your prepared smoking chips. Wear a flame retardant BBQ Mitt and place your smoker box about 6 inches from the back of a Cooking Grid directly above a lit grill Burner. Allow smoker chips to heat about 30 minutes (or until the scent of smoke is evident) then turn Burners to LOW and add your food.

To cook **indirectly**, the food should be placed on the left or right side of your grill (or Secondary Rack) opposite the lit burners and smoker box. **When cooking with a smoker box the Lid must be down.**

### Tips for Smoking

You can reduce the strength of the smoke flavor by only smoking for half or three quarters of the cooking time.

Foods naturally high in oils lend themselves well to smoking, while drier foods benefit from a marinade.

- **Tuna steaks**, marinated in Asian flavors of sesame oil, soy sauce and sherry.
- **Pork filets**, rubbed with ginger, orange rind and brushed with maple syrup.
- **Mussels**, brushed with lemon rind and chili oil.
- **Lamb cutlets**, marinated in virgin olive oil, lemon, oregano and black pepper. The same marinade can be used for a whole leg or rack of lamb.
- **Chicken**, boneless chicken pieces—especially sliced breasts.
- **Fish**, sliced filets of firm fish, assorted seafood such as prawns, scallops and calamari.
- **Pork**, sliced filets, diced or minced pork, sliced leg steak, sliced chops.
- **Beef**, sliced fillet, rib-eye, round, rump, sirloin.
- **Lamb**, sliced fillet, round, loin.



## Guide to Stir-Frying and Deep-Frying

### STIR-FRYING TECHNIQUES

This method of cooking is popular around the world and can be easily accomplished outdoors on your gas grill. It's a quick and healthful way of preparing a complete meal using meat, poultry or seafood in infinite combinations with other interesting ingredients like vegetables, rice or noodles.

#### Preparing to Stir-fry

Although it is possible to stir fry in other dishes, a wok is your best tool. Its high sides enable the cook to stir food without spillage. Its construction allows you to cook quickly at high temperatures, with instant control of heat which is essential for successful stir frying.

#### Food preparation

Slice meat and poultry into long thin strips and cube fish fillets. Remove all fat from meat and poultry and cut large vegetables into even slices or cubes.

Marinate foods for extra flavor and tenderness. Marinating times will vary for red meat, fish and or various cuts. Less tender cuts of meat should be marinated longer. Remember to always chill marinating food in the refrigerator prior to cooking.

Stir-fry meats, poultry or fish first. Next, add hard vegetables like carrots. Then continue with softer vegetables like snowpeas and peppers. To ensure even cooking, continually stir and toss the food in the wok using a wooden spoon or spatula.

#### Tips for Stir-frying

Place a wok on a Cooking Grid or Side Burner directly over a HIGH heat . Add only a small amount of food at a time to ensure fast cooking and also to allow the wok to reheat between ingredients.

### DEEP-FRYING TECHNIQUES

A wide variety of foods can be deep-fried outdoors on your grill, from potatoes, to seafood and chicken. Deep-frying uses a large portion of oil, preferably saturated. The outdoor location is ideal for deep-frying as smoke, grease and smells disperse in the open air instead of collecting on the ceiling of your kitchen.

#### Preparing to Deep-fry

Deep-fry on your grill using an optional cast-iron pan over direct heat.

Fill a cooking pan no more than half full of vegetable or corn oil. **Fill Water Tray half-full.** Turn the grill Burners on HIGH, close Lid and preheat your grill 3 to 5 minutes. Open Lid and place cast-iron pan on the mid section of a Cooking Grid then adjust the Infrared Burners to LOW.

Check the temperature of the oil carefully with a frying thermometer or test with a cube of bread. The cube of bread should brown in about 30 seconds for most cooking needs. A temperature between 350 and 400 degrees is optimal for preparing the majority of deep-fried foods.

#### Food Preparation

Foods being deep-fried taste better when coated with either batter or breadcrumbs to add flavor and prevent moisture from escaping.

#### Tips for Deep-frying

Wear a flame retardant BBQ Mitt and slowly lower foods into the hot oil using a wire scoop, fry-basket or stainless steel tongs. Add only a small quantity of food to the oil, allow it to cook, then repeat with another small quantity. This ensures the oil doesn't drop in temperature. Once the food is cooked, remove it carefully and drain onto a paper towel. Turn the heat off as soon as you have finished deep-frying and allow your pan to cool. When the oil is cool, remove all remnants of fried foods by straining it through a fine metal sieve, and store it in a clean bottle for future use.

## Guide to Using the Secondary Cooking Rack

Vegetables are generally easy to cook on the grill. The Cooking Rack makes it convenient because you can still use the main cooking area while the vegetables are suspended above the grids.

Pre-cook hard vegetables by briefly boiling or microwaving them before cooking on the grill. Do not grill your vegetables wrapped in aluminum foil. Infrared heat does not cook through aluminum foil and reflective pans. To keep vegetables moist, brush them with butter or oil often.

The Cooking Rack can be used for purposes other than just the obvious. Consider using the rack for warming French bread, garlic bread, croissants or even bagels.

## Don't Forget Your Grill Accessories

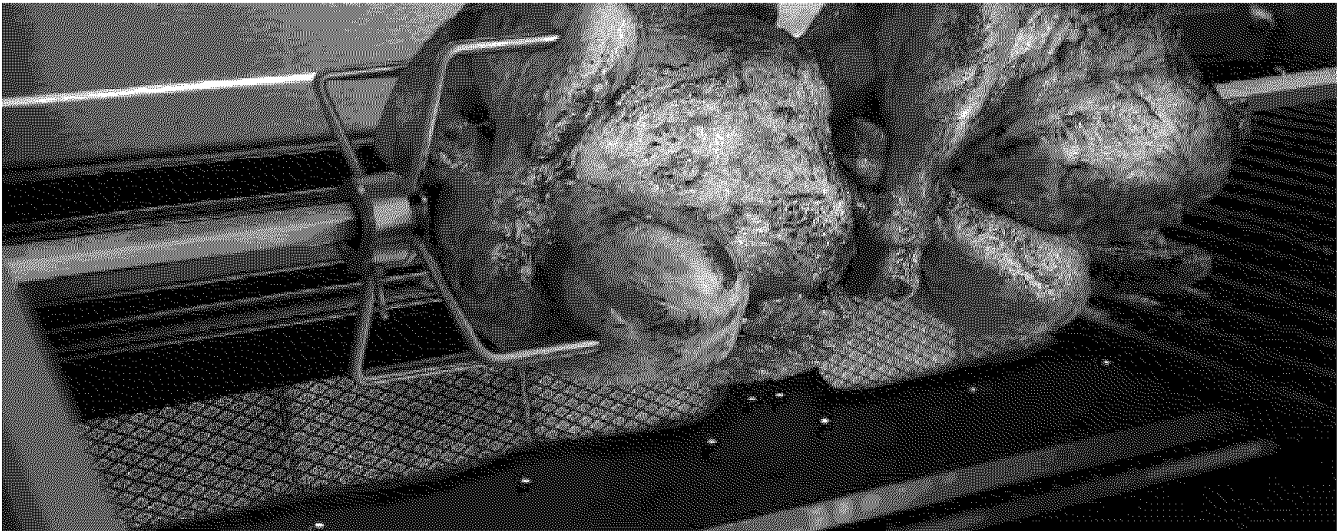

**Anything you enjoy cooking indoors can be prepared outdoors as well.** These optional grill accessories make it easy to enjoy your new Kenmore Premium or Kenmore Elite grill as an outdoor kitchen.

Not all locations carry all items and availability is limited to supplies on hand. Accessory fit will vary by grill model so ask a sales associate for details.

Grill accessories are offered at most larger Sears full line stores, Sears Grand, Sears Hardware, The Great Indoors, Orchard Supply Hardware and sears.com.

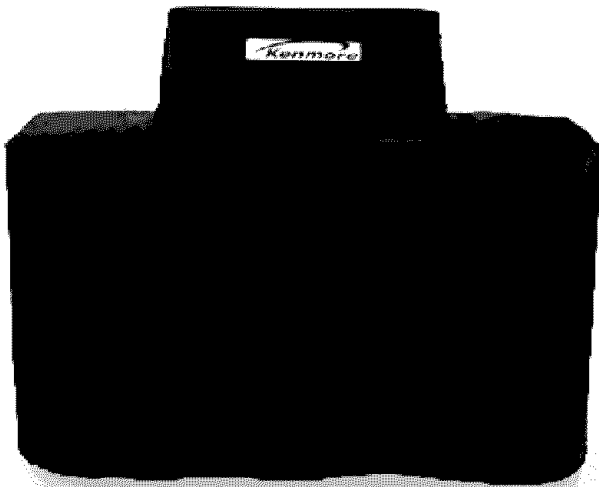

Protect your grill from rain, snow and seasonal debris with a quality made grill cover. Fit varies by grill model.

Your Kenmore 16671 with bi-lateral infrared burners is the ideal set-up for Rotisserie cooking because of the unique position and angle of the infrared burners. Rotisserie cooking produces foods that are moist, flavorful and attractive. The optional Rotisserie Kit is most commonly used for cooking meat or poultry and is designed to cook food slowly.

To learn more about the preparation and technique of infrared Rotisserie cooking refer to page A-4 of this Operator's Manual.

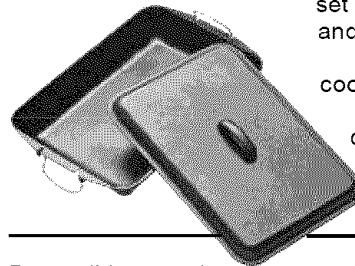

This cast-iron Pan and Lid set conducts heat beautifully and is versatile for use in all cooking methods; direct cooking, indirect baking and roasting, stir-frying and deep frying. Also great for catching juices when Rotisserie cooking.

Reversible cast-iron Griddle offers a flat side for grilling breakfast, fish and fajitas and a ribbed side for cooking bacon, sausages and burgers.

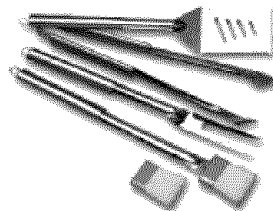
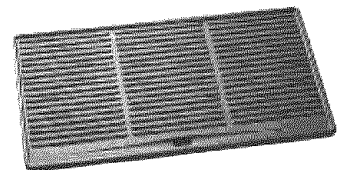

Quality 304 grade stainless steel grill tools offer long reach handles for easier outdoor cooking.

**Call the Grill Information Center** if you have any problem with this product. We can help with questions about assembly, grill operation, accessory availability or if there are damaged or missing parts when you unpack this unit from the shipping box. Please call us before contacting your local retailer.

### GRILL INFORMATION CENTER

Call 8am to 8pm CST **1-888-317-7642** Monday through Friday

**Question:**

**Can I convert my grill from one fuel type to another in other words from LPG to NG or vice versa?**

**Answer:**

No, your gas grill is manufactured to exact specifications and is certified for LPG (Liquid Propane Gas) or NG (Natural Gas) use only. For your safety, conversion kits are not available, nor will we sell or otherwise provide parts or information to be used to convert your grill. Any attempt to convert your grill is dangerous and will void your warranty.

**Question:**

**Are the serial and model numbers of my grill listed somewhere for reference?**

**Answer:**

The serial and model numbers are listed on a silver CSA label placed on the grill. Depending on the grill model, the silver CSA label will be located on the left or right side bowl panel underneath the side shelf, underneath the right side of the control panel, outside left or right of control panel or on the back of the grill cabinet.

**Question:**

**My grill will not light properly. Why?**

**Answer:**

Try this procedure:

1. Turn gas off at source and turn Control Knobs OFF. Wait at least 5 minutes for gas to clear, then retry.
2. If your grill still fails to light, turn the Burner Control Knob(s) and gas source OFF and conduct a leak test of ALL gas connections and gas sources as explained in the Use and Care section of this manual.
3. If no leaks are detected, wait 5 minutes for any gas to clear and repeat the lighting procedure.

**Question:**

**If my ignitor or battery is not working how can I light my grill manually? And - Why would I need the silver lighting stick that hangs from the side of my grill?**

**Answer:**

If your ignition fails to work or your battery needs replacing, you can light your grill through the Lighting Hole on the side of the grill bowl using the Manual Lighting Stick that hangs from the side of your grill. The Lighting Stick is designed to hold a paper match and allows you to safely insert a match through the Lighting Hole without getting close to the Burner. Never remove the Cooking Grids and attempt to light the grill from above. To light your gas grill manually, insert a paper match into the Manual Lighting Stick and follow steps 1 through 6 of the Basic Lighting Procedures. Then, light the match and place it through the Lighting Hole on the left side of the grill (location of hole varies by grill model). Turn the nearest main Burner Control Knob to the High setting to release gas. The Burner should light immediately.

**Question:**

**Sometimes I hear a humming sound coming from my regulator. What causes this? And - My grill has a low flame and sometimes will not light. Why?**

**Answer:**

The humming sound is gas flowing through the regulator. A low volume of sound is normal and will not interfere with the operation of your grill. Loud or excessive regulator humming and/or low flow and intermittent lighting may be caused by the regulator's excess gas flow device. Opening the tank valve all the way or too quickly is what triggers the regulator's safety device to restrict gas flow, preventing excess gas flow to your grill. Lighting the main Burner farthest from the fuel source every time will help eliminate air pockets in the manifold. Note: This procedure should be done every time a new LP Gas tank is connected to your grill.

- Turn all Control Knobs to the OFF position.
- Turn off the LP Gas tank at the tank valve.
- Disconnect regulator from LP Gas tank.
- Let unit stand for 5 minutes.
- Reconnect regulator to the LP Gas tank.
- Open grill Lid (or Side Burner Lid if you are lighting the Side Burner)
- Turn the tank valve slowly ¼ of one turn.
- Light the left main Burner.
- Turn the tank valve slowly one more ¼ of one turn for ½ of one complete turn.
- Turn Knob for each other burner and light as you move toward the fuel source.
- Do not turn tank valve more than ½ of one turn.

**Question:**

**Where do I use my grill for safer operation and better performance?**

**Answer:**

- Strong winds and low temperatures can affect the heating and performance of your gas grill so factor in these elements when positioning your grill outdoors for cooking.
- Use your grill at least 5 feet away from any wall or surface.
- Use your grill at least **5 feet away** from combustible objects that can melt or catch fire (such as vinyl or wood siding, fences and overhangs) or sources of ignition including pilot lights on water heaters and live electrical appliances.
- Never** use your gas grill in a garage, porch, shed, breezeway or any other enclosed area.
- Never** obstruct the flow of ventilation air around your gas grill housing.

**Question:**

**The Regulator and Hose supplied with my gas grill does not fit the older LP Gas tank I've used for years. Why not?**

**Answer:**

The U.S. Government regulates gas appliances and LP Gas tanks. When regulations are changed the LP Gas tank fittings are altered to insure compliance. If your LP Gas tank does not fit the Regulator and Hose supplied with your new grill, the tank is outdated and must be replaced. Note: Effective April 1, 2002 all LP Gas tanks sold must include an "OPD" Overfill Prevention Device. The OPD tanks are identified by their triangular-shaped valve wheel. This internal device prevents the LP Gas tank from being overfilled. Tanks without an OPD valve can not be refilled.

**Question:**

**Is it safe to clean my porcelain coated cooking grids in the dishwasher?**

**Answer:**

Clean your cooking grids by hand if there are any chips or cracks in the porcelain finish and dry them thoroughly. If no chips or cracks are present it should be safe to use the dishwasher. Remember to dry the cooking grids thoroughly before placing back onto your grill to minimize rusting.

**Question:**

**What causes grill parts to rust and what affect does it have on my grill?**

**Answer:**

Rusting is a natural oxidation process and may appear on cast-iron and steel parts. Rust will not affect the short term performance of your grill.

To slow the rusting process on steel Cooking Grids (select models) we recommend greasing the Cooking Grids before and after each cookout. Use a brush to apply a thin layer of cooking oil or vegetable shortening onto each Cooking Grid. We do not suggest spray type oils unless they are specified for high-temperature cooking. Be sure to coat the entire cooking surface including edges and any areas with chipped porcelain.

**Question:**

**Which is a better cooking surface to grill on; porcelain coated steel / cast-iron cooking grids or stainless steel grids?**

**Answer:**

They all have their advantages. For traditional grilling and searing meats, cast-iron or steel grids offer better heat conductivity. To protect against the natural rusting process, steel or cast-iron cooking grids offer a porcelain finish which requires routine maintenance to keep the grids well seasoned.

Stainless steel is popular with those who prefer less maintenance.

A new innovative solution is available on select models called Stainless Clad Therma-Core®. This Cooking Grid combines a heat conducting steel core with an easy-to-clean stainless outer shell.

# Master Protection Agreements

*Congratulations on making a smart purchase.* Your new Kenmore® product is designed and manufactured for years of dependable operation. But like all products, it may require preventive maintenance or repair from time to time. That's when having a Master Protection Agreement can save you money and aggravation.

The Master Protection Agreement also helps extend the life of your new product. Here's what the Agreement\* includes:

- **Parts and labor** needed to help keep products operating properly **under normal use**, not just defects. Our coverage goes **well beyond the product warranty**. No deductibles, no functional failure excluded from coverage - **real protection**.
- **Expert service** by a force of more than **10,000 authorized Sears service technicians**, which means someone you can trust will be working on your product.
- **Unlimited service calls and nationwide service**, as often as you want us, whenever you want us.
- **"No-lemon" guarantee** – replacement of your covered product if four or more product failures occur within twelve months.
- **Product replacement** if your covered product can't be fixed.
- **Annual Preventive Maintenance Check** at your request – no extra charge.
- **Fast help by phone** – we call it **Rapid Resolution** – phone support from a Sears representative on all products. Think of us as a "talking owner's manual."
- **Power surge protection** against electrical damage due to power fluctuations.
- **\$250 Food Loss Protection** annually for any food spoilage that is the result of mechanical failure of any covered refrigerator or freezer. •
- **Rental reimbursement** if repair of your covered product takes longer than promised.
- **10% discount** off the regular price of any non-covered repair service and related installed parts.

Once you purchase the Agreement, a simple phone call is all that it takes for you to schedule service. You can call anytime day or night, or schedule a service appointment online.

The Master Protection Agreement is a risk free purchase. If you cancel for any reason during the product warranty period, we will provide a full refund. Or, a prorated refund anytime after the product warranty period expires. Purchase your Master Protection Agreement today!

**Some limitations and exclusions apply. For prices and additional information in the U.S.A. call 1-800-827-6655.**

**\* Coverage in Canada varies on some items. For full details call Sears Canada at 1-800-361-6665.**

## **Sears Installation Service**

*For Sears professional installation* of home appliances, garage door openers, water heaters, and other major home items, in the U.S.A. or Canada call **1-800-4-MY-HOME®**.

# Get it fixed, at your home or ours!

## Your Home

For repair – **in your home** – of **all** major brand appliances, lawn and garden equipment, or heating and cooling systems, **no matter who made it, no matter who sold it!**

For the replacement parts, accessories and owner's manuals that you need to do-it-yourself.

For Sears professional installation of home appliances and items like garage door openers and water heaters.

**1-800-4-MY-HOME®** (1-800-469-4663)

Call anytime, day or night (U.S.A. and Canada)

[www.sears.com](http://www.sears.com)    [www.sears.ca](http://www.sears.ca)

For expert home solutions advice: [www.managemyhome.com](http://www.managemyhome.com)

---

## Our Home

For repair of carry-in items like vacuums, lawn equipment, and electronics, call or go on-line for the location of your nearest

**Sears Parts & Repair Service Center**

**1-800-488-1222** (U.S.A.)    **1-800-469-4663** (Canada)

Call anytime, day or night

[www.sears.com](http://www.sears.com)    [www.sears.ca](http://www.sears.ca)

---

To purchase a protection agreement on a product serviced by Sears:

**1-800-827-6655** (U.S.A.)

**1-800-361-6665** (Canada)

---

Para pedir servicio de reparación a domicilio, y para ordenar piezas:

**1-888-SU-HOGAR®**

(1-888-784-6427)

Au Canada pour service en français:

**1-800-LE-FOYER<sup>MC</sup>**

(1-800-533-6937)

[www.sears.ca](http://www.sears.ca)

