

Char-Broil®

MODEL 415.16103 • 640-106145-113 • PRODUCT GUIDE



THIS GRILL IS FOR OUTDOOR USE ONLY.

⚠ CAUTION:

Read and follow all safety statements, assembly instructions, and use and care directions before attempting to assemble and cook.

INSTALLER/ASSEMBLER:

Leave this manual with consumer.

CONSUMER:

Keep this manual for future reference.

⚠ WARNING:

Failure to follow all manufacturer's instructions could result in serious personal injury and/or property damage.

⚠ CAUTION:

Some parts may contain sharp edges – especially as noted in the manual! Wear protective gloves if necessary.

If you have any questions or need assistance during assembly, please call 1-800-241-7548.

To insure your satisfaction and for follow-up service, register your grill online at www.grillregistration.com

 **DANGER** 

If you smell gas:

1. Shut off gas to the appliance.
2. Extinguish any open flame.
3. Open lid.
4. If odor continues, keep away from the appliance and immediately call your gas supplier or your fire department.

 **WARNING** 

1. Do not store or use gasoline or other flammable liquids or vapors in the vicinity of this or any other appliance.
2. An LP cylinder not connected for use shall not be stored in the vicinity of this or any other appliance.

Call Grill Service Center for Help and Parts

- If you need assistance with your product or warranty parts call **1-800-241-7548. Hours of Service Center Operation are 8:00 A.M. To 6:00 P.M. EST Monday - Friday.**
- To order non-warranty replacement parts or accessories please visit us on the web at www.charbroil.com or call 1-800-241-7548 and one of our friendly and knowledgeable agents will be glad to assist you.

IMPORTANT: Fill out the product record information below.

Model Number _____

Serial Number _____
See rating label on grill for serial number.

Date Purchased _____

 **CAUTION** 

For residential use only. Do not use for commercial cooking.

Installation Safety Precautions

- Use grill only with LP (propane) gas and the regulator/valve assembly supplied.
- Grill installation must conform with local codes, or in their absence with **National Fuel Gas Code, NFPA 54 / ANSI Z223.1** and **Natural Gas and Propane Installation Code, CSA B149.1**. Handling and storage of LP cylinders must conform to LP Gas Code **NFPA/ANSI 58**. Grill is not for use in or on recreational vehicles and/or boats.
- All electrical accessories (such as rotisserie) must be electrically grounded in accordance with local codes, or **National Electrical Code, ANSI / NFPA 70**. Keep any electrical cords and/or fuel supply hoses away from any hot surfaces.
- This grill is safety certified for use in the United States only. Do not modify for use in any other location. Modification will result in a safety hazard.

 **WARNING** 

CALIFORNIA PROPOSITION 65

Combustion by-products produced when using this product contain chemicals known to the State of California to cause cancer, birth defects, and other reproductive harm.

Safety Symbols

The symbols and boxes shown below explain what each heading means. Read and follow all of the messages found throughout the manual.

 **DANGER** 

DANGER: Indicates an imminently hazardous situation which, if not avoided, will result in death or serious injury.

 **WARNING** 

WARNING: Indicates an potentially hazardous situation which, if not avoided, could result in death or serious injury.

 **CAUTION** 

CAUTION: Indicates a potentially hazardous situation or unsafe practice which, if not avoided, may result in minor or moderate injury.

TABLE OF CONTENTS

For Your Safety	2
Grill Service Center.	2
Product Record Information	2
Installation Safety Precautions	2
Safety Symbols	2
Use and Care	4-10
Parts List	11
Parts Diagram	12
Assembly	13-23
Troubleshooting	24-25
Limited Warranty	26
Registration Card	27

**To insure your satisfaction
and for follow-up service,
register your grill
online at:
www.grillregistration.com**

	WARNING	
<p>Do not attempt to repair or alter the hose/valve/regulator for any “assumed” defect. Any modification to this assembly will void your warranty and create the risk of a gas leak and fire. Use only authorized replacement parts supplied by manufacturer.</p>		

Certified Grill Parts And Accessories®, Char-Broil and Design®, Char-Broil (Gas Grill Briquettes)®, Char-Diamonds®, Cooking Zone and Design®, Diamond Flame®, Executive Chef®, Faststart®, Flare Fighter®, FlavorMaster®, Gas Grill Silhouette and Design®, H2O Smoker®, Lava Flame®, MasterFlame®, MasterFlame Precision Cooking System®, PowerSpark®, Quantum®, VIP®, PrecisionFlame and Design®, Sierra®, and TruFlame® are registered Trademarks of the W.C. Bradley Company. Thermos® is a registered trademark of the Thermos Company and its affiliates.

Artisan Collection by Char-Broil™, C3 and Design™, Char-Broil and Design™, Flame Design™, FlavorTents™, Grill 2 Go™, Grillin' Stick™, Keeper of the Flame™, Keepers of the Flame™, Natural Grip™, Outdoor Cooking Collection and Design™, Patio Bistro™, PrecisionFlame™, Pro-Check™, QuickSet Grills and Design™, SmokerTents™, The Big Easy™, The Minute Grill™, The Edge™, The Tuscan Collection™, and The Urban Grill™ are Trademarks of the W.C. Bradley Company. Universal Grill Parts and Design™ is a trademark of the Thermos Company and its affiliates.

Protected under one or more of the following U.S. Patents: 4,598,692; 4,624,240; 4,747,391; 4,747,391; 4,817,583; 4,924,846; 4,989,579; 5,003,960; 5,076,256; 5,076,257; 5,090,398; 5,109,834; 5,224,676; 5,277,106; 5,421,319; 5,441,226; 5,452,707; 5,458,309; 5,566,606; 5,566,606; 5,579,755; 5,582,094; 5,613,486; 5,649,475; 5,706,797; 5,711,663; 5,765,543; 5,931,149; 5,996,573; 6,095,132; 6,135,104; 6,173,644B1; 6,279,566; 6,397,731; 6,418,923; 6,439,222; 6,523,461; 6,935,327; D282,619; D339,714; D341,292; D343,337; D358,059; D361,466; D364,535; D372,637; D373,701; D377,735; D383,035; D397,910; D405,643; D405,643; D406,005; D406,009; D413,043; D413,229; D413,229; D414,982; D415,388; D416,164; D416,441; D416,441; D417,587; D422,516; D423,274; D423,876; D428,303; D435,396; D436,004; D438,059; D438,060; D438,427; D439,110; D442,505; D443,179; D443,354; D447,384; D447,385; D447,909; D448,610; D448,614; D448,615; D448,616; D448,975; D449,492; D451,759; D456,202S; D460,313, D461,359 and D504,048. Canada: 87743; 87744; 92607; 92608 and 1,316,424. Other Patents Pending. Assembly instructions © 2006.

USE AND CARE



DANGER



- **NEVER** store a spare LP tank under or near grill or in enclosed areas



- Never fill the cylinder beyond 80% full.
- An overfilled or improperly stored tank is a hazard due to possible gas release from the safety relief valve.
- If you see, smell or hear escaping gas, immediately get away from the LP tank/grill and call your fire department.
- If the above is not followed exactly, a fire causing death or serious injury may occur.

LP Tank Removal, Transport And Storage

- Turn OFF all control knobs and LP tank valve. Turn coupling nut counterclockwise by hand only - do not use tools to disconnect. Lift LP tank wire upward off of LP tank collar, then lift LP tank up and off of support bracket. Install safety cap onto LP tank valve. Always use cap and strap supplied with valve. **Failure to use safety cap as directed may result in serious personal injury and/or property damage.**

LP Tank Valve

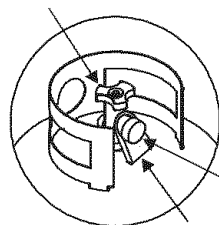

Safety Cap

Retainer Strap

- A disconnected LP tank in storage or being transported must have a safety cap installed (as shown). Do not store an LP tank in enclosed spaces such as a carport, garage, porch, covered patio or other building. Never leave an LP tank inside a vehicle which may become overheated by the sun.
- Do not store an LP tank in an area where children play.

LP Tank

- The LP tank used with your grill must meet the following requirements:
- Use LP tanks only with these required measurements: 12" (30.5cm) (diameter) x 18" (45.7 cm) (tall) with 20 lb. (9 kg.) capacity maximum.
- LP tanks must be constructed and marked in accordance with specifications for LP tank of the U.S. Department of Transportation (DOT). See LP tank collar for marking.
- LP tank valve must have:
 - Type 1 outlet compatible with regulator or grill.
 - Safety relief valve.
 - UL listed Overfill Protection Device (OPD). This OPD safety feature is identified by a unique triangular hand wheel. **Use only LP tanks equipped with this type of valve.**
- LP tank must be arranged for vapor withdrawal and include collar to protect LP tank valve.

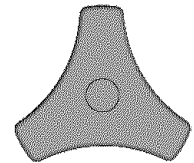

OPD Hand Wheel

LP (Liquefied Petroleum Gas)

- LP gas is nontoxic, odorless and colorless when produced. **For Your Safety**, LP gas has been given an odor (similar to rotten cabbage) so that it can be smelled.
- LP gas is highly flammable and may ignite unexpectedly when mixed with air.

LP Tank Filling

- Use only licensed and experienced dealers.
- LP dealer **must purge tank** before filling.
- Dealer should **NEVER** fill LP tank more than 80% of LP tank volume. Volume of propane in tank will vary by temperature.
- A frosty regulator indicates gas overfill. Immediately close LP tank valve and call local LP gas dealer for assistance.
- Do not release liquid propane (LP) gas into the atmosphere. This is a hazardous practice.
- To remove gas from LP tank, contact an LP dealer or call a local fire department for assistance. Check the telephone directory under "Gas Companies" for nearest certified LP dealers.

LP Tank Exchange

- Many retailers that sell grills offer you the option of replacing your empty LP tank through an exchange service. Use only those reputable exchange companies that inspect, precision fill, test and certify their cylinders. **Exchange your tank only for an OPD safety feature-equipped tank as described in the "LP Tank" section of this manual.**
- Always keep new and exchanged LP tanks in upright position during use, transit or storage.
- **Leak test new and exchanged LP tanks BEFORE connecting to grill.**

LP Tank Leak Test

For your safety

- Leak test must be repeated each time LP tank is exchanged or refilled.
- Do not smoke during leak test.
- Do not use an open flame to check for gas leaks.
- Grill must be leak tested outdoors in a well-ventilated area, away from ignition sources such as gas fired or electrical appliances. During leak test, keep grill away from open flames or sparks.
- Use a clean paintbrush and a 50/50 mild soap and water solution. Brush soapy solution onto areas indicated by arrows in figure below. Leaks are indicated by growing bubbles.

	WARNING	
If "growing" bubbles appear do not use or move the LP tank. Contact an LP gas supplier or your fire department!		

- ▲ **Do not use household cleaning agents.** Damage to gas train components can result.

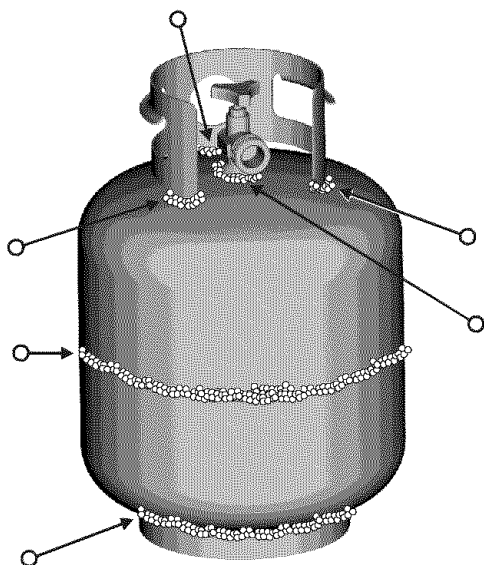

Connecting Regulator To The LP Tank

1. LP tank must be properly secured onto grill. (Refer to assembly section.)
2. Turn all control knobs to the OFF position.
3. Turn LP tank OFF by turning OPD hand wheel clockwise to a full stop.
4. Remove the protective cap from LP tank valve. Always use cap and strap supplied with valve.

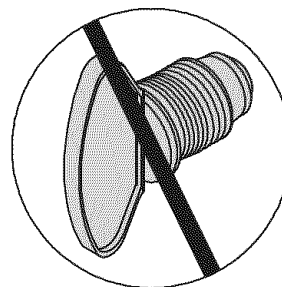
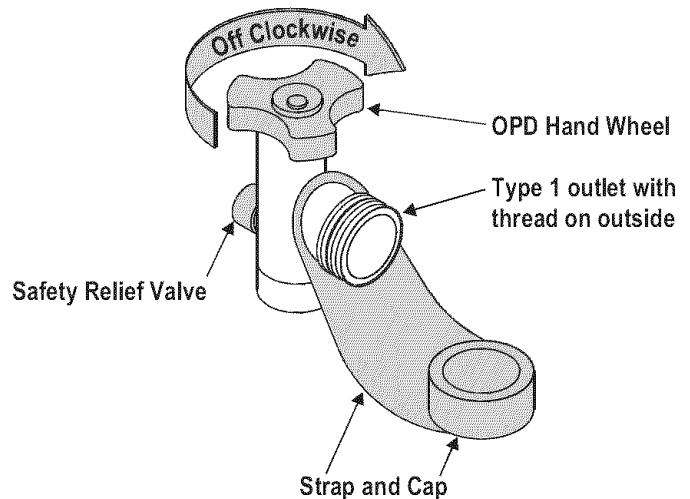

Do not use a POL transport plug (plastic part with external threads)! It will defeat the safety feature of the valve.

5. Hold regulator and insert nipple into LP tank valve. Hand-tighten the coupling nut, holding regulator in a straight line with LP tank valve so as not to cross-thread the connection.

Nipple has to be centered into the LP tank valve.

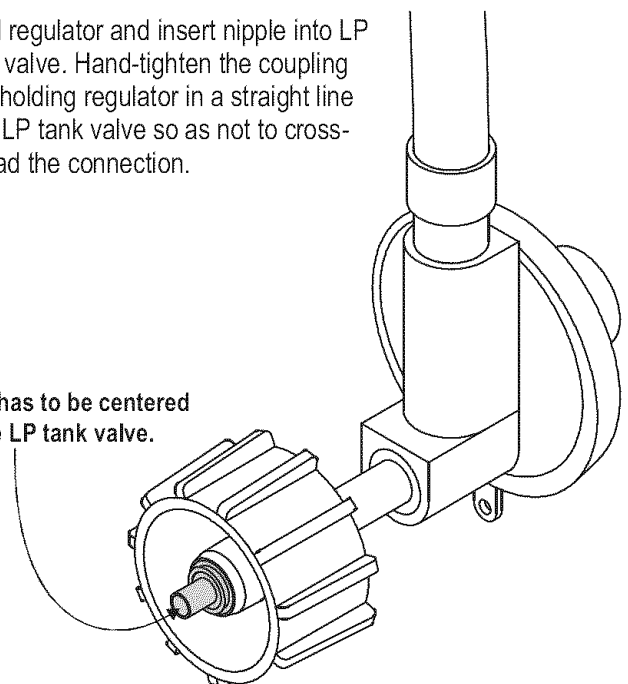

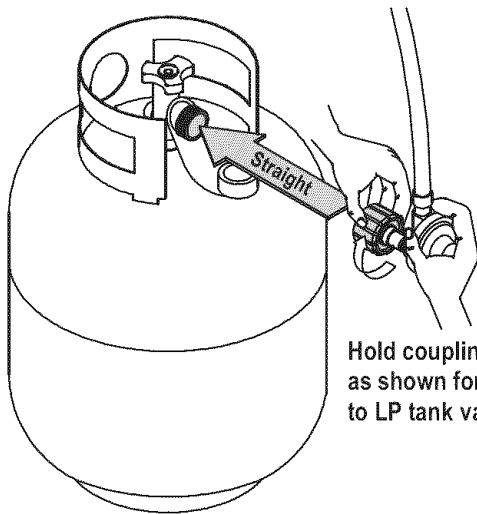

Hold coupling nut and regulator as shown for proper connection to LP tank valve.

6. Turn the coupling nut clockwise and tighten to a full stop. The regulator will seal on the back-check feature in the LP tank valve, resulting in some resistance. **An additional one-half to three-quarters turn is required to complete the connection. Tighten by hand only – do not use tools.**

NOTE:

If you cannot complete the connection, disconnect regulator and repeat steps 5 and 6. If you are still unable to complete the connection, **do not use this regulator!**

	DANGER	
<ul style="list-style-type: none"> • Do not insert any tool or foreign objects into the valve outlet or safety relief valve. You may damage the valve and cause a leak. Leaking propane may result in explosion, fire, severe personal injury, or death.. • If a leak is detected at any time, STOP and call the fire department. • If you cannot stop a gas leak, <i>immediately</i> close LP tank valve and call LP gas supplier or your fire department! 		

	WARNING	
<ul style="list-style-type: none"> • Never attempt to attach this grill to the self-contained LP gas system of a camper trailer or motor home. • Do not use grill until leak-tested. 		

Leak Testing Valves, Hose and Regulator

1. Turn all grill control knobs to OFF.
2. Be sure regulator is tightly connected to LP tank.
3. Completely open LP tank valve by turning OPD hand wheel counterclockwise. If you hear a *rushing sound*, turn gas off immediately. There is a major leak at the connection. **Correct before proceeding.**
4. Brush soapy solution onto areas where bubbles are shown in picture below:

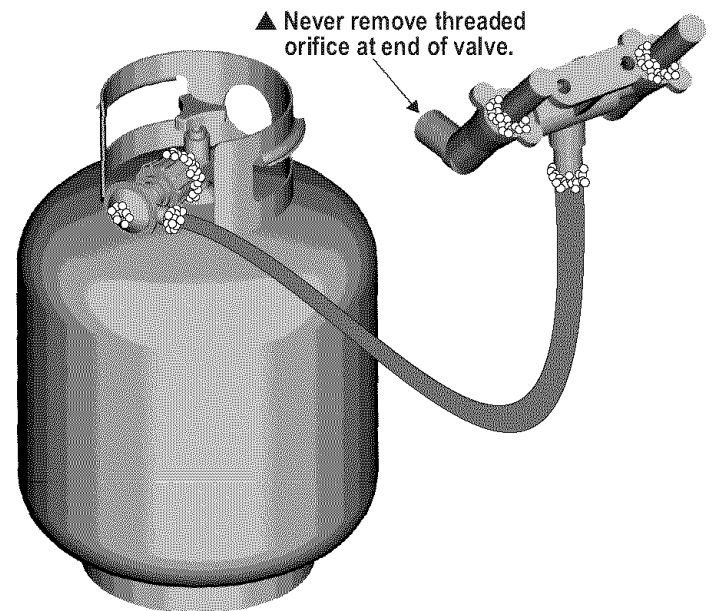

5. If “growing” bubbles appear, there is a leak. Close LP tank valve immediately and re-tighten connections. **If leaks cannot be stopped do not try to repair.** Call for replacement parts. Order new parts by giving the serial, model number, name and part number of items needed (see parts list) to the Grill Service Center at 1-800-241-7548.
6. Always close LP tank valve after performing leak test by turning hand wheel clockwise.



WARNING



For Safe Use Of Your Grill And To Avoid Serious Injury:

- Do not let children operate or play near grill.
- Keep grill area clear and free from materials that burn.
- Do not block holes in bottom or back of grill.
- Check burner flames regularly.
- Use grill only in well-ventilated space. NEVER use in enclosed space such as carport, garage, porch, covered patio, or under an overhead structure of any kind.
- Do not use charcoal or ceramic briquets in a gas grill. (Unless briquets are supplied with your grill.)
- **Use grill at least 3 ft. from any wall or surface.** Maintain 10 ft. clearance to objects that can catch fire or sources of ignition such as pilot lights on water heaters, live electrical appliances, etc.

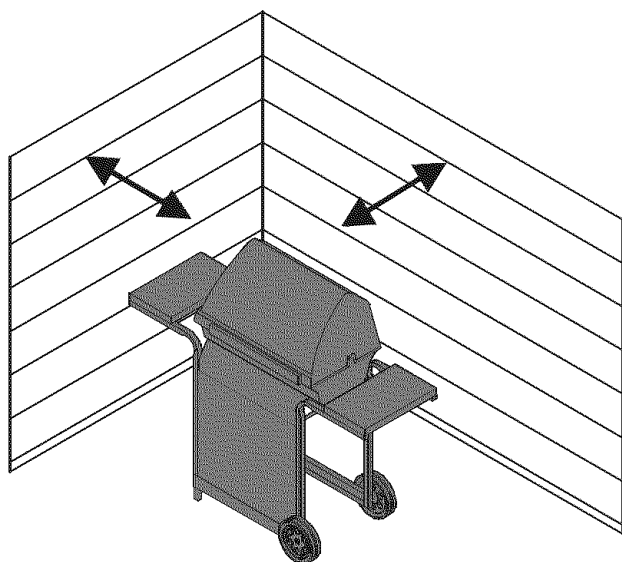

• Apartment Dwellers:

Check with management to learn the requirements and fire codes for using an LP gas grill in your apartment complex. If allowed, use outside on the ground floor with a three (3) foot clearance from walls or rails. Do not use on or under balconies.

- **NEVER attempt to light burner with lid closed. A buildup of non-ignited gas inside a closed grill is hazardous.**
- **Never operate grill with LP tank out of correct position specified in assembly instructions.**
- **Always close LP tank valve and remove coupling nut before moving LP tank from specified operation position.**

Safety Tips

- ▲ Before opening LP tank valve, check the coupling nut for tightness.
- ▲ When grill is not in use, turn off all control knobs and LP tank valve.
- ▲ Never move grill while in operation or still hot.
- ▲ Use long-handled barbecue utensils and oven mitts to avoid burns and splatters.
- ▲ Maximum load for shelves is 10 lbs.
- ▲ Do not use a cooking pot larger than 9" on grid.
- ▲ The grease cup **must** be attached to grease cup clip and emptied after each use. Do not remove grease cup until grill has completely cooled.
- ▲ If you notice grease or other hot material dripping from grill onto valve, hose or regulator, turn off gas supply at once. Determine the cause, correct it, then clean and inspect valve, hose and regulator before continuing. Perform a leak test.
- ▲ The regulator may make a humming or whistling noise during operation. This will not affect safety or use of grill.
- ▲ If you have a grill problem see the "Troubleshooting Section".



WARNING





If the regulator frosts, turn off grill and LP tank valve immediately. This indicates a problem with the tank and it should not be used on any product. Return to supplier!

Ignitor Lighting

▲ Do not lean over grill while lighting.

1. Open lid during lighting.
2. To ignite, turn left knob to 🔥 HIGH.
3. Push IGNITOR button rapidly.
4. If ignition does NOT occur in 5 seconds, turn the burner controls off, wait 5 minutes, and repeat the lighting procedure.
5. Ignite right burner, turn knob to 🔥.
6. If ignitor does not work, wait 5 minutes, then follow match lighting instructions.



	CAUTION	
<p>If burner does not light, turn knobs to OFF, wait 5 minutes, and try again. Always close valve during the 5 minute waiting period. If the burner does not ignite with the valve open, gas will continue to flow out of the burner and could accidentally ignite with risk of injury.</p>		

Match-Lighting

▲ Do not lean over grill while lighting.

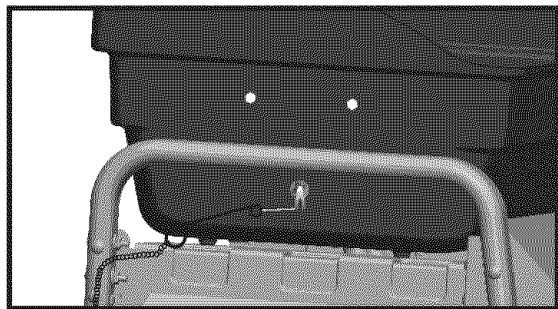
1. Open lid during lighting.
2. Place match into match holder (hanging from side of cart).
3. Push in and turn left knob to 🔥 HIGH position. Be sure burner lights and stays lit.
4. Light right burner by pushing knob in and turning to 🔥 HIGH position.



	CAUTION	
<ul style="list-style-type: none">• Putting out grease fires by closing the lid is not possible. Grills are well ventilated for safety reasons.• Do not use water on a grease fire. Personal injury may result. If a grease fire develops, turn knobs and LP tank off.• Do not leave grill unattended while preheating or burning off food residue on high. If grill has not been regularly cleaned, a grease fire can occur that may damage the product. Follow instructions on General Grill Cleaning and Cleaning The Burner Assembly to prevent grease fires.		

Before Your First Cookout

- Light burners, check to make sure they are lit, close the lid and warm up grill on HIGH for 15 minutes. This curing of paint and parts will produce an odor only on first lighting.

Burner Flame Check

- Light burner, rotate knobs from HIGH to LOW. You should see a smaller flame in LOW position than seen on HIGH. Always check flame prior to each use. If only low flame is seen refer to "Sudden drop or low flame" in the *Troubleshooting Section*.

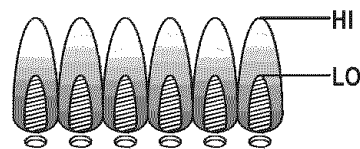

Hose Check

- Before each use, check to see if hoses are cut, worn or kinked. Replace damaged hoses before using grill. Use only valve/hose/regulator specified in the Parts List.

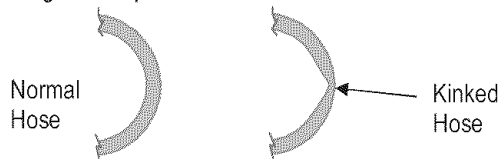

Turning Grill Off

- Turn all knobs to **OFF** position. Turn LP tank off by turning OPD hand wheel clockwise to a full stop.

Ignitor Check

- **Turn gas off at LP tank.** Press and hold ignitor button. "Click" should be heard and spark seen each time between collector box or burner and electrodes. See "Troubleshooting" if no click or spark.

Valve Check

- **Important: Make sure gas is off at LP tank before checking valves.** Knobs lock in **OFF** position. To check valves, first push in knobs and release, knobs should spring back. If knobs do not spring back, replace valve assembly before using grill. Turn knobs to **LO** position then turn back to **OFF** position. Valves should turn smoothly.

General Grill Cleaning

- Keep the outside of your grill looking new by cleaning it once a month with warm soap and water or a non-abrasive cleaner. If you don't have a grill cover, wipe off dust and grime before starting your grill.
- Coating the cooking grids with spray-on cooking oil will keep the food from sticking and make clean up easier. After cooking, scrape the grates with a long handled, brass wire bristle brush.
- Check inside the grill bottom for grease build up and clean often, especially after cooking fatty meat.
- Do not mistake brown or black accumulation of grease and smoke for paint. Apply a strong solution of detergent and water or use a grill cleaner with scrub brush on insides of grill lid and bottom. Rinse and allow to completely air dry. **Do not apply a caustic grill/oven cleaner to painted surfaces.**
- **Plated wire grates:** Wash grates with concentrated grill cleaner or use soap and water solution. Dry thoroughly and store indoors between cookouts.
- **Plastic parts:** Wash with warm soapy water and wipe dry.
 - ▲ Do not use citrisol, abrasive cleaners, degreasers or a concentrated grill cleaner on plastic parts. Damage to and failure of parts can result.
- **Porcelain grates:** Because of glass-like composition, most residue can be wiped away with baking soda/water solution or specially formulated cleaner. Use non-abrasive scouring powder for stubborn stains.



SPIDER ALERT!

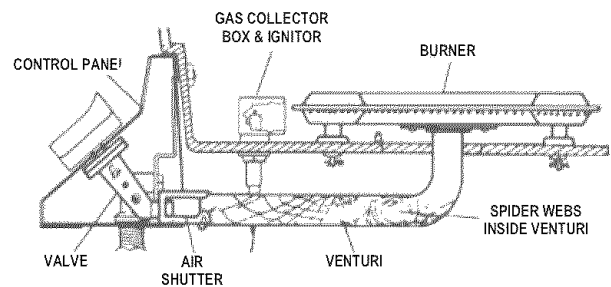

If you notice that your grill is getting hard to light or that the flame isn't as strong as it should be, take the time to check and clean the venturi's.

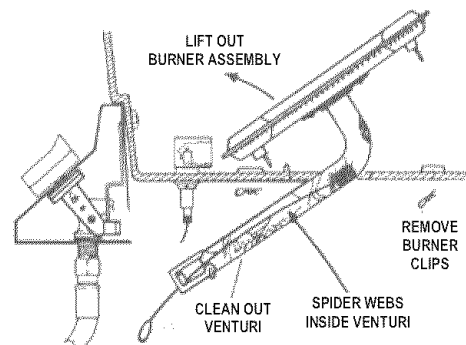

In some areas of the country, spiders or small insects have been known to create "flashback" problems. The spiders spin webs, build nests and lay eggs in the grill's venturi tube(s) obstructing the flow of gas to the burner. The backed-up gas can ignite in the venturi behind the control panel. This is known as a flashback and it can damage your grill and even cause injury.

To prevent flashbacks and ensure good performance the burner and venturi assembly should be removed from the grill and cleaned before use whenever the grill has been idle for an extended period.

Cleaning the Burner Assembly

Follow these instructions to clean and/or replace parts of burner assembly or if you have trouble igniting grill.

1. Turn gas off at control knobs and LP cylinder.
2. Remove cooking grate and heat tent.
3. Under grill remove grease cup, disconnect ignitor wire from burner.
4. Inside grill remove burner assembly (A), clean ceramic portion of electrode with rubbing alcohol and a swab.
5. Clean outside of burner with soap and water. Lay burner upside down on flat surface, insert garden hose to force water through tubes. Make sure water comes out of all burner holes. Open clogged holes with a thin wire. Shake out excess water and examine holes. Due to normal wear and corrosion some holes may become enlarged. If any large cracks or holes are found replace burner.
6. If grill is to be stored, coat burner lightly with cooking oil. Wrap in protective cover to keep insects out.
7. If not storing grill after cleaning, replace burner into grill bottom.

VERY IMPORTANT: Burner tubes must re-engage valve openings. See illustration (A).

8. Reattach ignitor wire to electrode.
9. Reposition heat tent and cooking grate. Reattach clean grease cup to grease clip.
10. Before cooking again on grill, perform a "Leak Test" and "Burner Flame Check".

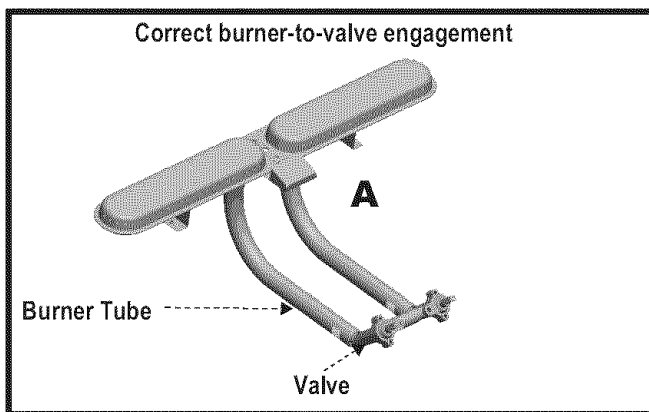

Storing Your Grill

- Clean cooking grates.
- Store in dry location.
- When LP tank is connected to grill, store outdoors in well-ventilated space and out of reach of children.
- Cover grill if stored outdoors.
- Store grill indoors ONLY if LP tank is turned off and disconnected, removed from grill and stored outdoors.
- When removing grill from storage follow "Cleaning Burner Assembly" instructions before starting grill.

Food Safety

Food safety is a very important part of enjoying the outdoor cooking experience. To keep food safe from harmful bacteria, follow these four basic steps:

Clean: Wash hands, utensils, and surfaces with hot soapy water before and after handling raw meat and poultry.

Separate: Separate raw meats and poultry from ready-to-eat foods to avoid cross contamination. Use a clean platter and utensils when removing cooked foods.

Cook: Cook meat and poultry thoroughly to kill bacteria. Use a thermometer to ensure proper internal food temperatures.

Chill: Refrigerate prepared foods and leftovers promptly.

For more information call: USDA Meat and Poultry Hotline at 1-800-535-4555 (In Washington, DC (202) 720-3333, 10:00 am-4:00 pm EST).

How To Tell If Meat Is Grilled Thoroughly

- Meat and poultry cooked on a grill often browns very fast on the outside. Use a meat thermometer to be sure food has reached a safe internal temperature, and cut into food to check for visual signs of doneness.
- Whole poultry should reach 180° F; breasts, 170° F. Juices should run clear and flesh should not be pink.
- Hamburgers made of any ground meat or poultry should reach 160° F, and be brown in the middle with no pink juices. Beef, veal and lamb steaks, roasts and chops can be cooked to 145° F. All cuts of pork should reach 160° F.
- NEVER partially grill meat or poultry and finish cooking later. Cook food completely to destroy harmful bacteria.
- When reheating takeout foods or fully cooked meats like hot dogs, grill to 165° F, or until steaming hot.

PARTS LIST

Key	Qty	Description	Part #
A	1	Firebox	8001006
B	1	Heat Shield	80010068
C	1	Burner Assembly	80010069
D	1	Lid	80010070
E	1	Logo Plate	80010071
F	2	Shelves	80010072
G	2	Mounting Brackets, Right	80010073
H	2	Mounting Brackets, Left	80010074
I	1	Support Bracket	80010075
J	1	Tank Retainer Bracket	80010076
K	1	Leg, Upper Right	80010077
L	2	Leg, Right	80010078
M	2	Leg, Left	80010079
N	1	Leg, Upper Left	80010080
O	2	Back Braces	80010081
P	1	Tank Support Bracket	80010082
Q	1	Firebox Support, Left	80010083
R	1	Firebox Support, Right	80010084
S	1	Tank Exclusion Wire	80009836
T	1	Valve/Hose/Regulator	80010085
U	1	Control Panel	80010086
V	1	Panel	80010087
W	1	Axle Rod	80010088
X	2	Leg Extenders	80009820
Y	1	Grease Cup	80000270
Z	1	Grease Cup Clip	80005794

Key	Qty	Description	Part #
AA	1	Tank Retainer	80010192
BB	1	Ignitor	80008322
CC	2	Wheels	80010191
DD	2	Control Knobs	80009706
EE	2	Hinges, Lower	80010090
FF	2	Hinges, Upper	80010091
GG	1	Handle	80010092
HH	1	Heat Tent	80009840
II	1	Cooking Grate	80009841
JJ	1	Swing Away	80009825
	1	Hardware Pack	80009846
	1	Wheel Bushing	
	2	Hinge Pins	
	3	Hitch Pins	
	1	Wing Screw, #10-24x3/8"	
	1	Screwdriver	
	30	Screws, #10-24x1/2"	
	50	Nuts, #10-24	
	2	Wing Nuts, 1/4"-20	
	20	Screws, #10-24x1-1/4"	
	12	Screws, #10-24x2"	
	2	Lock Washers	
	12	Fiber Washers, 5mm	
	2	Fiber Washers, 7mm	

PARTS DIAGRAM

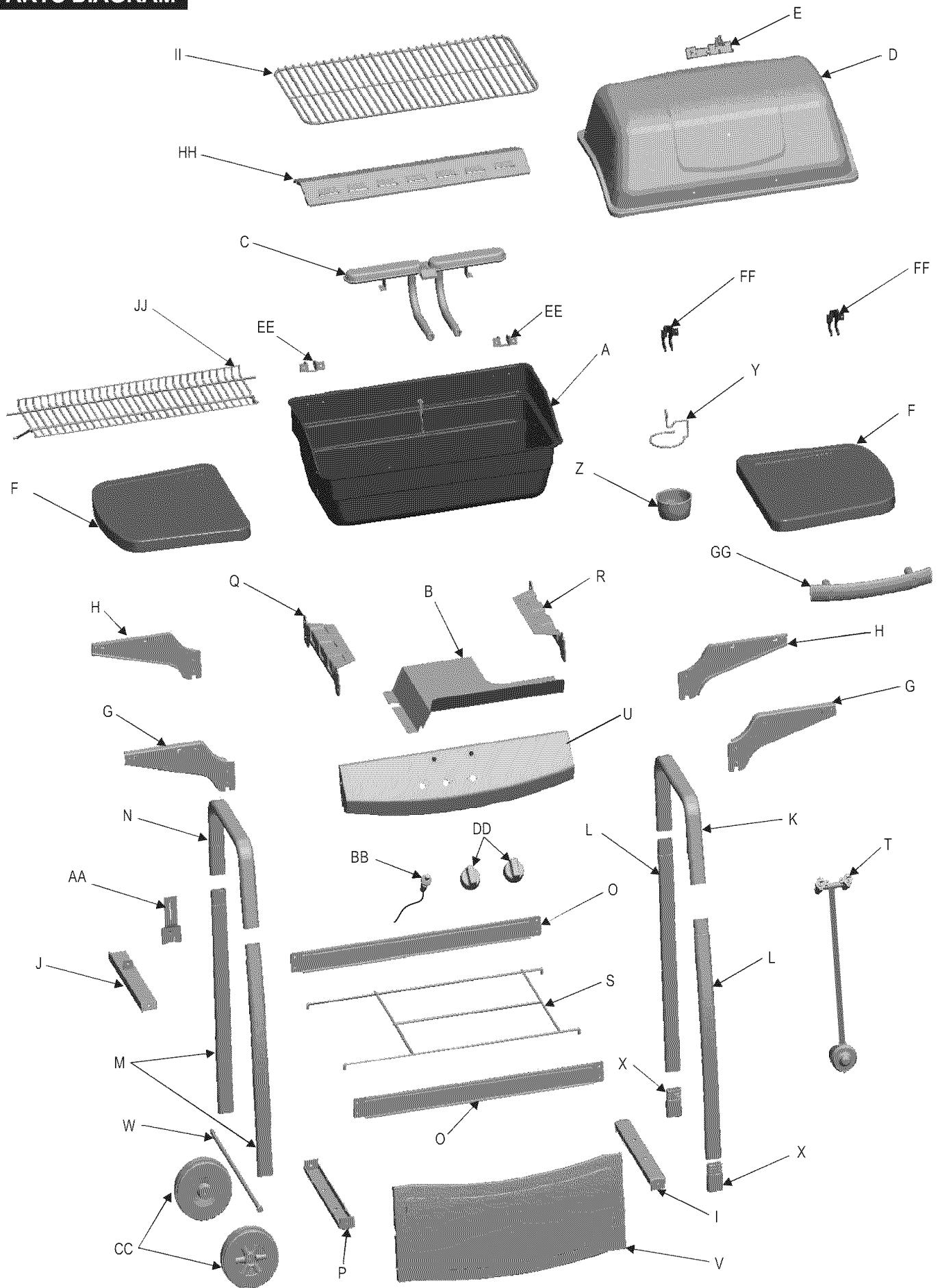

ASSEMBLY

1

Left Leg

- Place left upper leg as shown (A). NOTE: Lower left leg has two large holes at the bottom. In front, attach upper leg, tank retainer bracket side brace and lower leg with #10-24x1-1/4" screw and #10-24 nut (B). In back, place screw #10-24x1-1/4" screw and #10-24 nut. Do not tighten.
- Attach tank support bracket in second hole from bottom of leg with a hinge pins and hitch pins.

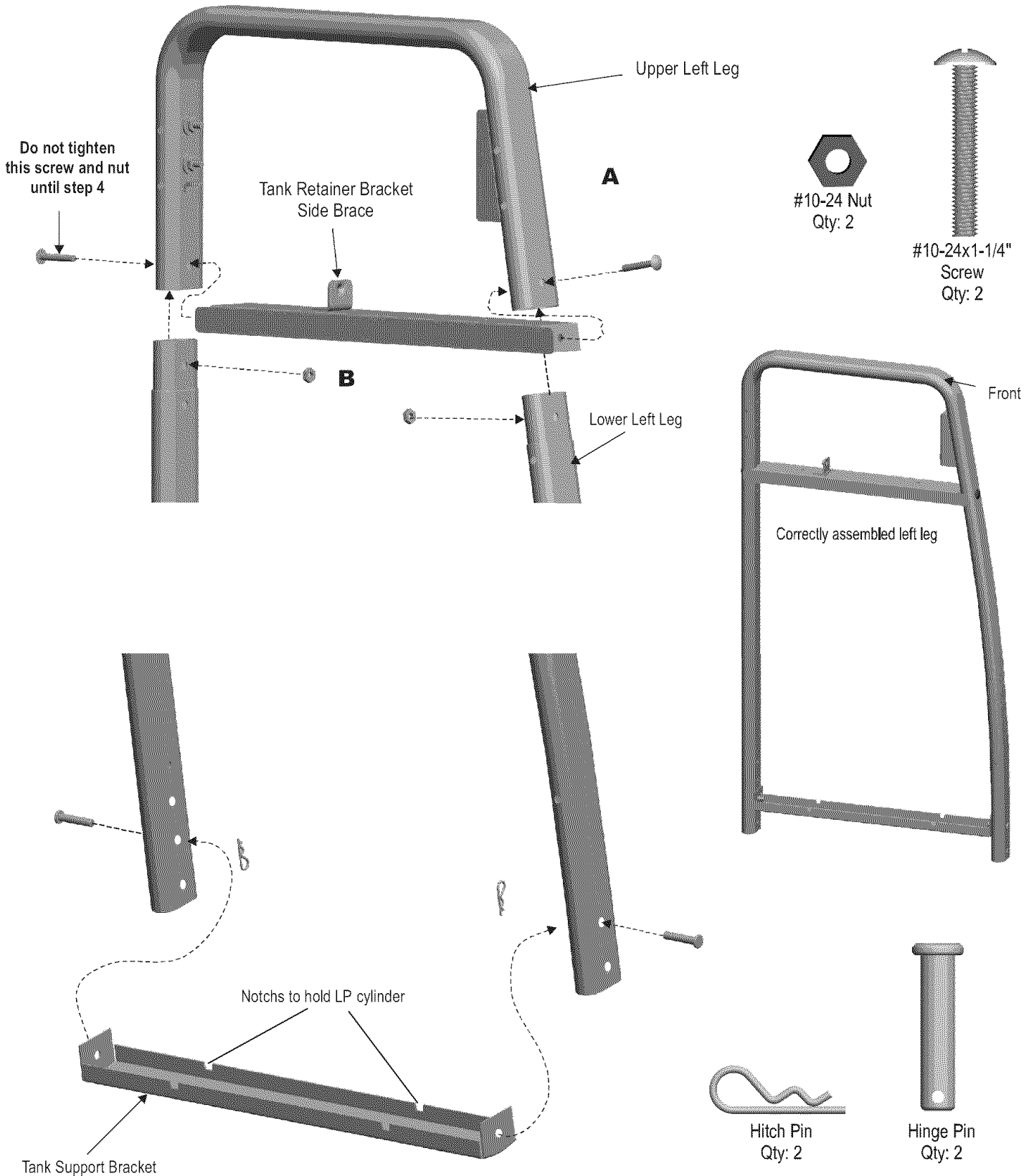

2

Right Leg

- Place right upper leg as shown (A). Attach upper leg and lower leg with #10-24x1-1/4" screws and #10-24 nuts (B).
- Attach support bracket with #10-24x1-1/4" screws and #10-24 nuts.

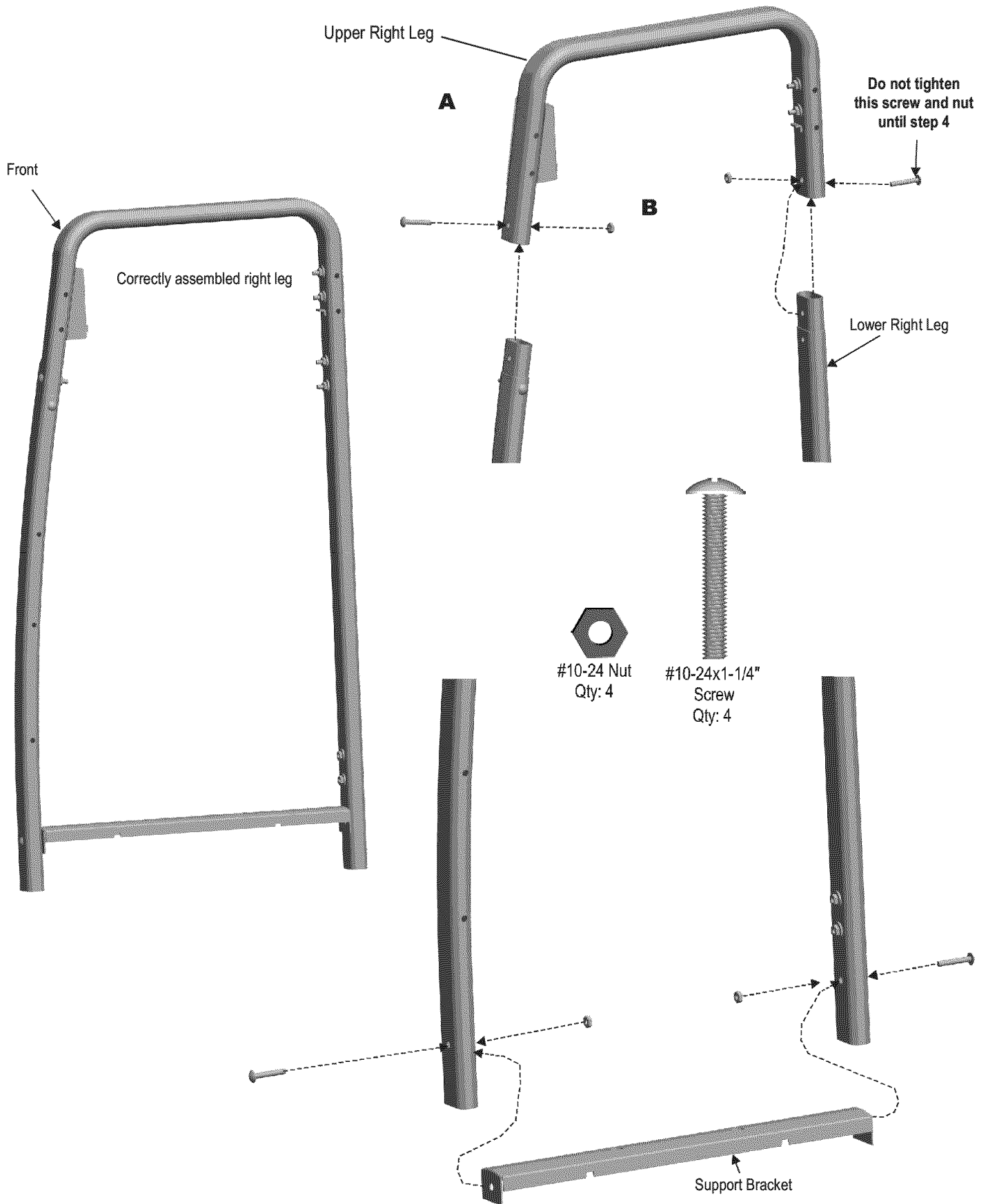

3

Tank Exclusion Wire

- Hook tank exclusion wire into legs with opening for LP cylinder on tank bracket side.

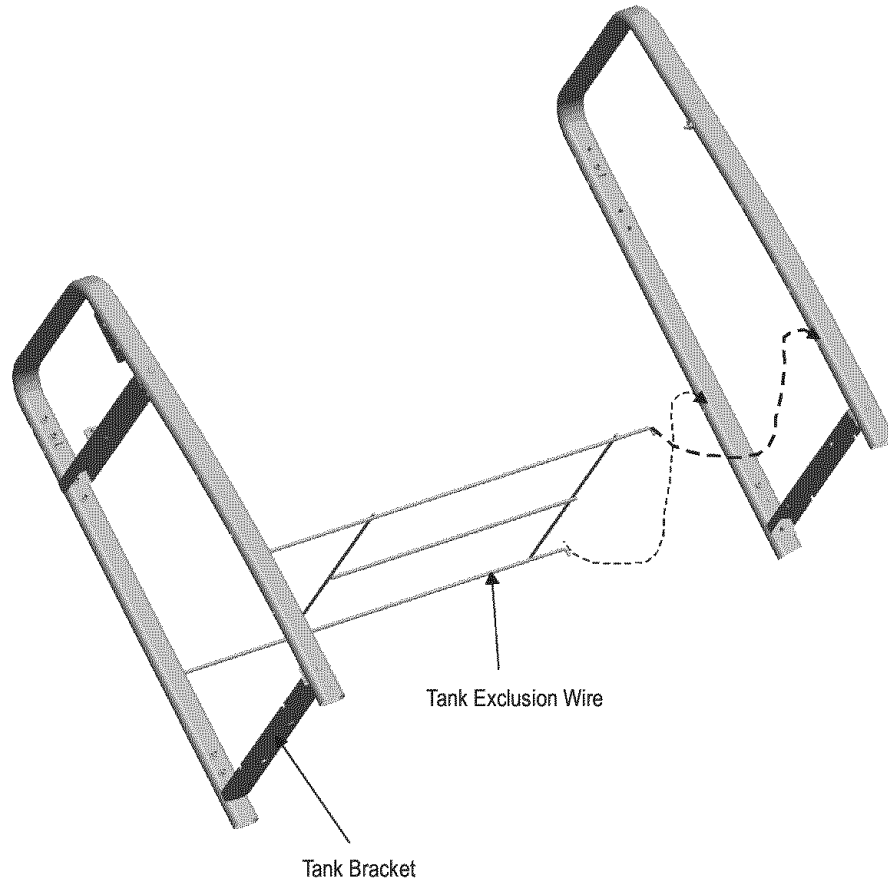

4

Front Panel

Lay front legs down on the floor.

- Slide panel under legs. Attach with #10-24x2" screws and nuts.

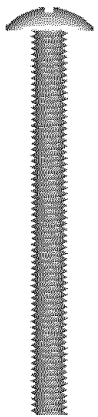

#10-24x2" Screw
Qty: 4



#10-24 Nut
Qty: 4

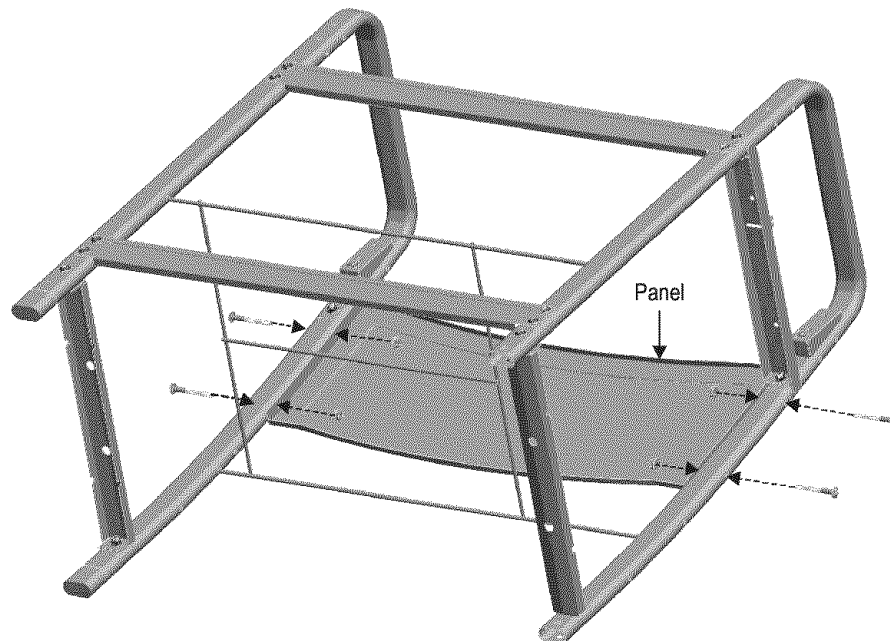

5

Wheels, Leg Extenders and Back Braces to Cart

- Turn assembly upside down.
- On both sides remove screws and nuts from tank retainer and support bracket as shown. Attach back braces with #10-24x1-1/4" screws and nuts.
- Insert axle rod into wheel, legs and other wheel. Attach with a wheel bushing and hitch pin.
- Push leg extenders into right legs.

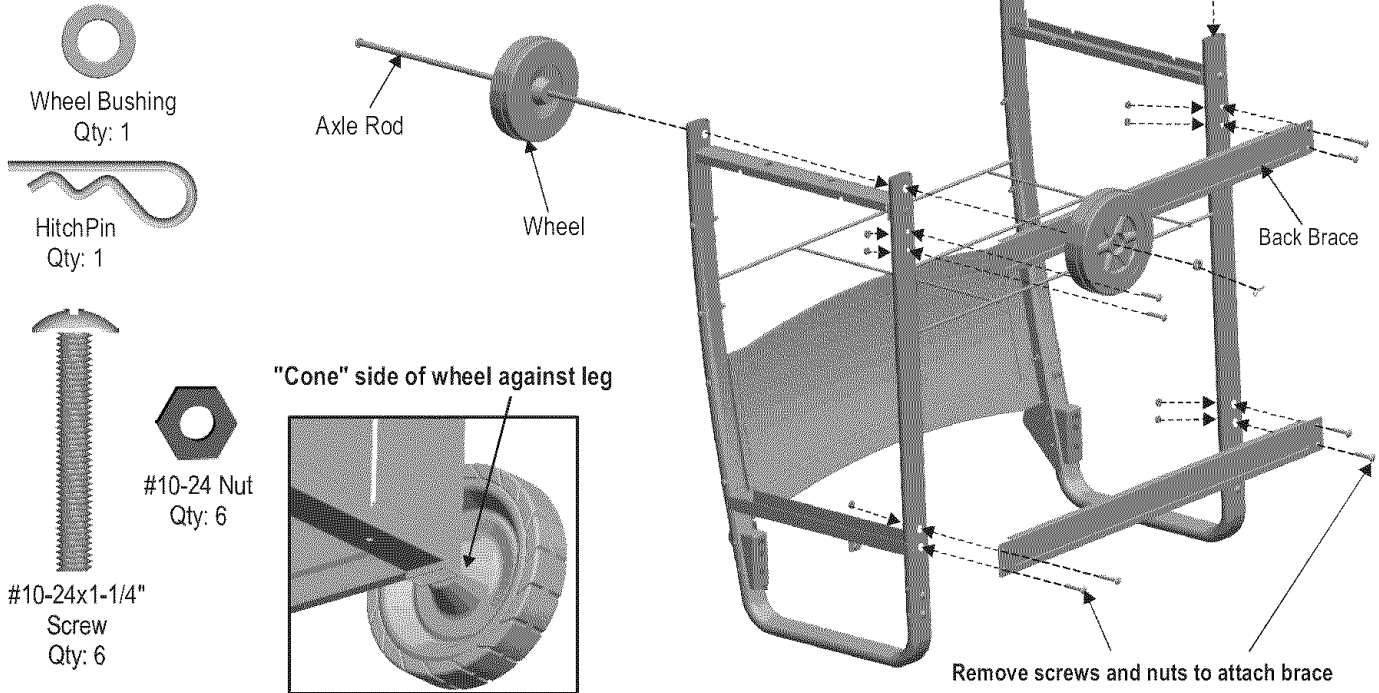

6

Control Panel and Upper Firebox Supports

- Stand cart upright.
- In front, attach control panel with #10-24x2" screws. Place upper firebox supports onto screws and tighten with #10-24 nuts. Tighten all screws.
- In back leg, attach upper firebox support with #10-24x2" screws and #10-24 nuts. Do not tighten.

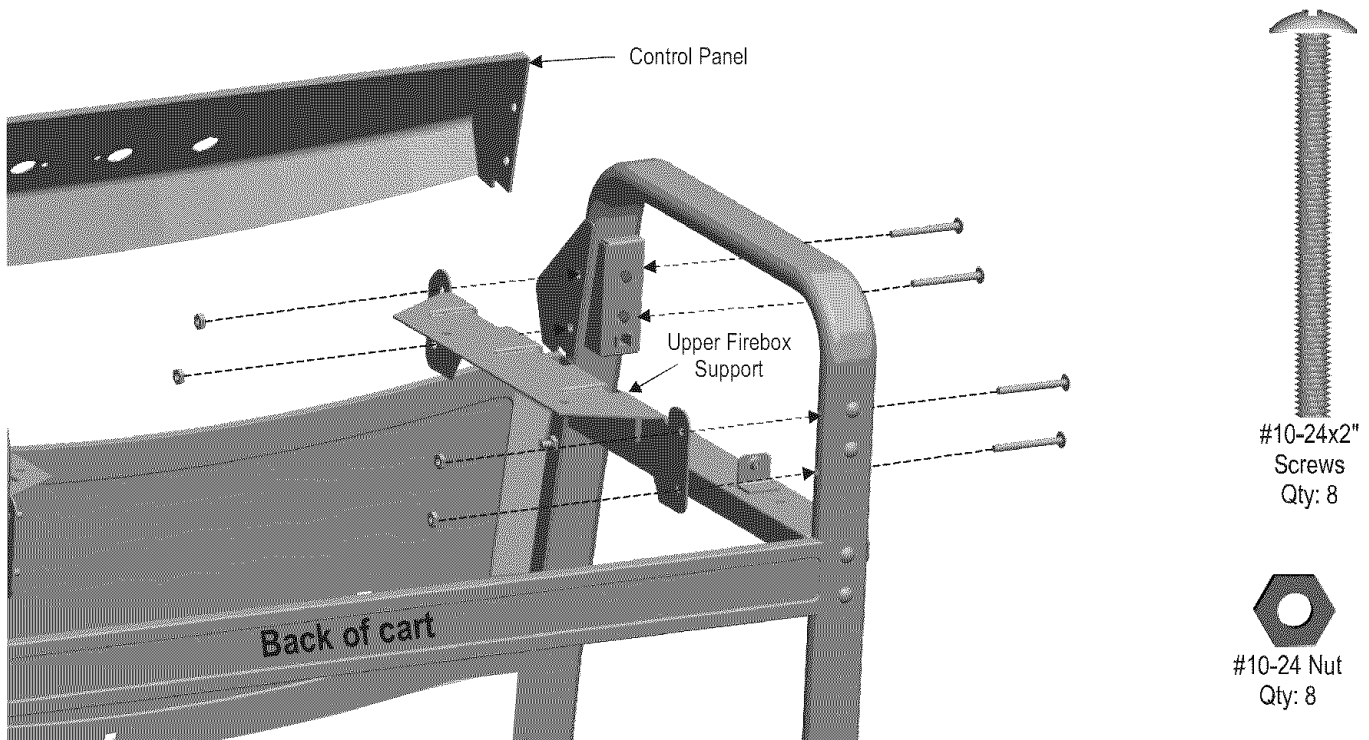

7

Valve/Hose/Regulator and Ignitor

- Attach valve/hose/regulator assembly to control panel with #10-24x1/2" screws.
- Insert round terminal lug of ignitor wire into the pin located on end of ignitor. Attach ignitor to control panel using the stamped nut that's provided.

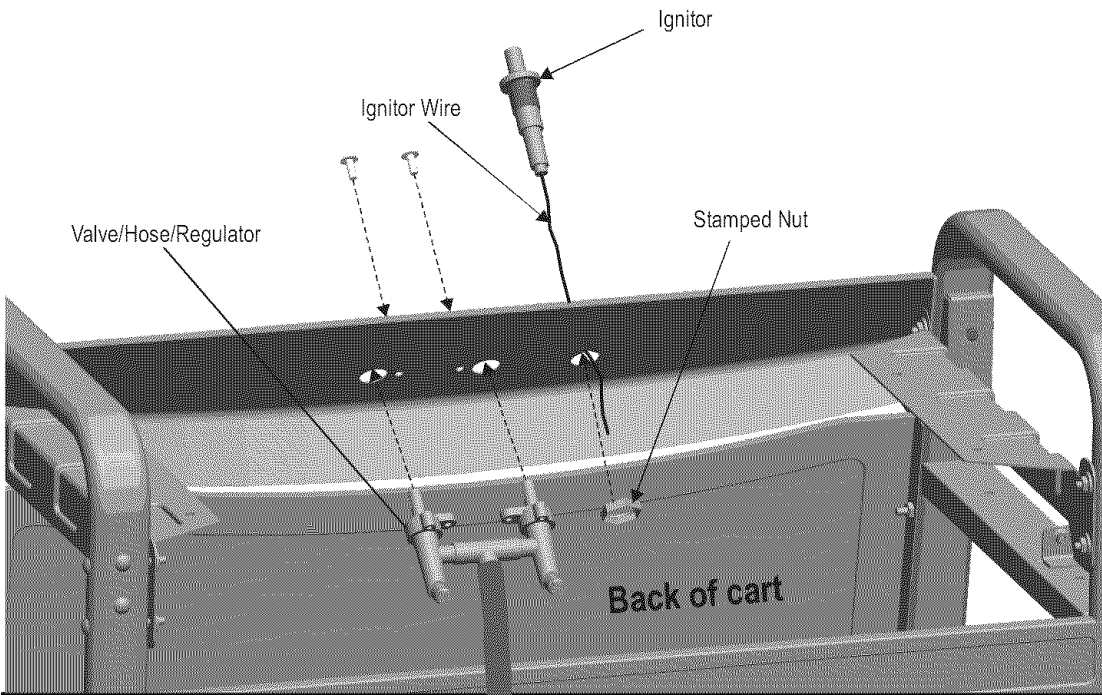

8

Heat Shield

- Attach heat shield with #10-24x1/2" screws and #10-24 nuts.

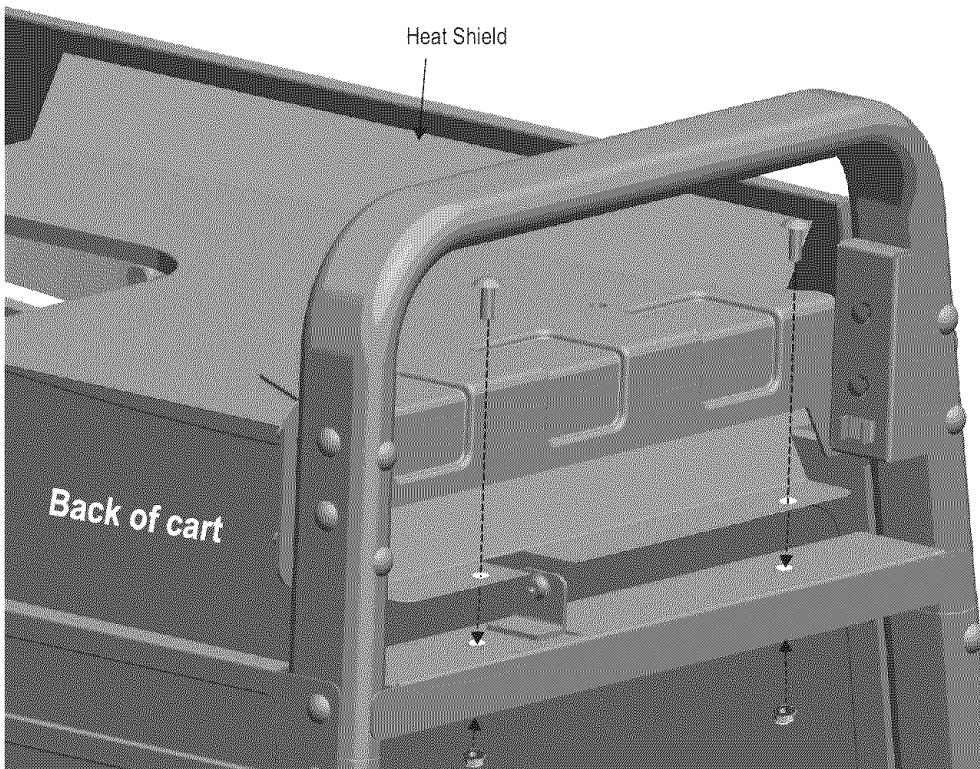

9

Tank Retainer

- Insert tank retainer into bracket and secure with wing screw.

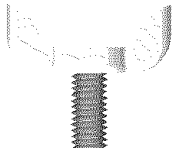

#10-24x3/8" Wing Screw
Qty: 1

Tank Retainer

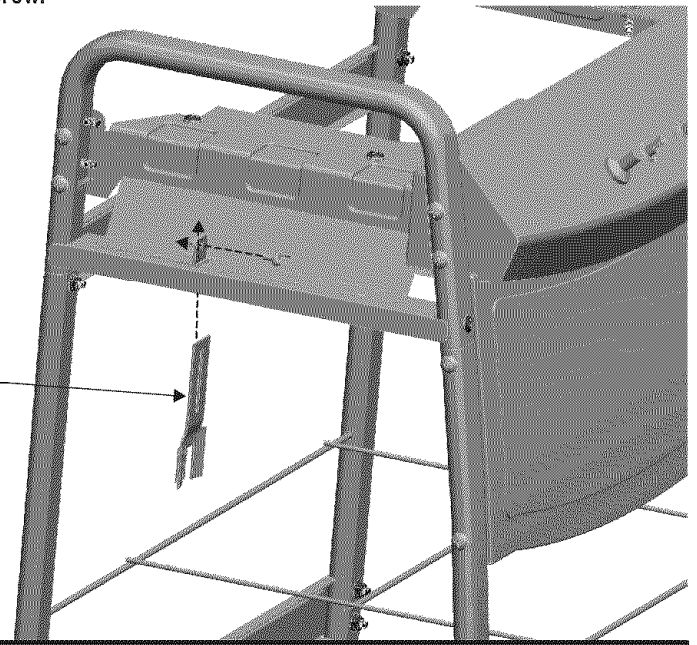

10

Burner, Firebox and Control Knobs

- Place burner assembly into firebox (A). Fasten the burner assembly to the firebox using 5mm fiber washers and #8 sheet metal screws. Insert #10-24x1-1/4" screws into each side of firebox. Inside firebox attach 5mm fiber washers and #10-24 nuts to screws.
- Place firebox onto upper firebox supports. Make sure burner tubes are correctly engaged (B). If burner is not leveled from left to right, adjust the two screws attaching valve to control panel. Attach short ignitor wire to ignitor (B).
- Attach firebox with #10-24x1-1/4" screws, 5mm fiber washers and #10-24 nuts (C).
- Push control knobs onto valve stems (C).

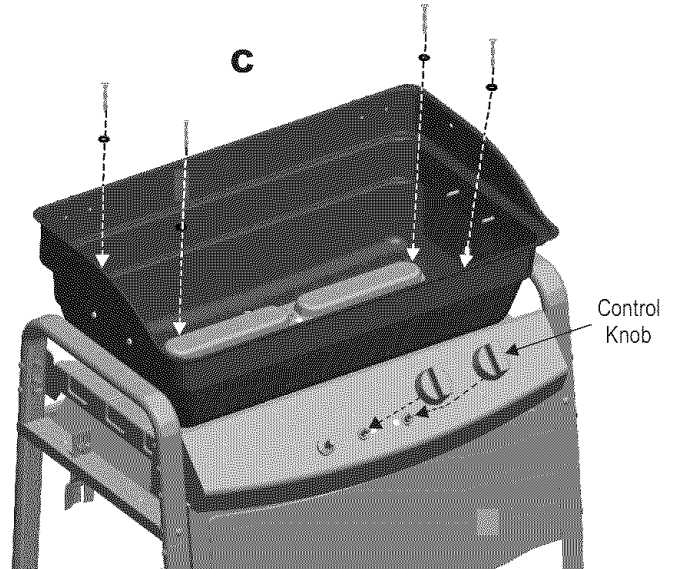
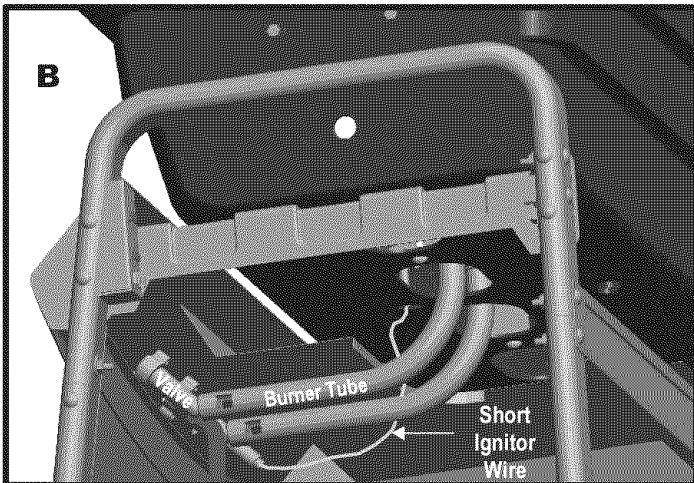
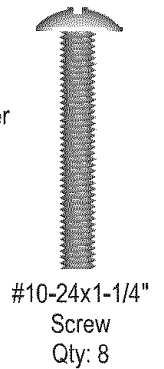
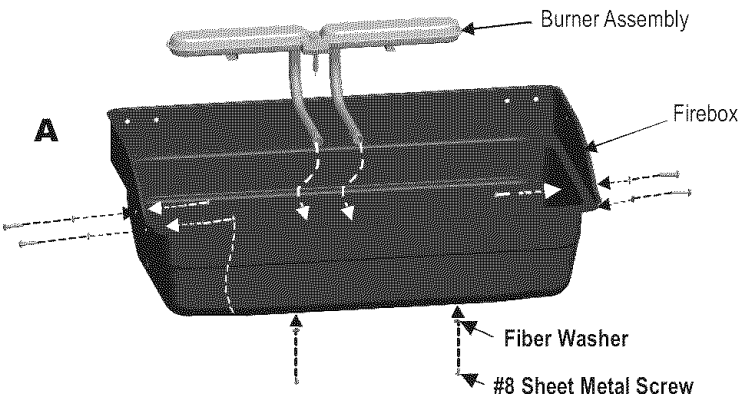

11

Shelves

- Insert mounting brackets into shelf supports with #10-24x1/2" screws (A).
- Attach mounting brackets to front of leg with #10-24x1/2" screws. Back of leg with #10-24x1-1/4" screw and #10-24 nuts (B).

NOTE: Right shelf has the tool holder.

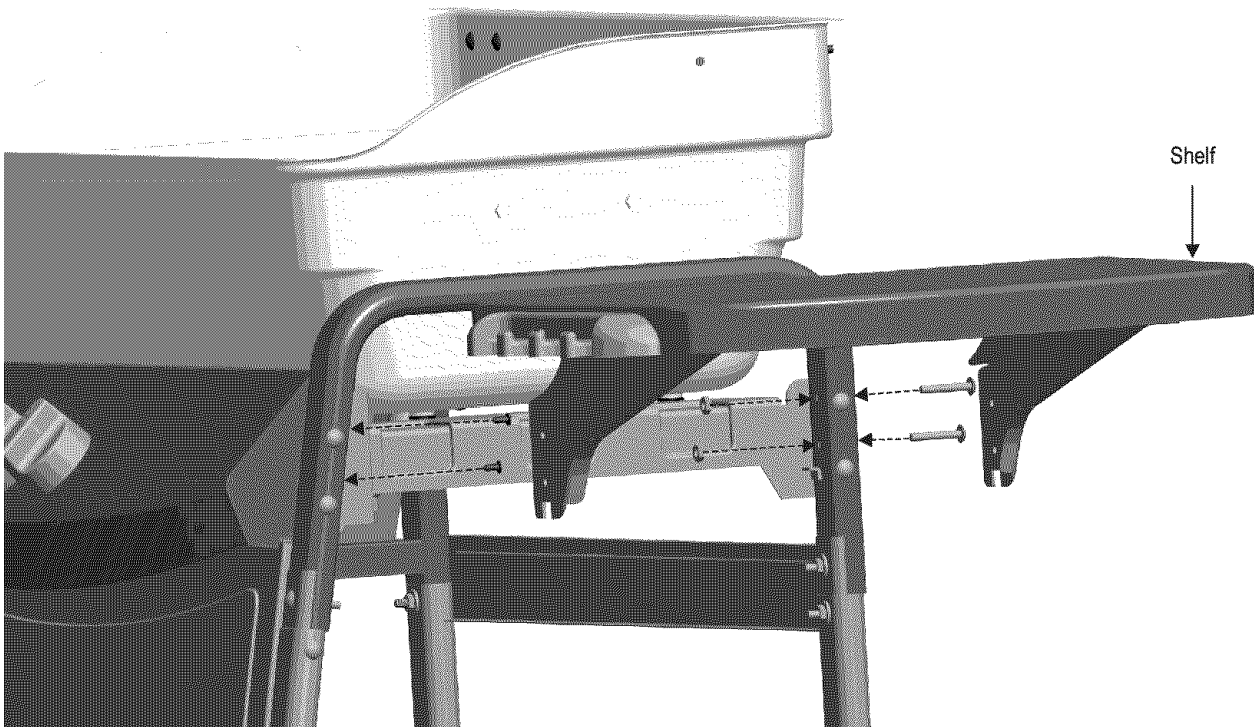
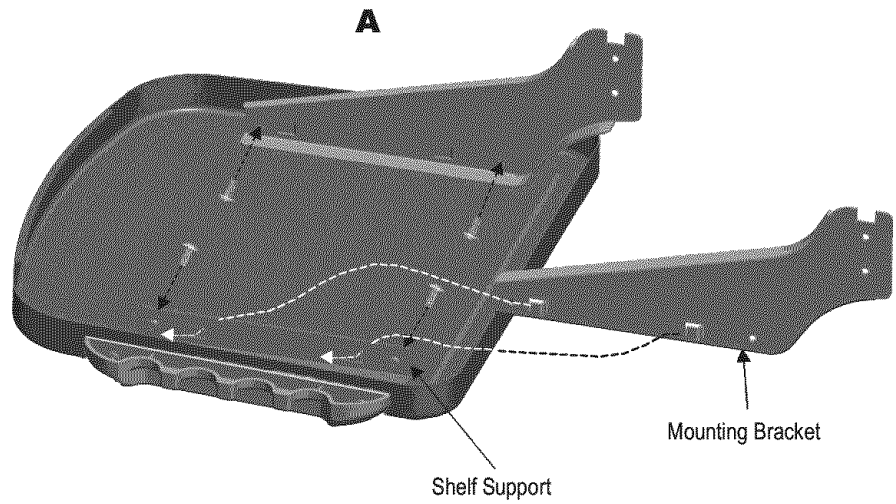
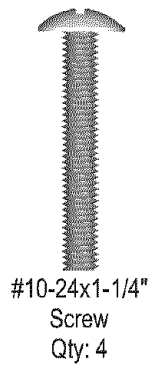

12

Lower Hinges

- Attach lower hinges to back of firebox using #10-24x1/2" screws, 5mm fiber washers and #10-24 nuts. The center flat portion of the hinge should be at the bottom (see inset).

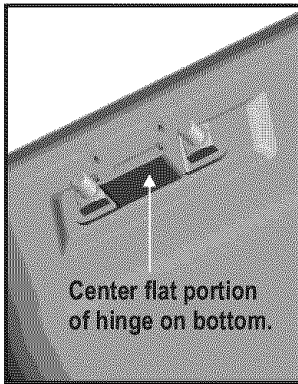

Lower Hinge

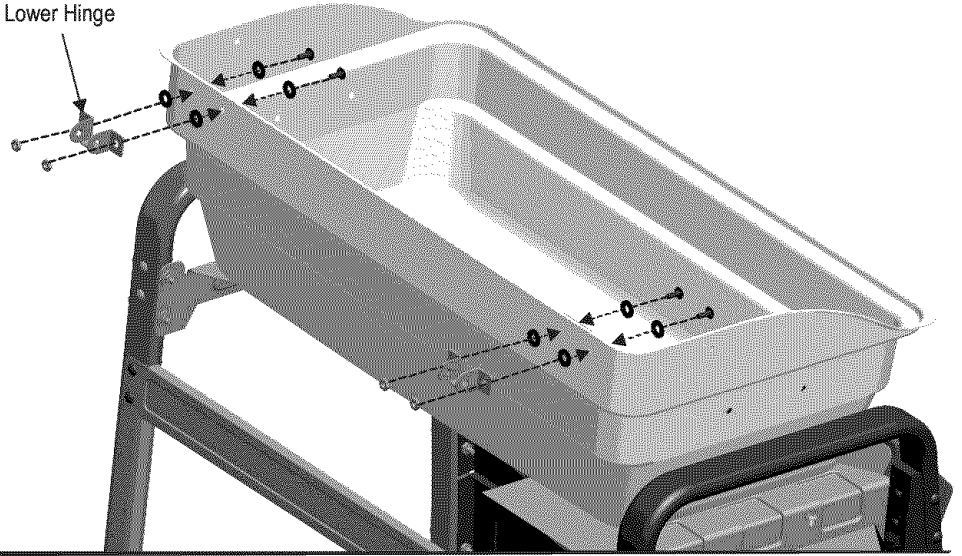

13

Lid Handle and Upper Hinges

- Attach handle to lid with 7mm fiber washers and wing nuts.
- Attach upper hinges to back of lid using #10-24x1/2" screws, 5mm fiber washers and #10-24 nuts. Hinges should curve downward when properly installed.

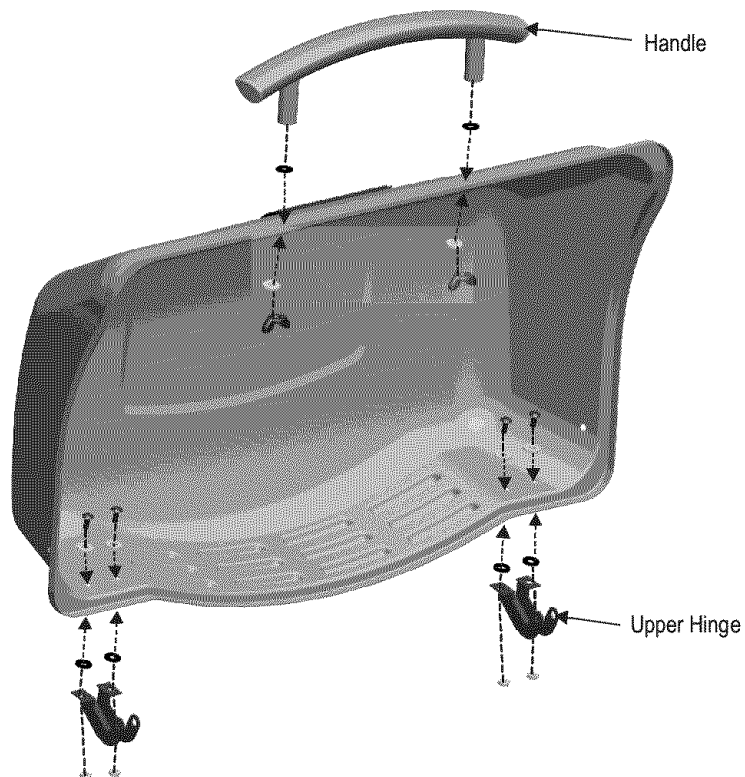

14

Lid

- Place lid assembly onto firebox, aligning hinges. Hinges on lid fit inside hinges on firebox. Secure using two hinge pins and hitch pins.



8
Qty: 2

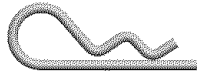

8
Qty: 2

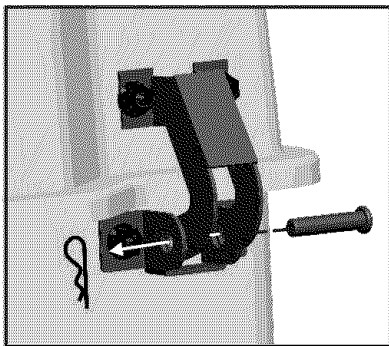

15

Heat Tent

- Place heat tent into firebox.

Heat Tent

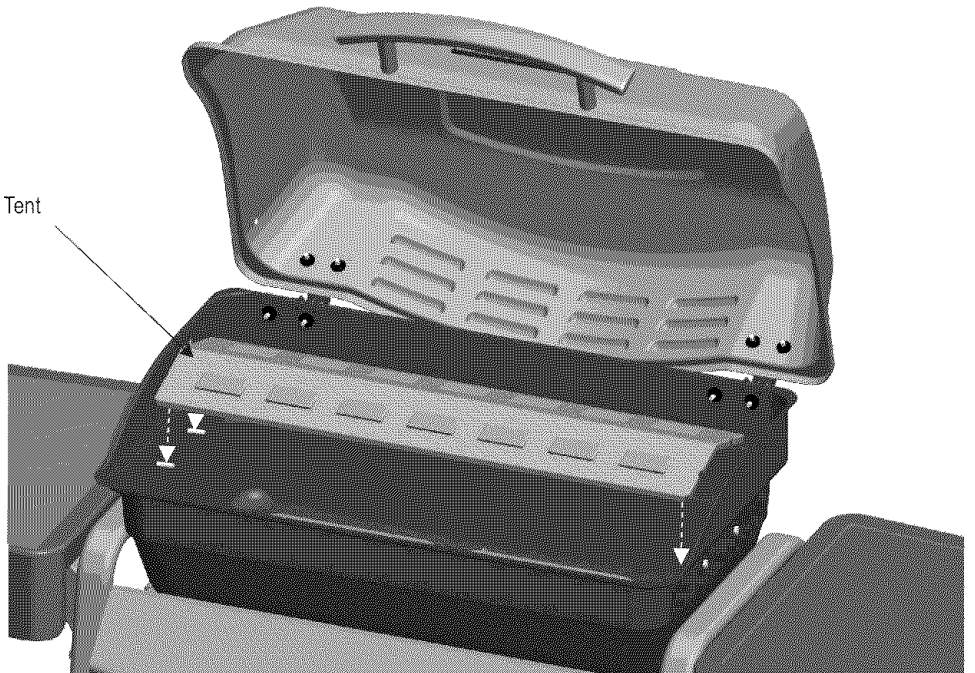

16

Cooking Grate

- Place grate into firebox.



17

Swing Away

- Insert ends of Swing Away pivot wire into holes in sides of grill lid. Insert ends of Swing Away leg wire into holes in sides of firebox. NOTE: Pivot and leg wires, running side-to-side, should be under wires running front-to-back. If pivot and leg wires are on top, Swing Away is installed upside-down.



18

Grease Cup Clip and Grease Cup

- Hang grease cup clip from bottom of firebox and place grease cup into grease clip.



Failure to install grease cup clip and cup will cause hot grease to drip from bottom of grill with risk of fire or property damage.

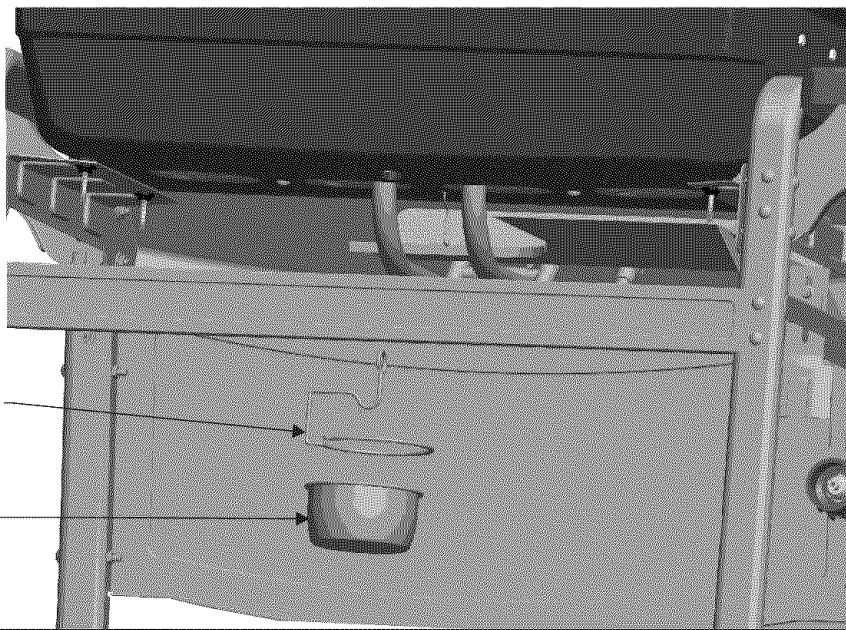

Grease Cup Clip

Grease Cup

19

LP Tank

- LP tank is sold separately. Use only with an OPD (over-fill protection device) equipped LP tank. Fill and leak check before attaching to grill and regulator.
- Tank collar opening must face to front of grill. Loosen wing nut from tank retainer bracket. Set bottom of tank onto notches in the tank bracket. Place tank retainer bracket onto tank collar and tighten the wing nut.

See Use and Care section to correctly Leak Test and perform the Burner Flame Check.



- Failure to install tank correctly may allow gas hose to be damaged in operation, resulting in the risk of fire.

LP Tank



Troubleshooting

EMERGENCIES: If a gas leak cannot be stopped, or a fire occurs due to gas leakage, call the fire department.

Emergencies	Possible Cause	Prevention/Solution
Gas leaking from cracked/cut/burned hose.	<ul style="list-style-type: none"> Damaged hose. 	<ul style="list-style-type: none"> Turn off gas at LP tank. If hose is cut or cracked, replace valve/hose/regulator. See LP Tank Leak Test and Connecting Regulator To The LP Tank.
Gas leaking from LP tank.	<ul style="list-style-type: none"> Mechanical failure due to rusting or mishandling. 	<ul style="list-style-type: none"> Turn off LP tank valve.
Gas leaking from LP tank valve.	<ul style="list-style-type: none"> Failure of tank valve from mishandling or mechanical failure. 	<ul style="list-style-type: none"> Turn off LP tank valve. Return LP tank to gas supplier.
Gas leaking between LP tank and regulator connection.	<ul style="list-style-type: none"> Improper installation, connection not tight, failure of rubber seal. 	<ul style="list-style-type: none"> Turn off LP tank valve. Remove regulator from cylinder and visually inspect rubber seal for damage. See LP Tank Leak Test and Connecting Regulator To The LP Tank.
Fire coming through control panel.	<ul style="list-style-type: none"> Fire in burner tube section of burner due to partial blockage. 	<ul style="list-style-type: none"> Turn off control knobs and LP tank valve. Leave lid open to allow flames to die down. After fire is out and grill is cold, remove burner and inspect for spider nests or rust. See Natural Hazard and Cleaning The Burner Assembly pages.
Troubleshooting: Problem	Possible Cause	Prevention/Solution
Grease fire or continuous excessive flames above cooking surface.	<ul style="list-style-type: none"> Too much grease buildup in burner area. 	<ul style="list-style-type: none"> Turn off LP tank valve. Leave lid open to allow flames to die down. After cooling, clean food particles and excess grease from inside firebox area, grease cup/pan/tray, and other surfaces.
Burner(s) will not light using ignitor.	<p>GAS ISSUES:</p> <ul style="list-style-type: none"> Trying to light wrong burner. Burner not engaged with control valve. Obstruction in burner. No gas flow. Vapor lock at coupling nut to LP tank. Coupling nut and LP tank valve not fully connected. 	<ul style="list-style-type: none"> See instructions on control panel and section in the Use and Care. Make sure valves are positioned inside of burner tubes. Ensure burner tubes are not obstructed with spider webs or other matter. See cleaning section of Use and Care. Make sure LP tank is not empty. If LP tank is not empty, refer to "Sudden drop in gas flow." Turn off knobs and disconnect coupling nut from LP tank. Reconnect and retry. Turn the coupling nut approximately one-half to three-quarters additional turn until solid stop. Tighten by hand only - do not use tools.
	<p>ELECTRICAL ISSUES:</p> <ul style="list-style-type: none"> Electrode cracked or broken; "sparks at crack." Electrode tip not in proper position. Wire and/or electrode covered with cooking residue. Wires are loose or disconnected. Wires are shorting (sparking) between ignitor and electrode. 	<ul style="list-style-type: none"> Replace electrode. Tip of electrode should be pointing toward port hole in burner. The distance should be 1/8" to 3/16". Adjust if necessary. Clean wire and/or electrode with rubbing alcohol and clean swab. Reconnect wires or replace electrode/wire assembly. Replace ignitor wire.

Continued on next page.

Troubleshooting (continued)

Problem	Possible Cause	Prevention/Solution
Burner(s) will not light using ignitor.	<ul style="list-style-type: none"> • Push-button sticks at bottom.. • Sparking between ignitor and electrode. 	<ul style="list-style-type: none"> • Replace ignitor. • Inspect wire insulation and proper connection. Replace wires if insulation is broken.
Burner(s) will not match light.	<ul style="list-style-type: none"> • See “GAS ISSUES:” on previous page. • Improper method of match-lighting. 	<ul style="list-style-type: none"> • See “Match-Lighting” section of Use and Care.
Sudden drop in gas flow or low flame.	<ul style="list-style-type: none"> • Out of gas. • Excess flow valve tripped. • Vapor lock at coupling nut/LP tank connection. 	<ul style="list-style-type: none"> • Check for gas in LP tank. • Turn off knobs, wait 30 seconds and light grill. If flames are still low, turn off knobs and LP tank valve. Disconnect regulator. Reconnect regulator and leak-test. Turn on LP tank valve, wait 30 seconds and then light grill. • Turn off knobs and LP tank valve. Disconnect coupling nut from tank. Reconnect and retry.
Flames blow out.	<ul style="list-style-type: none"> • High or gusting winds. • Low on LP gas. • Excess flow valve tripped. 	<ul style="list-style-type: none"> • Turn front of grill to face wind or increase flame height. • Refill LP tank. • Refer to “Sudden drop in gas flow” above.
Flare-up.	<ul style="list-style-type: none"> • Grease buildup. • Excessive fat in meat. • Excessive cooking temperature. 	<ul style="list-style-type: none"> • Clean burners and inside of grill/firebox. • Trim fat from meat before grilling. • Adjust (lower) temperature accordingly.
Persistent grease fire.	<ul style="list-style-type: none"> • Grease trapped by food buildup around burner system. 	<ul style="list-style-type: none"> • Turn knobs to OFF. Turn gas off at LP tank. Leave lid in position and let fire burn out. After grill cools, remove and clean all parts.
Flashback... (fire in burner tube(s)).	<ul style="list-style-type: none"> • Burner and/or burner tubes are blocked. 	<ul style="list-style-type: none"> • Turn knobs to OFF. Clean burner and/or burner tubes. See burner cleaning section of Use and Care manual.
Unable to fill LP tank.	<ul style="list-style-type: none"> • Some dealers have older fill nozzles with worn threads. 	<ul style="list-style-type: none"> • The worn nozzles don't have enough “bite” to engage the valve. Try a second LP dealer.
One burner does not light from other burner(s).	<ul style="list-style-type: none"> • Grease buildup or food particles in end(s) of carryover tube(s). 	<ul style="list-style-type: none"> • Clean carry-over tube(s) with wire brush.

LIMITED WARRANTY

Manufacturer warrants to the original consumer-purchaser only that this product shall be free from defects in workmanship and materials after correct assembly and under normal and reasonable home use for the periods indicated below beginning on the date of purchase.

The manufacturer reserves the right to require that defective parts be returned, postage and or freight pre-paid, by the consumer, for review and examination.

1 Year LIMITED warranty

Upon consumer supplying proof of purchase as provided herein, Manufacturer will repair or replace the parts listed below which are proven defective during the applicable warranty period. Parts required to complete such repair or replacement shall be free of charge to you except for shipping costs. **The original consumer-purchaser will be responsible for all shipping charges of parts replaced under the terms of this limited warranty.**

This limited warranty is applicable in the United States and Canada only, is only available to the original owner of the product and is not transferable. Manufacturer requires reasonable proof of your date of purchase. Therefore, you should retain your sales slip or invoice and register your new product immediately. Defective or missing parts subject to this limited warranty will not be replaced without registration or proof of purchase. Register online at <http://www.charbroil.com> or complete and return via mail the Product Registration Card located on the last page of the Use & Care manual included with this product and retain your sales receipt for proof of purchase.

This limited warranty applies to the functionality of the product ONLY and does not cover cosmetic issues such as scratches, dents, corrosion or discoloring by heat, abrasive and chemical cleaners or any tools used in the assembly or installation of the appliance, surface rust, or the discoloration of stainless steel surfaces.

This limited warranty will not reimburse you for the cost of any inconvenience, food, personal injury or property damage.

If an original replacement part is not available, a comparable replacement part will be sent. You will be responsible for all shipping charges of parts replaced under the terms of this limited warranty.

ITEMS MANUFACTURER WILL NOT PAY FOR:

1. Service calls to your home.
2. Repairs when your product is used for other than normal, single-family household or residential use.
3. Damage resulting from accident, alteration, misuse, abuse, fire, flood, acts of God, improper installation, installation not in accordance with electrical or plumbing codes, or use of products not approved by the manufacturer.
4. Any food loss due to product failures.
5. Replacement parts or repair labor costs for units operated outside the United States or Canada.
6. Pickup and delivery of your product.
7. Repairs to parts or systems resulting from unauthorized modifications made to the product.
8. The removal and/or reinstallation of your product.
9. Shipping cost, standard or expedited, for warranty and replacement parts.

DISCLAIMER OF IMPLIED WARRANTIES; LIMITATION OF REMEDIES

Repair or replacement of defect parts is your exclusive remedy under the terms of this limited warranty. Manufacturer will not be responsible for any consequential or incidental damages arising from the breach of either this limited warranty or any applicable warranty, or for failure or damage resulting from acts of God, improper care and maintenance, grease fire, accident, alteration, replacement of parts by anyone other than Manufacturer, misuse, transportation, commercial use, abuse, hostile environments (inclement weather, acts of nature, animal tampering), improper installation or installation not in accordance with local codes or printed manufacturer instructions. THIS LIMITED WARRANTY IS THE SOLE EXPRESS WARRANTY GIVEN BY THE MANUFACTURER. NO PRODUCT PERFORMANCE SPECIFICATION OR DESCRIPTION WHEREVER APPEARING IS WARRANTED BY MANUFACTURER EXCEPT TO THE EXTENT SET FORTH IN THIS LIMITED WARRANTY. ANY IMPLIED WARRANTY PROTECTION ARISING UNDER THE LAWS OF ANY STATE, INCLUDING IMPLIED WARRANTY OF MERCHANTABILITY OR FITNESS FOR A PARTICULAR PURPOSE OR USE, IS HEREBY LIMITED IN DURATION TO THE DURATION OF THIS LIMITED WARRANTY.

Neither dealers nor the retail establishment selling this product has any authority to make any additional warranties or to promise remedies in addition to or inconsistent with those stated above.

Manufacturer's maximum liability, in any event, shall not exceed the documented purchase price of the product paid by the original consumer.

This warranty only applies to units purchased from an authorized retailer and or re-seller.

NOTE: Some states do not allow an exclusion or limitation of incidental or consequential damages, so some of the above limitations or exclusions may not apply to you. This limited warranty gives you specific legal rights as set for herein. You may also have other rights which vary from state to state. In the state of California only, if refinishing or replacement of the product is not commercially practicable, the retailer selling this product or the Manufacturer will refund the purchase price paid for the product, less the amount directly attributable to use by the original consumer-purchaser prior to discovery of the nonconformity. In addition, in the state of California only, you may take the product to the retail establishment selling this product in order to obtain performance under this limited warranty.

If you wish to obtain performance of any obligation under this limited warranty, you should write to:

**Char-Broil Consumer Relations
P. O. Box 1240
Columbus, GA 31902-1240**

Consumer returns will not be accepted unless a valid Return Authorization is first acquired by calling 1-800-241-7548 and then clearly marked on the outside of the package and the package is shipped freight/postage pre-paid to the address above.

Please register your grill online at:

WWW.GRILLREGISTRATION.COM

(If you register online, you do not need to send in this registration card.)

PLEASE FILL OUT THIS CARD AND RETURN IT *WITHIN 10 DAYS OF PURCHASE. FAILURE TO RETURN MAY AFFECT YOUR WARRANTY COVERAGE.*
LLENE ESTA TARJETA Y DEVUÉLVALA DENTRO DE LOS 10 DÍAS DE LA COMPRA. *SI NO LA DEVUELVE, PUEDE VERSE AFECTADA SU COBERTURA DE GARANTÍA.*
VEUILLEZ COMPLÉTER CETTE CARTE ET LA RETOURNER DANS LES 10 JOURS SUIVANT L'ACHAT.
LA COUVERTURE DE VOTRE GARANTIE POURRAIT EN ÊTRE AFFECTÉE SI VOUS NE LE FAITES PAS.

1 First Name/Nombre/Prénom _____ Initial/Inicial/Initiale _____ Last Name/Apellido/Nom de famille _____
Address (number and street)/Dirección (número y calle)/Adresse (numéro et rue) _____ Apt Number/Nº de apart./Nº d'appt. _____
City/Ciudad/Ville _____ State/Estado/Province _____ Zip Code/Código zip/Code postal _____

2 E-mail Address/Dirección de correo electrónico/Adresse électronique _____
If you voluntarily provide us with your email address, you give us permission to use your email address to send you offers that may interest you.
Si nos informa voluntariamente su dirección de correo electrónico, nos da permiso para usarlo a fin de enviarle ofertas que pueden interesarle.
Si vous choisissez de nous fournir votre adresse électronique, vous nous donnez la permission de l'utiliser pour vous faire part d'offres spéciales susceptibles de vous intéresser.

(Example: your name@your host.com) (Ejemplo: su nombre@su host.com) (Exemple : votre nom@votre hôte.com)

3 Phone Number/Número telefónico/Numéro de téléphone _____

6 Date of Purchase/Fecha de compra/Date de l'achat _____

4 **IMPORTANT!/IMPORTANTE!/IMPORTANT!**
Write Serial Number and Model Number in spaces below.
Escriba en los espacios de abajo el número de serie y el número de modelo.
Inscrivez le numéro de série et le numéro de modèle dans les espaces ci-dessous.

7 Store Name/Nombre de la tienda/Nom du magasin _____

8 Purchase Price/Precio de compra/Prix d'achat
\$ _____ .00

5 Your Gender/Sexo/Sexe:

1. Male/Masculino/Masculin

2. Female/Femenino/Féminin

9 Which product are your registering?

¿Qué producto está registrando?

Quel produit enregistrez-vous?

1. Gas Grill/Parrilla a gas/
Gril au gaz
2. Electric Grill/Parrilla eléctrica/
Gril électrique
3. Smoker/Ahumador/Fumoir
4. Charcoal Grill/Parrilla a carbón/
Barbecue au charbon
5. Charcoal Smoker/Ahumador a
carbón/Fumoir au charbon
6. Outdoor Fireplace/Chimenea para
exteriores/Foyer extérieur
7. Cooker/Fryer / Cocina/freidora /
Cuiseur/Friteuse
8. Other/Otro/Autre

10 Which of these sources influenced your decision to buy this product? (check all that apply)

¿Cuál de estas fuentes influyó a su decisión de comprar este producto? (Marque todas las que correspondan)

Parmi les éléments ci-dessous, qu'est-ce qui a influencé votre décision d'acheter ce produit? (Cochez tous les éléments s'appliquant)

1. Magazine/newspaper advertisement / Propaganda en revista/periódico /
Publicité dans un magazine ou dans un journal
2. Television commercial/Comercial televisivo/Publicité à la télévision
3. Grill was assembled/La parrilla estaba ensamblada/Le gril était déjà assemblé
4. In-store display/Exhibidor en la tienda/Promotion sur le lieu de vente
5. Store circular/Circular de la tienda/Prospectus de magasin
6. Brand name/Marca/ Marque
7. Product style/Estilo del producto/Style du produit
8. Price/value / Precio/valor / Rapport prix/valeur
9. Product quality/Calidad del producto/Qualité du produit
10. Friend/Relative recommendation / Recomendación de amigo o pariente /
Recommandation d'un(e) ami(e)/parent(e)
11. Salesperson recommendation/Recomendación del vendedor/
Recommandation d'un(e) préposé(e) à la vente
12. Grill size/Tamaño de la parrilla/Taille du gril
13. Product warranty/Garantía del producto/Garantie du produit
14. Store demonstration/Demostración en la tienda/Démonstration en magasin
15. Point of purchase/Punto de compra/Lieu de vente
16. Other/Otras/Autre: _____

Mail to: / Envíelo a:

Product Registration Dept.

PO BOX 1240

Columbus, Georgia 31902-1240

Thank you for completing this questionnaire. Your answers will help us and other companies reach you with offers that may interest you. If you prefer not to receive these offers, please check here .

Gracias por completar este cuestionario. Sus respuestas nos ayudarán, a nosotros y a otras compañías, a llegar a usted con ofertas que puedan resultarle de interés. Si prefiere no recibir estas ofertas, por favor marque aquí .

Merci d'avoir bien voulu remplir ce questionnaire. Vos réponses nous aideront et aideront d'autres compagnies à vous communiquer des offres spéciales susceptibles de vous intéresser. Si vous préférez ne pas recevoir d'informations concernant ces offres spéciales, veuillez cocher ici .

STOP

Should you encounter a problem with our product

CALL US FIRST

Do not return this product to the store.

WE CAN HELP

GRILL SERVICE CENTER

1-800-241-7548

HOURS 8AM-6PM EST Mon-Fri

Please ensure your warranty registration is complete.

Grilling Safety Checklist

- Read and understand owners manual.
- Never overfill LP cylinder. Overfilled cylinders may cause freeze-up of regulator.
- Check tubes for spider webs. Ensure valves are correctly installed in burner tubes.
- Always ensure control knobs are in OFF position and regulator is attached to tank BEFORE opening tank valve to avoid low flames.
- Perform leak test regularly.

Thank You for Your Purchase!

