



## Liquid Propane Gas Grill

Kenmore Model No. 415.16117

Kmart Item No. 640-104261-110

This Grill Is For  
Outdoor Use Only

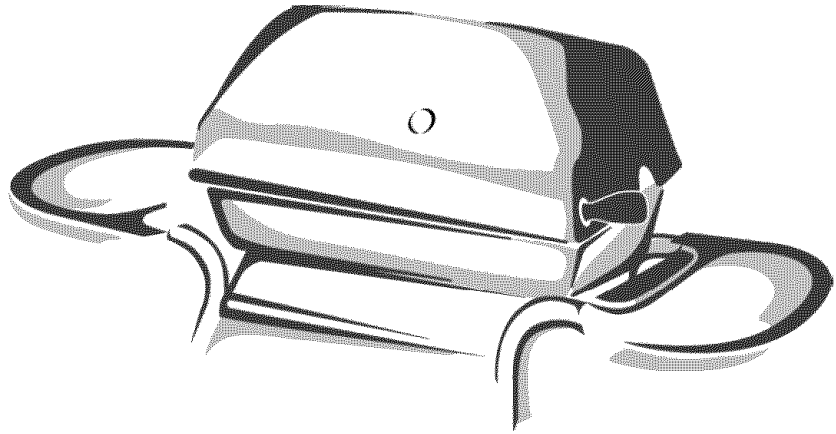

	<b>WARNING</b>	
<ul style="list-style-type: none"><li>• Read this manual before cooking on grill. Failure to follow all manufacturer's instructions could result in fire or explosion which could cause property damage, personal injury or death.</li><li>• Combustion by-products produced when using this product contain chemicals known to the State of California to cause cancer, birth defects, or other reproductive harm.</li></ul>		

	<b>CAUTION</b>	
<ul style="list-style-type: none"><li>• Read and follow all Safety Statements, Assembly Instructions and Use &amp; Care Directions before attempting to assemble and cook.</li><li>• Some parts may contain sharp edges, especially as noted in these instructions. Wear protective gloves if necessary.</li></ul>		

- Parts
- Assembly
- Safety Rules
- Use and Care
- Troubleshooting
- Español



Assembly Questions?  
Call 1-800-241-7548



Parts Ordering:  
Call 1-800-4-MY-HOME®

To Installer/Assembler: Leave these instructions with consumer.

To Consumer: Keep this manual for future reference.

Sears, Roebuck and Co., Hoffman Estates, IL 60179 U.S.A.

	<b>DANGER</b>	
<p><b>If you smell gas:</b></p> <ol style="list-style-type: none"> <li>1. Shut off gas to the appliance.</li> <li>2. Extinguish any open flame.</li> <li>3. Open lid.</li> <li>4. If odor continues, keep away from the appliance and immediately call your gas supplier or your fire department.</li> </ol>		

	<b>WARNING</b>	
<ol style="list-style-type: none"> <li>1. Do not store or use gasoline or other flammable liquids or vapors in the vicinity of this or any other appliance.</li> <li>2. An LP cylinder not connected for use shall not be stored in the vicinity of this or any other appliance.</li> </ol>		

**Call Grill Service Center For Help And Parts**

If you have questions or need assistance during assembly, please call **1-800-241-7548**. You will be speaking to a representative of the grill manufacturer and not a Sears employee. To order new parts call Sears at **1-800-4-MY-HOME®**.

**Product Record**



**IMPORTANT:** Fill out the product record information below.

Model Number _____
Serial Number _____ <small style="margin-left: 100px;">See rating label on grill for serial number.</small>
Date Purchased _____



	<b>CAUTION</b>	
<p><b>For residential use only. Do not use for commercial cooking.</b></p>		

**Safety Symbols**

The symbols and boxes shown below explain what each heading means. Read and follow all of the messages found throughout the manual.

	<b>DANGER</b>	
<p><b>DANGER:</b> Indicates an imminently hazardous situation which, if not avoided, will result in death or serious injury.</p>		

	<b>WARNING</b>	
<p><b>WARNING:</b> Be alert to the possibility of serious bodily injury if the instructions are not followed. Be sure to read and carefully follow all of the messages.</p>		

	<b>CAUTION</b>	
<p><b>CAUTION:</b> Indicates a potentially hazardous situation which, if not avoided, may result in minor or moderate injury.</p>		

**Installation Safety Precautions**

- Use grill, as purchased, only with LP (propane) gas and the regulator/valve assembly supplied.
- Grill installation must conform with local codes, or in their absence of local codes, with either the *National Fuel Gas Code, ANSI Z223.1/NFPA 54, Natural Gas and Propane Installation Code, CSA B149.1, or Propane Storage and Handling Code, B149.2, or the Standard for Recreational Vehicles, ANSI A 119.2/NFPA 1192, and CSA Z240 RV Series, Recreational Vehicle Code, as applicable.*
- All electrical accessories (such as rotisserie) must be electrically grounded in accordance with local codes, or *National Electrical Code, ANSI / NFPA 70*. Keep any electrical cords and/or fuel supply hoses away from any hot surfaces.
- Grill is not for use in or on recreational vehicles and/or boats.
- This grill is safety certified for use in the United States only. Do not modify for use in any other location. Modification will result in a safety hazard.

## TABLE OF CONTENTS

For Your Safety . . . . .	2
Grill Service Center . . . . .	2
Product Record Information . . . . .	2
Safety Symbols . . . . .	2
Installation Safety Precautions . . . . .	2
Kenmore Grill Warranty . . . . .	3
Use and Care . . . . .	4-11
Parts List . . . . .	12
Parts Diagram . . . . .	13
Assembly . . . . .	14-24
Troubleshooting . . . . .	25-27

### Repair Protection Agreements

*Congratulations on making a smart purchase. Your new Kenmore® product is designed and manufactured for years of dependable operation. But like all products, it may require repair from time to time. That's when having a Repair Protection Agreement can save you money and aggravation.*

*Purchase a Repair Protection Agreement now and protect yourself from unexpected hassle and expense.*

Here's what's included in the Agreement:

- ✓ **Expert service** by our 12,000 professional repair specialists
- ✓ **Unlimited service and no charge** for parts and labor on all covered repairs
- ✓ **Product replacement** if your covered product can't be fixed
- ✓ **Discount of 10%** from regular price of service and service-related parts not covered by the agreement; also, 10% off regular price of preventive maintenance check
- ✓ **Fast help by phone** – phone support from a Sears technician on products requiring in-home repair, plus convenient repair scheduling

Once you purchase the Agreement, a simple phone call is all that it takes for you to schedule service. You can call anytime day or night, or schedule a service appointment online.

Sears has over 12,000 professional repair specialists, who have access to over 4.5 million quality parts and accessories. That's the kind of professionalism you can count on to help prolong the life of your new purchase for years to come. Purchase your Repair Protection Agreement today!

**Some limitations and exclusions apply.**

**For prices and additional information call 1-800-827-6655.**

### Sears Installation Service

*For Sears professional installation of home appliances, garage door openers, water heaters, and other major home items, in the U.S.A. call 1-800-4-MY-HOME®*

## WARRANTY

### One-Year Full Warranty on Kenmore Grill

If this grill fails due to a defect in material or workmanship within one year from the date of purchase, call 1-800-4-MY-HOME® to arrange for free repair (or replacement if repair proves impossible).

### Five-Year Limited Warranty on Stainless Steel Burners

For five years from the date of purchase, any stainless steel burner that rusts through will be replaced free of charge. After the first year from the date of purchase, you pay for labor if you wish to have it installed.

All warranty coverage excludes ignitor batteries and grill part paint loss, discoloration or rusting, which are either expendable parts that can wear out from normal use within the warranty period, or are conditions that can be the result of normal use, accident or improper maintenance.

All warranty coverage is void if this grill is ever used for commercial or rental purposes.

All warranty coverage applies only if this grill is used in the United States.

This warranty gives you specific legal rights, and you may have other rights which vary from state to state.

**Sears, Roebuck and Co., Hoffman Estates, IL 60179**

## USE AND CARE



# DANGER



- **NEVER** store a spare LP tank under or near grill or in enclosed areas

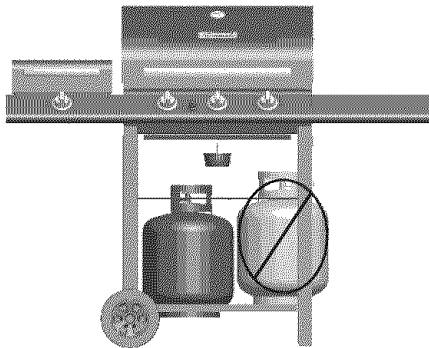

- Never fill the cylinder beyond 80% full.
- An overfilled or improperly stored tank is a hazard due to possible gas release from the safety relief valve. This could cause an intense fire with risk of property damage, serious injury or death.
- If you see, smell or hear escaping gas, immediately get away from the LP tank/grill and call your fire department.

### LP Tank Removal, Transport And Storage

- Turn OFF all control knobs and LP tank valve. Turn coupling nut counterclockwise by hand only - do not use tools to disconnect. Lift LP tank wire upward off of LP tank collar, then lift LP tank up and off of support bracket. Install safety cap onto LP tank valve. Always use cap and strap supplied with valve. **Failure to use safety cap as directed may result in serious personal injury and/or property damage.**

LP Tank Valve

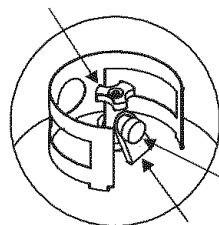

Safety Cap

Retainer Strap

- A disconnected LP tank in storage or being transported must have a safety cap installed (as shown). Do not store an LP tank in enclosed spaces such as a carport, garage, porch, covered patio or other building. Never leave an LP tank inside a vehicle which may become overheated by the sun.
- Do not store an LP tank in an area where children play.

### LP Tank

- The LP tank used with your grill must meet the following requirements:
- Use LP tanks only with these required measurements: 12" (30.5cm) (diameter) x 18" (45.7 cm) (tall) with 20 lb. (9 kg.) capacity maximum.
- LP tanks must be constructed and marked in accordance with specifications for LP tank of the U.S. Department of Transportation (DOT). See LP tank collar for marking.
- LP tank valve must have:
  - Type 1 outlet compatible with regulator or grill.
  - Safety relief valve.
  - UL listed Overfill Protection Device (OPD). This OPD safety feature is identified by a unique triangular hand wheel. **Use only LP tanks equipped with this type of valve.**
- LP tank must be arranged for vapor withdrawal and include collar to protect LP tank valve.

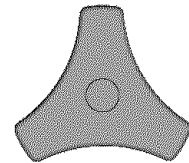

OPD Hand Wheel

### LP (Liquefied Petroleum Gas)

- LP gas is nontoxic, odorless and colorless when produced. **For Your Safety**, LP gas has been given an odor (similar to rotten cabbage) so that it can be smelled.
- LP gas is highly flammable and may ignite unexpectedly when mixed with air.

### LP Tank Filling

- Use only licensed and experienced dealers.
- LP dealer **must purge tank** before filling.
- Dealer should **NEVER** fill LP tank more than 80% of LP tank volume. Volume of propane in tank will vary by temperature.
- A frosty regulator indicates gas overfill. Immediately close LP tank valve and call local LP gas dealer for assistance.
- Do not release liquid propane (LP) gas into the atmosphere. This is a hazardous practice.
- To remove gas from LP tank, contact an LP dealer or call a local fire department for assistance. Check the telephone directory under "Gas Companies" for nearest certified LP dealers.

## LP Tank Exchange

- Many retailers that sell grills offer you the option of replacing your empty LP tank through an exchange service. Use only those reputable exchange companies that inspect, precision fill, test and certify their cylinders. **Exchange your tank only for an OPD safety feature-equipped tank as described in the "LP Tank" section of this manual.**
- Always keep new and exchanged LP tanks in upright position during use, transit or storage.
- **Leak test new and exchanged LP tanks BEFORE connecting to grill.**

## LP Tank Leak Test

### For your safety

- Leak test must be repeated each time LP tank is exchanged or refilled.
- Do not smoke during leak test.
- Do not use an open flame to check for gas leaks.
- Grill must be leak tested outdoors in a well-ventilated area, away from ignition sources such as gas fired or electrical appliances. During leak test, keep grill away from open flames or sparks.
- Use a clean paintbrush and a 50/50 mild soap and water solution. Brush soapy solution onto areas indicated by arrows in figure below. Leaks are indicated by growing bubbles.

	<b>WARNING</b>	
If "growing" bubbles appear do not use or move the LP tank. Contact an LP gas supplier or your fire department!		

- ▲ **Do not use household cleaning agents.** Damage to gas train components can result.

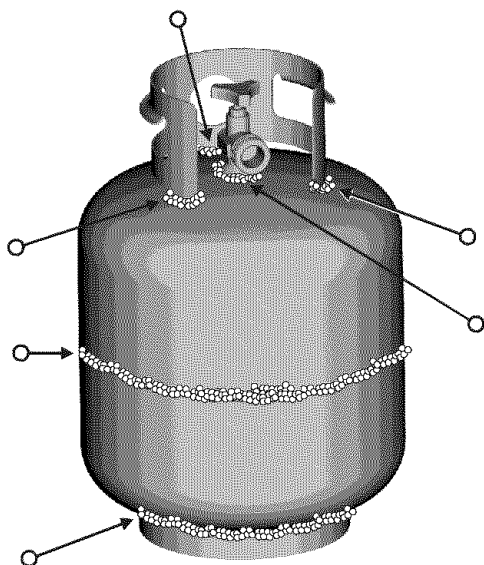

## Connecting Regulator To The LP Tank

1. LP tank must be properly secured onto grill. (Refer to assembly section.)
2. Turn all control knobs to the OFF position.
3. Turn LP tank OFF by turning OPD hand wheel clockwise to a full stop.
4. Remove the protective cap from LP tank valve. Always use cap and strap supplied with valve.

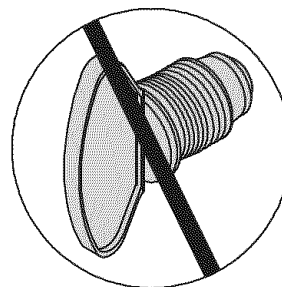
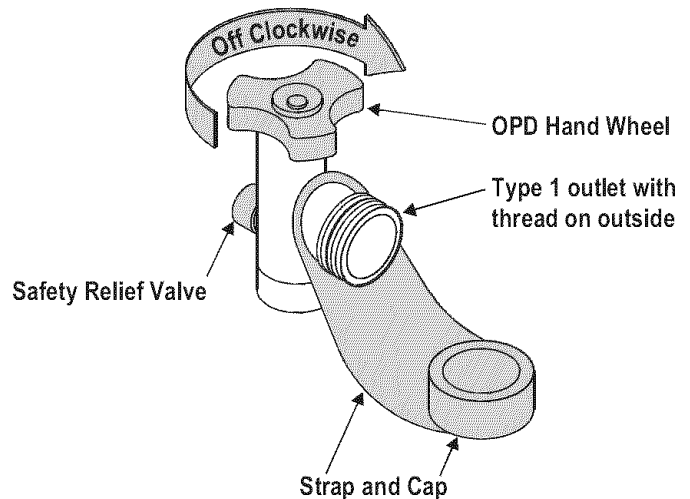

**Do not use a POL transport plug (plastic part with external threads)! It will defeat the safety feature of the valve.**

5. Hold regulator and insert nipple into LP tank valve. Hand-tighten the coupling nut, holding regulator in a straight line with LP tank valve so as not to cross-thread the connection.

**Nipple has to be centered into the LP tank valve.**

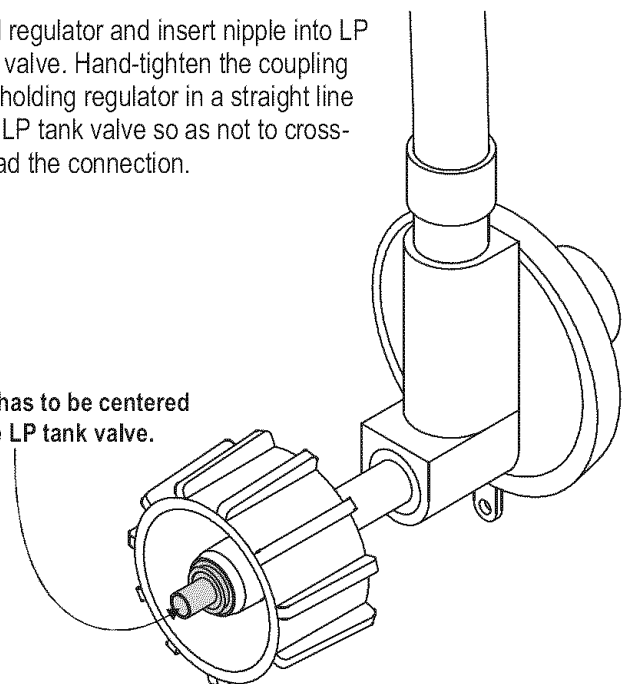

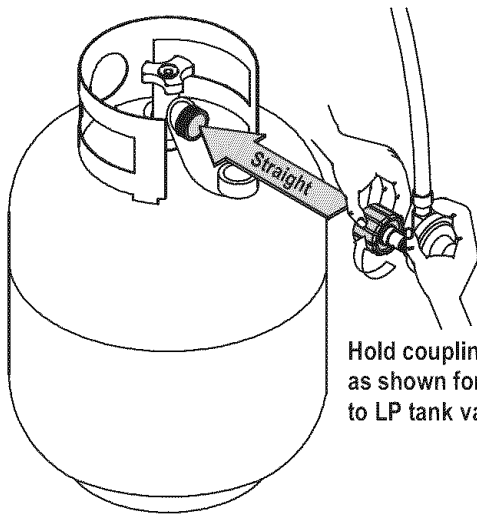

Hold coupling nut and regulator as shown for proper connection to LP tank valve.

6. Turn the coupling nut clockwise and tighten to a full stop. The regulator will seal on the back-check feature in the LP tank valve, resulting in some resistance. **An additional one-half to three-quarters turn is required to complete the connection. Tighten by hand only – do not use tools.**

**NOTE:**

If you cannot complete the connection, disconnect regulator and repeat steps 5 and 6. If you are still unable to complete the connection, **do not use this regulator!**

	<b>DANGER</b>	
<ul style="list-style-type: none"> <li>• Do not insert any tool or foreign objects into the valve outlet or safety relief valve. You may damage the valve and cause a leak. Leaking propane may result in explosion, fire, severe personal injury, or death..</li> <li>• If a leak is detected at any time, STOP and call the fire department.</li> <li>• If you cannot stop a gas leak, <i>immediately</i> close LP tank valve and call LP gas supplier or your fire department!</li> </ul>		

	<b>WARNING</b>	
<ul style="list-style-type: none"> <li>• Never attempt to attach this grill to the self-contained LP gas system of a camper trailer or motor home.</li> <li>• Do not use grill until leak-tested.</li> </ul>		

**Leak Testing Valves, Hose and Regulator**

1. Turn all grill control knobs to OFF.
2. Be sure regulator is tightly connected to LP tank.
3. Completely open LP tank valve by turning OPD hand wheel counterclockwise. If you hear a *rushing sound*, turn gas off immediately. There is a major leak at the connection. **Correct before proceeding** by calling Sears for replacement parts at **1-800-4-MY-HOME®**.
4. Brush soapy solution onto areas where bubbles are shown in picture below:



5. If **“growing”** bubbles appear, there is a leak. Close LP tank valve immediately and retighten connections. **If leaks cannot be stopped do not try to repair.** Call Sears for replacement parts at **1-800-4-MY-HOME®**.
6. Always close LP tank valve after performing leak test by turning hand wheel clockwise.



## WARNING



### For Safe Use Of Your Grill And To Avoid Serious Injury:

- Do not let children operate or play near grill.
- Keep grill area clear and free from materials that burn.
- Do not block holes in bottom or back of grill.
- Check burner flames regularly.
- Use grill only in well-ventilated space. NEVER use in enclosed space such as carport, garage, porch, covered patio, or under an overhead structure of any kind.
- Do not use charcoal or ceramic briquets in a gas grill. *(Unless briquets are supplied with your grill.)*
- **Use grill at least 3 ft. from any wall or surface.** Maintain 10 ft. clearance to objects that can catch fire or sources of ignition such as pilot lights on water heaters, live electrical appliances, etc.

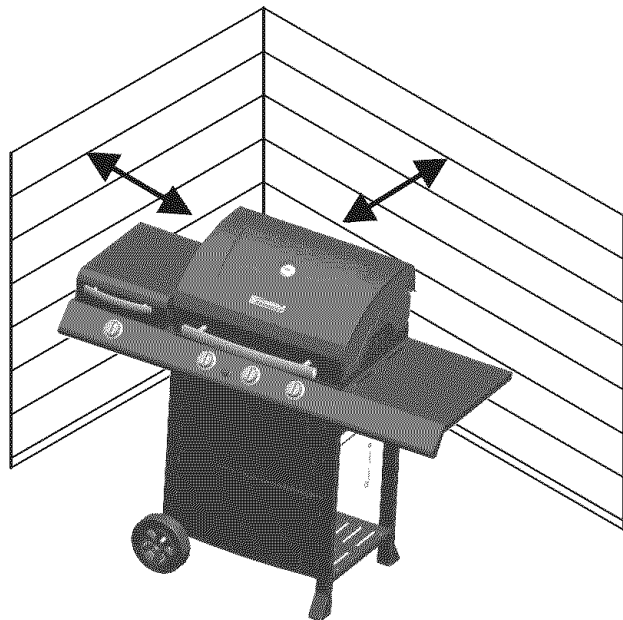

#### • Apartment Dwellers:

Check with management to learn the requirements and fire codes for using an LP gas grill in your apartment complex. If allowed, use outside on the ground floor with a three (3) foot clearance from walls or rails. Do not use on or under balconies.

- **NEVER attempt to light burner with lid closed. A buildup of non-ignited gas inside a closed grill is hazardous.**
- **Never operate grill with LP tank out of correct position specified in assembly instructions.**
- **Always close LP tank valve and remove coupling nut before moving LP tank from specified operation position.**

### Safety Tips

- ▲ Before opening LP tank valve, check the coupling nut for tightness.
- ▲ When grill is not in use, turn off all control knobs and LP tank valve.
- ▲ Never move grill while in operation or still hot.
- ▲ Use long-handled barbecue utensils and oven mitts to avoid burns and splatters.
- ▲ Maximum load for shelves is 10 lbs.
- ▲ Do not use a cooking pot larger than 9" on grid.
- ▲ The grease cup **must** be attached to grease cup clip and emptied after each use. Do not remove grease cup until grill has completely cooled.
- ▲ If you notice grease or other hot material dripping from grill onto valve, hose or regulator, turn off gas supply at once. Determine the cause, correct it, then clean and inspect valve, hose and regulator before continuing. Perform a leak test.
- ▲ The regulator may make a humming or whistling noise during operation. This will not affect safety or use of grill.
- ▲ If you have a grill problem see the "Troubleshooting Section".



## WARNING



If the regulator frosts, turn off grill and LP tank valve immediately. This indicates a problem with the tank and it should not be used on any product. Return to supplier!

	<b>CAUTION</b>	
<ul style="list-style-type: none"> <li>• Putting out grease fires by closing the lid is not possible. Grills are well ventilated for safety reasons.</li> <li>• Do not use water on a grease fire. Personal injury may result. If a grease fire develops, turn knobs and LP tank off.</li> <li>• Do not leave grill unattended while preheating or burning off food residue on high. If grill has not been regularly cleaned, a grease fire can occur that may damage the product. Follow instructions on General Grill Cleaning and Cleaning The Burner Assembly to prevent grease fires.</li> </ul>		

### Main Burner Ignitor Lighting

- ▲ Do not lean over grill while lighting.
- 1. Open lid during lighting.
- 2. To ignite, turn IGNITION BURNER knob to 🔥.
- 3. Push and hold ELECTRONIC IGNITION button.
- 4. If ignition does NOT occur in 5 seconds, turn the burner controls off, wait 5 minutes, and repeat the lighting procedure.
- 5. Ignite other burners by turning knob to 🔥.
- 6. If ignitor does not work, wait 5 minutes, then follow match lighting instructions.

	<b>CAUTION</b>	
<p>If burner does not light, turn knobs to OFF, wait 5 minutes, and try again. Always close valve during the 5 minute waiting period. If the burner does not ignite with the valve open, gas will continue to flow out of the burner and could accidentally ignite with risk of injury.</p>		

### Match-Lighting

- ▲ Do not lean over grill while lighting.
- 1. Open lid during lighting. Turn on gas at LP tank.
- 2. Place match into match holder (hanging from side of cart). Light match, place into lighting hole on right side of firebox.
- 3. Push in and turn right knob to HIGH position. Be sure burner lights and stays lit.
- 4. Light other burners by pushing knob in and turning to 🔥 HIGH position.

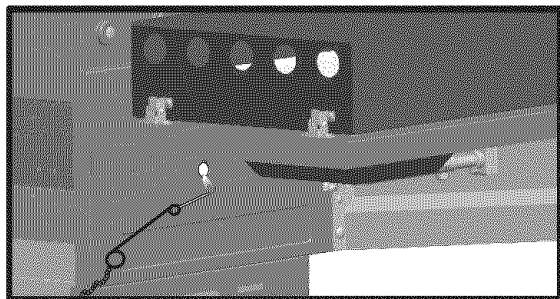

### Sideburner Ignitor Lighting

1. Top cover must be open when burner is operational.
2. To ignite SIDEBURNER, open sideburner cover.
3. Turn sideburner knob to 🔥, push and hold ELECTRONIC IGNITOR button.
4. If sideburner does NOT light in 5 seconds, turn knob to OFF, wait 5 minutes, then repeat lighting procedure.

### Sideburner Match Lighting

1. Open top cover. Turn on gas at LP tank.
2. Hold lit match to any port on the burner. Push in and turn sideburner knob to 🔥 HIGH. Be sure burner lights and stays lit.

### Before Your First Cookout

- Light burners, check to make sure they are lit, close the lid and warm up grill on HIGH for 15 minutes. This curing of paint and parts will produce an odor only on first lighting.

### Burner Flame Check

- Light burner, rotate knobs from HIGH to LOW. You should see a smaller flame in LOW position than seen on HIGH. Always check flame prior to each use. If only low flame is seen refer to "Sudden drop or low flame" in the *Troubleshooting Section*.

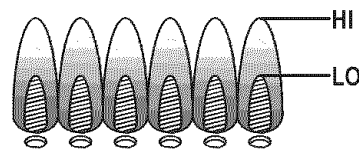

### Hose Check

- Before each use, check to see if hoses are cut, worn or kinked. Replace damaged hoses before using grill. Use only valve/hose/regulator specified in the Parts List.

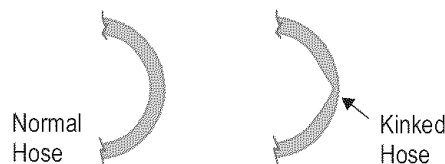



## Turning Grill Off

- Turn all knobs to **OFF** position. Turn LP tank off by turning OPD hand wheel clockwise to a full stop.

## Ignitor Check

- **Turn gas off at LP tank.** Press and hold ignitor button. "Click" should be heard and spark seen each time between collector box or burner and electrodes. See "Troubleshooting" if no click or spark.

## Valve Check

- **Important: Make sure gas is off at LP tank before checking valves.** Knobs lock in **OFF** position. To check valves, first push in knobs and release, knobs should spring back. If knobs do not spring back, replace valve assembly before using grill. Turn knobs to **LO** position then turn back to **OFF** position. Valves should turn smoothly.

## General Grill Cleaning

- Keep the outside of your grill looking new by cleaning it once a month with warm soap and water or a non-abrasive cleaner. If you don't have a grill cover, wipe off dust and grime before starting your grill.
- Coating the cooking grids with spray-on cooking oil will keep the food from sticking and make clean up easier. After cooking, scrape the grates with a long handled, brass wire bristle brush.
- Check inside the grill bottom for grease build up and clean often, especially after cooking fatty meat.
- Do not mistake brown or black accumulation of grease and smoke for paint. Apply a strong solution of detergent and water or use a grill cleaner with scrub brush on insides of grill lid and bottom. Rinse and allow to completely air dry. **Do not apply a caustic grill/oven cleaner to painted surfaces.**
- **Plated wire grates:** Wash grates with concentrated grill cleaner or use soap and water solution. Dry thoroughly and store indoors between cookouts.
- **Plastic parts:** Wash with warm soapy water and wipe dry.
  - ▲ Do not use citrisol, abrasive cleaners, degreasers or a concentrated grill cleaner on plastic parts. Damage to and failure of parts can result.
- **Porcelain grates:** Because of glass-like composition, most residue can be wiped away with baking soda/water solution or specially formulated cleaner. Use non-abrasive scouring powder for stubborn stains.



## SPIDER ALERT!

SPIDER AND WEBS  
INSIDE BURNER TUBE

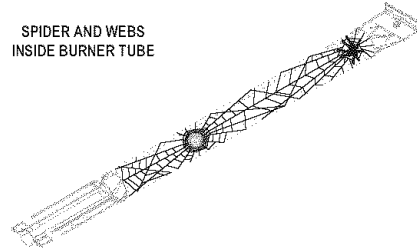

*If you notice that your grill is getting hard to light or that the flame isn't as strong as it should be, take the time to check and clean the burner's.*

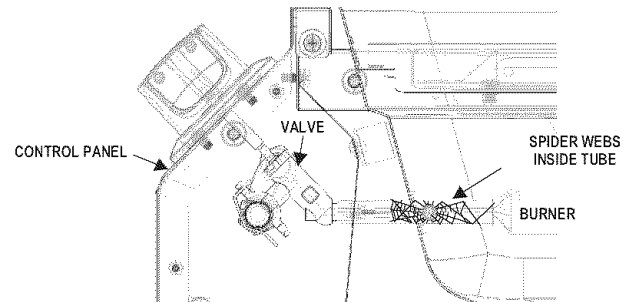

In some areas of the country, spiders or small insects have been known to create "flashback" problems. The spiders spin webs, build nests and lay eggs in the grill's burner tube(s) obstructing the flow of gas to the burner. The backed-up gas can ignite in the tube behind the control panel. This is known as a flashback and it can damage your grill and even cause injury.

To prevent flashbacks and ensure good performance the burner assembly should be removed from the grill and cleaned before use whenever the grill has been idle for an extended period.

## Cleaning the Burner Assembly

Follow these instructions to clean and/or replace parts of burner assembly or if you have trouble igniting grill.

1. Turn gas off at control knobs and LP cylinder.
2. Remove cooking grates and heat tents.
3. Remove screws and flame carryover tubes from rear of burners.
4. Remove screw and washers to disengage burner from bracket on firebox.
5. Remove screws to detach electrode from burner. Electrode should remain in firebox.
6. Carefully lift each burner up and away from valve openings.

We suggest three ways to clean the burner tubes. Use the one easiest for you.

- (A) Bend a stiff wire (a light weight coat hanger works well) into a small hook. Run the hook through each burner tube several times.



- (B) Use a narrow bottle brush with a flexible handle (do not use a brass wire brush), run the brush through each burner tube several times.

- (C) **Wear eye protection:** Use an air hose to force air into the burner tube and out the burner ports. Check each port to make sure air comes out each hole.

7. Wire brush entire outer surface of burner to remove food residue and dirt.
8. Clean any blocked ports with a stiff wire such as an open paper clip.
9. Check burner for damage, due to normal wear and corrosion some holes may become enlarged. If any large cracks or holes are found replace burner.

**VERY IMPORTANT: Burner tubes must re-engage valve openings. See illustrations at right.**

10. Attach electrode to burner.
11. Carefully replace burners.
12. Attach burners to brackets on firebox.
13. Reposition flame carryover tubes and attach to burners. Replace heat tents and cooking grates.

Correct  
burner-to-valve  
engagement

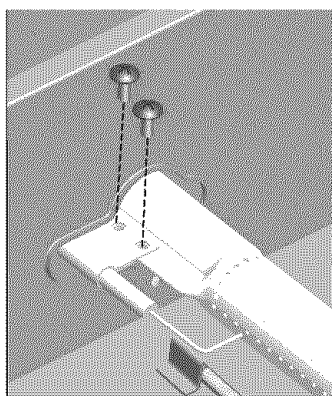
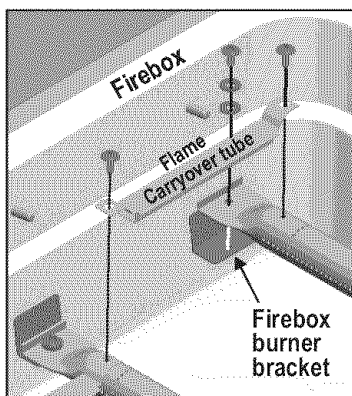
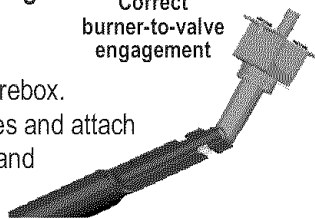

## Storing Your Grill

- Clean cooking grates.
- Store in dry location.
- When LP tank is connected to grill, store outdoors in well-ventilated space and out of reach of children.
- Cover grill if stored outdoors.
- Store grill indoors ONLY if LP tank is turned off and disconnected, removed from grill and stored outdoors.
- When removing grill from storage follow "Cleaning Burner Assembly" instructions before starting grill.

## Food Safety

Food safety is a very important part of enjoying the outdoor cooking experience. To keep food safe from harmful bacteria, follow these four basic steps:

**Clean:** Wash hands, utensils, and surfaces with hot soapy water before and after handling raw meat and poultry.

**Separate:** Separate raw meats and poultry from ready-to-eat foods to avoid cross contamination. Use a clean platter and utensils when removing cooked foods.

**Cook:** Cook meat and poultry thoroughly to kill bacteria. Use a thermometer to ensure proper internal food temperatures.

**Chill:** Refrigerate prepared foods and leftovers promptly.

**For more information call: USDA Meat and Poultry Hotline at 1-800-535-4555 (In Washington, DC (202) 720-3333, 10:00 am-4:00 pm EST).**

## How To Tell If Meat Is Grilled Thoroughly

- Meat and poultry cooked on a grill often browns very fast on the outside. Use a meat thermometer to be sure food has reached a safe internal temperature, and cut into food to check for visual signs of doneness.
- Whole poultry should reach 180° F; breasts, 170° F. Juices should run clear and flesh should not be pink.
- Hamburgers made of any ground meat or poultry should reach 160° F, and be brown in the middle with no pink juices. Beef, veal and lamb steaks, roasts and chops can be cooked to 145° F. All cuts of pork should reach 160° F.
- NEVER partially grill meat or poultry and finish cooking later. Cook food completely to destroy harmful bacteria.
- When reheating takeout foods or fully cooked meats like hot dogs, grill to 165° F, or until steaming hot.

## Indirect Cooking

Poultry and large cuts of meat cook slowly to perfection on the grill by indirect heat. The heat from selected burners circulates gently throughout the grill, cooking meat or poultry without the touch of a direct flame. This method greatly reduces flare-ups when cooking extra fatty cuts because there is no direct flame to ignite the fats and juices that drip during cooking.

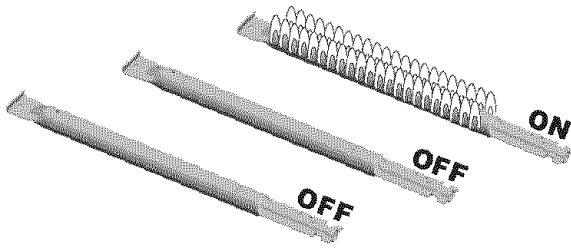

### 1 Burner Cooking

Cook with direct or indirect heat.  
Best for smaller meals or foods.  
Consumes less fuel.

## Indirect Cooking Instructions

- Always cook with the lid closed.
- Due to weather conditions, cooking times may vary. During cold and windy conditions the temperature setting may need to be increased to insure sufficient cooking temperatures

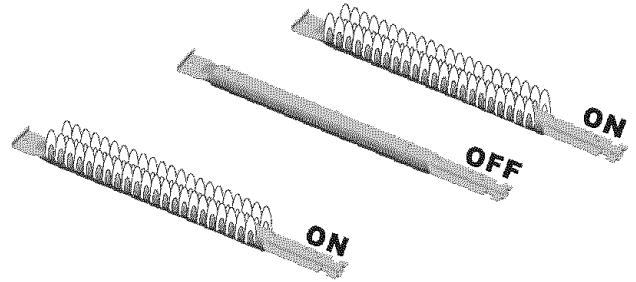

### 2 Burner Cooking

Great indirect cooking on low.  
Produces slow, even heating.  
Ideal for slow roasting and baking.

## PARTS LIST – Model No. 415.16117

<u>Key</u>	<u>Qty</u>	<u>Description</u>	<u>Part #</u>	<u>Key</u>	<u>Qty</u>	<u>Description</u>	<u>Part #</u>
1	1	Right Leg Assembly	80009040	30	1	Logo Plate	80009024
2	2	Leg Extenders	80008596	31	12	1/4-20x1/2" Screws	HMSO2520050CPNBZC
3	1	Match Lighter w/Chain	80009031	32	1	Right Side Shelf	80009033
4	1	Bottom Shelf	80009035	33	1	Right Fascia	80009048
5	1	Tank Thumbscrew	80006484	34	1	Sideburner Shelf	80009034
6	1	Tank Exclusion Wire	80008616	35	16	10-24X1/2" Screws	HMS01924050CPNSTBZ
7	4	1/4-20x1-1/2" Screws	HMS02520150CTHBZC	36	1	Sideburner Lid	80009042
8	4	7mm Fiber Washers	HFWM7PRSTSS	37	1	Sideburner Handle	80009043
9	4	7mm Lock Washers	HSWM7RHSPSS	38	8	5mm Fiber Washers	HFWM51D9DFB
10	16	1/4-20 Flange Nuts	HFNO2520MHBZC	39	4	#8-32 Flange Nuts	HFNO1632MHBZ
11	1	Left Leg Assembly	80009041	40	4	#8-32X3/8" Machine Screw	HMS01632038PPNBZC
12	2	Front Panels	80009038	41	1	Sideburner	80009044
13	10	#8x1/2" Self-Tap Screws	HABO16012CPNBZC	42	1	Sideburner Electrode	80009046
14	2	Wheels	80000627	43	1	Sideburner Grate	80003591
15	1	Axle Rod	80009036	44	1	Left Fascia	80009049
16	1	Flat Washer	80008091	45	1	Sideburner Griddle	80003592
17	1	Hitch Pins	80003610	46	2	Hinge Assemblies	80009045
18	1	Firebox	80009022	47	3	Heat Tent	80008530
19	1	Control Panel	80009058	48	1	Cooking Grate (set of 3)	80008531
20	1	Valve/Hose/Regulator	80009039	49	1	Swing Away	80008532
21	1	Ignitor Module	80009032	50	1	Grease Cup Clip	80000271
22	4	Bezels	80009030	51	1	Grease Cup	80000270
23	4	Knobs	80009030				
24	3	Burners	80009027				
25	1	Electrode	80009029				
26	2	Carry-Over Tubes	80009028				
27	1	Lid	80009023				
28	1	Handle	80009026				
29	1	Temperature Gauge	80009025				



# ASSEMBLY – Model No. 415.16117

1

## Tank Exclusion Wire

- Place legs as shown (A). Left leg assembly has large holes on ends of legs. Hook tank exclusion wire into right and left leg assemblies (B).

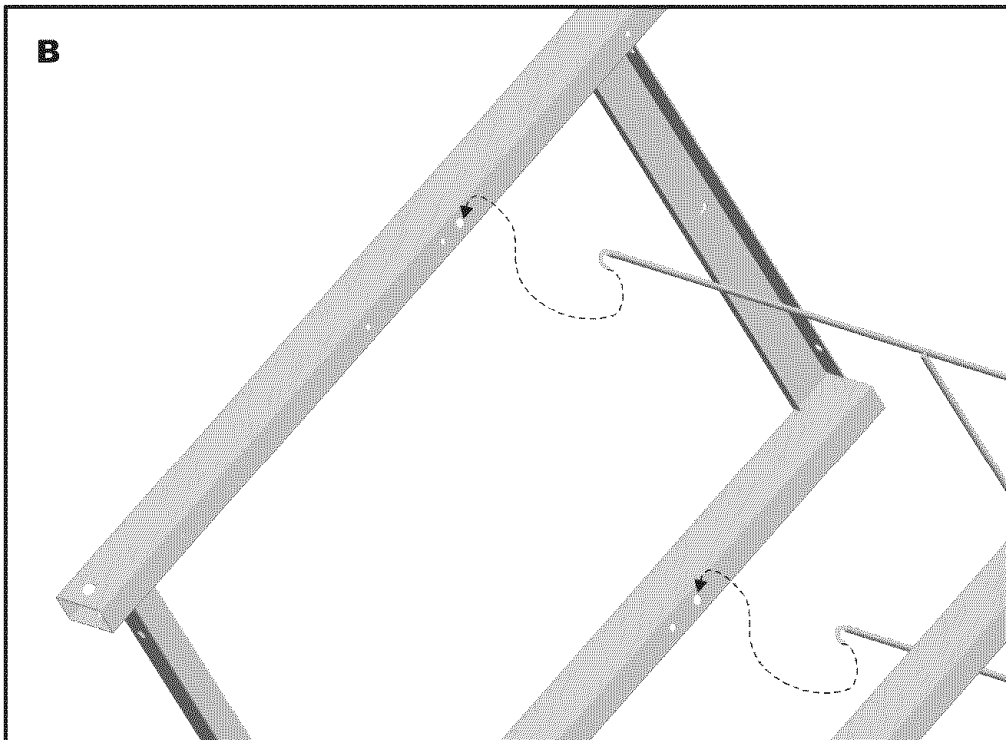
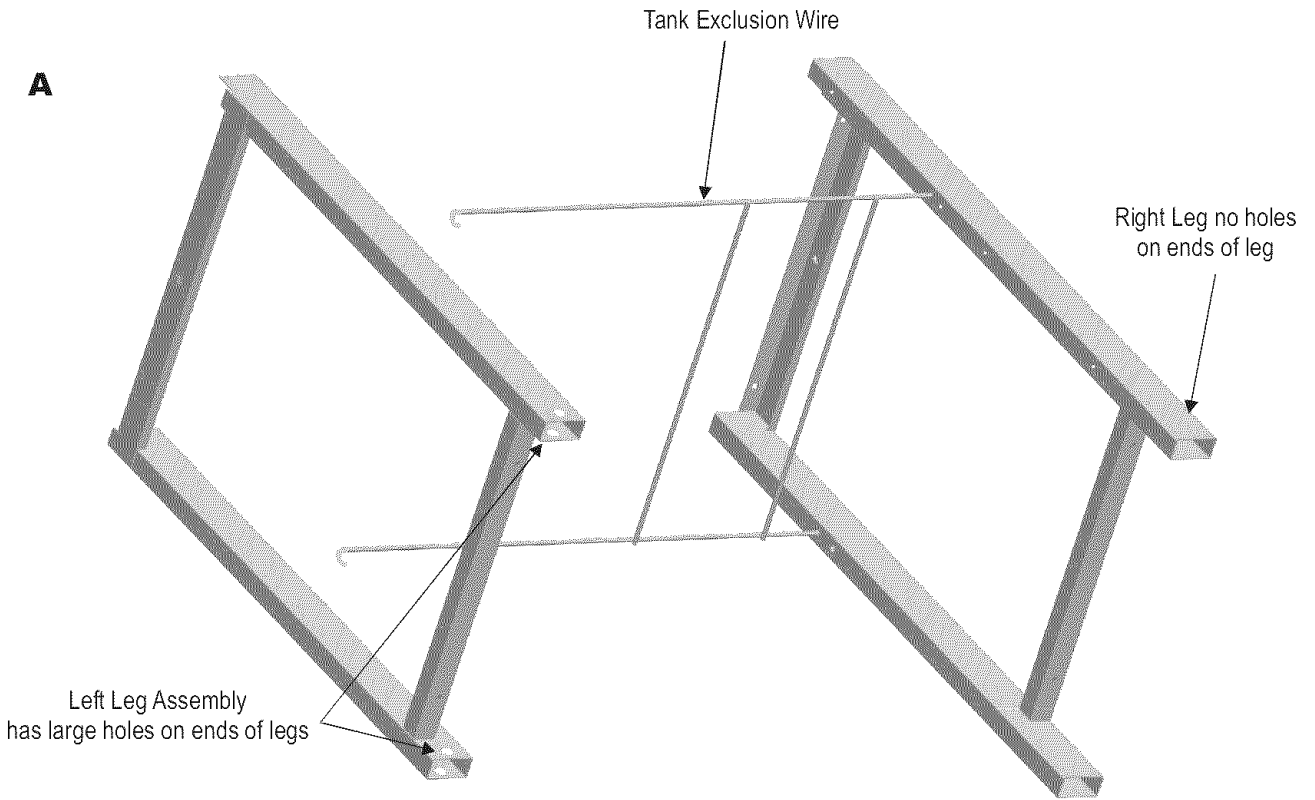

**2**

**Bottom Shelf to Legs**

□ Attach bottom shelf to right and left leg assemblies with (4) 1/4-20x1-1/2" screws and 1/4-20 flange nuts.

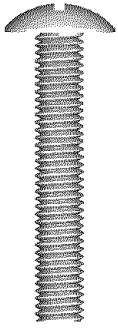

7  
Qty: 4

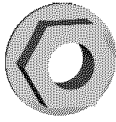

10  
Qty: 4

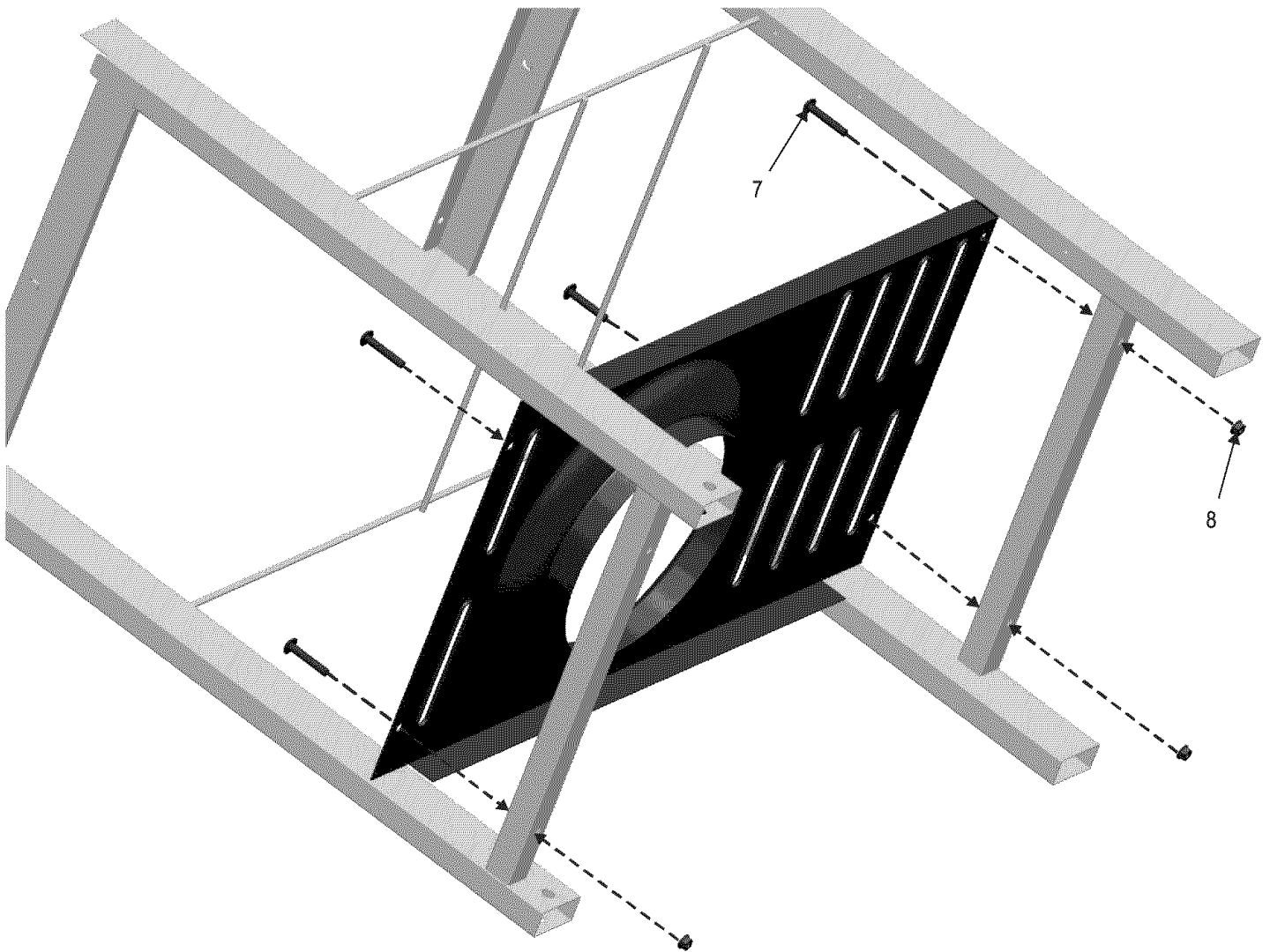

# 3

## Front Panels

- Stand cart upright.
- Attach one front panel to lower half of cart with (4) #8x1/2" self-tap screws.
- Slide slot in other panel onto tank exclusion wire and attach to upper half of cart with (4) #8x1/2" self-tap screws.

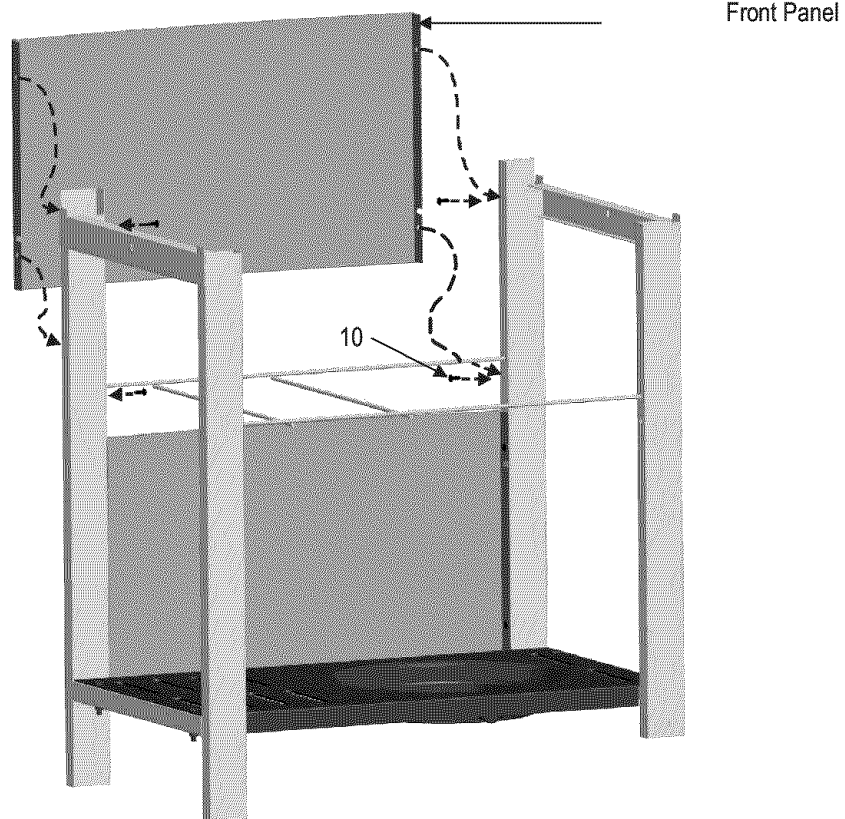
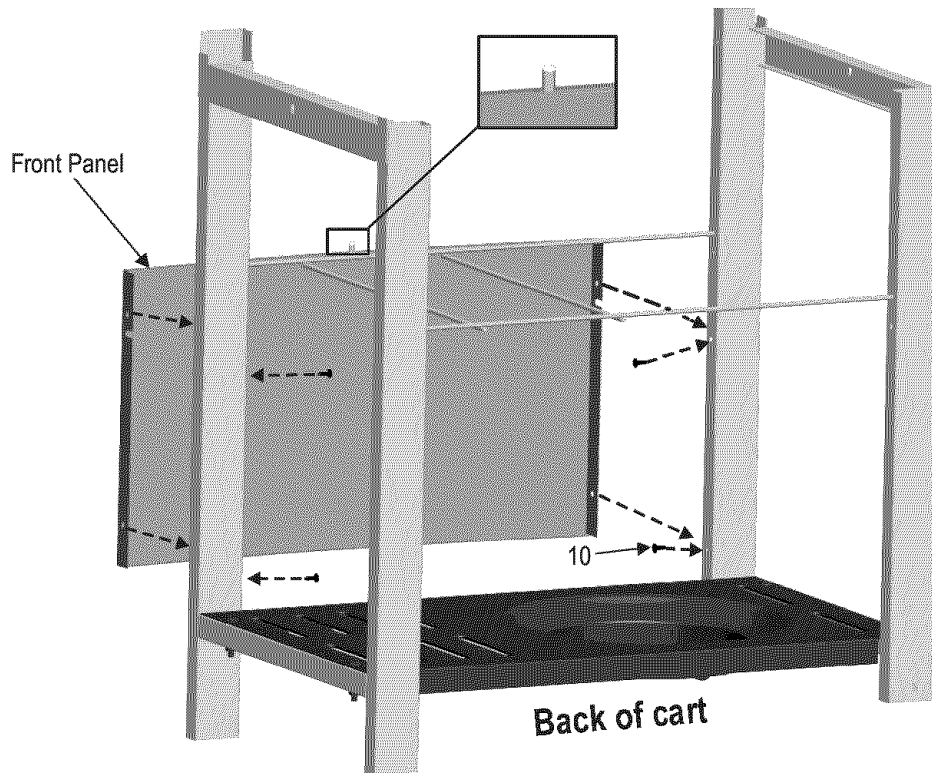



# 4

## Wheels and Leg Extenders to Cart

- ☐ Turn assembly upside down.
- ☐ Insert axle rod into wheel, legs and other wheel. Attach with a flat washer and hitch pin.
- ☐ Push leg extenders into right legs.

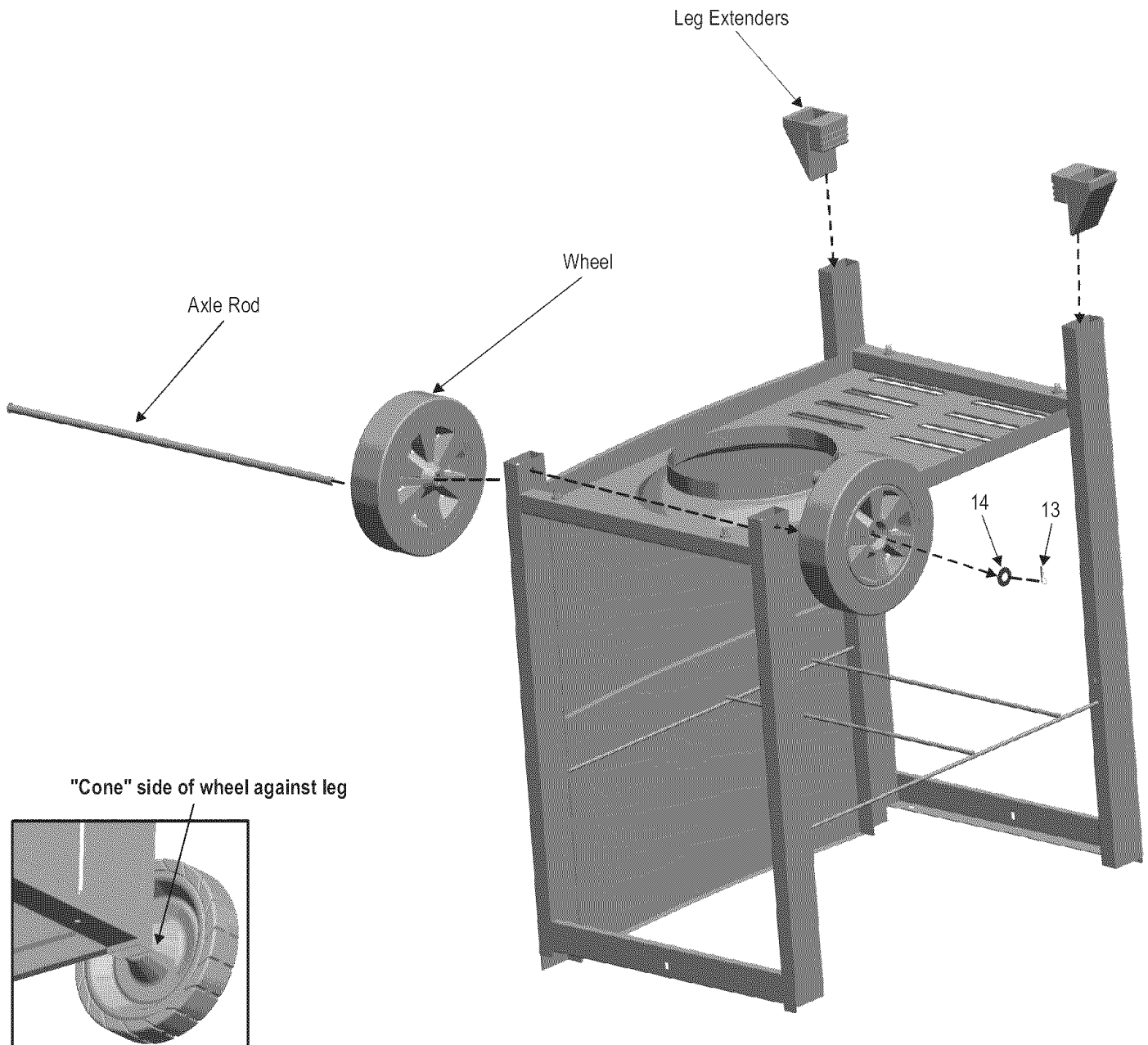
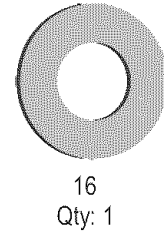
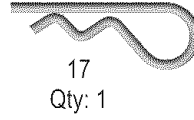

"Cone" side of wheel against leg

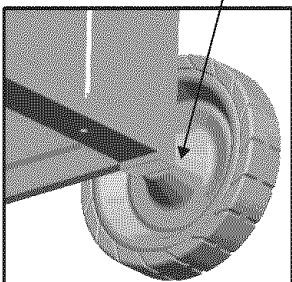

# 5

## Grill Head to Cart

- Stand cart upright.
- This step requires two people to lift and position grill head onto cart.
- Carefully lower the grill head onto the cart. Make sure the regulator hose is hanging outside the cart. Attach with 1/4-20x1/2" screws and 7mm lock washers.

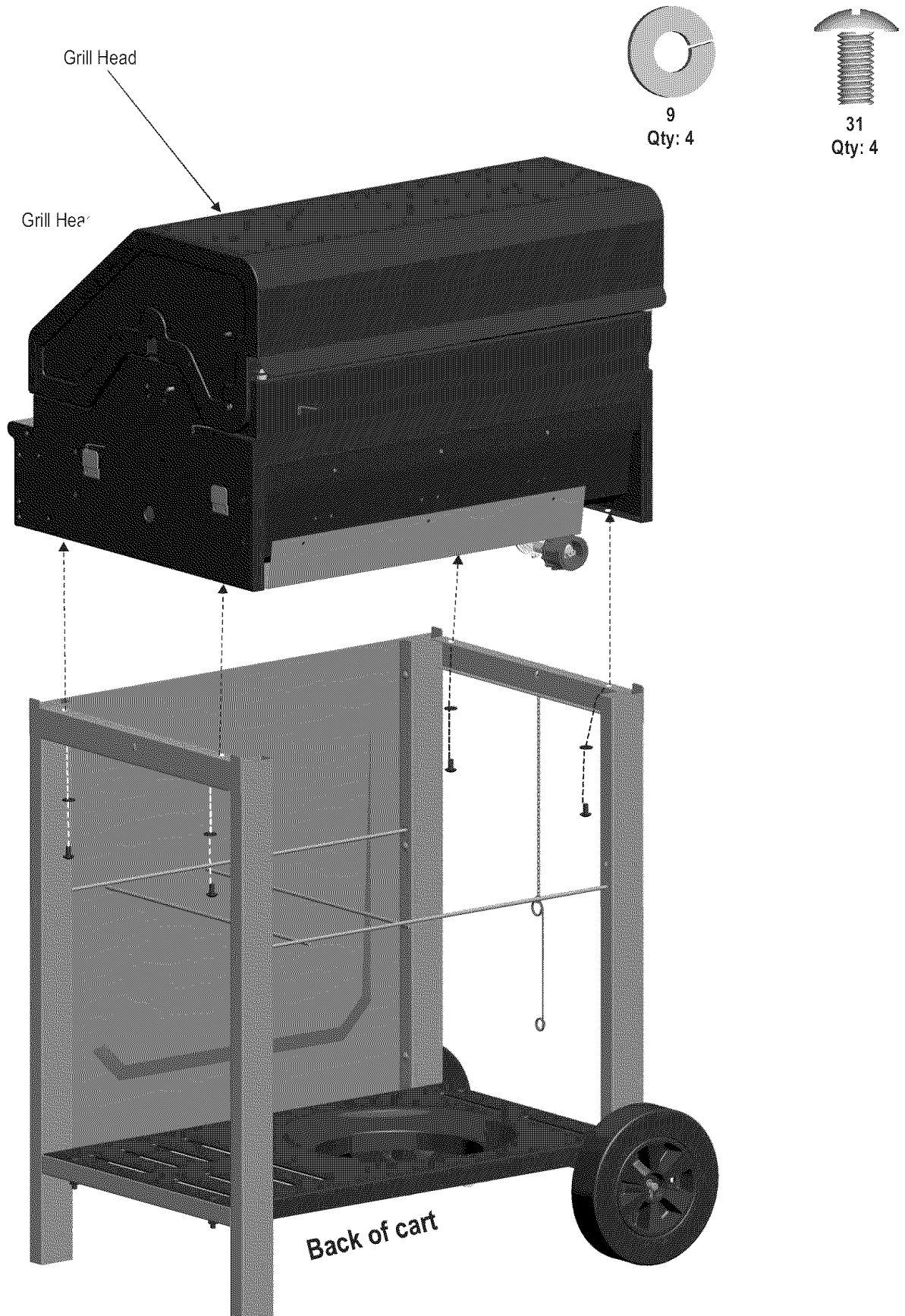

# 6

## Right Side Shelf

- Hook side wall of shelf over support brackets on side of firebox (A).
- Inside firebox insert fiber washers and 1/4-20x1/2" screws as shown (B).
- Attach shelf with flange nuts (C).

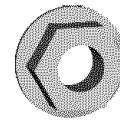

10  
Qty: 4

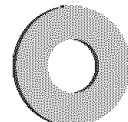

8  
Qty: 4

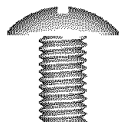

31  
Qty: 4

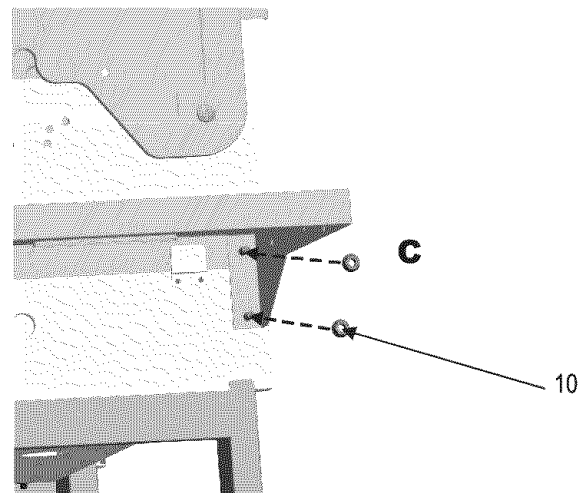
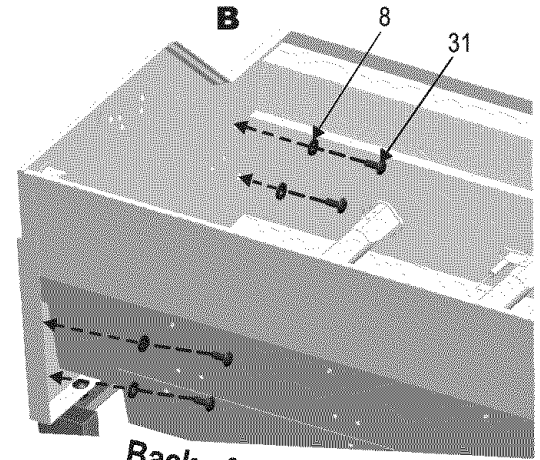
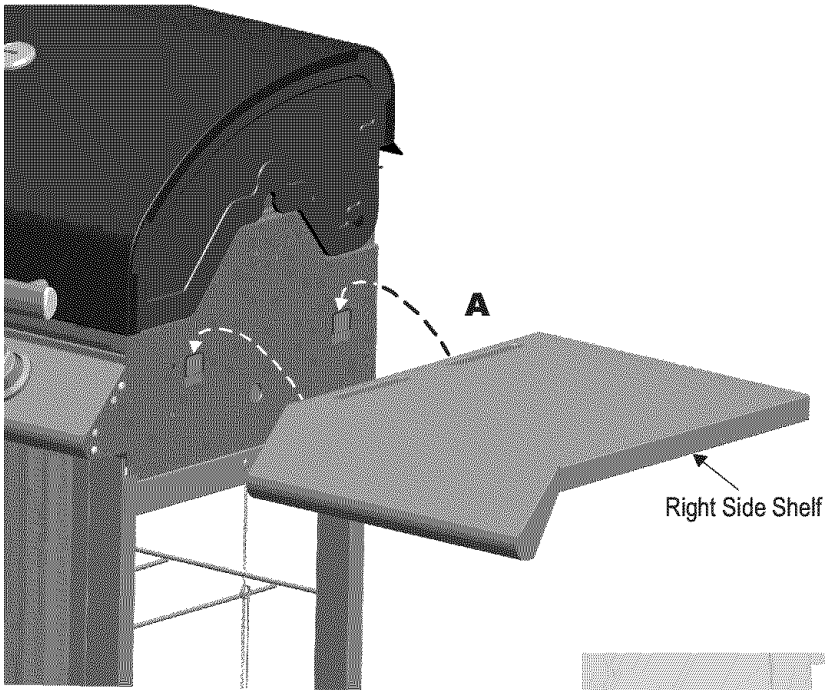

# 7

## Fascia Right Side Shelf

- Attach fascia to firebox with (1) #8x3/8" self-tap screw.



40  
Qty: 1

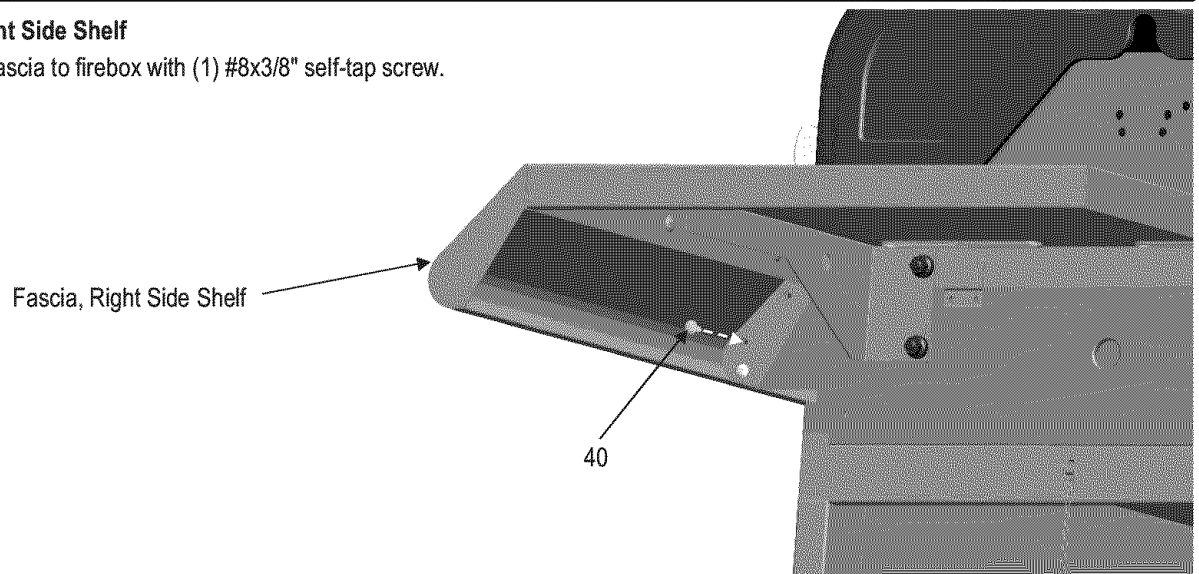

# 8

## Sideburner Shelf and Left Fascia

- Hook side wall of sideburner shelf over support brackets on side of firebox (A).
- Inside firebox insert fiber washers and 1/4-20x1/2" screws as shown (B).
- Attach sideburner shelf with flange nuts (C).

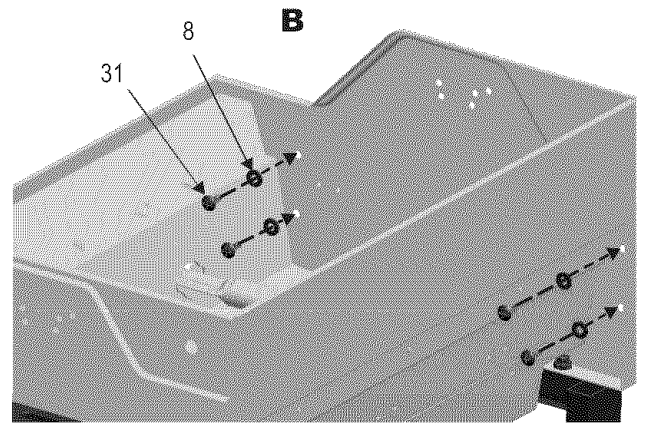
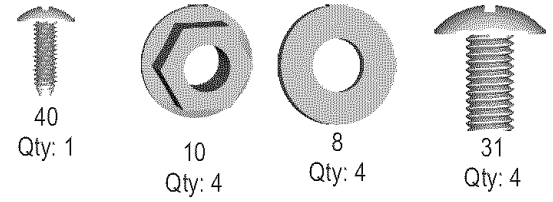
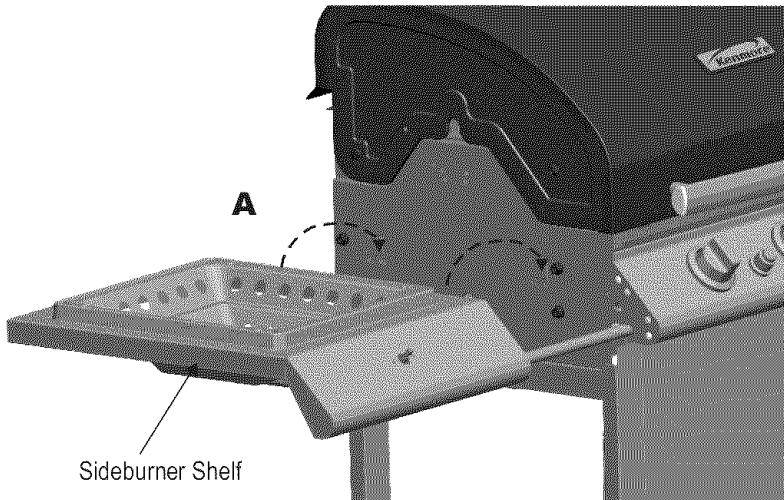

Back of cart

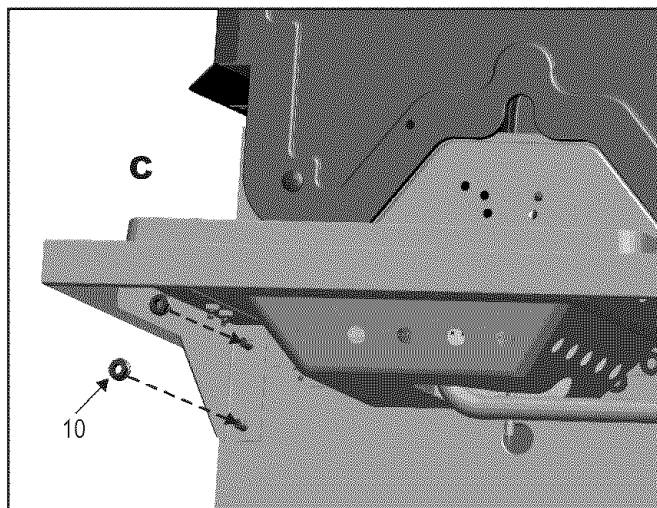

# 9

## Sideburner Bezel, Sideburner, Sideburner Knob and Ignitor Wire.

- ❑ Attach fascia to firebox with #8x3/8" self-tap screw (A).
- ❑ Remove screws and washers from sideburner valve. Attach sideburner bezel and valve with washers and screws (B).
- ❑ Place sideburner into shelf (C). Make sure valve is inside sideburner tube. Attach sideburner with two screws and washers.
- ❑ Press sideburner control knob onto valve stem (D).
- ❑ Under sideburner shelf, attach sideburner ignitor wire to electrode (E).

Correctly assembled burner-to-valve engagement

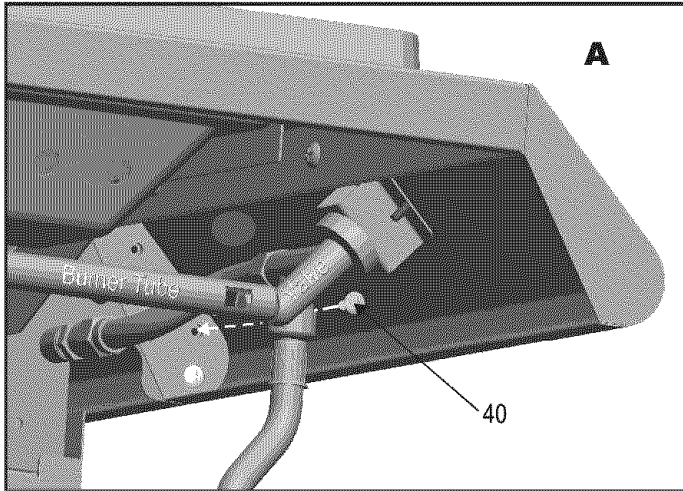

Looking underneath sideburner assembly

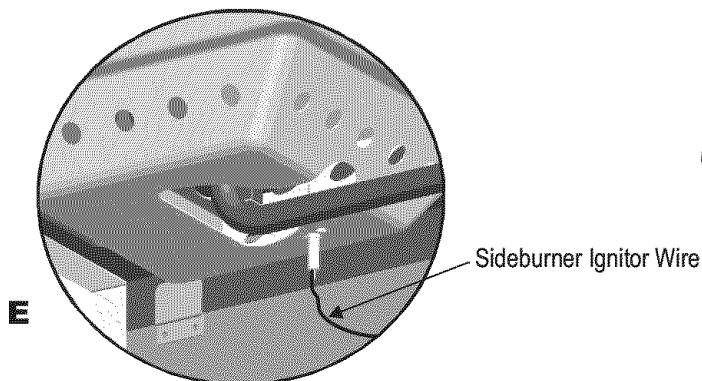
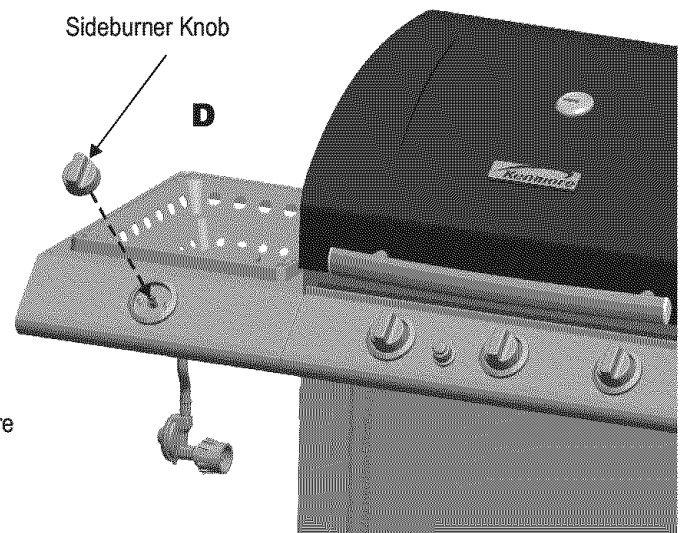
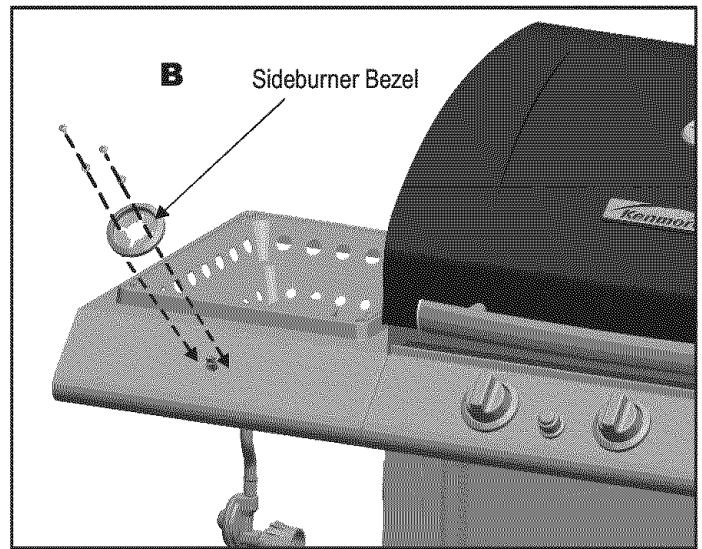
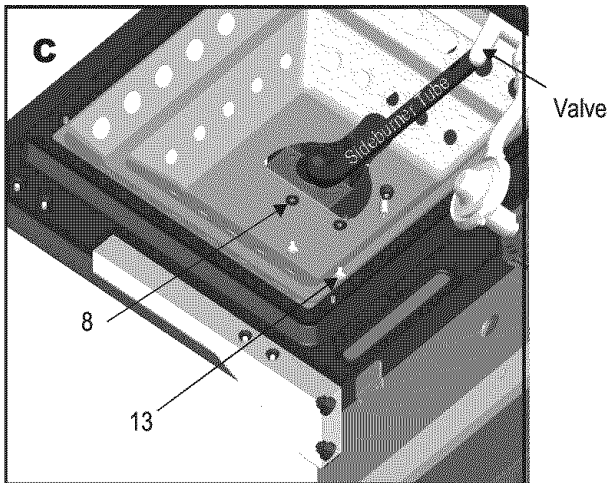

# 10

## Sideburner Lid

- Attach sideburner handle to lid with (2) 1/4-20x1/2" screws (A).
- Secure hinges to sideburner lid with (4) #10-24x1/2" screws and flange nuts (B).
- Place sideburner lid onto sideburner body. Attach with (4) #10-24x1/2" screws and flange nuts(C).

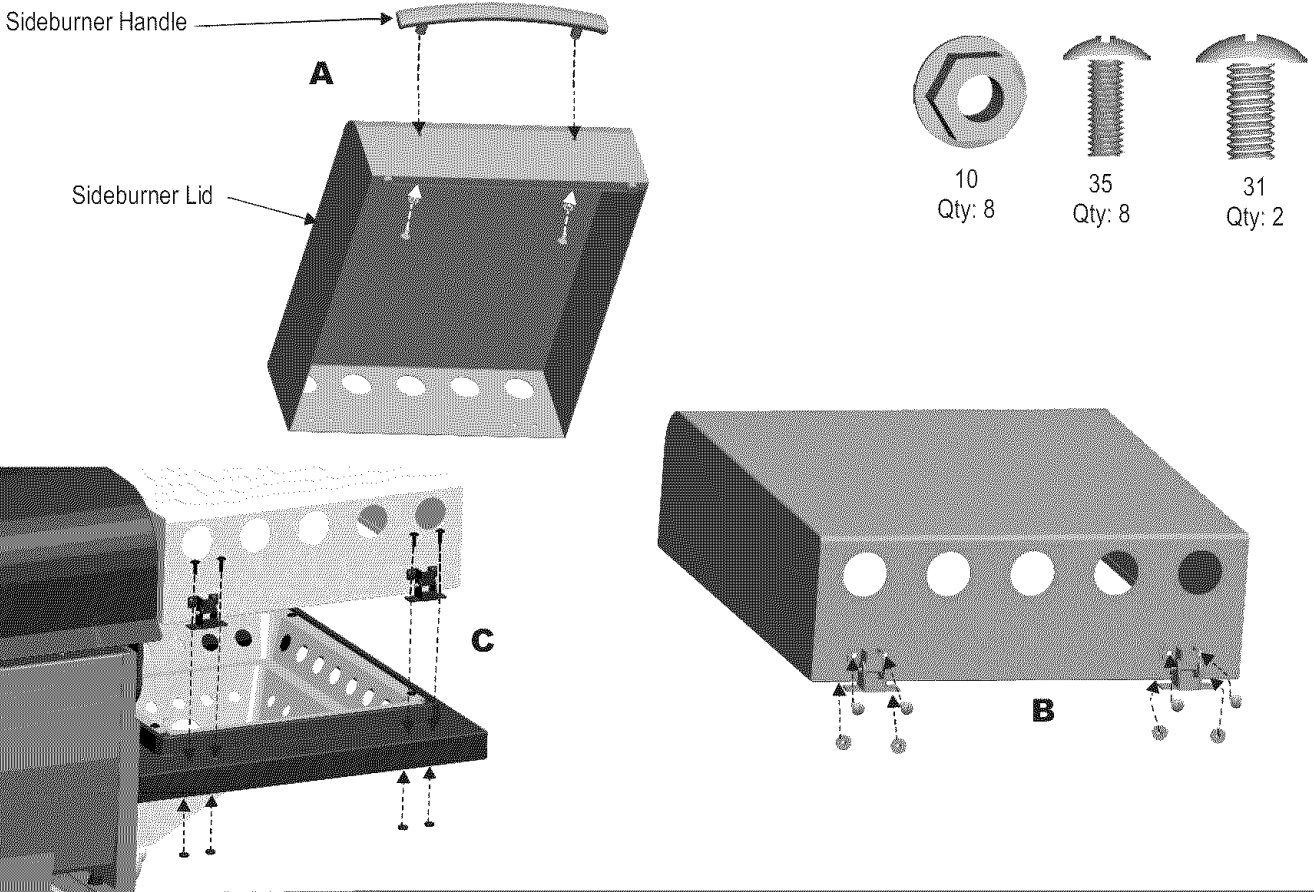

# 11

## Sideburner Grate or Griddle

- Place sideburner grate or griddle onto sideburner body.

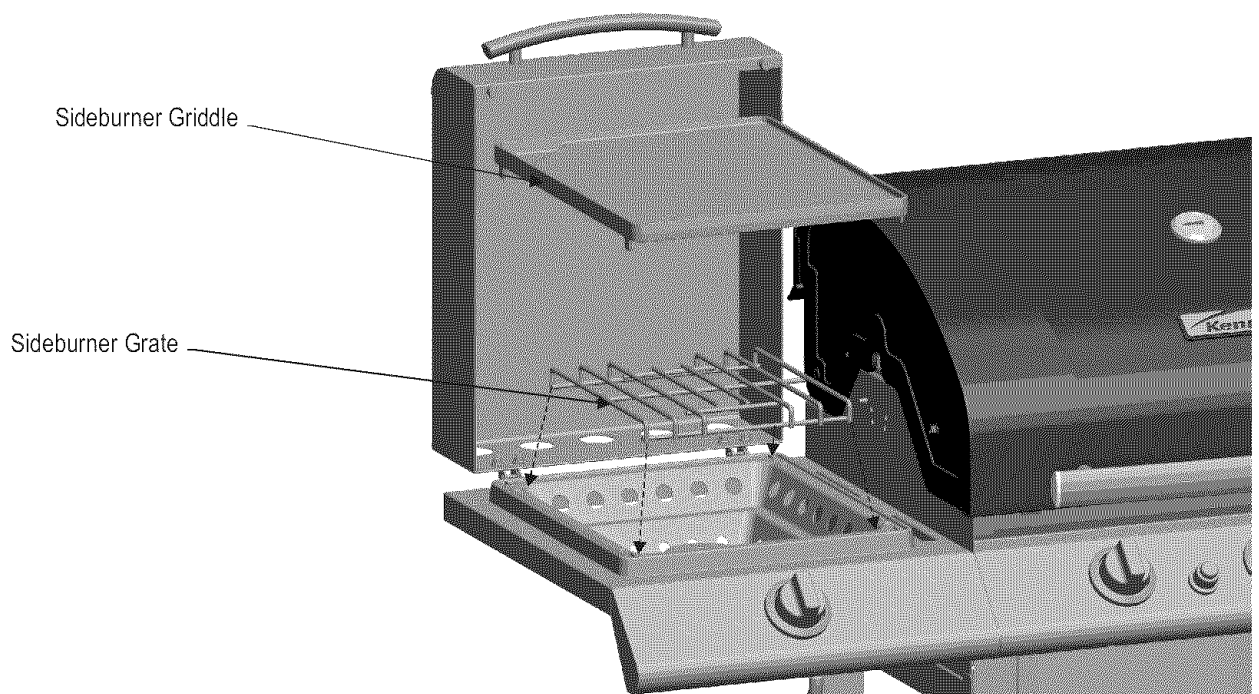

**12****Heat Tents**

- Place heat tents over burners by inserting tabs into slots in front of firebox. Opposite ends of heat tents rest on pins in back of firebox.

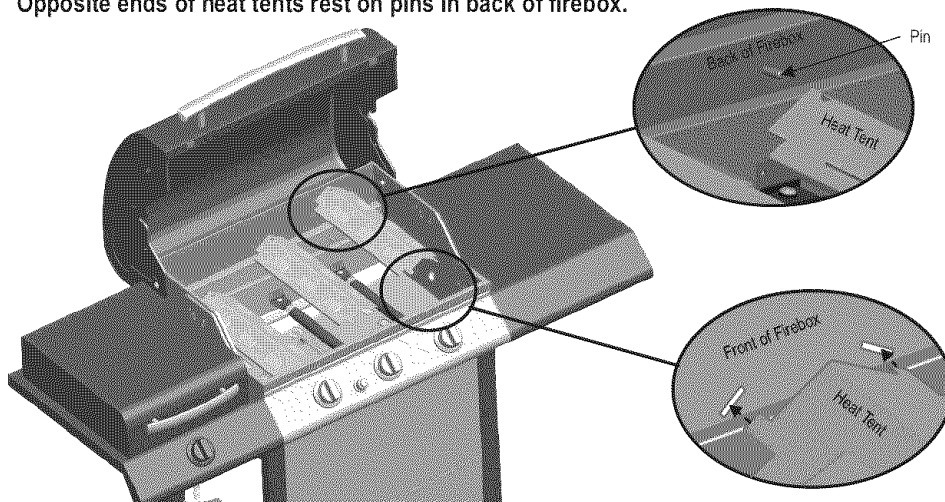
**13****Cooking Grate**

- Place cooking grates onto grate rests.

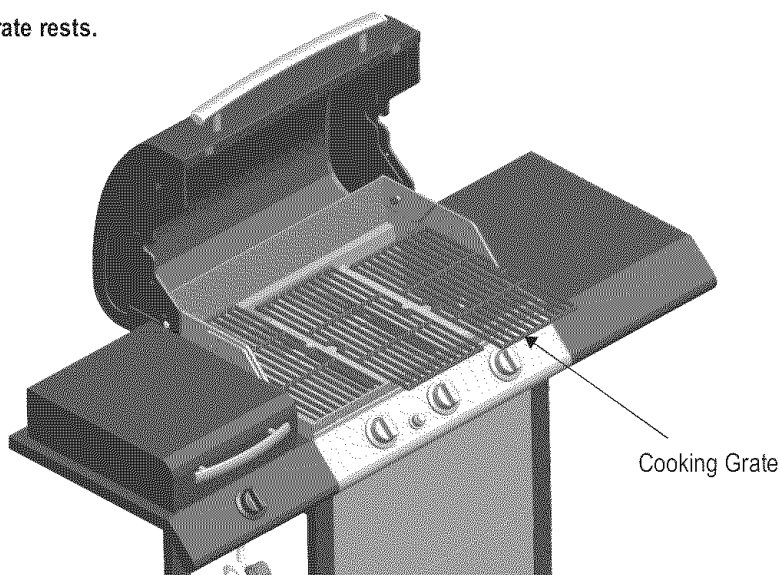
**14****Swing Away**

- Insert ends of Swing Away pivot wire into holes in sides of grill lid. Insert ends of Swing Away leg wire into holes in sides of firebox. NOTE: Pivot and leg wires, running side-to-side, should be under wires running front-to-back. If pivot and leg wires are on top, Swing Away is installed upside-down.
- Unscrew ignitor cap and place AA battery into ignitor slot with positive end (+) facing outward. Screw ignitor cap onto ignitor.

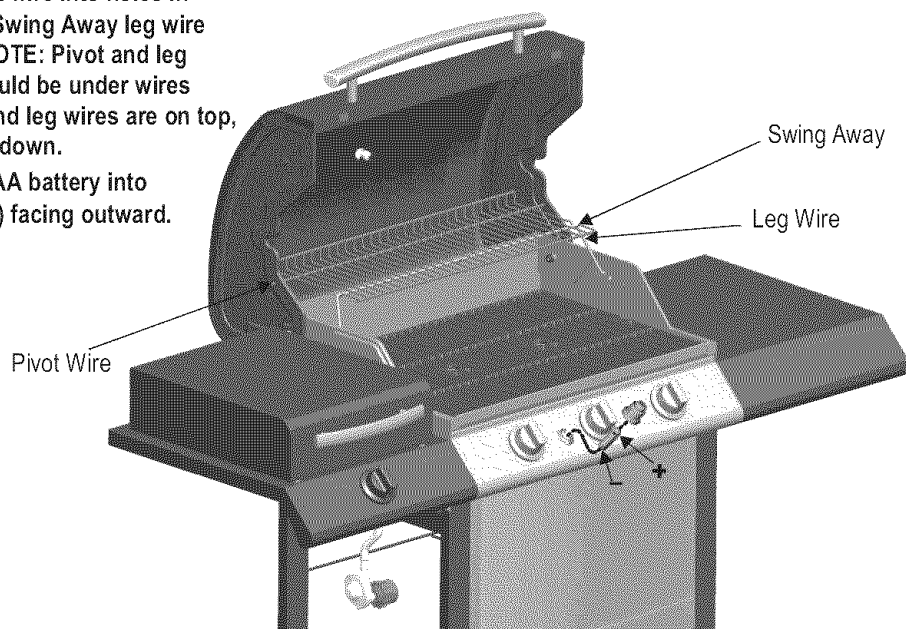

# 15

## Grease Cup Clip and Grease Cup

- Hang grease cup clip from bottom of firebox and place grease cup into grease clip.

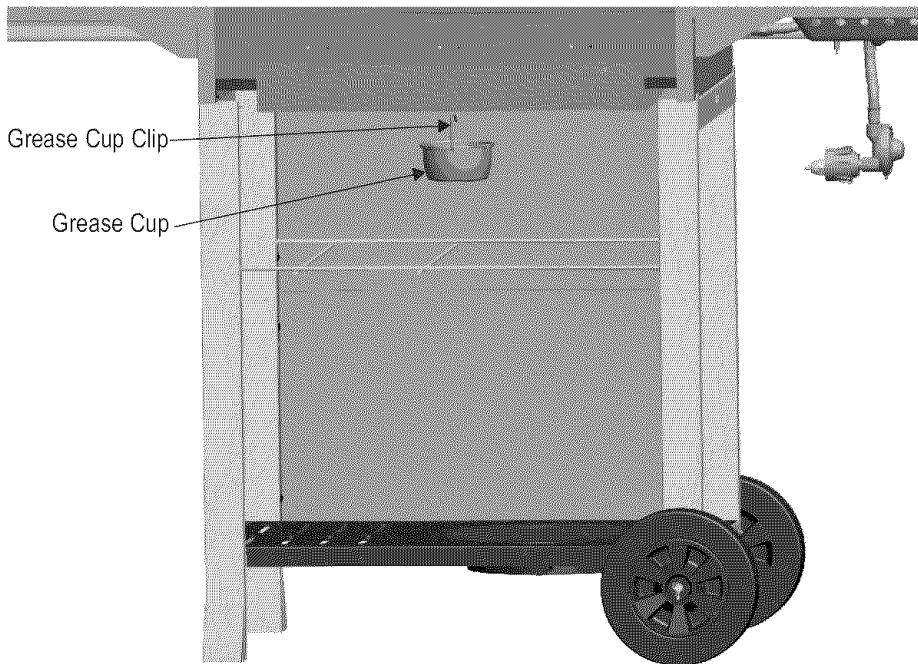

	<b>CAUTION</b>	
Failure to install grease cup clip and cup will cause hot grease to drip from bottom of grill with risk of fire or property damage.		

# 16

## LP Tank

- LP tank is sold separately. Use only with an OPD (over-fill protection device) equipped LP tank. Fill and leak check before attaching to grill and regulator.
- Place LP tank into hole in bottom shelf with tank collar opening facing to side as shown. Finger tighten tank thumbscrew to hold LP tank securely in place.

See Use and Care section to correctly Leak Test and perform the Burner Flame Check.

	<b>CAUTION</b>	
• Failure to install tank correctly may allow gas hose to be damaged in operation, resulting in the risk of fire.		

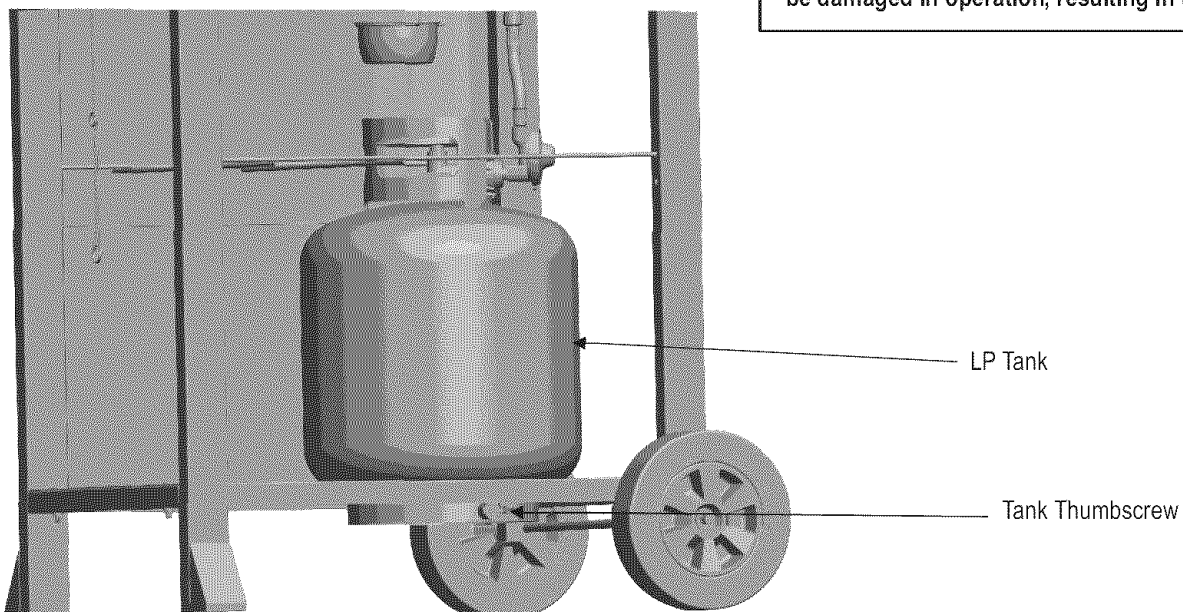



**Troubleshooting - Call 1-800-4-MY-HOME for assistance if required.**

**EMERGENCIES: If a gas leak cannot be stopped, or a fire occurs due to gas leakage, call the fire department.**

<b>Emergencies</b>	<b>Possible Cause</b>	<b>Prevention/Solution</b>
Gas leaking from cracked/cut/burned hose.	<ul style="list-style-type: none"> <li>Damaged hose.</li> </ul>	<ul style="list-style-type: none"> <li>Turn off gas at LP tank. If hose is cut or cracked, replace valve/hose/regulator. See LP Tank Leak Test and Connecting Regulator To The LP Tank.</li> </ul>
Gas leaking from LP tank.	<ul style="list-style-type: none"> <li>Mechanical failure due to rusting or mishandling.</li> </ul>	<ul style="list-style-type: none"> <li>Turn off LP tank valve.</li> </ul>
Gas leaking from LP tank valve.	<ul style="list-style-type: none"> <li>Failure of tank valve from mishandling or mechanical failure.</li> </ul>	<ul style="list-style-type: none"> <li>Turn off LP tank valve. Return LP tank to gas supplier.</li> </ul>
Gas leaking between LP tank and regulator connection.	<ul style="list-style-type: none"> <li>Improper installation, connection not tight, failure of rubber seal.</li> </ul>	<ul style="list-style-type: none"> <li>Turn off LP tank valve. Remove regulator from cylinder and visually inspect rubber seal for damage. See LP Tank Leak Test and Connecting Regulator To The LP Tank.</li> </ul>
Fire coming through control panel.	<ul style="list-style-type: none"> <li>Fire in burner tube section of burner due to partial blockage.</li> </ul>	<ul style="list-style-type: none"> <li>Turn off control knobs and LP tank valve. Leave lid open to allow flames to die down. After fire is out and grill is cold, remove burner and inspect for spider nests or rust. See Natural Hazard and Cleaning The Burner Assembly pages.</li> </ul>
<b>Troubleshooting: Problem</b>	<b>Possible Cause</b>	<b>Prevention/Solution</b>
Grease fire or continuous excessive flames above cooking surface.	<ul style="list-style-type: none"> <li>Too much grease buildup in burner area.</li> </ul>	<ul style="list-style-type: none"> <li>Turn off LP tank valve. Leave lid open to allow flames to die down. After cooling, clean food particles and excess grease from inside firebox area, grease cup/pan/tray, and other surfaces.</li> </ul>
Burner(s) will not light using ignitor.	<p><b>GAS ISSUES:</b></p> <ul style="list-style-type: none"> <li>Trying to light wrong burner.</li> <li>Burner not engaged with control valve.</li> <li>Obstruction in burner.</li> <li>No gas flow.</li> <li>Vapor lock at coupling nut to LP tank.</li> <li>Coupling nut and LP tank valve not fully connected.</li> </ul>	<ul style="list-style-type: none"> <li>See instructions on control panel and section in the Use and Care.</li> <li>Make sure valves are positioned inside of burner tubes.</li> <li>Ensure burner tubes are not obstructed with spider webs or other matter. See cleaning section of Use and Care.</li> <li>Make sure LP tank is not empty. If LP tank is not empty, refer to "Sudden drop in gas flow."</li> <li>Turn off knobs and disconnect coupling nut from LP tank. Reconnect and retry.</li> <li>Turn the coupling nut approximately one-half to three-quarters additional turn until solid stop. Tighten by hand only - do not use tools.</li> </ul>
	<p><b>ELECTRICAL ISSUES:</b></p> <ul style="list-style-type: none"> <li>Electrode cracked or broken; "sparks at crack."</li> <li>Electrode tip not in proper position.</li> <li>Wire and/or electrode covered with cooking residue.</li> <li>Wires are loose or disconnected.</li> <li>Wires are shorting (sparking) between ignitor and electrode.</li> </ul>	<ul style="list-style-type: none"> <li>Replace electrode.</li> <li>Tip of electrode should be pointing toward port hole in burner. The distance should be 1/8" to 3/16". Adjust if necessary.</li> <li>Clean wire and/or electrode with rubbing alcohol and clean swab.</li> <li>Reconnect wires or replace electrode/wire assembly.</li> <li>Replace ignitor wire.</li> </ul>

*Continued on next page.*

## Troubleshooting (continued)

Problem	Possible Cause	Prevention/Solution
Burner(s) will not light using ignitor.	<ul style="list-style-type: none"> <li>• Push-button sticks at bottom..</li> <li>• Sparking between ignitor and electrode.</li> </ul>	<ul style="list-style-type: none"> <li>• Replace ignitor.</li> <li>• Inspect wire insulation and proper connection. Replace wires if insulation is broken.</li> </ul>
Burner(s) will not match light.	<ul style="list-style-type: none"> <li>• See “<b>GAS ISSUES:</b>” on previous page.</li> <li>• Improper method of match-lighting.</li> </ul>	<ul style="list-style-type: none"> <li>• See “Match-Lighting” section of Use and Care.</li> </ul>
Sudden drop in gas flow or low flame.	<ul style="list-style-type: none"> <li>• Out of gas.</li> <li>• Excess flow valve tripped.</li> <li>• Vapor lock at coupling nut/LP tank connection.</li> </ul>	<ul style="list-style-type: none"> <li>• Check for gas in LP tank.</li> <li>• Turn off knobs, wait 30 seconds and light grill. If flames are still low, turn off knobs and LP tank valve. Disconnect regulator. Reconnect regulator and leak-test. Turn on LP tank valve, wait 30 seconds and then light grill.</li> <li>• Turn off knobs and LP tank valve. Disconnect coupling nut from tank. Reconnect and retry.</li> </ul>
Flames blow out.	<ul style="list-style-type: none"> <li>• High or gusting winds.</li> <li>• Low on LP gas.</li> <li>• Excess flow valve tripped.</li> </ul>	<ul style="list-style-type: none"> <li>• Turn front of grill to face wind or increase flame height.</li> <li>• Refill LP tank.</li> <li>• Refer to “Sudden drop in gas flow” above.</li> </ul>
Flare-up.	<ul style="list-style-type: none"> <li>• Grease buildup.</li> <li>• Excessive fat in meat.</li> <li>• Excessive cooking temperature.</li> </ul>	<ul style="list-style-type: none"> <li>• Clean burners and inside of grill/firebox.</li> <li>• Trim fat from meat before grilling.</li> <li>• Adjust (lower) temperature accordingly.</li> </ul>
Persistent grease fire.	<ul style="list-style-type: none"> <li>• Grease trapped by food buildup around burner system.</li> </ul>	<ul style="list-style-type: none"> <li>• Turn knobs to OFF. Turn gas off at LP tank. Leave lid in position and let fire burn out. After grill cools, remove and clean all parts.</li> </ul>
Flashback... (fire in burner tube(s)).	<ul style="list-style-type: none"> <li>• Burner and/or burner tubes are blocked.</li> </ul>	<ul style="list-style-type: none"> <li>• Turn knobs to OFF. Clean burner and/or burner tubes. See burner cleaning section of Use and Care manual.</li> </ul>
Unable to fill LP tank.	<ul style="list-style-type: none"> <li>• Some dealers have older fill nozzles with worn threads.</li> </ul>	<ul style="list-style-type: none"> <li>• The worn nozzles don't have enough “bite” to engage the valve. Try a second LP dealer.</li> </ul>
One burner does not light from other burner(s).	<ul style="list-style-type: none"> <li>• Grease buildup or food particles in end(s) of carryover tube(s).</li> </ul>	<ul style="list-style-type: none"> <li>• Clean carry-over tube(s) with wire brush.</li> </ul>

## Troubleshooting - Electronic Ignition

Problem (Ignition)	Possible Cause	Check Procedure	Prevention/Solution
<p><b>SECTION I</b> No sparks appear at any electrodes when ignition button is pushed; no noise can be heard from spark module.</p>	<ul style="list-style-type: none"> <li>• Battery not installed properly.</li> <li>• Dead battery.</li> <li>• Button assembly not installed properly.</li> <li>• Faulty spark module.</li> </ul>	<ul style="list-style-type: none"> <li>• Check battery orientation.</li> <li>• Has battery been used previously?</li> <li>• Check to ensure button assembly is fully engaged. Button should travel up and down without binding.</li> <li>• If no sparks are generated with new battery and good wire connections, module is faulty.</li> </ul>	<ul style="list-style-type: none"> <li>• Install battery (make sure that “+” and “-” connectors are oriented correctly, with “+” end up and “-” end down.)</li> <li>• Replace battery with new AA-size alkaline battery.</li> <li>• Remove button cap assembly and reinstall, making sure it can be fully engaged.</li> <li>• Replace spark module assembly.</li> </ul>
<p><b>SECTION II</b> No sparks appear at any electrodes when ignition switch is pushed; noise can be heard from spark module.</p>	<ul style="list-style-type: none"> <li>• Output lead connections not connected.</li> <li>• Electrode tip not in proper position.</li> </ul>	<ul style="list-style-type: none"> <li>• Are output connections on and tight?</li> <li>• Are the electrode tips pointing in the right direction? Is the gap too big?</li> </ul>	<ul style="list-style-type: none"> <li>• Remove and reconnect all output connections at module and electrodes.</li> </ul> <p>Main Burners:</p> <ul style="list-style-type: none"> <li>• Tip of electrode should be pointing toward port hole in burner. The distance should be 1/8” to 3/16”.</li> </ul> <p>Adjust if necessary.</p> <p>Sideburner:</p> <ul style="list-style-type: none"> <li>• Tip of electrode should be pointing toward gas port opening on burner. The distance should be 1/8” to 3/16”. Adjust if necessary.</li> </ul>
<p><b>SECTION III</b> Sparks are present but not at all electrodes and/or not at full strength</p>	<ul style="list-style-type: none"> <li>• Output lead connections not connected.</li> <li>• Arcing to grill away from burner(s).</li> <li>• Weak battery.</li> <li>• Electrodes are wet.</li> <li>• Electrodes cracked or broken “sparks at crack”.</li> </ul>	<ul style="list-style-type: none"> <li>• Are output connections on and tight?</li> <li>• If possible, observe grill in dark location. Operate ignition system and look for arcing between output wires and grill frame.</li> <li>• All sparks present but weak or at slow rate.</li> <li>• Has moisture accumulated on electrode and/or in burner ports?</li> <li>• Inspect electrodes for cracks.</li> </ul>	<ul style="list-style-type: none"> <li>• Remove and reconnect all output connections at module and electrodes.</li> <li>• If sparks are observed other than from burner(s), wire insulation may be damaged. Replace wires.</li> <li>• Replace battery with a new AA-size alkaline battery.</li> <li>• Use paper towel to remove moisture.</li> <li>• Replace cracked or broken electrodes.</li> </ul>

# Get it fixed, at your home or ours!

## Your Home

For repair—in **your home**—of **all** major brand appliances, lawn and garden equipment, or heating and cooling systems, **no matter who made it, no matter who sold it!**

For the replacement parts, accessories and owner's manuals that you need to do-it-yourself.

For Sears professional installation of home appliances and items like garage door openers and water heaters.

**1-800-4-MY-HOME®** (1-800-469-4663)

Call anytime, day or night (U.S.A. and Canada)

[www.sears.com](http://www.sears.com)

[www.sears.ca](http://www.sears.ca)

## Our Home

For repair of carry-in items like vacuums, lawn equipment, and electronics, call or go on-line for the location of your nearest **Sears Parts & Repair Center.**

**1-800-488-1222**

Call anytime, day or night (U.S.A. only)

[www.sears.com](http://www.sears.com)

To purchase a protection agreement (U.S.A.) or maintenance agreement (Canada) on a product serviced by Sears:

**1-800-827-6655** (U.S.A.)

**1-800-361-6665** (Canada)

Para pedir servicio de reparación a domicilio, y para ordenar piezas:

**1-888-SU-HOGAR®**

(1-888-784-6427)

Au Canada pour service en français:

**1-800-LE-FOYER<sup>MC</sup>**

(1-800-533-6937)

[www.sears.ca](http://www.sears.ca)

The Sears logo is displayed in a large, stylized font with a swoosh underneath.

© Registered Trademark / <sup>TM</sup> Trademark / <sup>SM</sup> Service Mark of Sears Brands, LLC

© Marca Registrada / <sup>TM</sup> Marca de Fábrica / <sup>SM</sup> Marca de Servicio de Sears Brands, LLC

<sup>MC</sup> Marque de commerce / <sup>MD</sup> Marque déposée de Sears Brands, LLC

© Sears Brands, LLC