

Operator's manual

Z4218/968999281

Z4219/968999511

Z4824/968999512

Z5426/968999508

Please read the operator's manual carefully and make sure you understand the instructions before using the machine.

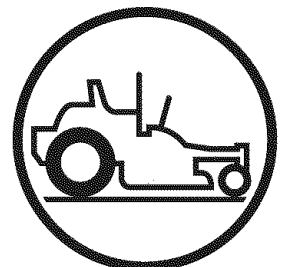

English

OPERATOR'S MANUAL

RIDER

Z SERIES

Contents

Contents	1	Moving by Hand	33
Introduction	3	Maintenance	34
Congratulations	3	Maintenance Schedule.....	34
General	3	Battery.....	36
Driving and Transport on Public Roads	3	Ignition System.....	37
Towing	3	Checking the Safety System	38
Operating	3	Checking the Engine's Cooling Air Intake	39
Good Service	4	Checking and Adjusting the Throttle Cable.....	39
Manufacturing Number	4	Replacing the Air Filter.....	40
Symbols and Decals	5	Replacing the Fuel Filter	41
Safety Instructions	7	Checking Tire Pressures.....	41
General Use.....	7	Checking the Parking Brake.....	41
Personal Safety Equipment	9	Checking the V-belts	42
Driving on Slopes.....	9	Deck belt	42
Children.....	10	EZT belt.....	44
Utility Box.....	10	Checking the Blades	45
Maintenance	11	Adjusting the Mower Deck	46
Transport.....	13	Cleaning and Washing	50
Customer responsibilities	14	Caster Wheels.....	50
Controls	16	Hardware.....	50
Control Locations	16	Lubrication	51
1. Motion Control Levers.....	17	Lubrication Schedule.....	51
2. Seat adjustment knobs	18	General	51
3. Fuses	18	Lubricating the Cables	52
4. By pass linkages	19	Lubricating in Accordance with the Lubrication	
5. Refueling.....	20	Schedule	52
6. Blade switch.....	20	Trouble Shooting Guide	56
7. Ignition Switch.....	21	Storage	59
8. Choke Control.....	21	Winter Storage	59
9. Throttle Control	21	Service	59
10. Hour Meter	22	Wiring diagram	60
11. Parking Brake	22	Technical Data	61
12. Cutting height pedal	23	Accessories.....	65
Accessories.....	23	Torque Specifications.....	65
Operation	24	Conformity Certificates	66
Training.....	24	USA requirements.....	66
Before Starting	25	Service Journal	67
Starting the Engine	25	Delivery Service	67
To start an engine with a weak battery	28	After the First 5-8 Hours.....	68
Running.....	29	25-Hour Service	69
Operating on hills.....	30	50-Hour Service	70
Mowing Tips.....	31	100-Hour Service	71
Stopping the Engine.....	32	300-Hour Service	72
		At Least Once Each Year.....	73



WARNING!

Failure to follow cautious operating practices can result in serious injury to the operator or other persons. The owner must understand these instructions, and must allow only trained persons who understand these instructions to operate the mower. Each person operating the mower must be of sound mind and body and must not be under the influence of any mind altering substance.



WARNING!

Engine exhaust, some of its constituents, and certain vehicle components contain or emit chemicals known to the State of California to cause cancer and birth defects or other reproductive harm.



WARNING!

Battery posts, terminals and related accessories contain lead and lead compounds, chemicals known to the State of California to cause cancer and birth defects or other reproductive harm. Wash hands after handling.

INTRODUCTION

Introduction

Congratulations

Thank you for purchasing a Husqvarna ride-on mower. This machine is built for the greatest efficiency and rapid mowing primarily of large areas. Controls in one place and a hydrostatic transmission regulated by steering controls also contribute to the machine's performance.

This manual is a valuable document. Following the instructions (use, service, maintenance, etc.) by all who operate this machine can considerably increase the lifespan of your machine and even increase its resale value. It is also very important to follow the instructions for the safety of you and others.

If you sell your machine, be sure to give the operator's manual to the new owner.

The final chapter of this operator's manual comprises a Service Journal. Ensure that service and repair work is documented. A well kept service journal reduces service costs for the season-based maintenance and affects the machine's resale value. Take the operator's manual along when the machine is left to the workshop for service.

General

In this operator's manual, left and right, backward and forward are used in relation to the machine's normal driving direction.

Continuous dedication to improve our products require that specifications and design are subject to change without notice.

Driving and Transport on Public Roads

Check applicable road traffic regulations before transporting on public roads. If the machine is transported, you must always use approved fastening equipment and ensure that the machine is well anchored. DO NOT operate this machine on public roadways.

Towing

Do not tow this machine, it may cause damage to the drive system.

Do not tow any trailers, etc with this mower. They may jackknife or overturn causing damage to the mower and possibly serious injury to the operator.

Operating

This machine is constructed only for mowing grass on lawns and other free and even ground without obstacles such as stones, tree stubs, etc. The machine can also be used for other tasks when equipped with special accessories provided by the manufacturer, for which the operating instructions are provided in conjunction with delivery. All other types of use are incorrect. The manufacturer's directions concerning operation, maintenance, and repairs must be carefully followed.

Lawnmowers and all power equipment, can be potentially dangerous if used improperly. Safety requires good judgement, careful use in accordance with these instructions and common sense.

The machine must only be operated, maintained, and repaired by persons that are familiar with the machine's special characteristics and who are well versed in the safety instructions. Use only approved repair parts to maintain this machine.

Accident prevention regulations, other general safety regulations, occupational safety rules, and traffic regulations must be followed without fail.

Unauthorized modifications to the design of the machine may absolve the manufacturer from liability for any resulting personal injury or property damage.

INTRODUCTION

Good Service

Husqvarna's products are sold all over the world and only in specialized retail stores with complete service. This ensures that you as a customer receive only the best support and service. Before the product is delivered, the machine has, for example, been inspected and adjusted by your retailer, see the certificate in the Service Journal in this operator's manual.

When you need spare parts or support in service questions, warranty issues, etc., please consult the following professional:

This Operator's Manual belongs to the machine with manufacturing number:	Engine	Transmission

Manufacturing Number

The machine's manufacturing number can be found on the printed plate affixed to the left in the engine compartment. Stated on the plate, from the top are:

- The machine's type designation (I.D.).
- The manufacturer's type number (Model).
- The machine's serial number (Serial no.)

Please state the type designation and serial number when ordering spare parts.

The engine's manufacturing number is stamped on one of the valve covers.

The plate states:

- The engine's model.
- The engine's type.
- Code

Please state these when ordering spare parts.

The Hydro Drive IZ gears have a barcode decal affixed to the rear of the gears.

SYMBOLS AND DECALS

Symbols and Decals

These symbols are found on the machine and in the operator's manual. Study them carefully so that you know what they mean.



Used in this publication to notify the reader of a risk of **personal injury or death**, particularly if the reader should neglect to follow instructions given in the manual.

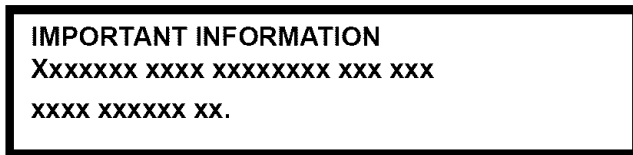

Used in this publication to notify the reader of a risk of **material damage**, particularly if the reader should neglect to follow instructions given in the manual. Used also when there is a potential for misuse or misassembly.



Reverse



Neutral



Fast



Slow



Choke



Fuel



Warning!



Parking brake



CE conformity marking. Only for European market

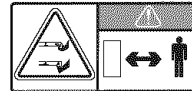

Warning! Rotating blades, keep away from the discharge deck



Do not touch rotating parts



Battery acid is corrosive, explosive, and flammable



Do not stand here



Noise emissions to the surroundings in accordance with the European Union's directive. The machine's emission is stated in the chapter TECHNICAL DATA and on the decals.



Use protective glasses



Use protective gloves

Only machines for European market

SYMBOLS AND DECALS

Read
Operators
Manual

Shut off engine
& remove key
before
performing any
maintenance or
repair work.

Keep a safe
distance from
the machine.

Use on
slopes no
greater
than 10°.

No
passengers

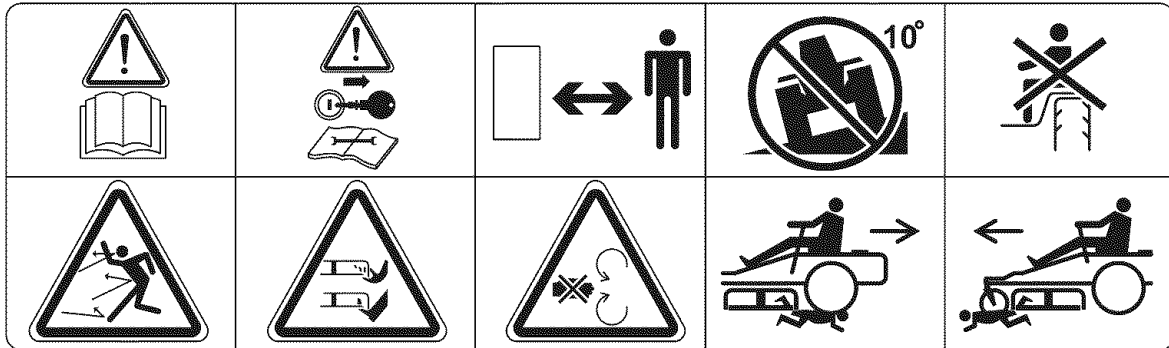

Whole
body
exposure
to thrown
objects.

Severing
of fingers
& toes.

Do not open
or remove
safety
shields while
engine is
running.

Careful
backing up,
watch for
other people.

Careful going
forward,
watch for
other people.



Moving sharp blades
under cover

SAFETY INSTRUCTIONS

Safety Instructions

These instructions are for your safety. Read them carefully.



WARNING!

This symbol means that important safety instructions need to be emphasized. It concerns your safety.

IMPORTANT: THIS CUTTING MACHINE IS CAPABLE OF AMPUTATING HANDS AND FEET AND THROWING OBJECTS. FAILURE TO OBSERVE THE FOLLOWING SAFETY INSTRUCTIONS COULD RESULT IN SERIOUS INJURY OR DEATH.

General Operation

- Read, understand, and follow all instructions on the machine and in the manual before starting.
- Do not put hands or feet near rotating parts or under the machine. Keep clear of the discharge opening at all times.
- Only allow responsible adults, who are familiar with the instructions, to operate the machine.
- Clear the area of objects such as rocks, toys, wire, etc., which could be picked up and thrown by the blades.
- Be sure the area is clear of bystanders before operating. Stop machine if anyone enters the area.
- Never carry passengers. The machine is only intended for use by one person.
- Do not mow in reverse unless absolutely necessary. Always look down and behind before and while backing.
- Never direct discharged material toward anyone. Avoid discharging material against a wall or obstruction. Material may ricochet back toward the operator. Stop the blades when crossing gravel surfaces.
- Do not operate machine without the entire grass catcher, discharge guard, or other safety devices in place and working.
- Slow down before turning.
- Never leave a running machine unattended. Always turn off blades, set parking brake, stop engine, and remove keys before dismounting.

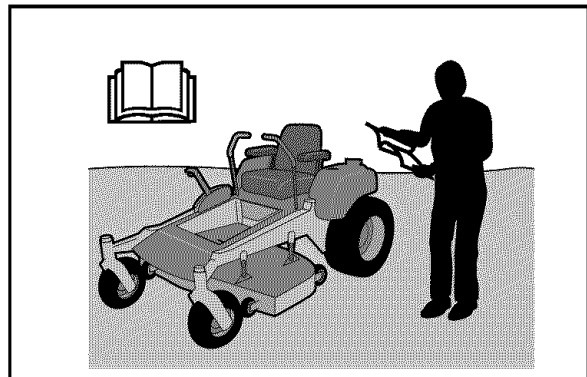

8011-512

Read the operator's manual before starting the machine

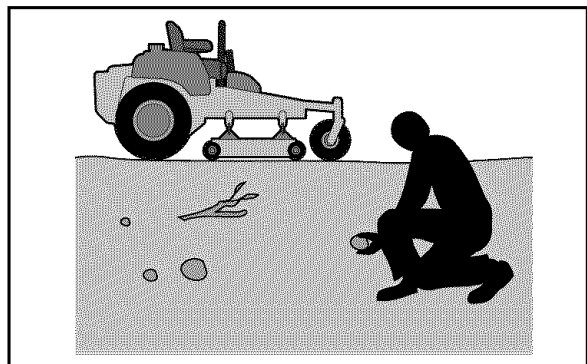

8011-513

Clear the area of objects before mowing



8011-520

Never take passengers

SAFETY INSTRUCTIONS

- Disengage blades when not mowing. Shut off engine and wait for all parts to come to a complete stop before cleaning the machine, removing the grass catcher, or unclogging the discharge guard.
- Operate machine only in daylight or good artificial light.
- Do not operate the machine while under the influence of alcohol or drugs.
- Watch for traffic when operating near or crossing roadways.
- Use extra care when loading or unloading the machine into a trailer or truck.
- Always wear eye protection when operating machine.
- Data indicates that operators, age 60 years and above, are involved in a large percentage of riding mower-related injuries. These operators should evaluate their ability to operate the riding mower safely enough to protect themselves and others from serious injury.
- Follow the manufacturer's recommendation for wheel weights or counterweights.
- Never allow children or other persons not trained in the use of the machine to use or service it. Local laws may regulate the age of the user. Anyone who operates this machine should first read and understand this Operator's Manual.
- Keep machine free of grass, leaves or other debris build-up which can touch hot exhaust / engine parts and burn. Do not allow the mower deck to plow leaves or other debris which can cause build-up to occur. Clean any oil or fuel spillage before operating or storing the machine. Allow machine to cool before storage.



WARNING!

Engine exhaust and certain vehicle components contain or emit chemicals considered to cause cancer, birth defects, or other reproductive system damage. The engine exhaust contains carbon monoxide, which is a odorless, colorless, poisonous gas. Do not use the machine in enclosed spaces.

SAFETY INSTRUCTIONS

Personal Safety Equipment



WARNING!

When using the machine, approved personal protective equipment (shown in illustrations) shall be used. Personal protective equipment cannot eliminate the risk of injury but it will reduce the degree of injury if an accident does happen. Ask your retailer for help in choosing the right equipment.

- Make sure that you have first aid equipment close at hand when using the machine.
- Never use the machine when barefoot. Always wear protective shoes or boots, preferably with steel toecaps.
- Always wear approved protective glasses or a full visor when assembling or driving.
- Always wear gloves when handling the blades.
- Never wear loose clothing that can get caught in moving parts.
- Use ear protectors to avoid damage to hearing.

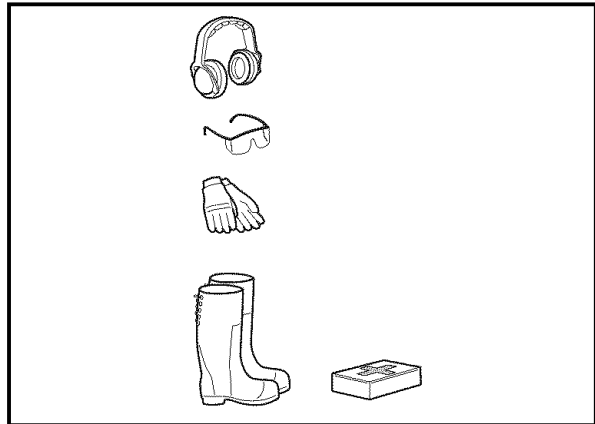

8011-670

Personal protective equipment

Slope Operation

Slopes are a major factor related to loss of control and tip-over accidents, which can result in severe injury or death. Operation on all slopes requires extra caution. If you cannot back up the slope or if you feel uneasy on it, do not mow it.

- Mow up and down slopes (10 degrees maximum), not across.
- Watch for holes, ruts, bumps, rocks, or other hidden objects. Uneven terrain could overturn the machine. Tall grass can hide obstacles.
- Choose a low ground speed so that you will not have to stop while on the slope.
- Do not mow on wet grass. Tires may lose traction.
- Avoid starting, stopping, or turning on a slope. If the tires lose traction, disengage the blades and proceed slowly straight down the slope.
- Keep all movement on the slopes slow and gradual. Do not make sudden changes in speed or direction, which could cause the machine to roll over.

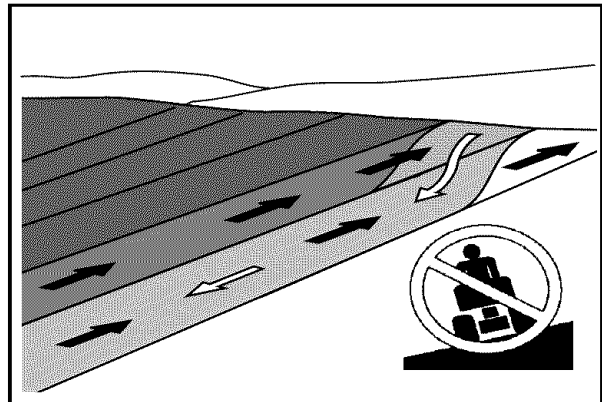

6003-004

Mow up and down, not side-to-side



WARNING!

Do not drive up or down hills with slopes greater than 10 degrees. And do not drive across any slopes.

SAFETY INSTRUCTIONS

- Use extra care while operating machine with grass catchers or other attachments; they can affect the stability of the machine. Do not use on steep slopes.
- Do not try to stabilize the machine by putting your foot on the ground.
- Do not mow near drop-offs, ditches, or embankments. The machine could suddenly roll over if a wheel is over the edge or if the edge caves in.

Children

Tragic accidents can occur if the operator is not alert to the presence of children. Children are often attracted to the machine and the mowing activity. *Never* assume that children will remain where you last saw them.

- Keep children out of the mowing area and in the watchful care of a responsible adult other than the operator.
- Be alert and turn machine off if a child enters the area.
- Before and while backing, look behind and down for small children.
- Never carry children, even with the blades shut off. They may fall off and be seriously injured or interfere with safe machine operation. Children who have been given rides in the past may suddenly appear in the mowing area for another ride and be run over or backed over by the machine.
- Never allow children to operate the machine.
- Use extra care when approaching blind corners, shrubs, trees, or other objects that may block your view of a child.

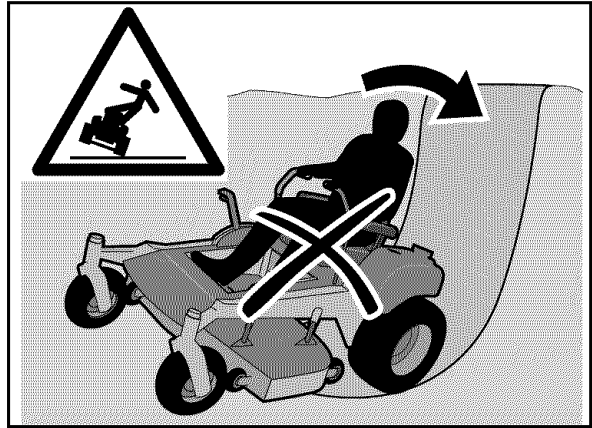

8011-519

Be extra cautious when driving on slopes

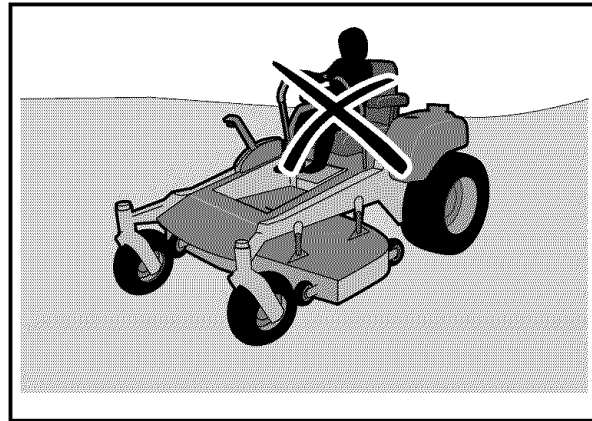

8011-517

Never allow children to operate the machine



8011-518

Keep children away from the work area

SAFETY INSTRUCTIONS

Maintenance



WARNING!

The engine must not be started when the driver's floor plate or any protective plate for the mower deck's drive belt is removed.

Safe Handling of Gasoline

To avoid personal injury or property damage, use extreme care in handling gasoline. Gasoline is extremely flammable and the vapors are explosive.

- Extinguish all cigarettes, cigars, pipes, and other sources of ignition.
- Use only approved gasoline container.
- Never remove gas cap or add fuel with the engine running. Allow engine to cool at least two (2) minutes before refueling.
- Never fuel the machine indoors.
- Never store the machine or fuel container where there is an open flame, spark, or pilot light such as on a water heater or other appliances.
- Never fill containers inside a vehicle or on a truck or trailer bed with plastic liner. Always place containers on the ground away from your vehicle when filling.
- Remove gas-powered equipment from the truck or trailer and refuel it on the ground. If this is not possible, then refuel such equipment with a portable container, rather than from a gasoline dispenser nozzle.
- Keep the nozzle in contact with the rim of the fuel tank or container opening at all times until fueling is complete. Do not use a nozzle lock-open device.
- If fuel is spilled on clothing, change clothing immediately.
- Never overfill fuel tank. Replace gas cap and tighten securely.
- Do not start the engine near spilled fuel.
- Never use gasoline as a cleaning agent.
- If leaks arise in the fuel system, the engine must not be started until the problem has been resolved.
- Check the fuel level before each use and leave space for the fuel to expand, because the heat from the engine and

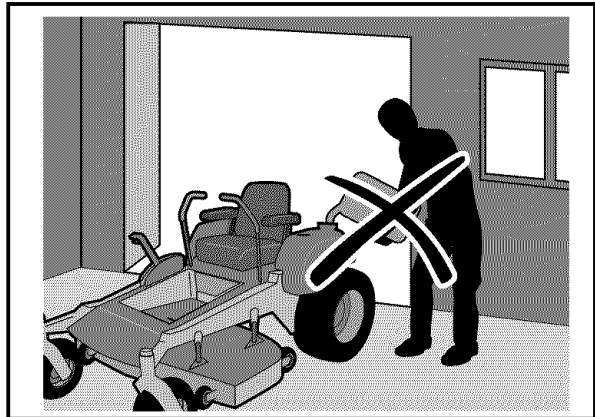

8011-516

Never fill the fuel tank indoors



WARNING!

The engine and the exhaust system, become very hot during operation.

Risk for burns if touched.

Allow engine and exhaust system to cool at least two (2) minutes before refueling

SAFETY INSTRUCTIONS

the sun may otherwise cause the fuel to expand and overflow.

General Maintenance

- Never operate machine in a closed area.
- Keep all nuts and bolts tight to be sure the equipment is in safe working condition.
- Never tamper with safety devices. Check their proper operation regularly.
- Keep machine free of grass, leaves, or other debris build-up. Clean oil or fuel spillage and remove any fuel-soaked debris. Allow machine to cool before storing.
- If you strike a foreign object, stop and inspect the machine. Repair, if necessary, before restarting.
- Never make any adjustments or repairs with the engine running.
- Check grass catcher components and the discharge guard frequently and replace with manufacturer's recommended parts, when necessary.
- Mower blades are sharp. Wrap the blade or wear gloves, and use extra caution when servicing them.
- Check brake operation frequently. Adjust and service as required.
- Maintain or replace safety and instruction labels, as necessary.
- Do not modify safety equipment. Check regularly to be sure it works properly. The machine must not be driven with defective or unmounted protective plates, protective cowlings, safety switches, or other protective devices.
- Do not change the settings of governors and avoid running the engine with overly high engine speeds. If you run the engine too fast, you risk damaging the machine components.
- Be very careful when handling battery acid. Acid on skin can cause serious corrosive burns. If you spill battery acid on your skin, rinse immediately with water.

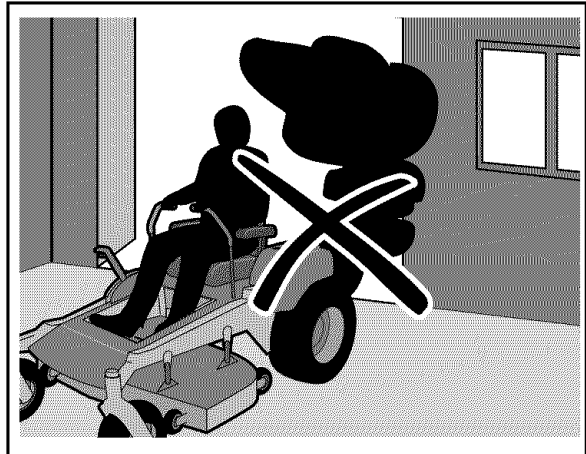

8011-515

Never drive the machine in an enclosed space



Always use protective glasses when handling the battery.



WARNING!

The battery contains lead and lead compounds, chemicals that are considered to cause cancer, birth defects, and other reproductive system damage. Wash your hands after handling the battery.

SAFETY INSTRUCTIONS

- Acid in the eyes can cause blindness, contact a doctor immediately.
- Be careful when servicing the battery. Explosive gases form in the battery. Never perform maintenance on the battery when smoking or near open flames or sparks. The battery can explode and cause serious injury/damage.
- Ensure that nuts and bolts, especially the fastening bolts for the blade attachments, are properly tightened, torqued and that the equipment is in good condition.
- Do not modify safety equipment. Check regularly to be sure it works properly. The machine must not be driven with defective or unmounted protective plates, protective cowlings, safety switches, or other protective devices.
- Do not change the settings of governors and avoid running the engine with overly high engine speeds. If you run the engine too fast, you risk damaging the machine components.
- Sparking can occur when working with the battery and the heavy cables of the starter circuit. This can cause battery explosion, fire or eye injury. Sparking in this circuit can not occur after the chassis cable (normally negative, black) is removed from the battery.

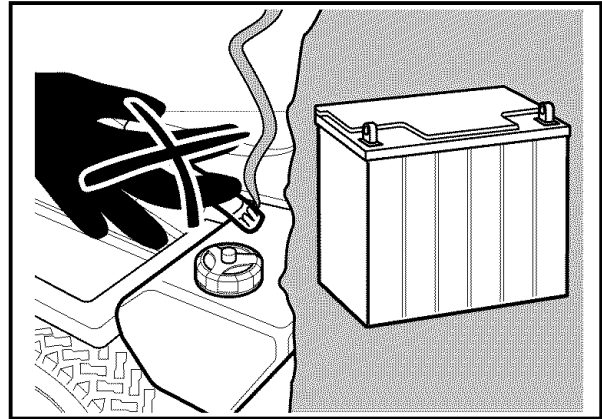

6003-009

Do not smoke when performing maintenance on the battery. The battery can explode and cause serious injury/damage

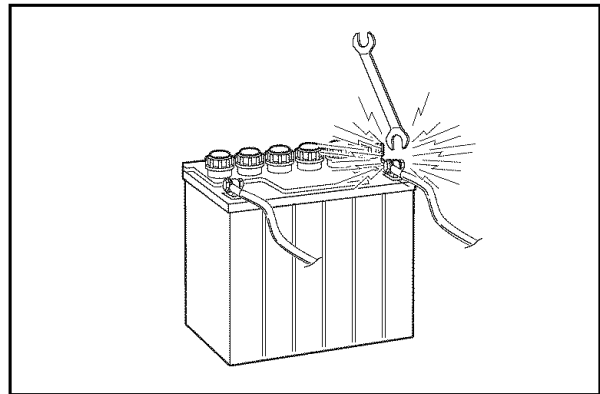

6006-728

Risk of sparking



WARNING!
Avoid electrical sparking and its consequences by the following routines:

- Use protective goggles.
- Ensure that the fuel filler cap is mounted tightly and no flammable substance is stored in an open vessel.
- Never work with the starter circuit if there is spilled fuel.
- Disconnect the chassis cable from the battery first and reconnect it last.
- Do not make a bridge short circuit across the starter relay to run the starter.
- Never use the machine indoors or in spaces lacking proper ventilation. The exhaust fumes contain carbon monoxide, an odorless, poisonous, and lethal gas.
- Stop and inspect the equipment if you

SAFETY INSTRUCTIONS

run over or into anything. If necessary, make repairs before starting.

- Never make adjustments with the engine running.
- The machine is tested and approved only with the equipment originally provided or recommended by the manufacturer. Only use approved repair parts for the machine.
- The blades are sharp and can cause cuts and gashes. Wrap the blades or use protective gloves when handling them.
- Check the parking brake's functionality regularly. Adjust and service as necessary.
- The mulch blades should only be used in familiar areas when higher quality mowing is desired.
- Reduce the risk of fire by removing grass, leaves, and other debris that may have accumulated on the machine. Allow the machine to cool before putting it in storage.
- Regularly clean deck and underside of deck, avoid spraying engine and electrical components with water.

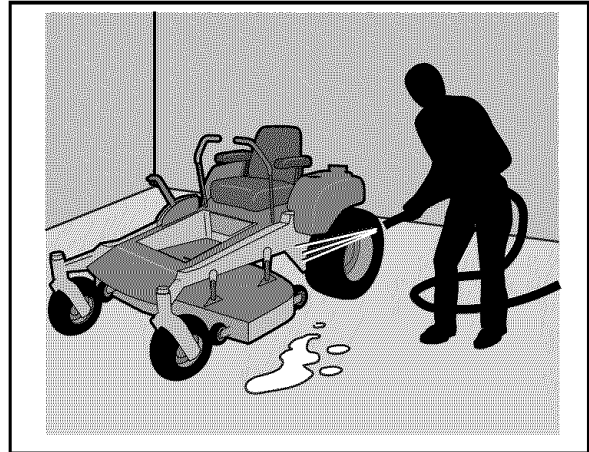

8011-644

Clean the machine regularly

Transport

- The machine is heavy and can cause serious crushing injuries. Be extra cautious when it is loaded on or unloaded from a vehicle or trailer.
- Use an approved trailer to transport the machine. Activate the parking brake, turn off the fuel supply, and fasten the machine with approved fastening devices, such as bands, chains, or straps, when transporting.
- Do not operate this machine on public roadways.
- Check and abide by local traffic regulations before transporting the machine on any road.
- Do not tow this machine, it may cause damage to the drive system.
- Do not tow any trailers, etc. with this mower. They may jackknife or overturn causing damage to the mower and possibly serious injury to the operator.

IMPORTANT INFORMATION

The parking brake is not sufficient to lock the machine in place during transport. Ensure that the machine is well fastened to the transport vehicle. Always reverse the machine onto the transport vehicle to avoid tipping it over.

SAFETY INSTRUCTIONS

Customer responsibilities

- Read and observe the safety rules.
- Follow a regular schedule in maintaining, caring for and using your mower.
- Follow the instructions under "Maintenance" and "Storage" sections of this owner's manual.
- This machine has no brain. Use yours!



WARNING!

This mower is equipped with an internal combustion engine and should not be used on or near any unimproved forest-covered, bush-covered or grass-covered land unless the engine's exhaust system is equipped with a spark arrester meeting applicable local or state laws (if any). If a spark arrester is used, it should be maintained in effective working order by the operator.

A spark arrester for the muffler is available through your authorized Husqvarna dealer.

CONTROLS

Controls

This operator's manual describes the Husqvarna Zero Turn Rider. The rider is fitted with a Briggs and Stratton four-stroke engine developing 22-24 horse power.

Transmission from the engine is made via two belt-driven hydrostat transaxles, one for each drive wheel. Using the left and right steering controls, the flow is regulated and thereby the direction and speed.

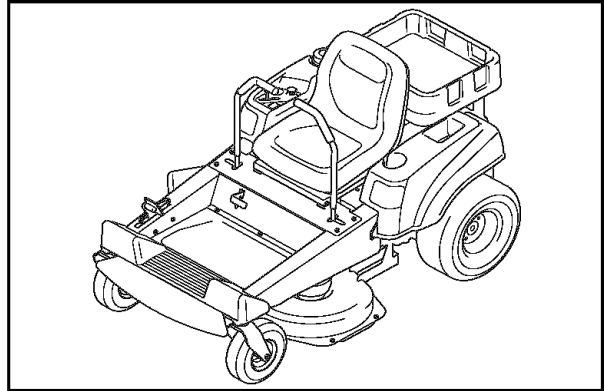

8011-648

Zero Turn Rider

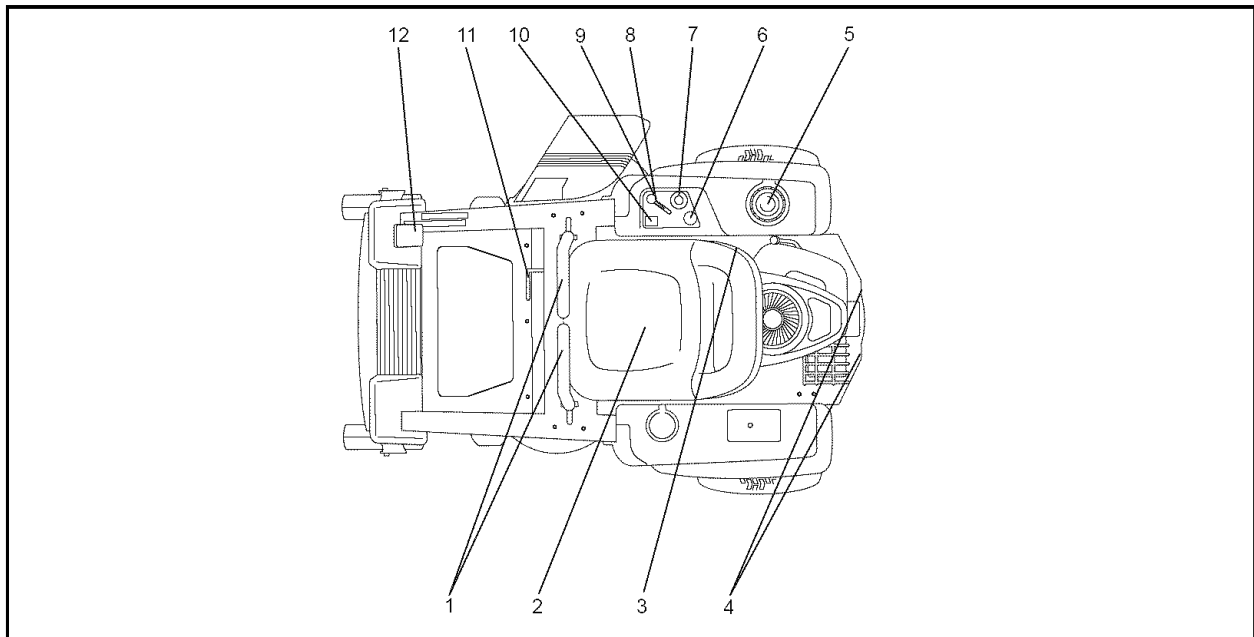

8011-735

Locations of the controls

Control Locations

	Page		Page
1. Motion control, levers	17	8. Choke control	21
2. Seat adjustment knobs	18	9. Throttle control	21
3. Fuses	18	10. Hour meter	22
4. By-pass linkages	19	11. Parking brake	22
5. Fuel tank cap	20	12. Cutting height pedal	23
6. Blade switch	20		
7. Ignition switch	21		

CONTROLS

1. Motion Control Levers

The machine's speed and direction are continuously variable using the two steering controls. The steering controls can be moved forward or backward about a neutral position. Furthermore, there is a neutral position, which is locked if the steering controls are moved outward.

When both controls are in the neutral position (N), the machine stands still.

By moving both controls an equal amount forward or backward, the machine moves in a straight line forward or backward respectively.

In order, for example, to turn right while moving forward, move the right control towards the neutral position. The rotation of the right wheel is reduced and the machine turns to the right.

Zero turn can be achieved by moving one control backward (behind the neutral position) and carefully moving the other steering control forward from its neutral position. The rotation direction when zero turning is determined by which steering control is moved backward behind the neutral position. If the left steering control is pulled backward, the machine turns to the left. Use extra care when using this maneuver.

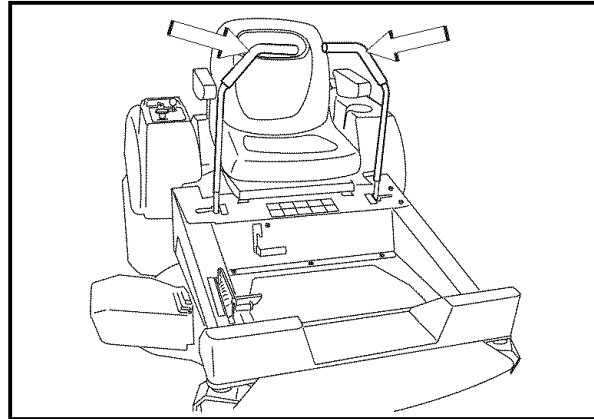

8011-751

Motion control levers



WARNING!

The machine can turn very rapidly if one steering control is moved much further forward than the other.

Tracking

If the mower is not tracking straight, check the air pressure in both rear tires. Recommended air pressure is 15 psi (1 bar). Tracking must be checked on a flat and level concrete or blacktop surface. If unit still does not track straight, contact a Husqvarna workshop for adjustment.

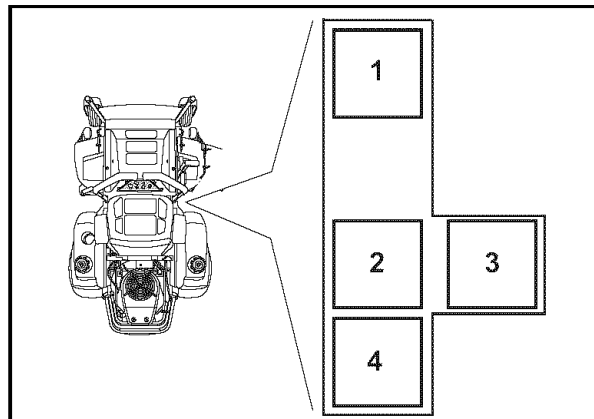

8011-791

- 1 Forward
- 2 Neutral
- 3 Neutral slot, Neutral lock
- 4 Reverse

Motion control lever pattern (right side)

CONTROLS

2. Seat adjustment knobs

The seat can be adjusted lengthways. When making adjustments, loosen the four knobs under the seat pan, after which the seat can be moved backward or forward. Do not forget to tighten the knobs.

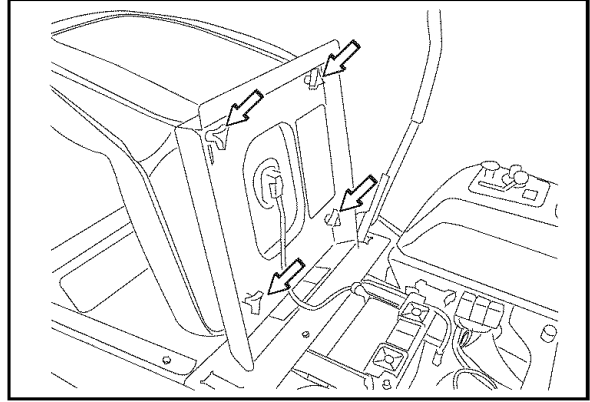

CZ-1

Lengthways adjustment

3. Fuses

The fuses are located in the right front corner of the engine compartment. They are flat pin fuses of the same type used in automobiles.

There are two fuses.

Fuse ratings and functions:

- 20 A, Primary fuse.
- 7.5 A, Mower deck coupling.

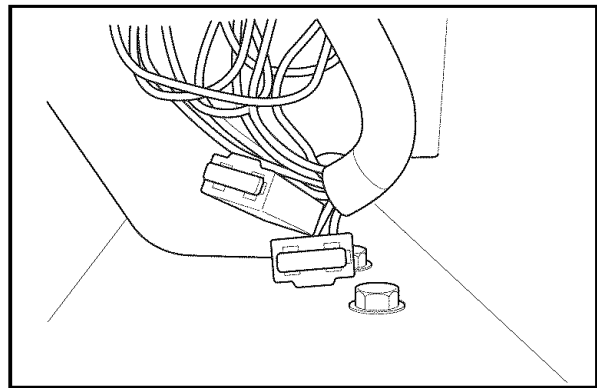

8011-483

Fuses

CONTROLS

4. By pass linkages

When pushing or pulling the mower, be sure to engage the IZT (Integrated Zeroturn Transaxle) bypass linkages. The IZT bypass linkages are located on the rear of the frame, below the rear engine guard.

- Raise the deck into the highest cutting position.
- Pull the IZT bypass linkages out and into the slots and release so that it is held in the bypass position.
- To reengage the IZT's to drive, reverse the above procedure.

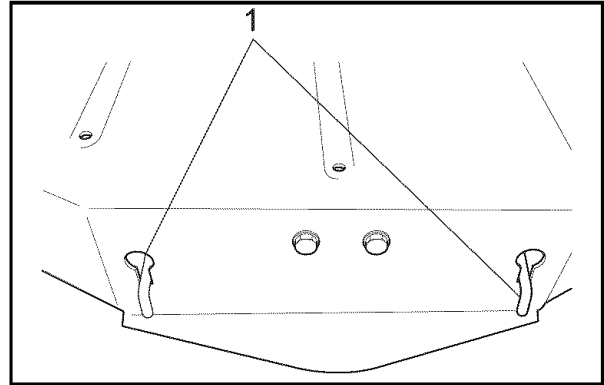

8011-721

1. IZT Bypass linkage

Bypass linkages

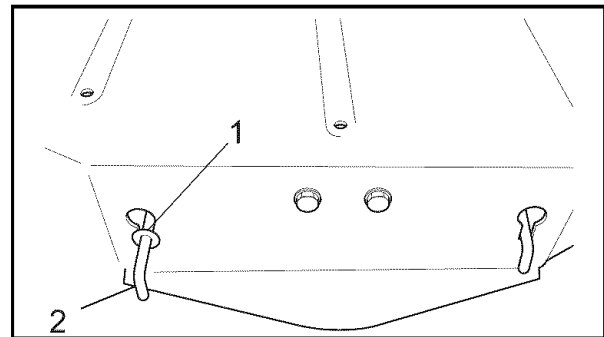

8011-722

1. Head outside of rear deck

2. IZT Bypass linkage in bypass position

Bypass position

CONTROLS

5. Refueling

The machine has one fuel tank, just behind the seat. The tank capacity is 3 gallons (11.4 liters).

The engine will run on a minimum of 85-octane unleaded gasoline (no oil mix). Environmentally adapted alkylate gasoline can be used. See also Technical Data concerning ethanol fuel. Methanol fuel is not allowed.



WARNING!

Gasoline is highly flammable. Observe caution and fill the tank outdoors (see the safety rules).



WARNING!

The engine and the exhaust system, become very hot during operation.

Risk for burns if touched.

Allow engine and exhaust system to cool at least two (2) minutes before refueling.



WARNING!

Fill to bottom of filler neck. Do not overfill. Wipe off any spilled oil or fuel. Do not store, spill or use gasoline near an open flame.

When operating in temperatures below 32° F. (0° C.), use fresh, clean winter grade gasoline to help insure good cold weather starting.

6. Blade switch

In order to engage the mower deck, pull the knob out; the mower blades are disengaged when the knob is depressed.

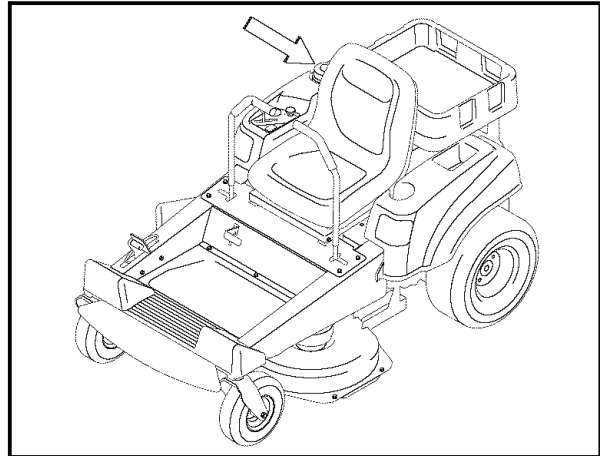

8011-752

Fuel tank

IMPORTANT INFORMATION

Experience indicates that alcohol blended fuels (called gasohol, ethanol or methanol) can attract moisture which leads to separation and formation of acids during storage. Acidic gas can damage the fuel system of an engine while in storage. To avoid engine problems, the fuel system should be emptied before storage of 30 days or longer. Drain the gas tank, start the engine and let it run until the fuel lines and carburetor are empty. Use fresh fuel the next season. See Storage Instructions for additional information. Never use engine or carburetor cleaners in the fuel tank or permanent damage may occur.

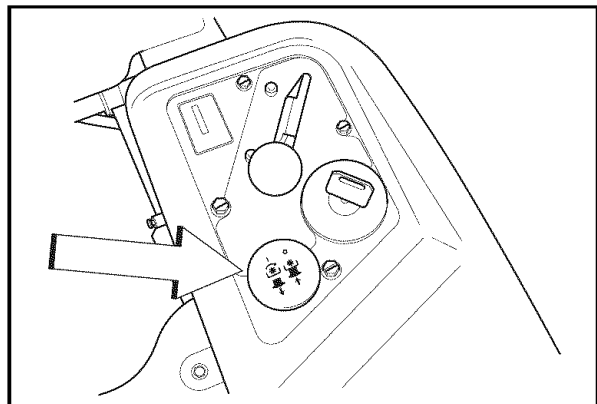

8011-750

Blade Switch

CONTROLS

7. Ignition Switch

The ignition key is placed on the driver's panel and is used to start and stop the engine.

IMPORTANT INFORMATION

Do not run the starter for more than five seconds each time. If the engine does not start, wait about 10 seconds before re-trying.

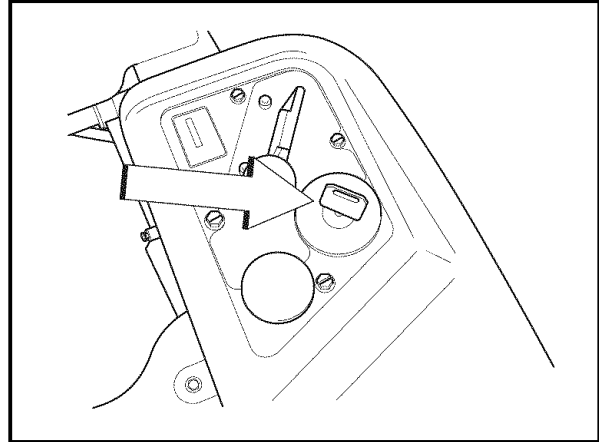

8011-748

Ignition key and hour meter

8. Choke Control

The choke mode is used for cold starts in order to provide the engine with a richer fuel mixture.

The Throttle control is equipped with a choke detent. Pressing the throttle control all of the way forward will choke the engine. For full throttle, press throttle control forward until you feel the choke detent.

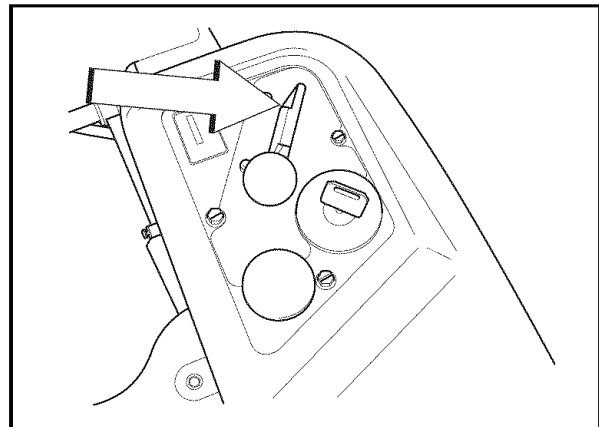

8011-480

Choke control detent

9. Throttle Control

The throttle control regulates the engine speed and thereby the rate of rotation of the blades, assuming the blade switch is pulled out, see Engaging the Mower Deck.

In order to increase or decrease the engine speed, the control is moved.

Avoid idling the engine for long periods, as there is a risk of fouling the spark plug.

USE FULL THROTTLE WHEN MOWING, for best mower performance and battery charging.

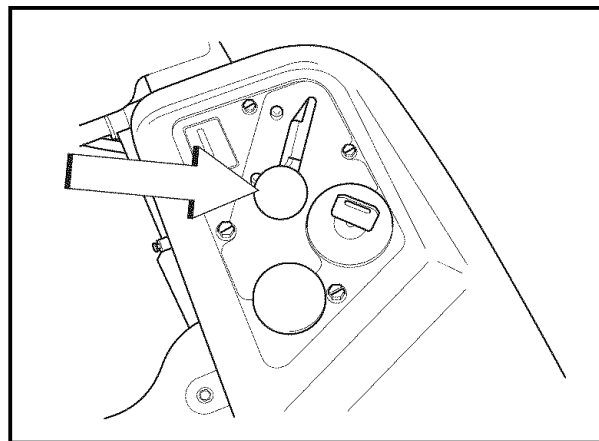

8011-747

Throttle control

CONTROLS

10. Hour Meter

The hour meter displays the total operating time.

It will flash CHG OIL (Change Oil) at 50 hour intervals. The flash duration is one hour before and one hour after the interval. The CHG OIL icon will come on and shut off automatically. The hour meter can not be manually reset.

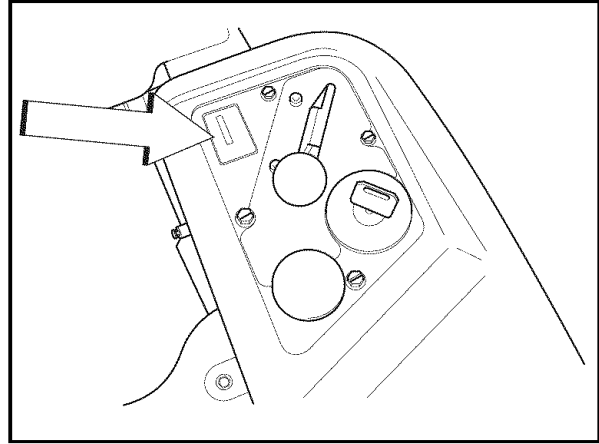

8011-749

Hour meter

11. Parking Brake

IMPORTANT INFORMATION

The machine must be stopped before activating the parking brake.

The parking brake is found below the front of the seat. Pull the lever upward to activate the brake and downward to release it.

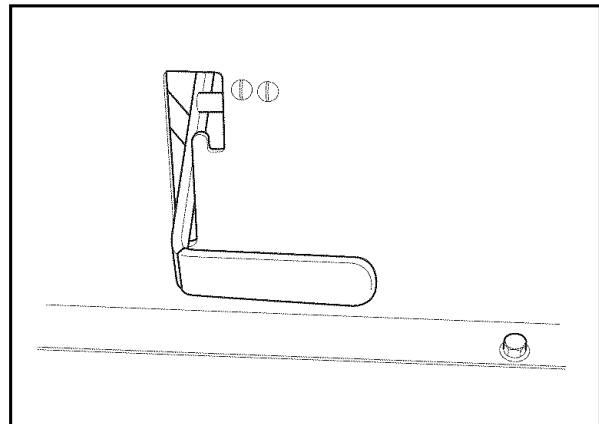

8011-481

Parking brake not activated

CONTROLS

12. Cutting height pedal

The deck cutting height is obtained by pressing the foot pedal forward to lift the deck. To lower the deck, you apply pressure to the top side of the foot pedal and allow it to pivot while allowing the lift arm to rotate to the rear of the unit. To stop in a desired cutting position, rotate the foot pedal down into the notch in the height plate. The cutting height range is from 1 1/2" (38 mm) to 5" (127 mm) in 1/2" (13 mm) increments. The heights are measured from the ground up to the blade tip with the engine not running

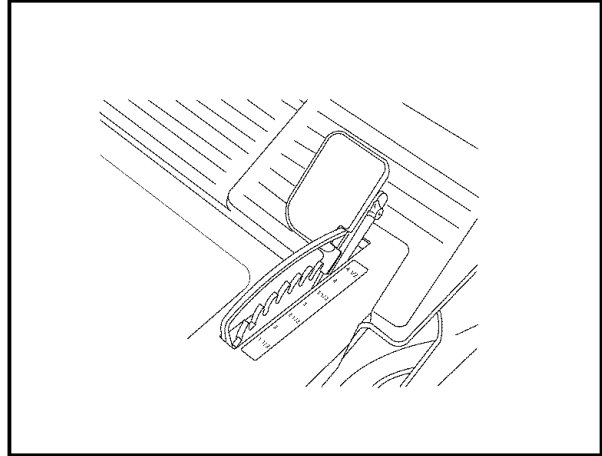

8011-753

Cutting height pedal

IMPORTANT INFORMATION

In order to obtain an even cutting height it is important that the air pressure in all four tires is the same 15 psi (1 bar).

Accessories

For mulching, there is a BioClip attachment available. This is mounted underneath the mower deck and consists of discharge cover and blades.

OPERATION

Operation

Read "Safety Instructions" section and following pages, if you are unfamiliar with the machine.

Training

Zero turn mowers are far more maneuverable than typical riding mowers due to their unique steering capabilities.

We suggest when first operating the mower, use a reduced throttle speed and reduced ground speed by NOT moving control levers to the furthest forward or reverse positions during initial operation, or until operator becomes comfortable with controls. We also suggest first time users, or new users to ZeroTurn mowers to become familiar with the mowers movement on a hard surface, such as concrete or blacktop PRIOR to attempting to operate on turf. Until operator becomes comfortable with mower controls and zero turning capability, they may damage turf due to over aggressive maneuvers.

To move forward and backward

The direction and speed of the mowers movements is effected by the movement of the control lever(s) on each side of mower. The left control lever controls the left wheel. The right control lever controls the right wheel.

IMPORTANT INFORMATION

When control levers are in the reverse position they return to neutral when released. This may cause the mower to suddenly stop.

First time users should push mower (see "Moving by Hand" in the "Operation" section) to an open, flat area, without other people or vehicles/obstacles near by. In order to move unit under its own power, the operator must be in the seat, start engine (see "Before Starting" in "Operation" section), adjust engine speed to idle, disengage parking brake, do not engage blades at this time, rotate control levers inward. As long as the control levers have not been moved forward or backwards, mower will not move. Slowly move both control levers forward slightly, this will allow mower to start moving forward in a straight line. Pull back on control levers to the neutral position and mower should stop moving. Pull back slightly on control levers, this will allow mower to start moving backwards. Push forward on control levers to the neutral position and mower should stop moving.

To turn to the right

While moving in a forward direction, pull the right lever back towards the neutral position while maintaining the position of the left lever, this will slow the rotation of the right wheel and cause the machine to turn in that direction.

To turn to the left

While moving in a forward direction pull the left lever back towards the neutral position while maintaining the position of the right lever, this will slow the rotation of the left wheel and cause the machine to turn in that direction.

To zero turn

While moving in a forward direction, first pull both control levers back until the mower stops or slows dramatically. Then by alternating one lever slightly to the forward position and the other in the reverse position.

OPERATION

Before Starting

- Read the sections Safety Instructions and Controls before starting the machine.
- Perform the daily maintenance before starting (see Maintenance Schedule in the Maintenance section).
- Check that there is sufficient fuel in the fuel tank.
- Adjust the seat to the desired position.

The following conditions must be fulfilled before the engine can be started:

- The driver must be seated on the seat.
- The blade switch for engaging the mower blades must be depressed.
- The parking brake must be on.
- Both steering controls must be in the locked (outer) neutral position.

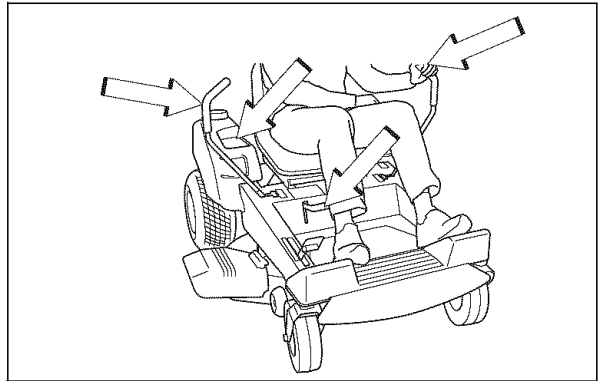

8011-484

Start conditions

Starting the Engine

1. Sit on the seat.
2. Raise the mower deck by depressing the pedal forward to the locked position (transport position).
3. Activate the parking brake.

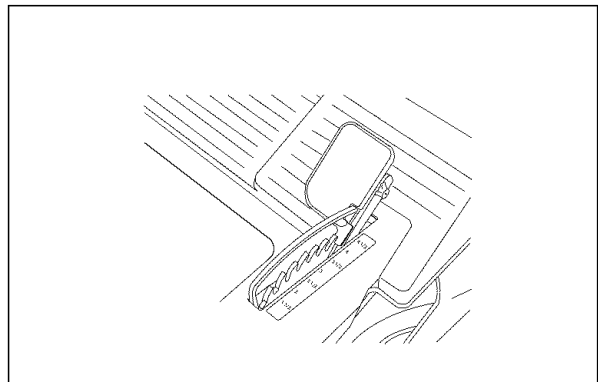

8011-753

Raise the mower deck

OPERATION

4. Disengage the mower blades by depressing the blade switch.

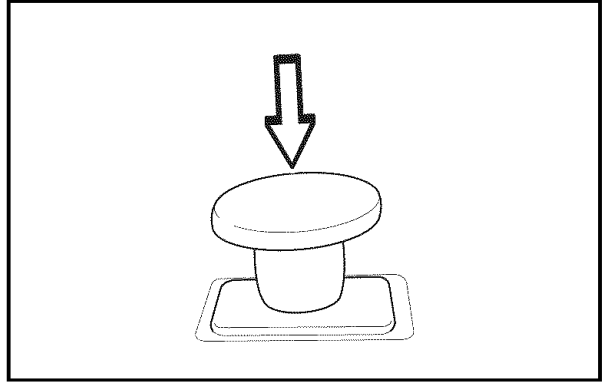

8011-668

Depress the control for disengaging the mower deck

5. Move the steering controls outward to the locked (outer) neutral position.

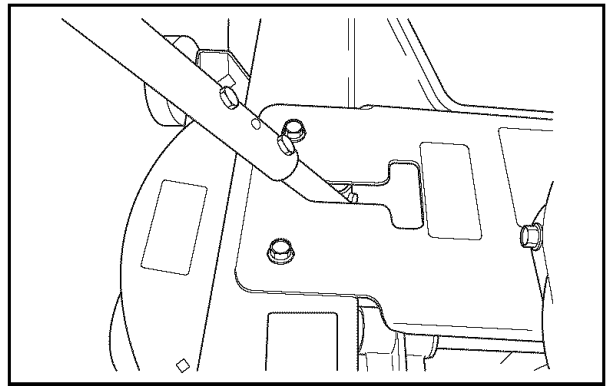

8011-489

Steering controls in the outward, locked neutral position

6. Move the throttle to the middle position.
7. If the engine is cold, the throttle control should be pushed forward to its choke position.

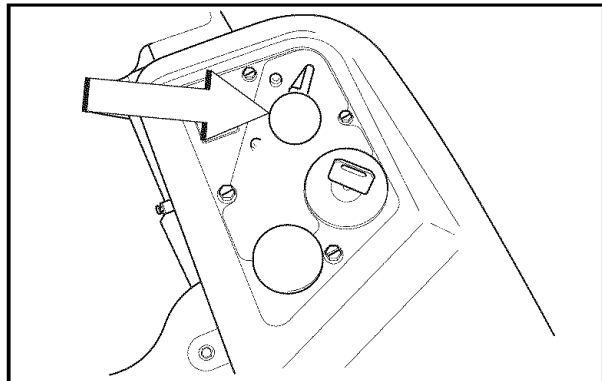

8011-754

Set the throttle

OPERATION

8. Press in and turn the ignition key to the start position.

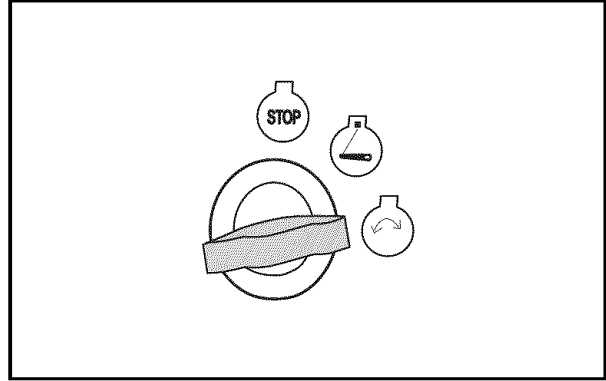

8011-742

Turn to the start position

9. When the engine starts, immediately release the ignition key back to the run position.

IMPORTANT INFORMATION

Do not run the starter for more than 5 seconds each time. If the engine does not start, wait about 10 seconds before re-trying.

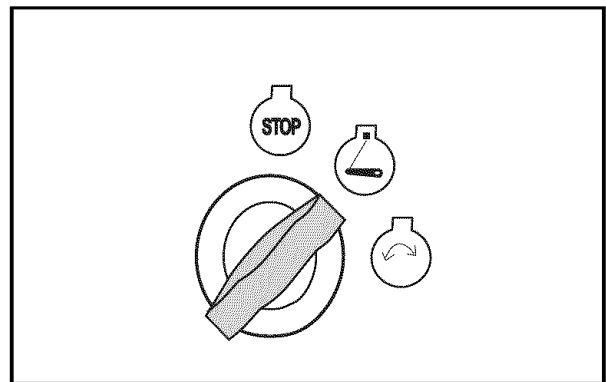

8011-743

Return to run position

10. Set the desired engine speed with the throttle.
Allow the engine to run at a moderate speed, "half throttle", for 3-5 minutes before loading it too heavily.
USE FULL THROTTLE WHEN MOWING (no choke).



WARNING!

Engine exhaust and certain vehicle components contain or emit chemicals considered to cause cancer, birth defects, or other reproductive system damage. The engine exhaust contains carbon monoxide, which is an odorless, colorless, poisonous gas. Do not use the machine in enclosed spaces.

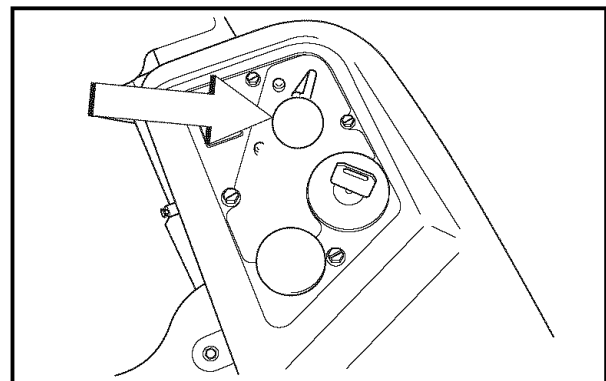

8011-754

Set the engine speed

OPERATION

To start an engine with a weak battery

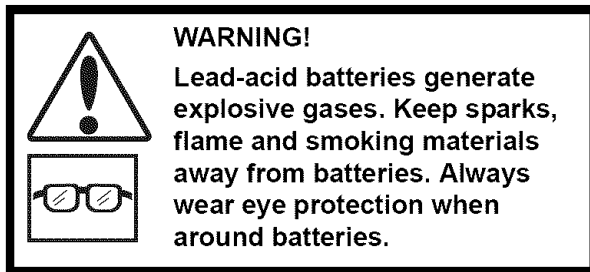

If your battery is too weak to start the engine, it should be recharged. (See "Battery" in the Maintenance Section.)

If "jumper cables" are used for emergency starting, follow this procedure:

IMPORTANT INFORMATION

Your mower is equipped with a 12-volt negative grounded system. The other vehicle must also be a 12-volt negative grounded system. Do not use your mower battery to start other vehicles.

To attach jumper cables

- Connect each end of the RED cable to the POSITIVE (+) terminal on each battery, taking care not to short against chassis.
- Connect one end of the BLACK cable to the NEGATIVE (-) terminal of the fully charged battery.
- Connect the other end of the BLACK cable to a good CHASSIS GROUND on the mower with the discharged battery, away from the fuel tank and battery.

To remove cables, reverse order

- Remove BLACK cable first from chassis and then from the fully charged battery.
- Remove RED cable last from both batteries.

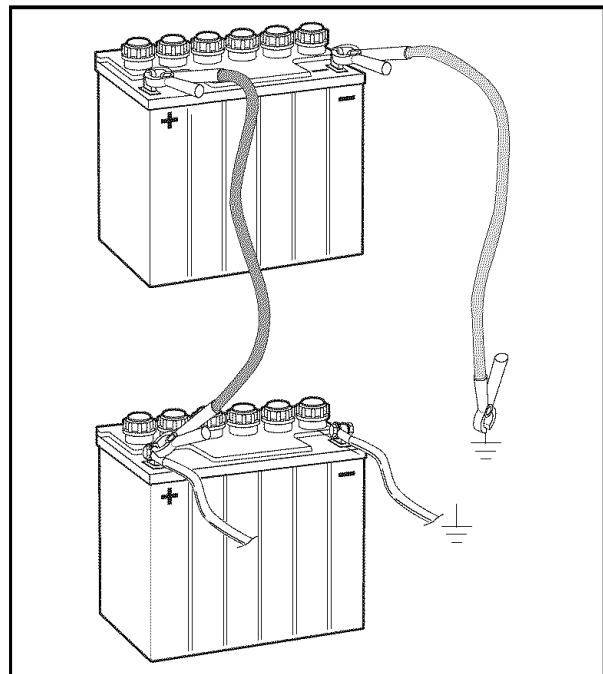

Jumper cables connection

8011-642

OPERATION

Running

1. Release the parking brake by moving the lever downward.

Your mower is equipped with an operator presence system. When the engine is running, any attempt by the operator to leave the seat without first setting the parking brake will shut off the engine.

2. Move the steering controls to the neutral position (N).

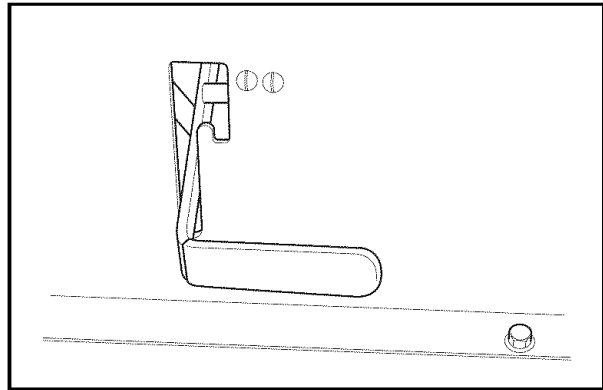

8011-481

Released parking brake

3. Select the cutting height by the cutting height pedal.

IMPORTANT INFORMATION

The mower deck's anti-scalp rollers should be evenly adjusted.

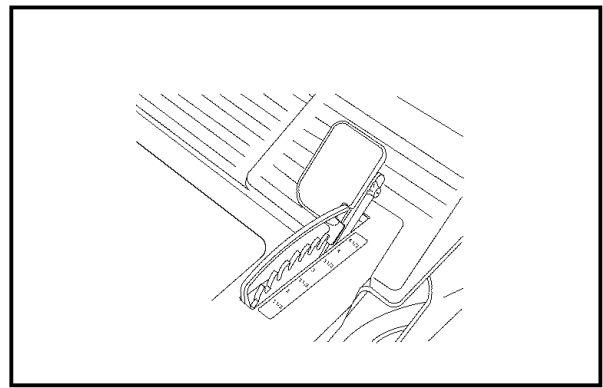

8011-753

Cutting height selection



WARNING!

Ensure that no one is near the machine when engaging the Blade switch.

4. Engage the mower deck by pulling out the blade switch.
5. Move throttle control to full throttle (not choke)
6. The machine's speed and direction are continuously variable using the two steering controls. When both controls are in the neutral position, the machine stands still.

By moving both controls an equal amount forward or backward, the machine moves in a straight line forward or backward respectively.

In order, for example, to turn right while moving forward, move the right control towards the neutral position. The rotation of the right wheel is reduced and the machine turns to the right.

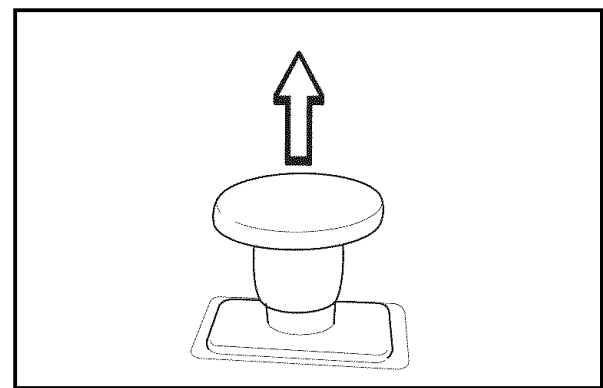

8011-689

Engaging the mower deck

OPERATION

Turning on the spot can be achieved by moving one control backward (behind the neutral position) and carefully moving the other steering control forward from its neutral position.

Operating on hills

Read the Safety Instructions "Driving on Slopes" in the "Safety Instructions".



WARNING!

Do not drive up or down hills with slopes greater than 10 degrees. And do not drive across any slopes.

- The slowest speed possible should be used before starting up or down hills.
- Avoid stopping or changing speed on hills.
- If stopping is absolutely necessary, pull drive levers into the neutral position and push to the outside of the unit and engage the parking brake.

IMPORTANT INFORMATION

Control levers return to neutral when released. This may cause the mower to suddenly stop.

- To restart movement, release the parking brake.
- Pull the control levers back to the center of the mower and press forward to regain forward motion.
- Make all turns slowly.

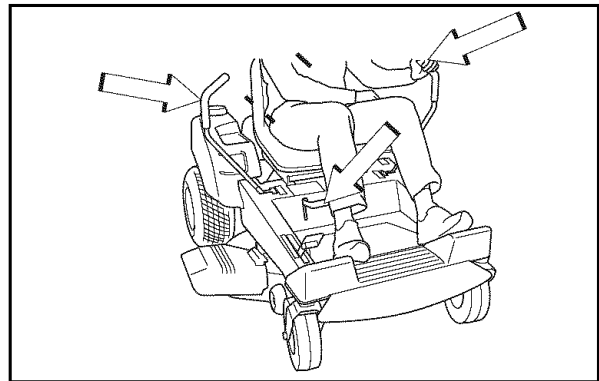

8011-755

Stopping conditions

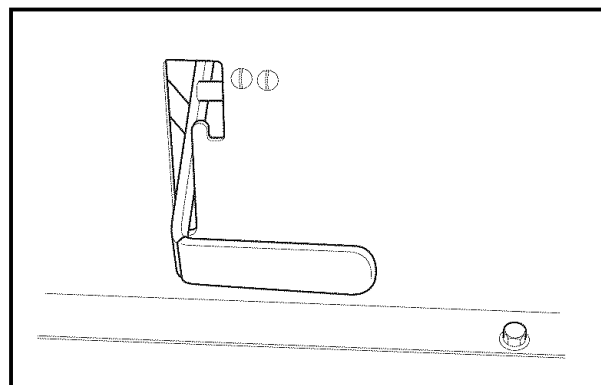

8011-481

Released parking brake

OPERATION

Mowing Tips

- Observe and flag rocks and other fixed objects to avoid collisions.
- Begin with a high cutting height and reduce it until the desired mowing result is attained.

The average lawn should be cut to 2 1/2" (64 mm) during the cool season and over 3" (76 mm) during the hot months. For healthier and better looking lawns, mow often after moderate growth.

For best cutting performance, grass over 6" (15 cm) in height should be mowed twice. Make the first cut relatively high; the second to the desired height.

- The mowing result will be best with a high engine speed (the blades rotate rapidly) and low speed (the rider moves slowly). If the grass is not too long and dense, the driving speed can be increased without negatively affecting the mowing result.
- The finest lawns are obtained by mowing often. The lawn becomes more even and the grass clippings more evenly distributed over the mown area. The total time taken is not increased as a higher operating speed can be used without poor mowing results.
- Avoid mowing wet lawns. The mowing result is poorer because the wheels sink into the soft lawn, clumps build, and the grass clippings fasten under the cowling.
- Hose the mower deck underside with water after each use. When cleaning, the mower deck shall be raised into the transport position. Make sure the mower is cooled and the engine is off.
- Use compressed air to clean top surface of the deck. Avoid flooding water on top surface, engine and electrical components.
- When the mulching kit is used, it is important that the mowing interval is frequent.

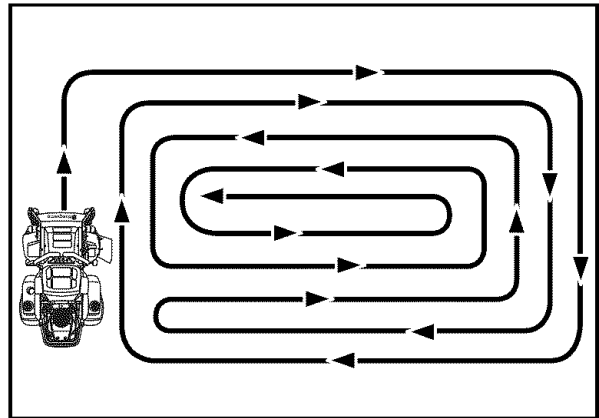
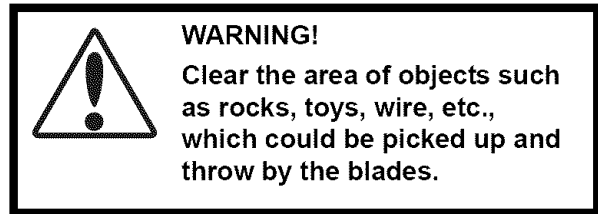

8011-603

Mowing patterns

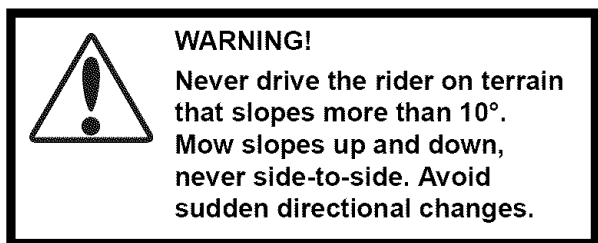

OPERATION

Stopping the Engine

Allow the engine to idle a minute in order to attain normal operating temperature before stopping it, if it has been worked hard. Avoid idling the engine for longer periods, as there is a risk of the spark plugs fouling.

1. Disengage the mower deck by depressing the blade switch.

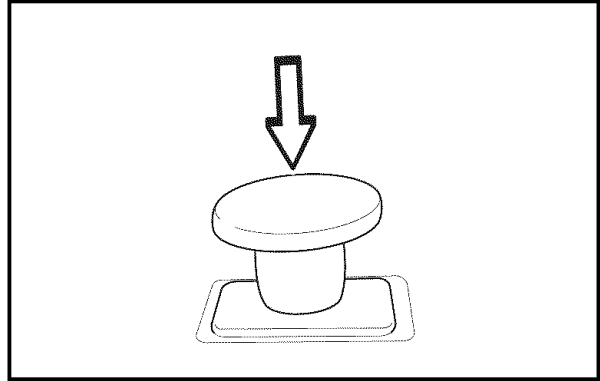

8011-668

Disengage the mower deck

2. Raise the mower deck by depressing the pedal forward to the transport position.
3. When the machine is standing still, activate the parking brake by pulling the lever upward.
4. Move the throttle to the minimum position (tortoise symbol). Turn the ignition key to the stop position.
5. Move the steering controls outward.
6. Remove key. Always remove key when leaving the mower to prevent unauthorized use.

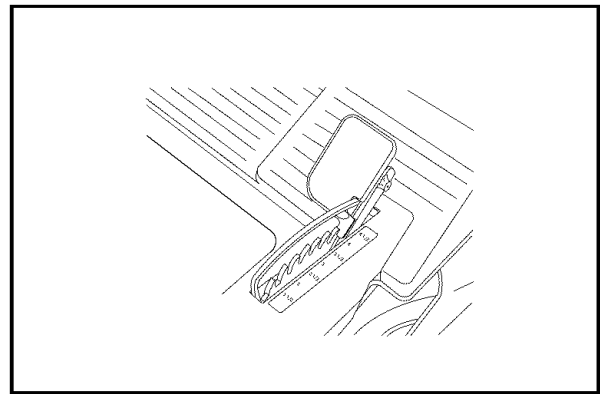

8011-753

Raise the mower deck with the lifting pedal

IMPORTANT INFORMATION

Leaving the ignition switch in any other position than "OFF" will cause the battery to be discharged and the hour meter to accumulate hours.

OPERATION

Moving by Hand



WARNING!
No adjustments or maintenance to be carried out unless:

- the engine stopped,
- the ignition key has removed,
- the parking brake is on.

When pushing or pulling the mower, be sure to engage the IZT (Integrated Zeroturn Transaxle) bypass linkages. The IZT bypass linkages are located on the rear of the frame.

- Raise the deck into the highest cutting position.
- Pull the IZT bypass linkages out and into the slots and release so that it is held in the bypass position.
- To reengage the IZT's to drive, reverse the above procedure.

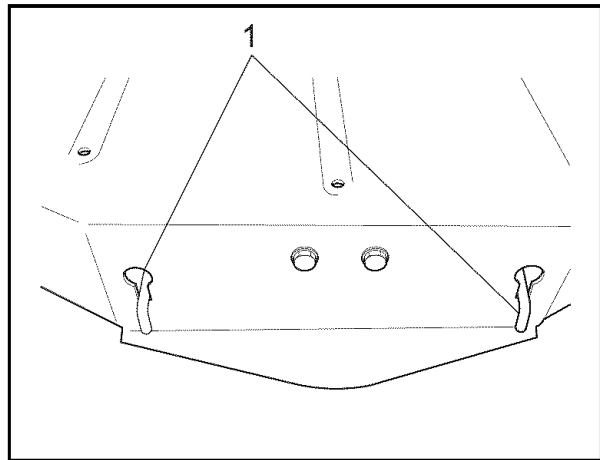

8011-722

1. IZT Bypass linkages

Bypass linkages

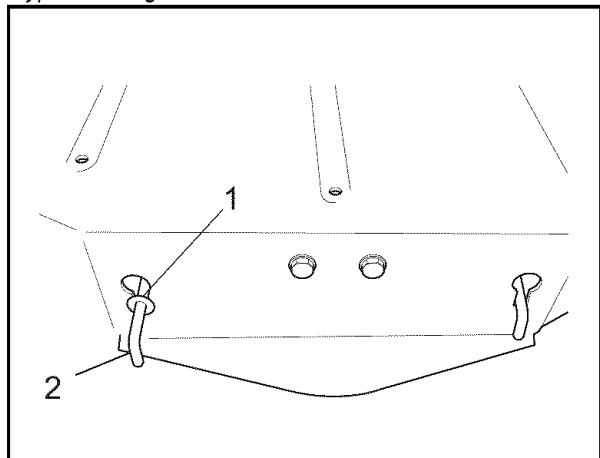

8011-722

1. Head outside of rear deck
2. IZT Bypass linkage in bypass position

Bypass position

MAINTENANCE

Maintenance

Maintenance Schedule

The following is a list of maintenance procedures that must be performed on the machine. For those points not described in this manual, visit an authorized service workshop. An annual service carried out by an authorized service workshop is recommended to maintain your machine in the best possible condition and to ensure safe operation.

Read "Maintenance" in the Safety Instructions section.

● = Described in this manual

○ = Not described in this manual

Maintenance	Page	Daily maintenance		Weekly maintenance	At least once each year	Maintenance interval in hours			
		Before	After			25	50	100	300
Check the parking brake	41	●							
Check the engine's oil level (every refueling)	54	●							
Check outside of air cleaner	39	●							
Check the safety system	38	●							
Check for fuel and oil leakages	-	○							
Check/clean the engine's cooling air intake	39		●						
Check the mower deck	46		●						
Check hardware (screws, nuts, etc.)	50		●						
Clean under the mower deck	50		●						
Start the engine and blades, listen for unusual sounds	-		○						
Check for damage	-		○						
Thoroughly clean around the engine	-		○						
Clean around belts, belt pulleys, etc.	-		○						
Check the tire pressures	41					●			
Check battery	36					●			
Sharpen/Replace mower blades	45					●			
Lubricate the caster wheels	50					●			
Clean the engine's cooling air intake ²⁾	39				●	●			
Clean the air cleaner's pre-filter ²⁾ (foam)	40				●	●			
Clean the air cleaner's filter cartridge ²⁾ (paper filter)	40				●		●		
Check/adjust the parking brake	-				○		○		
Inspect muffler/Spark arrester	-				○		○		

MAINTENANCE

Maintenance	Page	Daily maintenance		Weekly maintenance	At least once each year	Maintenance interval in hours			
		Before	After			25	50	100	300
Check/adjust throttle cable	39							●	
Check the condition of belts, belt pulleys, etc.	42				●			●	
Change the engine oil ¹⁾	52				●		●		
Replace the engine oil filter	54				●			●	
Clean/replace the spark plugs	37				●			●	
Replace the air filter (paper filter) ²⁾	40				●			●	
Check the caster wheels (every 200 hours)	50							●	
Clean the cooling fins ²⁾	-				○			○	
Replace the air cleaner's pre-filter ²⁾ (foam)	40				●				●
Check/adjust the mower deck	46				●				●
Check the engine valve clearance ⁴⁾	-				○				○
Perform the 300-hour service ⁴⁾	70				○				○

¹⁾ First change after 5-8 hours. When operating with a heavy load or at high ambient temperatures, replace every 50 hours. ²⁾ In dusty conditions, cleaning and replacement are required more often. ³⁾ For daily use, the machine should be lubricated twice weekly. ⁴⁾ Performed by authorized service workshop.

● = Described in this manual

○ = Not described in this manual



WARNING!

No adjustments or maintenance to be carried out unless:

- The engine is stopped.
- The ignition key has been removed.
- The parking brake is on.

MAINTENANCE

Battery

Your mower is equipped with a maintenance free battery and does not need servicing. However, periodic charging of the battery with an automotive type battery charger will extend its life.

- Keep battery and terminals clean.
- Keep battery bolts tight.
- Recharge at 6-10 amperes for 1 hour

To clean battery and terminals

Corrosion and dirt on the battery and terminals can cause the battery to "leak" power.

1. Open terminal access doors.
2. Disconnect BLACK battery cable first, then the RED battery cable and remove the battery from the machine.
3. Rinse the battery with plain water and dry.
4. Clean terminals and battery cable ends with wire brush until shiny.
5. Coat terminals with grease or petroleum jelly
6. Reinstall battery.

Replacing battery

1. Lift Seat and rotate forward.
2. Open terminal access doors.
3. Using two 1/2" wrenches disconnect BLACK battery cable then RED battery cable.
4. Using 7/16" wrench, remove terminal guard.
5. Carefully remove the battery from the mower.
6. Install new battery with terminals in the same position as the old battery.
7. Reinstall terminal guard.
8. First connect RED battery cable to positive (+) battery terminal with hex bolt and hex nut.
9. Connect BLACK grounding cable to negative (-) battery terminal with remaining hex bolt and hex nut.
10. Tighten securely.
11. Close terminal access doors.
12. Lower seat.

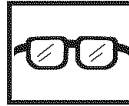

Always use protective glasses when handling the battery.

IMPORTANT INFORMATION

Do not attempt to open or remove caps or covers. Adding or checking level of electrolyte is not necessary.

Always use two wrenches for the terminal screws



WARNING!

Do not short battery terminals by allowing a wrench or any other object to contact both terminals at the same time. Before connecting battery, remove metal bracelets, wristwatch bands, rings, etc.

Positive terminal must be connected first to prevent sparks from accidental grounding.

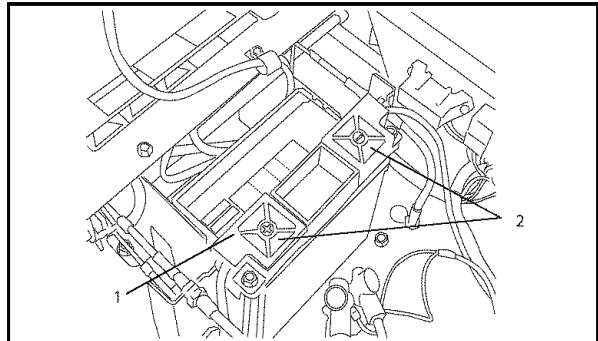

CZ-22

1. Terminal guard
 2. Terminal access doors
- Battery installation*

MAINTENANCE

Ignition System

The engine is equipped with an electronic ignition system. Only the spark plug requires maintenance.

For recommended spark plug, see Technical Data.

1. Remove the ignition cable boot and clean around the spark plug.
2. Remove the spark plug with a spark plug socket wrench.
3. Check the spark plug. Replace the spark plug if fouled, the electrodes are burned and if the insulation is cracked or damaged. Clean the spark plug with a steel brush if it is to be reused.
4. Measure the electrode gap with a gapping tool. The gap should be .030" (0.75 mm). Adjust as necessary by bending the side electrode.
5. Reinsert the spark plug, turning by hand to avoid damaging the threads.
6. After the spark plug is seated, tighten it using a spark plug wrench so that the washer is compressed. A used spark plug should be turned 1/8 of a turn from the seated position. A new spark plug should be turned 1/4 a turn from the seated position.
7. Replace the ignition cable.

IMPORTANT INFORMATION

Fitting the wrong spark plug type can damage the engine.

Inadequately tightened spark plug can cause overheating and damage the engine. Tightening the spark plug too hard can damage the threads in the cylinder head.

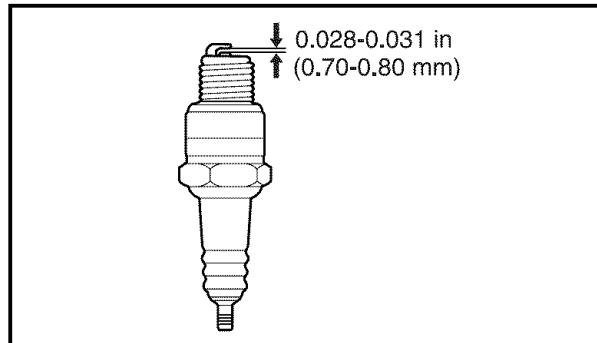

8011-054

Measure the electrode gap

MAINTENANCE

Checking the Safety System

The machine is equipped with a safety system that prevents starting or driving under the following conditions.

The engine can only be started when:

1. The mower deck is disengaged.
2. The steering controls are in the outer, locked neutral position.
3. The driver is sitting in the driver's seat.
4. The parking brake is on.

Make daily inspections to ensure that the safety system works by attempting to start the engine when one of the conditions is not met.

Change the conditions and try again.

If the machine starts when one of these conditions is not met, turn the machine off and repair the safety system before using the machine again.

Make sure the engine stops when the parking brake is not engaged and the operator leaves the seated position.

Check that the engine stops if the mower blades are engaged and the driver temporarily stands up.

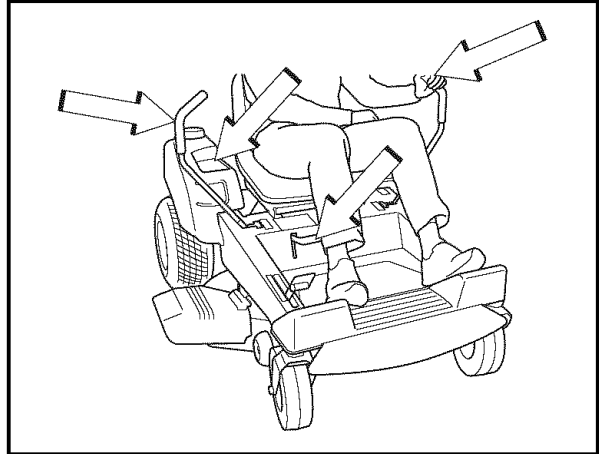

8011-484

Conditions for starting

IMPORTANT INFORMATION

In order to be able to drive, the driver must sit in the seat and release the parking brake before the steering controls can be moved into the neutral position, otherwise the engine will stop.

MAINTENANCE

Checking the Engine's Cooling Air Intake

Check that the engine's cooling air intake is free from leaves, grass, and dirt.

If the cooling air intake is clogged, engine cooling deteriorates, which can lead to engine damage.

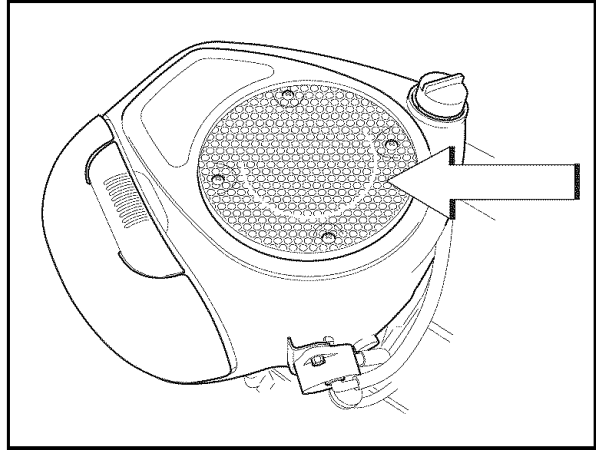

8011-491

Check and clean the cooling air intake

Checking and Adjusting the Throttle Cable

Check that the engine responds to throttle increases and that a good engine speed is attained at full throttle.

If doubts arise, contact the service workshop.

If adjustments are necessary, they can be made as follows for the lower cable:

1. Loosen the clamping screw for the cable's outer casing and move the throttle to the full throttle position (no choke).
2. Check that the throttle cable is mounted in the correct hole in the lever, see illustration.
3. Push the throttle cable's outer casing until choke start position, see illustration, and tighten the clamping screw.
4. Set the throttle control to the choke position and check that full choke is obtained.

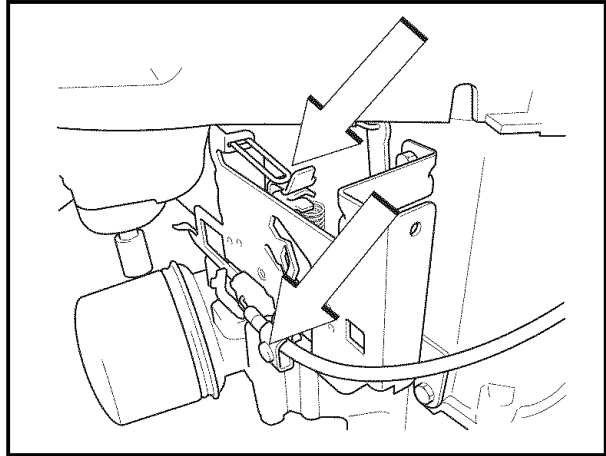

8011-492

Adjusting the throttle cable

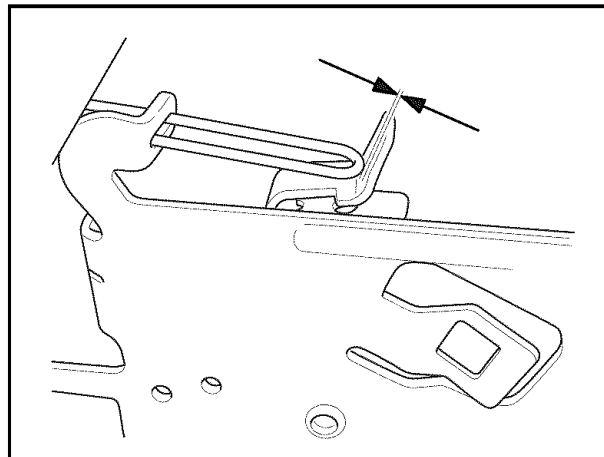

8009-404

Choke start position

MAINTENANCE

Replacing the Air Filter

If the engine seems weak or runs unevenly, the air filter may be clogged. If run with a dirty air filter, the spark plug can become fouled. For this reason, it is important to replace the air filter regularly (see the heading Maintenance Schedule for the proper service interval).

Check the air cleaner daily or before starting the engine. Check for build-up of dirt and debris around the air cleaner system. Keep this area clean. Also check for loose or damaged components. Replace all bent damaged air cleaner components.

Cleaning/replacing the air filter is carried out as follows:

Briggs and Stratton engine

The air filter is replaced as follows:

1. Remove the air filter cowling
2. Remove the filter cartridge.
3. Remove the foam filter (pre-cleaner). Clean the foam filter with liquid detergent and water. Squeeze dry in a clean cloth. Saturate with engine oil and squeeze it inside a clean absorbent cloth.
4. Tap the paper filter against a fixed surface to remove dust. If the paper filter is still dirty, it must be replaced.

IMPORTANT INFORMATION

Do not use compressed air to clean the paper filter.

Filters should not be oiled. They should be assembled dry.

5. Wipe clean the inside of air filter housing.
6. Refit the foam filter (pre filter).
7. Mount the filter in the air filter housing.
8. Replace the cowling over the air filter housing.

IMPORTANT INFORMATION

Please see the manual of the engine manufacturer for any additional instructions, including safety instructions

IMPORTANT INFORMATION

Operating the engine with loose damaged air cleaner components could allow unfiltered air into the engine, causing premature wear and failure.



WARNING!

The engine and the exhaust system, become very hot during operation.

Risk for burns if touched.

Allow engine and exhaust system to cool at least two (2) minutes before refueling.

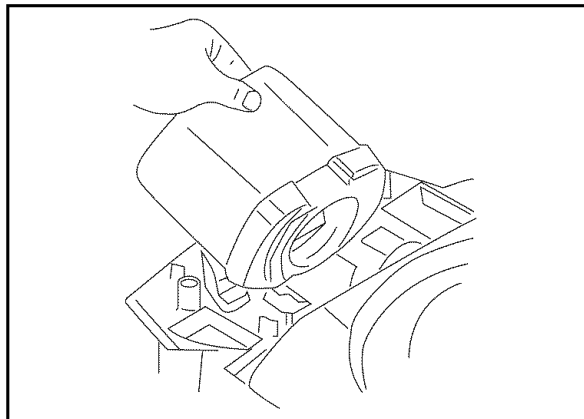

Remove filter

8019-014

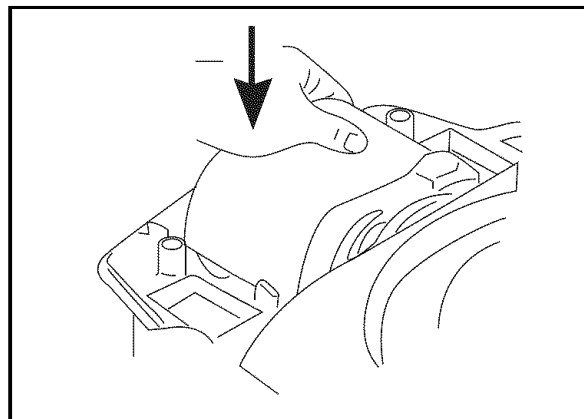

Install filter

8019-015

MAINTENANCE

Replacing the Fuel Filter

Replace the line-mounted fuel filter every 100 hours (once per season) or more regularly if it is clogged.

Replace the filter as follows:

1. Move the hose clamps away from the filter. Use flat-nosed pliers.
2. Pull the filter loose from the hose ends.
3. Push the new filter into the hose ends. Position the filter with the "FLOW" arrow pointing up toward the carburetor. If necessary, a soap solution can be applied to the filter ends to ease mounting.
4. Move the hose clamps back toward the filter.

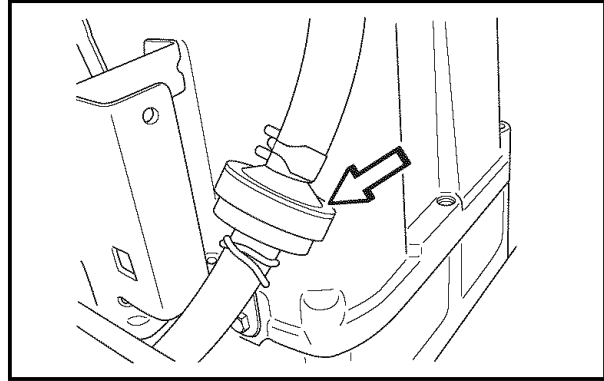

8009-405

Fuel filter

Checking Tire Pressures

All four tires should have a pressure of 15 psi / 103 kPa / 1 bar.

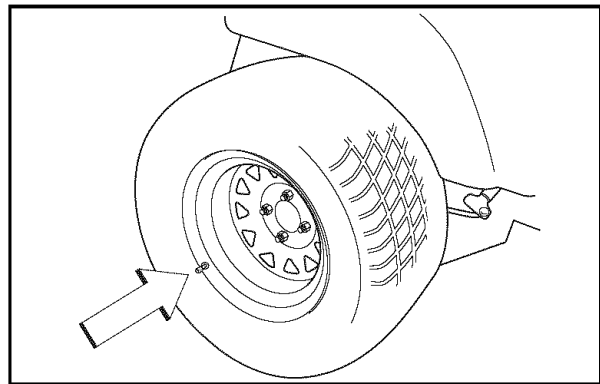

8011-564

Tire pressures

Checking the Parking Brake

Visually check that no damage is found on the lever, linages, or switch belonging to the parking brake. Perform a stand still test and check that there is a braking action.

To adjust the parking brake, contact the Husqvarna service workshop.

IMPORTANT INFORMATION

The parking brake is a mechanical latch brake and must not be applied when the mower is moving.



WARNING!
Faulty adjustment can cause an accident.

MAINTENANCE

Checking the V-belts



WARNING!

No adjustments or maintenance to be carried out unless:

- The engine is stopped.
- The ignition key has been removed.
- The parking brake is on.

Deck belt

V-belts are not adjustable. Replace belts if they begin to slip from wear.

Deck belt removal



WARNING!

Idler arm is spring loaded. Have a tight grip on idler arm or ratchet and release slowly.

- Park on a level surface. Apply parking brake.
- Lower the deck into the lowest cutting position
- Disengage belt tension by pushing inward on deck belt idler pulley by hand or with a 1/2" drive ratchet placed in square drive hole on idler arm. While arm is pushed inward, remove belt from stationary idler pulley and release idler arm slowly until spring force is no longer felt.
- Remove bolt from idler pulley. This will allow belt to pass by the belt guide.
- Loosen screws from both left and right plastic belt shield above each mandrel housing. Remove shields
- Remove any dirt or grass that may have accumulated around the cutter housings and entire deck surface.
- Carefully roll the belt over the top of the cutter housing pulleys.
- Remove the belt from around the electric clutch on the engine shaft.
- The belt can now be removed.

MAINTENANCE

Deck belt installation

NOTE: For ease in installing the deck belt, refer to the routing decal on bottom of seat.

- Wrap the deck belt around the electric clutch pulley that is located on the engine shaft.
- Route the belt forward between the EZT (E-Series Zereturn Transaxles) and up onto the deck.
- Place belt around spring loaded idler pulley, between the pulley and guide. Secure bolt and nut.
- Starting on the right hand side of the deck, wrap the belt around the stationary idler pulley, the right mandrel housing, then around to the left mandrel housing.
- Push inward on the idler arm and carefully route belt over stationary idler pulley. Once belt is properly routed, slowly release idler arm to tension belt.
- Double check belt routing to make sure it matches the routing decal, and the belt does not have any twist. Correct as needed.
- Replace belt shields on both mandrel housings and secure with fasteners.

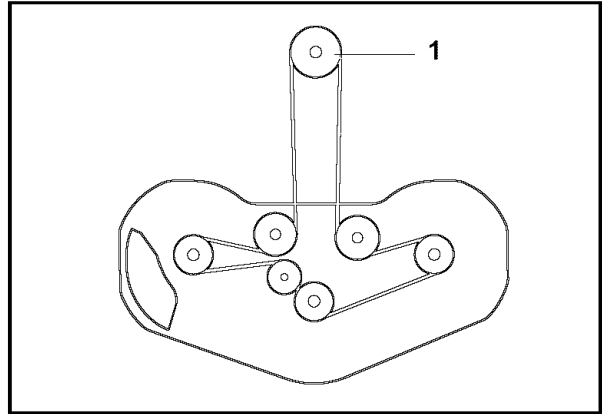

1. Clutch pulley

Belt routing, deck belt

MAINTENANCE

EZT belt

To replace EZT (E-Series Zeroturn Transaxle) belt

Park the mower on a level surface. Engage the parking brake.

EZT belt removal

NOTE: Be careful not to damage the fan blades on the EZT's as this can affect cooling or damage the EZT's

- Remove the deck belt (see to replace deck belt in this section of the manual).
- Unplug clutch from wiring harness. Remove bolt from center of clutch and slide clutch off of engine shaft.
- Create slack in the belt by removing the spring on the pump idler arm.
- The belt should now be able to be removed from the engine pulley and EZT pulleys.

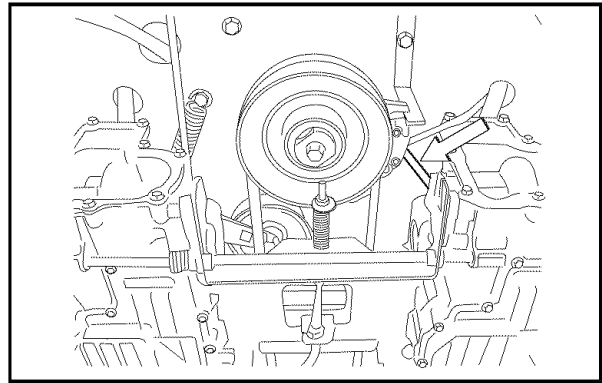

Transaxle belt

Belt installation

- Wrap the EZT belt around the EZT pulleys
- Route the belt around the inside of the idler pulley.
- Now you can wrap the belt around the engine pulley.
- Reattach the spring on the pump idler arm.
- Install clutch on to engine shaft (pulley side down) make sure key is installed and align the clutch anti rotation tab into slot on clutch. Secure clutch, install wire.
- Reinstall the deck belt onto the electric clutch belt (see to replace deck belt in this section of the manual).

MAINTENANCE

Checking the Blades

In order to attain the best mowing effect, it is important that the blades are well sharpened and not damaged.

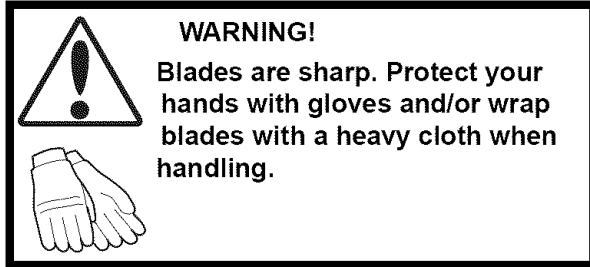

Bent or cracked blades or blades with large nicks should be replaced.

Check the blade mounts.

IMPORTANT INFORMATION

The sharpening of blades should be carried out by an authorized service workshop.

Damaged blades should be replaced when hitting obstacles that result in a breakdown. Let the service workshop decide whether the blade can be repaired/ground or must be replaced.

Blade replacement:

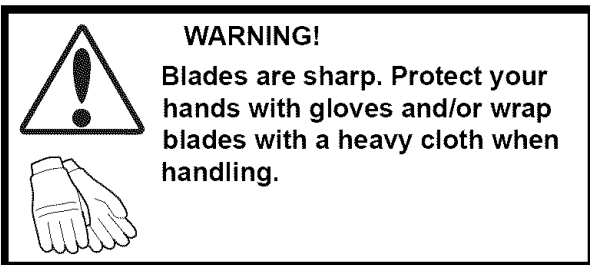

- Remove blade bolt by turning counterclockwise.

IMPORTANT INFORMATION

To ensure proper assembly, center hole in blade must align with star on cutter housing.

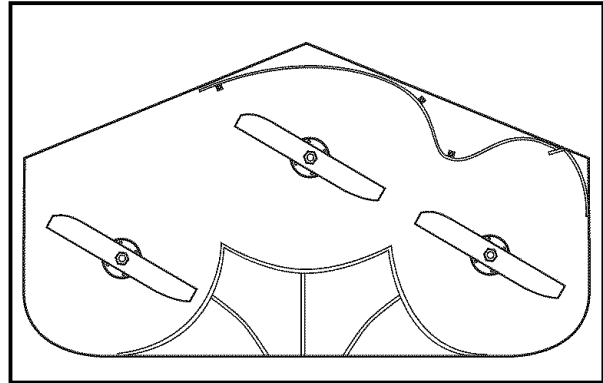

8011-604

Check the blades

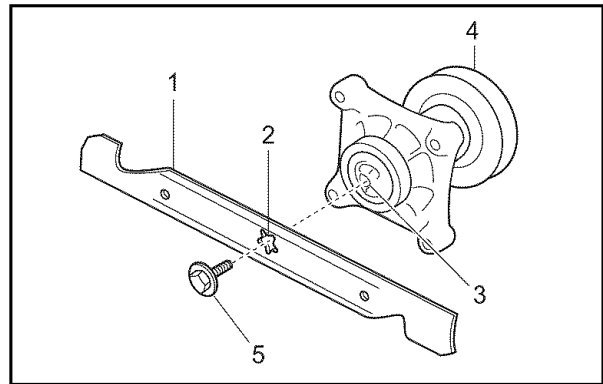

8011-671

1. Blade
2. Center hole
3. Star
4. Cutter housing
5. Blade bolt (special)

Blade attachment

MAINTENANCE

- Install new or re-sharpened blade with stamped "GRASS SIDE" facing towards ground/grass (down) or "THIS SIDE UP" facing deck and cutter housing.
- Install and tighten blade bolt securely.
Torque blade bolt to 27-35 ft/lb (35-45 Nm).

IMPORTANT INFORMATION

Special blade bolt is heat treated.
Replace with a Husqvarna bolt if required.
Do not use lower grade hardware than specified.

Adjusting the Mower Deck



WARNING!

Before performing any service or adjustment checklist:

1. Engage the parking brake.
2. Place the Blade-switch in the disengaged position.
3. Turn ignition switch to "OFF" position and remove the key.
4. Make sure the blades and all moving parts have completely stopped.
5. Disconnect the spark plug wire from all spark plugs and place the wire where it cannot come in contact with the plug.



WARNING!

Blades are sharp. Protect your hands with gloves and/or wrap blades with a heavy cloth when handling.



Check the tire pressure before adjustment of the mower deck, see "Checking Tire Pressure" in Maintenance section.

Faulty mower deck adjustment will cause an uneven mowing result.

MAINTENANCE

To level deck

Adjust the deck while the mower is on a level surface. Make sure the tires are inflated to the correct pressure. See "Technical Data" under Transmission. If tires are under or over inflated, you can not properly adjust your deck.

NOTE: It may be easier to adjust the front lift linkages by removing the floor pan before any adjustments are made.

Side-to-side adjustment

1. Raise the deck into the four inch 4" (102 mm) cutting position.
2. Measure height from the bottom edge of the deck to the ground at both front corners. Distance "A" should be the same, or within 3/16" (5 mm) of an inch.
3. If adjustment is necessary, make adjustment to one side of the deck only

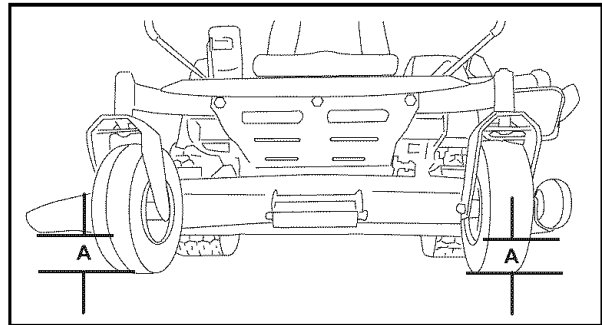

CZ-16

Distances A

4. Remove the securing ring from the top pin and the bottom clevis pin. Push bottom clevis pin through deck lift connector while supporting deck. Adjust by moving the deck lift connector to a new hole to lower or raise that specific corner of the deck. The round hole closest to the long slot is the shorter length and will raise the deck, the round hole farthest away from the long slot is the longer of the two and would lower the deck when used.
5. Recheck measurements after adjustment.

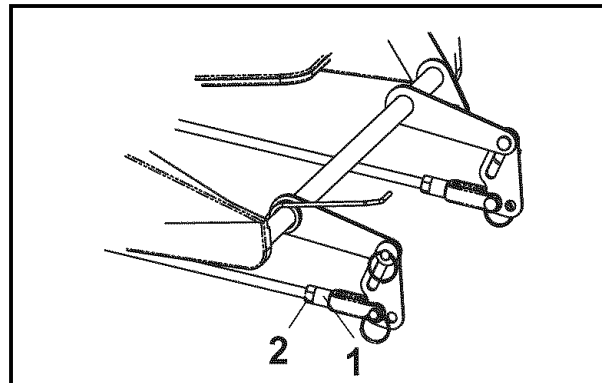

8011-645

1. Front lift linkage

2. Hex nut

Adjustment A

MAINTENANCE

Front-to-back adjustment

IMPORTANT INFORMATION

Deck must be leveled side-to-side, prior to leveling front to back. If the following front to back adjustment is required, be sure to adjust both front and rear linkages equally so the deck will stay level side to side.

To obtain the best cutting performance, the deck should be adjusted so the front tip of the blades are approximately 1/8" (3.2 mm) to 1/4" (6.5 mm) lower than the rear tip. If the front tip is higher, this will create a poor quality of cut.

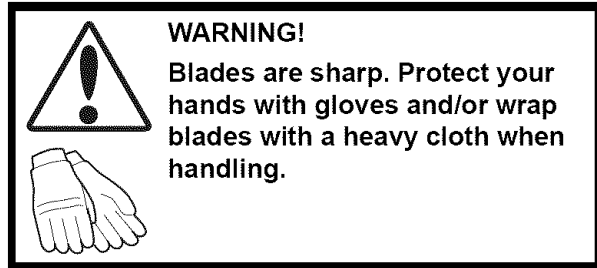

1. Check blade height with blade facing front to rear. Measure distance "B" at the front and rear tip of the blade.
2. Before making any necessary adjustments, check to make sure that the deck is level side-to-side. See "Side to Side Adjustment" in Maintenance section.
3. With the deck in the 4" (100 mm) cutting position, measure the front and rear tip of each blade while facing front to rear.
4. To adjust, loosen the jam nut on the yoke, remove the securing ring and push the clevis pin out while supporting the deck. To lower that specific corner, lengthen the rod assembly by turning the yoke counter clockwise. To raise that specific corner, shorten the rod assembly by turning the yoke clockwise.
5. Reinstall clevis pin and recheck dimension.
6. Once front to back adjustment is correct, reinstall securing rings and secure jam nuts.

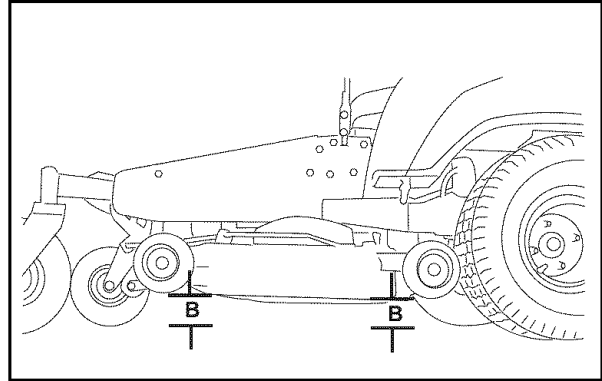

CZ-19

Front to back adjustment

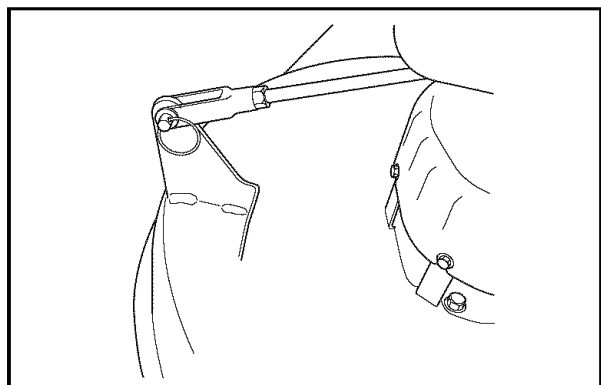

8011-497

Rear lift linkage

MAINTENANCE

To adjust anti-scalp rollers

Deck has anti-scalp rollers.

Anti-scalp rollers are properly adjusted when they are just slightly off of the ground when the deck is at the desired cutting height in the operating position. Anti-scalp rollers then keep the deck in the proper position to help prevent scalping in most terrain conditions.

IMPORTANT INFORMATION

Adjust Anti-scalp rollers with the mower on a flat level surface.

1. Adjust the deck to the desired cutting height (see "TO ADJUST DECK CUTTING HEIGHT" in the operation section of this manual).
2. Using a 3/4" wrench and a 9/16" wrench, remove the nut and shoulder bolt from the anti-scalp roller.
3. Lower the anti-scalp roller to the ground, and raise it up to the next highest hole.
4. Replace and tighten the nut and shoulder bolt.
5. Be sure to adjust all of the anti-scalp rollers to the same position.
6. Be sure to readjust the anti-scalp rollers if the cutting height is changed.

IMPORTANT INFORMATION

The anti-scalp rollers must not be used for gauge wheels or the roller and deck may be damaged.

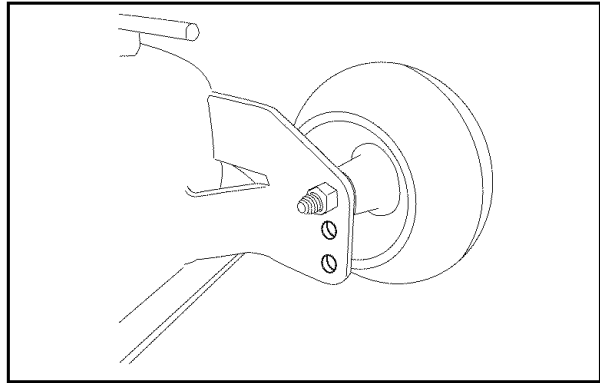

CZ-9

Anti-scalp roller

MAINTENANCE

Cleaning and Washing

Regular cleaning and washing, especially under the mower deck, will increase the machine's lifespan. Make it a habit to clean the machine directly after use (after it is cooled), before the dirt sticks.

Do not spray water on the top of the mower deck. Use compressed air to clean the top side of mower deck. Regularly clean deck and underside of deck, avoid spraying engine and electrical components with water.

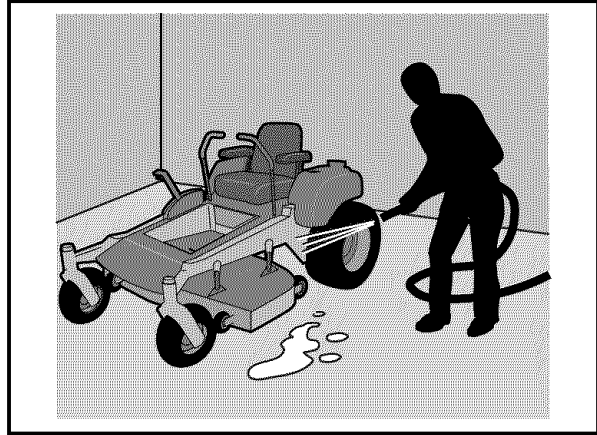

8011-644

Cleaning



Use protective glasses when cleaning and washing.

Caster Wheels

Check every 200 hours. Lift front of unit off of ground so caster wheels can rotate freely. Tighten caster bolt then back off 1/2 turn. Check that wheel rotates freely. If wheel does not rotate freely back the caster bolt off in 1/4 turn increments until wheel rotates freely.

IMPORTANT INFORMATION

DO NOT add any type of tire liner or foam fill material to the tires. Excessive loads created by foam filled tires will cause premature failures.

Only use O.E.M. specified tires.

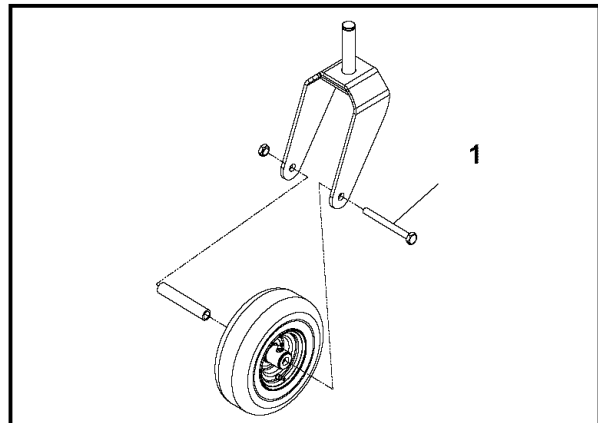

1. Caster bolt

Caster wheels

8011-619

Foam filled tires or solid tires will void the warranty.

Hardware

Check daily. Inspect the entire machine for loose or missing hardware.

LUBRICATION

Lubrication

Lubrication Schedule

12/12	1/52	1/365	Z	25h	50h	100h	200h	300h
				1 ← (2x)				
⚠	👁	2		2	⚠			
🗑		3		3		🗑		

8011-673

Lubrication schedule

12/12 Every year

1/52 Every Week

1/365 Every day

Lubricate with grease gun ←

Oil change ⚠

Filter change 🗑

🗑 Lubricate with oil can

👁 Level check

General

Remove the ignition key to prevent unintentional movements during lubrication.

When lubricating with an oil can, it must be filled with engine oil.

When lubricating with grease, unless otherwise stated, use a high grade molybdenum disulfide grease.

For daily use, the machine shall be lubricated twice weekly.

Wipe away excess grease after lubrication.

It is important to avoid getting lubricant on the belts or the drive surfaces on the belt pulleys. Should this happen, attempt to clean them with spirits. If the belt continues to slip after cleaning, it must be replaced. Gasoline or other petroleum products must not be used to clean belts.

LUBRICATION

Lubricating the Cables

If possible, grease both ends of the cables and move the controls to end stop positions when lubricating. Refit the rubber covers on the cables after lubrication. Cables with sheaths will bind if they are not lubricated regularly. If a cable binds, it can disrupt operation.

If a cable binds, remove the cable and hang it vertically. Lubricate it with light engine oil until the oil begins to escape from the bottom.

Tip: Fill a small plastic bag with oil and tape it so that it seals against the sheath and allow the cable to hang vertically from the bag overnight. If you do not succeed in lubricating the cable, it must be replaced.

Lubricating in Accordance with the Lubrication Schedule

1. Caster wheels

Lubricate with a grease gun. One zerk for each bearing, two strokes. Use only good quality grease. See General in Lubrication.

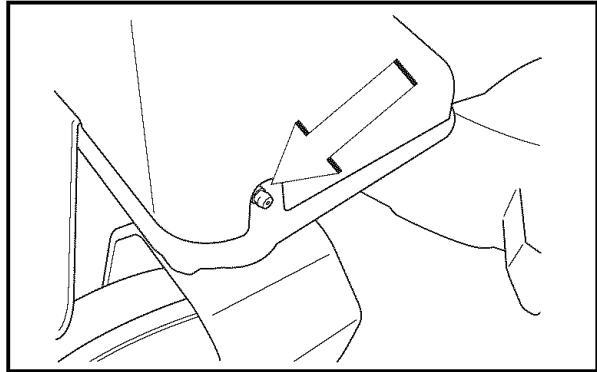

8011-717

Caster wheel zerk

2. Engine Oil (Briggs & Stratton)

Changing the Engine Oil

The engine oil should be changed for the first time after 5-8 hours of operation. Thereafter, it shall be changed every 50 hours.



WARNING!

Engine oil can be very hot if it is drained directly after stopping the engine. Allow the engine to cool somewhat first.

LUBRICATION

1. Place the machine on a flat surface.
2. Remove the yellow cap and fit a hose to the drain valve.

IMPORTANT INFORMATION

Used engine oil is a health hazard and must not be disposed of on the ground or in nature; it should always be disposed of at a workshop or appropriate disposal location.

Avoid skin contact; wash with soap and water in case of spills.

3. Place a container under the engine where the hose from the oil drain valve exits.
4. Remove the dipstick and open the drain valve by turning and pulling out the black sleeve.
5. Allow the oil to run out into the container.
6. Then close the oil drain valve.
7. Remove hose and install the yellow cap. The cap must be installed to stop flow if the valve is opened by mistake.
8. Replace the oil filter if necessary.
9. Fill with new engine oil in accordance with Checking the Oil Level.
10. Start the engine. Run it for a few seconds. Stop and re-check the oil level.

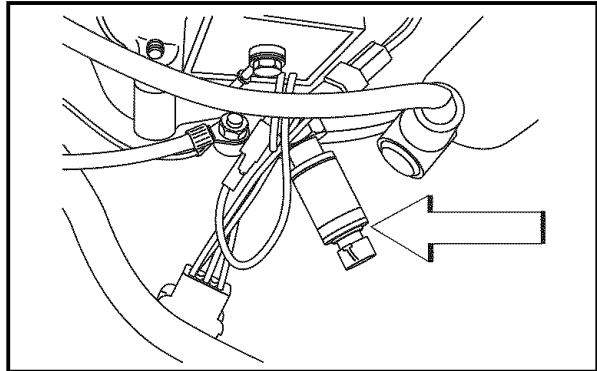

8011-499

Oil drain valve

LUBRICATION

Checking the oil level

Check the oil level in the engine when the machine is standing level and the engine is stopped.

Remove the dipstick, wipe it clean, and then replace it.

The dipstick should be screwed into place.

Take the dipstick out again and read the oil level.

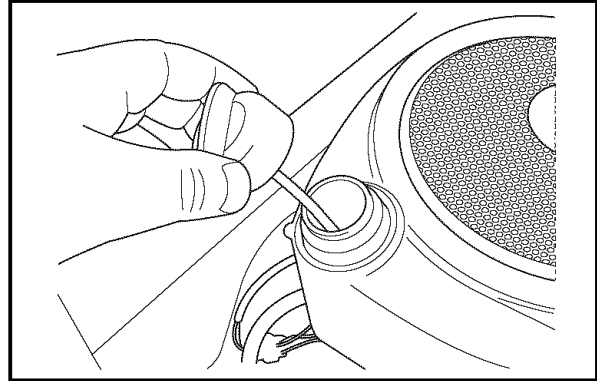

8011-500

Remove the dipstick

The oil level shall lie between the markings on the dipstick. If the level is approaching the "ADD" mark, fill the oil to the "FULL" mark on the dipstick.

Never fill above the "FULL" mark.

The oil is filled through the hole for the dipstick.

API class SF, SG, SH, SJ or higher must be used

Synthetic oil SAE 5W-30 or 10W30 is recommended at all temperatures.

Mineral oil SAE 5W-30, 10W30 can be used between 0 °F/-18 °C and 40 °F/+5 °C. At temperature above 40 °F/+5 °C single grade SAE 30 must be used.

The engine holds 1.5 quarts (1.4 liters) of oil excluding the filter; including the filter 1.6 quarts (1.5 liters).

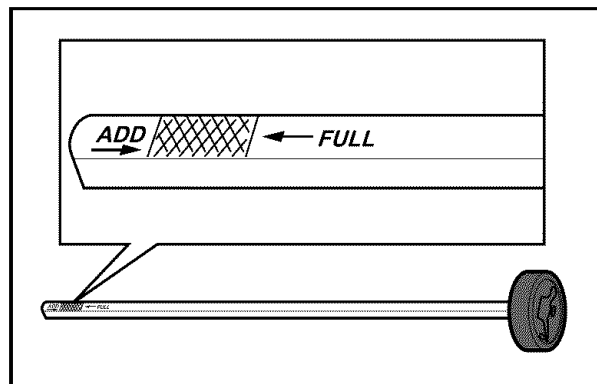

8009-159

The dipstick markings

2. Changing the Oil Filter

1. Drain the engine oil following the procedure described in Engine Oil/Change Engine Oil section.
2. Remove the oil filter. If necessary, use a filter remover.
3. Wipe new, clean engine oil on the seal of the new filter.
4. Mount the filter by hand with + 3/4 turn.
5. Run the engine warm, then check that there are no leaks around the oil filter seal.

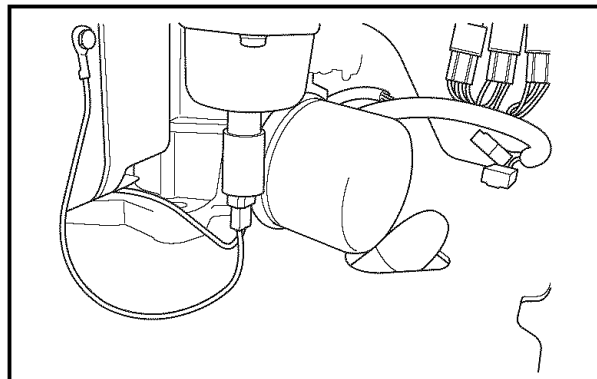

8011-707

Changing the oil filter Briggs & Stratton

LUBRICATION

6. Check the oil level in the engine, fill if necessary. The oil filter holds 0.1 liters of oil.

Transmission

The transmission is maintenance free. There is no need for level checks or oil changes. If a leak occurs, replace the unit or contact your Husqvarna dealer.

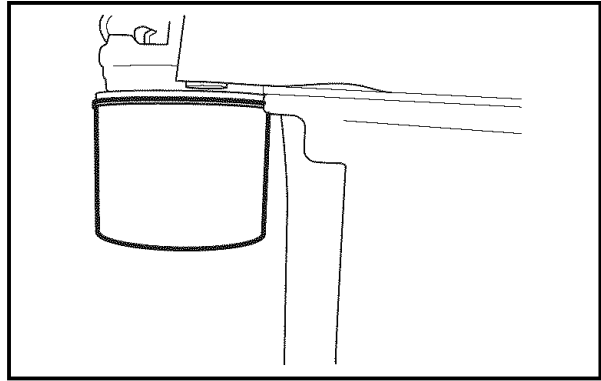

8011-739

Changing the oil filter Kohler

TROUBLE SHOOTING GUIDE

Trouble Shooting Guide

Problem	Cause
The engine will not start.	<ul style="list-style-type: none">• The blade switch is engaged.• The steering controls are not locked in the neutral position.• The driver is not sitting in the driver's seat.• The parking brake is not activated.• The battery is dead.• Contamination in the carburetor or fuel line.• The fuel supply is closed or the tap for the fuel tanks is in the wrong position.• Clogged fuel filter or fuel line.
The starter motor does not turn the engine over.	<ul style="list-style-type: none">• Dead battery.• Poor contacts on the battery terminal cable connections.• Fuse blown.• Ignition system faulty.• Fault in the starter motor safety circuit. See Checking the Safety System in the Maintenance section.
The engine runs rough.	<ul style="list-style-type: none">• Faulty carburetor.• The choke control is pulled out with a warm engine.• Defective valves.• Defective piston, cylinder, piston ring, or cylinder head seal.• The cylinder head bolts are loose.• Clogged fuel filter or jet.• Clogged ventilation valve on the fuel cap.• Fuel tank nearly empty.• Defective spark plug.• The spark plug is loose.• Defective ignition cable.• Defective spark plug electrode.• Defective spark plug connection.• Rich fuel mixture or fuel-air mixture.

TROUBLE SHOOTING GUIDE

- Wrong fuel type.
- Water in the fuel.
- Clogged air filter.

The engine seems weak.

- Clogged air filter.
- Defective spark plug.
- Carburetor incorrectly adjusted.

The engine overheats.

- Clogged air intake or cooling fins.
- Engine overloaded.
- Poor ventilation around engine.
- Defective engine speed regulator.
- Soot in the combustion chamber.
- Too little or no oil in the engine.
- Defective spark plug.
- Pre-ignition incorrect.

Battery not charging.

- Poor contact with battery terminal cable connectors.

The machine moves slowly, unevenly, or not at all.

- Parking brake on.
- Bypass valve on pump open.
- Drive belt for the transmission gears slack or has come off.

Mower deck not engaging.

- Drive belt for the mower deck has come loose.
 - Contact for the electromagnetic coupling has loosened.
 - The blade switch is faulty or has come loose from the cable contact.
 - The fuse has blown.
-

TROUBLE SHOOTING GUIDE

Uneven mowing results.

- Different air pressure in the tires on the left and right sides.
- Bent blades.
- The suspending for the mower deck is uneven.
- The blades are blunt.
- Driving speed too high.
- The grass is too long.
- Grass collected under the mower deck.

The machine vibrates.

- The blades are loose.
 - The blades are incorrectly balanced.
 - The engine is loose.
-

STORAGE

Storage

Winter Storage

At the end of the mowing season, the machine should be readied for storage (or if it will not be in use for longer than 30 days). Fuel allowed to stand for long periods of time (30 days or more) can leave sticky residues that can foul the carburetor and disrupt engine function.

Fuel stabilizers are an acceptable option as regards to the sticky residues that can occur during storage.

Add stabilizer to the fuel in the tank or in the storage container. Always use the mixing ratios specified by the manufacturer of the stabilizer. Run the engine for at least 10 minutes after adding the stabilizer so that it reaches the carburetor. Do not empty the fuel tank and the carburetor if you have added stabilizer.



WARNING!

Never store an engine with fuel in the tank indoors or in poorly ventilated spaces where fuel vapor can come in contact with open flames, sparks, or a pilot light such as in a boiler, hot water tank, clothes drier, etc. Handle the fuel with care. It is very flammable and careless use can cause serious personal injury and property damage. Drain the fuel into an approved container outdoors and far away from open flame. Never use gasoline for cleaning. Use a degreaser and warm water instead.

To ready the machine for storage, follow these steps:

1. Thoroughly clean the machine, especially under the mower deck. Touch up damage to the paint and spray a thin layer of oil on the underside of the mower deck to avoid corrosion.
2. Inspect the machine for worn or damaged parts and tighten any nuts or screws that may have become loose.
3. Change the engine oil; dispose of properly.
4. Empty the fuel tanks or add a fuel stabilizer. Start the engine and allow it to run until the carburetor is drained of fuel or the stabilizer has reached the carburetor.
5. Remove the spark plug and pour about a tablespoon of engine oil into the cylinder. Turn over the engine so that the oil is evenly distributed and then refit the spark plug.
6. Lubricate all grease zerks, joints, and axles.
7. Remove the battery. Clean, charge, and store the battery in a cool place, but protect it from direct cold.
8. Store the machine in a clean, dry place and cover it for extra protection.

Service

When ordering spare parts, please specify the purchase year, model, type, and serial number.

Always use genuine Husqvarna spare parts.

An annual check-up at an authorized service workshop is a good way to ensure that your machine performs its best the following season.

WIRING DIAGRAMS

Wiring diagram

- 6. Seat unoccupied
- 11. Brake switch OFF pos.
- 8. Blade switch in OFF position
- 14-15. Motion control levers OUT

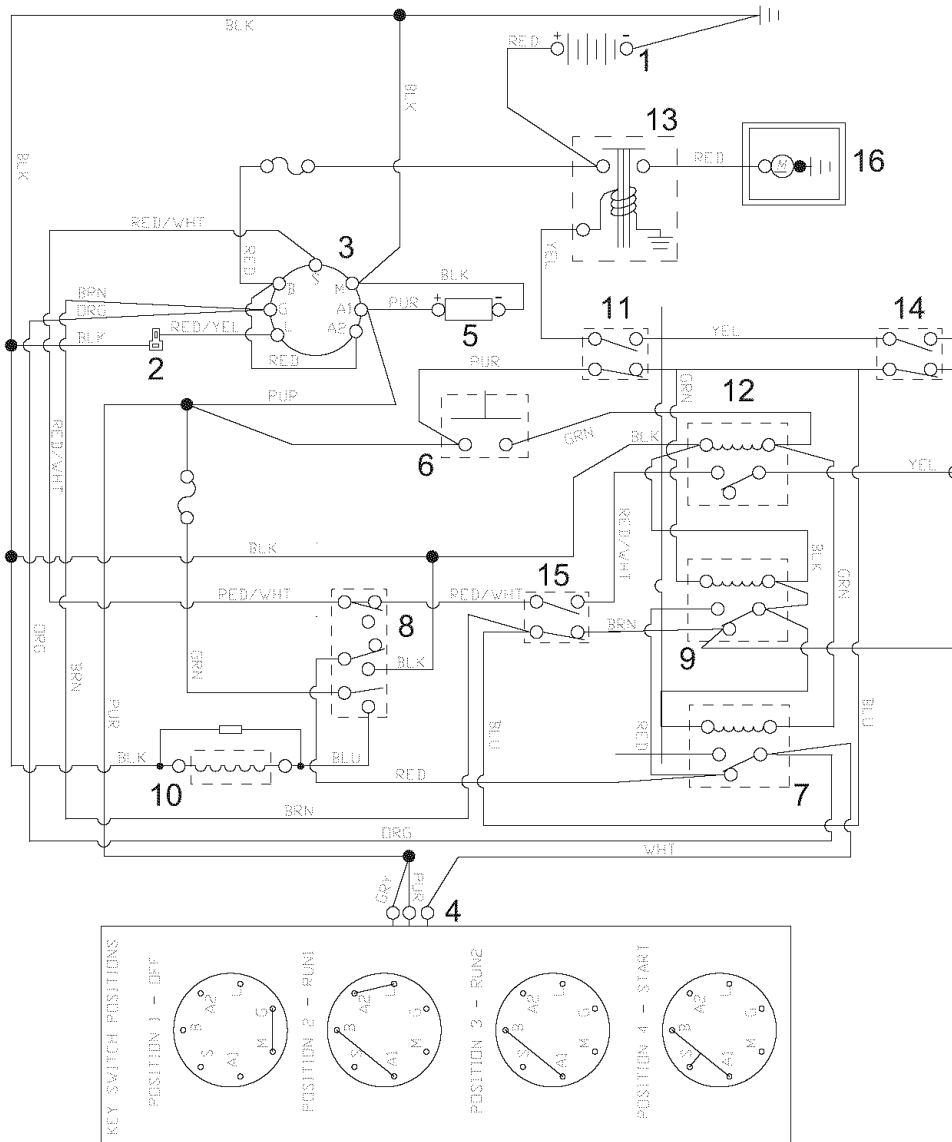

- 1. Battery
- 2. Accessory outlet
- 3. Key switch
- 4. To engine pigtail
- 5. Hour meter
- 6. Seat switch
- 7. Run relay
- 8. Blade switch
- 9. Brake relay
- 10. Electric clutch
- 11. Brake switch
- 12. Start relay
- 13. Starter solenoid
- 14. Left motion control lever
- 15. Right motion control lever
- 16. Starter

- BLK = Black
- BLU = Blue
- BRN = Brown
- GRN = Green
- GRY = Grey
- LT.BLU = Light Blue
- ORG = Orange
- PUR = Purple
- RED = Red
- WHT = White
- YEL = Yellow
- NO = Normally Open
- NC = Normally Closed
- COM = Common

8011-650

TECHNICAL DATA

Technical Data

	Z4218	Z4219
Engine		
Manufacturer	Kohler	Briggs and Stratton
Type	Courage	Intek Single
Power	18 hp / 13.4kW	19 hp / 14.2kW
Lubrication	Pressure with oil filter	
Oil capacity excl filter	1.6 qt / 1.5 liter	1.5 qt / 1.4 liter
Oil capacity incl filter	1.7 qt / 1.6 liter	1.6 qt / 1.5 liter
Engine oil (See viscosity digram)	SAE 10W30, 5W20, 5W30 API SF-SJ	SAE 5W30, 10W30 Synt. SAE 30 Mineral API SF-SJ
Fuel	Min 85 octane unleaded (Max methanol 0%, max ethanol 10%, Max MTBE 15%)	Min 85 octane unleaded (Max methanol 0%, max ethanol 10%, Max MTBE 15%)
Fuel tank capacity	3 gallon / 11.4 liters	3 gallon / 11.4 liters
Spark plugs / gap	Champion RC12YC .030" / 0.75 mm	Champion RC12YC .030" / 0.75 mm
Cooling	Air cooled	Air cooled
Air filter	Standard	Standard
Alternator	12V	12 V 9 A
Starter	Electric	Electric
Transmission		
Transmission	Hydrostatic transaxles	
Speed and direction controls	Dual levers, foam gripped	
Speed forward	0-6 mph / 0-9.7 km/h	0-6 mph / 0-9.7 km/h
Speed reverse	0-3.5 mph / 0-5.6 km/h	0-3.5 mph / 0-5.6 km/h
Brakes	Mechanical parking brake	
Front caster tires, Smooth tread	11x3.5-5, 4 ply	11x3.5-5, 4 ply
Rear tires, Turf pneumatic	18x9.5-8	18x9.5-8
Tire pressure, front and rear	15 PSI / 103 kPa / 1 bar	15 PSI / 103 kPa / 1 bar

TECHNICAL DATA

	Z4218	Z4219
Equipment		
Cutting width	42" / 107cm	42" / 107cm
Cutting height	1.5"- 4" / 3.8 - 10.2 cm	1.5"- 4" / 3.8 - 10.2 cm
Uncut circle	0	0
Number of blades	2	2
Blade length	21" / 533 mm	21" / 533 mm
Nose rollers	No	No
Sprung standard seat	Standard	Standard
Hinged armrests	No	No
Hour meter	Standard	Standard
Blade engagement	85 ft/lb Warner	85 ft/lb Warner
Deck construction	12 gauge, stamped steel	12 gauge, stamped steel
Productivity		
Productivity	2.6 acres /h 10530 m ² /h	2.6 acres /h 10530 m ² /h
Overall dimensions		
Weight	485 lbs /220 kg	485 lbs /220 kg
Base machine length	72" / 183 cm	72" / 183 cm
Base machine width	43" / 109 cm	43" / 109 cm
Base machine height	41" / 104 cm	41" / 104 cm
Overall width, Chute up	43" / 109 cm	43" / 109 cm
Overall width, Chute down	52" / 132 cm	52" / 132 cm

TECHNICAL DATA

	Z4824	Z5426
Engine		
Manufacturer	Briggs and Stratton	Briggs and Stratton
Type	Intek single	ELS twin
Power	24 hp / 17.65kW	26 hp / 19.4kW
Lubrication	Pressure with oil filter	
Oil capacity excl filter	1.5 qt / 1.4 liter	1.5 qt / 1.4 liter
Oil capacity incl filter	1.6 qt / 1.5 liter	1.6 qt / 1.5 liter
Engine oil (See viscosity digram)	SAE 5W30, 10W30 Synt. SAE 30 Mineral API SF-SJ	SAE 5W30, 10W30 Synt. SAE 30 Mineral API SF-SJ
Fuel	Min 85 octane unleaded (Max methanol 0%, max ethanol 10%, Max MTBE 15%)	Min 85 octane unleaded (Max methanol 0%, max ethanol 10%, Max MTBE 15%)
Fuel tank capacity	3 gallon / 11.4 liters	3 gallon / 11.4 liters
Spark plugs / gap	Champion RC12YC .030" / 0.75 mm	Champion RC12YC .030" / 0.75 mm
Cooling	Air cooled	Air cooled
Air filter	Standard	Standard
Alternator	12 V 9 A	12 V 9 A
Starter	Electric	Electric
Transmission		
Transmission	Hydrostatic transaxles	
Speed and direction controls	Dual levers, foam gripped	
Speed forward	0-6 mph / 0-9.7 km/h	0-6 mph / 0-9.7 km/h
Speed reverse	0-3.5 mph / 0-5.6 km/h	0-3.5 mph / 0-5.6 km/h
Brakes	Mechanical parking brake	
Front caster tires, Smooth tread	11x3.5-5, 4 ply	11x3.5-5, 4 ply
Rear tires, Turf pneumatic	18x9.5-8	18x9.5-8
Tire pressure, front and rear	15 PSI / 103 kPa / 1 bar	15 PSI / 103 kPa / 1 bar

TECHNICAL DATA

	Z4824	Z5426
Equipment		
Cutting width	48" / 122cm	54" / 122cm
Cutting height	1.5"- 4" / 3.8 - 10.2 cm	
Uncut circle	0	0
Number of blades	3	3
Blade length	16 1/2" / 419mm	
Nose rollers	Yes	Yes
Sprung standard seat	Standard	Standard
Hinged armrests	No	No
Hour meter	Standard	Standard
Blade engagement	85 ft/lb Warner	85 ft/lb Warner
Deck construction	12 gauge, stamped steel	10 gauge, stamped steel
Productivity		
Productivity	2.6 acres/h 10530 m ² /h	
Overall dimensions		
Weight	580 lbs / 263 kg	605 lbs / 274 kg
Base machine length	72" / 183 cm	72" / 183 cm
Base machine width	50" / 127 cm	50" / 127 cm
Base machine height	41" / 104 cm	41" / 104 cm
Overall width, Chute up	50" / 127 cm	56" / 142 cm
Overall width, Chute down	59" / 150 cm	69" / 175 cm

TECHNICAL DATA

Accessories

Head lights
BioClip attachment (Mulch clip)
Collection system

Torque Specifications

· Engine crankshaft bolt	50 ft/lb (67 Nm)
· Deck pulley bolts	45 ft/lb (61 Nm)
· Lug nuts	75 ft/lb (100 Nm)
· Blade bolt	27-35 ft/lb (35-45 Nm)
· Standard 1/4" fasteners	9 ft/lb (12 Nm)
· Standard 5/16" fasteners	18 ft/lb (25 Nm)
· Standard 3/8" fasteners	33 ft/lb (44 Nm)
· Standard 7/16" fasteners	52 ft/lb (70 Nm)
· Standard 1/2" fasteners	80 ft/lb (110 Nm)

When this product is worn out and no longer used, it shall be returned to the reseller or other party for recycling.

In order to implement improvements, specifications and designs can be altered without prior notification.

Note that no legal demands can be placed based on the information contained in these instructions.

Use only original parts for repairs. The use of other parts voids the warranty.

Do not modify or install non-standard equipment to the unit without consent from the manufacturer. Modifications to the unit may cause unsafe operation or damage the unit.

CONFORMITY CERTIFICATES

Conformity Certificates

USA requirements

Labels are placed on the engine and/or in the engine compartment stating that the machine will fulfill the requirements. This is also applicable to special requirements for any of the states, (Californian emission rules etc.). Do not remove any of these labels. Certificates can also be supplied with the machine at delivery or written in the Engine manual. Take care of them as valuable documents.

SERVICE JOURNAL

Service Journal

Action	Date, mtr reading, stamp, sign
Delivery Service	
1. Charge the battery.	<input type="checkbox"/>
2. Adjust the tire pressure of all wheels to 1 bar (15 PSI).	<input type="checkbox"/>
3. Mount the steering controls in the normal position.	<input type="checkbox"/>
4. Connect the to the cables for the seat's safety switch.	<input type="checkbox"/>
5. Check that the right amount of oil is in the engine.	<input type="checkbox"/>
6. Adjust the position of the steering controls.	<input type="checkbox"/>
7. Fill with fuel.	<input type="checkbox"/>
8. Start the engine.	<input type="checkbox"/>
9. Check that there is drive to both wheels.	<input type="checkbox"/>
10. Check the mower deck adjustment.	<input type="checkbox"/>
11. Check:	
The safety switch for the parking brake.	<input type="checkbox"/>
The safety switch for the mower deck.	<input type="checkbox"/>
The safety switch in the seat.	<input type="checkbox"/>
The safety switch in the steering controls.	<input type="checkbox"/>
Parking brake functionality.	<input type="checkbox"/>
Driving forward.	<input type="checkbox"/>
Driving backward.	<input type="checkbox"/>
Engaging the blades.	<input type="checkbox"/>
12. Check the idle speed.	<input type="checkbox"/>
13. Check the engine high idle speed.	<input type="checkbox"/>
14. Inform the customer about:	
The need and advantages of following the service schedule.	Delivery service has been carried out.
The need and advantages of leaving the machine for service every 300 hours.	No remaining notes.
The effects of service and maintaining a service journal on the machine's resale value.	Certified:
Application areas for Mulching.	
15. Fill in the sales papers, etc.	

SERVICE JOURNAL

After the First 5-8 Hours

1. Change engine oil.

SERVICE JOURNAL

Action	Date, mtr reading, stamp, sign
<p>25-Hour Service</p> <ol style="list-style-type: none">1. Sharpen/Replace mower blades if required.2. Lubricate the caster wheels.3. Check the tire pressures.4. Check battery with cables.5. Check/clean the engine's cooling air intake.6. Clean the air cleaner's pre-filter (foam).	

SERVICE JOURNAL

Action	Date, mtr reading, stamp, sign
<p>50-Hour Service</p> <ol style="list-style-type: none">1. Perform the 25-hour service.2. Clean/replace the air cleaner's filter cartridge (paper filter) (shorter intervals for dusty operating conditions).3. Change the engine oil.4. Inspect muffler/spark arrester.5. Check/adjust the parking brake.	

SERVICE JOURNAL

Action	Date, mtr reading, stamp, sign
<p>100-Hour Service</p> <ol style="list-style-type: none">1. Perform the 25-hour service.2. Perform the 50-hour service.3. Change the engine oil filter.4. Clean/replace the spark plug.5. Clean the cooling fins on the engine and transmission.6. Check V-belts.7. Check tighten caster wheel axle bolts (every 200 hours).8. Change the air filter's paper cartridge.	

SERVICE JOURNAL

Action	Date, mtr reading, stamp, sign
<p>300-Hour Service</p> <ol style="list-style-type: none">1. Inspect the machine. Come to agreement with the customer as to which additional work is to be carried out.2. Perform the 25-hour service.3. Perform the 50-hour service.4. Perform the 100-hour service.5. Check/adjust the mower deck.6. Clean the combustion chamber and grind the valve seats.7. Check the engine valve clearance.8. Replace the air cleaner's pre-filter (foam).	

SERVICE JOURNAL

Action	Date, mtr reading, stamp, sign
<p>At Least Once Each Year</p> <ol style="list-style-type: none">1. Clean the engine's cooling air intake (25 hours).2. Replace the air cleaner's pre-filter (Oil-foam) (300 hours).3. Replace the air filter's paper cartridge.4. Change the engine oil (50 hours).5. Replace the engine oil filter (100 hours).7. Check/adjust the cutting height.8. Check/adjust the parking brake (50 hours).9. Clean/Change the spark plug (100 hours).11. Clean the cooling fins (100 hours).12. Check the engine valve clearance.13. Perform the 300-hour service at an authorized service workshop.	

