

PRO-FORM[®] XP

680 Crosstrainer

Model No. 831.24646.1

Serial No. _____

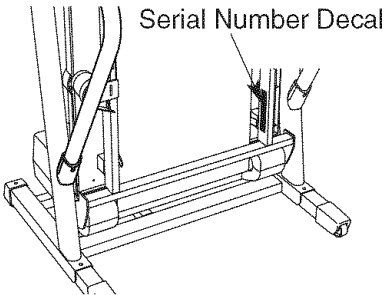

- Assembly
- Operation
- Maintenance
- Part List and Drawing

TREADMILL EXERCISER

User's Manual

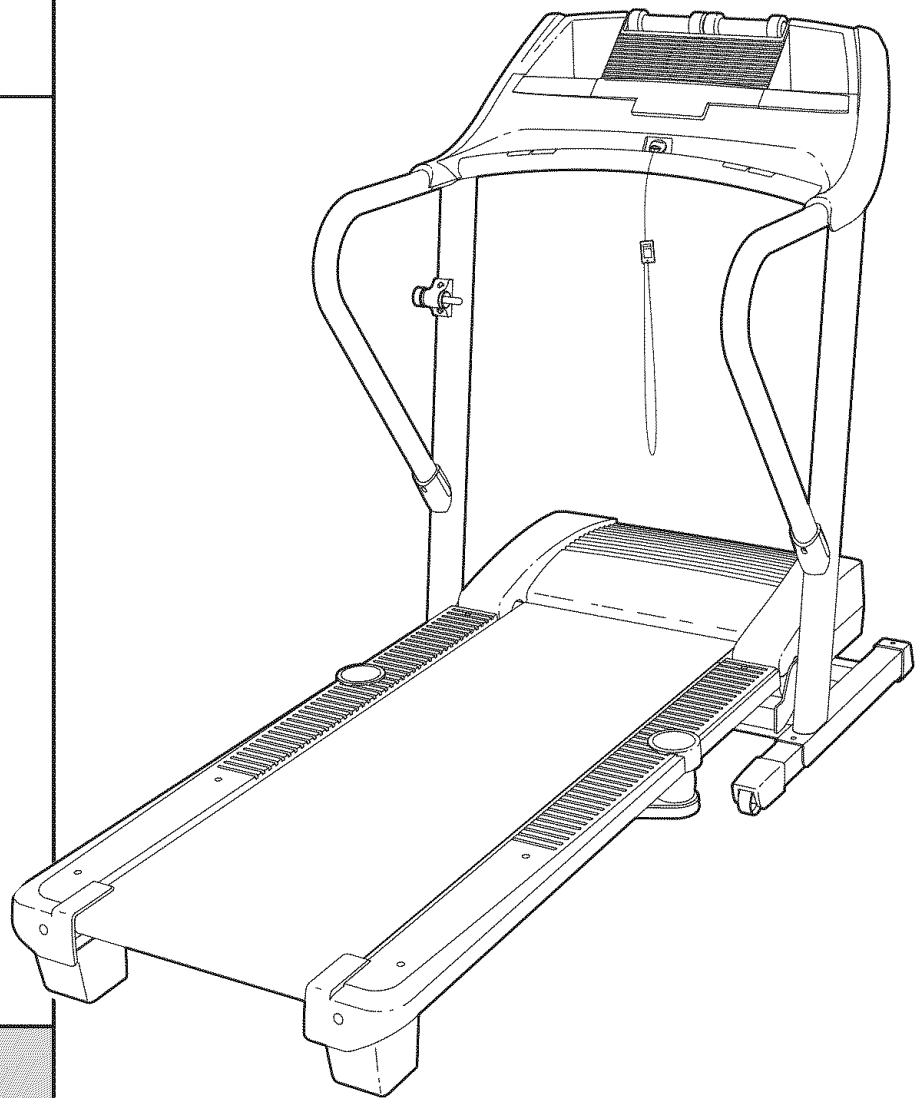

⚠ CAUTION

Read all precautions and instructions in this manual before using this equipment. Save this manual for future reference.

Sears, Roebuck and Co., Hoffman Estates, IL 60179

PRO-FORM[®] XP

680 Crosstrainer

TABLE OF CONTENTS

IMPORTANT PRECAUTIONS	3
BEFORE YOU BEGIN	5
ASSEMBLY	6
OPERATION AND ADJUSTMENT	9
HOW TO FOLD AND MOVE THE TREADMILL	18
TROUBLESHOOTING	19
CONDITIONING GUIDELINES	21
PART LIST	22
EXPLODED DRAWING	24
ORDERING REPLACEMENT PARTS	Back Cover
WARRANTY	Back Cover

IMPORTANT PRECAUTIONS

▲ WARNING: To reduce the risk of burns, fire, electric shock, or injury to persons, read the following important precautions and information before operating the treadmill.

1. It is the responsibility of the owner to ensure that all users of this treadmill are adequately informed of all warnings and precautions.
2. Use the treadmill only as described.
3. Place the treadmill on a level surface, with at least eight feet of clearance behind it and two feet on each side. Do not place the treadmill on any surface that blocks air openings. To protect the floor or carpet from damage, place a mat under the treadmill.
4. Keep the treadmill indoors, away from moisture and dust. Do not put the treadmill in a garage or covered patio, or near water.
5. Do not operate the treadmill where aerosol products are used or where oxygen is being administered.
6. Keep children under the age of 12 and pets away from the treadmill at all times.
7. The treadmill should be used only by persons weighing 300 pounds or less.
8. Never allow more than one person on the treadmill at a time.
9. Wear appropriate exercise clothes when using the treadmill. Do not wear loose clothes that could become caught in the treadmill. Athletic support clothes are recommended for both men and women. *Always wear athletic shoes. Never use the treadmill with bare feet, wearing only stockings, or in sandals.*
10. When connecting the power cord (see page 9), plug the power cord into a surge suppressor (not included) and plug the surge suppressor into a grounded circuit capable of carrying 15 or more amps. No other appliance should be on the same circuit. Do not use an extension cord.
11. Use only a single-outlet surge suppressor that meets all of the specifications described on page 9. To purchase a surge suppressor, see your local Sears store or call 1-800-366-7278 and order part number 146148, or see your local electronics store.
12. Failure to use a properly functioning surge suppressor could result in damage to the control system of the treadmill. If the control system is damaged, the walking belt may change speed, accelerate, or stop unexpectedly, which may result in a fall and serious injury.
13. Keep the power cord and the surge suppressor away from heated surfaces.
14. Never move the walking belt while the power is turned off. Do not operate the treadmill if the power cord or plug is damaged, or if the treadmill is not working properly. (See TROUBLESHOOTING on page 19 if the treadmill is not working properly.)
15. Read, understand, and test the emergency stop procedure before using the treadmill (see HOW TO TURN ON THE POWER on page 11).
16. Never start the treadmill while you are standing on the walking belt. Always hold the handrails while using the treadmill.
17. The treadmill is capable of high speeds. Adjust the speed in small increments to avoid sudden jumps in speed.
18. The pulse sensor is not a medical device. Various factors, including the user's movement, may affect the accuracy of heart rate readings. The pulse sensor is intended only as an exercise aid in determining heart rate trends in general.
19. Use the included dumbbells only as described in this manual. Properly store the dumbbells in the dumbbell holders on the console when you are not using them. If the dumbbells are improperly stored, they may fall off the console, causing the user to trip.

- 20. Never leave the treadmill unattended while it is running. Always remove the key, unplug the power cord, and switch the reset/off circuit breaker to the off position when the treadmill is not in use. (See the drawing on page 5 for the location of the circuit breaker.)
- 21. Do not attempt to raise, lower, or move the treadmill until it is properly assembled. (See ASSEMBLY on page 6, and HOW TO FOLD AND MOVE THE TREADMILL on page 18.) You must be able to safely lift 45 pounds (20 kg) to raise, lower, or move the treadmill.
- 22. When folding or moving the treadmill, make sure that the storage latch is fully closed.
- 23. Never insert any object into any opening on the treadmill.

- 24. Inspect and properly tighten all parts of the treadmill regularly.
- 25. **DANGER:** Always unplug the power cord immediately after use, before cleaning the treadmill, and before performing the maintenance and adjustment procedures described in this manual. Never remove the motor hood unless instructed to do so by an authorized service representative. Servicing other than the procedures in this manual should be performed by an authorized service representative only.
- 26. This treadmill is intended for in-home use only. Do not use this treadmill in a commercial, rental, or institutional setting.

▲ WARNING: Before beginning this or any exercise program, consult your physician. This is especially important for persons over the age of 35 or persons with pre-existing health problems. Read all instructions before using. Sears assumes no responsibility for personal injury or property damage sustained by or through the use of this product.

SAVE THESE INSTRUCTIONS

The decals shown at the right have been placed on your treadmill. If a decal is missing, or if it is not legible, call toll-free 1-888-533-1333 and order a free replacement decal. Apply the decal in the location shown. Note: The decals are not shown at actual size.

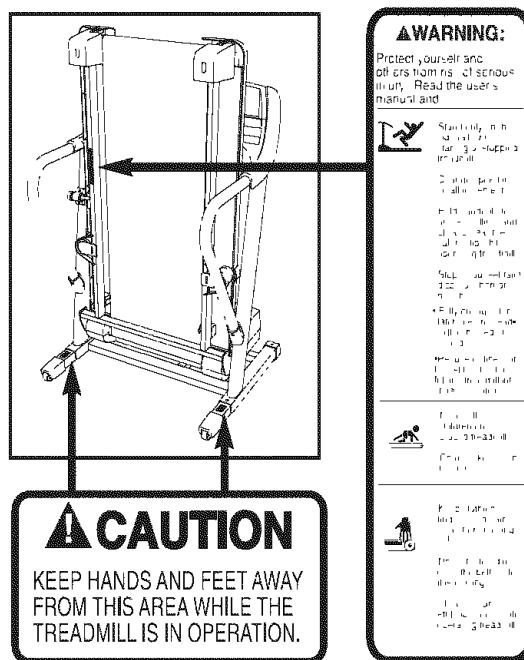

BEFORE YOU BEGIN

Thank you for selecting the revolutionary PROFORM® XP 680 CROSSTRAINER treadmill. The XP 680 CROSSTRAINER treadmill offers an impressive array of features designed to make your workouts at home more enjoyable and effective. And when you're not exercising, the unique XP 680 CROSSTRAINER treadmill can be folded up, requiring less than half the floor space of other treadmills.

For your benefit, read this manual carefully before using the treadmill. If you have questions after read-

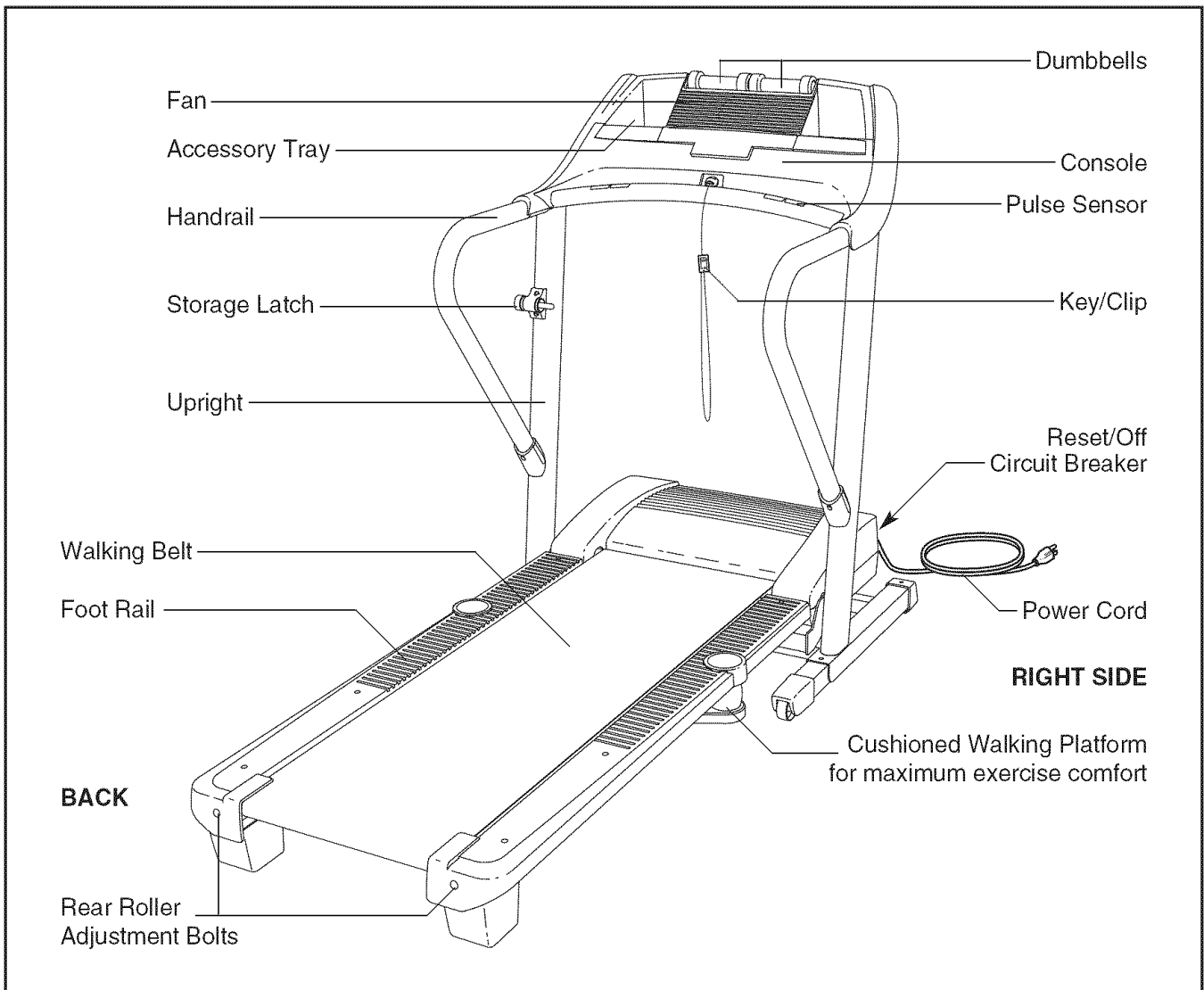

ing this manual, call 1-800-4-MY-HOME® (1-800-469-4663). To help us assist you, please note the product model number and serial number before calling. The model number of the treadmill is 831.24646.1. The serial number can be found on a decal attached to the treadmill (see the front cover of this manual for the location).

Before reading further, please review the drawing below and familiarize yourself with the labeled parts.

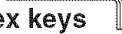

ASSEMBLY

Make sure that the power cord is unplugged. Assembly requires two persons. Set the treadmill in a cleared area and remove all packing materials. Do not dispose of the packing materials until assembly is completed. Note: The underside of the treadmill walking belt is coated with high-performance lubricant. During shipping, a small amount of lubricant may be transferred to the top of the walking belt or the shipping carton. This is a normal condition and does not affect treadmill performance. If there is lubricant on top of the walking belt, simply wipe off the lubricant with a soft cloth and a mild, non-abrasive cleaner.

Assembly requires the included hex keys  and your own phillips screwdriver .

Use the drawings below to identify the assembly hardware. The number in parentheses below each drawing is the key number of the part, from the PART LIST on pages 22 and 23. The number after the parentheses shows the quantity needed for assembly. Note: If a part is not in the parts bag, check to see if it is preattached to one of the parts to be assembled. **If a part is missing, call toll-free 1-888-533-1333. To avoid damaging plastic parts, do not use power tools for assembly.**

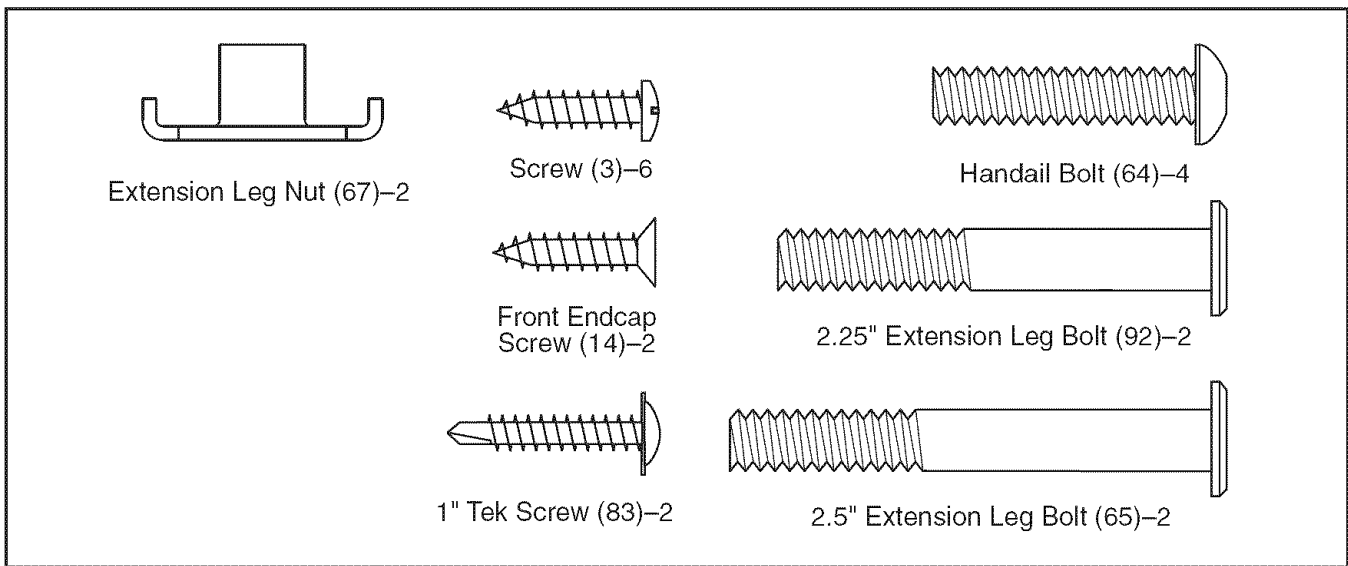

1. Make sure that the power cord is unplugged.

With the help of a second person, carefully tip the treadmill onto its left side as shown. Partially fold the Frame (58) so the treadmill is more stable. **Do not fully fold the Frame until the treadmill is completely assembled.**

Insert an Extension Leg (89) into the base of the Uprights (84). Hold an Extension Leg Nut (67) in the bottom of the Extension Leg, and thread a 2.25" Extension Leg Bolt (92) into the top of the Extension Leg. Next, thread a 2.5" Extension Leg Bolt (65) into the bottom of the Extension Leg. **Firmly tighten the Extension Leg Bolts.**

Slide a Front Endcap (44) onto the base of the Uprights (84). Partially tighten a Front Endcap Screw (14) into the Front Endcap and the base.

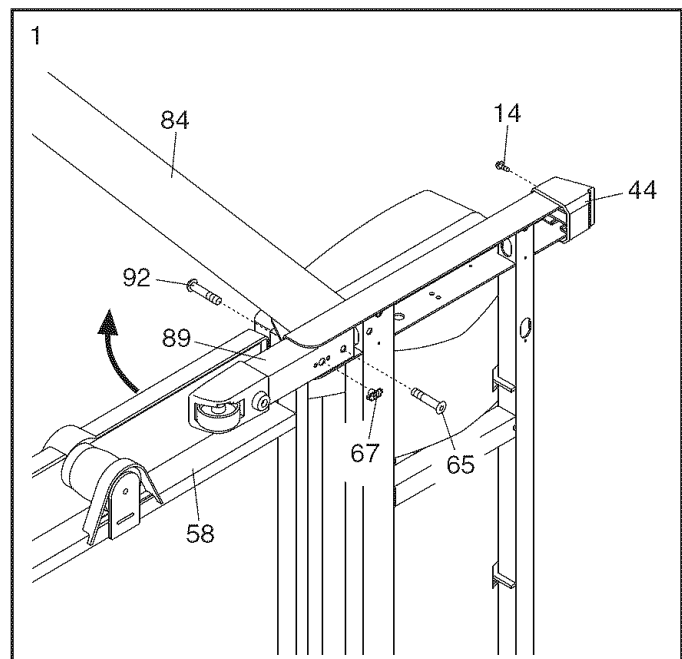

2. Insert the tab on one of the Handrail Brackets (42) into the indicated slot in the right Upright (84). Attach the Handrail Bracket with a Screw (3).

Slide a Handrail Cap (8) onto the lower end of a Handrail (20). Make sure that the Handrail Cap is oriented as shown.

Insert the top of the Handrail (20) into the tube at the top of the right Upright (84), and slide the Handrail Cap (8) over the Handrail Bracket (42). Attach the top of the Handrail to the right Upright with two Handrail Bolts (64); **start both Handrail Bolts but do not tighten them yet.** Then, attach the Handrail to the Handrail Bracket with a Screw (3). Tighten the two Handrail Bolts.

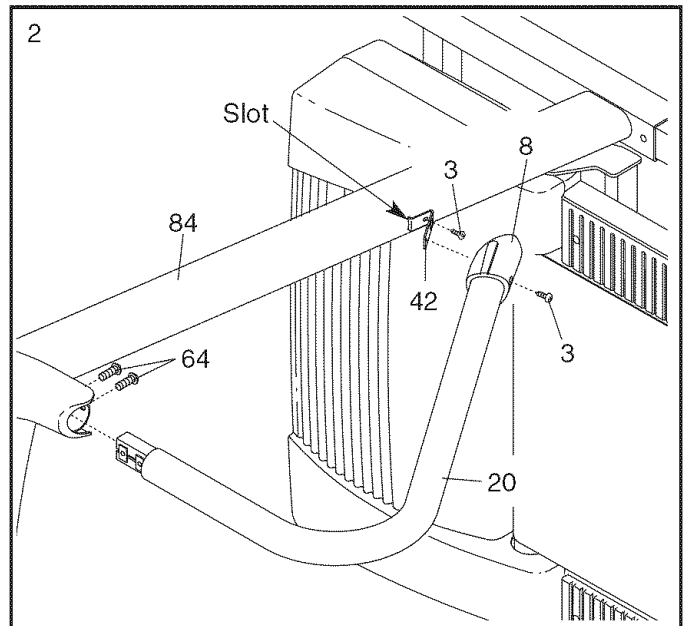

3. With the help of a second person, carefully tip the treadmill onto its right side. **Do not fully fold the treadmill until it is completely assembled.**

Insert the other Extension Leg (89) into the base of the Uprights (84). Hold an Extension Leg Nut (67) in the bottom of the Extension Leg, and thread a 2.25" Extension Leg Bolt (92) into the top of the Extension Leg. Next, thread a 2.5" Extension Leg Bolt (65) into the bottom of the Extension Leg. **Firmly tighten the Extension Leg Bolts.**

Slide the other Front Endcap (44) onto the base of the Uprights (84). Partially tighten a Front Endcap Screw (14) into the Front Endcap and the base.

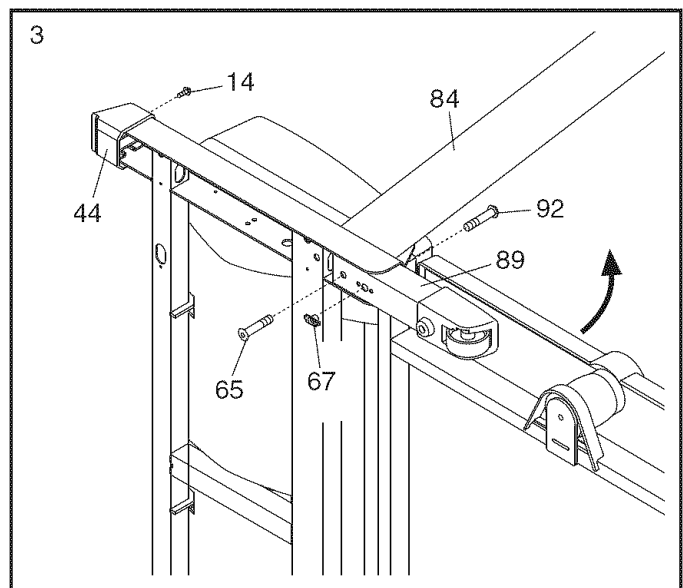

4. Attach two Base Pads (82) to the base of the Uprights (84) with two 1" Tek Screws (83).

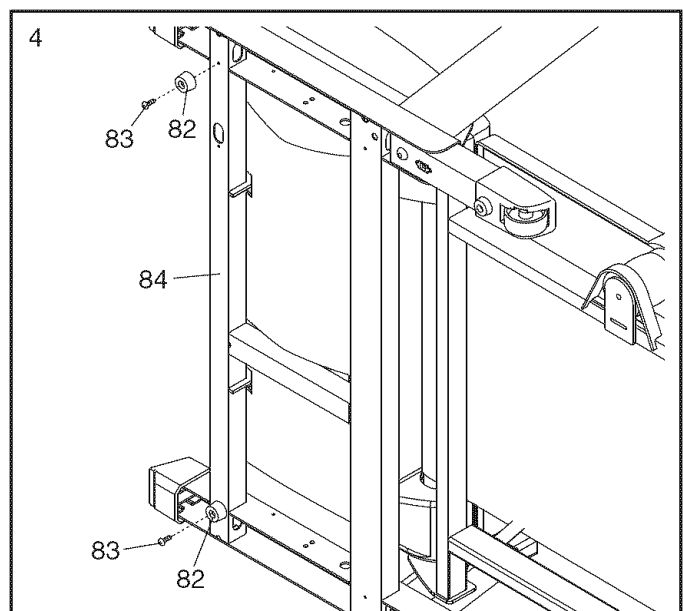

5. Insert the tab on the other Handrail Bracket (42) into the indicated slot in the left Upright (84). Attach the Handrail Bracket with a Screw (3).

Slide a Handrail Cap (8) onto the lower end of a Handrail (20). Make sure that the Handrail Cap is oriented as shown.

Insert the top of the Handrail (20) into the left Upright (84), and slide the Handrail Cap (8) over the Handrail Bracket (42). Attach the top of the Handrail to the left Upright with two Handrail Bolts (64); **start both Handrail Bolts but do not tighten them yet.** Then, attach the Handrail to the Handrail Bracket with a Screw (3). Tighten the two Handrail Bolts. **With the help of a second person, carefully raise the Uprights (84) to a vertical position.**

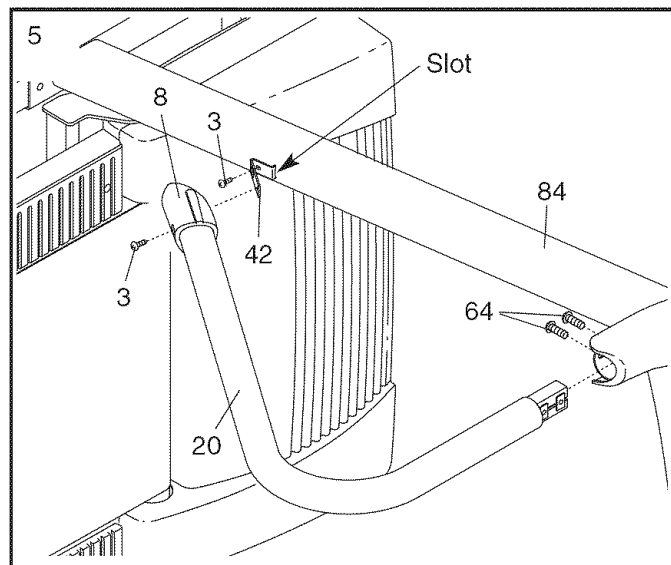

6. Attach the Latch Housing (73) to the left Upright (84) with two Screws (3); **start both Screws and then tighten them. Note: Make sure that the large hole in the Latch Housing is on the indicated side.**

Remove the knob from the pin. Make sure that the collar and the spring are on the pin. (Note: If there are two collars, place one on each side of the spring.) Next, insert the pin into the Latch Housing (73). Then, tighten the knob onto the pin.

See steps 1 and 3. Fully tighten the two Front Endcap Screws (14).

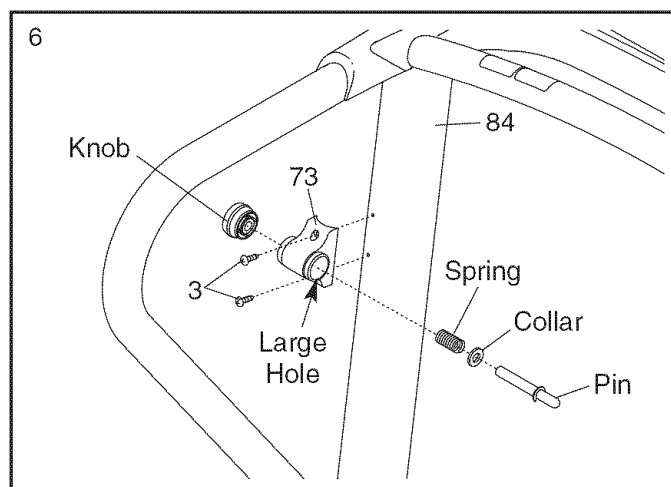

7. **Make sure that all parts are properly tightened before you use the treadmill.** If there are sheets of clear plastic on the treadmill decals, remove the plastic. To protect the floor or carpet, place a mat under the treadmill. Note: Extra hardware may be included. Keep the included hex key in a secure place; the large hex key is used to adjust the walking belt (see page 20).

If you purchase the optional chest pulse sensor (see page 17), follow the steps below to install the receiver included with the chest pulse sensor.

1. **Make sure that the power cord is unplugged.** Remove the indicated Screw (3) and the Access Door (76) from the back of the Console Base (85).
2. Connect the wire on the receiver (A) to the indicated wire extending from the Console Base (85). **Hold the receiver so the small cylinder is oriented as shown and is facing the Console Back.** Attach the receiver to the plastic posts on the Access Door (76) with the two included small screws.
3. **Make sure that no wires are pinched.** Reattach the Access Door (76) with the Screw (3). Discard the other wires included with the receiver.

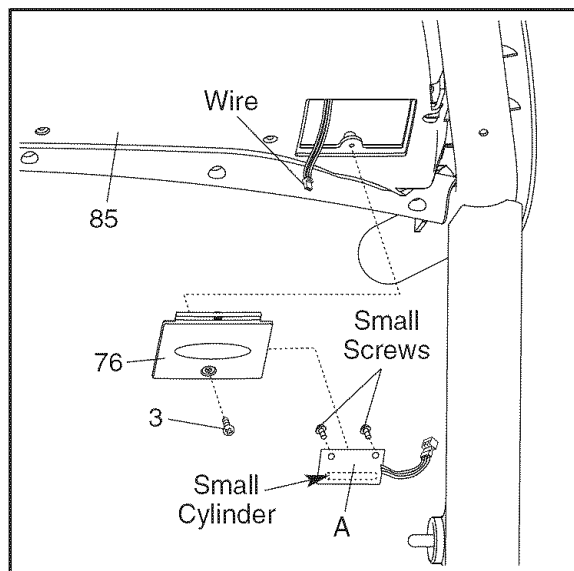

OPERATION AND ADJUSTMENT

THE PRE-LUBRICATED WALKING BELT

Your treadmill features a walking belt coated with high-performance lubricant. **IMPORTANT: Never apply silicone spray or other substances to the walking belt or the walking platform. Such substances will deteriorate the walking belt and cause excessive wear.**

HOW TO PLUG IN THE POWER CORD

⚠ DANGER: Improper connection of the equipment-grounding conductor can result in an increased risk of electric shock. Check with a qualified electrician or serviceman if you are in doubt as to whether the product is properly grounded. Do not modify the plug provided with the product—if it will not fit the outlet, have a proper outlet installed by a qualified electrician.

Your treadmill, like any other type of sophisticated electronic equipment, can be seriously damaged by sudden voltage changes in your home's power. Voltage surges, spikes, and noise interference can result from weather conditions or from other appliances being turned on or off. **To decrease the possibility of your treadmill being damaged, always use a surge suppressor with your treadmill (see drawing 1 at the right).** To purchase a surge suppressor, see your local Sears store or call 1-800-366-7278 and order part number 146148, or see your local electronics store.

Use only a single-outlet surge suppressor that is UL 1449 listed as a transient voltage surge suppressor (TVSS). The surge suppressor must have a UL suppressed voltage rating of 400 volts or less and a minimum surge dissipation of 450 joules. The surge suppressor must be electrically rated for 120 volts AC and 15 amps. There must be a monitoring light on the surge suppressor to indicate whether it is functioning properly. Failure to use a properly functioning surge suppressor could result in damage to the control system of the treadmill. If the control system is damaged, the walking belt may change speed, accelerate, or stop unexpectedly, which may result in a fall and serious injury.

This product must be grounded. If it should malfunction or break down, grounding provides a path of least resistance for electric current to reduce the risk of electric shock. This product is equipped with a cord having

an equipment-grounding conductor and a grounding plug. **Plug the power cord into a surge suppressor, and plug the surge suppressor into an appropriate outlet that is properly installed and grounded in accordance with all local codes and ordinances. Important: The treadmill is not compatible with GFCI-equipped outlets.**

This product is for use on a nominal 120-volt circuit, and has a grounding plug that looks like the plug illustrated in drawing 1 below. A temporary adapter that looks like the adapter illustrated in drawing 2 may be used to connect the surge suppressor to a 2-pole receptacle as shown in drawing 2 if a properly grounded outlet is not available.

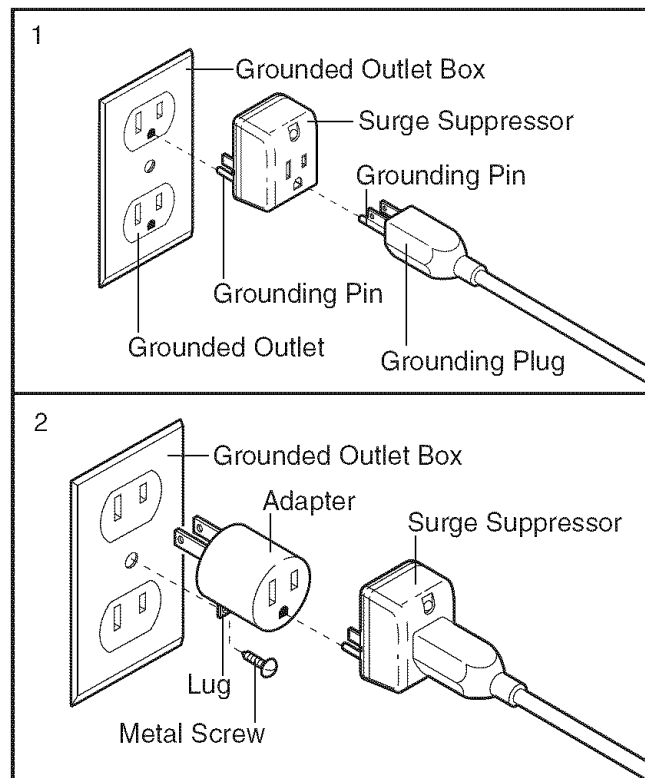

The temporary adapter should be used only until a properly grounded outlet (drawing 1) can be installed by a qualified electrician.

The green-colored rigid ear, lug, or the like extending from the adapter must be connected to a permanent ground such as a properly grounded outlet box cover. Whenever the adapter is used it must be held in place by a metal screw. **Some 2-pole receptacle outlet box covers are not grounded. Contact a qualified electrician to determine if the outlet box cover is grounded before using an adapter.**

CONSOLE DIAGRAM

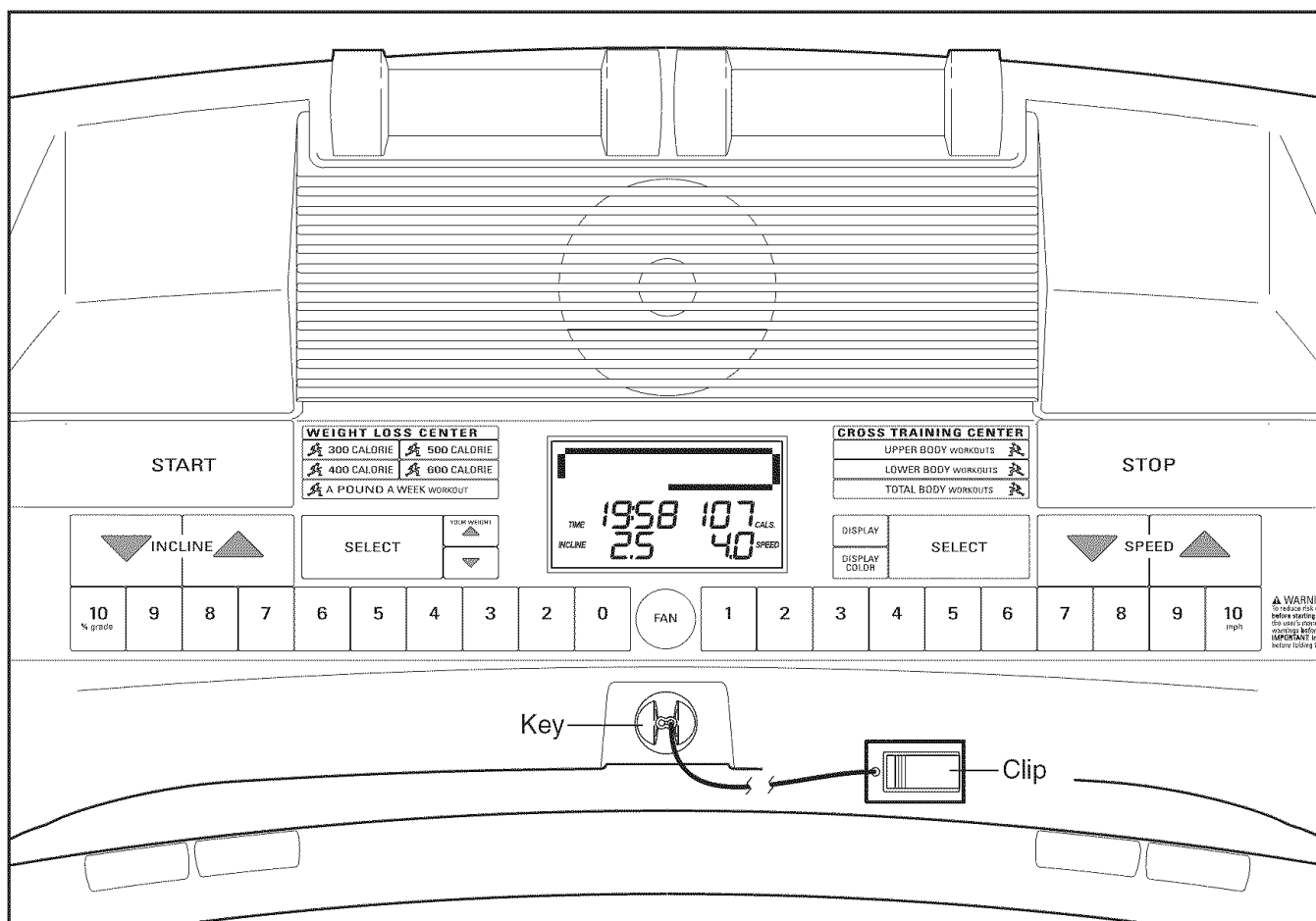

FEATURES OF THE CONSOLE

The treadmill console offers a selection of features designed to make your workouts more effective and enjoyable.

When you select the manual mode of the console, you can change the speed and incline of the treadmill with the touch of a button. As you exercise, the console will display continuous exercise feedback. You can even measure your heart rate using the handgrip pulse sensor or the optional chest pulse sensor (see page 17 for information about the optional chest pulse sensor).

The console also features eight calorie programs that automatically control the speed and incline of the treadmill to help you burn excess calories during your workouts. You can even lose unwanted pounds with the effective new pound-a-week weight-loss program.

In addition, the console offers six cross training programs designed to help you to burn calories and enhance your cardiovascular system while toning and

strengthening your muscles. The cross training programs control the speed and incline of the treadmill and prompt you to perform a variety of strength exercises during your workouts. Two upper body programs, two lower body programs, and two total body programs are offered. Note: The strength exercises require the use of dumbbells and an inflatable exercise ball (not included). **To purchase dumbbells or an exercise ball, call toll-free 1-888-533-1333.**

To use the manual mode of the console, follow the steps beginning on page 11. **To use a calorie program**, see page 13. **To use the pound-a-week program**, see page 14. **To use a cross training program**, see page 15.

Note: If there is a sheet of clear plastic on the face of the console, remove the plastic. To prevent damage to the walking platform, wear clean athletic shoes while using the treadmill. The first time the treadmill is used, observe the alignment of the walking belt, and center the walking belt if necessary (see page 20).

HOW TO TURN ON THE POWER

Plug in the power cord (see page 9).

Locate the reset/off circuit breaker near the power cord. Make sure that the circuit breaker is in the reset position.

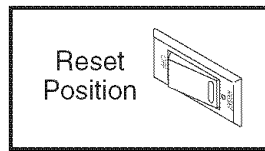

Next, step onto the foot rails of the treadmill. Find the clip attached to the key (see the drawing on page 10) and slide the clip securely onto the waistband of your clothes. Then, insert the key into the console. After a moment, the display will light. **Important: In an emergency situation, the key can be pulled from the console, causing the walking belt to slow to a stop. Test the clip by carefully taking a few steps backward; if the key is not pulled from the console, adjust the position of the clip.**

HOW TO USE THE MANUAL MODE

1 Insert the key into the console.

See HOW TO TURN ON THE POWER above.

2 Enter your weight if desired.

If you enter your weight into the console, the console will display a more accurate estimate of the number of calories that you burn. To enter your weight, press the weight increase and decrease buttons repeatedly. Note: Once you have entered your weight, it will be saved in memory.

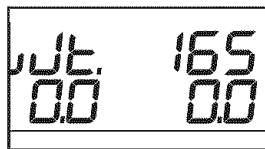

3 Select the manual mode.

When the key is inserted, the manual mode will be selected. If you have selected a program, reselect the manual mode by pressing either of the Select buttons repeatedly until a track appears in the upper half of the display.

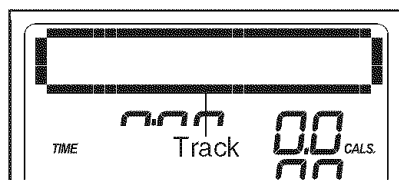

4 Start the walking belt.

To start the walking belt, press the Start button, the Speed increase button, or one of the speed buttons numbered 1 to 10.

If you press the Start button or the Speed increase button, the walking belt will begin to move at 1 mph. As you exercise, change the speed of the walking belt as desired by pressing the Speed increase and decrease buttons. Each time a button is pressed, the speed setting will change by 0.1 mph; if a button is held down, the speed setting will change in increments of 0.5 mph. Note:

After the buttons are pressed, it may take a moment for the walking belt to reach the selected speed setting.

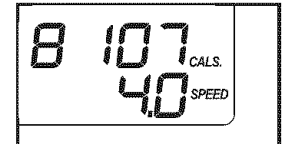

If one of the numbered speed buttons is pressed, the walking belt will gradually change speed until it reaches the selected speed setting.

To stop the walking belt, press the Stop button. The time will begin to flash in the display. To restart the walking belt, press the Start button, the Speed increase button, or one of the numbered speed buttons.

5 Change the incline of the treadmill as desired.

To change the incline of the treadmill, press the Incline increase and decrease buttons or one of the incline buttons numbered 0 to 10. Each time the Incline increase or decrease button is pressed, the incline will change by 0.5%. If one of the numbered incline buttons is pressed, the treadmill will adjust to the selected incline setting. Note: After the buttons are pressed, it may take a moment for the treadmill to reach the selected incline setting.

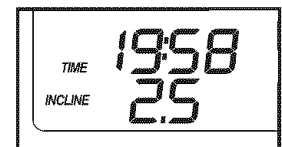

6 Follow your progress with the display.

Note: The display features six background colors. To select a color, press the Display Color button repeatedly. To adjust the contrast of the display, see THE INFORMATION MODE on page 17.

When the manual mode is selected, the upper part of the display will show a track that represents 1/4 mile. As you walk or run, indicators will appear in succession around the track until the entire track appears. The track will then disappear and the indicators will again begin to appear in succession.

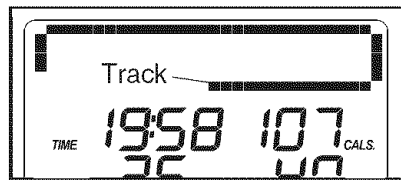

In the manual mode, the upper part of the display can also show the elapsed

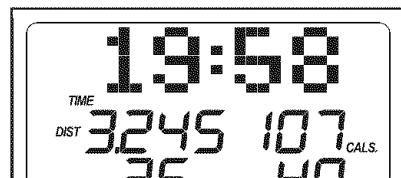

time, the distance that you have walked or run, the speed of the walking belt, the approximate number of calories you have burned while walking or running, your pace in minutes per mile, or the incline level of the treadmill. If desired, press the Display button repeatedly until the upper part of the display shows the information you are most interested in viewing. Note: While information is shown in the upper part of the display, the same information will not be shown in the lower parts of the display.

The left side of the display can show the elapsed time, the distance that you have walked or run, the approximate number of grams of carbs that you have burned, and the incline level of the treadmill. Note: When a program is selected, the display will show the time remaining in the program instead of the elapsed time.

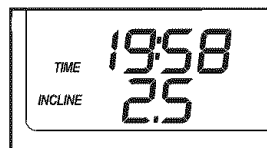

The right side of the display can show the approximate number of calories you have burned, the speed of the walking belt, and your pace in minutes per mile. The right side of the display will also show your heart rate when you use the handgrip pulse sensor or the optional chest pulse sensor.

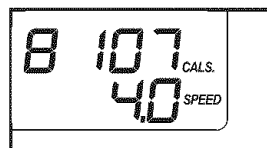

Note: The console can display speed and distance in either miles or kilometers. To find out which unit of measurement is selected or to change the unit of measurement, see THE INFORMATION MODE on page 17. **For simplicity, all instructions in this section refer to miles.**

To reset the display, press the Stop button, remove the key, and then reinsert the key.

7 Measure your heart rate if desired.

Note: If you use the handgrip pulse sensor and the optional chest pulse sensor at the same time, the console will not display your heart rate accurately.

Before using the handgrip pulse sensor, remove the sheets of clear plastic from the metal contacts. In addition, make sure that your hands are clean.

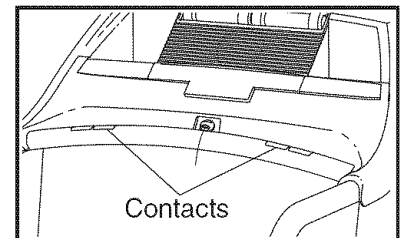

To measure your heart rate, **stand on the foot rails** and hold the metal contacts on the handrail—**avoid moving your hands**. When your pulse is detected, a heart-shaped indicator will flash in the right side of the display each time your heart beats, one or two dashes will appear, and then your heart rate will be shown. **For the most accurate heart rate reading, continue to hold the contacts for about 15 seconds.**

8 Turn on the fan if desired.

To turn on the fan, press the Fan button. To turn on the fan at high speed, press the button a second time. To turn off the fan, press the button a third time. Note: If the fan is on when the walking belt stops, the fan will automatically turn off after a few minutes.

9 When you are finished exercising, remove the key.

Step onto the foot rails, press the Stop button, and **adjust the incline of the treadmill to the lowest setting. The incline must be at the lowest setting when you fold the treadmill to the storage position or you will damage the treadmill.** Next, remove the key from the console and put it in a secure place. **Note: If the display remains lit after the key is removed, the console is in the “demo” mode. See page 17 and turn off the demo mode.**

When you are finished using the treadmill, switch the reset/off circuit breaker to the “off” position and unplug the power cord.

HOW TO USE A CALORIE PROGRAM

1 Insert the key into the console.

See HOW TO TURN ON THE POWER on page 11.

2 Enter your weight.

See step 2 on page 11. **Note: Always enter your weight before using a calorie program; the speed and incline settings of the program will depend on the weight setting that you enter.**

3 Select a calorie program.

To select one of the eight calorie programs, press the left Select button repeatedly.

When a calorie program is selected, the display will show the calorie goal (the approximate number of calories to be burned during the program) and the number of minutes that the program will last. In addition, the maximum incline setting of the program and the maximum speed setting of the program will flash in the display. A few seconds after a calorie program is selected, a profile of the speed settings of the program will scroll across the display.

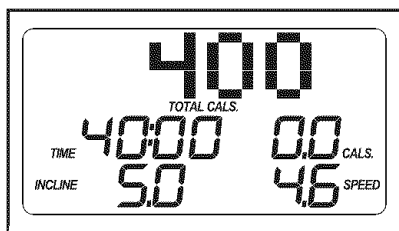

4 Press the Start button to start the program.

A moment after the button is pressed, the treadmill will automatically adjust to the first speed and incline settings of the program. Hold the handrails and begin walking.

Each program is divided into 30, 40, 45, 50, 55, or 60 one-minute segments. One speed setting and one incline setting are programmed for each segment. **Note:** The same speed setting and/or incline setting may be programmed for two or more consecutive segments.

The speed setting for the first segment will be shown in the flashing

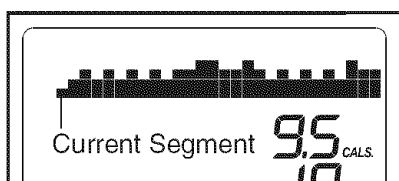

Current Segment column in the display. (The incline settings are not shown in the display.) The speed settings for the next several segments will be shown in the columns to the right.

When only three seconds remain in the first segment of the program, both the Current Segment column and the column to the right will flash and a series of tones will sound. If the speed and/or incline of the treadmill is about to change, the speed setting and/or the incline setting will flash in the display to alert you.

When the first segment is completed, *all speed settings will move one column to the left.* The speed setting for the second segment will then be shown in the flashing Current Segment column and the treadmill will automatically adjust to the speed and incline settings for the second segment. **Note:** If all the indicators in the Current Segment column are lit, the speed settings may move downward so that only the highest indicators appear in the display.

If the speed or incline setting for the current segment is too high or too low, you can manually override the setting by pressing the Speed and Incline buttons. Every few times a Speed button is pressed, an additional indicator will appear or disappear in the Current Segment column.

Important: When the current segment of the program ends, the treadmill will automatically adjust to the speed and incline settings for the next segment.

To stop the program at any time, press the Stop button. The time will begin to flash in the display. To restart the program, press the Start button or the Speed increase button. The walking belt will begin to move at 1 mph. When the next segment of the program begins, the treadmill will automatically adjust to the speed and incline settings for that segment.

The program will continue in this way until the last segment of the program ends. The walking belt will then slow to a stop. **Important: The calorie goal is an estimate of the number of calories that you will burn during the program. The actual number of calories that you burn will depend on your weight. In addition, if you manually change the speed or incline of treadmill during the program, the number of calories you burn will be affected.**

5 Follow your progress with the display.

See step 6 on pages 11 and 12.

6 Measure your heart rate if desired.

See step 7 on page 12.

7 Turn on the fan if desired.

See step 8 on page 12.

8 When you are finished exercising, remove the key from the console.

See step 9 on page 12.

HOW TO USE THE POUND-A-WEEK PROGRAM

The exciting new pound-a-week program is a weight-loss program designed to help you lose 3600 calories, equal to one pound of excess fat, in five days. For variety, each of the daily 60-minute workouts offers different speed and incline settings from the previous day's workout.

On days 1, 3, and 5, you will burn approximately 800 calories each day, and on days 2 and 4, you will burn approximately 600 calories each day. **Important: The actual number of calories that you burn will depend on your weight. In addition, if you manually change the speed or incline of treadmill during the program, the number of calories you burn will be affected.**

1 Insert the key into the console.

See HOW TO TURN ON THE POWER on page 11.

2 Enter your weight.

See step 2 on page 11. **Note: Always enter your weight before using the pound-a-week program; the speed and incline settings of the program will depend on the weight setting that you enter.**

3 Select the pound-a-week program.

To select the pound-a-week program, press the left Select button. When the pound-a-week program is selected, the words "A Pound A Week" will appear in the display, followed by "Day 1," "Day 2," "Day 3," "Day 4," or "Day 5." In addition, the maximum incline setting of the program and the maximum speed setting of the program will flash in the display. A few seconds after the pound-a-week program is selected, a profile of the speed settings of the program will scroll across the display.

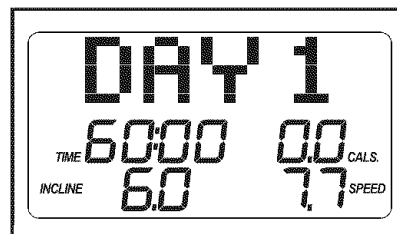

4 Press the Start button to start the program.

The pound-a-week program will function in the same way as a calorie program (see step 4 on page 13).

Note: Once you have started a pound-a-week daily workout, the console will automatically start you on the next day's workout the next time you select the pound-a-week program.

5 Follow your progress with the display.

See step 6 on pages 11 and 12.

6 Measure your heart rate if desired.

See step 7 on page 12.

7 Turn on the fan if desired.

See step 8 on page 12.

8 When you are finished exercising, remove the key from the console.

See step 9 on page 12.

HOW TO USE A CROSS TRAINING PROGRAM

1 Insert the key into the console.

See HOW TO TURN ON THE POWER on page 11.

2 Select a cross training program.

To select one of the six cross training programs, press the right Select button repeatedly.

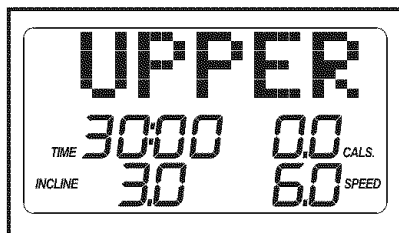

When a cross training program is selected, the display will show the word UPPER, LOWER, or TOTAL and the number of minutes that the program will last. In addition, the maximum incline setting of the program and the maximum speed setting of the program will flash in the display. A few seconds after a cross training program is selected, a profile of the speed settings of the program will scroll across the display.

3 Press the Start button to start the program.

A moment after the button is pressed, the treadmill will automatically adjust to the first speed and incline settings of the program. Hold the handrails and begin walking.

Each program is divided into 25, 30, or 45 one-minute segments. One speed setting and one incline setting are programmed for most segments. (Note: The same speed setting and/or incline setting may be programmed for two or more consecutive segments.) During other segments, the console will prompt you to perform strength exercises.

The speed setting for the first segment will be shown in the flashing Current Segment column of the display.

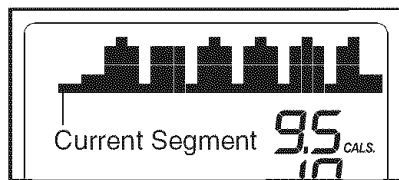

(The incline settings are not shown in the display.) The speed

settings for the next several segments will be shown in the columns to the right.

When only three seconds remain in the first segment of the program, both the Current Segment column and the column to the right will flash and a series of tones will sound. If the speed and/or incline of the treadmill is about to change, the speed setting and/or the incline setting will flash in the display to alert you.

When the first segment is completed, *all speed settings will move one column to the left.* The speed setting for the second segment will then be shown in the flashing Current Segment column and the treadmill will automatically adjust to the speed and incline settings for the second segment. Note: If all the indicators in the Current Segment column are lit, *the speed settings may move downward* so that only the highest indicators appear in the display.

If the speed or incline setting for the current segment is too high or too low, you can manually override the setting by pressing the Speed and Incline buttons. Every few times a Speed button is pressed, an additional indicator will appear or disappear in the Current Segment column; if any of the columns to the right of the Current Segment column have the same number of lit indicators as the Current Segment column, an additional indicator may appear or disappear in those columns as well. **Important: When the current segment of the program ends, the treadmill will automatically adjust to the speed and incline settings for the next segment.**

To stop the program at any time, press the Stop button. The time will begin to flash in the display. To restart the program, press the Start button or the Speed increase button. The walking belt will begin to move at 1 mph. When the next segment of the program begins, the treadmill will automatically adjust to the speed and incline settings for that segment.

4 Perform the first strength exercise when prompted.

When the first strength exercise segment begins (only one indicator will flash in the Current Segment column), the walking belt will slow to a stop and the name of the first strength exercise will appear in the display for a few seconds.

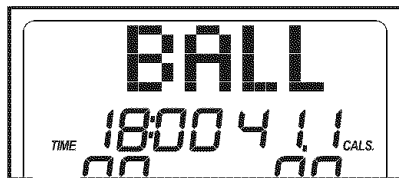

Next, the display will show the recommended number of repetitions for the first strength exercise.



Remove the clip from the waistband of your clothes, step off the treadmill, and prepare to begin the first strength exercise. Every few seconds, the console will sound a tone; when a tone sounds, perform one repetition of the exercise. Exercise with a slow, steady motion; do not perform more than one repetition each time a tone sounds. The display will count down the repetitions as you perform them.

Note: Refer to the accompanying exercise chart to see the correct form for each exercise. When performing lunges, alternate legs with each repetition. When performing dumbbell rows, perform half the

repetitions with your right arm and half the repetitions with your left arm. The strength exercises require the use of dumbbells and an inflatable exercise ball (not included). **To purchase dumbbells or an exercise ball, call toll-free 1-888-533-1333.**

5 Continue the cross training program.

When you have performed the recommended number of repetitions, the words PRESS START will appear in the display. To continue the cross training program, step onto the treadmill, **slide the clip back onto the waistband of your clothes**, and press the Start button. The treadmill will automatically adjust to the speed and incline settings for the next segment.

The program will continue in this way until the last segment ends. The walking belt will then slow to a stop.

6 Follow your progress with the display.

See step 6 on pages 11 and 12.

7 Measure your heart rate if desired.

See step 7 on page 12.

8 Turn on the fan if desired.

See step 8 on page 12.

9 When you are finished exercising, remove the key from the console.

See step 9 on page 12.

THE INFORMATION MODE

The console features an information mode that keeps track of treadmill usage information. The information mode also allows you to select miles or kilometers as the unit of measurement, to adjust the contrast of the display, and to turn on and turn off the demo mode.

To select the information mode, hold down the Stop button, insert the key into the console, and then release the Stop button. When the information mode is selected, the following information will appear in the display:

A number from 1 to 20 will appear in the upper part of the display. This number is the contrast setting of the display; 1 is the lowest setting and 20 is the highest setting. To change the contrast of the display, press the weight increase and decrease buttons.

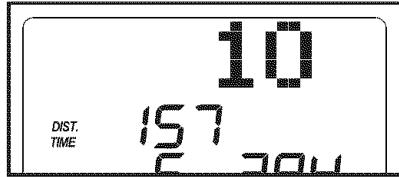

The center of the display will show the number of hours that the treadmill has been operated. The lower right corner of the display will show the total number of miles or kilometers that the walking belt has moved.

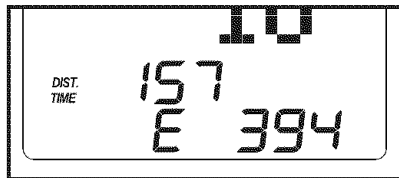

In addition, an "E" for English miles or an "M" for metric kilometers will appear in the lower left part of the display. To change the unit of measurement, press the Speed increase button.

IMPORTANT: If a "d" appears in the display, the console is in the "demo" mode. This mode is intended to be used only when the treadmill is displayed in a store. When the console is in the demo mode, the power cord can be plugged in, the key can be removed from the console, and the indicators in the display will automatically appear in a preset sequence; the buttons on the console will not operate. **If a "d" appears when the information mode is selected, press the Speed decrease button so that the "d" disappears.**

To exit the information mode, remove the key from the console.

THE OPTIONAL CHEST PULSE SENSOR

An optional chest pulse sensor offers hands-free operation as it continuously tracks your heart rate during your workouts. **To purchase the optional chest pulse sensor, call toll-free 1-888-533-1333.**

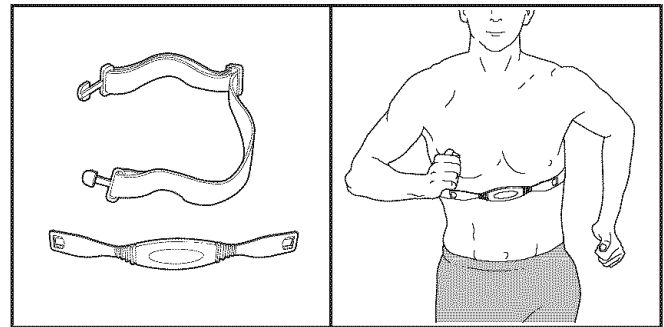

HOW TO FOLD AND MOVE THE TREADMILL

HOW TO FOLD THE TREADMILL FOR STORAGE

Before folding the treadmill, adjust the incline to the lowest position. If this is not done, the treadmill may be permanently damaged. Remove the key and unplug the power cord. **CAUTION: You must be able to safely lift 45 pounds (20 kg) to raise, lower, or move the treadmill.**

1. Hold the treadmill with your hands in the location shown by the arrow at the right. **CAUTION: To decrease the possibility of injury, bend your legs and keep your back straight. As you raise the frame, make sure to lift with your legs rather than your back.** Raise the frame about halfway to the vertical position.

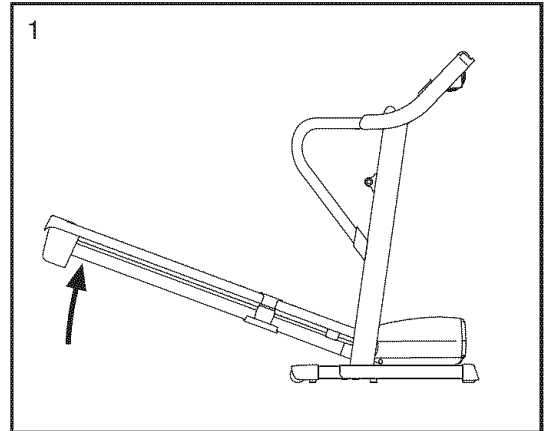

2. Move your right hand to the position shown, and hold the treadmill firmly. Using your left hand, pull the latch knob to the left and hold it. Raise the frame until the catch is past the latch pin. Then, slowly release the latch knob. **Make sure that the frame is securely held by the latch pin.**

To protect the floor or carpet from damage, place a mat under the treadmill. Keep the treadmill out of direct sunlight. Do not leave the treadmill in the storage position in temperatures above 85° Fahrenheit.

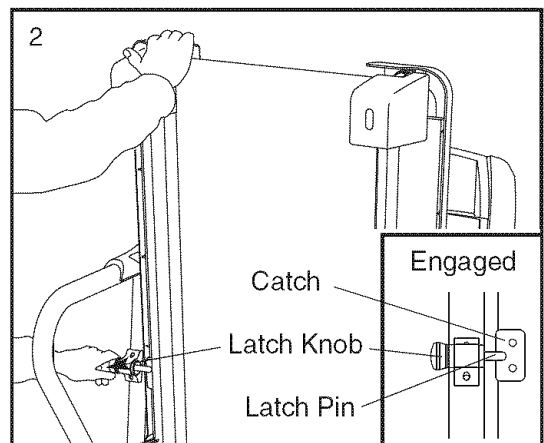

HOW TO MOVE THE TREADMILL

Before moving the treadmill, convert it to the storage position as described above. **Make sure that the frame is held securely by the latch pin.**

1. Hold the handrails and place one foot against one of the wheels.
2. Tilt the treadmill back until it rolls freely on the wheels. Carefully move the treadmill to the desired location. **Never move the treadmill without tipping it back. To reduce the risk of injury, use extreme caution while moving the treadmill. Do not attempt to move the treadmill over an uneven surface.**
3. Place one foot against a wheel, and carefully lower the treadmill until it is resting in the storage position.

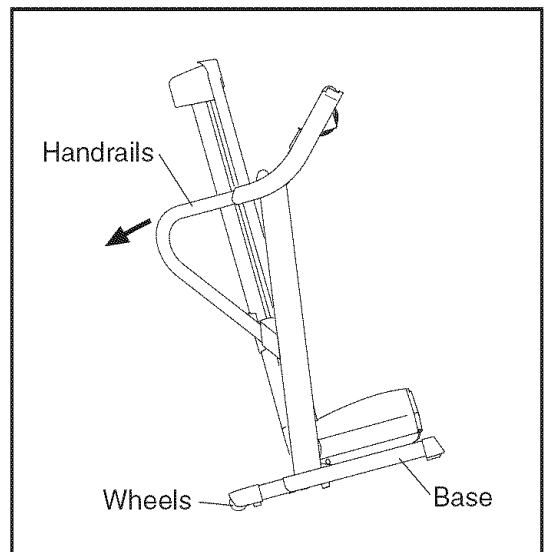

HOW TO LOWER THE TREADMILL FOR USE

1. See drawing 2 above. Hold the upper end of the treadmill with your right hand. Pull the latch knob to the left and hold it. Pivot the frame down until it is past the latch pin.
2. See drawing 1 above. Hold the frame firmly with both hands, and lower it to the floor. **CAUTION: To decrease the possibility of injury, bend your legs and keep your back straight.**

TROUBLESHOOTING

Most treadmill problems can be solved by following the simple steps below. Find the symptom that applies, and follow the steps listed. If further assistance is needed, call toll-free 1-800-4-MY-HOME® (1-800-469-4663).

PROBLEM: The power does not turn on

SOLUTION: a. Make sure that the power cord is plugged into a surge suppressor, and that the surge suppressor is plugged into a properly grounded outlet (see page 9). Use only a single-outlet surge suppressor that meets all of the specifications described on page 9. Important: The treadmill is not compatible with GFCI-equipped outlets.

b. After the power cord has been plugged in, make sure that the key is inserted into the console.

c. Check the reset/off circuit breaker located on the treadmill frame near the power cord. If the switch protrudes as shown, the circuit breaker has tripped. To reset the circuit breaker, wait for five minutes and then press the switch back in.

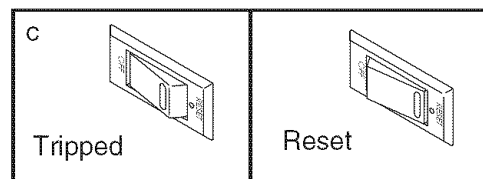

PROBLEM: The power turns off during use

SOLUTION: a. Check the reset/off circuit breaker (see the drawing above). If the circuit breaker has tripped, wait for five minutes and then press the switch back in.

b. Make sure that the power cord is plugged in. If the power cord is plugged in, unplug it, wait for five minutes, and then plug it back in.

c. Remove the key from the console. Reinsert the key into the console.

d. If the treadmill still will not run, please call toll-free 1-800-4-MY-HOME® (1-800-469-4663).

PROBLEM: The incline of the treadmill does not change correctly

SOLUTION: a. With the key in the console, press one of the Incline buttons. **While the incline is changing, remove the key.** After a few seconds, re-insert the key. The treadmill will automatically rise to the maximum incline level and then return to the minimum level. This will recalibrate the incline system.

PROBLEM: The displays of the console do not function properly

SOLUTION: a. Remove the key from the console and **UNPLUG THE POWER CORD.** Remove the three hood Screws (7). Carefully pivot the Hood (41) off.

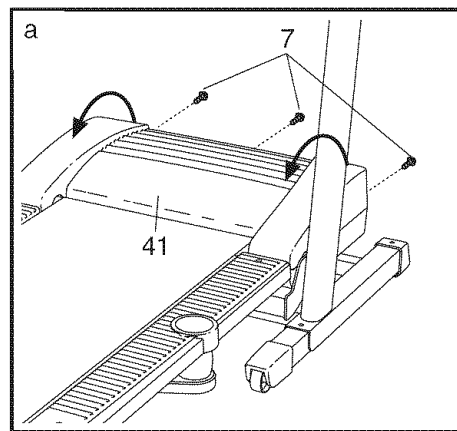

Locate the Reed Switch (63) and the Magnet (46) on the left side of the Pulley (47). Turn the Pulley until the Magnet is aligned with the Reed Switch. **Make sure that the gap between the Magnet and the Reed Switch is about 1/8"**. If necessary, loosen the Screw (7), move the Reed Switch slightly, and then retighten the Screw. Reattach the Hood, and run the treadmill for a few minutes to check for a correct speed reading.

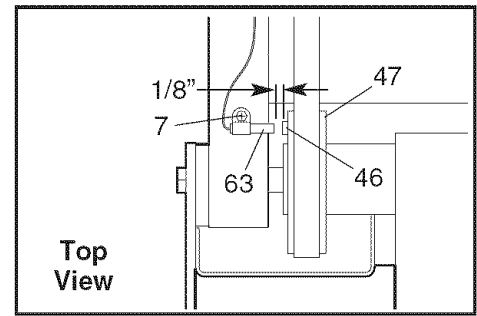

PROBLEM: The walking belt slows when walked on

SOLUTION: a. Use only a single-outlet surge suppressor that meets all of the specifications described on page 8.

b. If the walking belt is overtightened, treadmill performance may decrease and the walking belt may become damaged. Remove the key and **UNPLUG THE POWER CORD**. Using the hex key, turn both rear roller bolts counterclockwise, 1/4 of a turn. When the walking belt is properly tightened, you should be able to lift each edge of the walking belt 2 to 3 inches off the walking platform. Be careful to keep the walking belt centered. Then, plug in the power cord, insert the key, and run the treadmill for a few minutes. Repeat until the walking belt is properly tightened.

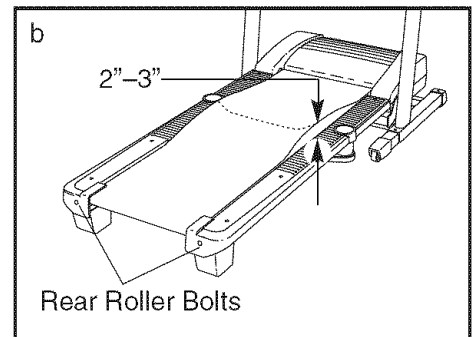

c. If the walking belt still slows when walked on, please call toll-free 1-800-4-MY-HOME® (1-800-469-4663).

PROBLEM: The walking belt is off-center or slips when walked on

SOLUTION: a. **If the walking belt is off-center**, first remove the key and **UNPLUG THE POWER CORD**. **If the walking belt has shifted to the left**, use the hex key to turn the left rear roller bolt clockwise 1/2 of a turn; **if the walking belt has shifted to the right**, turn the bolt counterclockwise 1/2 of a turn. Be careful not to overtighten the walking belt. Then, plug in the power cord, insert the key, and run the treadmill for a few minutes. Repeat until the walking belt is centered.

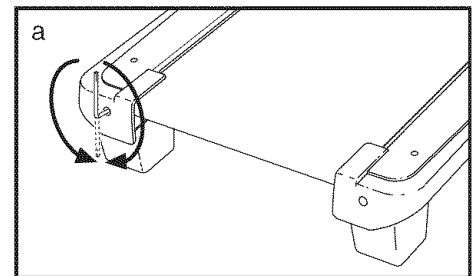

b. **If the walking belt slips when walked on**, first remove the key and **UNPLUG THE POWER CORD**. Using the hex key, turn both rear roller bolts clockwise, 1/4 of a turn. When the walking belt is correctly tightened, you should be able to lift each edge of the walking belt 2 to 3 inches off the walking platform. Be careful to keep the walking belt centered. Then, plug in the power cord, insert the key, and carefully walk on the treadmill for a few minutes. Repeat until the walking belt is properly tightened.

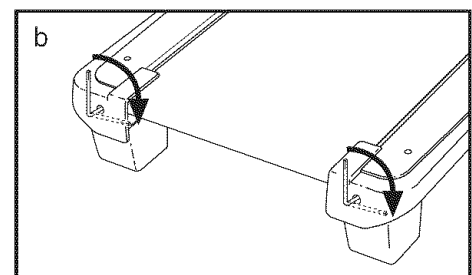

CONDITIONING GUIDELINES

⚠️ WARNING: Before beginning this or any exercise program, consult your physician. This is especially important for individuals over the age of 35 or individuals with pre-existing health problems.

The pulse sensor is not a medical device. Various factors, including your movement, may affect the accuracy of heart rate readings. The sensor is intended only as an exercise aid in determining heart rate trends in general.

The following guidelines will help you to plan your exercise program. For more detailed exercise information, obtain a reputable book or consult your physician.

EXERCISE INTENSITY

Whether your goal is to burn fat or to strengthen your cardiovascular system, the key to achieving the desired results is to exercise with the proper intensity. The proper intensity level can be found by using your heart rate as a guide. The chart below shows recommended heart rates for fat burning and aerobic exercise.

AEROBIC	165	155	145	140	130	125	115
MAX FAT BURN	145	138	130	125	118	110	103
FAT BURN	125	120	115	110	105	95	90
Age	20	30	40	50	60	70	80

To find the proper heart rate for you, first find your age near the bottom of the chart (ages are rounded off to the nearest ten years). Next, find the three numbers above your age. The three numbers define your “training zone.” The lower two numbers are recommended heart rates for fat burning; the higher number is the recommended heart rate for aerobic exercise.

Fat Burning

To burn fat effectively, you must exercise at a relatively low intensity level for a sustained period of time. During the first few minutes of exercise, your body uses easily accessible *carbohydrate calories* for energy. Only after the first few minutes does your body

begin to use stored *fat calories* for energy. If your goal is to burn fat, adjust the speed and incline of the treadmill until your heart rate is near the lowest number in your training zone.

For maximum fat burning, adjust the speed and incline of the treadmill until your heart rate is near the middle number in your training zone.

Aerobic Exercise

If your goal is to strengthen your cardiovascular system, your exercise must be “aerobic.” Aerobic exercise is activity that requires large amounts of oxygen for prolonged periods of time. This increases the demand on the heart to pump blood to the muscles, and on the lungs to oxygenate the blood. For aerobic exercise, adjust the speed and incline of the treadmill until your heart rate is near the highest number in your training zone.

WORKOUT GUIDELINES

Each workout should include the following three parts:

A Warm-up—Start each workout with 5 to 10 minutes of stretching and light exercise. A proper warm-up increases your body temperature, heart rate and circulation in preparation for exercise.

Training Zone Exercise—After warming up, increase the intensity of your exercise until your pulse is in your training zone for 20 to 60 minutes. (During the first few weeks of your exercise program, do not keep your pulse in your training zone for longer than 20 minutes.) Breathe regularly and deeply as you exercise—never hold your breath.

A Cool-down—Finish each workout with 5 to 10 minutes of stretching to cool down. This will increase the flexibility of your muscles and will help prevent post-exercise problems.

EXERCISE FREQUENCY

To maintain or improve your condition, complete three workouts each week, with at least one day of rest between workouts. After a few months, you may complete up to five workouts each week if desired. The key to success is to make exercise a regular and enjoyable part of your everyday life.

PART LIST—Model No. 831.24646.1

R1106A

To locate the parts listed below, see the EXPLODED DRAWING on pages 24 to 27.

Key No.	Qty.	Description	Key No.	Qty.	Description
1	2	Foot Rail Cover	49	1	Walking Platform
2	6	3/4" Screw	50	1	Incline Motor/Controller Wire
3	35	Screw	51	1	Rear Roller
4	1	Reset/Off Circuit Breaker	52	1	Left Rear Endcap
5	8	Foot Rail Screw	53	2	Rear Roller Bolt
6	4	Isolator	54	1	Right Rear Endcap
7	9	Hood Screw/Tie Screw	55	1	Hex Key
8	2	Handrail Cap	56	1	Incline Stop Bracket
9	2	Platform Bolt, Back	57	1	Base Ground Wire
10	2	Platform Bolt, Front	58	1	Frame
11	4	Belt Guide Screw	59	1	Belly Pan
12	2	Belt Guide	60	2	Center Isolator
13	1	Power Cord Grommet	61	1	Reed Switch Clip
14	2	Front Endcap Screw	62	2	Handrail Endcap
15	2	Frame Pivot Bolt	63	1	Reed Switch
16	1	Left Foot Rail	64	4	Handrail Bolt
17	1	Right Foot Rail	65	2	2.5" Extension Leg Bolt
18	1	Motor Pivot Pin	66	2	Rear Roller Washer
19	1	Motor Bracket	67	2	Extension Leg Nut
20	2	Handrail	68	2	Caution Decal
21	1	Latch Pin Assembly	69	1	Warning Decal
22	2	Motor Washer	70	2	Platform Nut
23	1	Motor Star Washer	71	10	Cable Tie
24	2	Motor Bolt	72	3	Belly Pan Screw
25	2	Motor Tension Bolt	73	1	Latch Housing
26	1	Motor Belt	74	2	Tie Clamp
27	1	Drive Motor	75	1	Releasable Tie
28	2	Frame Spacer	76	1	Access Door
29	4	U-nut	77	1	Wire Harness
30	2	Motor Nut	78	2	Extension Leg Endcap
31	2	Lift Frame Bolt	79	1	Key/Clip
32	6	Lock Nut	80	2	Front Wheel
33	9	Ground Screw	81	2	Wheel Pin
34	1	Console	82	2	Base Pad
35	2	Fan Screw	83	4	1" Tek Screw
36	1	Power Cord	84	1	Upright
37	1	Console Fan	85	1	Console Base
38	1	Controller	86	2	Incline Motor Bolt
39	1	Electronic Bracket	87	1	Hair Pin Cotter Pin
40	1	Filter Wire	88	1	Incline Motor
41	1	Hood	89	2	Extension Leg
42	2	Handrail Bracket	90	2	Rear Roller Bracket
43	1	Lift Frame	91	2	Extension Leg Base Pad
44	2	Front Endcap	92	2	2.25" Extension Leg Bolt
45	1	Front Roller Bolt	93	1	Optic Disk
46	1	Magnet	94	1	Photo Switch Nut
47	1	Front Roller	95	2	Small Star Washer
48	1	Walking Belt	96	1	Photo Switch

Key No.	Qty.	Description	Key No.	Qty.	Description
97	1	Photo Switch Bolt	111	1	Console Ground Wire
98	2	Dumbbell	112	1	Large Belly Pan Screw
99	1	Latch Plate	113	3	Hood Clip
100	3	Wire Tie	#	1	4" Blue Wire, 2F
101	1	Roller Ground Wire	#	1	10" Red Wire, M/F
102	1	Photo Switch Wire	#	1	12" Blue Wire, 2F
103	2	Isolator Bracket Cover	#	1	8" Black Wire, M/F
104	2	Center Isolator Bolt	#	1	12" Blue Wire, M/F
105	2	Rear Roller Lock Washer	#	1	User's Manual
106	4	Crossbar Screw			
107	4	Crossbar Star Washer			
108	1	Front Roller Nut			
109	1	Crossbar			
110	1	Fan Cover			

#These parts are not illustrated
Specifications are subject to change without notice.
If a part is missing, call toll-free 1-888-533-1333.

EXPLODED DRAWING B—Model No. 831.24646.1

R1106A

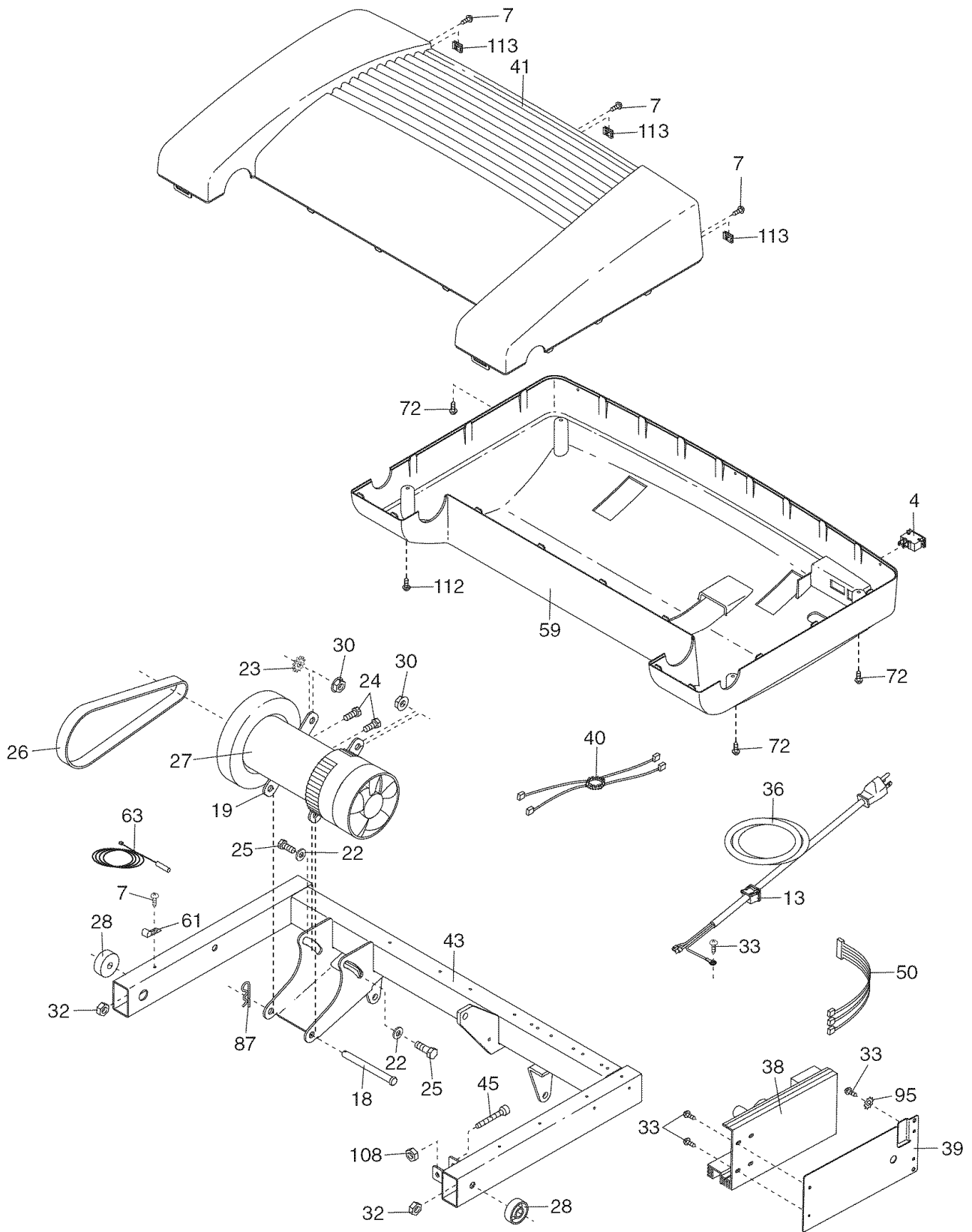

EXPLODED DRAWING C—Model No. 831.24646.1

R1106A

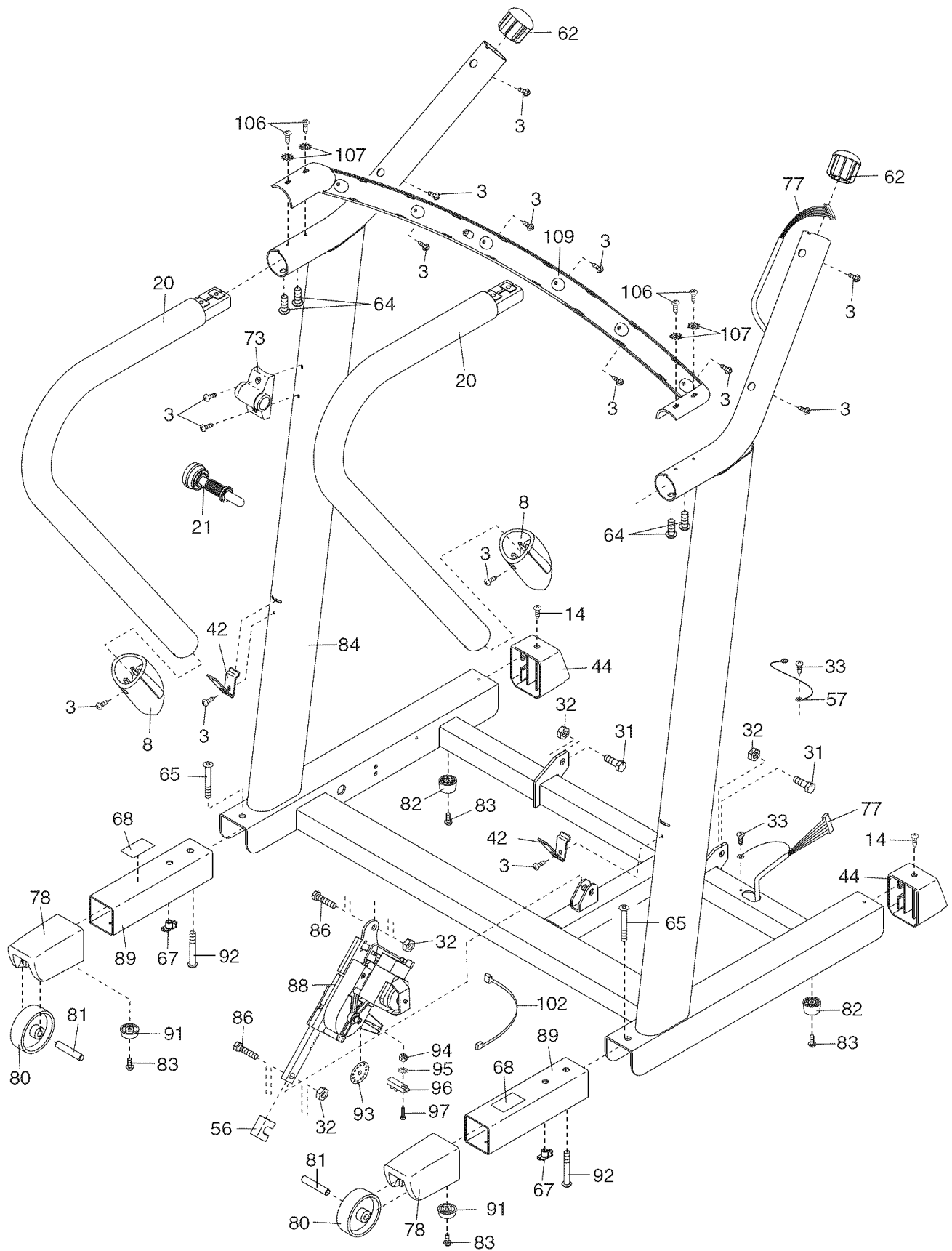

EXPLODED DRAWING D—Model No. 831.24646.1

R1106A

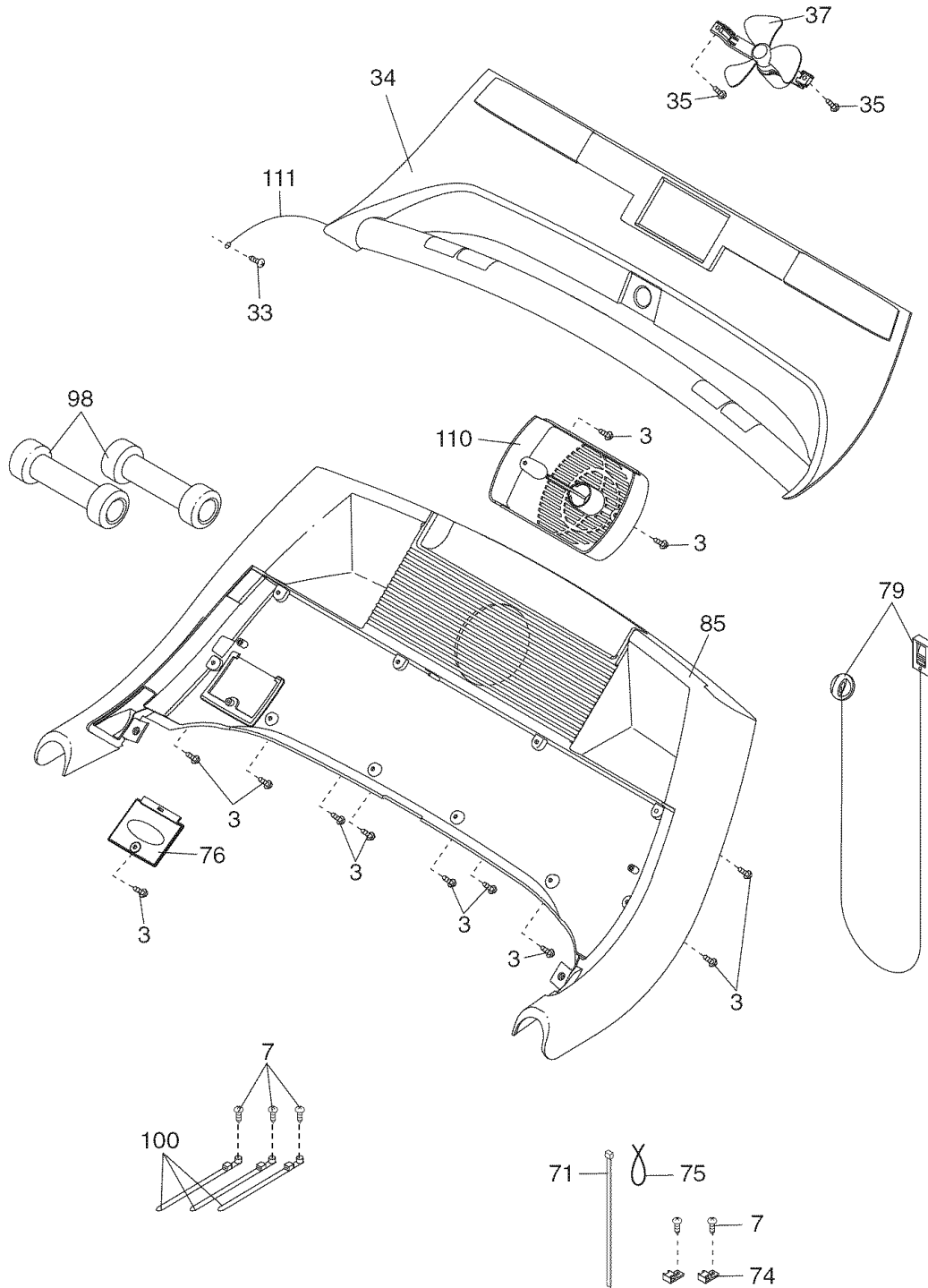

Get it fixed, at your home or ours!

Your Home

For repair—**in your home**—of **all** major brand appliances, lawn and garden equipment, or heating and cooling systems, **no matter who made it, no matter who sold it!**

For the replacement parts, accessories, and user's manuals that you need to do-it-yourself.

For Sears professional installation of home appliances and items like garage door openers and water heaters.

1-800-4-MY-HOME® (1-800-469-4663)

Call anytime, day or night (U.S.A. and Canada)

www.sears.com

www.sears.ca

Our Home

For repair of carry-in items like vacuums, lawn equipment, and electronics, call or go on-line for the location of your nearest **Sears Parts & Repair Center.**

1-800-488-1222 Call anytime, day or night (U.S.A. only)

www.sears.com

To purchase a protection agreement (U.S.A.) or maintenance agreement (Canada) on a product serviced by Sears:

1-800-827-6655 (U.S.A.)

1-800-361-6665 (Canada)

Para pedir servicio de reparación a domicilio, y para ordenar piezas:

1-888-SU-HOGAR® (1-888-784-6427)



® Registered Trademark / ™ Trademark / ™ Service Mark of Sears Brands, LLC
© Marca Registrada / ™ Marca de Fábrica / ™ Marca de Servicio de Sears Brands, LLC

90 DAY FULL WARRANTY

If this Sears Treadmill Exerciser fails due to a defect in material or workmanship within 90 days of the date of purchase, call 1-800-4-MY-HOME® (1-800-469-4663) to arrange for free repair (or replacement if repair proves impossible). The drive motor is warranted for 12 years from the date of purchase.

This warranty does not apply when the Treadmill Exerciser is used commercially or for rental purposes.

This warranty gives you specific legal rights, and you may also have other rights which vary from state to state.

Sears, Roebuck and Co., Hoffman Estates, IL 60179