



# 12,000 BTU Evaporative Portable Air Conditioner

Owner's Manual  
Model # KY-32E



**Please read owner's manual carefully before operating the unit.**

## TABLE OF CONTENTS

	PAGE
Table of Contents .....	2
Introduction .....	3
Important Safeguards .....	4
LCDI Power Cord and Plug.....	5
Package Contents .....	6
Parts Diagram .....	6
Assembly Requirements .....	8
Control Panel and LCD Screen.....	9
Operation Using the Control Panel.....	11
Operation Using the Remote Controller.....	12
Optional Water Drainage .....	14
Proper Care and Maintenance.....	15
Troubleshooting .....	16
Technical Specifications .....	17
Contact Information .....	17
Warranty .....	18

## INTRODUCTION

Thank you for purchasing the Soleus Air KY-32E 12000 BTU Portable Evaporative Air Conditioner. This unit is designed to improve living and working comfort by providing cooling, dehumidifying and fan functions with minimal installation.

This multi-functional portable air conditioner operates as an air conditioner, dehumidifier, and fan. Unlike traditional portable air conditioners, there is no bucket to empty. The condensate water is evaporated and removed through the exhaust duct along with warm exhaust air. At 12000 BTUs the KY-32E is one of the most powerful portable air conditioners on the market. In addition, the high speed motor allows for operation in high temperatures. Soleus Air "Smart Chip" technology and precise control of the unit.

When operating as an air conditioner, this unit is designed for spot cooling or cooling a room no larger than 450 square feet with a standard eight foot ceiling height. Please read these instructions carefully before operating this appliance. When using this air conditioner, always exercise basic safety precautions.

This easy-to-use manual will guide you in obtaining the best use of your Portable Air Conditioner. Please complete the following information for future reference. You will need it to obtain warranty service.

Model Number: KY-32E

Serial Number \*: \_\_\_\_\_

Date of Purchase: \_\_\_\_\_

Place of Purchase: \_\_\_\_\_

\*The Serial number is located on the back of the unit. Retain this Owner's Manual with your sales receipt as a permanent record of your purchase.

### Customer Service:

1-888-876-5387

9451 Telstar Avenue

El Monte, California 91731

[www.soleusair.com](http://www.soleusair.com)

## IMPORTANT SAFEGUARDS

Before installing and using the portable air conditioner, please read this Owner's manual carefully.

1. Never use or store gasoline or other flammable vapor or liquid near this unit.
2. Maintain at least 20" (50cm) clearance space around all side of the unit. Do not obstruct air inlet or outlet grilles.

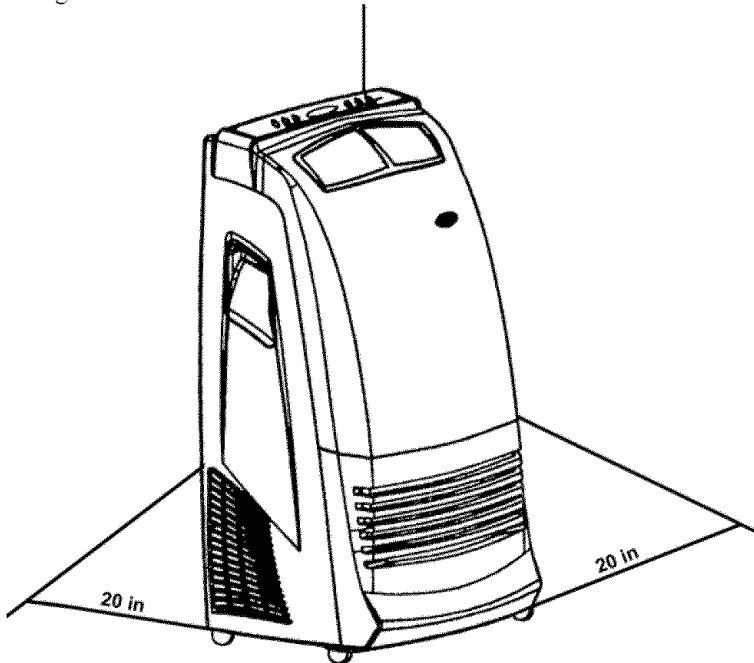

3. All in-home wiring must comply with local and national codes and be installed by a qualified technician. All wiring problems should be resolved by a qualified technician BEFORE installation and use of this air conditioner.
4. The power supply must be properly grounded.
5. For your safety, this unit is grounded through the power cord plug when connected to a matching wall outlet. Do not use an adapter plug or extension cord.
6. When removing the power cord from the wall outlet, always grasp the plug firmly and pull straight from the outlet. Never unplug the air conditioner by pulling on the cord itself.
7. Always inspect the power cord and plug for signs of damage before use.
8. Repair or replace immediately, all power cords that have become frayed or otherwise damaged. Do not use a cord that shows cracks or abrasion damage along its length, the plug or the connector end.
9. Do not use the unit in the immediate surroundings of a bath, a shower or a swimming pool. Never immerse the unit in water or any other liquid.
10. Keep out of reach of children.
11. Use product only as directed in this manual; unintended use may void the warranty.

NOTE: If for any reason this product requires service, we strongly recommend that a certified technician perform the service.

## LCDI POWER CORD AND PLUG

This air conditioner is equipped with an LCDI (Leakage Current Detection and Interruption) power cord and plug as required by US National Electric Code 440.65. This cord consists of a length of shielded flexible cord with no termination on the load side and a LCDI attachment plug on the line side.

The LCDI power cord and plug will remove the supply source via electrical disconnect (circuit trip) if the nominal current leakage between the cord shield and either load conductor exceeds a predetermined value. The cord will remain de-energized until the device has been manually reset. This is intended to reduce the risk of a fire in the power cord or combustible materials nearby. The cord shields are not grounded and they must be considered a shock hazards if exposed. The cord shield must not be connected to ground or to any exposed metal.

The test and reset buttons on the LCDI Plug are used to check if the plug is functioning properly. To test:

1. Plug power cord into wall outlet
2. Press TEST Button, circuit should trip, cutting power to the air conditioner
3. Press RESET button for use

If a test is performed and the indicator light remains ON, current leakage has been detected. Do not use the air conditioner or attempt to reset the LCDI Plug. Contact Soleus Air Customer Service for troubleshooting recommendations.

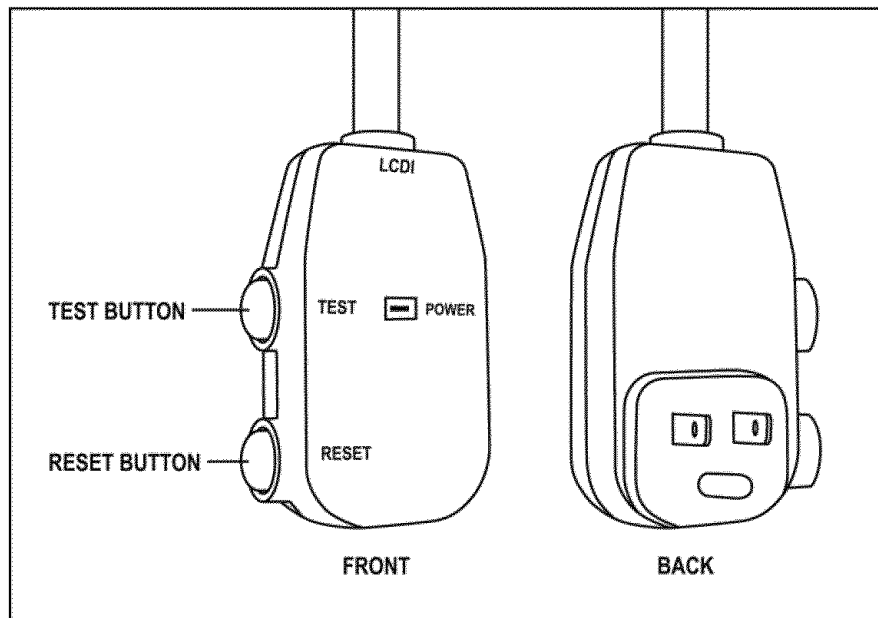

### WARNING:

1. DO NOT press TEST button while the air conditioner is operating.
2. The TEST and RESET buttons should not be used as "ON" and "OFF" switches.
3. The cord and plug are not intended to offer protection to externally connected loads or supply circuits.
4. The cord and plug are intended for indoor use only.

## PACKAGE CONTENTS

1. Portable Air Conditioner
2. Air Exhaust Duct
3. Exhaust Duct Window Kit Adapter
4. Remote Control
5. AAA Batteries (2)
6. Window Kit - 3 Sliding Panels
7. Window Kit Fastener Screws (4)
8. Continuous Drainage Tube
9. Exhaust Outlet Wall Cover
10. User's Manual

## PARTS DIAGRAM

### FRONT VIEW

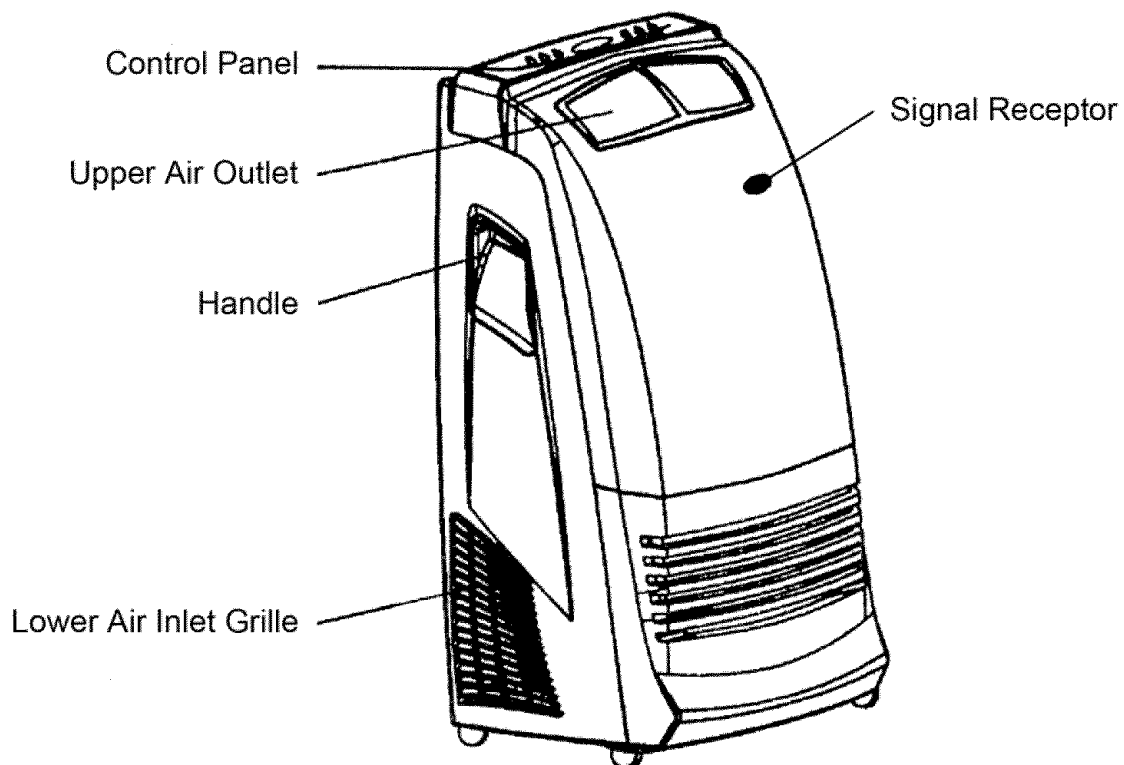

## REAR VIEW

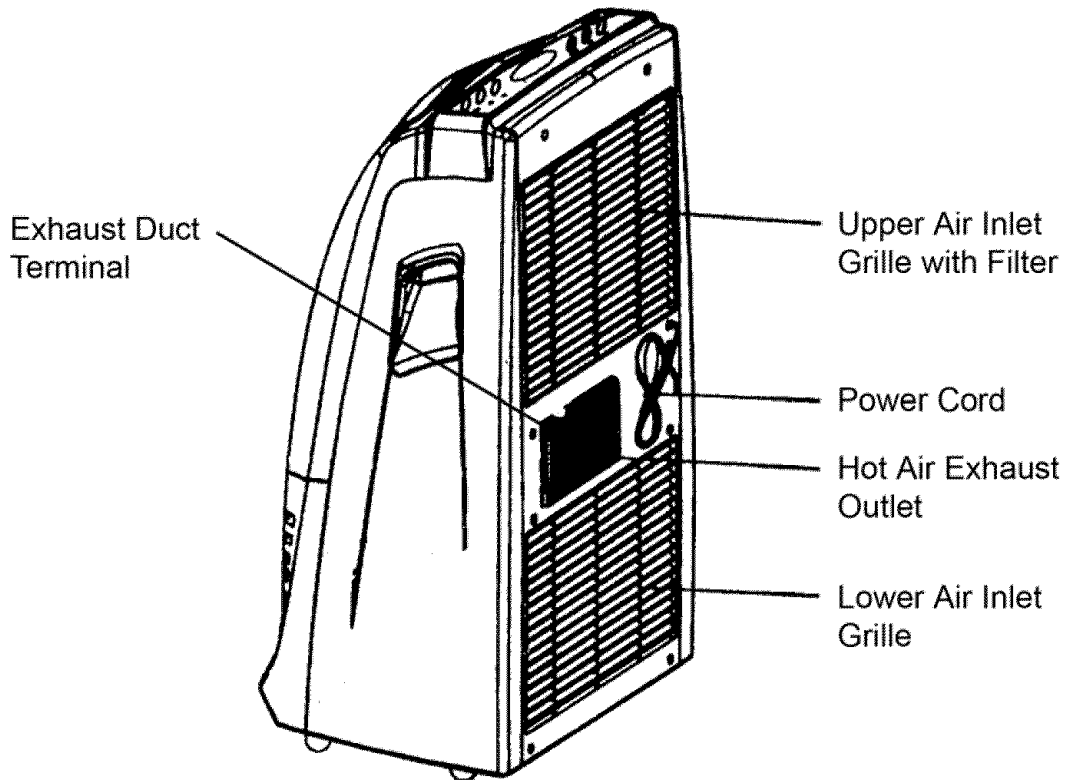

## WINDOW KIT

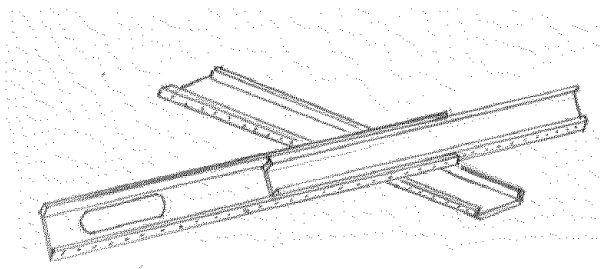

## EXHAUST DUCT

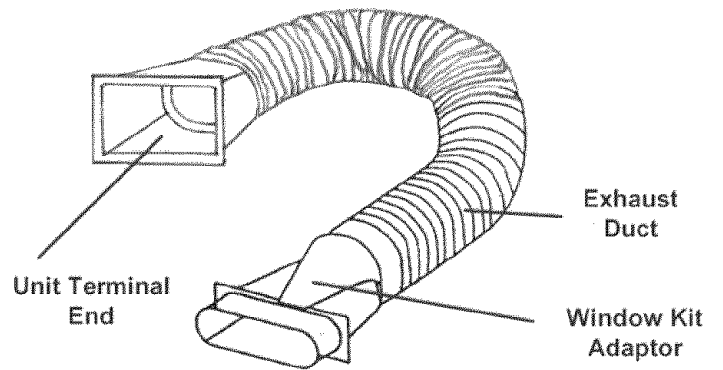

## ASSEMBLY REQUIREMENTS

### EXHAUST DUCT

When you use the unit as an air conditioner, the hot exhaust air and evaporated condensate water must be vented out of the room. The exhaust duct and venting kit serves this purpose.

NOTE: The exhaust duct and venting kit should not be used while the unit is operated in dehumidification, or fan mode. DO NOT INSTALL EXHAUST DUCT WHILE UNIT IS IN OPERATION.

- a) Slide “Unit Terminal End” of the exhaust connector completely over the “Hot Air Outlet Grill” on the rear of the unit. Plastic grooves are located on the hot air outlet help to guide the exhaust connector into place.

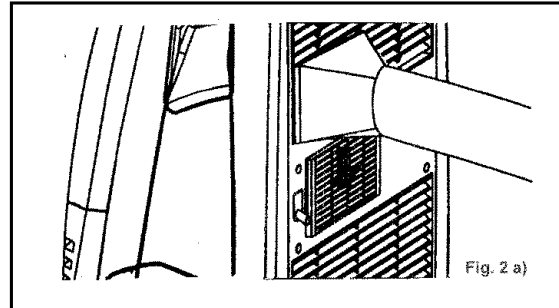

- i. Window Kit Mounting: The exhaust hose easily connects to the window kit by snapping the hose adapter directly onto the kit. See page 7 for window/sliding door kit installation.

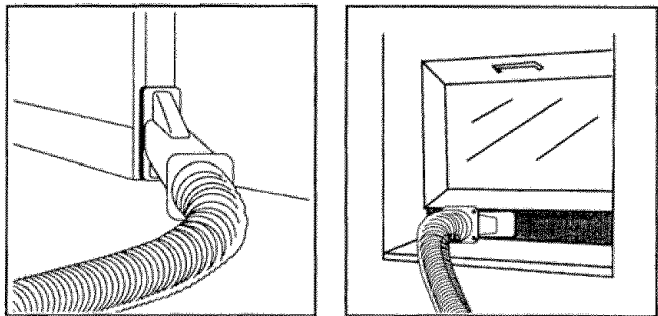

- ii. Wall Mounting: Mount the external end of the exhaust duct to a 5/4” hole within the wall. Creating a hole into a wall is a separate procedure that may require professional installation.

**NOTE: Correct Mounting is shown to the right, The center height of the hole should be between 16”-50”**

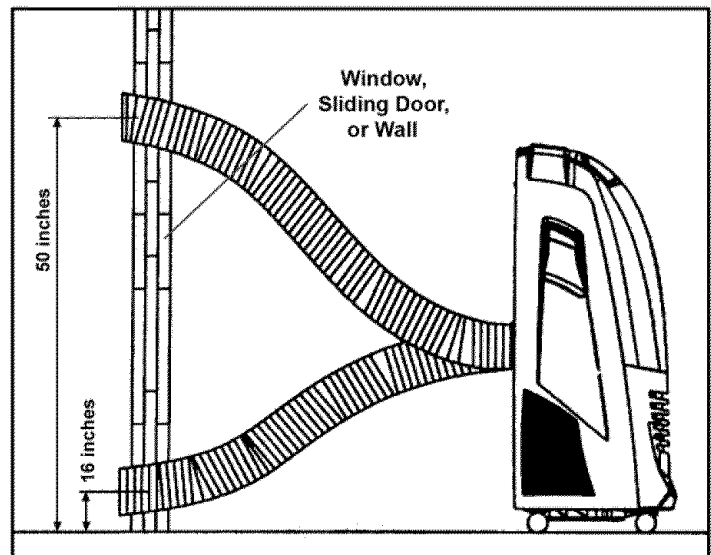



NOTE: In order to achieve maximum room cooling efficiency, the exhaust duct should remain as short and straight as possible. To further shorten the exhaust hose, first unthread either exhaust duct adapter clockwise to remove it. Then cut the hose to desired length. It is not recommended to increase the manufacturer's length of the exhaust hose. This may reduce the cooling efficiency or damage the unit.

## WINDOW KIT INSTALLATION

- Open window or sliding door approximately 5 inches (13 cm). Adjust the length of the window kit to the same length of the window or sliding door. Use two or three panels if necessary and secure panels into place by fastening the  $\frac{3}{4}$ " Phillips head screws into the pre-drilled panel holes.
- Alternatively you may need to mark a single panel and cut it down to properly fit the window opening. The window kit (three panels) has a maximum length 81 inches.
- Place the window kit between the window and the window frame as shown in the picture to the right. Close the window onto the window kit to form a tight seal.
- Attach the exhaust duct window kit adapter to the window kit. Tabs located on the adapter will lock into place securing the adapter to the window kit.

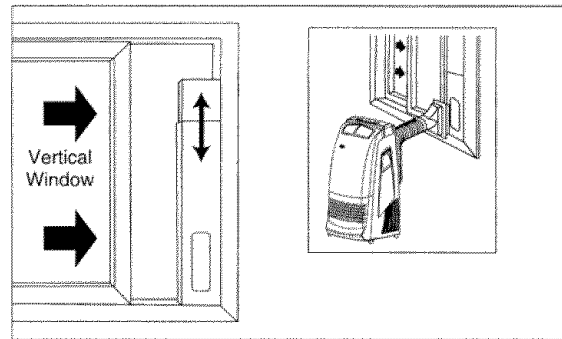
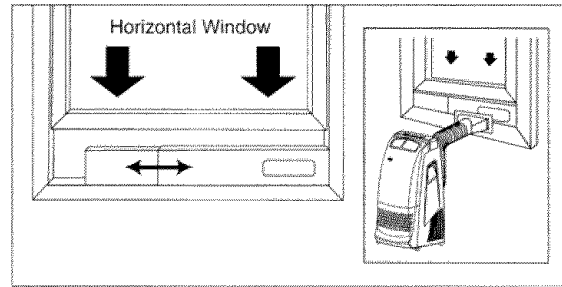

NOTE: Using the window kit will cause the window not to be properly closed and locked. Consider taking additional security measurements.

## CONTROL PANEL AND LCD SCREEN

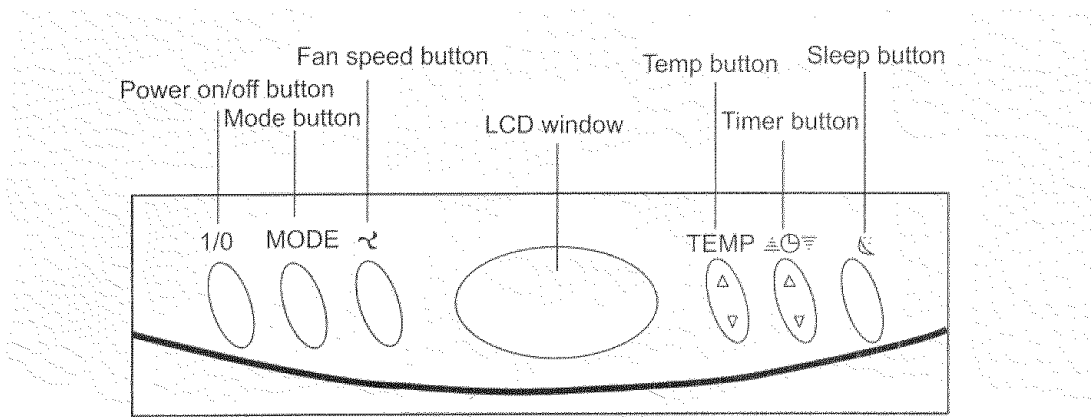



## CONTROL PANEL FUNCTIONS

1. Power On/Off Control  
Starts or stops the unit.

2. Temperature Setting Control  
Select the desired temperature setting by pressing either the ▲ ▼ buttons. It is recommended to set the temperature before selecting the Mode Control.

3. Mode Control  
Select the functions of the unit for:

Air Conditioning Mode 

Dehumidifying Mode 

Fan Mode 

Auto Mode 

4. Fan Speed Control  
Select the fan speed for:

Low  
Medium  
High

5. Timer Function  
Set timer to start or stop the unit.

When the unit is On, press “Timer” Button repeatedly until the desired number of hours is displayed in the lower right corner of the display window. The unit will automatically power Off once the selected number of hours has elapsed.

When the unit is Off, press “Timer” Button repeatedly until the desired number of hours is displayed in the lower right corner of the display window. The unit will automatically power On once the selected number of hours has elapsed.

NOTE: The timer function must be manually reset before each automatic start or stop.

6. Sleep Function  
The sleep function is designed to automatically adjust the temperature upwards according to the amount of time elapsed (adjustable from 0.5 to 7.0 hours). This saves power while still keeping the room temperature at a comfortable level.

## LCD DISPLAY

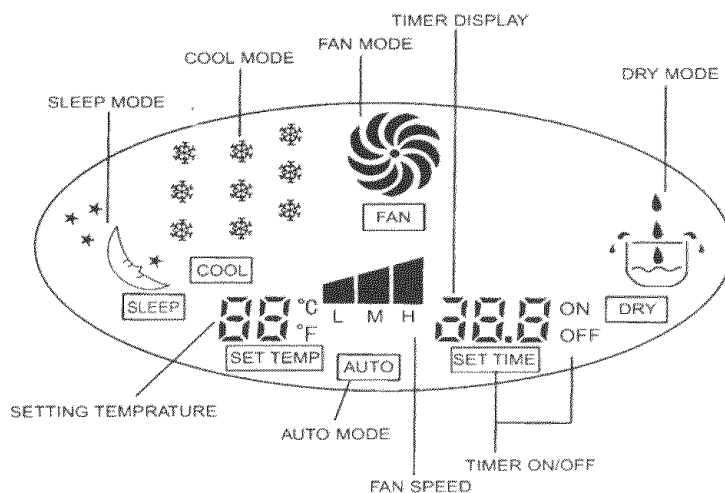

## OPERATION USING THE CONTROL PANEL

### COOLING OPERATION

1. Ensure the exhaust duct properly installed. Refer to page 8 for exhaust duct installation.
2. Plug the Power Cord to the power outlet.
3. Turn on the unit by pressing the Power Button on the control panel.

#### Manual Mode:

Press the Mode Button repeatedly until  appears on the LCD display.

Press the Temperature Buttons up or down until the desired room temperature appears on the LCD. The temperature ranges from 61-86 °F (16 °-30°C).

Press the Fan Button to select low, medium or high speed.

#### Auto Mode:

Press the Mode Button repeatedly until the word "Auto" appears on the LCD display. In the Auto Mode, the "Smart Chip" microprocessor controls the temperature and fan speed for optimal comfort.

NOTE: The fan speed cannot be adjusted in dehumidifying mode.

NOTE: During hot days, the unit will cool off the room most efficiently by setting the temperature to the lowest setting and the fan speed to the highest setting. Reducing the length of the exhaust duct, insulating the exhaust duct and keeping direct sunlight to a minimum will also improve the cooling efficiency.

### DEHUMIDIFIER OPERATION

1. If exhaust duct is attached, remove it from the rear of the air conditioner.
2. Plug the Power Cord to the power outlet.
3. Turn on the unit by pressing the Power Button on the control panel.
4. Press the Mode Button repeatedly until  appears on the LCD display.

NOTE: The fan speed cannot be adjusted in dehumidifying mode.

NOTE: Do not use the exhaust duct when the unit is running at dehumidifying mode. You must remove the exhaust duct from the unit. When the unit is running at dehumidifying mode, the fan speed cannot be adjusted. Keep the windows and the doors closed to aid the efficiency of the unit in removing the moisture from the room.

## FAN OPERATION

1. Plug the Power Cord to the power outlet.
2. Turn on the unit by pressing the Power Button on the control panel.
3. Press the Mode Button until  appears on the LCD display.
4. Press the Fan Button to select Low, Medium or, High speed.

## OPERATION USING REMOTE CONTROLLER

The remote control provided with the unit operates this portable air conditioner. The remote control uses (2) AAA batteries (provided). Install the batteries before using the remote controller.

NOTE: The information displayed on the LCD of the remote controller will only be transmitted to the air conditioner when the 1/0, Send, or Sleep buttons (transmitting buttons) are pressed. Any changes made to the LCD display will be reversed to the previous setting if none of the transmitting buttons are pressed within 15 seconds after the changes are made.

NOTE: When the remote controller is off, the LCD only displays the current time.

## REMOTE CONTROLLER

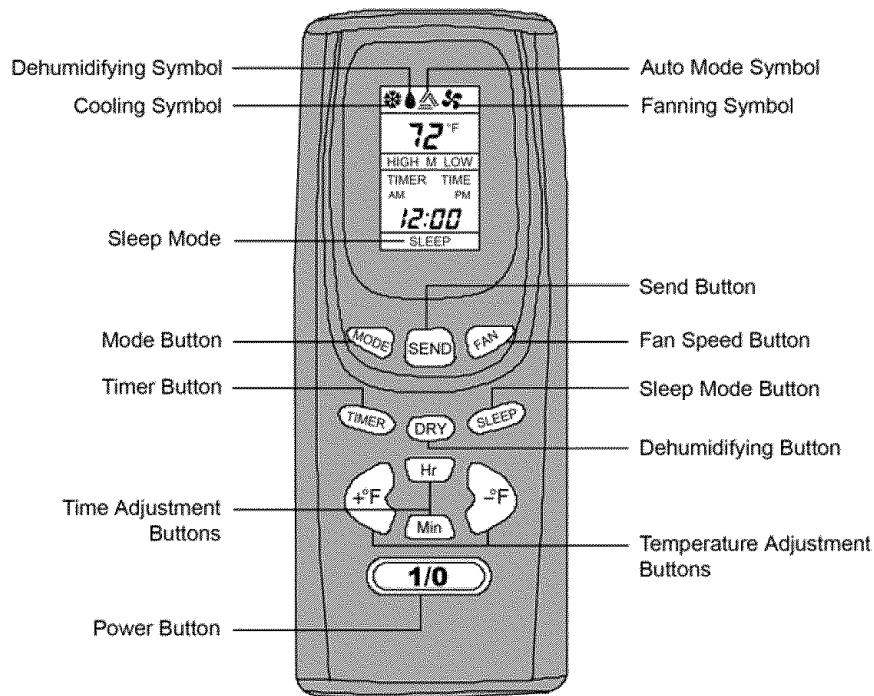

## SETTING THE CLOCK

1. Press I/O button to turn on the remote control.
2. Press the Hr and Min buttons until the LCD displays the correct time.
3. Press the Send button to set time.

## COOLING OPERATION

1. Press the I/O button to turn on the remote control.
2. Press the Mode button until the LCD displays the cooling symbol.
3. Press either +°F or -°F button until the LCD displays the desired temperature. Each press will increase or decrease the set temperature by 1°F.
4. Press the Fan button until the LCD displays the desired fan speed.
5. Press the Send button.

## DEHUMIDIFYING OPERATION

1. Press the I/O button to turn on the remote controller.
2. Press the Dry button. The dehumidifying symbol will appear on the LCD display.
3. Press either +°F or -°F button until the LCD displays the desired temperature.
4. Press the Fan button until the LCD displays the desired fan speed.
5. Press the Send button.

## FAN OPERATION

1. Press the I/O button to turn on the remote controller.
2. Press the Mode button until the LCD displays the fan symbol.
3. Press the Fan button until the LCD displays the desired fan speed.
4. Press the Send button.

## AUTO MODE

1. Press the I/O button to turn on the remote controller.
2. Press the Mode button until the LCD displays the auto symbol.
3. Press the Send button.

## TIMER

1. Press the I/O button to turn on the remote control.
2. Press the Timer button. "TIMER" will appear on the LCD display.
3. Press the Hr button until the LCD displays the desired number of hours for the operation. When the set time has elapsed (from 0.5 to 24 hrs), the unit will automatically shut off.
4. Press the Send button.

NOTE: The unit can also be programmed to automatically start after a set period of time in Sleep Mode.

## SLEEP MODE

1. Press the I/O button to turn on the remote control.
2. Press the Mode key to select the desired operation.
3. Press the +°F or -°F button until the LCD displays the desired temperature.
4. Press the Fan button until the LCD displays the desired fan speed.
5. Press the Send button.
6. Press the Sleep button. "Sleep" will appear on the LCD display.
7. To set the auto start time, press the Hr button until the desired number of hours until auto start is displayed.
8. Press the Send button. The unit will automatically start after the set number of hours (from 1 to 7 hrs).

## OPTIONAL WATER DRAINAGE

When operating the air conditioner in cooling or dehumidifying mode under normal conditions, the condensation water is automatically evaporated from an internal drip pan out through the exhaust duct. Under extremely high humidity conditions, the water in the drip pan may reach a level that triggers a shut-off mechanism. The compressor and fan will turn off and the water must be drained via one of the following two methods.

### CONTINUOUS DRAINAGE

When the unit is operating on continuous drainage mode, excess condensation in the drip pan is discharged by gravity through the drainage tube to either an external tank (not provided) or to a condensation water pump device (Optional Item). When the unit is operating on continuous drainage mode, it can operate continuously regardless of humidity level.

Installation Steps:

- a. Remove the plug from the drainage spout.
- b. Connect the drainage tubing to the drainage spout.
- c. Place the other end of the drainage tube into either an external water tank or the inlet side of a condensation water pump.

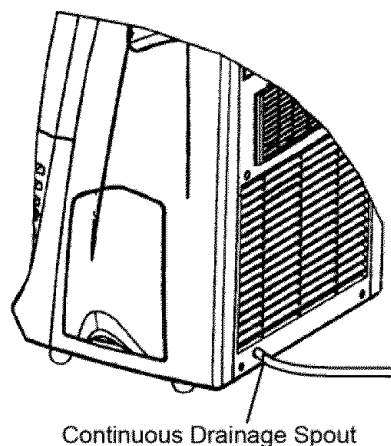

#### NOTE:

Do not use lengthy drainage tubing without a condensation water pump

## MANUAL DRAINAGE

When the unit is operating in manual drainage mode, excess condensation in the drip pan will rise until it reaches a predetermined level, at which time the air conditioner will signal a warning (E4 on LCD) and shut off. To drain the excess condensation, turn off the air conditioner, remove the drain plug and allow water to drip into an external pan or drainage tubing.

**WARNING:** Do not operate the air conditioner without the drain plug unless the drainage tube is directed to an external drain or bucket. Dripping water may damage wood floors and carpet and may also cause injury if not properly contained.

## PROPER CARE AND MAINTENANCE

Note: To avoid electrical shock, always turn off and unplug your air conditioner before cleaning or performing maintenance activities. Ignoring this warning may result in injury.

### CLEAN OR REPLACE FILTER

1. Push down the two tabs on the filter cover and pull outwards to remove the entire filter and cover.
2. Unhook the air filter from the plastic hooks. Keep and set aside the clear plastic tabs for reassembly.
3. Wash the air filter by immersing it gently into warm (about 104 F) water. Use a mild cleanser and dry it thoroughly if necessary.
4. Attach the filter to the filter cover with the attachment hooks on the inside surface of the cover.
5. Place the bottom of the filter cover into the holes in the unit case. Push the cover back into the original position.
6. If the filter is torn or unusable, order a new filter by calling the customer service telephone number listed in the contact section of this manual.

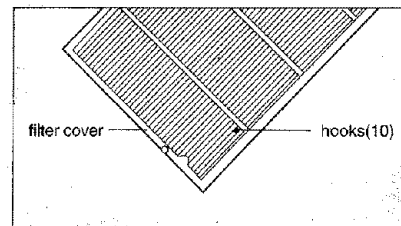
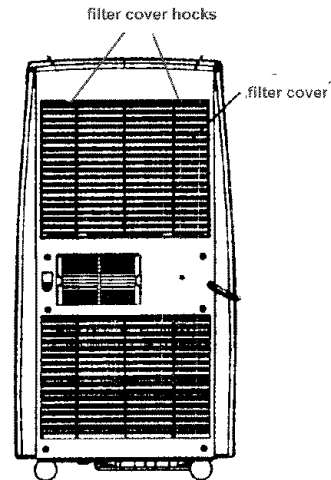

## CASE

1. Avoid direct exposure to sunlight as case color may fade.
2. Clean surface area with a damp cloth. Dry with a soft towel.
3. Vacuum grill inlets with a soft brush attachment.

NOTE: Do not use abrasive cleaning products on the case.

## STORING THE UNIT FOR AN EXTENDED PERIOD OF TIME OR TRANSPORTING

1. Unplug the unit from the power outlet.
2. Ensure that the water bucket is empty.
3. If using continuous drainage, disconnect any external drain hose and cap the end of the internal drain tube.
4. Store and transport unit in an upright position in a cool dry place.

## TROUBLESHOOTING

PROBLEM	POSSIBLE CAUSE	REMEDY
Unit does not operate	Unit is unplugged	Securely plug receptacle into the power outlet
	Air exhaust is clogged	Remove obstruction from exhaust hose
	Timer is on	Cancel the timer
Unit does not cool room	There is a heating source in the room	Turn other heating source off or down
	Temperature setting is too high	Decrease temperature setting
	Air filter is dirty	Clean or replace the air filter
	Air exhaust is not installed correctly	Check the exhaust duct to make sure that the hot exhaust air is being vented out of the room
	Room is too big or too much ambient sunlight is reaching in	This unit provides spot cooling or cooling for a room no larger than 450 square feet with standard ceiling height
In dehumidifying mode, no cool air coming out	There is frost on the evaporator	The unit will defrost automatically and return to operation afterwards
	There is frost on the evaporator	The unit will defrost automatically and will return to operation afterwards
Noise or vibration	Surface is not level	Place unit on a level surface and away from obstructions
Water is leaking from unit	Surface is not level	Place unit on a level surface



## TECHNICAL SPECIFICATIONS

MODEL	KY-32E	
COOLING CAPACITY	12,000 BTU/HR	
DEHUMIDIFYING CAPACITY	95 PINTS/DAY	
POWER	COOLING	1300 W
AIR FLOW VOLUME	170 CFM	
POWER SOURCE	115 V / 60 HZ 12 AMP COOLING	
SOUND PRESSURE LEVEL	<56 db(A)	
OPERATING TEMP	61 F -95 F	
NET WEIGHT	99 lbs	
DIMENSIONS	PACKAGE	21 x 19 x 45 ½ In (WxDxH)
	ASSEMBLED	17 ¼ x 14 ¼ x 34 In (WxDxH)
REFRIGERANT	R22	
HIGH SIDE PRESSURE	358 PSI	
LOW SIDE PRESSURE	180 PSI	

## CONTACT INFORMATION

Contact Customer Service For: Replacement Parts  
Technical Support  
Warranty Claims  
Customer Service

Soleus International Inc.  
9451 Telstar Ave.  
El Monte, CA 91731  
USA  
(888) 876-5387  
[www.soleusair.com](http://www.soleusair.com)  
[contact@soleusair.com](mailto:contact@soleusair.com)

## **WARRANTY**

### ONE YEAR LIMITED WARRANTY

Soleus Air International Inc. warrants the accompanying Soleus Air KY-32E Soleus Air Portable Air Conditioner to be free of defects in material and workmanship for the applications specified in its operation instruction for a period of ONE (1) year from the date of original retail purchase in the United States or Canada.

If the air conditioner exhibits a defect in normal use, Soleus Air International Inc. will, at its option, either repair or replace it, free of charge within a reasonable time after the air conditioner is returned during the warranty period.

As a condition to any warranty service obligation, the consumer must present this Warranty Certificate along with a copy of the original purchase invoice.

#### THIS WARRANTY DOES NOT COVER:

- 1) Damage, accidental or other wise, to the air conditioner while in the possession of a consumer not caused by a defect in material or workmanship.
- 2) Damage caused by consumer misuse, tampering, or failure to follow the care and special handling provisions in the instructions.
- 3) Damage to the finish of the case, or other appearance parts caused by wear.
- 4) Filter.
- 5) Damage caused by repairs or alterations of the air conditioner by anyone other than authorized by Soleus Air International Inc.
- 6) Freight and Insurance cost for the warranty service.

ALL WARRANTIES, INCLUDING ANY IMPLIED WARRANTY OR MERCHANTABILITY ARE LIMITED TO ONE-YEAR DURATION OF THIS EXPRESS LIMITED WARRANTY. SOLEUS AIR INTERNATIONAL INC. DISCLAIMS ANY LIABILITY FOR CONSEQUENTIAL OR INCIDENTAL DAMAGES AND IN NO EVENT SHALL SOLEUS AIR INTERNATIONAL INC.'S LIABILITY EXCEED THE RETAIL VALUE OF THE AIR CONDITIONER FOR BREACH OF ANY WRITTEN OR IMPLIED WARRANTY WITH RESPECT TO THIS AIR CONDITIONER

Serial No