

Soleus Air®

OWNER'S MANUAL

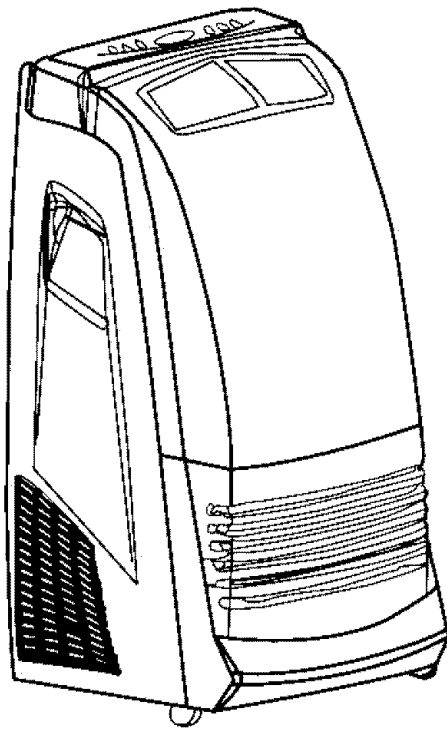

KY-32H

Portable Air Conditioner

- *Cooling*
- *Heating*
- *Dehumidifying*
- *Fan*

Please read this owner's
Manual carefully before
operating the unit.



TABLE OF CONTENTS

<u>INTRODUCTION</u>	3
<u>IMPORTANT SAFEGUARDS</u>	3
<u>PACKAGE CONTAINS:</u>	3
<u>NAMES OF PARTS</u>	4
<u>INSTALLATION BEFORE USE</u>	5
<u>CONTROL PANEL AND LCD DISPLAY</u>	7
<u>CONTROL PANEL FUNCTIONS</u>	8
<u>OPERATION USING CONTROL PANEL</u>	9
<u>OPERATION USING REMOTE CONTROLLER</u>	11
<u>CONDENSATE WATER DRAINAGE</u>	14
<u>MAINTENANCE</u>	16
<u>TROUBLESHOOTING</u>	17
<u>TECHNICAL SPECIFICATIONS</u>	18
<u>DISCLAIMER</u>	18
<u>CONTACT INFORMATION</u>	19
<u>WARRANTY</u>	20

INTRODUCTION

Thank you for purchasing the Soleus Air KY-32H portable air-conditioner. This unit is designed for improving living and working comfort by providing cooling, heating, dehumidifying and fan functions only with a minimum installation required. With its whisper quiet operation and attractive design, you will enjoy the convenience and comfort that this unit provides for many years to come.

When operating as an air conditioner, this unit is designed for spot cooling or cooling for a room no larger than 300 square feet with the standard ceiling height.

IMPORTANT SAFEGUARDS

Before you use your portable air conditioner, please read this operation manual carefully.

- 1) Never use or store gasoline or other flammable vapor or liquid near this unit.
- 2) Maintain at least 10" (25 CM) clearance space from this unit. Avoid air inlet or outlet grilles from being covered or closed off.
- 3) The power supply must be properly grounded.
- 4) Do not use an adapter plug or extension cord.
- 5) Do not use the unit in the immediate surroundings of a bath, a shower or a swimming pool.
- 6) Do not let children play near this unit.

PACKAGE CONTAINS:

Mobile Air Conditioner
Air Exhaust Duct
Exhaust Duct Window Kit Adapter
Remote Controller
AAA Batteries (2)
Window Kit - 3 Sliding Panels
Window Kit Fastener Screws (4)
Continuous Drainage Tubing Pipe
Exhaust Outlet Wall Cover
User Manual

NAMES OF PARTS

Front View

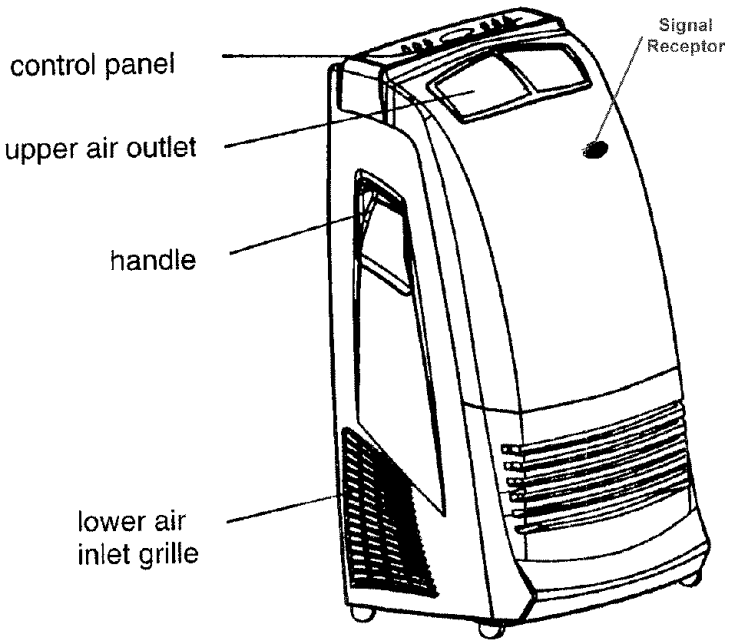

Back View

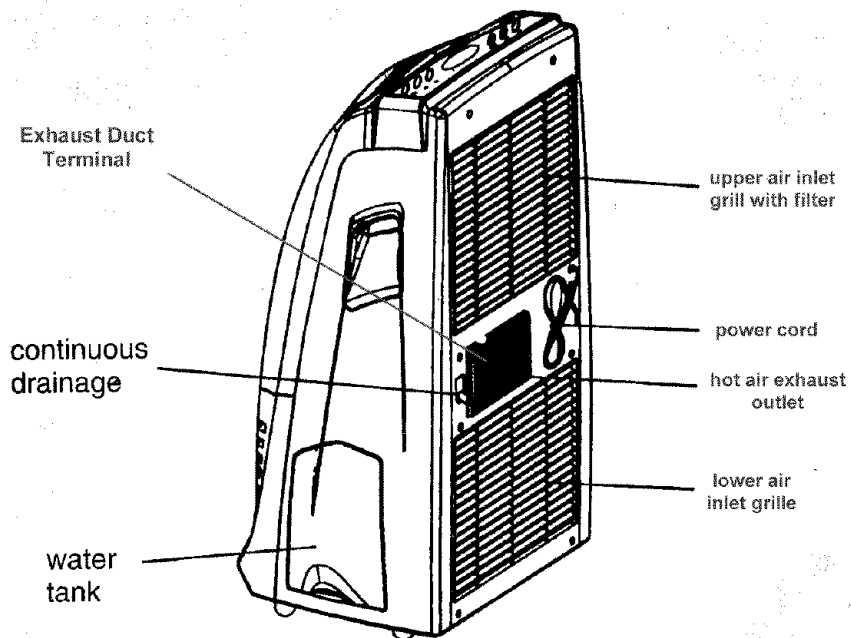

Exhaust Duct

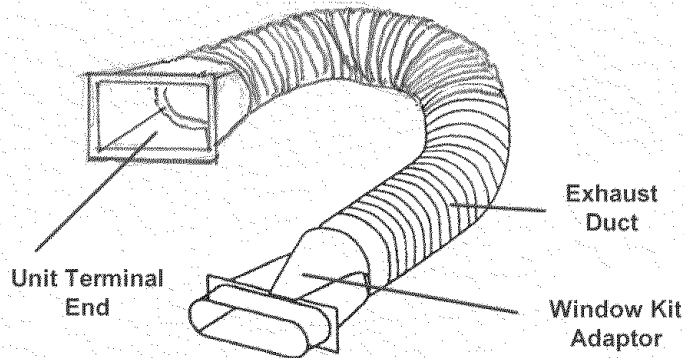

Window Kits

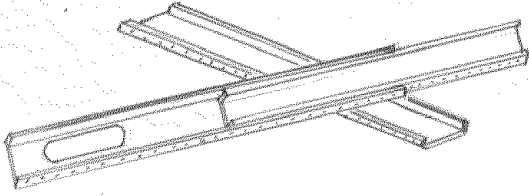

INSTALLATION BEFORE USE

1) Condensate Water Tank Float Lid

You must install the water tank float lid before first use of the portable air conditioner following these procedures:

- a) Hold the water tank and draw it out slowly.
- b) Remove water tank float lid and packing material from the water tank.

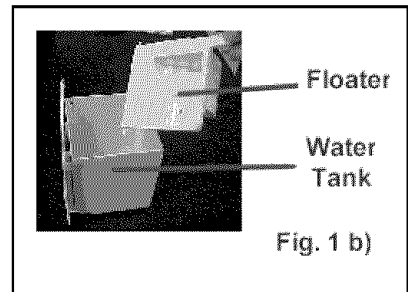

- c) Insert the float lid into the water tank by inserting one side of the hinge into the hinge holder on the water tank and then sliding the other side into its place.

The water tank float lid should be able to move up and down freely after correct installment.

- d) Insert the complete water tank back to the air conditioner unit.

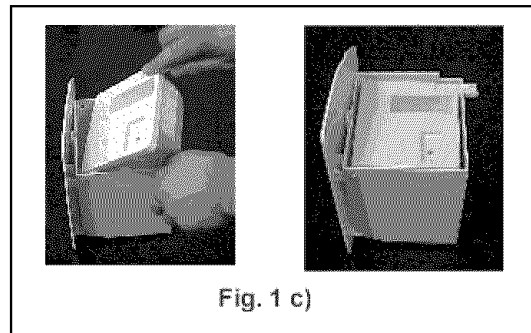

2) Exhaust Duct

When you use the unit as an air conditioner, the hot exhaust air must be directed out of the room. The exhaust duct is used to allow the hot air out. **DO NOT INSTALL OR USE THE EXHAUST DUCT WHEN THE UNIT IS OPERATED AS A DEHUMIDIFIER OR FAN.**

- a) Slid exhaust connector all the way down over the discharge opening of the unit.
- b) Mount the external end of the duct onto a hole of 5 1/4" (132 mm) on the wall for optional wall hot air installation, or
- c.) Connect the window kit adaptor to the external end of the exhaust duct for a window or sliding door hot air outlet installation.

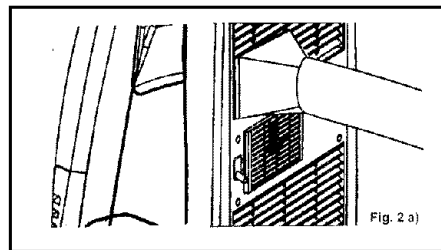

way down the unit.
exhaust mm) on the outlet

NOTE: In order to increase the efficiency, the exhaust duct should be kept as short and straight as possible. The exhaust hose can be cut shorter by unthreading either end of the exhaust duct counter clockwise. It is not recommended to increase the manufacturer's length of the exhaust hose. This may impede or damage the unit.

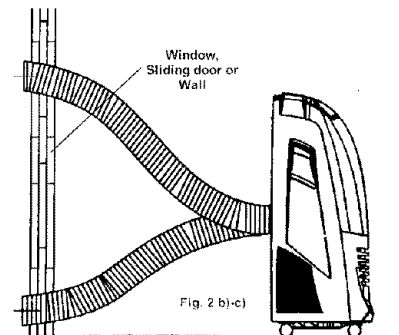

3) Window Kit Installation

- a) Open window or sliding door for approximately 5 inches (130 mm)
- b) Adjust the length of the window kit to the same length of the window or the sliding door. Use all three panels if necessary.
- c) Use screws to affix the window kit length.
- d) Place the window kit to the window or sliding door. Close the window or door as far as it goes.

- e) Mount the window kit extension of the exhaust host onto the window kit.
- f) Use screws on the window kit extension if necessary.

NOTE: When using the window kit on a window or sliding door it will cause the window or sliding door not to be properly closed and locked. Additional security measurements should be taken.

CONTROL PANEL AND LCD DISPLAY

CONTROL PANEL

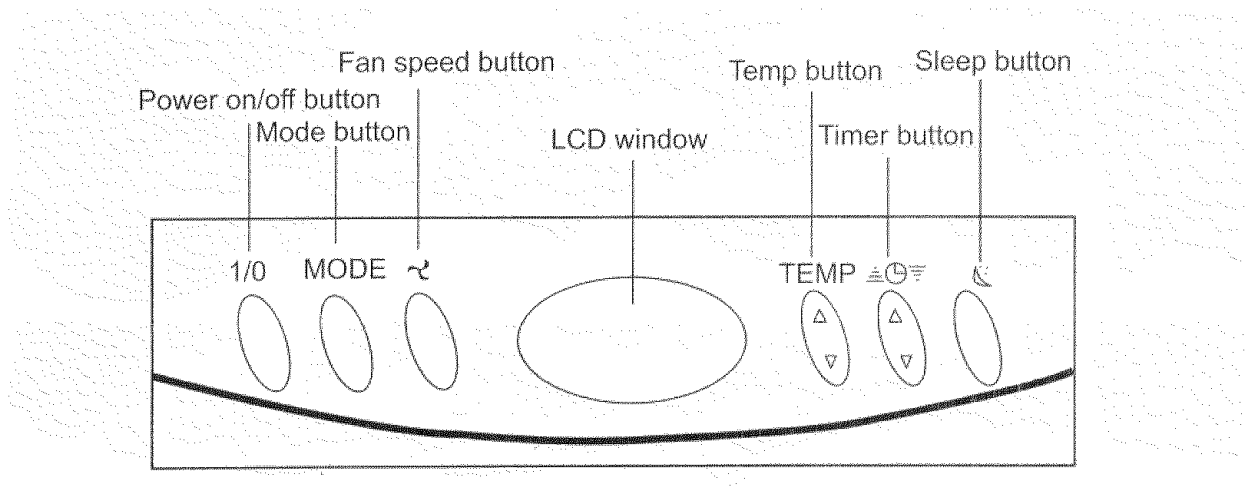

LCD DISPLAY

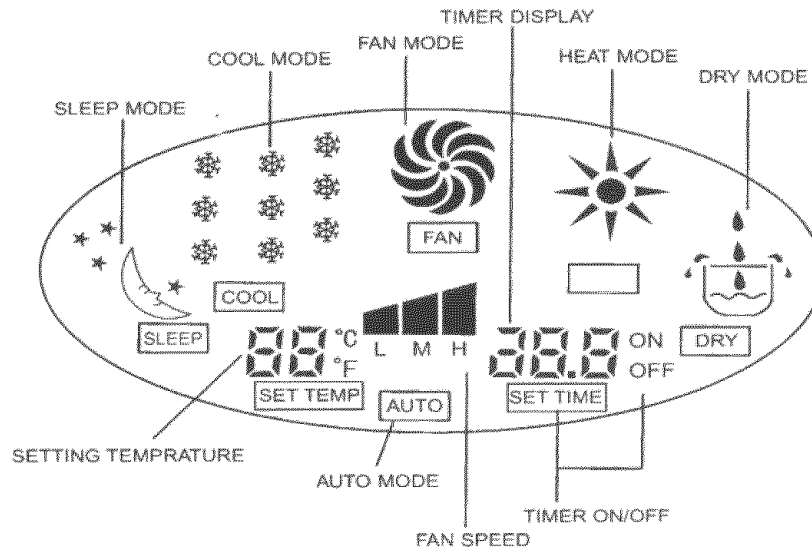

Control Panel Functions

- 1) Power On/Off Control
Starts or Stops the Unit

- 2) Mode Control
Select the functions of the unit for:
 - Fan Mode
 - Air Conditioning Mode
 - Heating Mode
 - Dehumidifying Mode
 - Auto Mode

- 3) Fan Speed Control
Select the fan speed for:
 - High
 - Medium
 - Slow

- 4) Temperature Setting Control
Select the desired temperature setting by pressing either ^ or v key when using the unit in cooling function. It is recommended to set the temperature before selecting the operational mode.

- 5) Timer Control
Set time to start or to stop the unit. When the unit is running, the timer will shut off the unit in the number of hours set. When the unit is off, the timer will start the unit in the

number of hours set. (0.5 – 24 hours)

6) Sleep Control

Activate sleep mode of the air conditioner. Use the Hr button to set the timer from 1 to 7 hours of operation. In the sleep mode, the air conditioner adjusts the temperature according to the time automatically to save power and keep the room comfortable for sleeping.

NOTE: This control key does not function during the Auto mode.

OPERATION USING CONTROL PANEL

1) Cooling Operation

- a) Be sure that the drain tank is properly placed in the unit.
- b) Install the exhaust duct properly.
- c) Plug the Power Cord to the power outlet.
- d) Turn on the unit by pressing the On/Off Button on the control panel.

For Manual Mode:

Press the Mode Button until the snowflakes and “Cool” appears on the LCD display.

- a) Press the Temperature Button \wedge or \vee until the desired room temperature appears on the LCD. The temperature ranges from 61°F-86 °F (16 °C-30 °C).
- b) Select the fan speed by pressing the Fan Speed Button.

For Auto Mode:

- a) Press the Mode Button until the “Auto” appears on the LCD display. In the Auto Mode, the factory set microprocessor controls the temperature and fan speed for

optimal comfort.

NOTE: During hot days, the unit will cool off the room most efficiently by setting the temperature at the lowest and the fan speed at the highest. Reducing the length of the exhaust duct and insulating the exhaust duct and keeping direct sunlight to a minimum will also improve the cooling efficiency.

2) Dehumidifying Operation

- a) Be sure that the drain tank is properly placed in the unit.
- b) Plug the Power Cord to the power outlet.
- c) Turn on the unit by pressing the On/Off Button on the control panel.
- d) Press the Mode Button until the bucket and dropping water and “DRY” appears on the LCD display.

NOTE: Do not use the exhaust duct when the unit is running at dehumidifying model. You must remove the exhaust duct from the unit. When the unit is running at dehumidifying mode, the fan speed cannot be adjusted.

Keep the windows and the doors closed to aid the effectiveness of the unit in removing the moisture from the room.

3) Fan Operation

- a) Plug the Power Cord to the power outlet.
- b) Turn on the unit by pressing the On/Off Button on the control panel.
- c) Press the Mode Button until “FAN” appears on the LCD display.
- d) Select the fan speed by pressing the Fan Speed Button.

NOTE: When the unit is running on fan mode, the exhaust duct is inoperative and is not required.

4) Heating Operation

- a) Plug the Power Cord to the power outlet.
- b) Turn on the unit by pressing the On/Off Button on the control panel.
- c) Press the Mode Button until “Heating Symbol” appears on the LCD display.

- d) Press the Temperature Button \wedge or \vee until the desired room temperature appears on the LCD. The temperature ranges from 61 °F-86 °F (16 °C-30 °C).
- e) Select the fan speed by pressing the Fan Speed Button.

NOTE: When the unit is running on fan mode, the exhaust duct is inoperative and is not required.

OPERATION USING REMOTE CONTROLLER

The remote controller provided with the unit may operate this portable air conditioner. The remote controller uses two - AAA batteries (provided). Install the batteries before using the remote controller.

NOTE: The information displayed on the LCD of the remote controller will only be transmitted to the air conditioner when the On/Off, Transmit, Sleep or Auto buttons (transmitting buttons) are pressed. Any changes made to the LCD display will be reversed to the previous setting if none of the transmitting buttons is pressed within 15 seconds after the changes are made.

NOTE: When the remote controller is off, the LCD only displays the current time.

REMOTE CONTROLLER

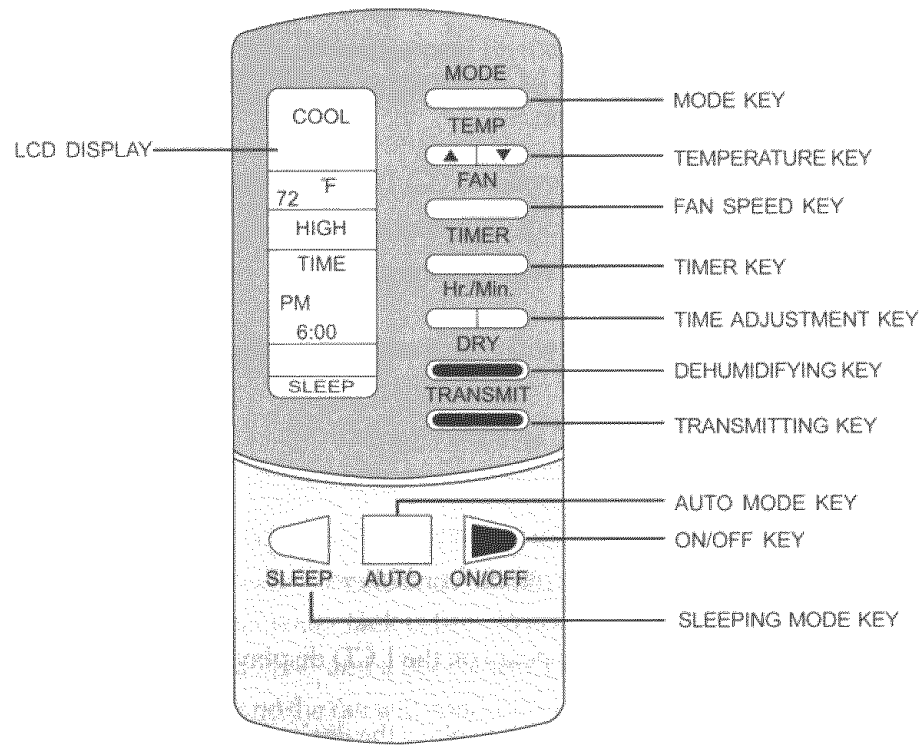

1) Set Clock

- a) Press On/Off key to turn on the remote controller
- b) Press left side (Hour) or right side (Minute) of the Time Adjustment key until the LCD displays the correct time.
- c) Press the Transmit key to set time.

2) Cooling Operation

- a) Press the On/Off key to turn on the remote controller
- b) Press the Mode key until the LCD displays "COOL"
- c) Press either \wedge or \vee key of the Temperature key until the LCD displays the desired temperature.

- d) Press the Fan Speed key until the LCD displays the desired fan speed.
- e) Press the Transmit key.

3) Heating Operation

- a) Press the On/Off key to turn on the remote controller
- b) Press the Mode key until the LCD displays “HEAT”
- c) Press either \wedge or \vee key of the Temperature key until the LCD displays the desired temperature.
- d) Press the Fan Speed key until the LCD displays the desired fan speed.
- f) Press the Transmit key.

NOTE: When pressing the Mode Key, the LCD displays “COOL”, “FAN” AND “HEAT”.

4) Dehumidifying Operation

- a) Press the On/Off key to turn on the remote controller
- b) Press Dehumidifying key. “DRY” will appear on the LCD display.
- c) Press the Transmit key.

5) Fan Operation

- a) Press the On/Off key to turn on the remote controller
- b) Press the Mode key until “FAN” appears on the LCD display.
- c) Press the Fan Speed key until the LCD displays the desired fan speed.
- d) Press the Transmit key.

6) Auto Mode

- a) Press the On/Off key to turn on the remote controller
- b) Press the Auto key. “AUTO” will appear on the LCD display.

7) Timer

- a) Press the On/Off key to turn on the remote controller
- b) Press the Timer key. “TIMER” will appear on the LCD display.
- c) Press the Time Adjustment key until the LCD displays the desired number of hours for the operation.
- d) Press the Transmit key.

8) Sleep Mode

- a) Press the On/Off key to turn on the remote controller.
- b) Press the Sleep key. “Sleep” will appear on the LCD display.
- c) Press either \wedge or \vee key of the Temperature key until the LCD displays the desired temperature.
- d) Press the Fan Speed key until the LCD displays the desired fan speed.
- e) Press Timer and Time Adjustment keys until the LCD displays the desired operation hours.
- g) Press the Transmit key.

CONDENSATE WATER DRAINAGE

1) Internal Water Tank

When operating in cooling, heating or dehumidifying mode, the condensate water will drain into the internal water tank. *Depending on the surrounding humidity*, the unit can continuously operate for 2 to 12 hours before the internal water tank is full. When the internal water tank gets full, the LCD window shows error code “E4” and a beep alarm will sound eight times for 15 seconds. The compressor stops running and the fan will continue to run in the set speed for three minutes before the entire unit automatically shuts off.

When the water tank is full, take out the entire water tank slowly and discard the water inside the tank, place it back to its original position. You will then be able to turn on the unit again.

If you want to take out the internal tank before it is full of water, please stop the unit first. Wait for 3 minutes before taking out the water tank to prevent the condensate water from discharging into the unit.

NOTE: Do not take out the water tank when the unit is running on either cooling, heating or dehumidifying mode or the alarm will sound and the compressor stops. The mode will automatically change to FAN mode and the compressor will require approximately 3 minutes to restart to the cooling, heating or dehumidifying cycle.

2) Continuous Drainage

The unit can operate on continuous drainage mode. When the unit is operating on continuous drainage mode, condensate water does not go to the internal water tank. Condensate is discharged by gravity through the drainage tubing to either an external tank (not provided) or to a condensate water pump device (Optional Item). When the unit is operating on continuous drainage mode, it can operate continuously without periodic stops to empty the water tank.

- a) Pull out the plug of the drainage spout.
- b) Push/Click down the drainage spout and make it direct downward.
- c) Hold down the drainage spout, and then connect the drainage tubing into drainage spout.
- d) Place the other end of the drainage tubing into either an external water tank or the receptor of a condensate water pump.

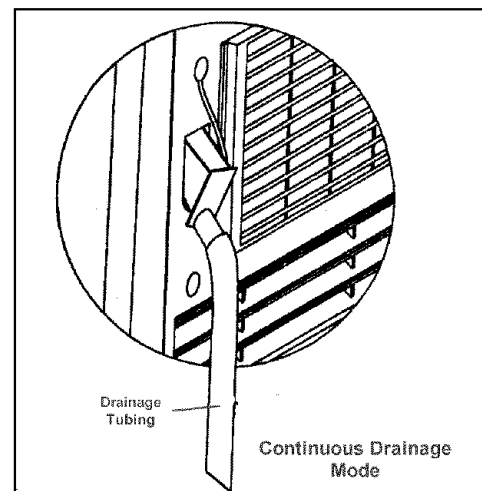
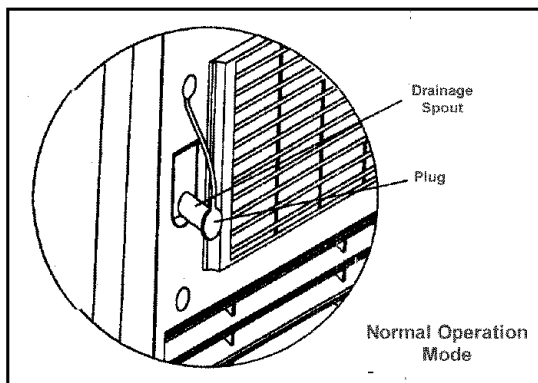
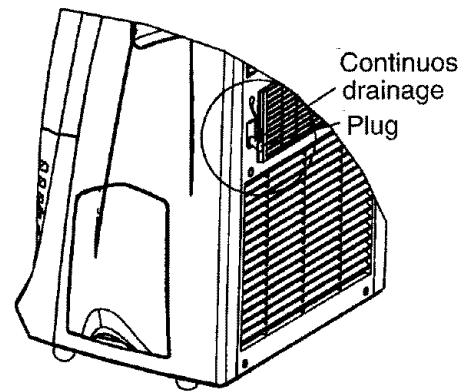

NOTE: Be very careful when using an external water tank. **The unit will not shut off automatically when an external water tank is full.** Spill water can cause substantial damages to carpet, furniture and other valuables.

Do not use lengthy drainage tubing without a condensate water pump.

MAINTENANCE

Note: Make sure power is off and the plug is pulled out of the power outlet before performing any maintenance activities.

1) Clean or replace filter

If the air filter is blocked with a lot of dust, the airflow volume will reduce. It is recommended to clean the filter once every two weeks or as needed.

- a) Push down the two tabs on the filter cover and pull outwards to remove the entire filter and cover.
- b) Carefully, take the air filter out of the filter cover.
- c) Wash the air filter by immersing it gently into warm (about 104 F) water with a neutral detergent. Rinse the filter and dry it thoroughly in a shaded place.
- d) Attach the filter to the filter cover with the attachment hooks on the inside surface of the cover.
- e) Place the bottom of the filter cover into the holes in the unit case. Push the cover back into its original position.
- f) If the filter is torn or unusable, order a new filter by calling the contact section of this manual.

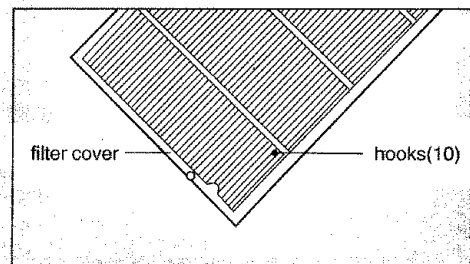
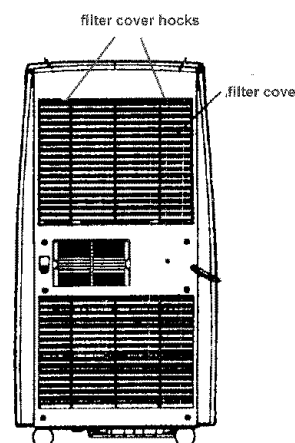

b) Case

- a. Keep the unit from being exposed directly to the sun for possible color fading.
- b. Clean the surface with a damp cloth. Dry it with a soft towel.

3) Storing the Unit for an Extended Period of Time

- a) Ensure that the water tank is empty.
- b) Unplug the unit.
- c) Remove the stopper from the internal water drain piping (Black Pipe) inside the water tank compartment and drain the water from the pipe. Reinsert the stopper back to the black drainpipe.
- d) The unit should be stored in a cool dry place.

NOTE: During normal operation do not drain water from the water black drainpipe. This water is retained for the refrigerant coil cooling purpose only.

TROUBLE SHOOTING

<i>PROBLEM</i>	<i>POSSIBLE CAUSE</i>	<i>REMEDY</i>
Unit does not operate	Unit is unplugged	Securely plug receptacle into the power outlet
	Drain tank is full	Empty water tank
	Water tank not installed correctly	Completely insert water tank
	Air exhaust is clogged	Clear exhaust hose
	Timer is on	Cancel the timer and wait for it to run automatically
Unit does not cool room	There is a heating source in the room	Turn down or off the other heating source
	Temperature setting is too high	Lower temperature setting
	Air filter is dirty	Clean or replace the air filter
	Air exhaust is not installed correctly	Check the air exhaust duct to make sure that the hot exhaust air is let out of the room freely
	Room is too big or too much ambient sunlight is reaching in	This unit provides spot cooling or cooling for a room no larger than 350 square feet with standard ceiling height
	There is frost on the evaporator	The unit will defrost automatically and return to operation afterwards
In dehumidifying mode, no cool air coming out	There is frost on the evaporator	The unit will defrost automatically and will return to operation afterwards
LCD window shows "E4"	The water tank is full	Empty the water tank
	The water tank is not installed correctly	Completely insert the water tank

Noise or vibration	Surface is not level	Place unit on a level surface and away from obstructions
Water is leaking from unit	Surface is not level	Place unit on a level surface
	Drainage plug is loose	Make sure the plug of drainage spout is securely in place and internal black drain pipe is plugged
LCD window show “E1”	Power supply is unstable	Turn off the unit and wait for ten minutes before restart. Call for technical support if the “E1” persists.

TECHNICAL SPECIFICATIONS

MODEL		KY-32H
COOLING CAPACITY		12,000 BTU/H
HEATING		6,000 BTU/H
DEHUMIDIFYING CAPACITY		1,870 OZ /Day
POWER	COOLING	1200W
	HEATING	1550W
	DEHUMIDIFYING	820W
AIR FLOW VOLUME		260 CFM
POWER SOURCE		~ 115 V 60 HZ 9.5/13 AMP HEATING/COOLING
SOUND PRESSURE LEVEL		52 db (A)
NET WEIGHT		99Lbs.
DIMENSIONS	BODY	34 x 18 x 15 Inch
	PACKAGE	45 x 21 x 19 Inch
REFRIGERANT		R22
WATER TANK VOLUME		106 OZ

NOTE:

- 1) The above cooling capacity is measured at ambient temperature of DB 86 F, WB 78 F.
- 2) Noise level is measured at the point where is 3.28 ft away from the front of the unit, in cooling mode.
- 3) Power consumption is measured when fan runs at the highest speed Specifications above are for reference only. Please see the actual data printed on the nameplate.

DISCLAIMER

ALL INFORMATION AND THE TECHNICAL SPECIFICATIONS PRESENTED IN THIS USER'S MANUAL ARE THE PRESENTATION OF THE MANUFACTURER. SOLEUS INTERNATIONAL HAS NOT CONDUCTED INDEPENDENT TEST TO THE INFORMATION AND THE SPECIFICATIONS PRESENTED HEREWITHIN.

CONTACT INFORMATION

Contact For Optional and Spare Parts
 Technical Support
 Warranty Claim
 Customer Service

Soleus International Inc.
9451 Telstar Ave.
El Monte, CA 91731 USA
(888)8-SOLEUS
www.soleusair.com

WARRANTY

ONE YEAR LIMITED WARRANTY

Soleus International Inc. warrants the accompanying Soleus Air KY-32H Mobile Air Conditioner to be free of defects in material and workmanship for the applications specified in its operation instruction for a period of ONE (1) year from the date of original retail purchase in the United States or Canada.

If the air conditioner exhibits a defect in normal use, Soleus International Inc. will, at its option, either repair or replace it, free of charge within a reasonable time after the air conditioner is returned during the warranty period.

As a condition to any warranty service obligation, the consumer must present this Warranty Certificate along with a copy of the original purchase invoice.

THIS WARRANTY DOES NOT COVER:

- 1) Damage, accidental or other wise, to the air conditioner while in the possession of a consumer not caused by a defect in material or workmanship;
- 2) Damage caused by consumer misuse, tampering, or failure to follow the care and special handling provisions in the instructions.
- 3) Damage to the finish of the case, or other appearance parts caused by wear.
- 4) Filter.
- 5) Damage caused by repairs or alterations of the air conditioner by anyone other than authorized by Soleus International Inc..
- 6) Freight and Insurance cost for the warranty service.

ALL WARRANTIES, INCLUDING ANY IMPLIED WARRANTY OF MERCHANTABILITY ARE LIMITED TO ONE-YEAR DURATION OF THIS EXPRESS LIMITED WARRANTY. SOLEUS INTERNATIONAL INC. DISCLAIMS ANY LIABILITY FOR CONSEQUENTIAL OR INCIDENTAL DAMAGES AND IN NO EVENT SHALL SOLEUS INTERNATIONAL INC.'S LIABILITY EXCEED THE RETAIL VALUE OF THE AIR CONDITIONER FOR BREACH OF ANY WRITTEN OR IMPLIED WARRANTY WITH RESPECT TO THIS AIR CONDITIONER