

PRO-FORM[®] XP 100 U

Model No. 831.21641.0

Serial No. _____

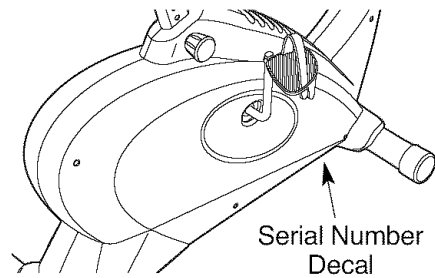

- Assembly
- Operation
- Maintenance
- Part List and Drawing

CAUTION

Read all precautions and instructions in this manual before using this equipment. Keep this manual for future reference.

BIKE EXERCISER User's Manual

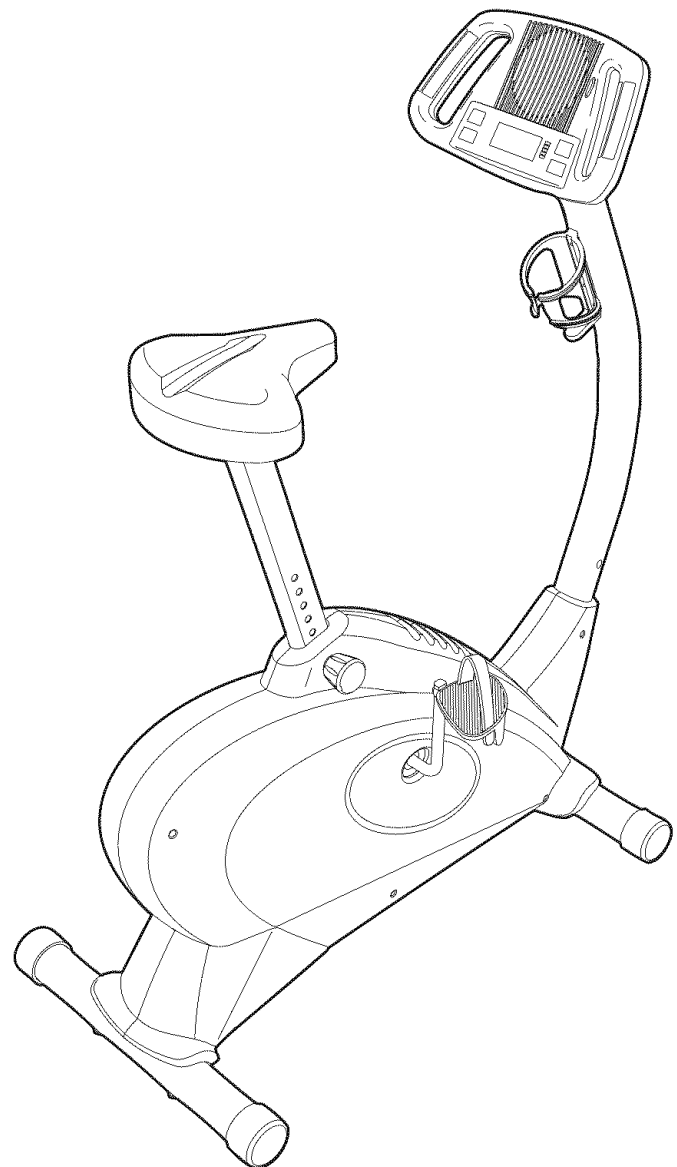

Sears, Roebuck and Co., Hoffman Estates, IL 60179

TABLE OF CONTENTS

IMPORTANT PRECAUTIONS	2
BEFORE YOU BEGIN	3
ASSEMBLY	4
HOW TO OPERATE THE EXERCISE CYCLE	8
MAINTENANCE AND TROUBLESHOOTING	16
CONDITIONING GUIDELINES	17
PART LIST	18
EXPLODED DRAWING	19
HOW TO ORDER REPLACEMENT PARTS	Back Cover
90 DAY FULL WARRANTY	Back Cover

IMPORTANT PRECAUTIONS

⚠ WARNING: To reduce the risk of serious injury, read the following important precautions before using the exercise cycle.

1. Read all instructions in this manual and all warnings on the exercise cycle before using the exercise cycle. Use the exercise cycle only as described in this manual.
2. It is the responsibility of the owner to ensure that all users of the exercise cycle are adequately informed of all precautions.
3. The exercise cycle is intended for home use only. Do not use the exercise cycle in a commercial, rental, or institutional setting.
4. Keep the exercise cycle indoors, away from moisture and dust. Place the exercise cycle on a level surface, with a mat beneath it to protect the floor. Make sure that there is enough clearance around the exercise cycle to mount, dismount, and use it.
5. Inspect and properly tighten all parts regularly. Replace any worn parts immediately.
6. Keep children under the age of 12 and pets away from the exercise cycle at all times.
7. The exercise cycle should not be used by persons weighing more than 250 pounds.
8. Wear appropriate clothes while exercising; do not wear loose clothes that could become caught on the exercise cycle. Always wear athletic shoes for foot protection.
9. The pulse sensor is not a medical device. Various factors, including the user's movement, may affect the accuracy of heart rate readings. The pulse sensor is intended only as an exercise aid in determining heart rate trends in general.
10. Always keep your back straight while using the exercise cycle; do not arch your back.
11. If you feel pain or dizziness while exercising, stop immediately and cool down.
12. The exercise cycle does not have a freewheel; the pedals will continue to move until the fly-wheel stops.
13. The warning decal shown on page 3 has been placed on the exercise cycle. If the decal is missing or illegible, call toll-free 1-888-533-1333 and request a free replacement decal. Apply the decal in the location shown.

⚠ WARNING: Before beginning this or any exercise program, consult your physician. This is especially important for persons over the age of 35 or persons with pre-existing health problems. Read all instructions before using. Sears assumes no responsibility for personal injury or property damage sustained by or through the use of this product.

BEFORE YOU BEGIN

Congratulations for selecting the new PROFORM® XP 100 U exercise cycle. Cycling is one of the most effective exercises for increasing cardiovascular fitness, building endurance, and toning the entire body. The XP 100 U exercise cycle offers a selection of features designed to let you enjoy this healthful exercise in the convenience and privacy of your home.

For your benefit, read this manual carefully before you use the exercise cycle. If you have questions

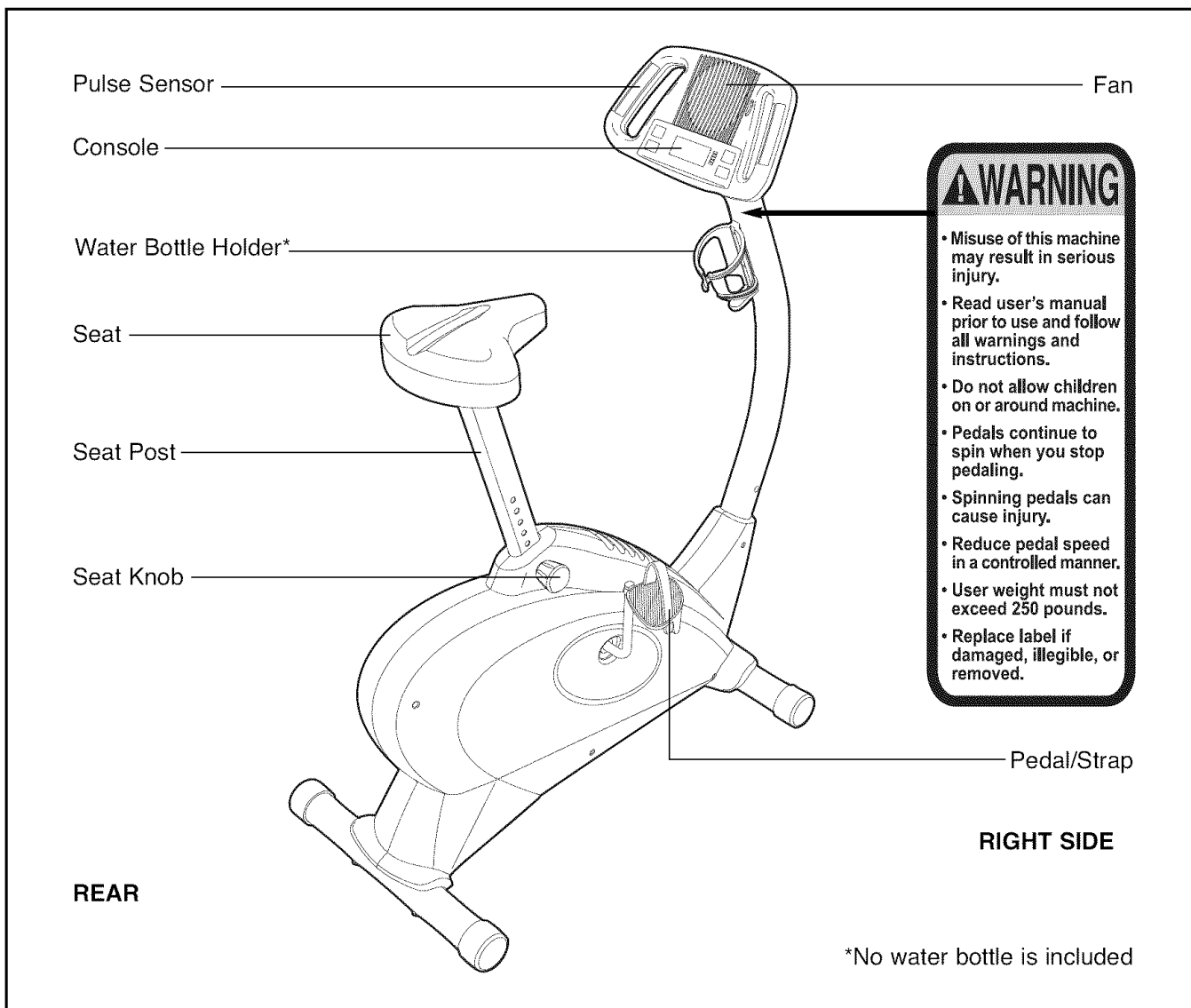

after reading this manual, call 1-800-4-MY-HOME® (1-800-469-4663). To help us assist you, please note the product model number and serial number before calling. The model number is 831.21641.0. The serial number can be found on a decal attached to the exercise cycle (see the front cover of this manual for the location of the decal).

Before reading further, please familiarize yourself with the parts that are labeled in the drawing below.



ASSEMBLY

Assembly requires two persons. Place all parts of the exercise cycle in a cleared area and remove the packing materials. Do not dispose of the packing materials until assembly is completed.

Assembly requires the included tools and your own adjustable wrench  **and Phillips screwdriver** .

Use the part drawings below to identify the small parts used in assembly. The number in parenthesis below each drawing refers to the key number of the part, from the PART LIST on page 18. The second number refers to the quantity needed for assembly. **Note: Some small parts may have been pre-attached for shipping. If a part is not in the parts bag, check to see if it has been pre-attached. If a part is missing, call toll-free 1-888-533-1333.**

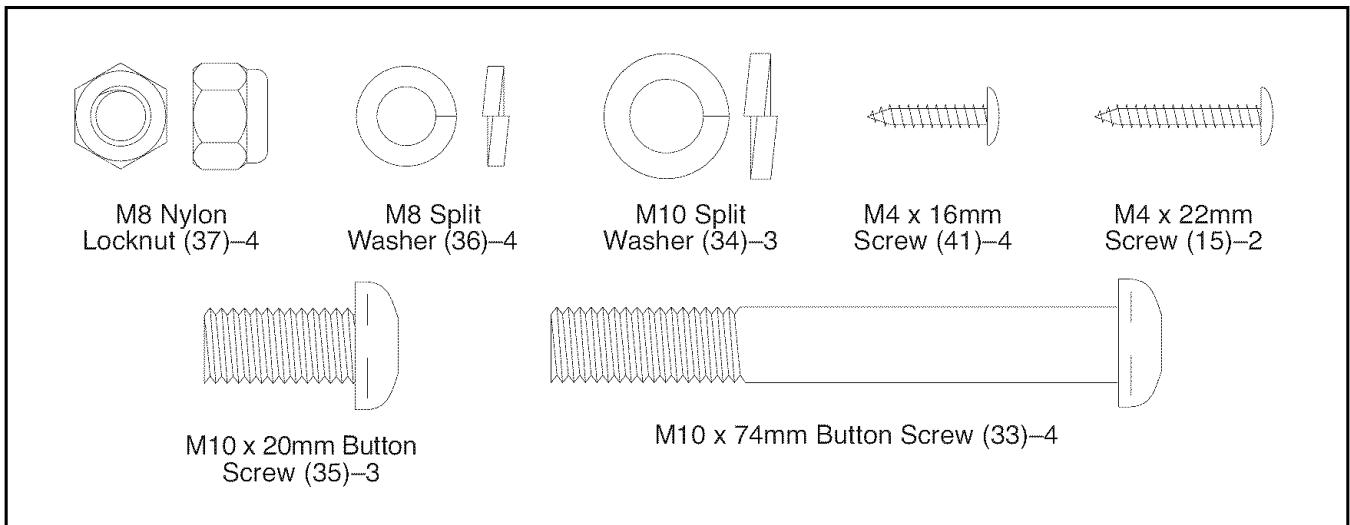

1. Identify the Front Stabilizer (2), which is narrower than the Rear Stabilizer (not shown). While another person lifts the front of the Frame (1), attach the Front Stabilizer to the Frame with two M10 x 74mm Button Screws (33).

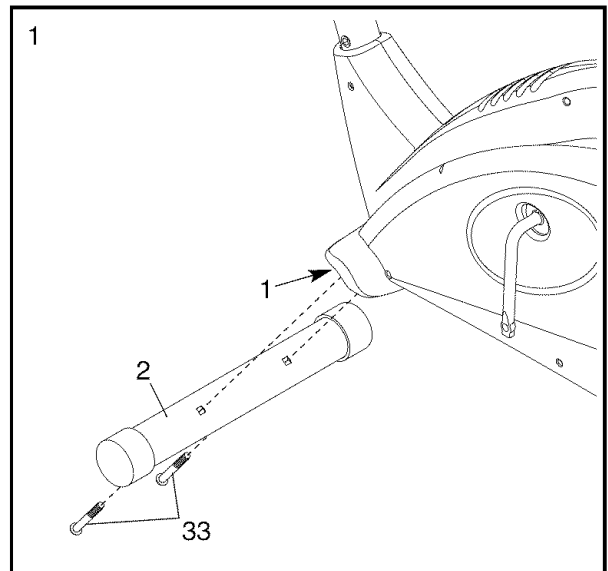

2. While another person lifts the rear of the Frame (1), attach the Rear Stabilizer (14) to the Frame with two M10 x 74mm Button Screws (33).

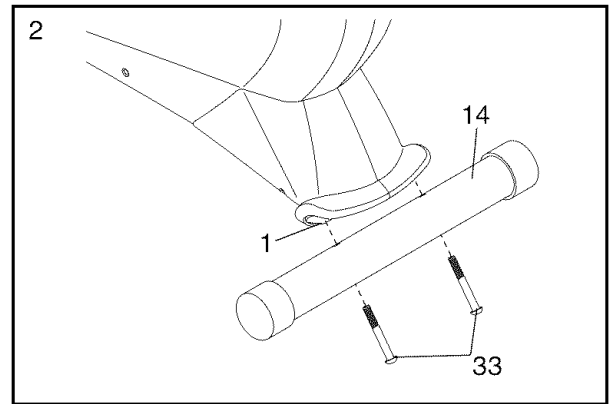

3. While another person holds the Upright (3) near the Frame (1), connect the Upper Wire Harness (32) to the Lower Wire Harness (31).

Gently pull the upper end of the Upper Wire Harness (32) to remove the slack, and slide the Upright (3) onto the Frame (1). **Be careful to avoid pinching the Wire Harnesses.** Attach the Upright with three M10 x 20mm Button Screws (35) and three M10 Split Washers (34).

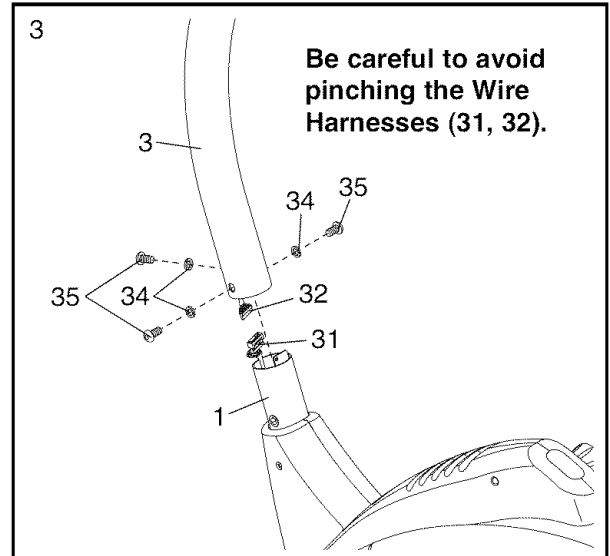

4. Attach the Water Bottle Holder (29) to the Upright (3) with two M4 x 22mm Screws (15).

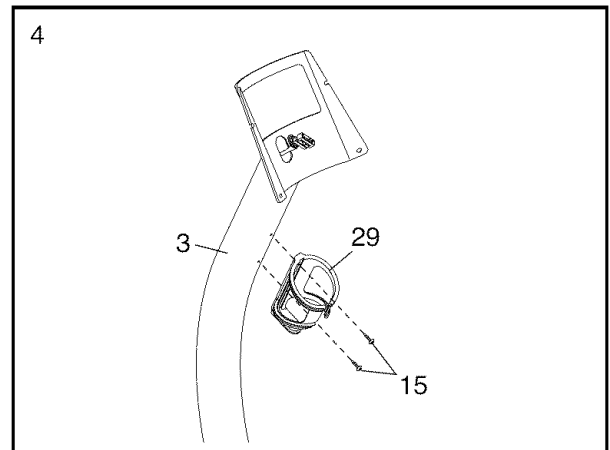

5. The Console (6) requires four “D” batteries (not included); alkaline batteries are recommended. Press the tab on the battery cover and remove the battery cover. Insert four batteries into the console; **make sure that the batteries are oriented as shown.** Then, reattach the battery cover.

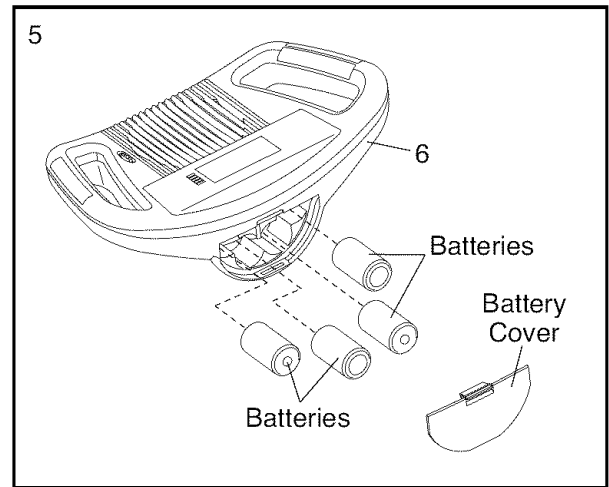

6. While another person holds the Console (6) near the Upright (3), connect the console wire harness to the Upper Wire Harness (32).

Insert the excess Wire Harness (32) downward into the Upright (3). Attach the Console (6) to the Upright with four M4 x 16mm Screws (41). **Make sure that the Wire Harness is not pinched.**

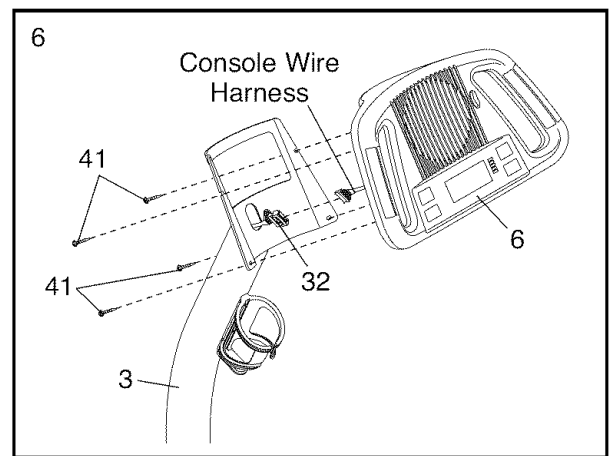

7. Attach the Seat (12) to the Seat Post (5) with four M8 Nylon Locknuts (37) and four M8 Split Washers (36). **Note: The Nylon Locknuts and Split Washers may be preattached to the Seat.**

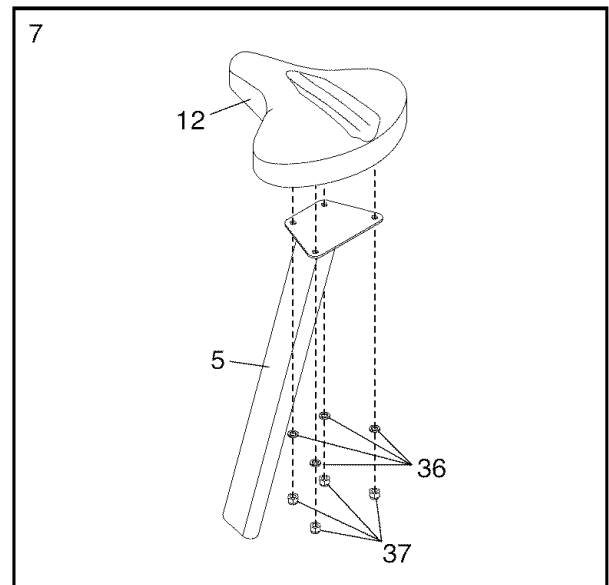

8. Remove the packing tube from the Frame (1), and discard the packing tube.

Turn the Seat Knob (11) counterclockwise two or three turns to loosen it (if the Seat Knob is not loosened enough, it may scratch the Seat Post [5]). Next, pull the Seat Knob, insert the Seat Post into the Frame (1), and then release the Seat Knob. **Move the Seat Post up and down slightly until the pin on the Seat Knob snaps into one of the holes in the Seat Post.** Then, turn the Seat Knob clockwise until it is tight.

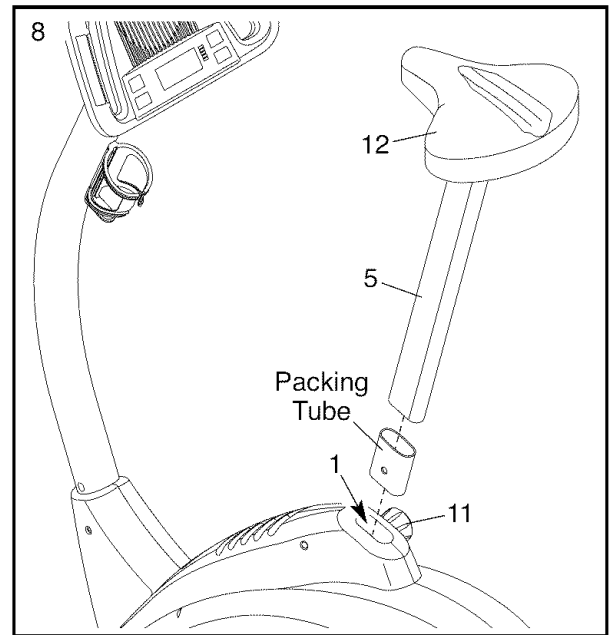

9. Identify the Left Pedal (24), which is marked with an "L." Using an adjustable wrench, **firmly tighten** the Left Pedal *counterclockwise* into the left arm of the Crank (13). Tighten the Right Pedal (not shown) *clockwise* into the right arm of the Crank. **Important: Tighten both Pedals as firmly as possible. After using the exercise cycle for one week, retighten the Pedals. For best performance, keep the Pedals tightened.**

Adjust the left Pedal Strap (25) to the desired position, and press the end of the Pedal Strap onto the tab on the side of the Left Pedal (24). Adjust the right Pedal Strap (not shown) in the same way.

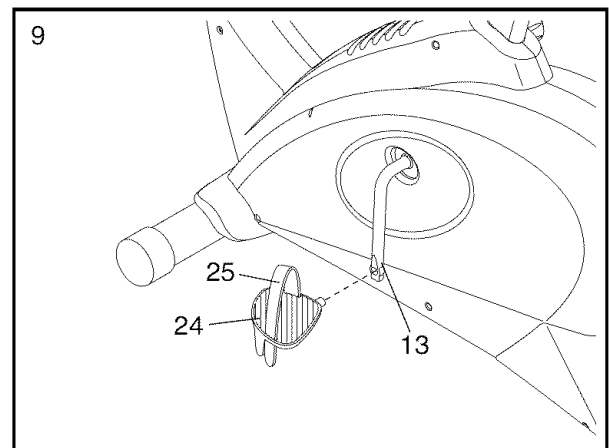

10. **Make sure that all parts are properly tightened before you use the exercise cycle.** Note: After assembly is completed, some extra parts may be left over. Place a mat beneath the exercise cycle to protect the floor.

HOW TO OPERATE THE EXERCISE CYCLE

HOW TO ADJUST THE SEAT

For effective exercise, the seat should be at the proper height. As you pedal, there should be a slight bend in your knees when the pedals are in the lowest position. To adjust the height of the seat, first turn the seat knob counter-clockwise two or three turns to loosen it (if the knob is not loosened enough, it may scratch the seat post). Next, pull the knob, slide the seat post to the desired height, and then release the knob. **Move the seat post up and down slightly until the pin on the knob snaps into one of the holes in the seat post.** Then, turn the knob clockwise until it is tight.

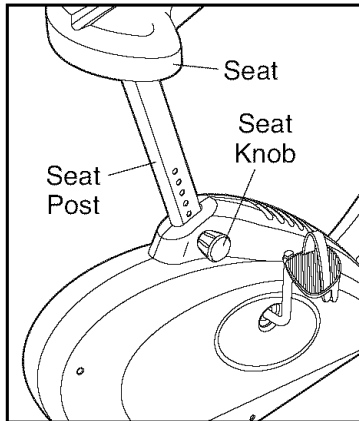

HOW TO ADJUST THE PEDAL STRAPS

To adjust the pedal straps, first pull the ends of the pedal straps off the tabs on the pedals. Adjust the pedal straps to the desired position, and then press the ends of the pedal straps back onto the tabs.

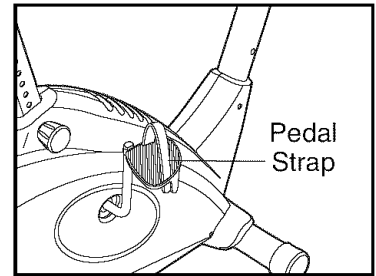

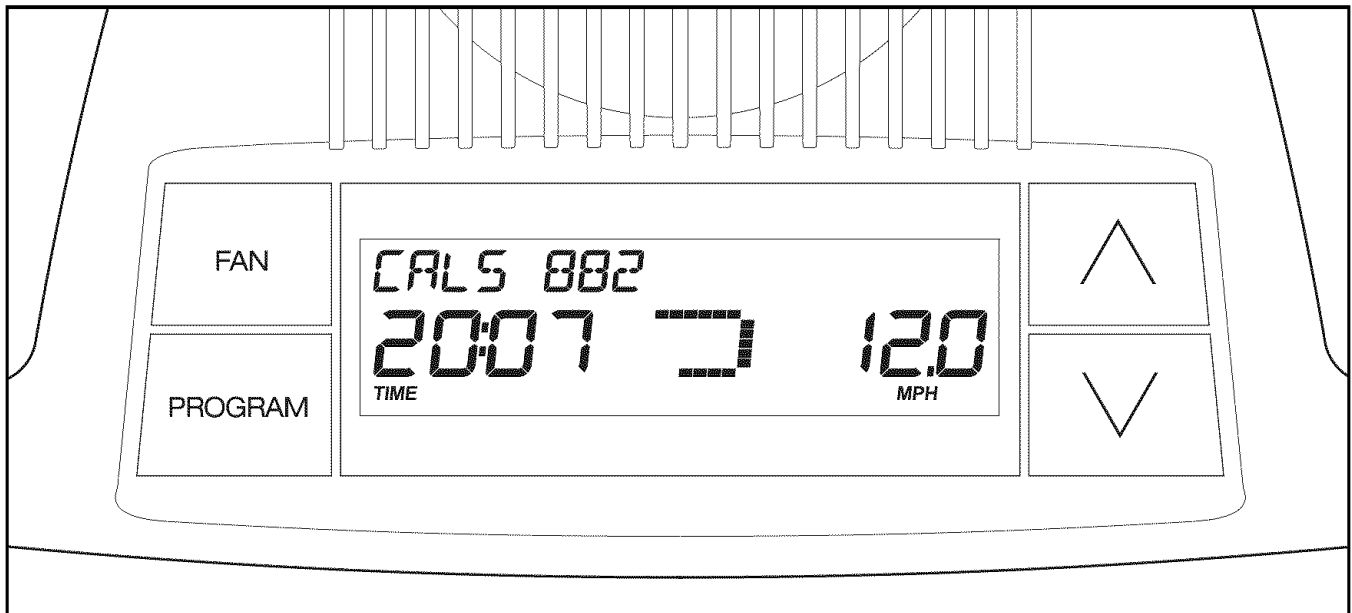

FEATURES OF THE CONSOLE

The advanced console offers an array of features designed to make your workouts more effective and enjoyable.

When you select the manual mode of the console, you can change the resistance of the pedals with the touch of a button. As you exercise, the console will display continuous exercise feedback. You can even measure your heart rate using the handgrip pulse sensor.

The console offers two trainer programs that automatically change the resistance of the pedals and prompt you to increase or decrease your pace while guiding you through an effective workout.

The console also features three interactive cross training programs designed to help you to burn calories and enhance your cardiovascular system while toning and strengthening your muscles. The cross training programs automatically control the resistance of the pedals and prompt you to perform a variety of strength

exercises during your workout. Choose an upper body, lower body, or whole body cross training program for a focused workout. Note: The strength exercises require the use of dumbbells and an inflatable exercise ball (not included). **To purchase dumbbells or an exercise ball, call toll-free 1-888-533-1333.**

You can also use two calorie goal programs designed to help you burn 300 calories in 30- or 45-minute workouts. The calorie goal programs automatically control the resistance of the pedals and prompt you to increase or decrease your pace while counting the calories you burn.

To use the manual mode of the console, follow the steps beginning on page 10. **To use a trainer program**, see page 12. **To use a cross training program**, see page 13. **To use a calorie goal program**, see page 15.

Note: If there is a sheet of clear plastic on the face of the console, remove the plastic.

HOW TO USE THE MANUAL MODE

1 Press any button or begin pedaling to turn on the console.

A moment after you turn on the console, the display will light.

2 Select the manual mode.

Each time you turn on the console, the manual mode will be selected automatically. If you have selected a program, reselect the manual mode by pressing the Programs button repeatedly until the words MANUAL MODE appear in the top of the display.

3 Begin pedaling and change the resistance of the pedals as desired.

As you pedal, change the resistance of the pedals by pressing the Increase and Decrease buttons repeatedly. There are ten resistance levels. Note: After you press the buttons, it will take a moment for the pedals to reach the selected resistance level.

4 Follow your progress with the display.

The left side of the display—The left side of the display will show the elapsed time. Note: When a program is selected, the display will show the time remaining in the program instead of the elapsed time.

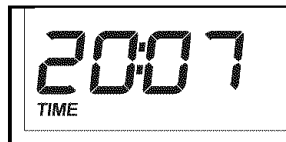

The left side of the display will also show your heart rate when you use the handgrip pulse sensor (see step 5 on page 11).

When a program is selected, the left side of the display will also show the approximate number of calories you have burned.

The center of the display—When you select the manual mode, the center of the display will show a track that represents

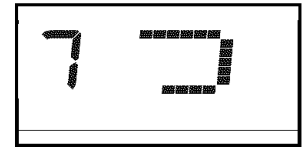

1/4 mile. As you exercise, indicators will appear in succession around the track until the entire track appears. The track will then disappear and the indicators will again begin to appear in succession.

The center of the display will also show the resistance setting of the pedals for a few seconds each time the resistance setting changes.

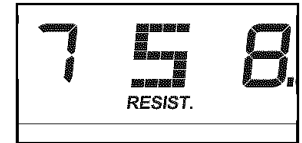

The right side of the display—The right side of the display will show the distance (in miles or kilometers) you have pedaled and your pedaling pace, in miles or kilometers per hour.



The top of the display—When you select the manual mode, the top of the display will show the approximate number of calories you have burned.

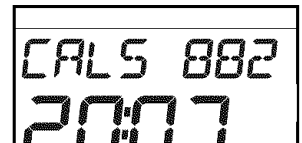

Note: The console can display speed and distance in either miles or kilometers. The letters MPH or Km/H will

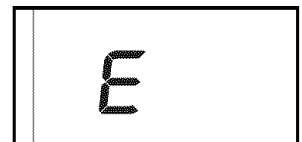

appear in the display to indicate the selected unit of measurement. To change the unit of measurement, first hold down the Program button for several seconds. An E (for English) or an M (for metric) will appear in the display. Press the Increase button to change the unit of measurement. When the desired unit of measurement is selected, press the Program button again. Note: When you replace the batteries, it may be necessary to reselect the unit of measurement.

5 Measure your heart rate if desired.

If there are sheets of clear plastic on the metal contacts on the handgrip pulse sensor, remove the plastic.

To measure your heart rate, hold the handgrip pulse sensor with your palms resting against the metal contacts. **Avoid moving your hands or gripping the contacts too tightly.**

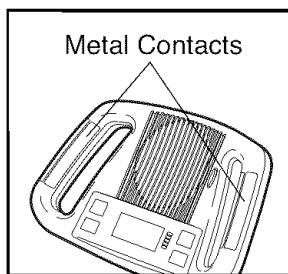

When your pulse is detected, a heart-shaped symbol will flash in the left side of the display each time your heart

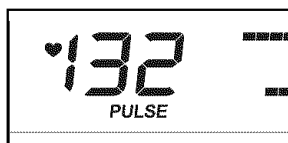

beats, one or two dashes will appear, and then your heart rate will be shown. For the most accurate heart rate reading, hold the contacts for at least 15 seconds. Note: If you continue to hold the handgrip pulse sensor, the display will show your heart rate for up to 30 seconds.

If your heart rate is not shown, make sure that your hands are positioned as described. Be careful not to move your hands excessively or to squeeze the metal contacts too tightly. For optimal performance, clean the metal contacts using a soft cloth; **never use alcohol, abrasives, or chemicals to clean the contacts.**

6 Turn on the fan if desired.

To turn on the fan at high speed, press the Fan button. To turn on the fan at low speed, press the button a second time. To turn off the fan, press the button a third time. Note: If the pedals do not move for a few minutes, the fan will automatically turn off to conserve the batteries.

Pivot the thumb tab on the right side of the fan to adjust the fan angle.

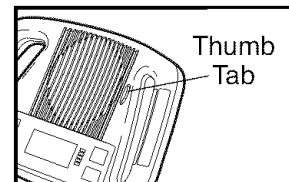

7 When you are finished exercising, the console will turn off automatically.

If the pedals do not move for several seconds, a tone will sound and the console will pause.

If the pedals do not move for about five minutes and the buttons are not pressed, the console will turn off and the display will be reset.

HOW TO USE A TRAINER PROGRAM

1 Press any button or begin pedaling to turn on the console.

A moment after you turn on the console, the display will light.

2 Select a trainer program.

Press the Program button repeatedly until the words TRAINER 1 or TRAINER 2 appear in the display. When you select a trainer program, the program time will appear in the display and a profile of the resistance settings for the program will scroll across the center of the display.

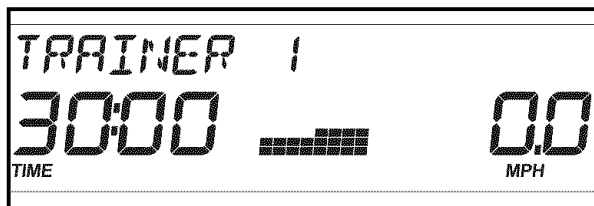

3 Begin pedaling to start the program.

Each program is divided into 30 one-minute segments. One resistance setting and one target pace (speed) setting are programmed for each segment. Note: The same resistance setting and/or target pace setting may be programmed for two or more consecutive segments.

The resistance setting for the first segment will be shown in the flashing Current Segment column of the profile. The resistance settings for the next several segments will be shown in the columns to the right. The target pace setting will appear in the top of the display.

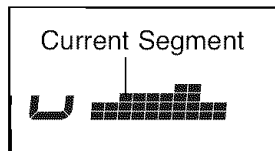

When only three seconds remain in the first segment of the program, both the Current Segment column and the column to the right will flash and a series of tones will sound. If the resistance and/or target pace is about to change, the resistance setting and/or target pace setting will appear in the display to alert you.

When the first segment is completed, *all resistance settings will move one column to the left.* The resistance setting for the second segment will then be shown in the flashing Current Segment column and the resistance of the pedals will automatically adjust to the setting for the sec-

ond segment. Note: If all the indicators in the Current Segment column are lit, *the resistance settings may move downward* so that only the highest indicators appear.

As you exercise, you will be prompted to keep your pedaling pace near the target pace setting for the current segment. When the words PEDAL FASTER appear in the display, increase your pace. When the words PEDAL SLOWER appear in the display, decrease your pace. When the words PEDALING IN RANGE appear, maintain your current pace.

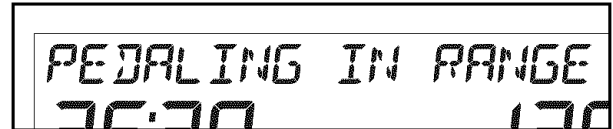

Important: The target pace settings are intended only to provide motivation. Your actual pace may be slower than the target pace settings. Make sure to exercise at a pace that is comfortable for you.

You can manually override the resistance setting, if desired, by pressing the Increase and Decrease buttons. Every few times you press a button, an additional indicator will appear or disappear in the Current Segment column. **However, when the current segment ends, the pedals will automatically adjust to the resistance setting for the next segment.**

To stop the program at any time, stop pedaling. The time will begin to flash in the display. To restart the program, simply resume pedaling.

When the last segment of the program ends, the words PROGRAM DONE will appear in the display.

4 Follow your progress with the display.

See step 4 on page 10.

5 Measure your heart rate if desired.

See step 5 on page 11.

6 Turn on the fan if desired.

See step 6 on page 11.

7 When you are finished exercising, the console will turn off automatically.

See step 7 on page 11.

HOW TO USE A CROSS TRAINING PROGRAM

- 1 Press any button or begin pedaling to turn on the console.**

A moment after you turn on the console, the display will light.

- 2 Select a cross training program.**

Press the Program button repeatedly until the name of the desired cross training program appears in the display. When you select a cross training program, the program time will appear in the display and a profile of the resistance settings for the program will scroll across the center of the display.

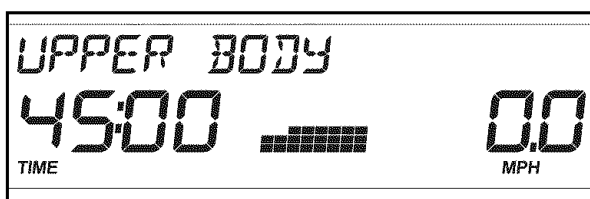

- 3 Begin pedaling to start the program.**

Each program is divided into 30 or 45 one-minute segments. One resistance setting and one target pace (speed) setting are programmed for most segments. (Note: The same resistance and/or target pace setting may be programmed for two or more consecutive segments.) During other segments, the console will prompt you to perform strength exercises.

The displays for the cross training programs work in the same way as the displays for the trainer programs (see step 3 on page 12).

As you exercise, you will be prompted to keep your pedaling pace near the target pace setting for the current segment. When the words PEDAL FASTER appear in the display, increase your pace. When the words PEDAL SLOWER appear in the display, decrease your pace. When the words PEDALING IN RANGE appear, maintain your current pace.

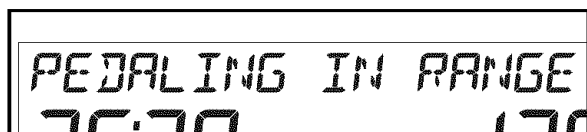

Important: The target pace settings are intended only to provide motivation. Your actual pace may be slower than the target pace settings. Make sure to exercise at a pace that is comfortable for you.

To stop the program at any time, stop pedaling. The time will begin to flash in the display. To restart the program, simply resume pedaling.

- 4 Perform the first strength exercise when prompted.**

When the first strength exercise segment begins, the name of the first strength exercise will appear in the display for a few seconds. The time will pause and flash in the display. Next, the display will show the recommended number of repetitions for the first strength exercise.

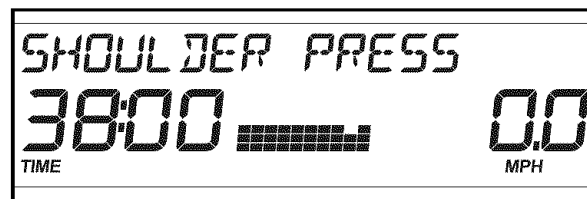

Step off the exercise cycle and prepare to begin the first strength exercise. Every few seconds, the console will sound a tone; when a tone sounds, perform one repetition of the exercise. Exercise with a slow, steady motion; do not perform more than one repetition each time a tone sounds. The display will count down the repetitions as you perform them.



Note: Refer to the accompanying exercise chart to see the correct form for each exercise. When performing lunges, alternate legs with each repetition. When performing dumbbell rows, perform half the repetitions with your right arm and half the repetitions with your left arm. The strength exercises require the use of dumbbells and an inflatable exercise ball (not included). **To purchase dumbbells or an exercise ball, call toll-free 1-888-533-1333.**

5 Continue the cross training program.

When you have performed the recommended number of repetitions, the words START PEDALING will appear in the display. To continue the cross training program, step onto the exercise cycle and start pedaling. The pedals will automatically adjust to the resistance setting for the next segment.



The program will continue in this way until the last segment ends. Then, the words PROGRAM DONE will appear in the display.

6 Follow your progress with the display.

See step 4 on page 10.

7 Measure your heart rate if desired.

See step 5 on page 11.

8 Turn on the fan if desired.

See step 6 on page 11.

9 When you are finished exercising, the console will turn off automatically.

See step 7 on page 11.

HOW TO USE A CALORIE GOAL PROGRAM

1 Press any button or begin pedaling to turn on the console.

A moment after you turn on the console, the display will light.

2 Select one of the calorie goal programs.

Press the Program button repeatedly until the name of the desired calorie goal program appears in the display. When you select a calorie goal program, the program time will appear in the display and a profile of the resistance settings for the program will scroll across the center of the display.

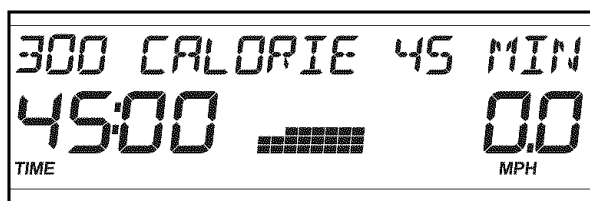

3 Begin pedaling to start the program.

Each program is divided into 30 or 45 one-minute segments. One resistance setting and one target pace (speed) setting are programmed for each segment. Note: The same resistance setting and/or target pace setting may be programmed for two or more consecutive segments. The display for a calorie goal program work in the same way as the display for the trainer programs (see step 3 on page 12).

As you exercise, you will be prompted to keep your pace near the target pace setting for the current segment. When the words PEDAL FASTER appear in the display, increase your pace. When the words PEDAL SLOWER appear in the display, decrease your pace. When the words PEDALING IN RANGE appear, maintain your current pace.

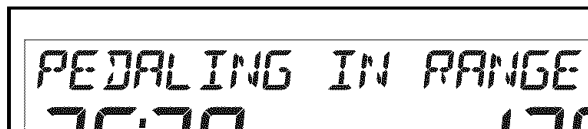

Important: The target pace settings are intended only to provide motivation. Your actual pace may be slower than the target pace settings. Make sure to exercise at a pace that is comfortable for you. Note: If you manually override the resistance settings of a calorie goal program, you might not reach your calorie goal.

To stop the program at any time, stop pedaling. The time will begin to flash in the display. To restart the program, simply resume pedaling.

When the last segment of the program ends, the words PROGRAM DONE will appear in the display.

4 Follow your progress with the display.

See step 4 on page 10.

5 Measure your heart rate if desired.

See step 5 on page 11.

6 Turn on the fan if desired.

See step 6 on page 11.

7 When you are finished exercising, the console will turn off automatically.

See step 7 on page 11.

MAINTENANCE AND TROUBLESHOOTING

Inspect and properly tighten all parts of the exercise cycle regularly. Replace any worn parts immediately.

To clean the exercise cycle, use a damp cloth and a small amount of mild soap—**never use alcohol, abrasives, or chemicals to clean the exercise cycle.**

Important: To avoid damage to the console, keep liquids away from the console and keep the console out of direct sunlight.

BATTERY REPLACEMENT

If the console display becomes dim, the batteries should be replaced; most console problems are the result of low batteries. To replace the batteries, see assembly step 5 on page 5.

PULSE SENSOR TROUBLESHOOTING

For optimal performance of the pulse sensor, keep the metal contacts clean. Clean the contacts with a soft cloth—**never use alcohol, abrasives, or chemicals to clean the metal contacts.**

Avoid moving your hands or squeezing the metal contacts too tightly while using the pulse sensor; doing so may interfere with heart rate readings. For the most accurate heart rate reading, hold the metal contacts for about 15 seconds.

CONDITIONING GUIDELINES

The following guidelines will help you to plan your exercise program. Remember that proper nutrition and adequate rest are essential for successful results.



WARNING:

Before beginning this or any exercise program, consult your physician. This is especially important for persons over the age of 35 or persons with pre-existing health problems.

The pulse sensor is not a medical device. Various factors may affect the accuracy of heart rate readings. The pulse sensor is intended only as an exercise aid in determining heart rate trends in general.

EXERCISE INTENSITY

Whether your goal is to burn fat or to strengthen your cardiovascular system, the key to achieving the desired results is to exercise with the proper intensity. The proper intensity level can be found by using your heart rate as a guide. The chart below shows recommended heart rates for fat burning, maximum fat burning, and cardiovascular (aerobic) exercise.

165	155	145	140	130	125	115	
145	138	130	125	118	110	103	
125	120	115	110	105	95	90	
<hr/>							
20	30	40	50	60	70	80	

To find the proper heart rate for you, first find your age at the bottom of the chart (ages are rounded off to the nearest ten years). Next, find the three numbers above your age. The three numbers are your “training zone.” The lowest number is the recommended heart rate for fat burning; the middle number is the recommended heart rate for maximum fat burning; the highest number is the recommended heart rate for aerobic exercise.

Fat Burning

To burn fat effectively, you must exercise at a relatively low intensity level for a sustained period of time.

During the first few minutes of exercise, your body uses easily accessible *carbohydrate* calories for energy. Only after the first few minutes of exercise does your body begin to use stored *fat* calories for energy. If your goal is to burn fat, adjust the intensity of your exercise until your heart rate is near the lowest number in your training zone as you exercise. For maximum fat burning, adjust the intensity of your exercise until your heart rate is near the middle number in your training zone as you exercise.

Aerobic Exercise

If your goal is to strengthen your cardiovascular system, your exercise must be “aerobic.” Aerobic exercise is activity that requires large amounts of oxygen for prolonged periods of time. This increases the demand on the heart to pump blood to the muscles, and on the lungs to oxygenate the blood. For aerobic exercise, adjust the intensity of your exercise until your heart rate is near the highest number in your training zone.

WORKOUT GUIDELINES

Each workout should include the following three parts:

A warm-up, consisting of 5 to 10 minutes of stretching and light exercise. A proper warm-up increases your body temperature, heart rate, and circulation in preparation for exercise.

Training zone exercise, consisting of 20 to 30 minutes of exercising with your heart rate in your training zone. Note: During the first few weeks of your exercise program, do not keep your heart rate in your training zone for longer than 20 minutes.

A cool-down, with 5 to 10 minutes of stretching. This will increase the flexibility of your muscles and will help to prevent post-exercise problems.

EXERCISE FREQUENCY

To maintain or improve your condition, plan three workouts each week, with at least one day of rest between workouts. After a few months of regular exercise, you may complete up to five workouts each week, if desired. Remember, the key to success is make exercise a regular and enjoyable part of your everyday life.

PART LIST—Model No. 831.21641.0

R1106A

Key No.	Qty.	Description	Key No.	Qty.	Description
1	1	Frame	23	1	Belt
2	1	Front Stabilizer	24	1	Left Pedal
3	1	Upright	25	2	Pedal Strap
4	4	Endcap	26	1	Right Pedal
5	1	Seat Post	27	1	Crank Bearing Set
6	1	Console	28	1	Idler
7	1	Eddy Mechanism	29	1	Water Bottle Holder
8	1	Resistance Motor	30	1	Idler Pulley
9	1	Crank Nut	31	1	Lower Wire Harness
10	1	Pillow Block	32	1	Upper Wire Harness
11	1	Adjustment Knob	33	4	M10 x 74mm Button Screw
12	1	Seat	34	3	M10 Split Washer
13	1	Pulley/Crank	35	3	M10 x 20mm Button Screw
14	1	Rear Stabilizer	36	4	M8 Split Washer
15	2	M4 x 22mm Screw	37	4	M8 Nylon Locknut
16	1	Magnet	38	4	M6 Nylon Locknut
17	1	Left Side Shield	39	4	M4 x 25mm Screw
18	1	Right Side Shield	40	1	M4 x 5mm Screw
19	1	Eddy Axle Assembly	41	14	M4 x 16mm Screw
20	1	Seat Post Bushing	#	1	User's Manual
21	1	Reed Switch/Wire	#	1	Hex Key
22	1	Clamp			

Note: “#” indicates a non-illustrated part. Specifications are subject to change without notice. **If a part is missing, call toll-free 1-888-533-1333.** See the back cover of this manual for information about ordering replacement parts.

EXPLODED DRAWING—Model No. 831.21641.0

R1106A

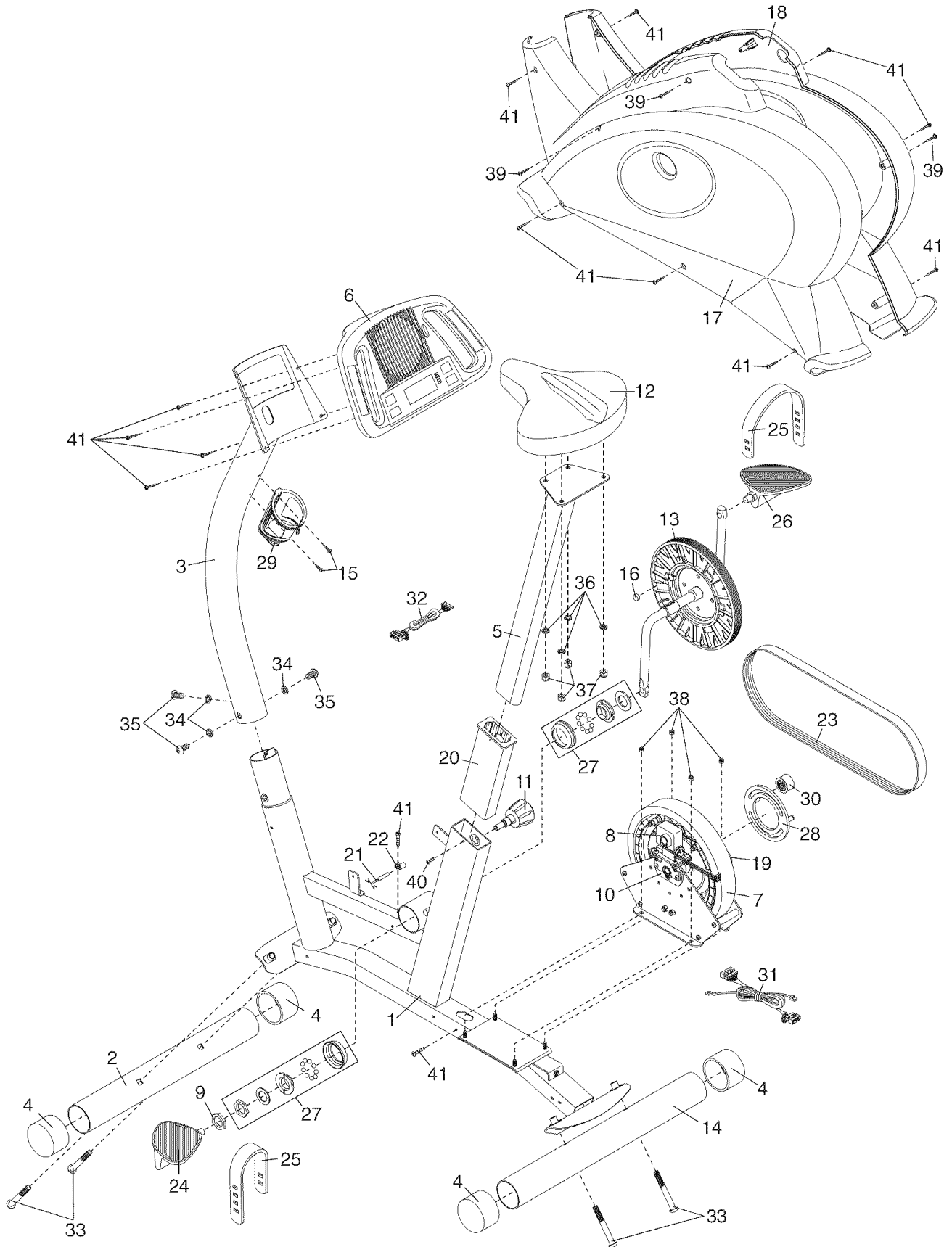

Get it fixed, at your home or ours!

Your Home

For repair—**in your home**—of **all** major brand appliances, lawn and garden equipment, or heating and cooling systems, **no matter who made it, no matter who sold it!**

For the replacement parts, accessories, and user's manuals that you need to do-it-yourself.

For Sears professional installation of home appliances and items like garage door openers and water heaters.

1-800-4-MY-HOME® (1-800-469-4663)

Call anytime, day or night (U.S.A. and Canada)

www.sears.com

www.sears.ca

Our Home

For repair of carry-in items like vacuums, lawn equipment, and electronics, call or go on-line for the location of your nearest **Sears Parts & Repair Center.**

1-800-488-1222 Call anytime, day or night (U.S.A. only)

www.sears.com

To purchase a protection agreement (U.S.A.) or maintenance agreement (Canada) on a product serviced by Sears:

1-800-827-6655 (U.S.A.)

1-800-361-6665 (Canada)

Para pedir servicio de reparación a domicilio, y para ordenar piezas:

1-888-SU-HOGAR® (1-888-784-6427)



® Registered Trademark / ™ Trademark / ™ Service Mark of Sears Brands, LLC
® Marca Registrada / ™ Marca de Fábrica / ™ Marca de Servicio de Sears Brands, LLC

90 DAY FULL WARRANTY

If this Sears Bike Exerciser fails due to a defect in material or workmanship within 90 days of the date of purchase, call 1-800-4-MY-HOME® (1-800-469-4663) to arrange for free repair (or replacement if repair proves impossible). There is a five year warranty on the frame.

This warranty does not apply when the Bike Exerciser is used commercially or for rental purposes.

This warranty gives you specific legal rights, and you may also have other rights which vary from state to state.

Sears, Roebuck and Co., Hoffman Estates, IL 60179