

Owner's Manual

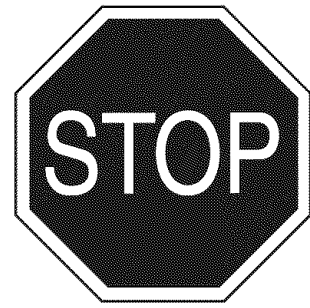

UTILITY 10 POLY CONVERTIBLE CART

Model No. 486.243201

DO NOT RETURN TO STORE
For Missing Parts or Assembly
Questions Call 1-866-576-8388

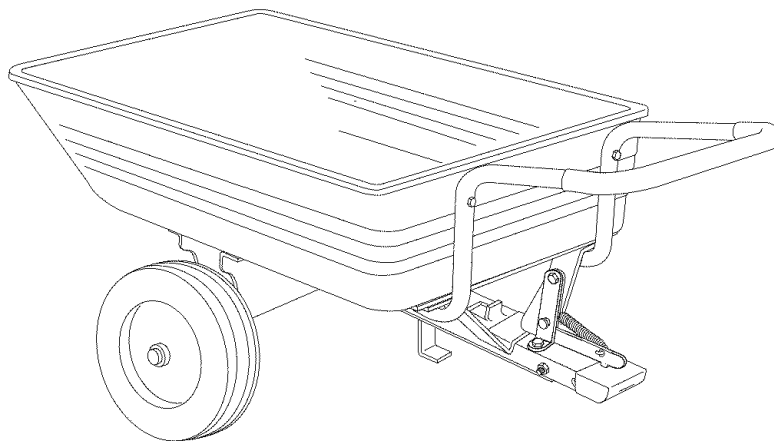

CAUTION:

Before using this product, read this manual and follow all Safety Rules and Operating Instructions.

- Safety
- Assembly
- Operation
- Maintenance
- Parts

Sears, Roebuck and Co., Hoffman Estates, IL 60179 U.S.A.
www.sears.com/craftsman

TABLE OF CONTENTS

Safety Rules	2	Maintenance	9
Warranty	2	Storage	9
Full Size Hardware Chart	3	Repair Parts Illustration	10
Assembly	4	Repair Parts List	10
Operation	8	Slope Gauge	11
		Parts Ordering/Service	Back Cover



SAFETY



Any power equipment can cause injury if operated improperly or if the user does not understand how to operate the equipment. Exercise caution at all times, when using power equipment.

- Read this owners manual before attempting to assemble or operate the cart.
- Read the vehicle owners manual and know how to operate your tractor before using the cart attachment.
- Do not at any time carry passengers in this cart. It has not been designed to carry passengers.
- Never allow children to operate the tractor or the cart attachment.
- Do not allow adults to operate the tractor or cart attachment without proper instructions.
- Always begin with the transmission in first (low) and gradually increase speed as conditions permit.
- Tow the cart at reduced speed over rough terrain and hillsides or near creeks and ditches to prevent tipping over and loss of control. Do not drive too close to a creek or ditch.
- Vehicle braking and stability may be affected with the attachment of this cart. Do not fill cart to maximum weight capacity without checking the capability of the towing vehicle to safely pull and stop with the cart attached.
- Before operating vehicle on any grade (hill) refer to safety rules in the vehicle owner's manual concerning safe operation on slopes. Refer also to the slope guide on page 11 of this manual. Be aware of changing conditions on slopes. **Stay off steep slopes!**
- Do not tow this cart on highways or public thoroughfares.
- Maximum towing speed is 10 m.p.h.
- Do not load more weight into the push cart than you can handle and control comfortably.
- Follow maintenance and lubrication instructions as outlined in this manual.



Look for this symbol to point out important safety precautions. It means — **Attention!! Become alert!!** Your safety is involved.

WARRANTY

ONE YEAR FULL WARRANTY

When operated and maintained according to the instructions supplied with it, if this Convertible Cart fails due to a defect in material or workmanship within one year from the date of purchase, call 1-800-4-MY-HOME® to arrange for free repair (or replacement if repair proves impossible).

If this product is used for commercial or rental purposes, this warranty applies for only 90 days from the date of purchase

This warranty gives you specific legal rights, and you may also have other rights which vary from state to state.

Sears, Roebuck and Co., D817WA, Hoffman Estates, IL 60179

<p>The model number and serial numbers will be found on a decal attached to the cart.</p> <p>You should record both the serial number and the date of purchase and keep in a safe place for future reference.</p>	<table style="width: 100%; border-collapse: collapse;"> <tr> <td style="width: 60%;">MODEL NUMBER:</td> <td style="width: 40%;">486.243201</td> </tr> <tr> <td>SERIAL NUMBER:</td> <td>_____</td> </tr> <tr> <td>DATE OF PURCHASE:</td> <td>_____</td> </tr> </table>	MODEL NUMBER:	486.243201	SERIAL NUMBER:	_____	DATE OF PURCHASE:	_____
MODEL NUMBER:	486.243201						
SERIAL NUMBER:	_____						
DATE OF PURCHASE:	_____						

HARDWARE PACKAGE CONTENTS

HARDWARE SHOWN FULL SIZE

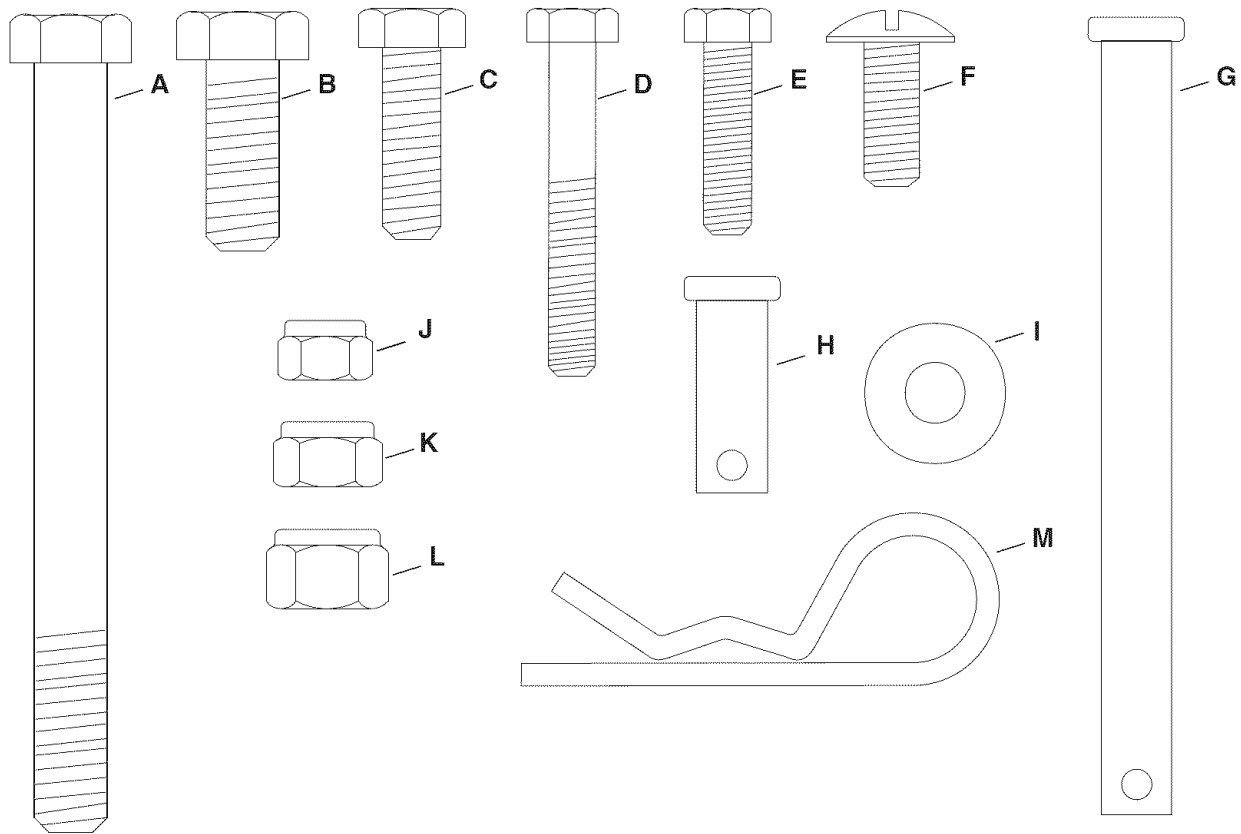

Not Shown Full Size

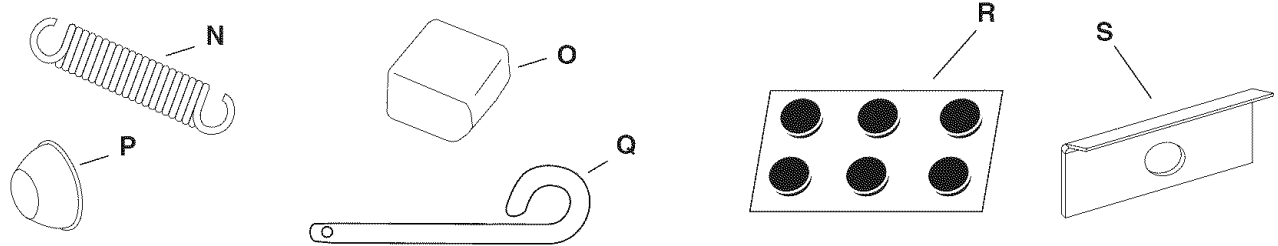

Ref. No.	Quant.	Description	Ref. No.	Quant.	Description
A	1	Hex Bolt, 3/8" x 4"	K	10	Nylock Nut, 5/16"
B	2	Hex Bolt, 3/8" x 1"	L	3	Nylock Nut, 3/8"
C	2	Hex Bolt, 5/16" x 1"	M	3	Hairpin Cotter, 1/8"
D	6	Hex Bolt, 1/4" x 1-3/4"	N	1	Extension Spring
E	3	Hex Bolt, 1/4" x 1"	O	1	Plastic Cap
F	8	Truss Head Bolt, 5/16" x 3/4" Lg.	P	2	Hub Cap
G	1	Clevis Pin, 3/8" x 4"	Q	1	Hitch Pin
H	1	Clevis Pin, 3/8" x 1"	R	6	Noise Reduction Pad
I	6	Flat Washer, 1/4"	S	2	Axle Clip
J	9	Nylock Nut, 1/4"			

ASSEMBLY

CARTON CONTENTS (Loose Parts in Carton)

- | | | |
|----------------------|------------------------------|-------------------|
| 1. Poly Tray | 6. Latch Stand Bracket | 11. Wheel Support |
| 2. Handle Tube | 7. Hitch Bracket | 12. Axle |
| 3. Front Tongue | 8. Leg Stand Bracket | 13. Wheels (2) |
| 4. Rear Tongue | 9. Latch Lock | 14. Handle Grip |
| 5. Latch Stand Plate | 10. Latch Mount Brackets (2) | |

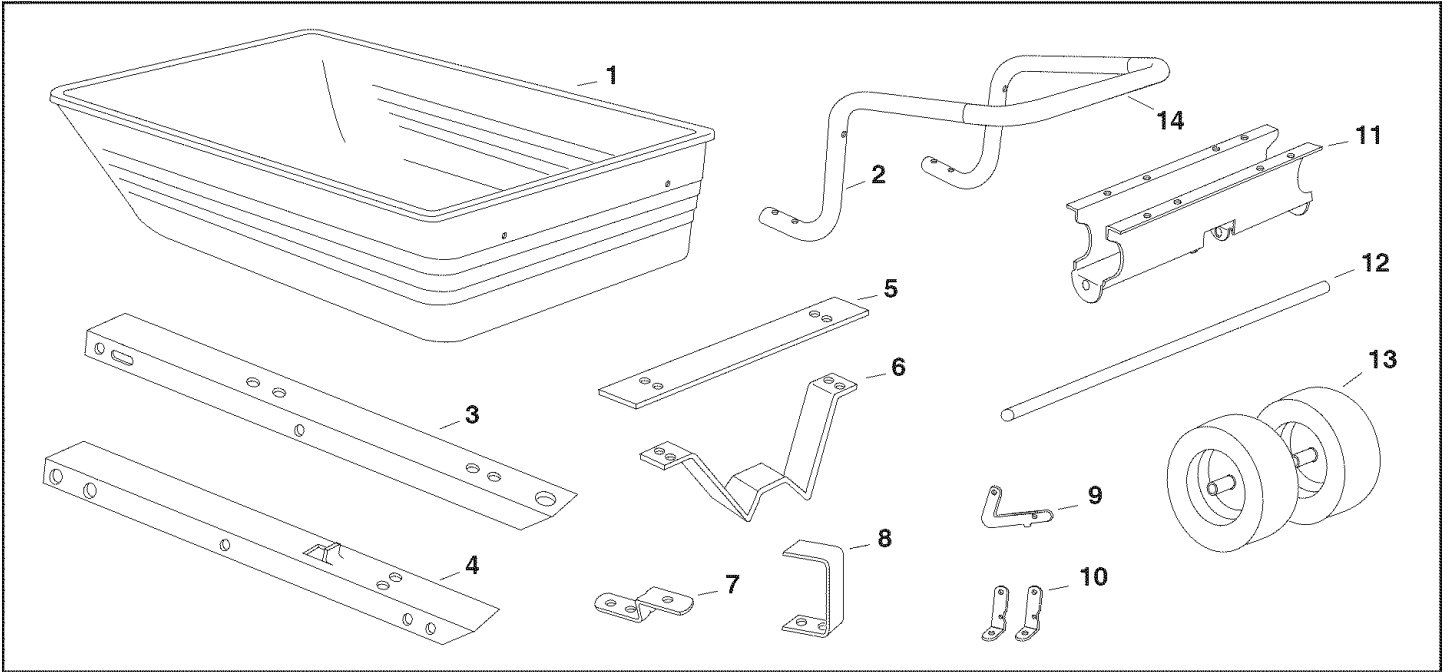

CARTON CONTENTS

TOOLS REQUIRED FOR ASSEMBLY

- (1) Screwdriver
- (1) Pliers
- (2) 7/16" Wrenches
- (2) 1/2" Wrenches
- (2) 9/16" Wrenches

- Remove the hardware pack and all loose parts from the carton. Be sure the carton is empty before discarding.
- Lay out all the parts shown on pages 3 and 4.

NOTE: All 1/4" flat washers should be assembled so that they rest directly against the poly tray surface.

STEP 1: (SEE FIGURE 1)

- Assemble the latch lock between the latch mount brackets using a 1/4" x 1" hex bolt (E) and a 1/4" nylock nut (J). Tighten so that the latch lock can still pivot. Attach the extension spring (N) to the latch lock and the latch mount bracket.

- Insert the 3/8" x 1" clevis pin (H) through the holes in the latch mount brackets and secure with an 1/8" hairpin cotter (M).

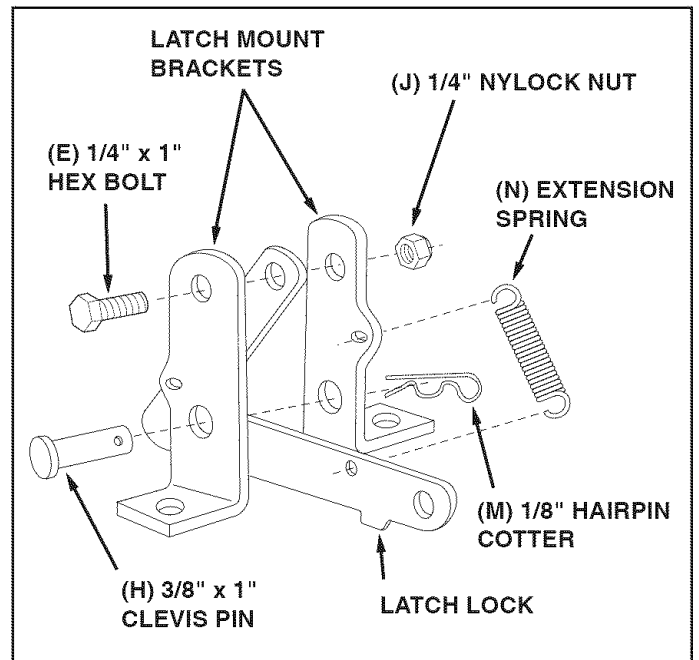

FIGURE 1

STEP 2: (SEE FIGURE 2)

- Assemble the latch lock subassembly to the rear tongue using two 1/4" x 1" hex bolts (E) and 1/4" nylock nuts (J). **Tighten.**
- Assemble the plastic cap (O) to the front end of the rear tongue.

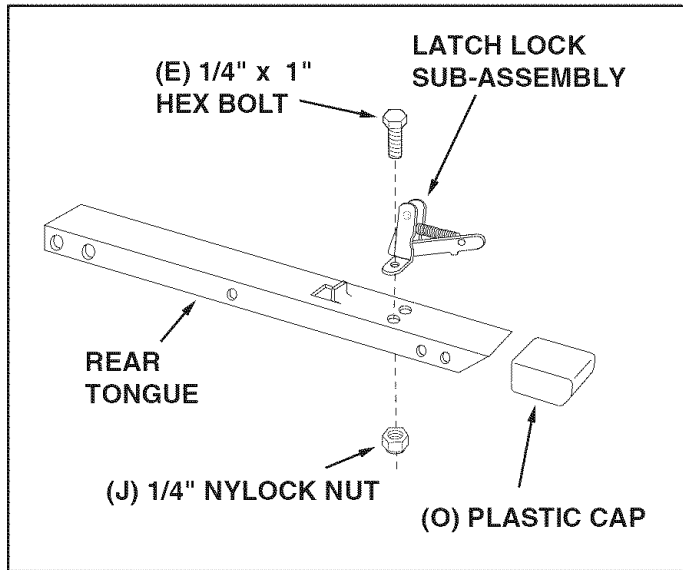

FIGURE 2

STEP 3: (SEE FIGURE 3)

- Lay the rear tongue (open side facing up) onto the Wheel Support. Assemble the axle through the wheel support and the second hole from the end of the tongue.

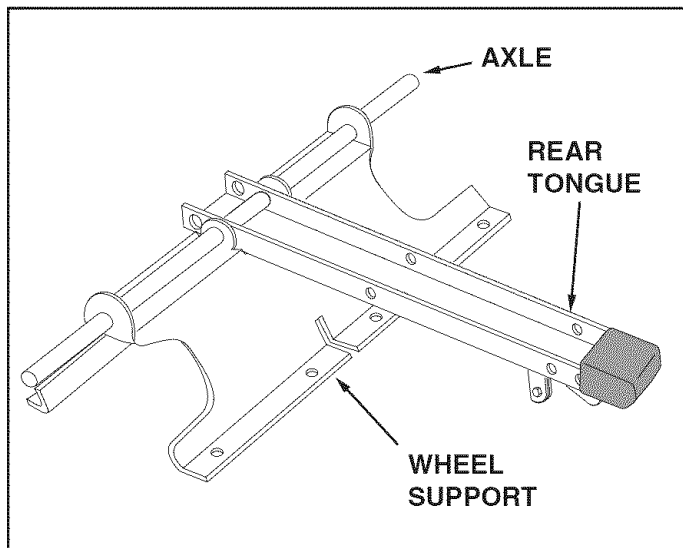

FIGURE 3

STEP 4: (SEE FIGURE 4)

- Assemble the hitch bracket to the front tongue using two 3/8" x 1" hex bolts (B) and 3/8" hex nylock nuts (L). **Tighten.**
- Assemble the leg stand bracket to the front tongue using two 5/16" x 1" hex bolts (C) and 5/16" nylock nuts (K). **Tighten.**

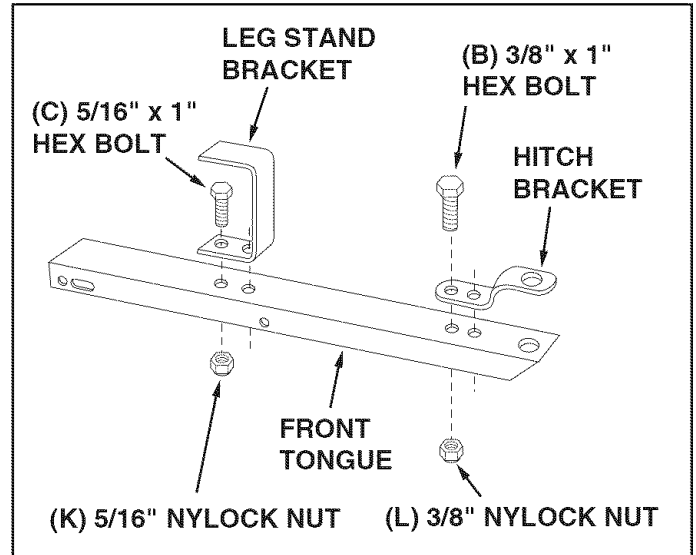

FIGURE 4

STEP 5: (SEE FIGURE 5)

- Place the front tongue inside the rear tongue as shown in figure 5. Fasten the tongues together using a 3/8" x 4" hex bolt (A) and a 3/8" nylock nut (L). **Tighten,** leaving the nut just loose enough that the tongues can pivot freely.
- Insert the 3/8" x 4" clevis pin (G) through the tongues and secure with a 1/8" hairpin cotter (M).

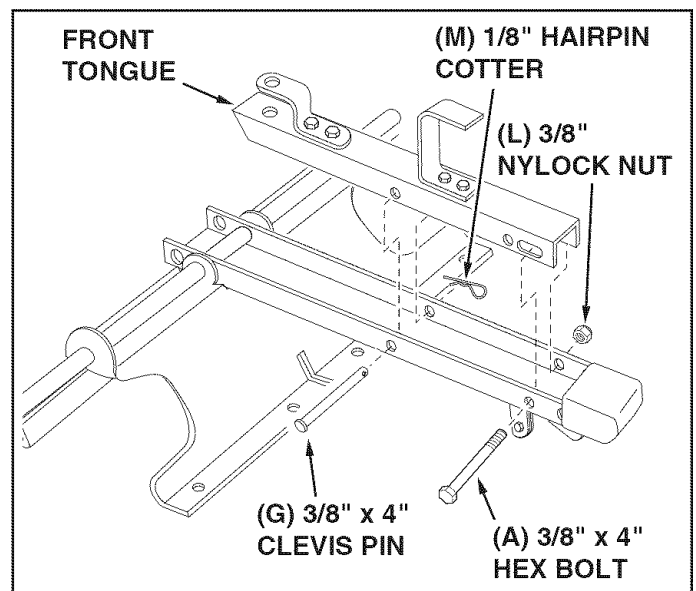

FIGURE 5

STEP 6: (SEE FIGURE 6)

- Assemble an axle clip (S) and a wheel with the valve stem facing out onto the axle. Assemble a hub cap (P) by pressing or tapping it onto the axle. Repeat on other end of axle.

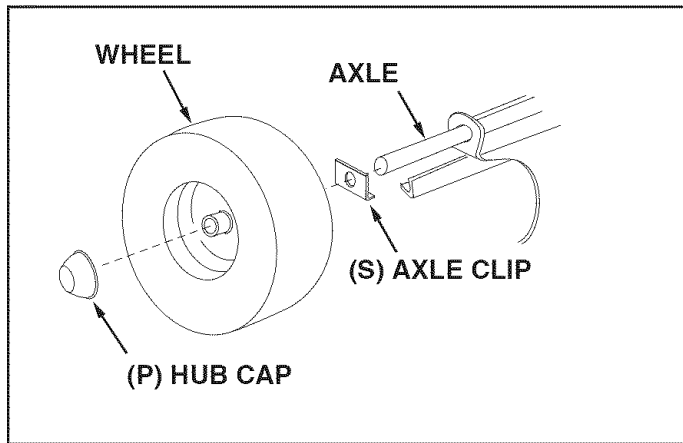

FIGURE 6

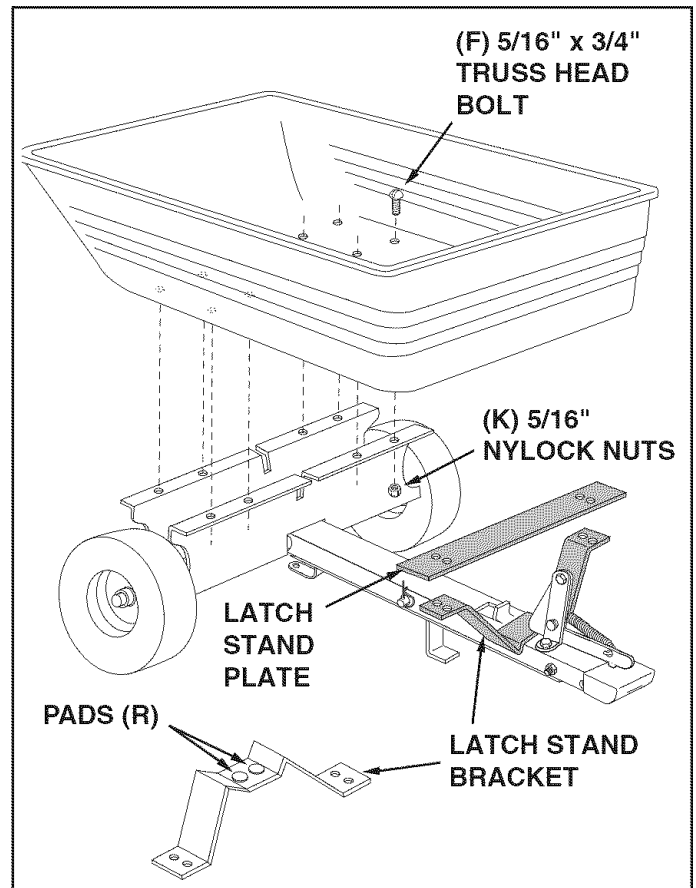

FIGURE 7

STEP 7: (SEE FIGURE 7)

- Attach two noise reduction pads (R) to the bottom of the latch stand bracket.
- Turn the assembled tongue, wheel support and wheels over to the upright position. Place the latch stand bracket onto the tongue between the latch lock assembly and the raised tab. Place the poly tray onto the wheel support and latch stand bracket. Fasten the tray to the wheel support using eight 5/16" x 3/4" truss head bolts (F) and 5/16" nylock nuts (K). **Do not tighten yet.**
- Place the latch stand plate between the latch stand bracket and the poly tray.

STEP 8: (SEE FIGURE 8)

- Insert two 1/4" x 1-3/4" hex bolts (D) through the handle tube as shown in figure 8. Holding the bolts in place in the handle, insert the bolts through the holes in the poly tray, allowing the legs of the handle to slip beneath the latch stand bracket. Secure the two bolts with two 1/4" flat washers (I) and 1/4" nylock nuts (J). **Do not tighten yet.**

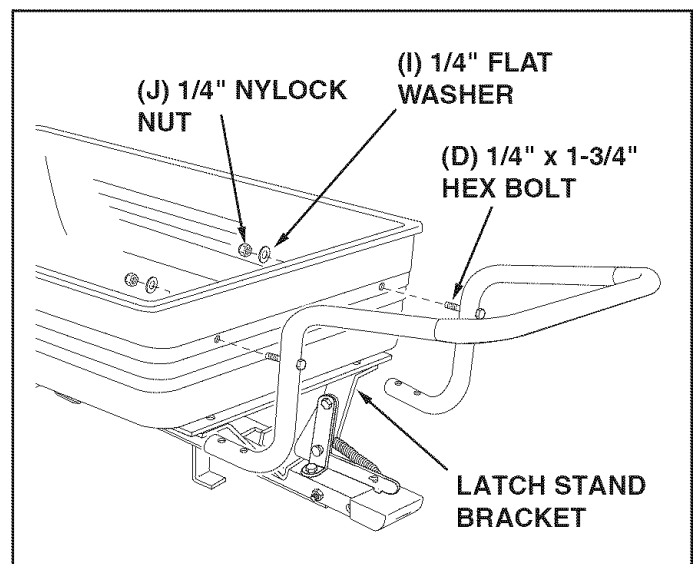

FIGURE 8

STEP 9: (SEE FIGURE 9)

- Align the holes in the handle with the holes in the bottom of the poly tray, the latch stand plate and the latch stand bracket. Fasten together using four 1/4" x 1-3/4" hex bolts (D), 1/4" flat washers (I) and 1/4" nylock nuts (J). **Tighten.**
- At this time **tighten** all bolts which were left loose.

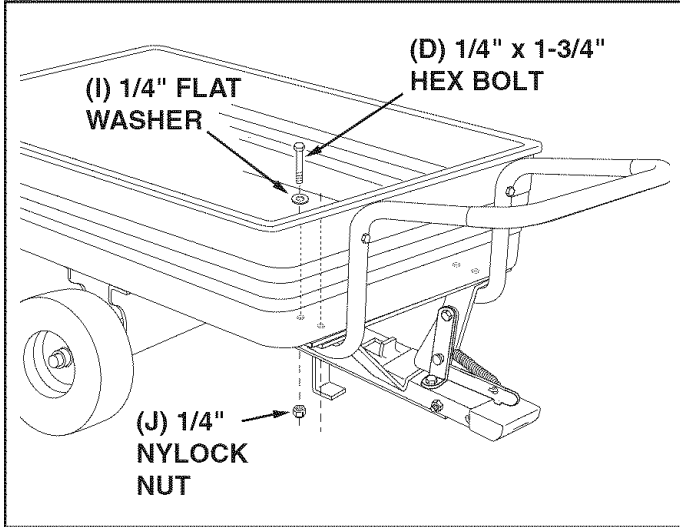

FIGURE 9

CART WITH TONGUE ARRANGED FOR TOWING

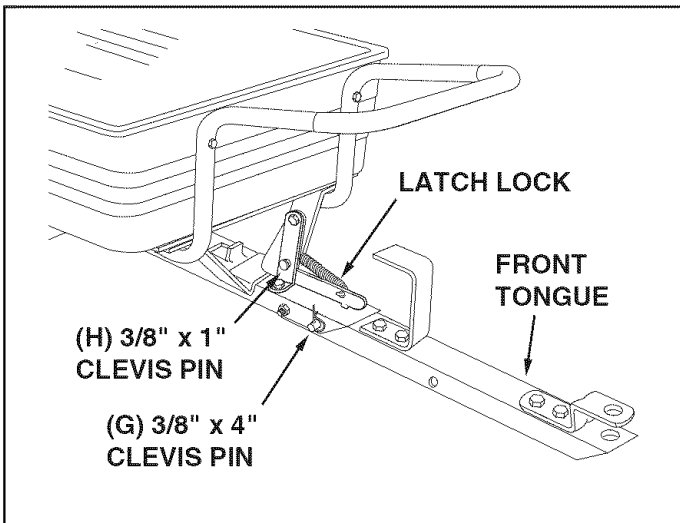

FIGURE 10

STEP 10: (SEE FIGURE 11)

- Assemble the hitch pin (Q) through the tongue and hitch bracket and secure it with the 1/8" hairpin cotter (M).

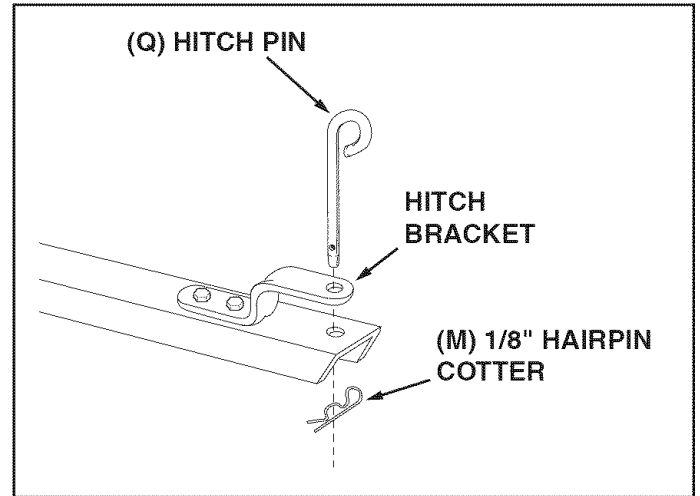

FIGURE 11

STEP 11: (SEE FIGURE 12)

- Attach two noise reduction pads (R) on each side of the front tongue.

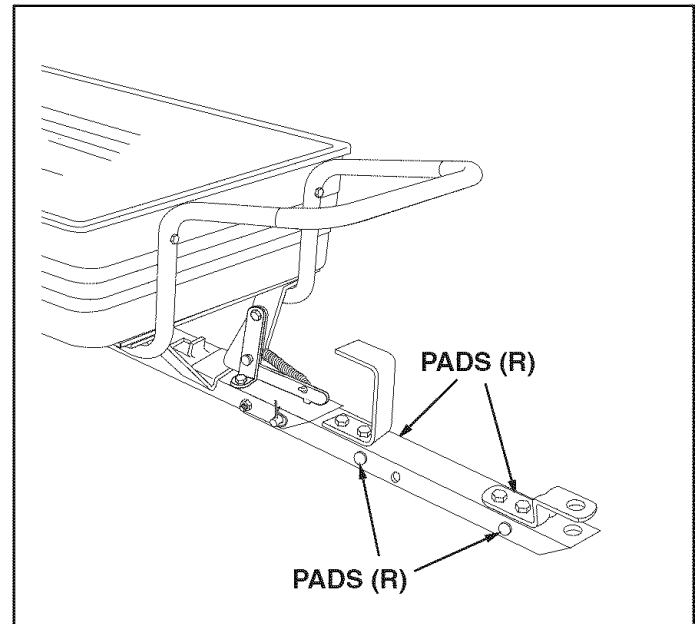
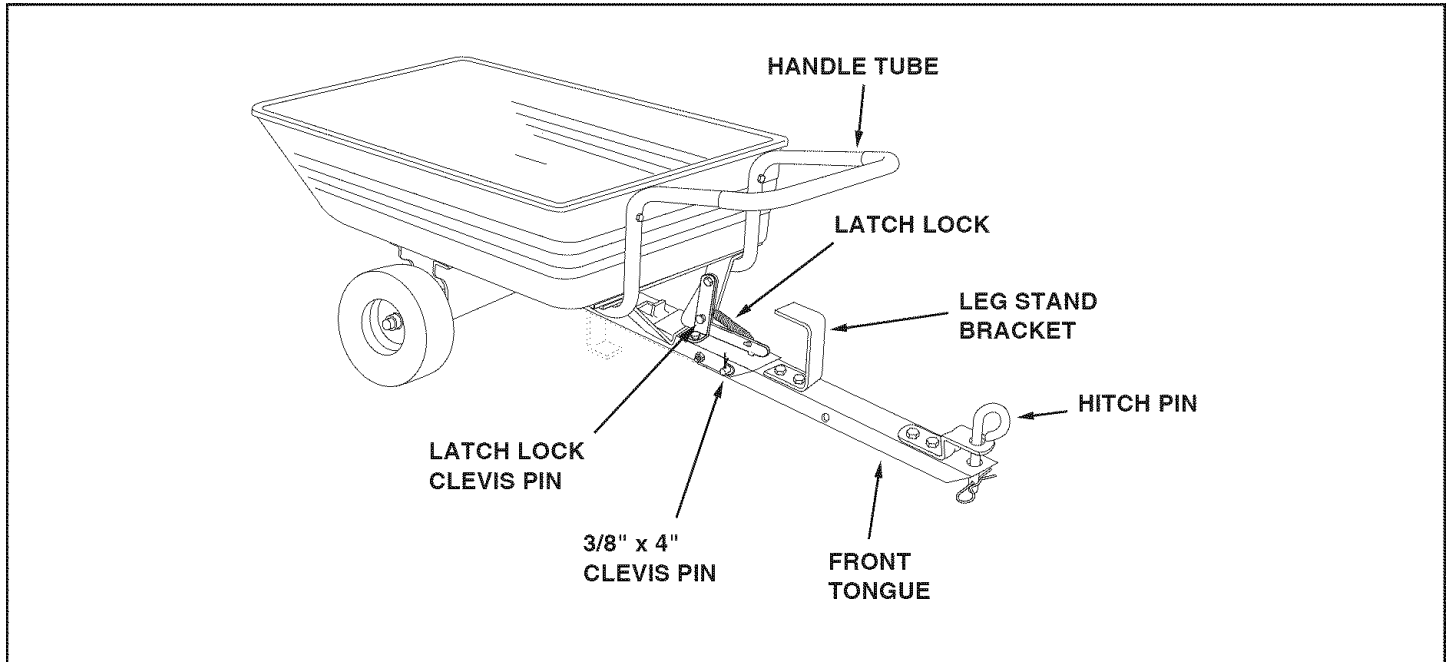

FIGURE 12

OPERATION

KNOW YOUR CART



HANDLE TUBE
LATCH LOCK
FRONT TONGUE
LEG STAND BRACKET
HITCH PIN
3/8" x 4" CLEVIS PIN
LATCH LOCK CLEVIS PIN

Used to transport and dump the cart when it is converted into a push cart.
Secures the cart bed to the tongue.
Extends forward or folds under the cart for towing with a tractor or pushing by hand.
Supports the front of the cart when the front tongue is folded under the cart.
Use to attach the cart to your tractor.
Secures the front tongue in either the extended (shown) or folded position.
Prevents the latch lock mechanism from accidentally releasing.

HOW TO USE YOUR TOW CART

DO NOT EXCEED 500 LB. CAPACITY OF CART

One cubic foot of dirt weighs approximately 80 lbs.



CAUTION: Vehicle braking and stability may be affected with the addition of an accessory or attachment. Be aware of changing conditions on slopes.

USING AS A TOW CART

- To convert the cart for towing, remove the plastic cap from the tongue. Remove the 4" long clevis pin and hairpin cotter which secure the front tongue in storage position underneath the rear tongue. Pivot the front tongue outward and secure it in the towing position using the same clevis pin and hairpin cotter. Refer to drawing above.
- The maximum towing speed for this cart is 10 m.p.h.
- Refer to the vehicle owners manual for instructions on safe operation on slopes.

- Use the slope guide provided on page 11 of this manual to determine whether slope angle is too steep for safe operation.
- Always test to make sure your tractor has adequate towing and braking capabilities whenever hauling a substantial amount of weight in your cart. Use extra caution when operating on slopes.
- For best handling and traction, distribute the weight of the load evenly in the cart.
- To dump material from the cart, remove the 1" long clevis pin from the latch on the tongue and release the latch. The cart bed will then tilt backwards to empty its contents. After emptying, pull the front of the bed down toward the cart tongue until the latch snaps into place. Reinstall the clevis pin in the latch to prevent accidental release of the latch.



CAUTION: To avoid possible injury, be sure no one is near the cart before releasing the latch.

USING AS A PUSH CART

IMPORTANT: Leave the latch lock clevis pin in place at all times while using the cart as a push cart. The clevis pin is shown in figure 1 on page 4.

- To convert the cart for push operation, remove the 4" long clevis pin and hairpin cotter which secure the tongue in the towing position. (See drawing on page 8.) Pivot the front tongue into the storage position underneath the rear tongue and secure it using the same clevis pin and hairpin cotter. (See figure 5 on page 5.) Place the plastic cap over the exposed end of the tongue.

- For best handling, and to help prevent accidental tipping, distribute the weight of the load evenly in the cart.
- Do not load more weight into the push cart than you can handle and control comfortably.
- To dump material from the push cart, lift up on the handle and tilt the cart forward. **Be sure** that the latch mechanism on the tongue is locked and secured with the clevis pin to prevent accidental release of the latch.

MAINTENANCE/STORAGE

CUSTOMER RESPONSIBILITIES

- Read and follow the maintenance schedule and the procedures listed in the maintenance section.

MAINTENANCE SCHEDULE Fill in dates as you complete regular service.	Service Dates																			
	Before each use	After each use	Twice a year	Every season	Before storage															
Check for loose fasteners	X																			
Check for worn or damaged parts	X																			
Check tire pressure	X																			
Lubricate				X																
Clean		X			X															

SCHEDULED MAINTENANCE

- Check for loose fasteners before each use.
- Check for worn or damaged parts before each use.
- Keep tires filled to recommended tire pressure printed on the tire.



CAUTION: DO NOT inflate tires beyond the maximum recommended pressure printed on side of tire.

- At the beginning of each season, using a light machine oil, lubricate the latch, the latch pivot bolt, and the area of the axle where the draw bar tongue pivots. See figure 13.
- Grease or oil the wheel bearings periodically (at least once each season). Use grease or 20 weight oil. See figure 13.

STORAGE

- Clean thoroughly before storing.
- Remove any rust from painted surfaces and coat with touch up paint.
- Store in a dry area.

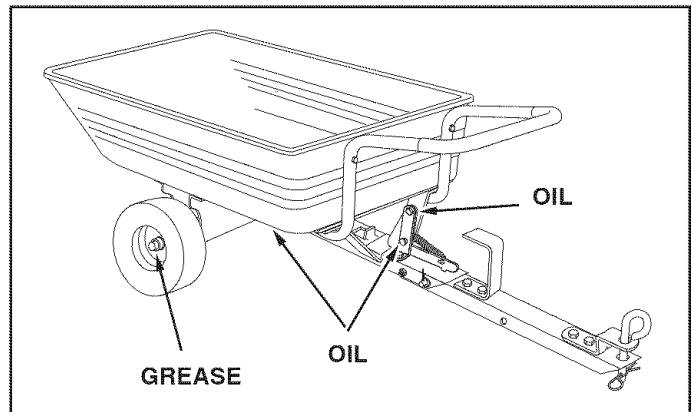
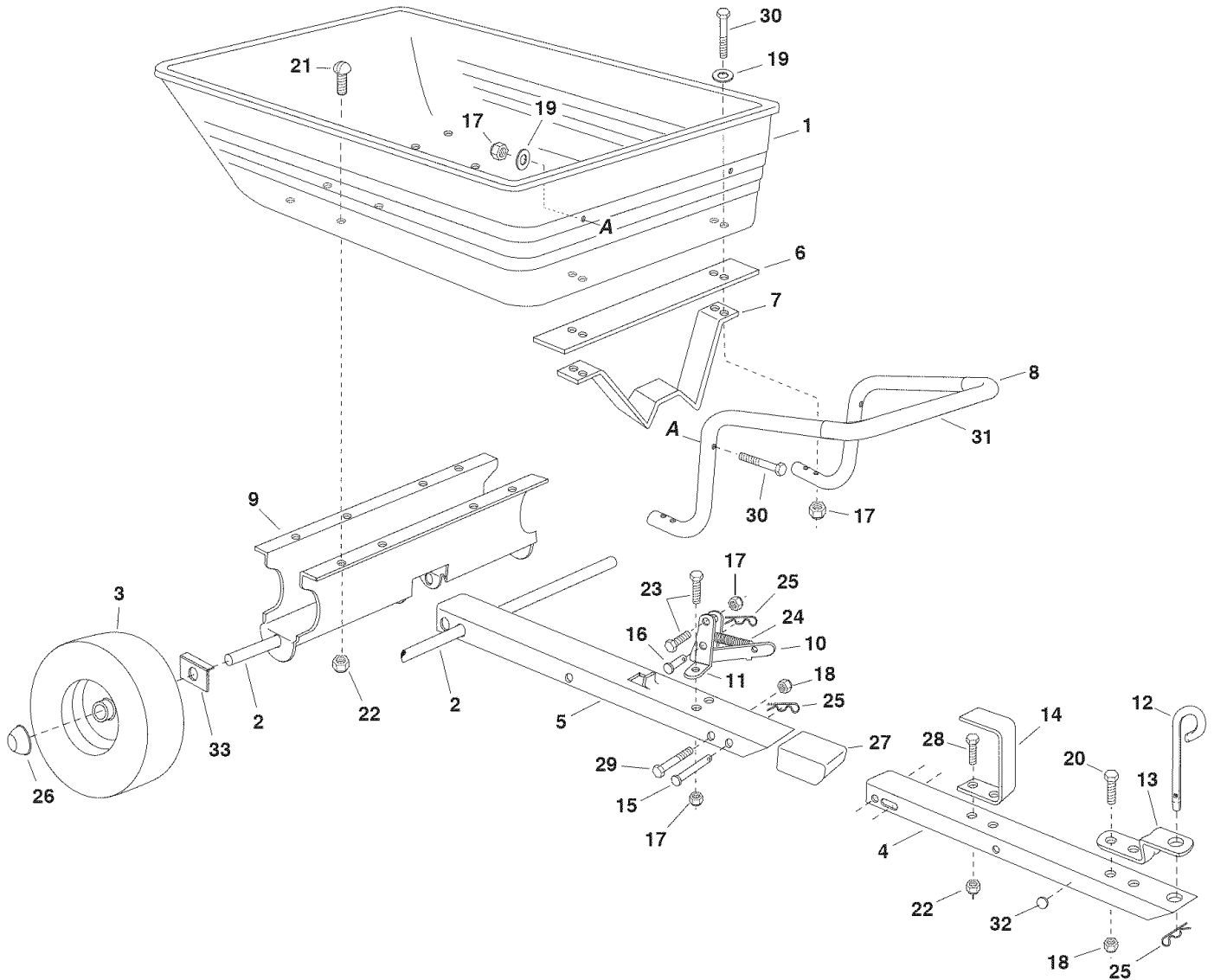

FIGURE 13

CART SPECIFICATIONS

Tires:	14" x 4" Pneumatic
Axle:	5/8" Dia. Steel
Capacity:	Up to 500 Lbs. Max.
Approx. Sh. Wt.	55 Lbs.

PARTS



REF NO	PART NO	QTY	DESCRIPTION	REF NO	PART NO	QTY	DESCRIPTION
1	48791	1	Poly Tray	18	HA21362	3	Nylock Nut, 3/8-16 Thread *
2	24908	1	Axle	19	43088	6	Washer, Flat 1/4" Std. Wrought
3	48497	2	Wheel Assembly	20	43001	2	Hex Bolt, 3/8-16 x 1" Lg. *
4	24392	1	Tongue, Front	21	43814	8	Truss Hd Bolt, 5/16-18 x 3/4" Lg.*
5	24391	1	Tongue, Rear	22	47810	10	Nylock Nut, 5/16-18 Thread *
6	24386	1	Latch Stand Plate	23	43661	3	Hex Bolt, 1/4-20 x 1" *
7	23297	1	Latch Stand Bracket	24	43000	1	Extension Spring
8	48834	1	Handle Tube	25	43343	3	Hairpin, Cotter 1/8"
9	24527	1	Wheel Support	26	48499	2	Hub Cap
10	62020	1	Latch Lock	27	47038	1	Plastic Cap
11	23470	2	Bracket, Latch Mounting	28	43063	2	Hex Bolt, 5/16-18 x 1" Lg. *
12	23353	1	Hitch Pin	29	43036	1	Hex Bolt, 3/8-16 x 4" Lg. *
13	23014	1	Hitch Bracket	30	1509-69	6	Hex Bolt, 1/4-20 x 1-3/4" Lg. *
14	24390	1	Leg Stand Bracket	31	48836	1	Foam Grip
15	47029	1	Clevis Pin, 3/8" x 4"	32	48661	6	Noise Reduction Pad
16	45091	1	Clevis Pin 3/8" x 1"	33	25910	2	Axle Clip, 5/8"
17	47189	9	Nylock Nut 1/4-20 Thread *		40303	1	Owner's Manual

SUGGESTED GUIDE FOR SIGHTING SLOPES FOR SAFE OPERATION OF TRACTOR WITH ATTACHMENT

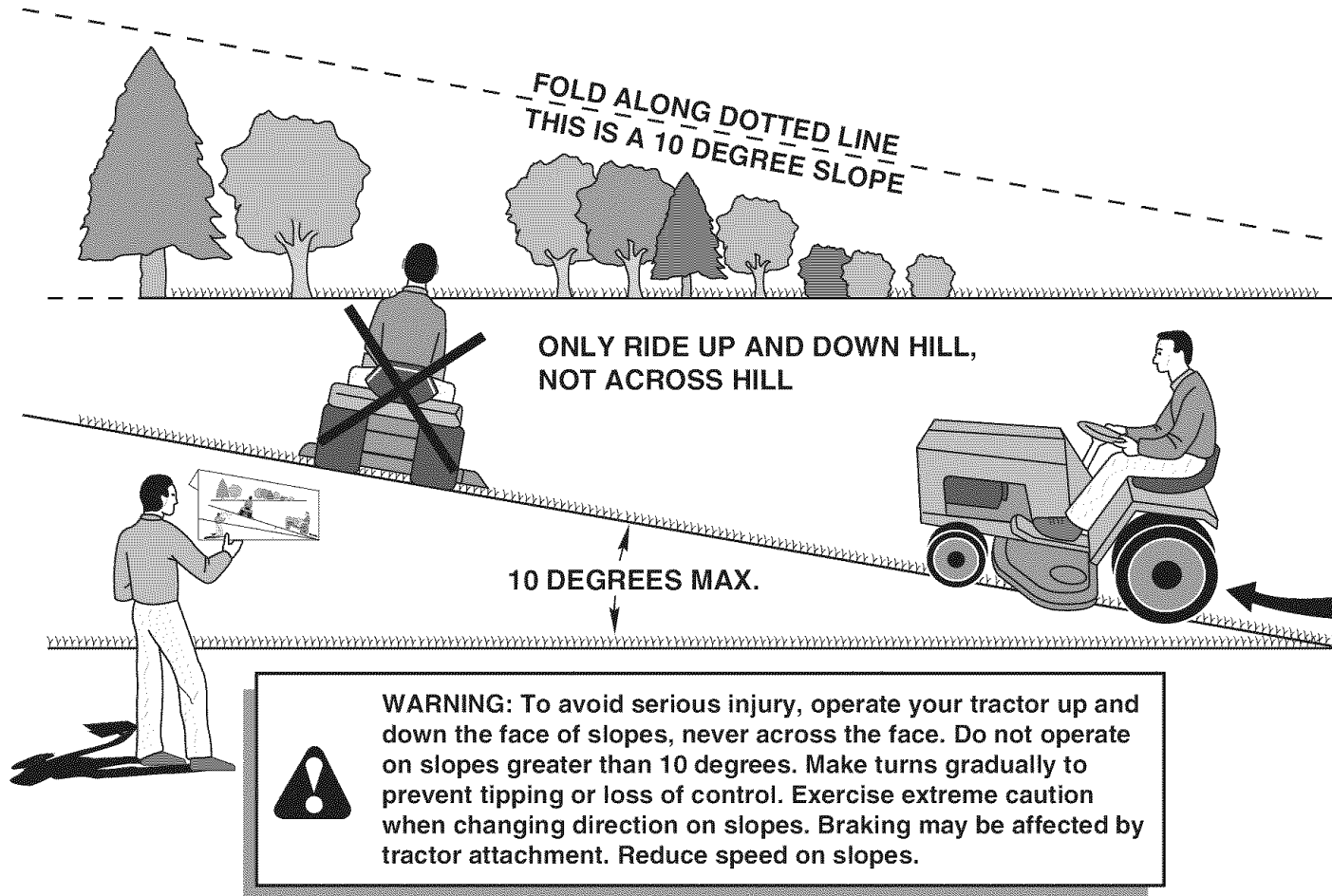

1. Fold this page along dotted line indicated above.
2. Hold page before you so that its left edge is vertically parallel to a tree trunk or other upright structure.
3. Sight across the fold in the direction of hill slope you want to measure.
4. Compare the angle of the fold with the slope of the hill.

Get it fixed, at your home or ours!

Your Home

For repair – **in your home** – of **all** major brand appliances, lawn and garden equipment, or heating and cooling systems, **no matter who made it, no matter who sold it!**

For the replacement parts, accessories and owner's manuals that you need to do-it-yourself.

For Sears professional installation of home appliances and items like garage door openers and water heaters.

1-800-4-MY-HOME® (1-800-469-4663)

Call anytime, day or night (U.S.A. and Canada)

www.sears.com www.sears.ca

Our Home

For repair of carry-in items like vacuums, lawn equipment, and electronics, call or go on-line for the location of your nearest **Sears Parts & Repair Center.**

1-800-488-1222

Call anytime, day or night (U.S.A. only)

www.sears.com

To purchase a protection agreement (U.S.A.) or maintenance agreement (Canada) on a product serviced by Sears:

1-800-827-6655 (U.S.A.)

1-800-361-6665 (Canada)

Para pedir servicio de reparación a domicilio, y para ordenar piezas:

1-888-SU-HOGAR®

(1-888-784-6427)

Au Canada pour service en français:

1-800-LE-FOYER^{MC}

(1-800-533-6937)

www.sears.ca

The Sears logo is displayed in a large, stylized font. The word "Sears" is written in a bold, serif typeface. A horizontal line is positioned below the letters "e" and "a", extending from the left side of the "e" to the right side of the "a".