



Coin-Operated Commercial Automatic Washer

Installation Instructions and
Use and Care Guide

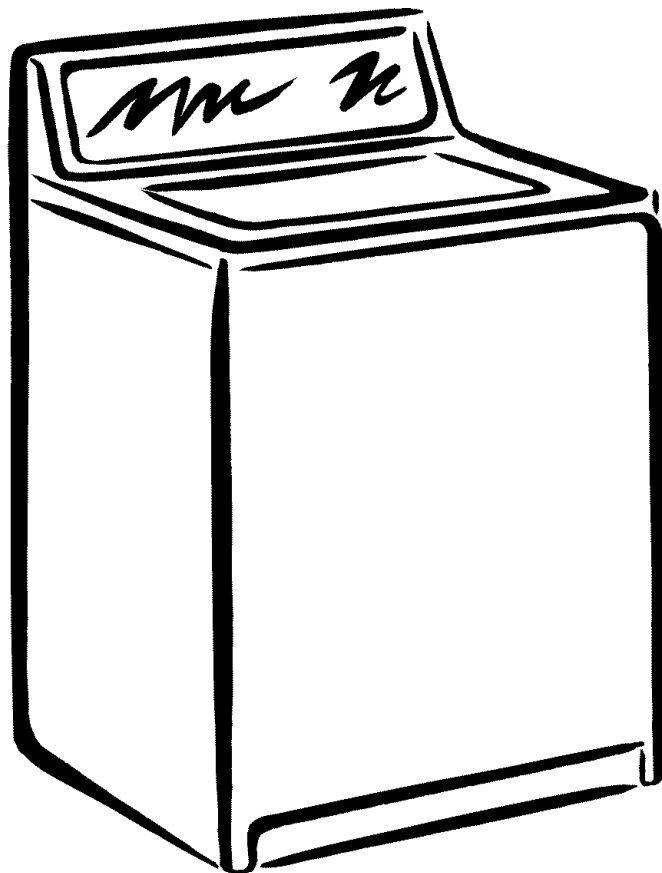

TABLE OF CONTENTS

PRODUCT RECORD	2	Level the Washer	8
WASHER SAFETY	2	Complete Installation.....	9
INSTALLATION REQUIREMENTS	3	Adjusting Timer Clutch	9
Tools and Parts	3	Washer Cabinet	10
Location Requirements	4	Changing Vend Price.....	10
Drain System	4	WASHER USE	11
Electrical Requirements.....	5	WASHER CARE	12
INSTALLATION INSTRUCTIONS	6	Before Transporting Washer to a New Location.....	12
Before You Start.....	6	TROUBLESHOOTING	13
Remove Shipping Strap	6	Washer and Components	13
Connect Drain Hose	6	NEW VEND PRICE	13
Connect the Inlet Hoses	7	Order Form	13
Secure the Drain Hose	8	Washer Operation.....	14
Install Coin Slide Mechanism.....	8	Washer Results.....	15

Product Record

For Sears warranty information or to contact a Sears Service Center, call **1-800-4-MY HOMESM (1-800-469-4663)**.

If you need service or parts for your Kenmore coin-operated washer:

When requesting service, be ready to give the model number, serial number (located on a plate under the lid) and date of purchase. Record below.

Model number **110**

Serial number

Purchase date

Record Coin Box Key Number

Key number is on key and/or coin box.

WASHER SAFETY

Your safety and the safety of others are very important.

We have provided many important safety messages in this manual and on your appliance. Always read and obey all safety messages.



This is the safety alert symbol.

This symbol alerts you to potential hazards that can kill or hurt you and others.

All safety messages will follow the safety alert symbol and either the word "DANGER" or "WARNING."

These words mean:

▲ DANGER

You can be killed or seriously injured if you don't immediately follow instructions.

▲ WARNING

You can be killed or seriously injured if you don't follow instructions.

All safety messages will tell you what the potential hazard is, tell you how to reduce the chance of injury, and tell you what can happen if the instructions are not followed.

IMPORTANT SAFETY INSTRUCTIONS

WARNING: To reduce the risk of fire, electric shock, or injury to persons when using the washer, follow basic precautions, including the following:

- Read all instructions before using the washer.
- Do not wash articles that have been previously cleaned in, washed in, soaked in, or spotted with gasoline, dry-cleaning solvents, other flammable, or explosive substances as they give off vapors that could ignite or explode.
- Do not add gasoline, dry-cleaning solvents, or other flammable, or explosive substances to the wash water. These substances give off vapors that could ignite or explode.
- Under certain conditions, hydrogen gas may be produced in a hot water system that has not been used for 2 weeks or more. **HYDROGEN GAS IS EXPLOSIVE.** If the hot water system has not been used for such a period, before using the washing machine, turn on all hot water faucets and let the water flow from each for several minutes. This will release any accumulated hydrogen gas. As the gas is flammable, do not smoke or use an open flame during this time.
- Do not allow children to play on or in the washer. Close supervision of children is necessary when the washer is used near children.
- Before the washer is removed from service or discarded, remove the door or lid.
- Do not reach into the washer if the drum, tub or agitator is moving.
- Do not install or store the washer where it will be exposed to the weather.
- Do not tamper with controls.
- Do not repair or replace any part of the washer or attempt any servicing unless specifically recommended in this manual or in published user-repair instructions that you understand and have the skills to carry out.
- See "Electrical Requirements" for grounding instructions.

SAVE THESE INSTRUCTIONS

INSTALLATION REQUIREMENTS

Tools and Parts

Gather the required tools and parts before starting installation. The parts supplied are in the washer basket.

Tools needed for connecting the drain hose and water inlet hoses:

- Pliers that open to 1 $\frac{1}{16}$ " (3.95 cm)
- Flashlight (optional)

Parts supplied:

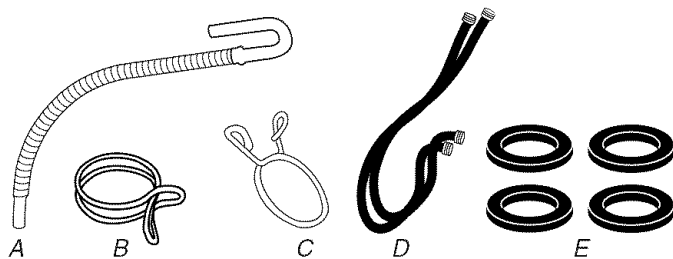

- A. Drain hose
- B. Silver, double-wire hose clamp (for the bottom of the drain hose)
- C. Yellow, single-wire hose clamp (for the top of the drain hose)
- D. Water inlet hoses (2)
- E. Flat water inlet hose washers (4)

Tools needed for securing the drain hose and leveling the washer:

- Adjustable or open end wrench $\frac{9}{16}$ " (14 mm)
- Level
- Wood block
- Ruler or measuring tape

Parts supplied:

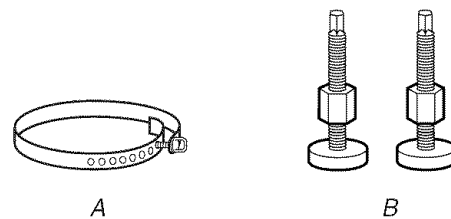

- A. Shipping strap with fastener
- B. Front leveling feet with nuts (2)

Tools needed for installing coin slide mechanism and removing/replacing cabinet:

- Ratchet wrench and a $\frac{5}{16}$ " (8 mm) socket
- Regular screwdriver
- #2 Phillips screwdriver

Alternate Parts

Parts listed are available from your local Sears store or Sears Service Center. For further information, call **1-800-4-MY-HOME® (1-800-469-4663)**.

If You Have:	You Will Need to Buy:
Floor drain	Siphon break, Part Number 285320; additional drain hose, Part Number 3357090 and connector kit, Part Number 285442
Drain hose too short	Drain hose, Part Number 285442
Change Vend Price *	Up to 7 quarters and 1 dime, Part Number 20-3007 Up to 8 quarters and 0 dimes, Part Number 20-3006
Gearcase Lubricant	SAE 60 Non-Detergent, Non-Foaming Motor oil, 1 pint (473.2 mL), Part Number 350572

*Unless otherwise ordered, all coin chutes are supplied with Part Number 20-3006 in place.

Location Requirements

Selecting the proper location for your washer improves performance and minimizes noise and possible washer "walk." Your washer can be installed in a basement, laundry room, closet, or recessed area. See "Drain System."

IMPORTANT: Do not install or store the washer where it will be exposed to the weather.

Proper installation is your responsibility.

You will need:

- A water heater set to deliver 120°F (49°C) water to the washer.
- A grounded electrical outlet located within 4 ft (1.2 m) of where the power cord is attached to the back of the washer. See "Electrical Requirements."
- Hot and cold water faucets located within 4 ft (1.2 m) of the hot and cold water fill valves, and water pressure of 10-100 psi (34.5-690 kPa). 20-100 psi (138-690 kPa) for best performance.
- A level floor with a maximum slope of 1" (2.5 cm) under entire washer. Installing the washer on carpeting is not recommended.
- A sturdy floor to support the washer weight (washer, water and load) of 315 lbs (143 kg).

Do not store or operate your washer in temperatures at or below 32°F (0°C). Some water can remain in the washer and can cause damage in low temperatures.

Recessed area or closet installation

The dimensions shown are for the recommended spacing allowed (A and B), except the closet door ventilation openings. The dimensions shown for the closet door ventilation openings (C) are the minimum required.

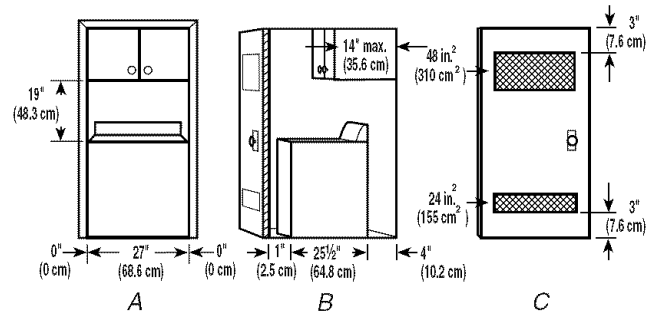

A. Front view
B. Side view
C. Closet door with vents

- Additional spacing should be considered for ease of installation and servicing.
- Additional clearances may be required for wall, door and floor moldings.
- Additional spacing of 1" (2.5 cm) on all sides of the washer is recommended to reduce noise transfer.
- If a closet door is installed, the minimum air openings in the top and bottom of the door are required (C). Louvered doors with air openings in the top and bottom are acceptable.
- Companion appliance spacing should also be considered.

Drain System

The washer can be installed using the standpipe drain system (floor or wall), the laundry tub drain system, or the floor drain system. Select the drain hose installation method you need. See "Tool and Parts."

Standpipe drain system - wall or floor (views A & B)

The standpipe drain requires a minimum diameter standpipe of 2" (5 cm). The minimum carry-away capacity can be no less than 17 gal. (64 L) per minute.

The top of the standpipe must be at least 39" (99 cm) high and no higher than 96" (244 cm) from the bottom of the washer.

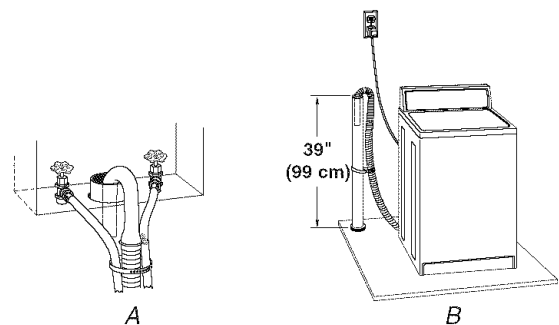

Laundry tub drain system (view C)

The laundry tub needs a minimum 20 gal. (76 L) capacity. The top of the laundry tub must be at least 39" (99 cm) above the floor and no higher than 96" (244 cm) from the bottom of the washer.

Floor drain system (view D)

The floor drain system requires a siphon break that may be purchased separately. See "Tools and Parts."

The siphon break must be a minimum of 28" (71 cm) from the bottom of the washer. Additional hoses might be needed.

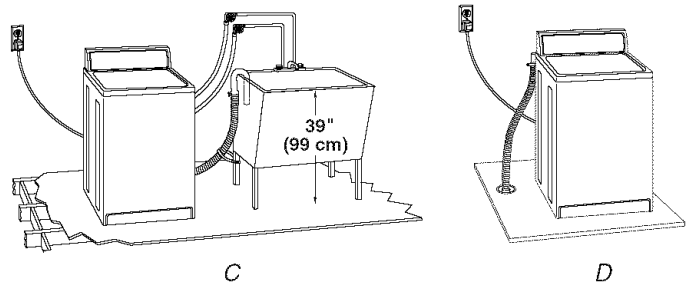

Electrical Requirements

⚠ WARNING



Electrical Shock Hazard

Plug into a grounded 3 prong outlet.

Do not remove ground prong.

Do not use an adapter.

Do not use an extension cord.

Failure to follow these instructions can result in death, fire, or electrical shock.

- A 120 volt, 60 Hz., AC only, 15- or 20-amp, fused electrical supply is required. A time-delay fuse or circuit breaker is recommended. It is recommended that a separate circuit serving only this appliance be provided.
- This washer is equipped with a power supply cord having a 3 prong grounding plug.
- To minimize possible shock hazard, the cord must be plugged into a mating, 3 prong, grounding-type outlet, grounded in accordance with local codes and ordinances. If a mating outlet is not available, it is the personal responsibility and obligation of the customer to have the properly grounded outlet installed by a qualified electrician.
- If codes permit and a separate ground wire is used, it is recommended that a qualified electrician determine that the ground path is adequate.

- Do not ground to a gas pipe.
- Check with a qualified electrician if you are not sure the washer is properly grounded.
- Do not have a fuse in the neutral or ground circuit.

GROUNDING INSTRUCTIONS

For a grounded, cord-connected washer:

This washer must be grounded. In the event of a malfunction or breakdown, grounding will reduce the risk of electrical shock by providing a path of least resistance for electric current. This washer is equipped with a cord having an equipment-grounding conductor and a grounding plug. The plug must be plugged into an appropriate outlet that is properly installed and grounded in accordance with all local codes and ordinances.

WARNING: Improper connection of the equipment-grounding conductor can result in a risk of electric shock. Check with a qualified electrician or serviceman if you are in doubt as to whether the appliance is properly grounded.

Do not modify the plug provided with the appliance – if it will not fit the outlet, have a proper outlet installed by a qualified electrician.

For a permanently connected washer:

This washer must be connected to a grounded metal, permanent wiring system, or an equipment grounding conductor must be run with the circuit conductors and connected to the equipment-grounding terminal or lead on the appliance.

INSTALLATION INSTRUCTIONS

Before You Start

⚠ WARNING

Excessive Weight Hazard

Use two or more people to move and install washer.
Failure to do so can result in back or other injury.

- To avoid floor damage, set the washer onto cardboard before moving across floor.
- Move the washer to within approximately 3 ft (90 cm) of its final location.

Remove Shipping Strap

Removing the shipping strap is necessary for smooth operation. If the shipping strap is not removed, the washer will make excessive noise. The washer must be in the upright position before removing the shipping strap.

1. Do not cut yellow strap. Pull yellow strap firmly, until completely removed from washer. There will be two cotter pins on the end of the shipping strap when it is pulled out of the washer. The electrical plug is attached to this shipping strap.

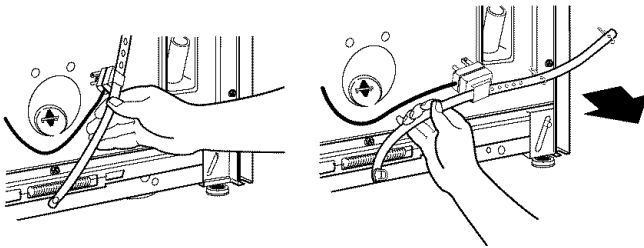

2. Pull firmly to remove the end of the shipping strap that remains pinned to the back of the washer. This will release the rear self-leveling feet.

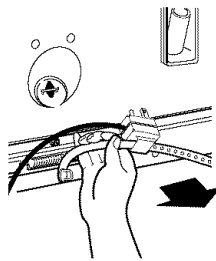

3. Cut the shipping strap about 16" (41 cm) from plug end. Look for the words "CUT HERE." Discard end with the cotter pins. Slide remainder of shipping strap from the power cord. You will use the remainder of the shipping strap later to secure the drain hose.

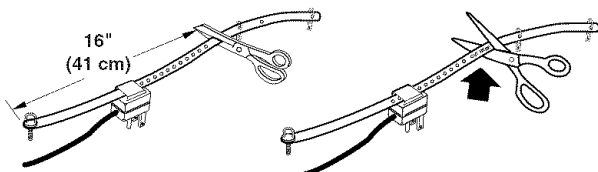

Connect Drain Hose

Proper connection of the drain hose will protect your floors from damage due to water leakage. To keep the drain hose from coming off or leaking, it must be installed according to the following instructions.

IMPORTANT: To ensure proper installation, this procedure must be followed exactly.

1. Check the drain hose to see that it is the proper length.
2. Wet the inside of the straight end of the drain hose with tap water.
IMPORTANT: Do not use any lubricant other than water.
3. Squeeze ears of silver, double-wire clamp with pliers to open. Place clamp over the straight end of the drain hose 1/4" (6 mm) from the end.

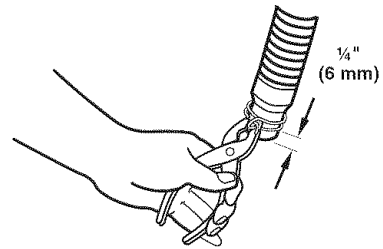

4. Open clamp. Twist hose back and forth while pushing down onto drain connector at the bottom of the washer. Continue until hose contacts the ribbed stop on the cabinet.

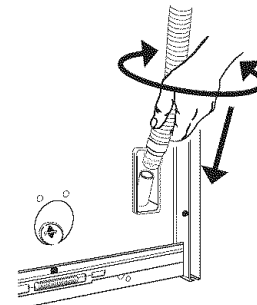

5. Place clamp over area marked "CLAMP." Release clamp.

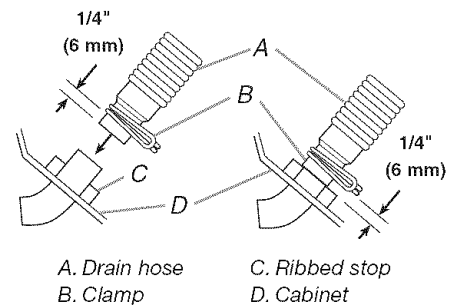

For standpipe or laundry tub drain systems:

1. Open yellow, single-wire clamp with pliers and slide over hooked end of drain hose to secure the rubber and corrugated sections together.

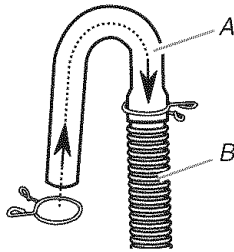

A. Hooked end
B. Drain hose

2. Put hooked end of drain hose into laundry tub or standpipe. Rotate hook to eliminate kinks.

To keep drain water from going back into the washer:

- Do not straighten hooked end of drain hose. Do not force excess drain hose into standpipe. Hose should be secure, but loose enough to provide a gap of air.
- Do not lay excess drain hose in bottom of laundry tub.

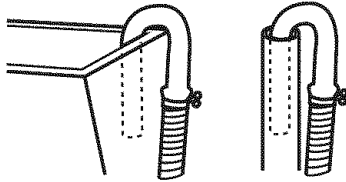

- For floor drain installation, see kit number required under "Tools and Parts."

Connect the Inlet Hoses

The washer must be connected to the water faucets using new inlet hoses (not provided). Do not use old hoses.

Insert new flat washers into each end of the inlet hoses. Firmly seat the washers in the couplings.

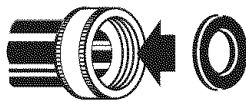

A. Coupling
B. Washer

Connect the inlet hoses to the water faucets

Make sure the washer basket is empty.

1. Attach a hose to the hot water faucet. Screw on coupling by hand until it is seated on the washer.
2. Attach a hose to the cold water faucet. Screw on coupling by hand until it is seated on the washer.

3. Using pliers, tighten the couplings with an additional two-thirds turn.

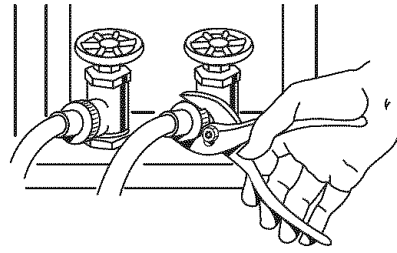

NOTE: Do not overtighten. Damage to the valves can result.

Clear the water lines

4. Run water through both faucets and inlet hoses, into a bucket or laundry tub, to get rid of particles in the water lines that might clog the inlet valve screens.

Connect the inlet hoses to the washer

5. Attach a hose to the HOT water (bottom) inlet valve. Attaching this hose first makes it easier to tighten connection with pliers. Screw on coupling by hand until it is seated on the washer. Using pliers, tighten the couplings with an additional two-thirds turn.

NOTE: Do not overtighten. Damage to the valves can result.

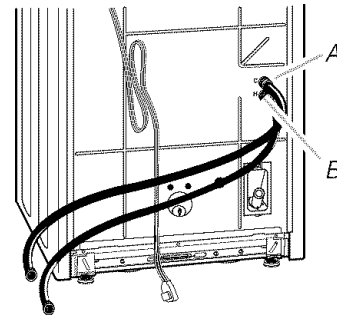

A. Cold water inlet valve
B. Hot water inlet valve

NOTE: The inlet valve may be on the right or the left side of the washer, depending on your model.

6. Attach the hose coming from the cold water faucet, to the COLD water (top) inlet valve. Screw on coupling by hand until it is seated on the washer. Using pliers, tighten the couplings with an additional two-thirds turn.

NOTE: Do not overtighten. Damage to the valves can result.

Check for leaks

7. Turn on the water faucets and check for leaks. A small amount of water might enter the washer. You will drain this later.

NOTE: Replace inlet hoses after 5 years of use to reduce the risk of hose failure. Record hose installation or replacement dates for future reference.

- If you connect only one water hose, you must cap off the remaining water inlet port.
- Periodically inspect and replace hoses if bulges, kinks, cuts, wear, or leaks are found.

Secure the Drain Hose

1. Drape the power cord over the console.
2. Remove any cardboard used to move washer.
3. Locate the remaining portion of shipping strap (not the end with the cotter pins) from Step 3 of "Remove Shipping Strap."

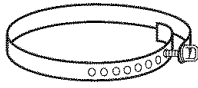

Remaining portion of shipping strap

4. Wrap the drain hose to the laundry tub leg or standpipe with the tie strap. Push fastener into the nearest hole in the shipping strap. (See illustration A or B.)

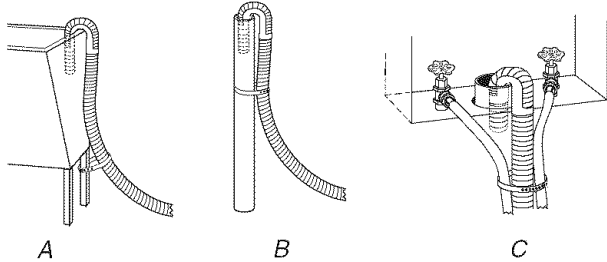

If the washer faucets and the drain standpipe are recessed, put the formed end of the drain hose into the standpipe. Tightly wrap the tie strap around the water inlet hoses and the drain hose. (See illustration C.)

Install Coin Slide Mechanism

NOTE: If the coin slide mechanism has already been installed, skip this step and proceed to "Adjusting Coin Box."

Install Coin Slide

1. Remove the access panel from the top of the meter case by unlocking the service lock with the key shipped inside the parts bag found in the washer basket.
2. Deposit coins in coin slide and push coin slide all the way in. Hold coin slide in extended position and insert through opening in the front of the meter case.
3. From inside the meter case, place the threaded end of the bolt through the center mounting hole in the front of the meter case.
4. While holding the bolt in place, guide the coin slide mechanism onto the threads and into the guide holes in the front of the meter case.
5. Tighten the bolt as you guide the coin slide mechanism into place.
6. Tighten the bolt using a ratchet and a $\frac{5}{16}$ " socket until the slide mechanism is secure and does not move.

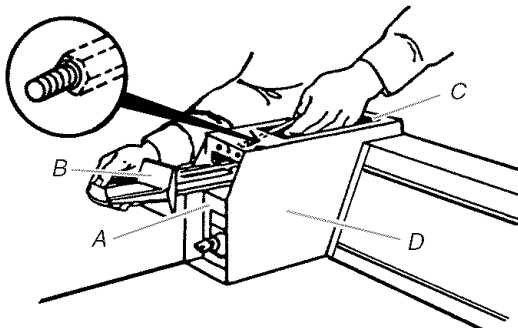

A. Coin box C. Access
B. Coin slide D. Meter case

Adjusting Coin Box

1. Insert the coin box into the meter case from the front. The tight fit of the coin box is set at the factory. You can loosen the fit as desired by loosening the slotted rods inside the front of the coin box.

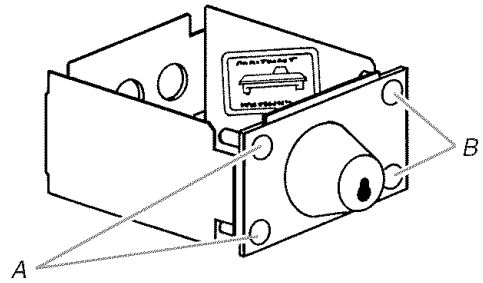

A and B Slotted rods

NOTE: Keep a record of all coin box key numbers. A lost key can only be replaced if ordered by key number from Sears Parts. The key number is located on the key. If the key number is not available, the lock must be drilled out to remove the coin box.

2. Replace the meter case access panel.

Level the Washer

Properly leveling your washer avoids excessive noise and vibration.

Install the front leveling feet

1. Prop up the front of the washer about 4" (10.2 cm) with a wood block or similar object. The block needs to support the weight of the washer.
2. Screw the locknut onto each foot to within 1" (2.5 cm) of the base.

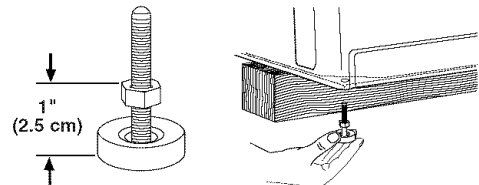

3. Screw the feet into the correct holes at the front corner of the washer until the nuts touch the washer.

NOTE: Do not tighten the nuts until the washer is level.

4. Tilt the washer back and remove the wood block. Gently lower the washer to the floor.
5. Slide the washer to its final location.
6. Tilt the washer forward until the rear of the washer is at least 4" (10.2 cm) off the floor. You may hear the self-adjusting rear feet click into place. Lower the washer to the floor.
7. Check the levelness of the washer by placing a level on the top edges of the washer, first side to side, then front to back.
8. If the washer is not level, move the washer out slightly, tip back, prop up the front of the washer with the wood block and adjust the feet up or down as necessary. Repeat steps 5 through 8 until washer is level.

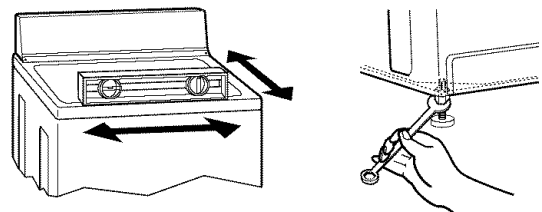

- After the washer is in the final location and level, use a $\frac{1}{16}$ " (14 mm) open-end wrench to turn the nuts on the feet tightly against the washer cabinet.

IMPORTANT: If the nuts are not tight against the washer cabinet, the washer may vibrate.

Complete Installation

- Check the electrical requirements. Be sure that you have the correct electrical supply and the recommended grounding method. See "Electrical Requirements."
- Check that all parts are now installed. If there is an extra part, go back through the steps to see which step was skipped.
- Check that you have all of your tools.
- Check that the yellow shipping strap was removed from the back of the washer and used to secure the drain hose.
- Dispose of/recycle all packaging materials.
- Check that the water faucets are on.
- Check for leaks around faucets and inlet hoses.

⚠ WARNING



Electrical Shock Hazard

Plug into a grounded 3 prong outlet.

Do not remove ground prong.

Do not use an adapter.

Do not use an extension cord.

Failure to follow these instructions can result in death, fire, or electrical shock.

- Plug into a grounded 3 prong outlet.
- Remove the protective film on the console and any tape remaining on the washer.

Making a cycle check

- Read "Washer Use" and run the washer through 1 complete cycle.
- Measure $\frac{1}{2}$ of the normal recommended amount of powdered or liquid detergent and pour it into the washer basket.
- Close the lid.
- The washer may be operated manually. Allow it to complete 1 whole cycle.
- When the cycle is complete, check all hoses and connections for proper operation and that they do not leak.

Testing and adjusting for standard start with coin slide

- Advance timer manually to spin portion of cycle. Allow it to shut off electrically.
- Insert coin(s) and push the coin chute slide all the way in. (Now pull the slide all the way out.) The appliance should start on the return stroke of the coin chute slide.
- If the washer does not start, see the "Adjusting Timer Clutch" section and readjust the clutch.
- After adjustment, retest the coin slide to make sure the coin slide operates correctly.

Adjusting Timer Clutch

All coin operated models have a timer that provides a 9-minute wash in the Normal Cycle. To check the cycle, push the coin slide all the way in and pull all the way out. Note the wash cycle time. If the washer does not start or does not provide the proper wash time, the clutch assembly may need adjustment.

⚠ WARNING



Electrical Shock Hazard

Disconnect power before servicing.

Replace all parts and panels before operating.

Failure to do so can result in death or electrical shock.

NOTE: The washer was tested at the factory. Some time may have been left so that the washer will start to operate before the coin slide is operated. If this happens, take off the access panel from the top of the meter case and set the clutch to OFF position by hand. Then proceed with timer clutch check.

To adjust the clutch:

- Unplug washer or disconnect power.
- Remove the meter case access panel.
- The clutch assembly has a timer clutch adjustment screw. If the washer does not start after the coin slide has been pushed all the way in and out, turn the clutch adjustment screw clockwise (right).
- If the timer goes past the third increment of fill, less than 9 minutes of wash will be provided in the NORMAL Cycle. Turn the clutch adjustment screw counterclockwise (left).

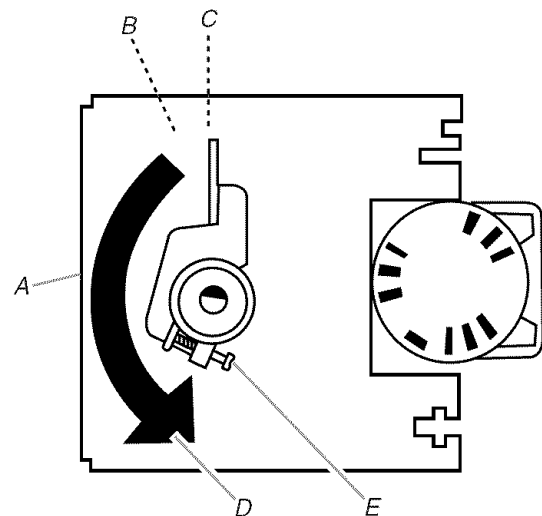

A. Timer front
B. Start
C. Off

D. Rotate counterclockwise
E. Timer clutch adjustment screw

Washer Cabinet

⚠ WARNING



Electrical Shock Hazard

Disconnect power before servicing.

Replace all parts and panels before operating.

Failure to do so can result in death or electrical shock.

Removing Cabinet

1. Unplug washer or disconnect power.
2. Remove 2 screws on console at left and right side on bottom.

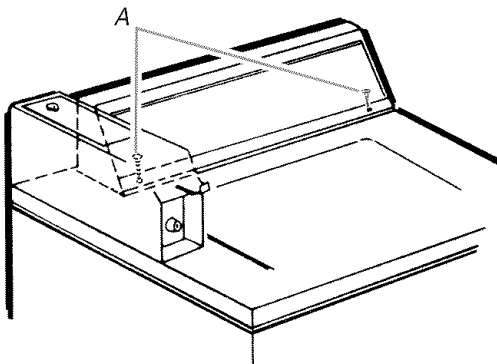

A. Screws

3. Pull console forward then tilt it back.
4. Remove washer cabinet clip on right side under console. Use screwdriver blade as shown.

NOTE: For additional security, top can be locked to washer with a lock and key in the hole provided. Screw type lock available from industry sources.

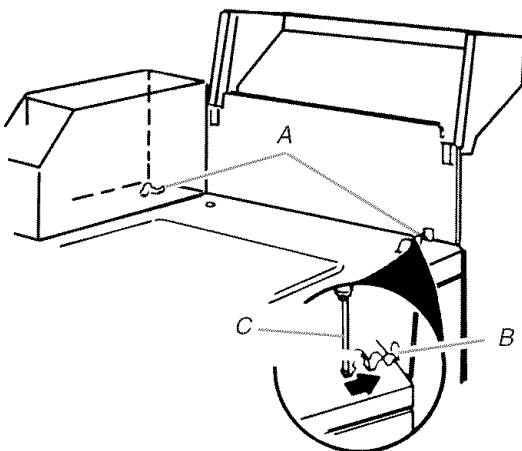

A. Clips
B. Clip

C. Screwdriver blade

5. Open top access panel in meter case. Loosen timer bolts with Phillips screwdriver and lift timer out of the way.

NOTE: You do not have to disconnect the timer.

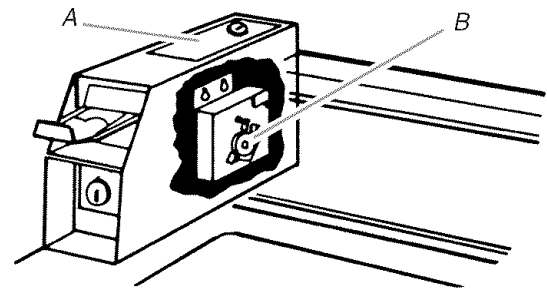

A. Access panel B. Clip

6. Remove washer cabinet clip inside meter case, using screwdriver.
7. Pull cabinet up and forward to remove.

Replacing Cabinet

1. Put cabinet in place on washer.
2. Replace clips at top rear of washer cabinet.
3. Put timer back in place in meter case and tighten timer bolts.
4. Replace meter case access panel.
5. Swing console down into place, push toward rear.
6. Replace 2 console screws.
7. Plug in washer or reconnect power.

Changing Vend Price

NOTE: Place all screws and other items removed from coin slide assembly on a cloth so they will not get lost.

⚠ WARNING



Electrical Shock Hazard

Disconnect power before servicing.

Replace all parts and panels before operating.

Failure to do so can result in death or electrical shock.

1. Unplug washer or disconnect power.
2. Remove slide mechanism from meter case.

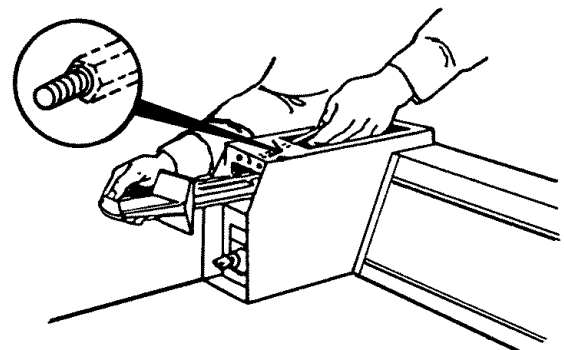

3. Remove slide return spring.
4. Place coin(s) in coin slot(s) and push forward all the way.
5. Remove buffer.
6. Turn coin chute upside down and install or remove required number of block-out keys. Remove keys to increase vend, add keys to lower vend.
7. Reassemble buffer.
8. Pull slide back to original position and reassemble slide return spring.
9. Set new vend price by adding or removing the appropriate block-out keys and/or dime inserts according to Table of Vend Prices.

TABLE OF VEND PRICE

VEND PRICE	COIN SLOTS							
	1	2	3	4	5	6	7	8
0	█	█	█	█	█	█	█	█
10¢	□	█	█	█	█	█	█	█
25¢	█	□	█	█	█	█	█	█
35¢	□	□	█	█	█	█	█	█
50¢	█	█	□	█	█	█	█	█
60¢	□	□	□	█	█	█	█	█
75¢	█	█	□	□	█	█	█	█
85¢	□	□	□	□	█	█	█	█
\$1.00	█	█	□	□	□	█	█	█
\$1.10	□	□	□	□	□	█	█	█
\$1.25	█	█	□	□	□	□	█	█
\$1.35	□	□	□	□	□	□	█	█
\$1.50	█	█	□	□	□	□	□	█
\$1.60	□	□	□	□	□	□	□	█
\$1.75	█	█	□	□	□	□	□	□
\$1.85	□	□	□	□	□	□	□	□
\$2.00	█	█	□	□	□	□	□	□

NOTES:

- Black slots are closed off by block-out key. To remove block-out keys, pull straight up.
- Be sure block-out keys and/or dime inserts are seated properly and ratchet dog is in place with its spring connected. Be sure the proper coin sizing block is in place.
Part # 20-3007 for up to 7 quarters and 1 dime
Part # 20-3006 for up to 8 quarters and 0 dimes
- Unless otherwise ordered, all coin chutes are supplied with Part 20-3006 in place.

10. Plug in washer or reconnect power.

NOTE: Refer to the product information sheet provided with the coin box for additional information.

WASHER USE

⚠ WARNING



Fire Hazard

Never place items in the washer that are dampened with gasoline or other flammable fluids.

No washer can completely remove oil.

Do not dry anything that has ever had any type of oil on it (including cooking oils).

Doing so can result in death, explosion, or fire.

IMPORTANT:

- Be sure your washer is installed as recommended in the "Installation Instructions."
- Occasionally check the drain area to be sure lint is not clogging the drain.

Cycle Time

The cycle time is 19½ minutes plus the fill times for each wash cycle.

Two-Speed Models

Settings	Water Temp.		Speeds	
	Wash	Rinse	Agitate	Spin
Cotton/Sturdy	Hot	Cold	Fast	Fast
Permanent Press	Warm	Cold	Fast	Fast
Permanent	Cold	Cold	Fast	Fast
Delicate	Warm	Cold	Slow	Fast
Knit	Warm	Cold	Slow	Fast

Cycle Time = 19½ Minutes + Fill

One-Speed Models

Settings	Water Temp.		Speeds	
	Wash	Rinse	Agitate	Spin
Cotton/Sturdy	Hot	Cold	Fast	Fast
Permanent Press	Warm	Cold	Fast	Fast
Permanent	Cold	Cold	Fast	Fast

Cycle Time = 19½ Minutes + Fill

Typical Full Load Chart

Load Type	Loading Suggestion	Load Type	Loading Suggestion
Mixed Load	2 double or 1 king size sheet 4 pillowcases 6 T-shirts 6 pair shorts 2 boy's shirts 2 blouses 6 handkerchiefs	Heavy Work Clothes	2 pair work pants 3 work shirts 1 coverall 3 pair jeans

WASHER CARE

LUBRICATING

Every Kenmore Automatic Washer is thoroughly lubricated at the time of assembly and should not require further lubrication under normal operating conditions. In exceptional cases where lubrication is required, the following guide is provided.

Component	Lubricant	Application Instructions
Gearcase	SAE60 Non-Detergent, Non-Foaming Motor Oil	Replace with 15 oz (444 mL) of oil whenever gearcase is repaired. One pint (473.2 mL) cans are available as Part Number 350572.
Lower Centerpost Bearing	Turbine Oil	Use ¼ oz (7.4 mL) of turbine oil (available in pint cans), in the lower centerpost bearing before installing the gearcase and superstructure.
Rear Leveling Link Mechanism	Lubriplate 630-2	Rub lightly on moving parts as required.
Agitator Shaft & Upper Centerpost Bearings	Turbine Oil	Upon repair or inspection, fill cavity above centerpost bearings with turbine oil.

NOTES:

- Shut off hot and cold water outlets when washer is not in use.
- Drain machine to avoid damage if washer will be subjected to freezing temperatures.

Be sure the open end of the drain hose does not fall or drop down lower than the water level in the machine. Water will siphon out of washer if this happens.

Before Transporting Washer to a New Location

1. Unplug washer or disconnect power.
2. Coil power cord and tape to rear of washer.
3. Remove inlet hoses from faucets. Push them into washer. Do not kink.
4. Remove wire form and push drain hose into washer. Do not kink.
5. Tape lid closed.
6. Prop washer up about 4" (10.2 cm) on one or two corner posts from shipping carton, remove spacers, and turn front feet in flush with cabinet.
7. Push rear leveling legs up and tape securely.
8. Stuff a blanket between top of basket and washer lid except in area of lid switch.
9. Washer is ready for shipping.

NOTE: When washer is reinstalled, use new hoses.

If you need an additional parts list, contact your local Sears store or Sears Service Center. Make sure to furnish the complete model number when ordering.

TROUBLESHOOTING

First try the solutions suggested here and possibly avoid the cost of a service call...

NOTE: Washer will not operate with the lid open.

Washer and Components

Noisy

- **Is the load balanced, and is the washer level?** The wash load should be balanced and not overloaded. The washer must be level. The front feet should be properly installed and the nuts tightened. Reset the rear leveling legs (if needed). See the Installation Instructions.
- **Did you completely remove the yellow shipping strap with cotter pins?** See the Installation Instructions.
- **Are the gears engaging after the drain and before spin, or is the upper part of agitator clicking during wash?** These are normal washer noises.

Leaking

- **Check the following:**
 - Are the fill hoses tight?
 - Are the fill hose washers properly seated?
 - Is the drain hose clamp properly installed? See the Installation Instructions.
- **Is the sink or drain clogged?** Sink and standpipe must be able to handle 17 gal. (64 L) of water per minute.

- **Is water deflecting off the tub ring or the load?** Center the tub before starting the washer. The wash load should be balanced and not overloaded. The fill or spray rinses can deflect off the load. The washer must be level. The front feet should be properly installed and the nuts tightened. Reset the rear leveling legs (if needed). See the Installation Instructions.
- **Check household plumbing for leaks.**

Basket crooked

- **Was the washer basket pulled forward during loading?** Push the basket to the center before starting wash.
- **Is the load balanced, and is the washer level?** The wash load should be balanced and not overloaded. The washer must be level. The front feet should be properly installed and the nuts tightened. Reset the rear leveling legs (if needed). See the Installation Instructions.
- **The washer basket moves while washing.** This is normal.

Agitator operation

- **The top of the agitator is loose, or moves in only one direction.** This is normal.

NEW VEND PRICE

Order Form

To change vend price, detach and mail the lower portion to:

**Customer Service Department
Greenwald Industries Inc.
212 Middlesex Ave.
Chester, CT 06412**

The coin chute has been preset at the factory.

When increasing in \$.25 pricing

Follow product information instructions; no extra parts required.

When decreasing in \$.25 pricing - or - changing to \$.10 pricing

(Coin sizing block required; see "Changing Vend Price" section.)

Order required parts using this tear-off. Block-out keys will be shipped to you at no charge. Follow product information instructions.

Quantity _____

Existing Vend Price _____

New Vend Price _____

Name _____

Company _____

Address _____

City _____

Daytime phone _____

Purchase date _____

Washer Operation

Washer stops, won't fill, rinse or agitate

⚠ WARNING



Electrical Shock Hazard

Plug into a grounded (earthed) outlet.

Do not remove ground prong.

Do not use an adapter.

Do not use an extension cord.

Failure to follow these instructions can result in death, fire, or electrical shock.

■ Check the following:

Is the power cord plugged into a grounded 3 prong outlet?

Is the indicator on the Cycle Control knob properly lined up with a cycle? Turn the Cycle Control knob to the right slightly and pull to start.

Are both the hot and cold water faucets turned on?

Is the water inlet hose kinked?

- **Are the water inlet valve screens clogged?** Turn off the water and remove inlet hoses from the washer. Remove any accumulated film or particles. Reinstall hoses, turn on water and check for leaks.
- **Is the lid open?** The lid must be closed during operation. Washer will not agitate or spin with the lid open.

- **Does the water level seem too low, or does the washer appear to not fill completely?** The top of the agitator is much higher than the highest water level. This is normal and necessary for clothes to move freely.
- **Has a household fuse blown, or has a circuit breaker tripped?** Replace the fuse or reset the circuit breaker. If the problem continues, call an electrician.
- **Are you using an extension cord?** Do not use an extension cord.
- **Is the washer overloaded?** Wash smaller loads.

Washer won't drain or spin

- **Is the drain hose clogged, or the end of the drain hose more than 96" (244 cm) above the floor?** See the Installation Instructions for proper installation of drain hose.
- **Is the lid open?** The lid must be closed to operate.
- **Is there excessive sudsing?** Always measure detergent. Follow manufacturer's directions.

Washer continues to fill or drain, cycle seems stuck

- **Is the top of drain hose lower than the water level in washer?** The top of the hose must be higher than the water level in the washer for proper operation. See the Installation Instructions.
- **Does the drain hose fit too tightly in the standpipe, or is it taped to the standpipe?** The drain hose should be loose yet fit securely. Do not seal the drain hose with tape. The hose needs an air gap. See the Installation Instructions.

Wash temperature not what I selected

- **Are the hot and cold water inlet hoses reversed?** See the Installation Instructions for more information. As your frequency of loads washed increases, the water temperature may decrease for hot and warm temperature selections. This is normal.

New Vend Price Order Form on Page 13

Washer Results

Load too wet

- **Did you use the right cycle for the load being washed?** Select a cycle with a higher spin speed (if available).
- **Did you use a cold rinse?** Cold rinses leave loads wetter than warm rinses. This is normal.

Residue or lint on load

- **Did you sort properly?** Sort lint givers (towels, chenille) from lint takers (corduroy, synthetics). Also sort by color.
- **Did you overload the washer?** The wash load must be balanced and not overloaded. Clothes should move freely. Lint can be trapped in the load if overloaded. Wash smaller loads.
- **Did you select the correct water level?** The water level should be correct for the load size. Clothes should move freely in the water.
- **Did you use enough detergent?** Follow manufacturer's directions. Use enough detergent to hold the lint in the water.
- **Did you line dry your clothing?** If so, you can expect some lint on the clothing.
- **Check the following:**
 - Was paper or tissue left in the pockets?
 - Is your water colder than 60°F (15.6°C)? Wash water colder than 60°F (15.6°C) may not completely dissolve the detergent.
 - Did you use the proper cycle time for the load? Reducing wash time (duration) is another way to reduce lint.

Stains on load

- **Did you follow the manufacturer's directions when adding detergent and fabric softener?** Measure detergent and fabric softener. Use enough detergent to remove soil and hold it in suspension. Dilute fabric softener and add to the rinse portion of a cycle only. Do not drip fabric softener on clothes.
- **Is there above average iron (rust) in water?** You may need to install an iron filter.
- **Did you properly sort the load?** Sort dark clothes from whites and lights.
- **Did you unload the washer promptly?** To avoid dye transfer, unload the washer as soon as it stops.

Load is wrinkled

- **Did you unload the washer promptly?** Unload the washer as soon as it stops.
- **Did you use the right cycle for the load being washed?** Use the cycle for Casual or Permanent Press clothes or another cycle with low spin speeds (if available) to reduce wrinkling.
- **Did you overload the washer?** The wash load must be balanced and not overloaded. Loads should move freely during washing.

- **Was the wash water warm enough to relax wrinkles, or are you using warm rinses?** If safe for the load, use warm or hot wash water. Use cold rinse water.
- **Are the hot and cold water hoses reversed?** Check that the hot and cold water hoses are connected to the right faucets. See the Installation Instructions.

Load is tangled or twisted

- **Did you overload the washer?** The wash load must be balanced and not overloaded. Loads should move freely during washing.
- **Did you wrap items around the agitator?** Drop items loosely into the washer. Do not wrap items around the agitator.

Gray whites, dingy colors

- **Did you properly sort the load?** Dye transfer can occur when mixing whites and colors in a load. Sort dark clothes from whites and lights.
- **Was the wash temperature too low?** Use hot or warm washes if safe for the load. Make sure your hot water system is adequate to provide a hot water wash.
- **Did you use enough detergent, or do you have hard water?** Use more detergent for washing heavy soils in cold or hard water.
- **Are the hot and cold water hoses reversed?** Check that the hot and cold water hoses are connected to the right faucets. See the Installation Instructions.

Garments damaged

- **Check the following:**
 - Were sharp items removed from pockets before washing? Empty pockets, zip zippers, snap or hook fasteners before washing.
 - Were strings and sashes tied to avoid tangling?
 - Were items damaged before washing? Mend rips and broken threads in seams before washing.
- **Did you overload the washer?** The wash load must be balanced and not overloaded. Loads should move freely during washing.
- **Did you add chlorine bleach properly?** Do not pour chlorine bleach directly onto load. Wipe up bleach spills. Undiluted bleach will damage fabrics. Do not place load items on top of the bleach dispenser when loading and unloading the washer (on some models).
- **Did you follow the manufacturer's care label instructions?**

Get it fixed, at your home or ours!

Your Home

For repair – **in your home** – of **all** major brand appliances, lawn and garden equipment, or heating and cooling systems, **no matter who made it, no matter who sold it!**

For the replacement parts, accessories and owner's manuals that you need to do-it-yourself.

For Sears professional installation of home appliances and items like garage door openers and water heaters.

1-800-4-MY-HOME[®] (1-800-469-4663)

Call anytime, day or night (U.S.A. and Canada)

www.sears.com www.sears.ca

Our Home

For repair of carry-in items like vacuums, lawn equipment, and electronics, call or go on-line for the location of your nearest **Sears Parts & Repair Center.**

1-800-488-1222

Call anytime, day or night (U.S.A. only)

www.sears.com

To purchase a protection agreement (U.S.A.) or maintenance agreement (Canada) on a product serviced by Sears:

1-800-827-6655 (U.S.A.)

1-800-361-6665 (Canada)

Para pedir servicio de reparación a domicilio, y para ordenar piezas:

1-888-SU-HOGAR[®]

(1-888-784-6427)

Au Canada pour service en français:

1-800-LE-FOYER^{MC}

(1-800-533-6937)

www.sears.ca

The Sears logo is centered at the bottom of the page. It features the word "Sears" in a bold, serif font. A horizontal line is positioned below the letters "e" and "a".