



swisherinc.com

OWNER'S MANUAL

MODEL NO.
ZT1436B
ZT18542
ZT2250



IMPORTANT
Read and follow all
Safety Precautions
and Instructions
before operating this
equipment.

Rev. 06-039

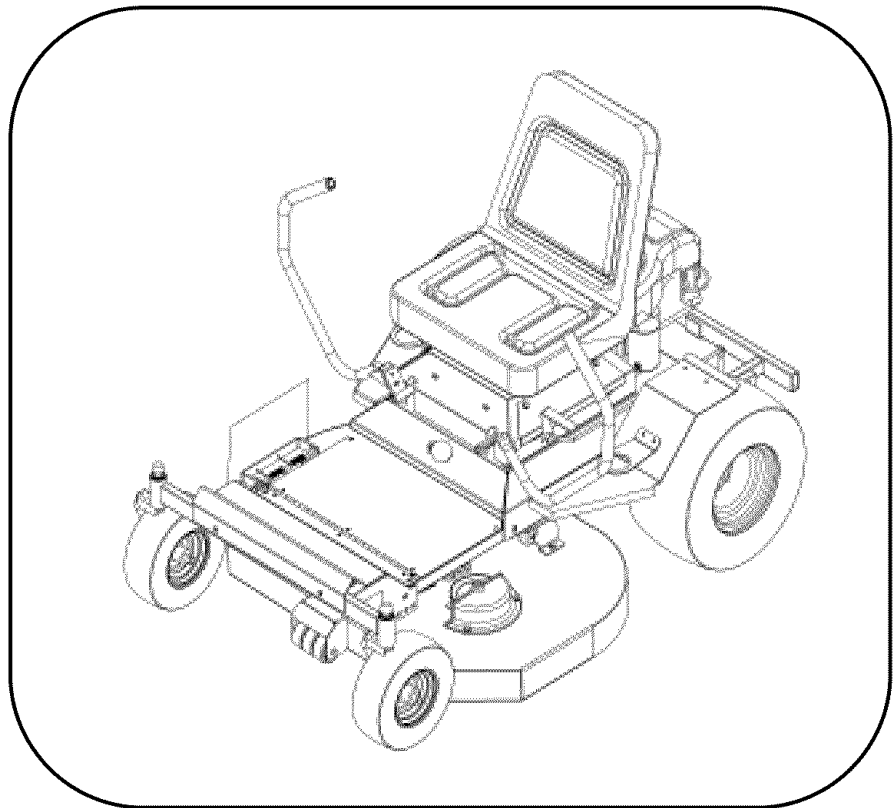

"Z" SERIES **ZERO TURN HYDROSTATIC DRIVE**

Assembly
Operation
Service and Adjustment
Repair Parts

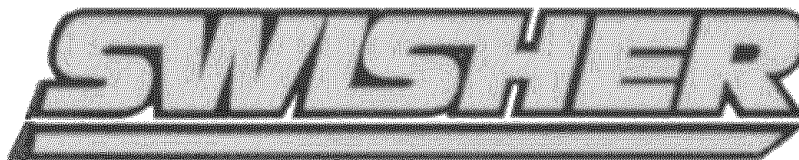

1602 CORPORATE DRIVE, P.O. BOX 67, WARRENSBURG, MISSOURI 64093
PHONE 660-747-8183 FAX 660-747-8650

Manufacturing quality lawn care equipment since 1945

Made In The

USA

LIMITED WARRANTY

The manufacturer's warranty to the original consumer purchaser is: This product is free from defects in materials and workmanship for a period of two (2) years from the date of purchase by the original consumer purchaser. We will repair or replace, at our discretion, parts found to be defective due to materials or workmanship. This warranty is subject to the following limitations and exclusions:

- 1) Engine Warranty All engines utilized on our products have a separate warranty extended to them by the individual engine manufacturer. Any engine service difficulty is the responsibility of the engine manufacturer and in no way is Swisher Mower Co., Inc. or its agents responsible for the engine warranty. The Briggs & Stratton Engine Service Hot-Line is 1-800-233-3723. The Tecumseh Engine Service Hot-Line is 1-800-558-5402.

- 2) Commercial Use This product is not intended for commercial use and carries no commercial warranty.

- 3) Limitation This warranty applies only to products which have been properly assembled, adjusted, and operated in accordance with the instructions contained within this manual. This warranty does not apply to any product of Swisher Mower Co., Inc., that has been subject to alteration, misuse, abuse, improper assembly or installation, shipping damage, or to normal wear of the product.

- 4) Exclusions Excluded from this warranty are normal wear, normal adjustments, and normal maintenance.

In the event you have a claim under this warranty, you must return the product to an authorized service dealer. All transportation charges, damage, or loss incurred during transportation of parts submitted for replacement or repair under this warranty shall be borne by the purchaser. Should you have any questions concerning this warranty, please contact us toll-free at 1-800-222-8183. The model number, serial number, date of purchase, and the name of the authorized Swisher dealer from whom you purchased the mower will be needed before any warranty claim can be processed.

THIS WARRANTY DOES NOT APPLY TO ANY INCIDENTAL OR CONSEQUENTIAL DAMAGES AND ANY IMPLIED WARRANTIES ARE LIMITED TO THE SAME TIME PERIODS STATED HEREIN FOR ALL EXPRESSED WARRANTIES. Some states do not allow the limitation of consequential damages or limitations on how long an implied warranty may last, so the above limitations or exclusions may not apply to you. This warranty gives you specific legal rights and you may have other rights, which vary from state-to-state. This is a limited warranty as defined by the Magnuson-Moss Act of 1975.

TABLE OF CONTENTS

WARRANTY.....	2	SERVICE / ADJUSTMENT.....	11-14
INTRODUCTION.....	3	WIRING DIAGRAM	15
SAFETY.....	3-6	PARTS BREAKDOWN.....	16-28
ASSEMBLY/OPERATION.....	7-8	TROUBLESHOOTING.....	29
MAINTENANCE.....	9-10	SLOPE GUIDE.....	30

Thank you for choosing Swisher's Zero Turn Rider Mower. Before operating your mower, please read, understand and follow all of the safety precautions and other instructions explained in this manual . As with all power equipment, lawnmowers can be potentially dangerous if improperly used.

SAFETY PRECAUTIONS & DECALS



This Safety Alert Symbol indicates important messages in this manual. When you see this symbol, carefully read the message that follows and be alert to the possibility of personal injury.

Read this manual completely. This machine can amputate hands and feet, and throw objects. Failure to observe the following safety instructions could result in serious injury or death.

- Read the manual. Learn to operate this machine safely.
- Always disconnect the spark plug wire and place the wire where it cannot contact the spark plug, to prevent accidental starting the engine when setting up, transporting, adjusting or making repairs.
- Keep all shields and guards in place.
- Understand the speed, steering and stability of this machine. Know the positions and operations of all controls before you operate this machine. Check all of the controls in a safe area before starting to work with this machine.
- Allow only responsible adults who are familiar with these instructions to operate this machine. **Never allow children to operate this machine.**
- Clear the area of objects such as rocks, toys, wire, etc. that can be picked up and thrown by the blade.
- Be sure the area is clear of other people before mowing. Be aware of the mower discharge direction and do not point at anyone. **Stop the machine** if anyone enters the mowing area. Children are often attracted to the machine and the mowing activity. *Never assume that children will remain where you last saw them.* Keep children under the watchful care of another responsible adult.
- **No riders!**
- Do not put hands or feet near or under rotating parts. Keep clear of the discharge opening at all times.
- Do not mow in reverse. **Always look down and behind before and during backing.**



The operation of any cutter can encounter foreign objects to be thrown into the eyes, resulting in severe eye damage. Always wear certified safety glasses or wide-vision safety goggles for over spectacles before starting any cutting machine and while operating such a machine.



The operation of any cutter produces sound waves that are damaging to the human ear. Ear protection is recommended.



CAUTION!

Tragic accidents can occur if the operator is not alert to the presence of children. Children are often attracted to the machine and the mowing activity. *Never assume that children will remain where you last saw them.*



SLOPE OPERATION! (See page 27)

Do not operate on slopes greater than 15 degrees.
Use extra caution when mowing on slopes. Operate self-propelled units up and down slopes. There is a significant risk of overturns when operating across slopes. If you feel uneasy on a slope then **do not** mow it.

- Turn off the blades when not mowing. Before leaving the machine, turn off the blades and stop the engine.
- Watch for traffic when operating near or crossing roadways.
- Do not operate the mower if it has been dropped or damaged in any manner or if the mower vibrates excessively. Excessive vibration is an indication of damage. Repair mower as necessary.
- Dress properly. Do not operate the mower when barefoot or wearing open sandals. Wear only solid shoes with good traction when mowing.
- Never allow operation by untrained persons.
- Do not operate the machine while under the influence of alcohol or drugs.
- Operate self-propelled machines up and down slopes. There is significant risk of overturns when operating across slopes. Avoid sudden turns. Operate walk-behind machines across slopes. There is a significant risk of slipping under a walk-behind machine when operating up and down slopes.
- Never tamper with safety devices. Check their proper operation regularly.
- Stop and inspect the equipment if you strike an object. Repair, if necessary, before restarting. Never make adjustments or repairs with the engine running. Mower blades are sharp and can cut. Wrap the blades or wear gloves, and use extra caution when servicing them. Do not operate at too fast a rate.
- Do not mow close to ditches, embankments or drop-offs. An edge could collapse. A mower wheel over the edge could suddenly turn the unit over.
- Do not mow on wet grass if possible. Wet grass causes reduced traction and could cause sliding. Do not park on a slope unless absolutely necessary.
- Always chock or block wheels and set parking brake if parked on slope.

- Turn off the blades when not mowing. Before leaving the machine, turn off the blades and stop the engine.
- Watch for traffic when operating near or crossing roadways.
- Do not operate the mower if it has been dropped or damaged in any manner or if the mower vibrates excessively. Excessive vibration is an indication of damage. Repair mower as necessary.
- Dress properly. Do not operate the mower when barefoot or wearing open sandals. Wear only solid shoes with good traction when mowing.
- Never allow operation by untrained persons.
- Do not operate the machine while under the influence of alcohol or drugs.
- Operate self-propelled machines up and down slopes. There is significant risk of overturns when operating across slopes. Avoid sudden turns. Operate walk-behind machines across slopes. There is a significant risk of slipping under a walk-behind machine when operating up and down slopes.
- Never tamper with safety devices. Check their proper operation regularly.
- Stop and inspect the equipment if you strike an object. Repair, if necessary, before restarting. Never make adjustments or repairs with the engine running. Mower blades are sharp and can cut. Wrap the blades or wear gloves, and use extra caution when servicing them. Do not operate at too fast a rate.
- Do not mow close to ditches, embankments or drop-offs. An edge could collapse. A mower wheel over the edge could suddenly turn the unit over.
- Do not mow on wet grass if possible. Wet grass causes reduced traction and could cause sliding. Do not park on a slope unless absolutely necessary.
- Always chock or block wheels and set parking brake if parked on slope.



WARNING: Hydraulic fluid can cause severe burns and penetrate skin causing severe injury or death.

- Do not step on mower deck when operating, dismounting or mounting the mower.
- Never push or pull unit with another vehicle. Transmission damage will occur.
- When transporting be sure to secure mower frame to transport vehicle. NEVER tie down to moving parts or linkages which may become damaged or come loose.
- NEVER transport mower while engine is running.
- NEVER add fuel or remove gas cap while engine is running or hot.
- NEVER store unit near an open flame such as a water heater or furnace.
- NEVER modify or allow anyone to modify or alter any components or safety devices.
- ALWAYS keep mower clean and free of debris and grass clippings.
- NEVER reverse battery cables. Electric shock will occur.
- ALWAYS keep battery away from open flame and sparks. Explosive gases from battery can cause serious injury or death.
- ALWAYS wear safety glasses and protective gear when servicing the battery. Battery fluid contains sulfuric acid. Contact with battery acid on skin or clothing can cause severe chemical burns.
- NEVER tip battery beyond a 45 degree angle in any direction.

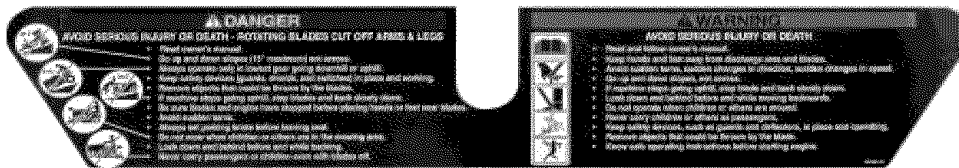

Danger/Warning Decal – OD99155



Ignition/PTO/Throttle Decal – OD99154

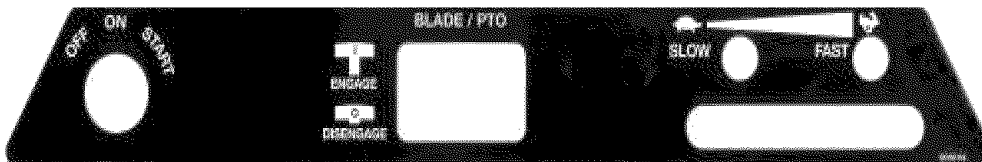

Ignition/PTO/Throttle Decal 50" Mower Only – OD99157



Swisher Flag U.S.A.– OD39



Triangle Danger Decal – OD55



Notice Do Not Alter Wiring Decal– OD74

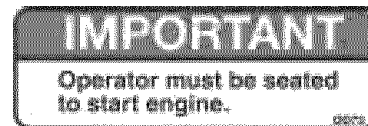

Operator Must Be Seated Decal– OD73

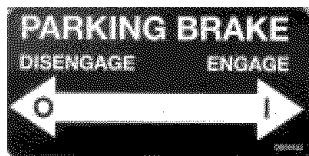

Parking Brake Decal – OD99152

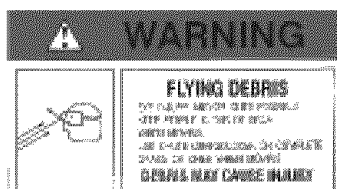

Flying Debris Decal – OD43



No Step Decal – OD11

DECALS NOT SHOWN

Z 14.5/36" Decal- OD112

36" Deck White Decal- OD99159

Swisher Z 14.5/36" Decal- OD108

Z 18.5/42" Decal - OD122

42" Deck White Decal- OD99126

Swisher Z 18.5/42" Decal-Right– OD120

Height of Cut Decal - OD99153

Height Indicator Decal - OD99151

Swisher Z 18.5/42" Decal-Left- OD124

Z 22.0/50" Decal- OD123

50" Deck White Decal- OD99160

Swisher Z 22.0/50" Decal- Right- OD121

Swisher Z 22.0/50" Decal- Left- OD125

Small Logo White Decal- OD99156

Swisher Patent Decal– OD88

UNCRATING/ASSEMBLY

- Dispose of top and side panels of the crate.
- Remove loose parts and packing material.
- Cut any banding or strapping that may be holding the mower to the crate.
- Disengage spark plug wire and place where it cannot make a connection.
- Assemble the seat and clip wiring harness into the bottom of seat.
NOTICE: Mower will not start unless the seat is connected to the wiring harness.
- Raise mower deck to its highest position by turning the handle clockwise.
- Set parking brake to Disengage.
- Open transmission valves from behind by pushing-IN on each of the levers until they stop; rotate them to the locked (left) position. (See Page 14)
- Carefully push the mower off the crate to a safe and level area.
- Check engine oil. All engines are filled with oil and tested at the factory. Verify oil level and add if necessary before starting engine. (See Engine Owner's Manual)
- Check the battery. If battery is put into service after the "month & year" of the date on the battery, then it may need to be charged with a 12 volt battery charger for a minimum of 1 hour, but no more than 2 hours at a rate of 6 to 10 amps.
- Attach battery cable(s) to battery.
- Install steering levers. Align steering lever with holes in steering linkage on mower. Keep levers aligned with each other.
- Reconnect spark plug wire.

OPERATING YOUR NEW ZERO TURN RIDER MOWER

CONTROLS

- **OPERATOR PRESENCE SYSTEM:** This mower is equipped with an operator's presence system. Any attempt to leave the seated position with the engine running, without first disengaging the PTO switch will cause the engine to shut off. Never get off the mower without placing the steering levers in the neutral position.



WARNING: Do not operate the machine unless the **Operator's Presence System** is functioning as described.

- **PARKING BRAKE:** Always set the parking brake before starting. The parking brake is located on the drivers left hand side. Engage the parking brake by pushing the lever rearward and down until lever locks into position. Be sure to release parking brake before operating the machine.
- **IGNITION:** The ignition switch is located on the drivers right hand side toward the rear of the seat. The ignition switch has three positions: OFF, ON, START.
- **THROTTLE:** The throttle/choke control is located on the drivers right hand side towards the front of the seat. For maximum performance and battery charging, operate mower at full throttle. When starting a cold engine, place lever forward in the full choke position. After start up, move throttle rearward to full throttle position. Move lever all the way to the rear for lowest setting before shutting off engine. The 50" Model has a push/pull choke mounted on the right side fender for easier cold weather starts. Pull out to choke (start) engine.
- **PTO SWITCH:** The PTO, or Power Take Off switch is used to engage the blades of the mower. When the PTO switch is pulled out the blades will be engaged. When the PTO switch is pushed in the blades will be disengaged. The PTO switch must be pushed in to complete the Operator's Presence System to start engine.
- **NEUTRAL LOCK:** The steering levers must be in the **outward and locked** position for the mower to start. (See page 11)

MOWING



WARNING: Do not operate mower at too fast of a rate. Sudden movements forward and backward at fast speeds can cause accidents resulting in personal injury.

- Start out moving steering levers **SLOWLY** forward and backward until you learn to operate the unit. **NOTE:** This mower has been designed to be very maneuverable. Practice in open, flat areas is extremely necessary to become comfortable and efficient with the controls.
- **BEGIN TO MOW:** Before starting the engine, set the desired deck height.
- Start the mower engine.
- Position the throttle lever about halfway and engage PTO switch. Reposition throttle lever to full throttle position.
- Move steering levers forward to begin mowing.



CAUTION: Always make sure the deck is not plugged with grass or other debris. Failure to do this will cause damage to the PTO belt.

- **STOPPING:** Hydrostatic mowers use hydrostatic braking through the transmissions. To slow or stop the unit move the steering levers to the neutral position
- **STOPPING THE ENGINE:** Move the throttle lever to slow position, allow engine to idle for 30 seconds and turn ignition to off position. **CAUTION:** Failure to position the ignition key to any position except off will cause discharge of the battery.

STARTING MOWER

- **TO START:** Position steering handles outward to neutral locked position. Engage parking brake. Extend throttle to full choke position. Start ignition and slide throttle lever back to full throttle position. Allow engine to warm up for 1 minute. Release parking brake. Model ZT2250 has a remote choke assembly located on the right fender, behind the rider.
- **FORWARD MOVEMENT:** Position steering handles inward to the drive position. To move the mower forward gently push both steering levers forward equal distance from the neutral position. The further you move the levers forward the faster you will travel. **CAUTION** steering levers have quick response timing.
- **BACKWARD MOVEMENT:** To move the mower backwards, gently pull back on the steering levers the same distance from neutral. The further you pull back the faster you will travel. **NOTE** it is normal for the reverse speed to be less than the forward for easier turning.
- **TURNS:** For left turn, move the right lever farther forward than the left. For right turn, move the left lever farther forward than the right. To obtain a tight turning radius, **GENTLY** reverse one lever and push the other lever forward. **CAUTION:** Aggressive turns can damage lawns. Do not make turns with the inside wheel stopped. It is better to keep both wheels turning slightly.
- **DECK HEIGHT ADJUSTMENT:** To raise the mower deck up and down, simply rotate the lever located in front of the seat above the floor plate. Clockwise raises the deck. Counterclockwise lowers the deck. The deck is adjustable from 1 ½" to 3 ½".
- For best performance, tall grass should be mowed once in the highest position and once again at desired cut height. Never cut more than 1/3 the height in one cutting.
- **ENGAGING BLADES:** Operator must be seated for operation of blades. With engine to full throttle position, pull UP on PTO switch located between the throttle and the key switch. To disengage blades, push DOWN on PTO switch.
- **STOPPING ENGINE:** Place both levers in the outward neutral locked position. Push PTO switch in to disengage. Place throttle lever to lowest setting and let idle for 30 seconds. Turn off ignition key and engage parking brake.

MAINTENANCE SCHEDULE

INSPECT BEFORE EACH USE

- **Loose fasteners:** Be sure all fasteners are at proper torque. Especially guards and blades.
- **Parking brake:** If brake does not keep unit from rolling, brake must be adjusted or repaired.
- **Tires:** Always check and maintain proper tire pressure (See tire sidewall for recommendation). Check for damage due to sharp rocks, objects or stumps.
- **Operator Presence System:** The engine should not start unless the PTO switch is disengaged and the control levers are locked in the neutral position. Any attempt to leave the seated position with the PTO switch engaged will kill the engine.
- **Oil level:** To prevent damage to engine, always check and maintain proper oil level. Never operate engine with the oil level below the add mark on the dipstick. Be sure to tighten the dipstick securely after inspection. Refer to engine manual for additional information.

INSPECT EVERY 8 HOURS

- **Proper cleaning:** Remove any build up of grass, dirt or debris with a brush or cloth from engine, battery, deck and and transaxles. Do not use harsh chemicals or abrasives. Keep all painted surfaces and wheels free of oil and gasoline. Protect all painted surfaces with an automotive wax. Do not spray unit with water or store outdoors unprotected. Water can invade sealed bearings and reduce component life.



Do not spray water onto hydrostatic transmissions. This will cause injection of water into the unit causing failure.

- **Air filter:** The engine will not run properly with a dirty or damaged air filter. Check filter before starting the engine. Check for buildup of dirt or debris. Replace if bent, clogged, or damaged.
- **Oil level:** To prevent damage to engine, always check and maintain proper oil level. Never operate engine with the oil level below the add mark on the dipstick. Be sure to tighten the dipstick securely after inspection.

INSPECT EVERY 25 HOURS

- **Lubrication:** Grease all pivot points with a high temp grease.
- **Battery, check and clean:** Keep battery terminals clean and tight. Periodic charging will extend its life. Clean terminals with a wire brush and coat with a petroleum jelly.
- **Change engine oil and filter:** Use only quality detergent oil. See engine manual for instructions. Select viscosity grade according to your expected environmental temperature.
- **Blades:** Best results will come from sharp blades. Replace if bent, damaged or worn.
- **Engine air screen:** Screen must be clean and free of debris for proper engine cooling. Clean with a brush or cloth. Do not spray with pressurized water.
- **Muffler:** Inspect for damage or corrosion. Keep free of grass or debris to prevent fire.

INSPECT EVERY 100 HOURS

- **Clean engine cooling fins:** Clogged cooling fins can damage engine due to overheating. Keep fins and external surfaces of the engine clean.
- **Replace air filter:** The engine will not run properly with a dirty or damaged air filter. Check filter before starting the engine. Check for buildup of dirt or debris. Replace if bent, clogged, or damaged. See engine manual for detailed instructions.
- **Replace spark plugs:** See engine manual for detailed instructions.

INSPECT EACH SEASON

- **Belts:** Check belts for wear and deterioration. See service and adjustments.
- **Spark plug:** See engine manual for detailed instructions.
- **Replace in-line fuel filter:** Replace every season.

INSPECT BEFORE STORAGE

- **Change engine oil and filter:** See engine manual for detailed instructions.
- **Lubrication:** Grease all pivot points with a high temp grease.
- **Check battery:** Keep battery terminals clean and tight. Periodic charging will extend its life. Clean terminals with a wire brush and coat with a petroleum jelly.
- **Loose fasteners:** Be sure all fasteners are at proper torque, especially guards and blades.

SERVICE / ADJUSTMENTS

⚠ CAUTION: Before performing any service or adjustments do as follows:

1. Turn off PTO switch.
2. Position unit on smooth flat surface.
3. Place steering levers in outward, neutral-locked position.
4. Turn ignition key “OFF” and set parking brake.
5. Wait for all moving parts to stop and disconnect spark plug wire.

TRACKING

Adjustments to the unit may need to be made if the unit does not track in a straight line. The primary reason for the unit not tracking straight is incorrect or unbalanced tire pressure. Before making any adjustments first check and adjust the tire pressure. **DO NOT EXCEED MAXIMUM RECOMMENDED TIRE PRESSURE.**

ADJUST LINKAGE: Place steering levers outward locking them in the neutral position. Turn off engine and raise seat. Under the seat are (4) adjustment bolts. The two adjustment bolts toward the seat mount are adjustments for the forward travel. The two bolts toward the engine are for the reverse travel. Clockwise movement for these will decrease or slow the travel speed of the individual side. Counterclockwise movement will increase the travel of the individual side. The linkage is factory set to maximum performance. Adjustment is made by rotating the adjustment bolt clockwise on the opposite side that the unit tracks toward. Adjust forward and reverse to track straight as needed. When accomplished adjustment to the steering levers may need to be done. This is made by loosening the the two bolts on the steering lever and aligning with the other. Travel of the steering levers from front to rear may be accomplished in the same manner.

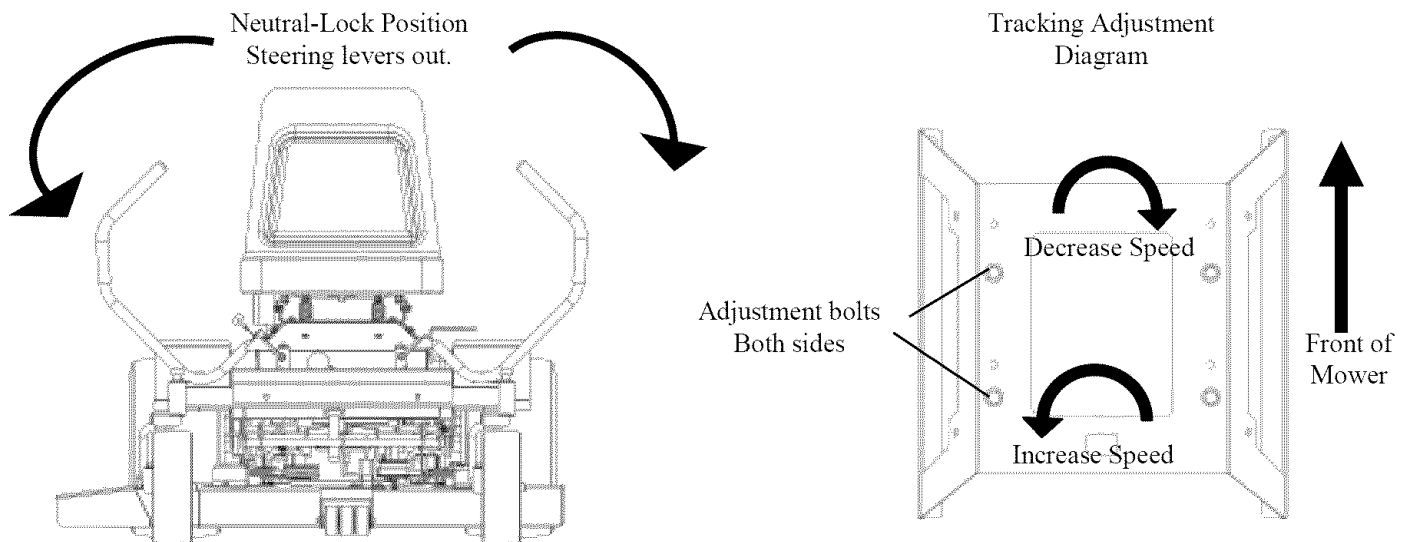

REMOVING THE MOWER DECK

1. Turn off engine and engage parking brake.
2. Rotate cutting height lever counterclockwise to lowest cutting position.
3. Remove bolt from pickup point located at the front of the deck.
4. Remove cotter pins on rear hanger points and slide out stabilizer bars. Disconnect tension spring bolt from tension bracket.
5. Remove belt from mower pulley and electric clutch.
6. Slide mower deck from under unit.

INSTALLING THE MOWER DECK

1. Be sure the cutting height lever is in the lowest position.
2. Position mower deck under unit.
3. Install belt around mower pulley and electric clutch.
4. Install stabilizer bars into rear hanger brackets through lift points and install cotter pins. Be sure eye bolt is between bracket sides.
5. Install bolt in front hanger bracket passing through eyebolt in the same manner as rear and tighten snug.
6. Reattach tension spring bolt and tighten.

NOTE: It is recommended to remove the deck to sharpen the blades.

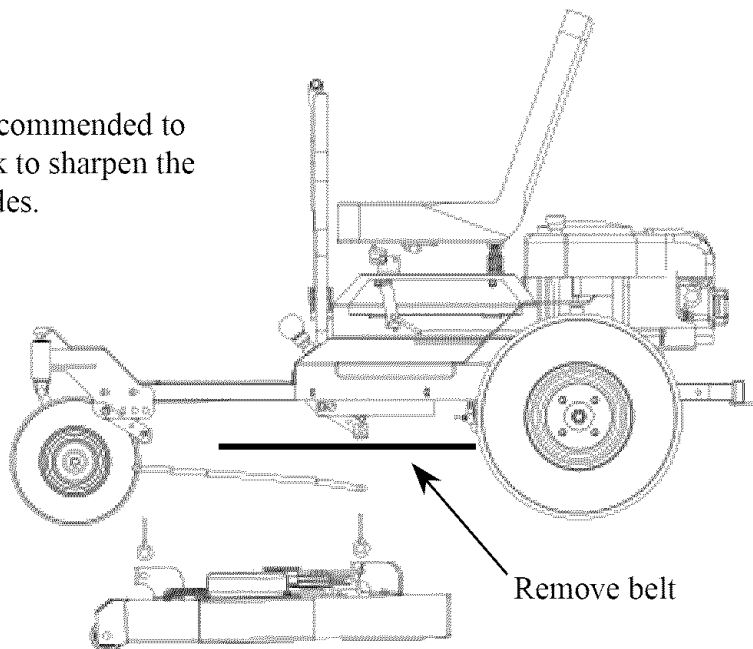

LEVELING THE MOWER DECK

1. Position unit on a smooth level surface.
2. For side to side leveling, measure the distance from the floor to the bottom edge at the rear of the deck. The measurement should be equal within 1/16 inch side to side. Adjustment can be made by loosening locking nut on rear eyebolt hangers and adjusting up or down as needed.
3. For front to rear pitch adjustment, loosen locking nut on front eyebolt and adjust up or down as needed. Proper pitch measurement is 1/8" to 1/4" lower at the front of the deck.

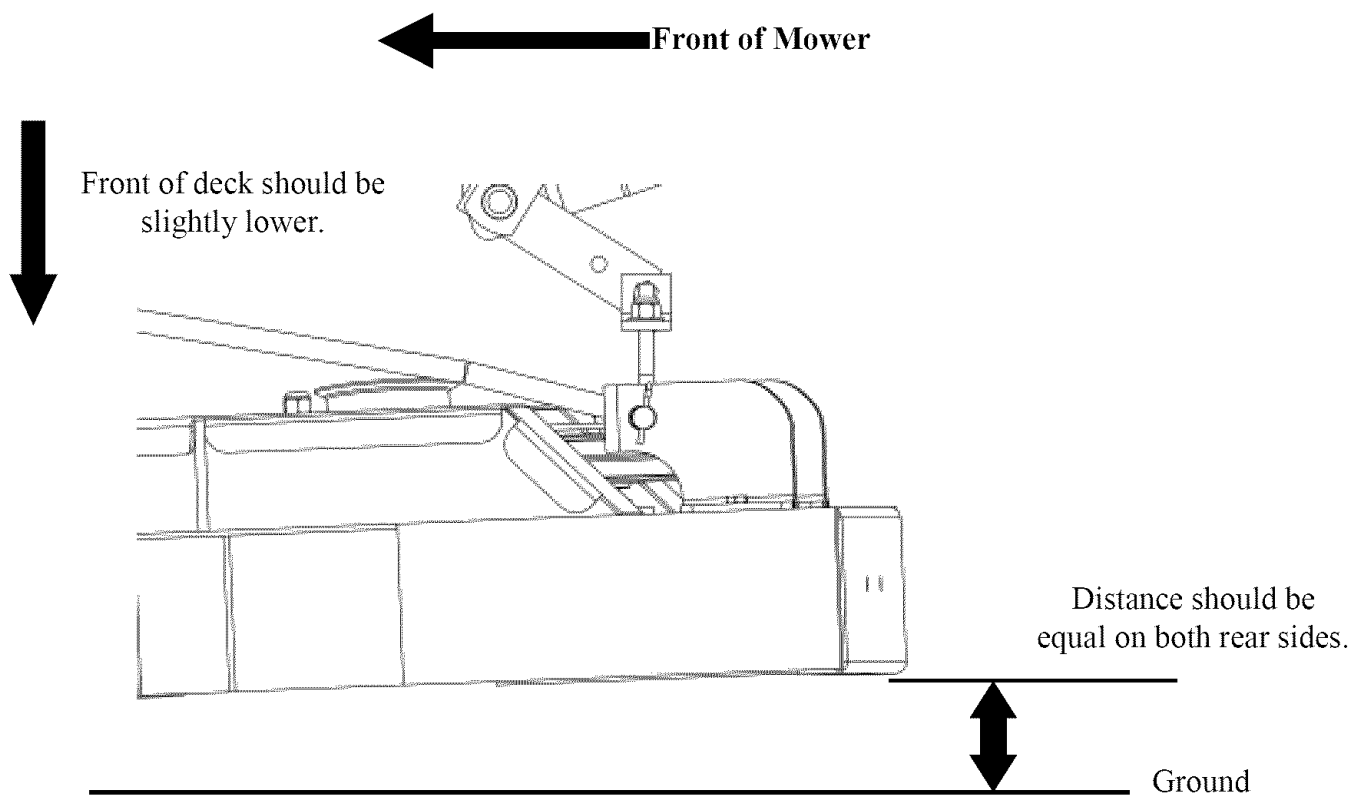

BELTS

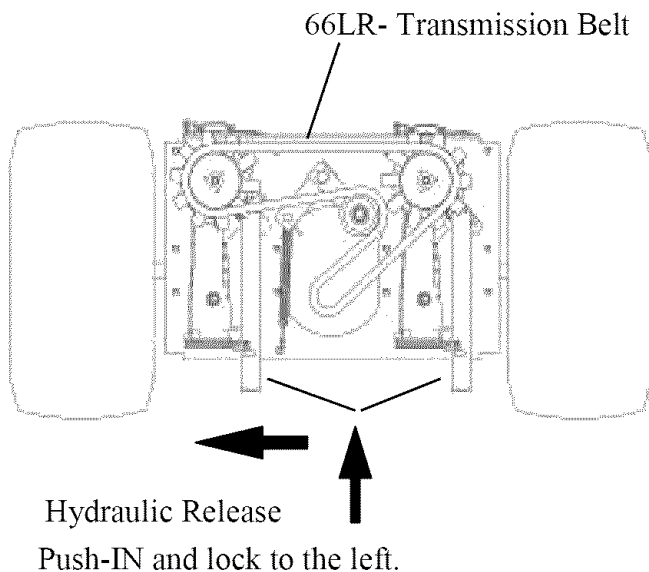
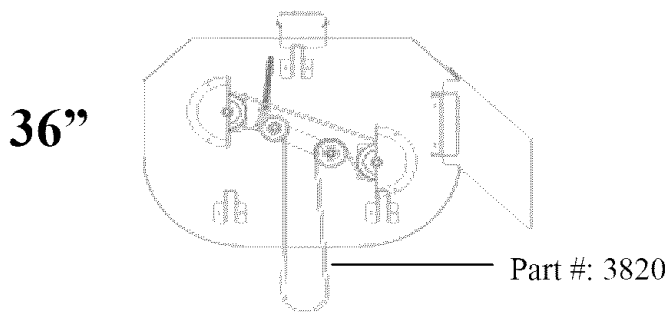
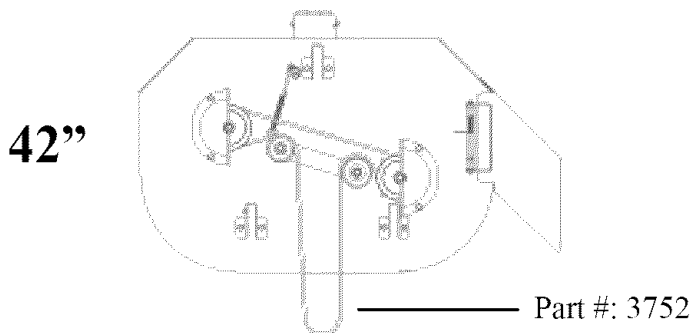
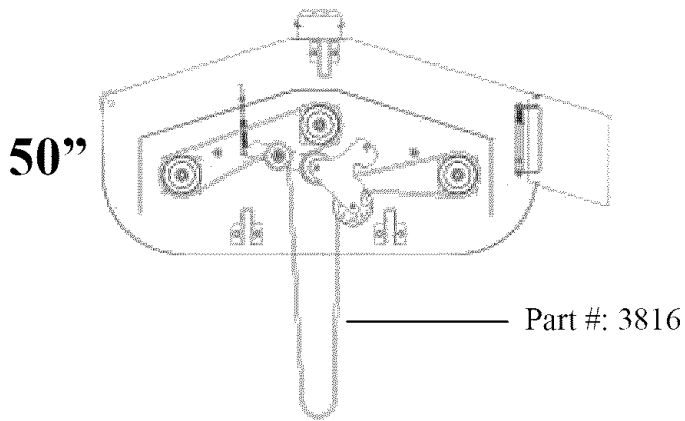

Clutch drive belt replacement

1. Remove belt covers.
2. Disconnect tension idler from tension bracket.
3. Remove belt from mower pulley and electric clutch.
4. Install new belt onto electric clutch and mower pulley and check for proper routing and clearance.
5. Reconnect idler tension bolt to tension bracket.

Hydrostats belt replacement

1. Remove clutch drive belt. *See clutch belt replacement.*
2. Disconnect wiring from electric clutch.
3. Disconnect idler spring from tension bracket.
4. Remove bolt and washer from bottom of electric clutch and slide clutch from engine crankshaft, set aside.
5. Remove belt from transaxles and engine pulley.
6. Install new belt. Check for proper routing and clearance.
7. Reinstall electric clutch carefully aligning keyed portion of clutch and keyway in crankshaft. Reinstall bolt and washer. Washer is "cupped" be sure to place "cupped" side of washer towards the clutch body.
8. Reconnect tension idler to tension bracket.
9. Reconnect wiring harness to electric clutch.
10. Reinstall clutch drive belt. *See clutch drive belt replacement.*

WIRING DIAGRAMS

36" and 42" Mowers

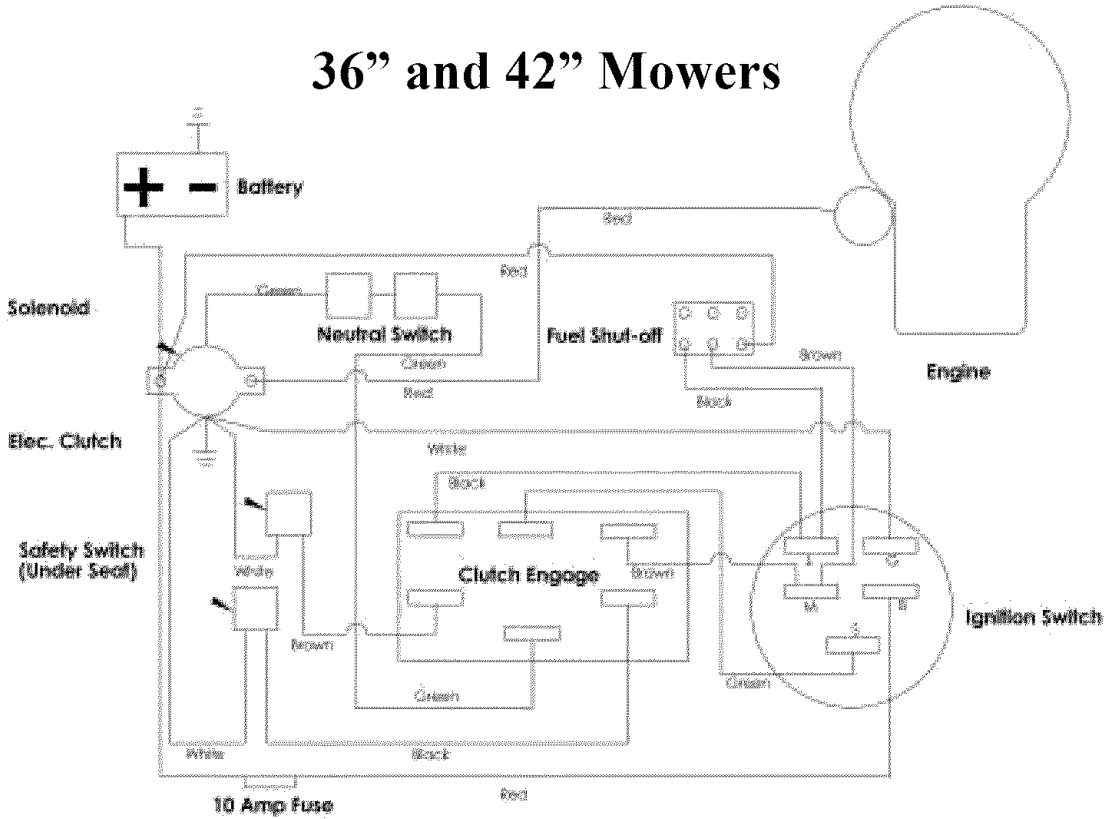

50" Mower

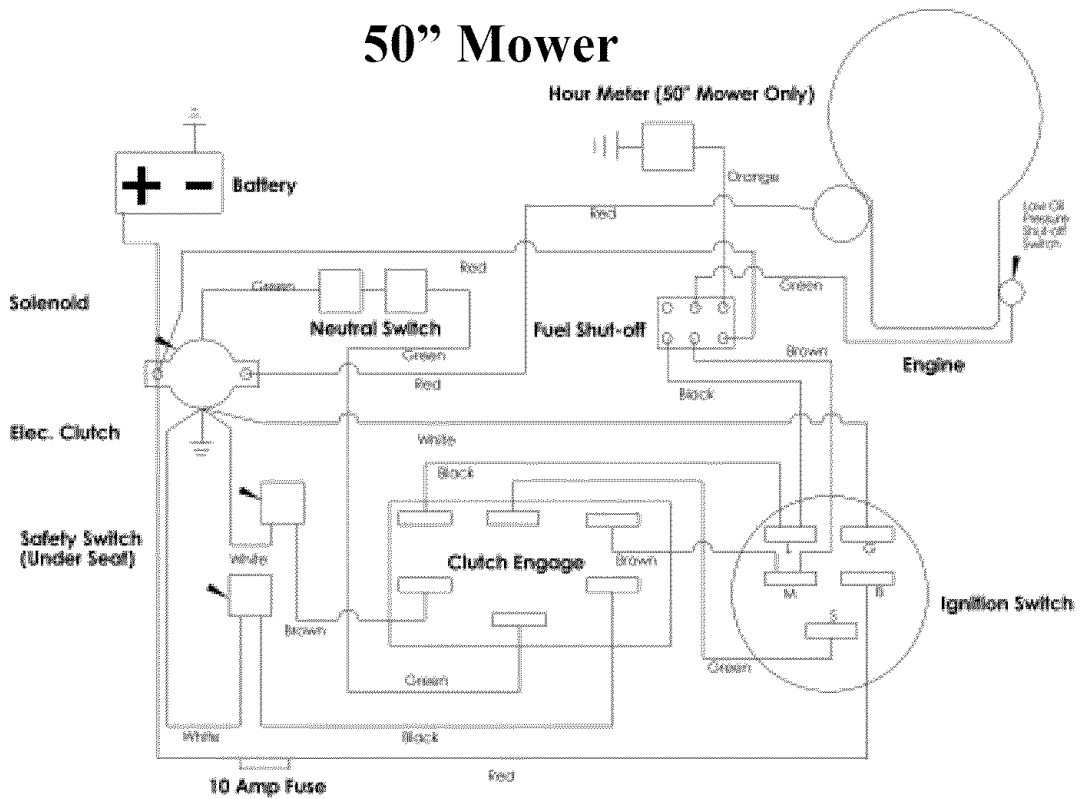

ENGINE SETUP

Item #	Description	Part #
1	14 HP B&S Engine (36" Mower)	N/A
	18.5 HP B&S Engine (42" Mower)	N/A
	22 HP B&S Engine (50" Mower)	N/A
2	5/16-18 Serrated Flange Nut	NB170
3	Spacer Engine Pulley	BB105SL
4	Motor Pulley 3"	3753
5	1/4 X 1/2 Key Stock	4258
6	Engine Pulley Spacer Short .687	689S
7	Electric Clutch Drop Pulley	688ECDP
	Electric Clutch (50" Mower Only)	3813
8	Washer Belleville Engine Pulley	699
9	7/16-20 X 3.25 HCF GR5 ZP	NB705
10	5/16-18 X 1 1/4 Serrated Flange Bolt	NB253
11	Oil Drain Valve	AS122
12	Oil Drain Valve Cap	AS123

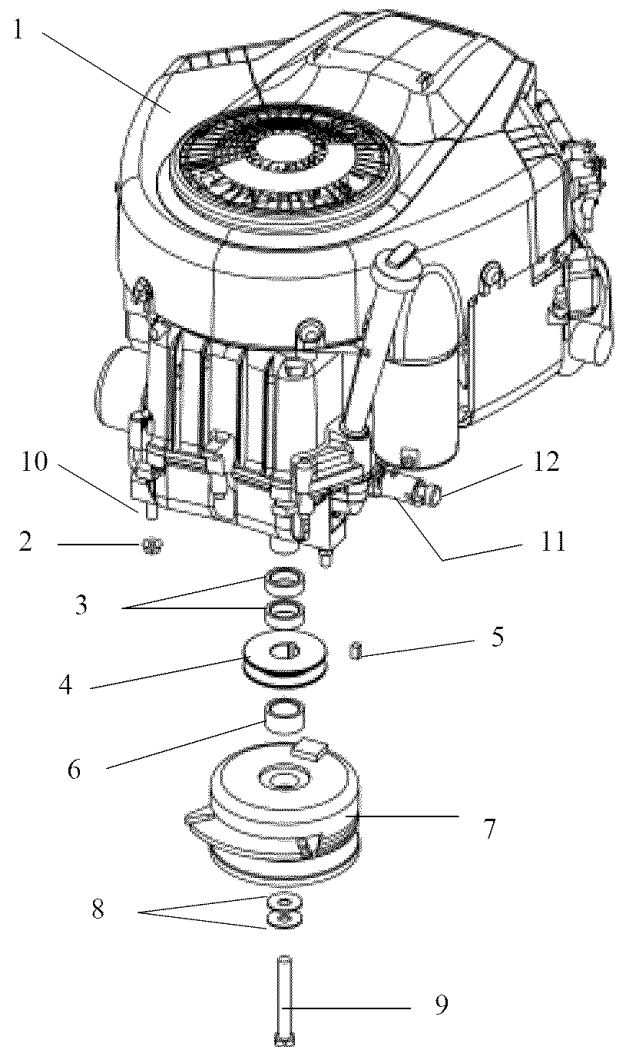

FUEL SUPPLY SYSTEM

Item #	Description	Part #
13	Gas Cap	6102NC
14	Gas Tank Plastic Black	AS100
15	Gas Tank Bracket	3258TK
16	5/16-18 Serrated Flange Nut	NB170
17	5/16 USS Flat Washer ZP	NB556
18	5/16-18 X 1 1/4 Serr. Flange Bolt	NB253
19	1/4-20 X 1/2 Bolt	NB109
20	Fuel Line	AS140
21	Elbow	AS120
22	Rubber Bushing	AS119

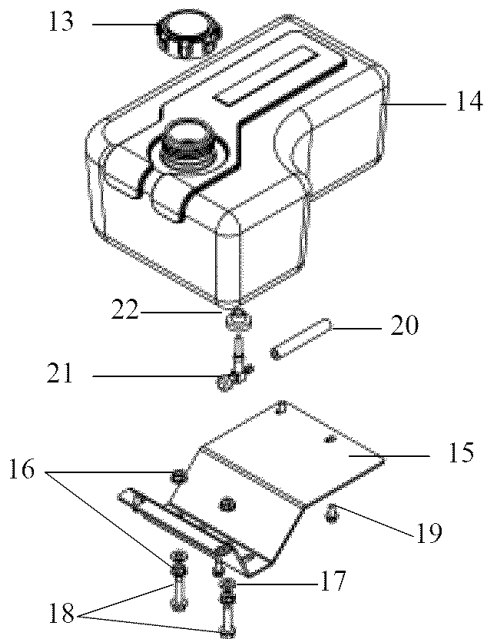

Not Pictured

Description	Part #
Solenoid Assembly (All Models)	9043
Wiring Harness (36 and 42" Models Only)	3720
Wiring Harness (50" Models Only)	3804-04
Hour Meter (50" Models Only)	3803
Battery Cable 10" Red	BCSR
Battery Cable 19 1/2" Black	BCLB
Battery Cable Small Rubber Boot	BCBT
12 Volt Lawn and Garden Battery	U1L
Battery Hold Down, 15" Tarp Strap	BHOLD
Electric Clutch to Wiring Harness Jumper (50" Models Only)	3814

Item #	Description	Part #
1	Wire Link For Idler Arm	BRS6H
2	Clutch Rod Spring	682S
3*	5/16-18 Serrated Flange Nut	NB170
4	5/16-18 X 1 HCC GR5 ZP	NB501
5	Transmission Idler Arm	3690TK
6	1/2-13 X 3 HCC GR5 Bolt ZP	NB131
7	3/8-16 X 1 1/2 HCC GR5 ZP	NB107
8	3/8 SAE Washer	NB272
9	Idler Pulley	B27
10	3/8-16 2-Way Lock Nut	NB280
11	1/2-13 Jam Nut	NB118
12	5/16-18 Nyloc Nut	NB181
13	Hydro Release	3678TK
16*	Wheel Spacer	3825
17	Wheel Hub Lug Nut 1/2-20	2203LN
18	Rear Tire For 36"	3755
	Rear Tire For 42"	3604
	Rear Tire For 50"	3756
19	Transaxle Left	3601CB
20	Transaxle Right	3600CB
21*	Belt Snubber (50" Only)	3819TK
22*	5/16-18 X 3/4 Serr Flg Bolt	NB596
23	1/2-13 Nyloc Nut	NB281
24	5/16-18 ZP 2 Way Lock Nut	NB558

* 50" only

Note: Spring #2 must pivot freely on bolt #4 to prevent pre-mature failure.

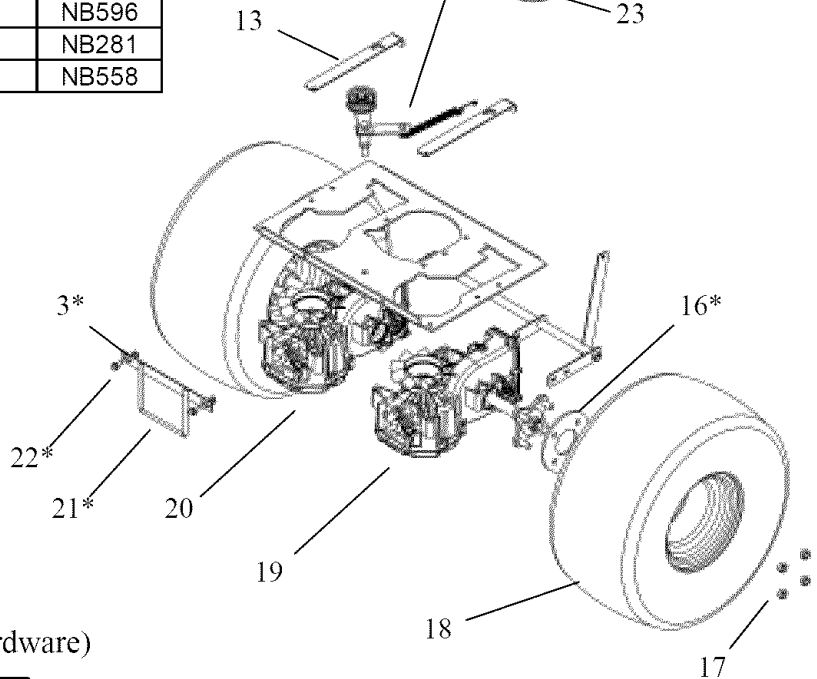
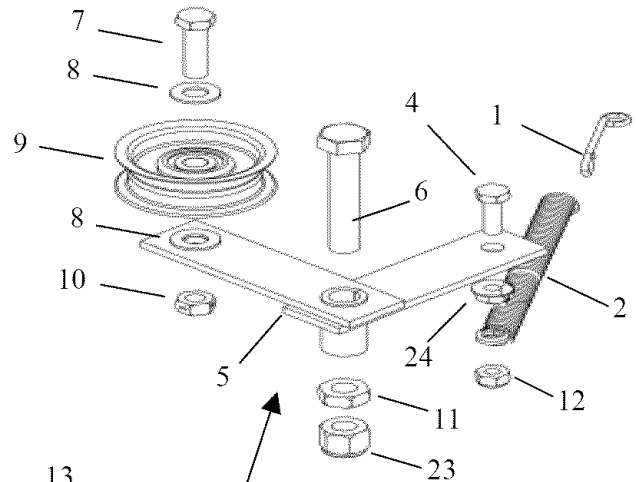

PARTS NOT SHOWN
(Zero Turn Rider Trans Mounting Hardware)

Description	Part #
5/16-18 X 4 HCC GR5 ZP	NB513
5/16-18 X 2 3/4 HCCGR2ZP	NB106
5/16 SAE Washer	NB275
5/16-18 Nyloc Nut	NB181

Description	Part #
1/4-20 X 1 HCC GR5 ZP	NB102
1/4 SAE Washer	NB274
1/4-20 Nyloc Nut	NB180
1/4-20 Flange Nut	NB524

STEERING (RIGHT SIDE SHOWN)

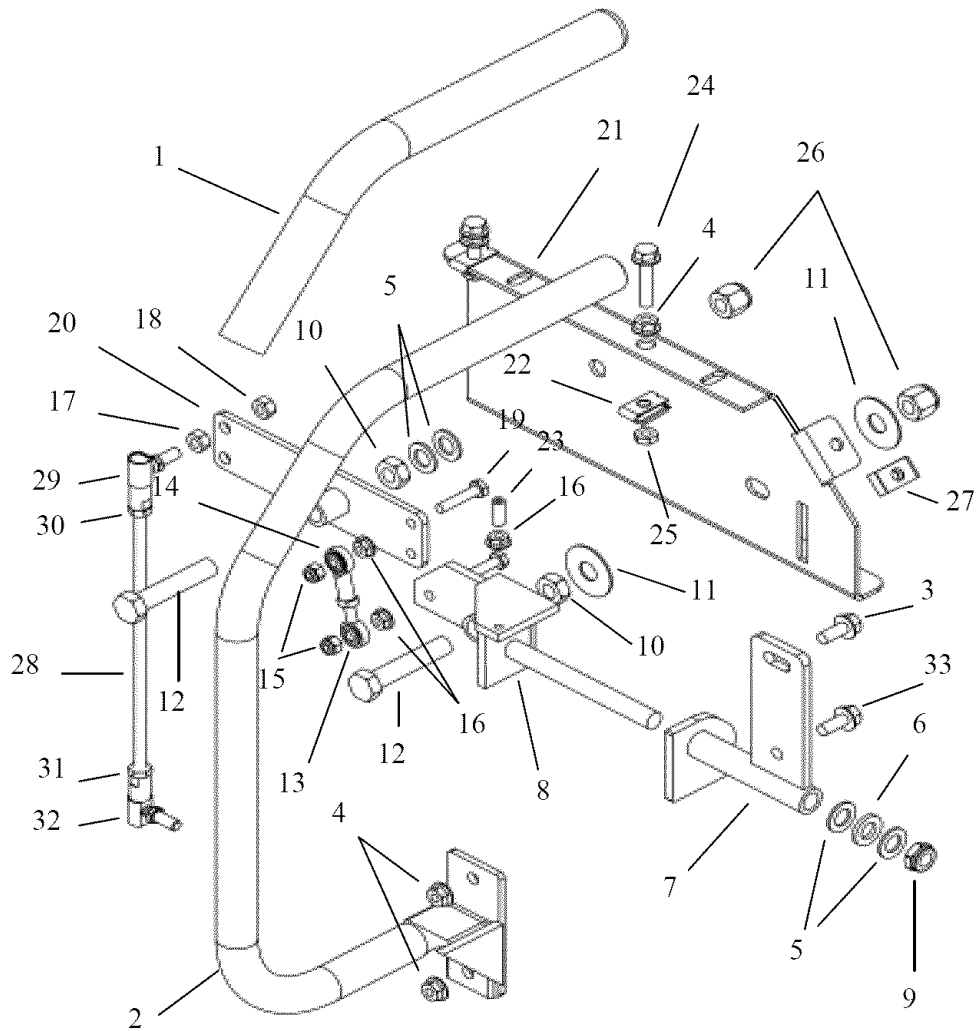

Item #	Description	Part #	Item #	Description	Part #
1	Directional Handle Grip	3673	18	5/16-24 ZP 2-Way Lock Nut	NB448
2	Right Handle-Weldment	3839TK	19	1/4-20 X 1 1/4 HTC GR5 ZP	NB103
	Left Handle-Weldment	3846TK	20	Universal Pivot Plate Weldment	3698TK
3	5/16-18 X 3/4 Serr Flg Bolt	NB596	21	Control Card Right	3621TK
4	5/16-18 Serrated Flange Nut	NB170		Control Card Left	3620TK
5	1/2 NR Mach Bushing 14 GA	NB177	22	Tinnerman Clips 5/16-18 Heavy Duty	3669
6	1/2 ID X 7/8 OD X 1/8 Nylon Washer	NB682	23	1/4-20 X 3/4 SSC Plain	NB310
7	Right Handle Mount Weldment	3841TK	24	5/16-18 X 1 1/2 Flge Serr. Bolt	NB254
	Left Handle Mount Weldment	3840TK	25	5/16-18 ZP 2 Way Lock Nut	NB558
8	Pivot Plate Right Weldment	3699TK	26	1/2-13 Nyloc Nut	NB281
	Pivot Plate Left Weldment	3700TK	27	Tinnerman Clip 5/16-18	3706
9	1/2-13 Nyloc Jam Nut	NB688	28	Left & Right Thread Rod	NB262
10	1/2-13 2-Way Jam Lock Nut	NB121	29	Ball Linkage Right	NB263
11	Washer	TR150W	30	5/16-24 Jam Nut	NB190
12	1/2-13 X 2 1/2 HCC GR5 ZP	NB510	31	5/16-24 Jam Nut Left-Hand Thread	NB265
13	1/4 Rod End Male 1/4-28	3721	32	Ball Linkage Left	NB264
14	1/4 Rod End Female 1/4-28	3708	33	5/16-18 X 1 1/4 Serrated Flange Bolt	NB253
15	1/4-20 Nylok Nut	NB180			
16	1/4-20 Flange Nut	NB524			
17	5/16-24 Hex Nut	NB215			

SEAT BASE ASSEMBLY

Item #	Description	Part #
1	Seat 15" Back No Arm Rest (36" Mower Only)	3790
	Seat 15" Back With Arm Rest (42" Mower Only)	3791
	Seat 18" Back With Arm Rest (50" Mower Only)	3792
2	Seat Plate	3133TK
3	5/16-18 Shoulder Bolt	NB743
4	Seat Bracket	3833TK
5	5/16-18 Nyloc Nut	NB181
6	Tinnerman Clip 5/16-18	3706
7	5/16-18 X 3/4 Serr Flg Bolt	NB596
8	5/16 ID X 1 1/4 OD 11GA Black Nylon Washer	NB116
9	5/16-18 Jam Nut	NB173
10	T Knob 5/16-18	3844
11	Control Cover	3393TK
	Control Cover (36" Mower Only)	3645TK
12	Brake Linkage Rod	3390Z
	E-Brake Link Rod (36" Mower Only)	3651
13	Seat Mount (42" & 50" Mower)	3613TK
	Seat Mount (36" Mower)	3613TC
14	5/16-18 Serrated Flange Nut	NB170
15	5/16 USS Flat Washer ZP	NB556
16	Tapered Spring	3609

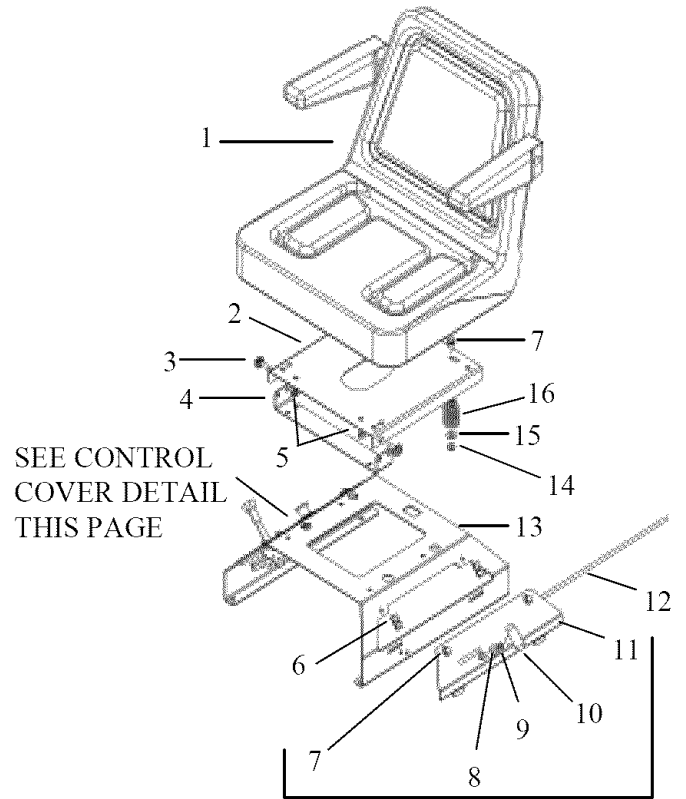

Parking Brake For
42" & 50" Mowers
See Page 20 For
Further Details And
36" Mower Set-Up

CONTROL COVER

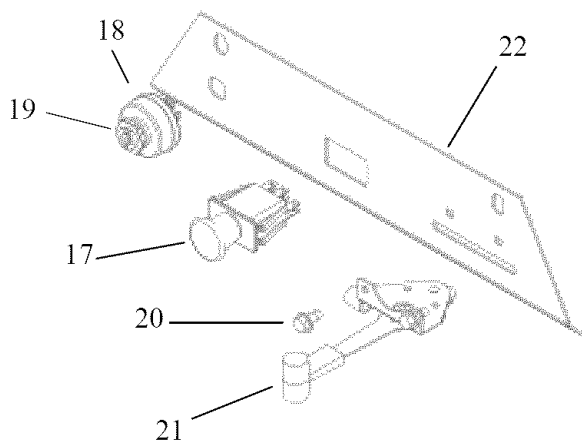

Item #	Description	Part #
17	PTO Switch	3605
18	Key Switch	3623
19	Key Switch Nut	9087
	Key Switch Washer (Not Shown)	9088
20	1/4-20 X 1/2 MSC ZP Hex Washer	NB114
21	Throttle Cable Assembly (36" & 42" Mowers)	3640
	Throttle Control 35" (50" Mower Only)	3788
	"T" Knob only	4226K
22	Control Cover Instruments (Right Side)	3646TK

PARKING BRAKE

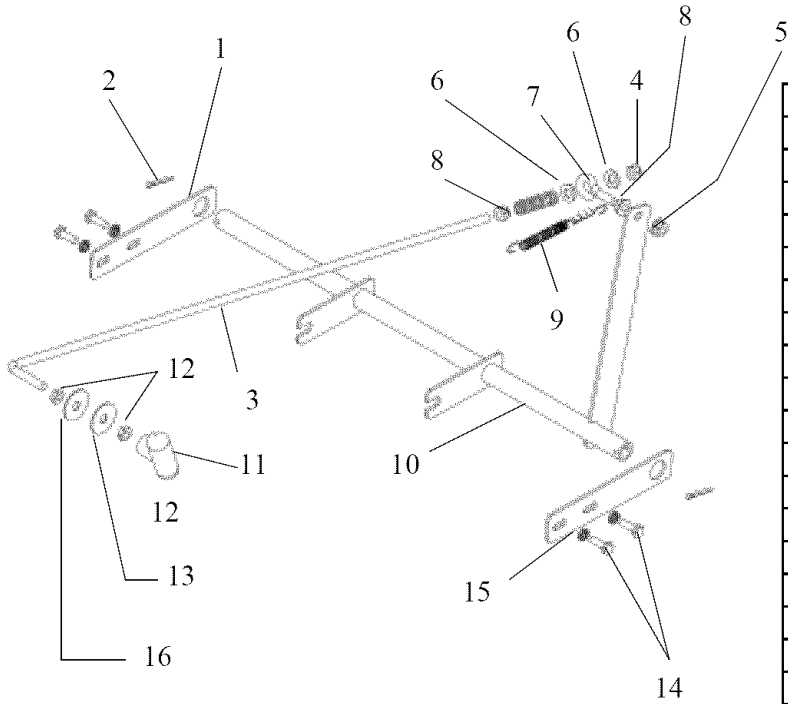

42" & 50" Mowers

Item #	Description	Part #
1	Brake Mount Plate	3267TK
2	1/8 X 1 Cotter Pin	NB126
3	Brake Linkage Rod	3390Z
4	5/16-18 Nyloc Nut	NB181
5	5/16-18 ZP 2 Way Lock Nut	NB558
6	5/16 USS Flat Washer ZP	NB556
7	5/16-18 X 1 Eye Bolt	NB202
8	5/16-18 Serrated Flange Nut	NB170
9	Spring (2 speed)	T2SM
10	Parking Brake Weldment	3797TK
11	T Knob 5/16-18	3844
12	5/16-18 Jam Nut	NB173
13	5/16 11GA Black Nylon Washer	NB116
14	1/4-28 X 3/4 GR5 ZP	NB620
15	1/4 Split Lock Washer	NB135
16	5/16 X 1 1/4 OD Fender Washer	NB579
17	E-Brake Handle	3653TK
18	E-Brake Side link	3651
19	5/16-18 X 1 1/2 GR5 Bolt	NB505
20	5/16-18 X 1 GR5 Bolt	NB501

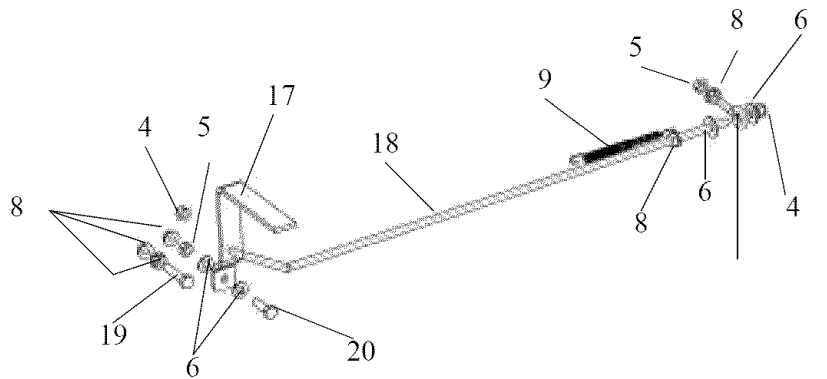

36" Mowers Only

FRAME for 36" Mower

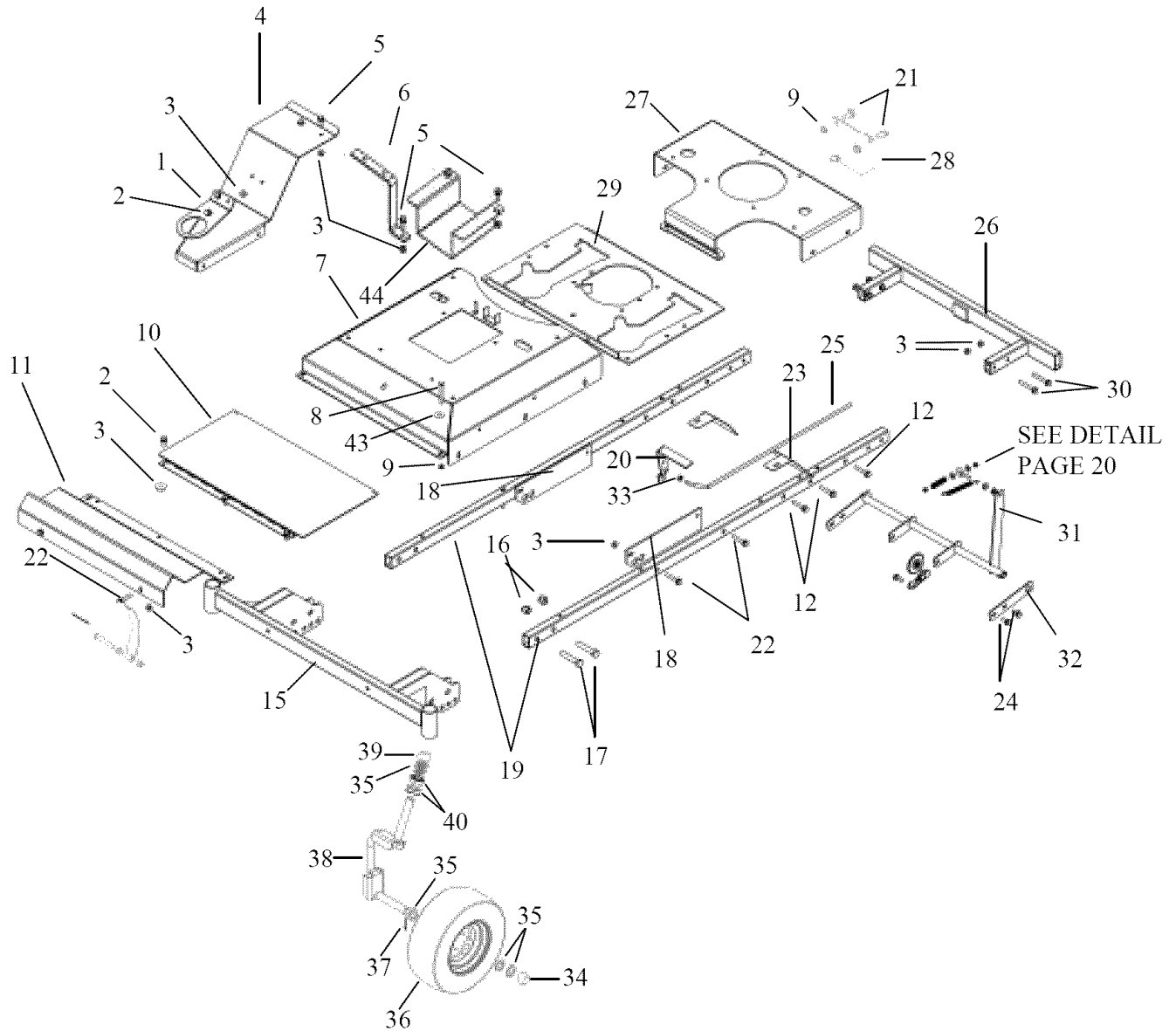

Item #	Description	Part #
1	Beverage Retainer	3643TK
2	5/16-18 X 1/2 Serr. Flg Bolt	NB252
3	5/16-18 Serrated Flange Nut	NB170
4	36" Mower Fender Left	3742TK
	36" Mower Fender Right	3742RTK
5	5/16-18 X 3/4 Serr Flg Bolt	NB596
6	Fender Mount	3654TK
7	Seat Base Weldment	3719TC
8	1/4-20 X 2 1/2 HTC GR5 ZP	NB163
9	1/4-20 Flange Nut	NB524
10	Access Plate Weldment	3269TK
11	Kick Plate	3630TK
12	5/16-18 X 1 1/2 Flange Serr. Bolt	NB254
15	Front Frame Weldment	3261TK
16	1/2-13 2-Way Jam Lock Nut	NB121
17	1/2-13 X 2 1/2 HCC GR5 ZP	NB510
18	Rear Hanger Bracket	3264TK
19	Frame Side Weldment	3639TK
20	E-Brake Handle	3653TK
21	1/4-20 X 3/4 GR5 ZP	NB250
22	5/16-18 X 1 3/4 Flange Serr. Bolt	NB515
23	Transmission Fan Cover-Left	3712TK

Item #	Description	Part #
24	1/4-28 X 3/4 GR5 ZP	NB620
25	E-Brake Side Link	3651
26	Bumper Weldment	3686TK
27	Upper Motor Base	3611TK
28	Rear Cover	3711TK
29	Transmission Mount	3837TK
30	5/16-18 X 2 1/4 Flange Serr. GR5 ZP	NB622
31	Parking Brake Weldment	3797TK
32	Brake Mount Plate	3267TK
33	5/16-18 Nyloc Nut	NB181
34	Caster Debris Cap	AS249
35	13/16 X 1 1/4 X 1/8 Washer	NB195
36	Tire	3754
37	1/8 X 1 Cotter Pin	NB126
38	Caster Weldment ZP	5072
39	3/4 Push Nut Blk Plastic	NB687
40	Bearing, Flanged 3/4 ID	CB58
43	1/4 SAE Washer	NB274
44	Battery Box	3696TK

FRAME for 42" Mower

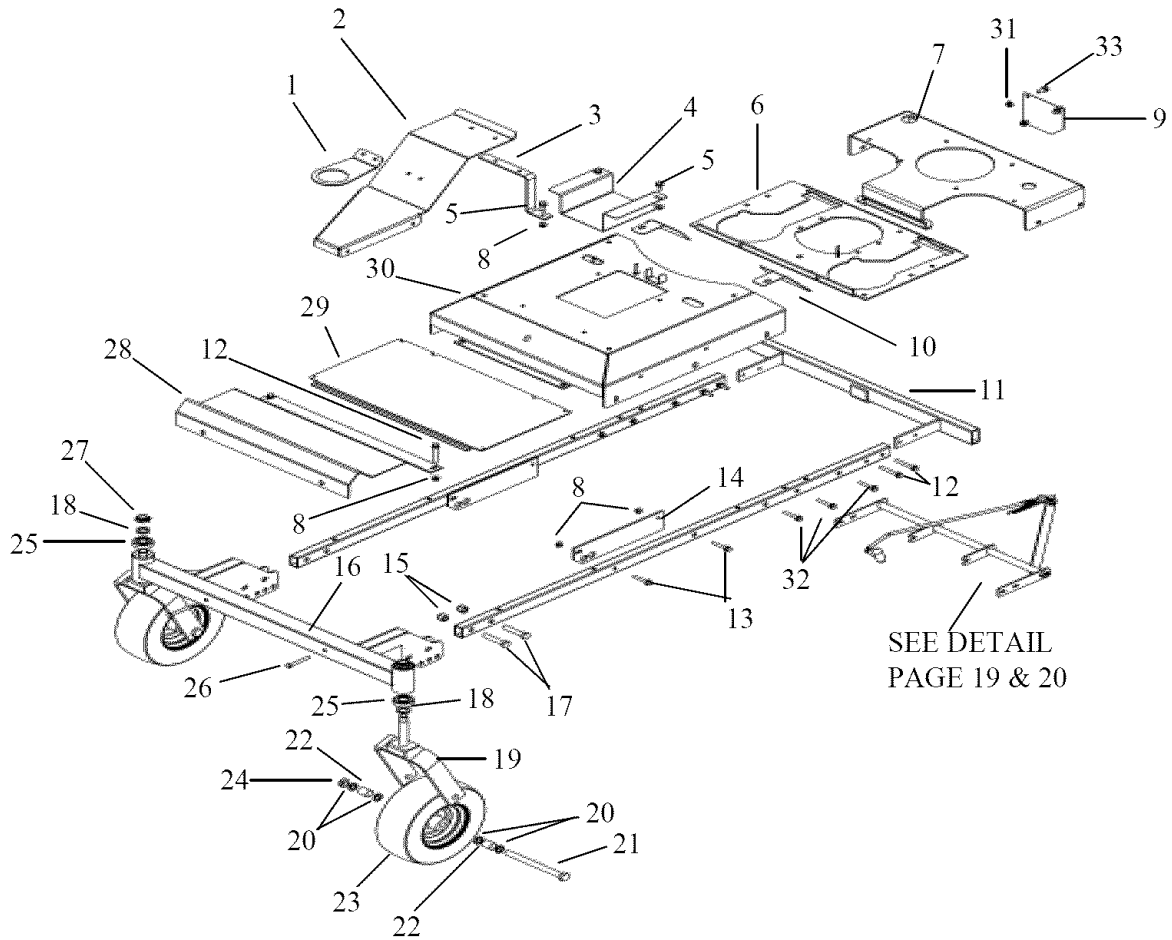

Item #	Description	Part #
1	Beverage Retainer	3643TK
2	Fender-Right	3012TK
	Fender-Left	3011TK
3	Fender Mount	5142TK
4	Battery Box	3696TK
5	5/16-18 X 3/4 Serr Flg Bolt	NB596
6	Transmission Mount	3837TK
7	Upper Motor Base	3611TK
8	5/16-18 Serrated Flange Nut	NB170
9	Rear Cover	3711TK
10	Transmission Fan Cover-Left	3712TK
	Transmission Fan Cover-Right	3806TK
11	Bumper Weldment	3686TK
12	5/16-18 X 2 1/4 Flang Serr. GR5 ZP	NB622
13	5/16-18 X 1 3/4 Flge Serr Bolt	NB515
14	Rear Hanger Bracket	3264TK
15	1/2-13 2-Way Jam Lock Nut	NB121

Item #	Description	Part #
16	Front Axle-Weldment	3401TK
17	1/2-13 X 2 1/2 HCC GR5 ZP	NB510
18	13/16 X 1 1/4 X 1/8 Washer	NB195
19	Caster Fork	665TK
20	5/8 ID X 1 OD 10 GA Washer	NB178
21	5/8-11 X 7 HCC GR5 ZP	NB624
22	Wheel Spacer	3395
23	Front Tire	3009
24	5/8-11 2 Way Lock Jam Nut	NB595
25	Bearing	B98
26	5/16-18 X 2 1/2 HCC GR5 ZP	NB138
27	3/4-16 Jam Nylok Nut	NB122
28	Kick Plate	3396TK
29	Access Plate	3397TK
30	Seat Base Weldment	3719TK
31	1/4-20 Flange Nut	NB524
32	5/16-18 X 1 1/2 Flge Serr. Bolt	NB254
33	1/4-20 X 3/4 GR5 ZP	NB250

FRAME for 50" Mower

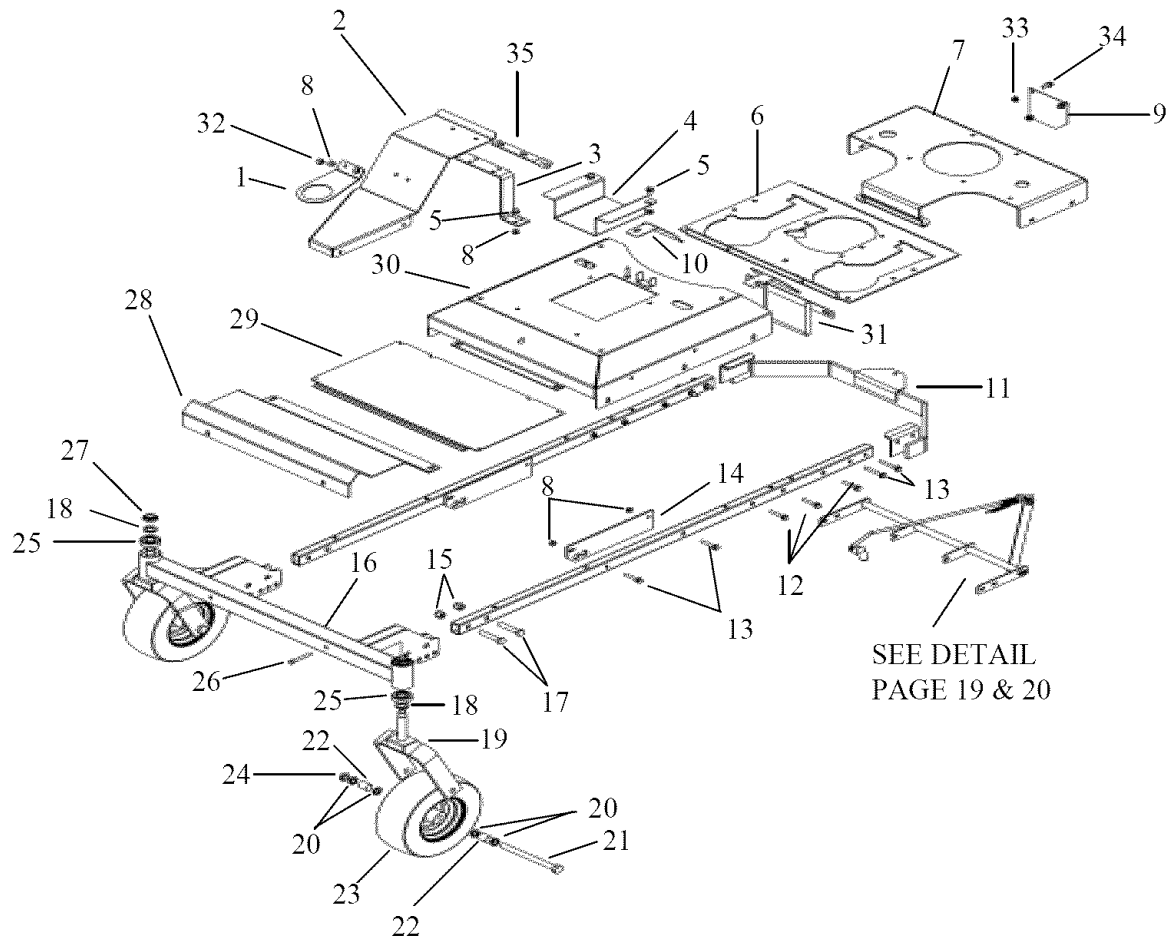

Item #	Description	Part #
1	Beverage Retainer	3643TK
2	Fender-Right	3012TK
	Fender-Left	3011TK
3	Fender Mount	5142TK
4	Battery Box	3696TK
5	5/16-18 X 3/4 Serr Flg Bolt	NB596
6	Transmission Mount	3835TK
7	Upper Motor Base	3777TK
8	5/16-18 Serrated Flange Nut	NB170
9	Rear Cover	3711TK
10	Transmission Fan Cover-Right	3806TK
	Transmission Fan Cover-Left	3712TK
11	Bumper Weldment	3778TK
12	5/16-18 X 1 1/2 Flge Serr. Bolt	NB254
13	5/16-18 X 1 3/4 Flge Serr Bolt	NB515
14	Rear Hanger Bracket	3264TK
15	1/2-13 2-Way Jam Lock Nut	NB121
16	Front Axle-Weldment	3401TK
17	1/2-13 X 2 1/2 HCC GR5 ZP	NB510

Item #	Description	Part #
18	13/16 X 1 1/4 X 1/8 Washer	NB195
19	Caster Fork	665TK
20	5/8 ID X 1 OD 10 GA Washer	NB178
21	5/8-11 X 7 HCC GR5 ZP	NB624
22	Wheel Spacer	3395
23	Front Tire	3010
24	5/8-11 2 Way Lock Jam Nut	NB595
25	Bearing	B98
26	5/16-18 X 2 1/2 HCC GR5 ZP	NB138
27	3/4-16 Jam Nylok Nut	NB122
28	Kick Plate	3396TK
29	Access Plate	3397TK
30	Seat Base Weldment	3719TK
31	Belt Snubber	3819TK
32	5/16-18 X 1/2 Serr. Flg Bolt	NB252
33	1/4-20 Flange Nut	NB524
34	1/4-20 X 3/4 GR5 ZP	NB250
35	Choke Mount	3810TK

DECK LIFT

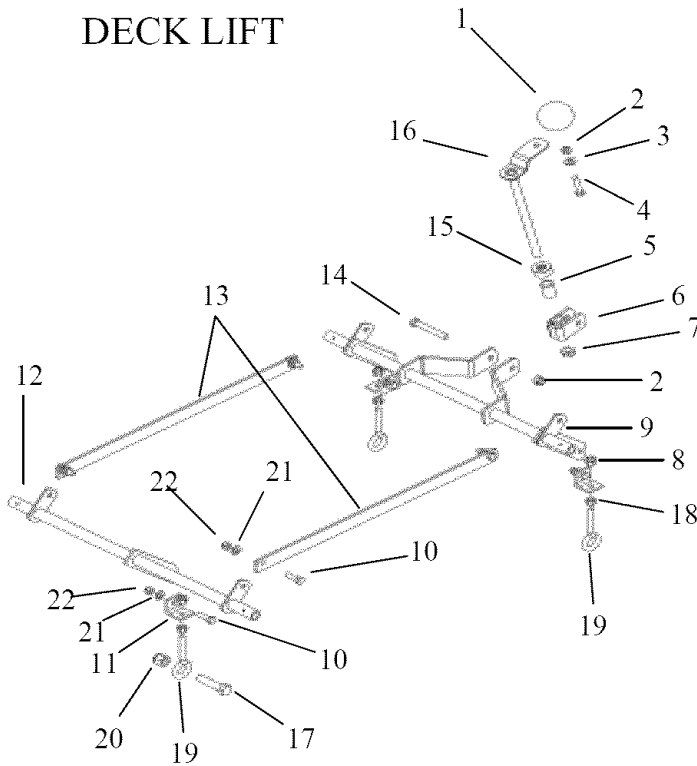

Item #	Description	Part #
1	Plastic Knob - Black	4857
2	3/8-16 2-Way Lock Nut	NB280
3	5/16 USS Flat Washer ZP	NB556
4	3/8-16 X 1 1/4 GR5 ZP	NB618
5	Spacer 3/4 OD X .515 ID DOM X 1.125	3379
6	Rear Height Lifter	3705TK
7	1/2-13 Nyloc Nut	NB281
8	3/8-16 Nyloc Nut	NB182
9	Rear Torsion Weldment	3684TK
10	5/16-18 X 1 HCC GR5 ZP	NB501
11	Lift Pivot	3683TK
12	Front Torsion Weldment	3683TK
13	Front - Back Height Link	3260TK
14	3/8-16 X 2 1/2 HTC GR5 ZP	NB619
15	Banded Thrust Bearing	T151
16	Height Adjust Crank	3266TK
17	1/2-13 X 2 HCC GR5 ZP	NB509
18	3/8-16 Jam Nut ZP	NB174
19	3/8-16 X 2 1/4 Eye Bolt	NB204
20	1/2-13 Nyloc Nut	NB281
21	5/16 SAE Washer	NB275
22	5/16-18 Nyloc Nut	NB181

HEIGHT ADJUST INDICATOR

Item #	Description	Part #
23	Height Adjust Indicator	3671TK
	Height Adjust Indicator Decal	OD99151
24	Height Adjust Indicator Bracket	3845TK
25	8-32 Nut	NB201
25B	8-32 Machine Screw	NB689
26	5/16-18 X 2 GR5 Bolt	NB507
27	5/16-18 2 way Lock Nut	NB558
28	5/16-18 Nyloc Nut	NB181

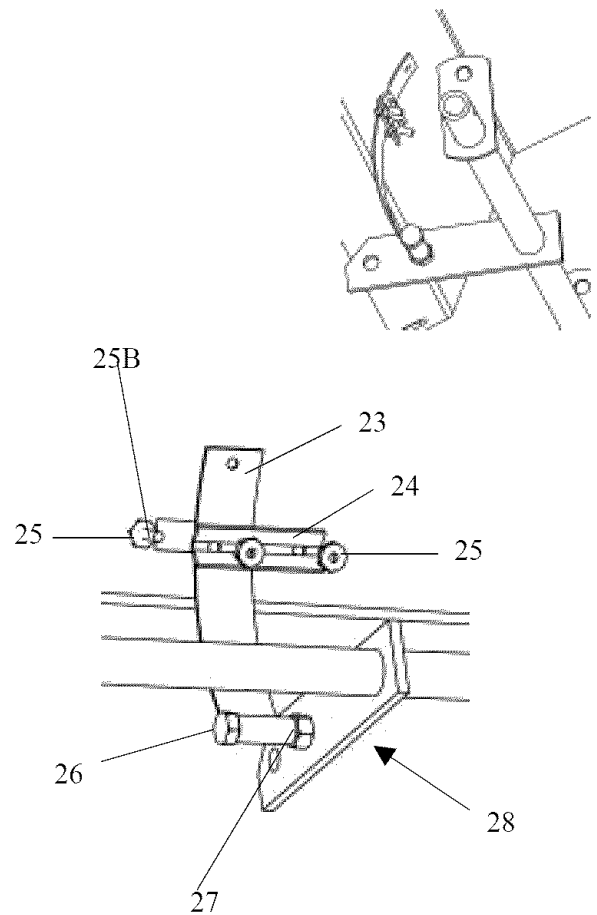

BLADE DRIVER
For 42 and 50" Mowers

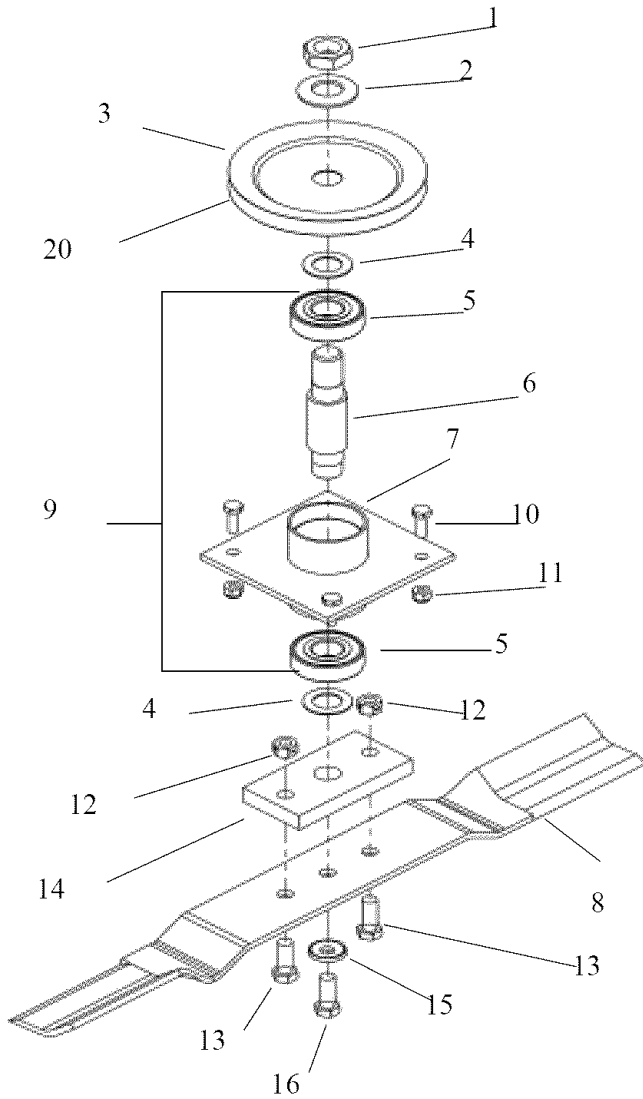

BLADE DRIVER
For 36" Mowers

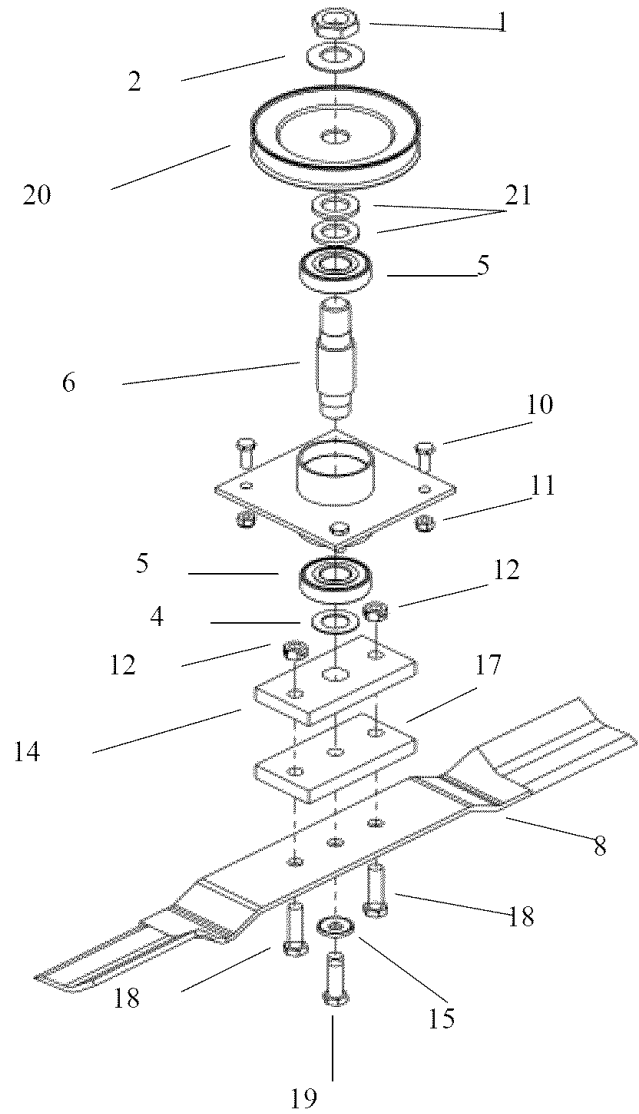

Item #	Description	Part #	Item #	Description	Part #
1	3/4-16 2 Way Lock Nut	NB175	10	1/4-20 X 3/4 GR5 ZP	NB250
2	1.5x.761x.098x.134 Belleville Washer	AS155	11	1/4-20 Nylok Nut	NB180
3	Blade Pulley- 5.5" (42" Mower Only)	6114TK	12	3/8-24 Two Way Locknut	NB216
4	Washer For Blade Driver	NB179	13	3/8-24 X 1 Bolt	NB238
5	Blade Bearing	B98	14	Blade Mount Plate	9008
6	Blade Shaft 4.25"	9076	15	SP Washer Bellv. PLN .413 X .945 X .118	NB607
7	Bearing Housing	B99ECTK	16	3/8-24 X 1 Engine Bolt Locktite	NB238N
8	36" Mower - 18" Blade	9014	17	Blade Mount Plate Spacer (36" Only)	9024
	42" Mower - 20 1/2" Blade	9004	18	3/8-24 X 1 1/2 HCC GR5 ZP (36" Only)	NB167
	42" Mower - 22" Blade	9005	19	3/8-24 X 1 1/2 HCC GR5 ZP Locktite (36" Only)	NB167N
	17.5" Blade for 50" Mower	5059	20	Blade Pulley 4.5" (36" & 50" Only)	B4104TK
9	Blade Driver Assy	9018	21	3/4ID X 1 1/4OD 10 GA. Washer	NB184

36" MOWING DECK

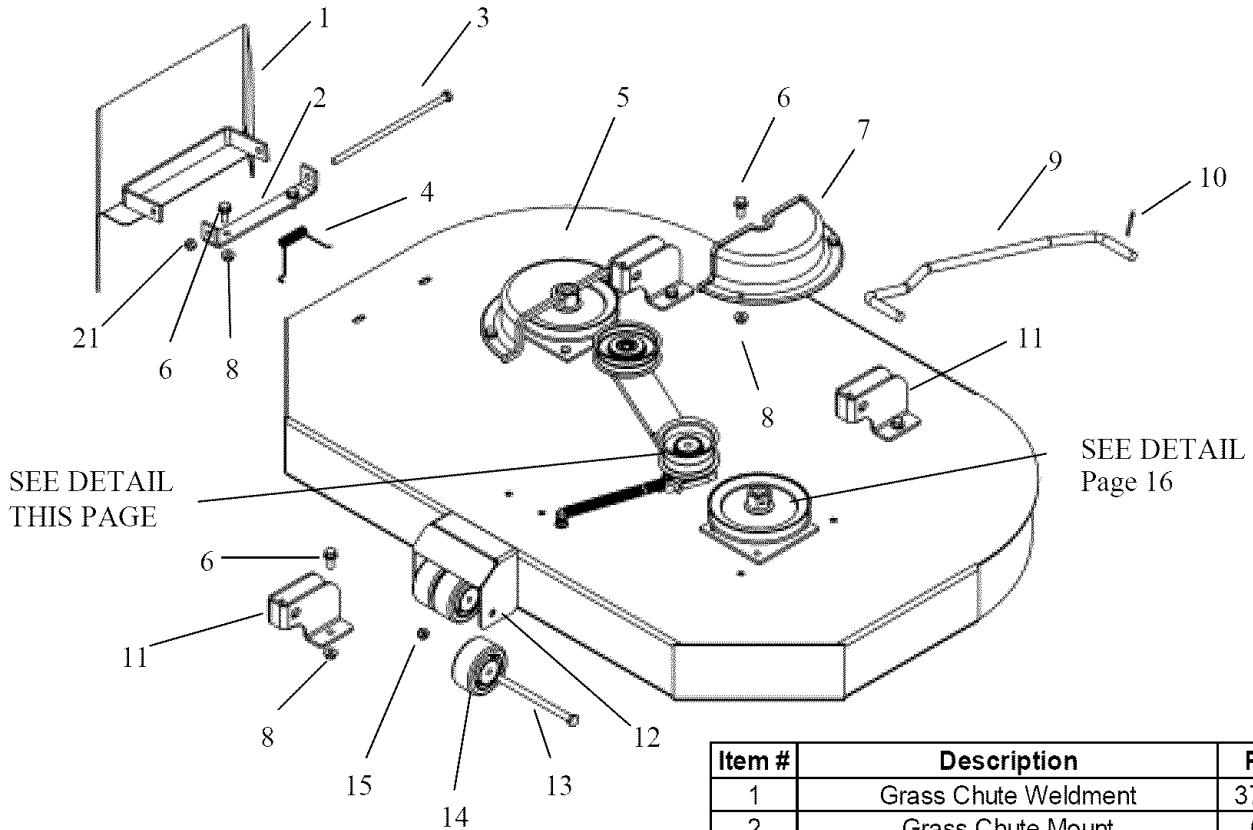

NOT SHOWN
Roller Bracket (12) Mounting Hardware

DESCRIPTION	PART #	QTY
5/16-18 X 3/4 Serr Flg Bolt	NB596	2
5/16-18 Serrated Flange Nut	NB170	2

Item #	Description	Part #
1	Grass Chute Weldment	3757TK
2	Grass Chute Mount	6030
3	5/16-18 X 8 1/2 HCC GR2 ZP	NB136
4	Torsion Spring - Bent Leg	9100
5	Deck Weldment	3750TC
6	5/16-18 X 3/4 Serr Flg Bolt	NB596
7	Pulley Cover	3743
8	5/16-18 Serrated Flange Nut	NB170
9	Sway Bar Left	3665
	Sway Bar Right	3664
10	1/8 X 1 Cotter Pin	NB126
11	Lift Bracket	3738TK
12	Front Roller Bracket	4018TK
13	3/8-16 X 5 1/2 GR5 ZP	NB575
14	Anti-Scalp Roller	AS001
15	3/8-16 Nyloc Nut	NB182
16	3/8-16 X 2 1/2 HCC GR5 ZP	NB221
17	3/8 SAE Washer	NB272
18	Idler Pulley	B527
19	Idler Bushing	6037
20	Idler Spacer	6040
21	5/16-18 Nyloc Nut	NB181
22	5/16-18 X 1 HCC GR5 ZP	NB501
23	Clutch Rod Spring	682S
24	Idler Pulley	7509
25	3/8-16 X 2 HCC GR5 ZP	NB198
26	Idler Weldment	3848TK
27	3/8-16 2-Way Lock Nut	NB280

DECK IDLER

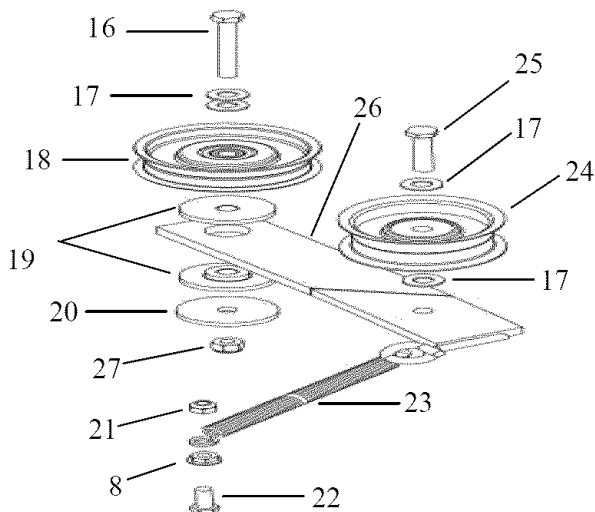

42" MOWING DECK

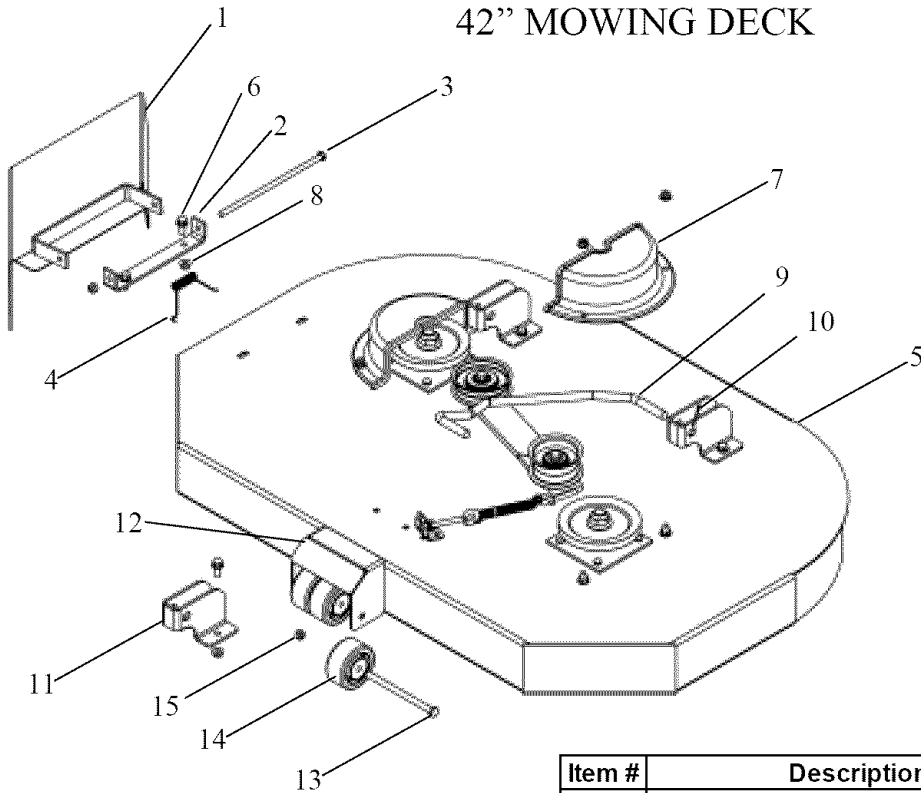

NOT SHOWN

Roller Bracket (12) Mounting Hardware

DESCRIPTION	PART #	QTY
5/16-18 X 3/4 Serr Flg Bolt	NB596	2
5/16-18 Serrated Flange Nut	NB170	2

Item #	Description	Part #
1	Grass Chute Weldment	3757TK
2	Grass Chute Mount	6030TK
3	5/16-18 X 8 1/2 HCC GR2 ZP	NB136
4	Torsion Spring - Bent Leg	9100
5	Deck Weldement	3762TK
6	5/16-18 X 3/4 Serr Flg Bolt	NB596
7	Pulley Cover	3743
8	5/16-18 Serrated Flange Nut	NB170
9	Sway Bar Left	3665
	Sway Bar Right	3664
10	1/8 X 1 Cotter Pin	NB126
11	Lift Bracket	3738TK
12	Front Roller Bracket	4018TK
13	3/8-16 X 5 1/2 GR5 ZP	NB575
14	Anti-Scalp Roller	AS001
15	3/8-16 Nyloc Nut	NB182
16	3/8-16 X 2 1/2 HCC GR5 ZP	NB221
17	3/8 SAE Washer	NB272
18	Idler Pulley	B527
19	Idler Bushing	6037
20	Idler Spacer	6040
21	Seat Hinge	3808TK
22	5/16-18 Nyloc Nut	NB181
23	5/16-18 Eye Bolt	NB315
24	Two Speed Spring	TZ2S
25	3/8-16 2-Way Lock Nut	NB280
26	Idler Pulley	7509
27	3/8-16 X 2 HCC GR5 ZP	NB198
28	Idler Weldment	3850TK
29	5/16-18 Jam Nut	NB173
30	Washer Bellvl. 413 X .945 X .118	NB607

DECK IDLER

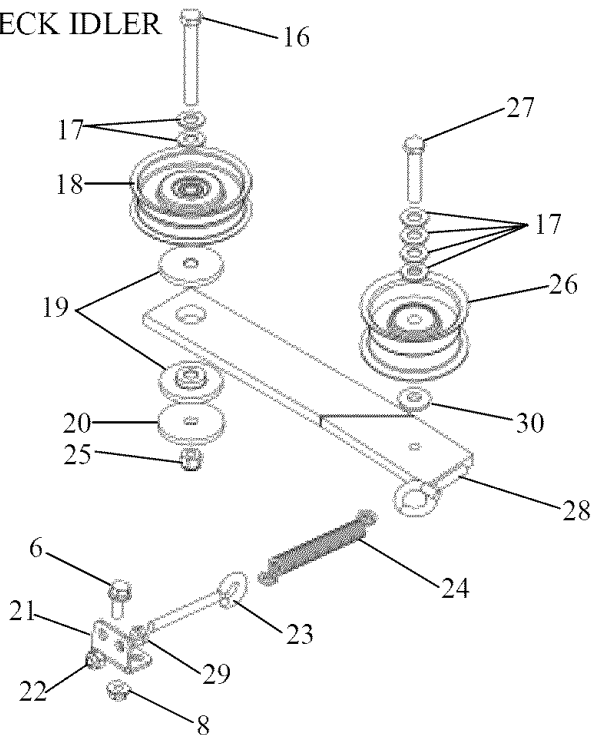

50" MOWING DECK

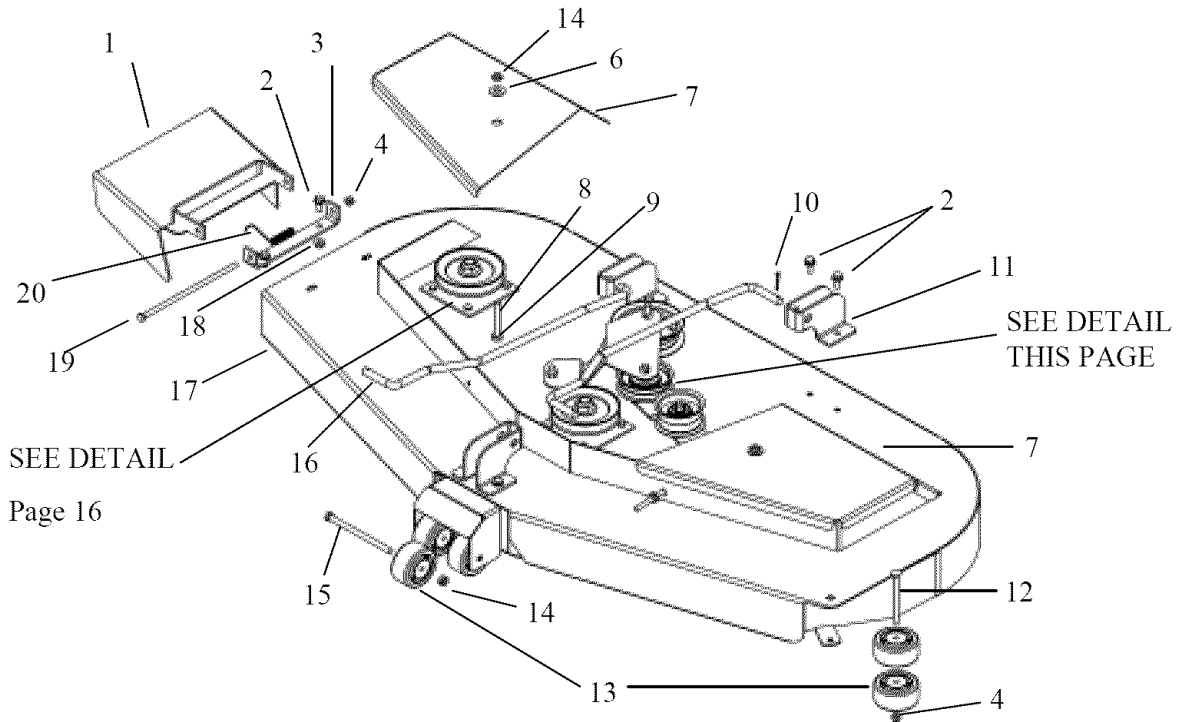

DECK IDLER

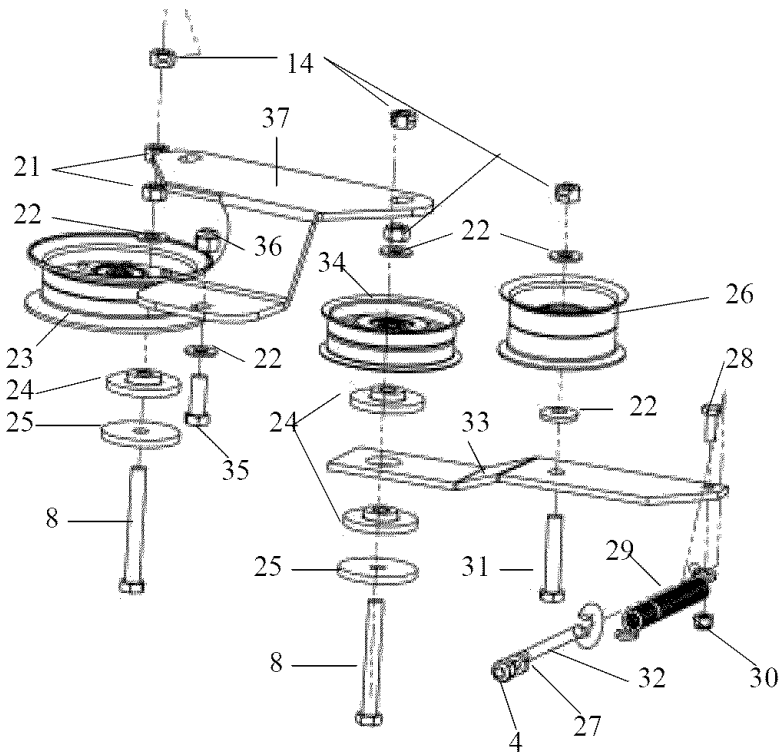

Item #	Description	Part #
1	Grass Chute Weldment	3773TK
2	5/16-18 X 3/4 Serr Flg Bolt	NB596
3	Grass Chute Mount	6030TK
4	5/16-18 Nyloc Nut	NB181
5	3/8-16 Nylok Nut Jam	NB207
6	3/8 USS Washer	NB271
7	Belt Cover-Right	3769TK
	Belt Cover-Left	3768TK
8	3/8-16 X 3 HTC GR5 ZP	NB164
9	3/8-16 Kep Nut	NB205
10	1/8 X 1 Cotter Pin	NB126
11	Lift Bracket	3738TK
12	5/16-18 X 4 Carriage Bolt	NB101
13	Anti-Scalp Roller	AS001
14	3/8-16 2-Way Lock Nut	NB280
15	3/8-16 X 5 1/2 GR5 ZP	NB575
16	Sway Bar-Right	3664
	Sway Bar-Left	3665
17	Deck Weldment	3766TK
18	5/16-18 Serrated Flange Nut	NB170
19	5/16-18 X 8 1/2 HCC GR2 ZP	NB136
20	Torsion Spring	9100
21	3/8-16 HNC GR2 ZP	NB212
22	3/8 SAE Washer	NB272
23	Idler Pulley	3786
24	Idler Bushing	6037
25	Idler Spacer	6040
26	Idler Pulley	7509
27	5/16-18 Jam Nut	NB173
28	1/4-20 X 3/4 GR5 ZP	NB250
29	Two Speed Spring	TZ2S
30	1/4-20 Nylok Nut	NB180
31	3/8-16 X 2 HCC GR5 ZP	NB198
32	5/16-18 Eye Bolt	NB315
33	Deck Idler Arm	3770TK
34	Idler Pulley	B527
35	3/8-16 X 1 GR5 ZP Bolt	NB604
36	3/8-16 Nyloc Nut	NB182
37	Pulley Brace	3772TK

TROUBLESHOOTING

SYMPTOM	CAUSE	CORRECTION
ENGINE HARD TO START	<ol style="list-style-type: none"> 1. WEAK OR DEAD BATTERY 2. AIR FILTER DIRTY 3. BAD SPARK PLUG 4. FUEL FILTER DIRTY 5. STALE OR CONTAMINATED FUEL 6. CARBURATOR OUT OF ADJUSTMENT 	<ol style="list-style-type: none"> 1. REPLACE OR RECHARGE 2. CLEAN OR REPLACE 3. REPLACE SPARK PLUG 4. REPLACE FUEL FILTER 5. DRAIN AND REPLACE WITH FRESH FUEL 6. CONTACT NEAREST BRIGGS&STRATTON SERVICE REPRESENTATIVE
ENGINE WILL NOT START OR LOSS OF POWER	<ol style="list-style-type: none"> 1. STEERING LEVERS NOT IN NEUTRAL LOCKED POSITION 2. PTO SWITCH IS ENGAGED 3. THROTTLE NOT SET PROPERLY OR NOT PROPERLY "CHOKED" 4. ENGINE FLOODED 5. DIRTY FUEL FILTER 6. DIRTY AIR FILTER 7. CONTAMINATED FUEL 8. BLOWN FUSE 9. BAD SPARK PLUG OR LOOSE PLUG WIRE 10. DIRTY ENGINE AIR SCREENS 11. WEAK OR DEAD BATTERY 12. CARBURATOR OUT OF ADJUSTMENT 13. OUT OF FUEL 14. CORRODED BATTERY TERMINALS 15. LOOSE OR DAMAGED WIRING 16. LOW OR DIRTY OIL 17. DEBRIS BUILT-UP UNDER DECK 	<ol style="list-style-type: none"> 1. MOVE LEVERS INTO POSITION 2. PUSH PTO SWITCH IN 3. SEE START UP IN OPERATION SECTION 4. WAIT SEVERAL MINUTES BEFORE STARTING 5. REPLACE WITH NEW FILTER 6. REPLACE OR CLEAN 7. DRAIN AND REPLACE WITH FRESH FUEL 8. REPLACE FUSE 9. REPLACE PLUG AND TIGHTEN PLUG WIRE 10. CLEAN ENGINE AIR SCREENS 11. REPLACE OR RECHARGE 12. CONTACT NEAREST BRIGGS&STRATTON SERVICE REPRESENTATIVE 13. REPLACE WITH FRESH FUEL 14. CLEAN TERMINALS 15. CONTACT SWISHER SERVICE REPRESENTATIVE 16. ADD OIL / RECHECK LEVEL CHANGE OIL 17. CLEAN UNDERSIDE OF MOWER
UNIT DOES NOT TRACK STRAIGHT	<ol style="list-style-type: none"> 1. IMPROPER AIR PRESSURE 2. TRACKING ADJUSTMENTS OUT OF ADJUSTMENT 	<ol style="list-style-type: none"> 1. CHECK AND ADJUST TIRE PRESSURE 2. SEE TRACKING ADJUSTMENT IN SERVICE SECTION

SUGGESTED GUIDE FOR SIGHTING SLOPES FOR SAFE OPERATION

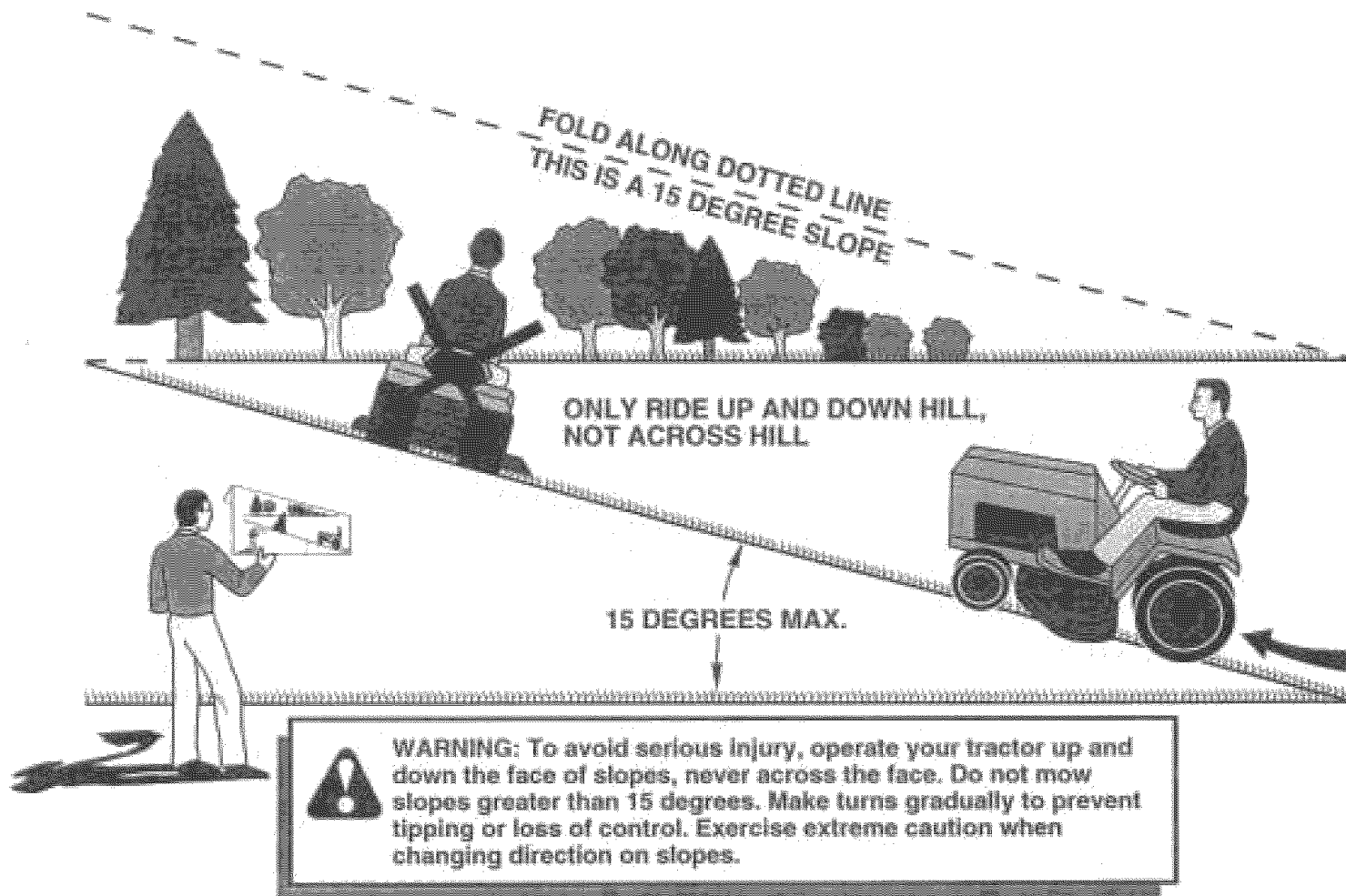

1. Fold this page along dotted line indicated above.
2. Hold page before you so that its left edge is vertically parallel to a tree trunk or other upright structure.
3. Sight across the fold in the direction of hill slope you want to measure.
4. Compare the angle of the fold with the slope of the hill.

WARRANTY RIGHTS AND OBLIGATIONS

YOUR WARRANTY RIGHTS AND OBLIGATIONS: The California Air Resources Board and Swisher Mower, is pleased to explain the evaporative emission control system (EECS) on your model year 2006 and later Swisher Product. In California, new Outdoor Power Equipment, must be designed, built and equipped to meet the State's stringent anti-smog standards. Swisher Mower must warrant the EECS on your Power Equipment, for the period of time listed below provided there has been no abuse, neglect, or improper maintenance. For model year 2006 the EECS on your mower includes the liquid fuel lines, fuel line connectors, and fuel line clamps. Where a warrantable condition exists, Swisher Mower will repair at no cost to you. Expenses covered under warranty include diagnosis, parts, and labor.

MANUFACTURER'S WARRANTY COVERAGE: For a period of two years, any evaporative emission-related part included in the list of EECS parts for your mower is defective, the part will be repaired or replaced by Swisher Mower.

OWNER'S WARRANTY RESPONSIBILITIES: As the owner of this Power Equipment, you are responsible for performance of the required maintenance listed in your owner's manual. Swisher Mower recommends that you retain all receipts covering maintenance on your Power Equipment, but Swisher Mower cannot deny warranty solely for the lack of receipts. As the Power Equipment owner, you should be aware that Swisher Mower, may deny you warranty coverage if your Power Equipment, or a covered part has failed due to abuse, neglect, or improper maintenance, unapproved modifications, or the use of parts not made or approved by the equipment manufacturer. You are responsible for presenting your Power Equipment to an authorized Swisher Service center as soon as the problem exists. Warranty repairs should be completed in a reasonable amount of time, not to exceed 30 days. If you have a question regarding your warranty rights and responsibilities, you should contact the Swisher Mower Service representative at 1-800-222-8183.

WARRANTY COMMENCEMENT DATE: The warranty period begins on the date the Power Equipment is purchased.

LENGTH OF COVERAGE: This warranty shall be for a period of two (2) years from the initial date of purchase.

WHAT IS COVERED: Warranted parts include the Liquid fuel line, fuel line connectors, and fuel line clamps.

REPAIR OR REPLACEMENT OF PARTS: Repair or replacement of any evaporative warranted part will be performed at no charge to the owner at an authorized Swisher Mower Service Center. If you have a question regarding your warranty rights and responsibilities, you should contact your nearest authorized service center or call the Swisher Mower Service representative at 1-800-222-8183.

WARRANTY PERIOD: Any warranted part is not scheduled for replacement as required maintenance, or which is scheduled only for regular inspection to the effect of "repair or replace as necessary" shall be warranted for two (2) years. Any warranted part that is scheduled for replacement as required maintenance shall be warranted for the period of time up to the first scheduled replacement point for that part.

DIAGNOSIS: The owner shall not be charged for diagnostic labor that leads to the determination that a warranted part is defective if the diagnostic work is performed at an authorized Swisher Service Center.

CONSEQUENTIAL DAMAGE: Swisher Mower, may be liable for damages to other engine or equipment components caused by the failure of a warranted part still under warranty.

WHAT IS NOT COVERED: All failures caused by abuse, neglect, or improper maintenance is not covered.

ADD-ON OR MODIFIED PARTS: The use of add-on or modified parts may be grounds for disallowing a warranty claim. Swisher Mower is not liable to cover failures of warranted parts caused by the use of an add-on or modified part.

HOW TO FILE A CLAIM: If you have a question regarding your warranty rights and responsibilities, you should contact your nearest authorized service center or call Swisher Mower Service representative at 1-800-222-8183.

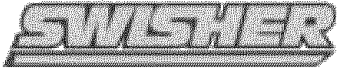

swisherinc.com

OWNER'S MANUAL

MODEL NO.
ZT1436B
ZT18542
ZT2250

"Z" SERIES

ZERO TURN HYDROSTATIC DRIVE

Each mower has its own model number. Each engine has its own model number. The model number for the mower will be found under the seat. The model number for the engine will be found on the top of the blower fan housing.

All mower parts listed herein may be ordered directly from Swisher Mower & Machine Co. Inc. or your nearest Swisher dealer.

All engine parts may be ordered from the nearest dealer of the engine supplied with your mower.

WHEN ORDERING PARTS, PLEASE HAVE THE FOLLOWING INFORMATION AVAILABLE:

- * PRODUCT - Zero Turn Rider ("Z" Series)
- * SERIAL NUMBER - _____
- * MODEL NUMBER - _____
- * ENGINE MODEL NUMBER - _____
- TYPE - _____
- * PART NUMBER WITH PAINT CODE
- * PART DESCRIPTION

TELEPHONE - 1-800-222-8183

FAX - 1-660-747-8650

SWISHER MOWER & MACHINE CO. INC.

1602 CORPORATE DRIVE

P.O. BOX 67

WARRENSBURG, MO 64093

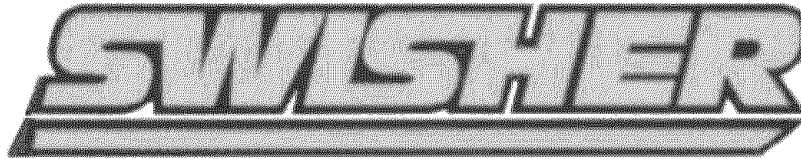

SWISHER MOWER & MACHINE CO. INC.